

ARIES-CS Power Core Engineering

Presented by A. R. Raffray

Contributors:

Power Core Design & Integration:	S. Malang, X. R. Wang (UCSD)
Nuclear Analysis:	L. El-Guebaly (UW), P. Wilson (UW), D. Henderson (UW)
Coil Material and Design:	L. Bromberg (MIT)
Coil Structural Design and Analysis:	X. R. Wang (UCSD)
Divertor Design and Analysis:	T. Ihli (FZK), S. Abdel-Khalik (G. Tech)
Assembly and Maintenance:	S. Malang, X. R. Wang (UCSD), L. Waganer (Boeing), R. Peipert Jr (Boeing)
Safety and Environmental Analysis:	B. Merrill (INL), L. El-Guebaly (UW), C. Martin (UW)

and the ARIES-CS Team

ARIES-CS Review Meeting
October 5, 2006
PPPL, Princeton, NJ

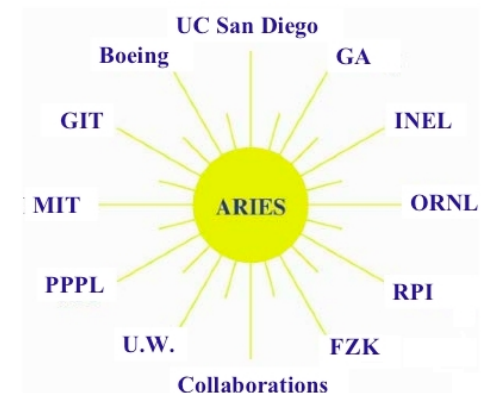

Outline

- **Design challenges associated with a CS**
- **Engineering effort to address these challenges**
 - **Neutron wall load and heat flux**
 - **Radial build**
 - **Blanket**
 - **Integration and Maintenance**
 - **Coil design and structural analysis**
 - **Divertor**
 - **Alpha loss**
 - **Safety and environmental analysis**
 - **Advanced fabrication method for coil structure**
- **Summary**



The ARIES Team is Completing the Last Phase of the ARIES-CS Study

Phase I: Development of Plasma/coil Configuration Optimization Tool

1. Develop physics requirements and modules (power balance, stability, β confinement, divertor, *etc.*)
2. Develop engineering requirements and constraints through scoping studies.
3. Explore attractive coil topologies.



Phase II: Exploration of Configuration Design Space

1. Physics: β , aspect ratio, number of periods, rotational transform, shear, *etc.*
2. Engineering: configuration optimization through more detailed studies of selected concepts
3. Trade-off studies (systems code)
4. Choose one configuration for detailed design.

Phase III: Detailed system design and optimization

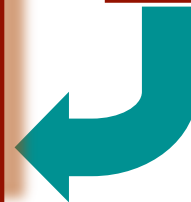

Key Stellarator Constraints Impacting the Engineering Design and Performance of the Power Plant

- **Minimum distance between coil and plasma**
 - **Neutron wall load peaking factor**
 - **Space available for maintenance under complex coil configurations**
 - **Alpha loss**
-
- **Our goal was to push the design to its constraint limits to help assess the attractiveness of a CS power plant and understand key R&D issues driving these constraints**
 - **Understanding that some parameters would have to be relaxed to increase margin**



We Considered Different Configurations Including NCSX-Like 3-Field Period and MHH2-Field Period Configurations

NCSX-Like 3-Field Period

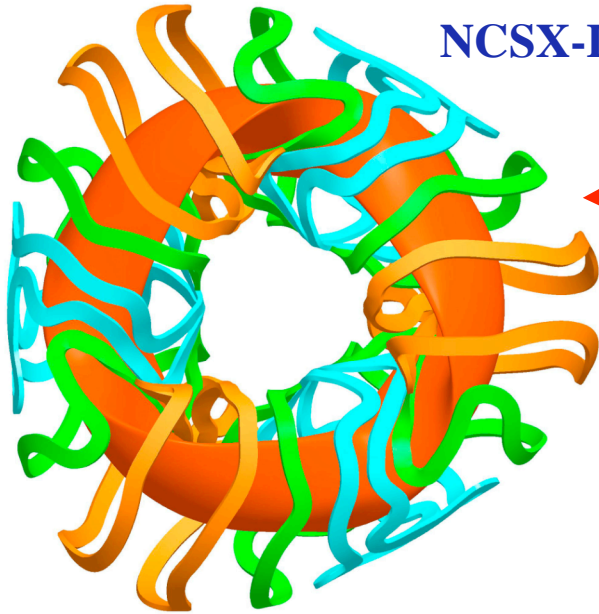

Parameters for NCSX-Like 3-Field Period

Min. coil-plasma distance (m)	1.3
Major radius (m)	7.75
Minor radius (m)	1.7
Aspect ratio	4.5
\square (%)	5.0
Number of coils	18
B_o (T)	5.7
B_{max} (T)	15.1
Fusion power (GW)	2.4
Avg./max. wall load (MW/m ²)	2.6/5.3
Avg./max. plasma q'' (MW/m ²)	0.58/0.76
Alpha loss (%)	5
TBR	1.1

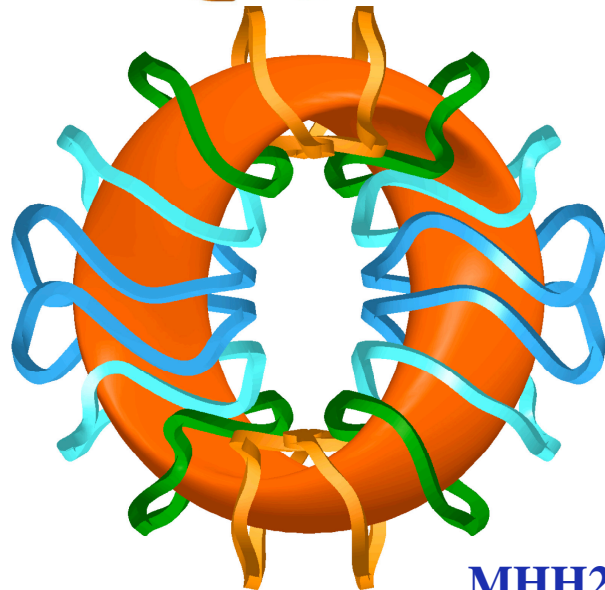

MHH2 2-Field Period

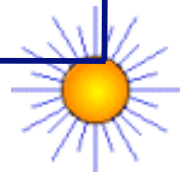

Neutron wall load distribution and heat flux distribution



CAD/MCNP Coupling Approach Developed to Model ARIES-CS for Nuclear Assessment

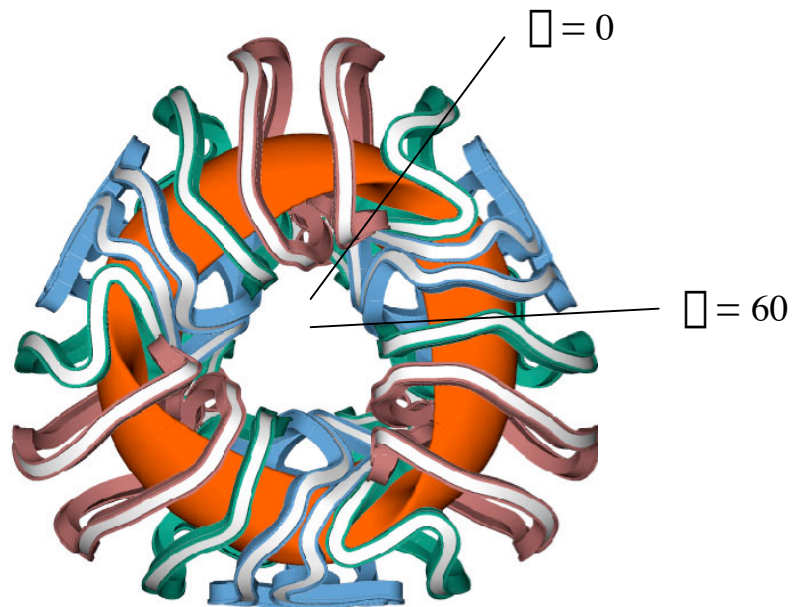

**3-D FW Model
for NWL and
Heat Flux
Distribution**

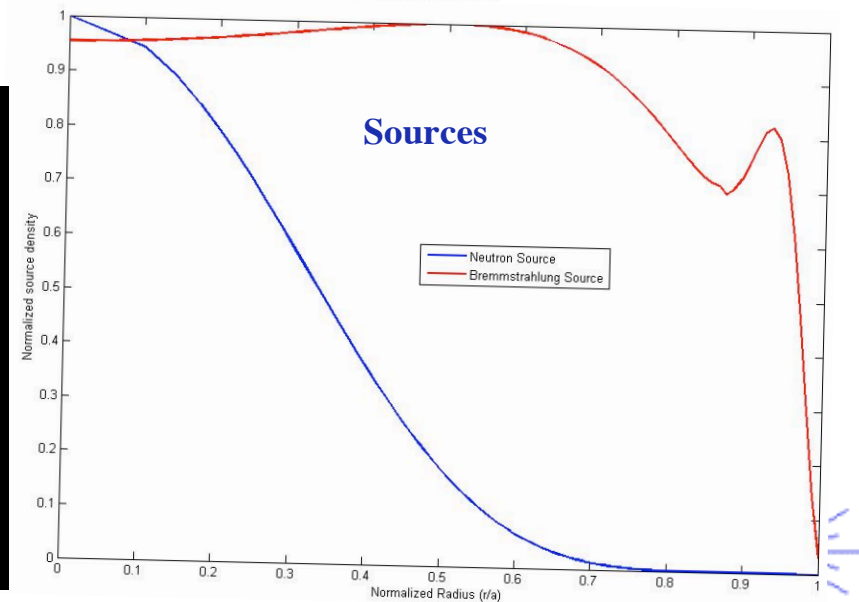
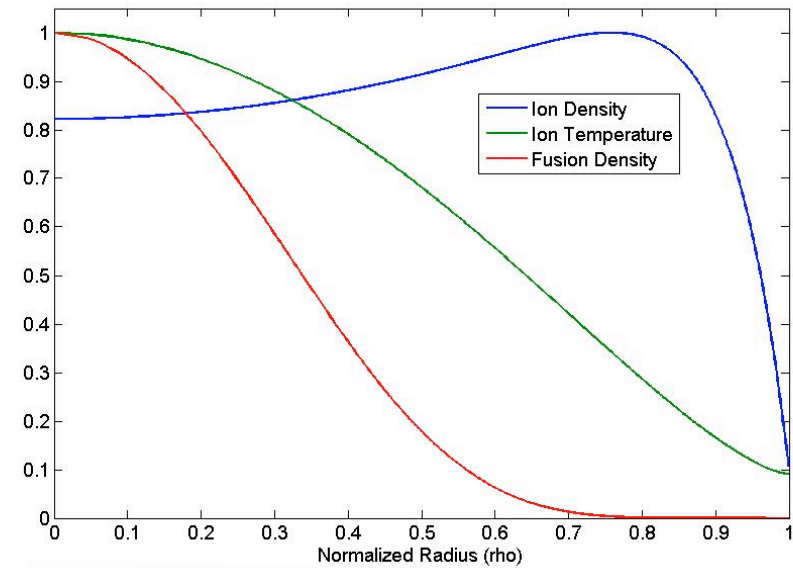
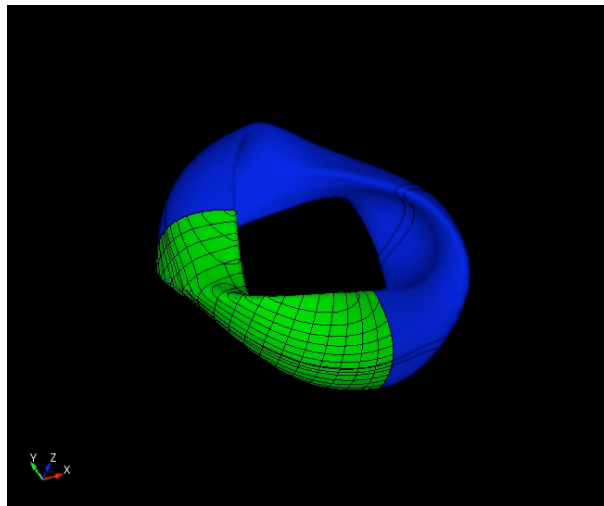

Neutron Wall Load and Plasma Heat Flux Distribution

Neutron Wall Load:

Max/Min = 5.3/0.32 MW/m²

Avg. = 2.6 MW/m²

Neutron wall load

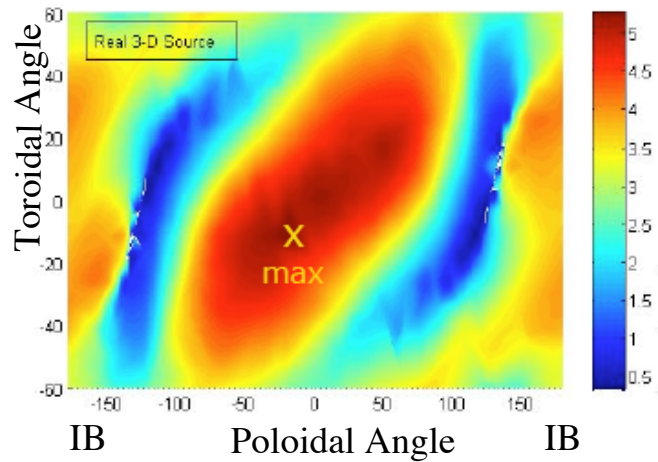

Plasma Heat Flux to FW:

Core radiation:

Max/Min = 0.68/0.2 MW/m²

Avg. = 0.48 MW/m²

Total:

Max/Min = 0.76/0.28 MW/m²

Avg. = 0.57 MW/m²

Radiation heat flux

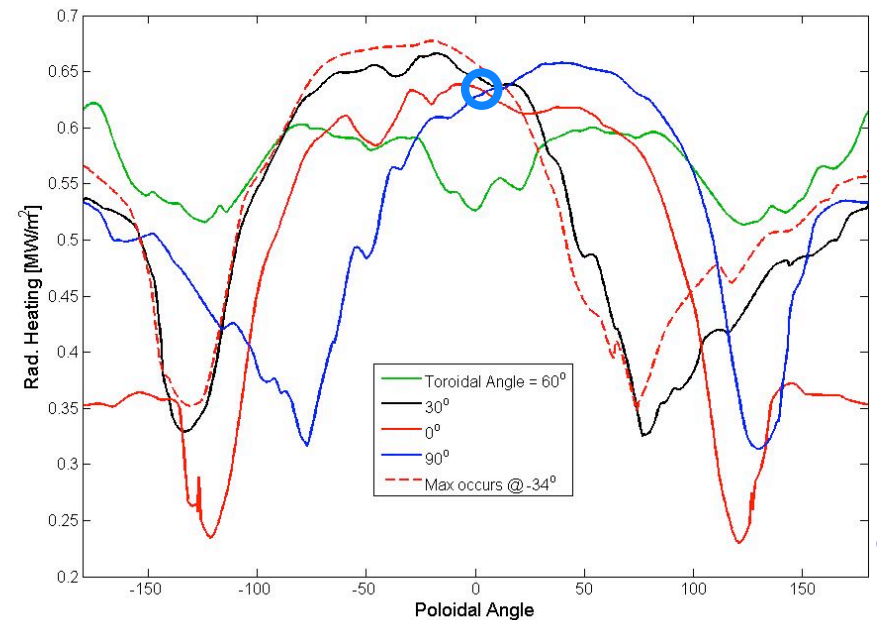
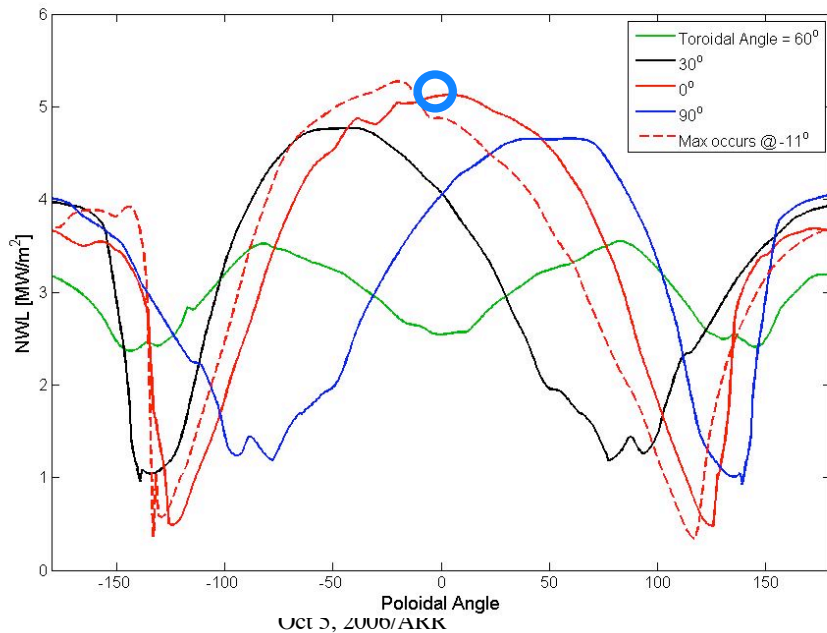
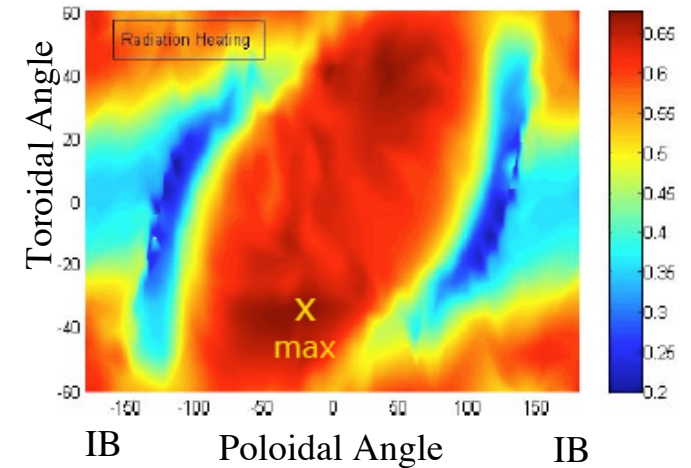

Radial build

(to provide required breeding and shielding)



Optimized Blanket & Shield Provide Adequate Breeding and Protect Vital Components

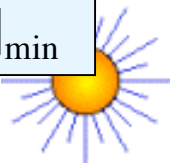
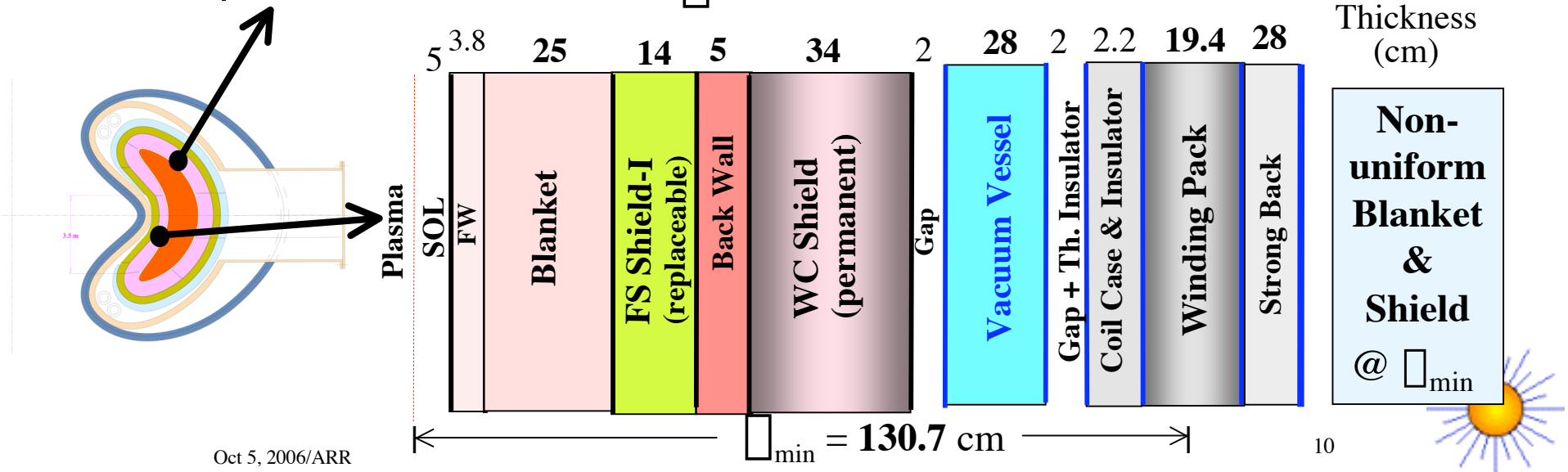
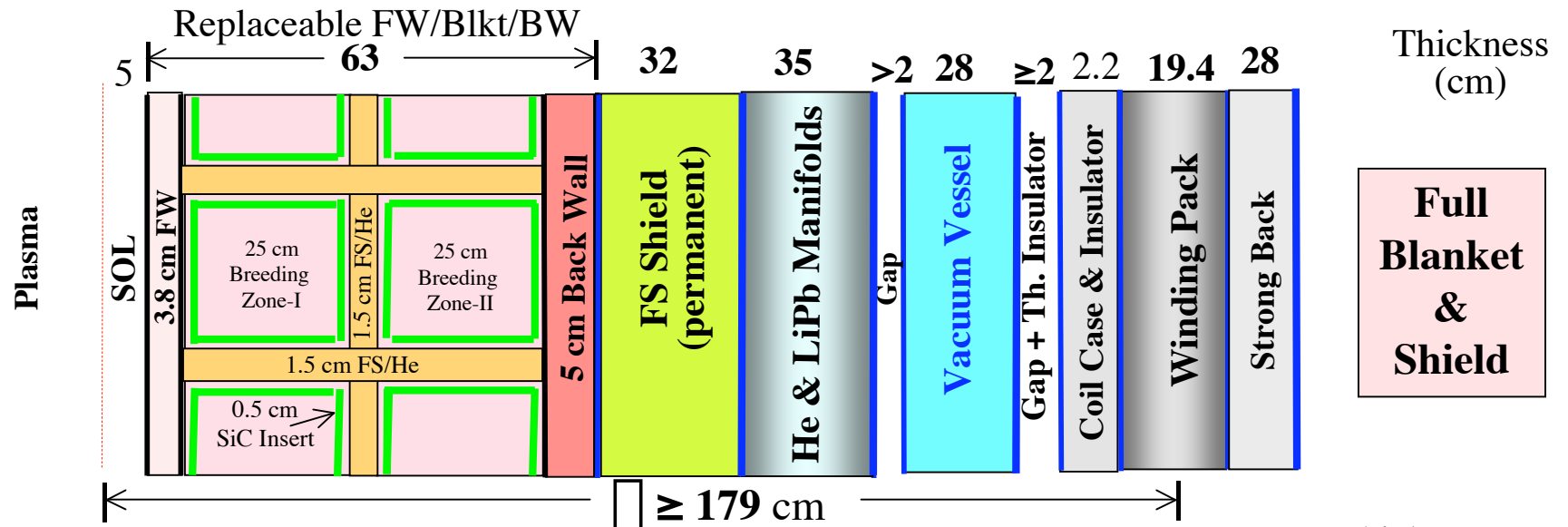

Novel Blanket/Shielding Approach Helps Achieve Compactness, Minimizing Plasma-Coil Standoff

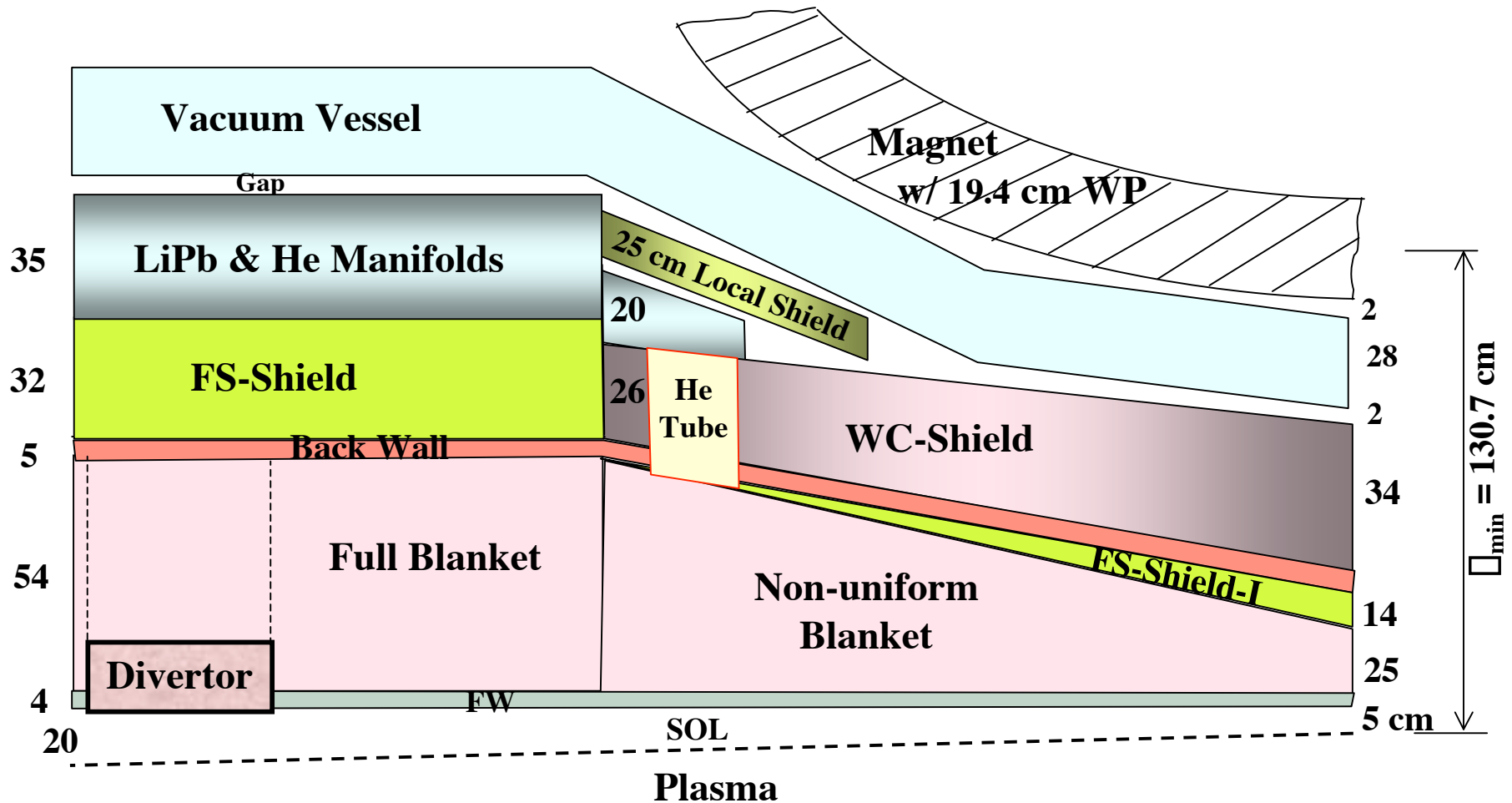

Full Blanket/shield **and** Divertor
(61%+15%= 76% of FW area)

Non-uniform, Tapered Blanket/Shield
(24% of FW area)



Radial Build Satisfies Design Requirements

Overall TBR:

(for T self-sufficiency)

1.1 *

Damage to Structure:

(for structural integrity)

200 dpa - RAFS
3% burnup - SiC

Helium Production @ Manifolds and VV:

(for reweldability of FS)

1 He appm

S/C Magnet (@ 4 K):

- Peak fast n fluence to Nb₃Sn ($E_n > 0.1$ MeV):
- Peak nuclear heating:
- Peak dpa to Cu stabilizer:
- Peak dose to electric insulator:

10¹⁹ n/cm²
2 mW/cm³
6x10⁻³ dpa
> 10¹¹ rads

Plant Lifetime:

40 FPY

Availability:

~ 85%

Additional nuclear parameters:

- *Overall energy multiplication:*
- *FW/blanket lifetime:*

1.16*
3 FPY



Space Restriction Quite Challenging for Providing Required Shielding, In Particular Around Penetrations and He Coolant Piping

- Neutron streaming through penetrations compromises shielding performance.
- ARIES-CS penetrations:
 - 198 He tubes for blanket (30 cm ID)
 - 24 Divertor He access pipes (~30 cm ID)
 - 30 Divertor pumping ducts (42 x 120 cm each)
 - 12 Large pumping ducts (1 x 1.25 m each)
 - 3 ECH ducts (24 x 54 cm each).
 - 6 main He pipes - HX to & from blanket (72 cm ID each)
 - 6 main He pipes - HX to & from divertor (70 cm ID each)
- Solutions:
 - Local shield behind penetrations
 - He tube axis oriented toward lower neutron source
 - Penetration shield surrounding ducts
 - Replaceable shield close to penetrations
 - Rewelding of VV and manifolds avoided close to penetrations
 - Bends included in some penetrations.

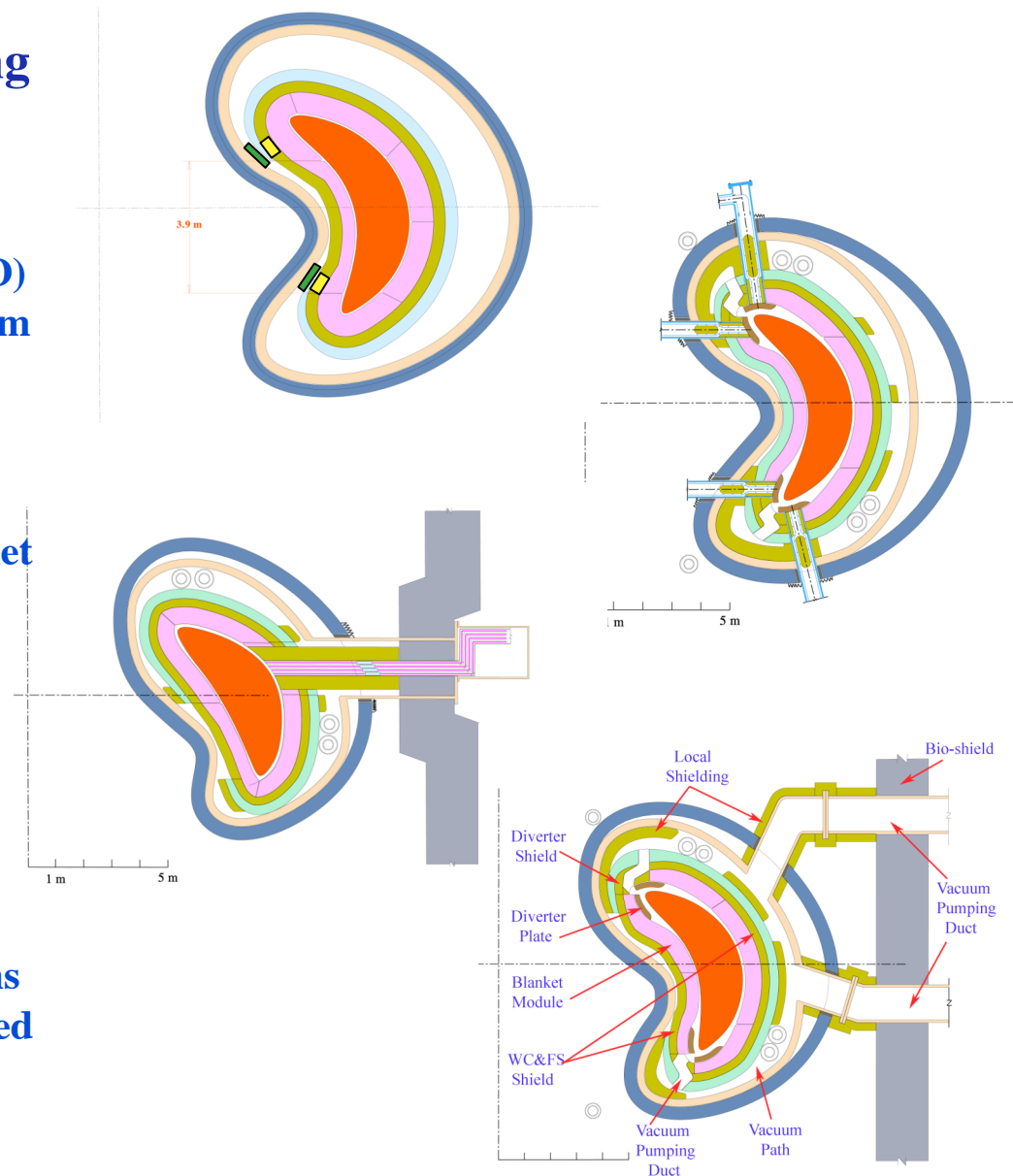

Blanket



Selection Based on Scoping Studies of a Number of Blanket Concepts

- 1. Dual Coolant concept with a self-cooled Pb-17Li zone and He-cooled RAFS structure.**
 - He cooling needed for ARIES-CS divertor
 - Additional use of this coolant for the FW/structure of blankets facilitates pre-heating of blankets, serves as guard heating, and provides independent and redundant afterheat removal.
 - Generally good combination of design simplicity and performance.
 - Build on previous effort, further evolve and optimize for ARIES-CS configuration
 - Originally developed for ARIES-ST
 - Further developed by EU (FZK)
 - Now also considered as US ITER test module
- 2. Self-cooled Pb-17Li blanket with SiC_f/SiC composite as structural material.**
 - More compact design (no He), higher efficiency, more attractive safety features (LSA=1), and lower COE.
 - Desire to maintain this higher pay-off, higher development risk option as alternate to assess the potential of a CS with an advanced blanket

Dual Coolant Blanket Module Redesigned for Simpler More Effective Coolant Routing

- 10 MPa He to cool FW toroidally and box
- Slow flowing (<10 cm/s) Pb-17Li in inner channels
- RAFS everywhere ($T_{max} < 550^{\circ}C$)
- Additional layer of ODS-FS on FW ($T_{max} < 700^{\circ}C$)

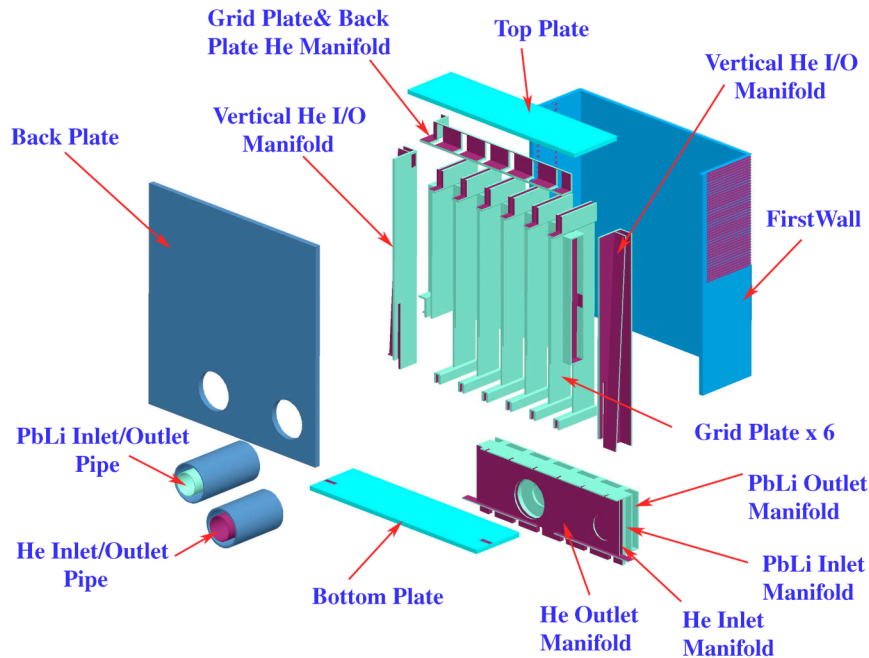
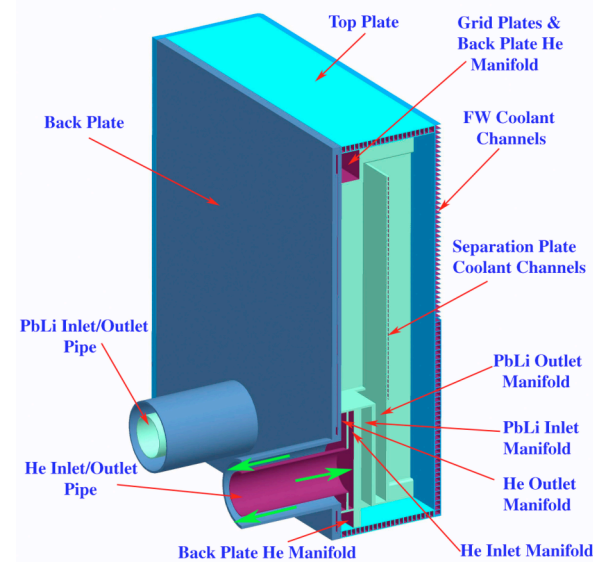
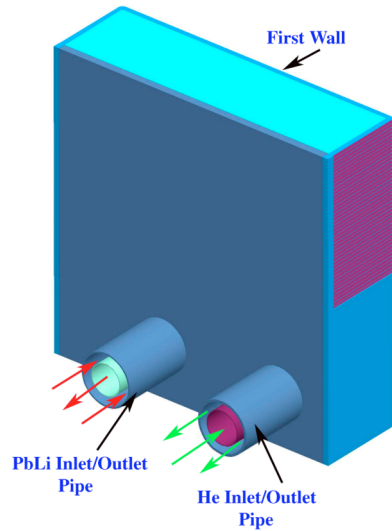

- SiC insulator lining Pb-17 Li channel for thermal and electrical insulation to maximize $T_{Pb-17Li}$ and minimize MHD ΔP while accommodating compatibility limit $T_{FS/Pb-17Li} < 500^{\circ}C$

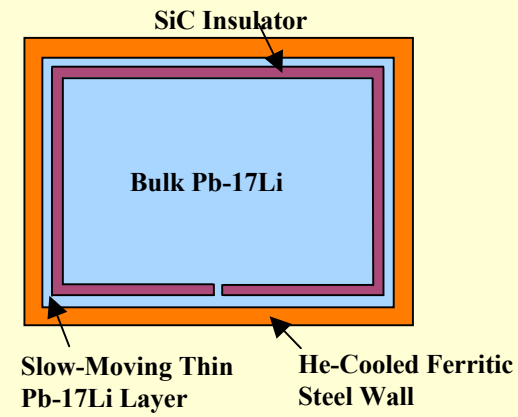

Coolant Routing Through HX Coupling Blanket and Divertor to Brayton Cycle

- Div He T_{out} ~ Blkt Pb-17Li T_{out}
- Min. $\Delta T_{HX} = 30^\circ\text{C}$
- $P_{Friction} \sim \rho_{pump} \times P_{pump}$

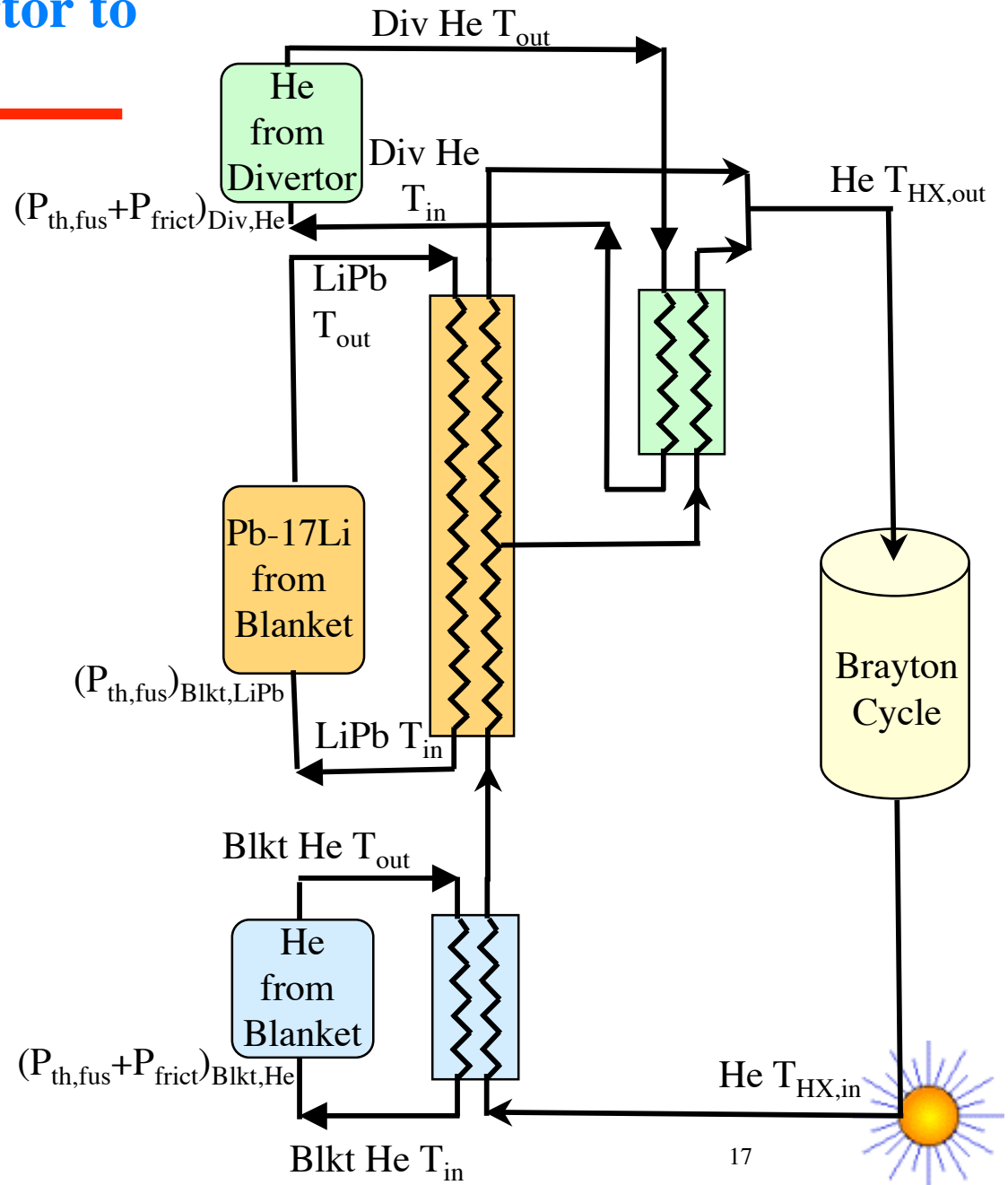
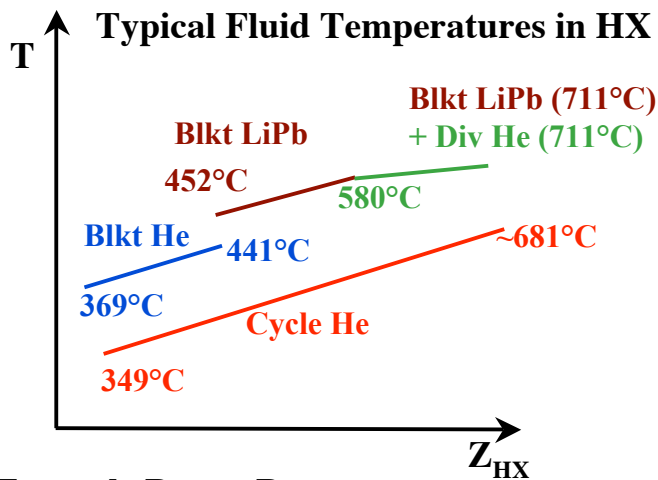

Example Power Parameters

Fusion Thermal Power in Reactor Core	2650 MW
Fusion Thermal Power in Pb-17Li	1420 MW
Fusion Thermal Power in Blkt He	1030 MW
Friction Thermal Power in Blkt He	119 MW
Fusion Thermal Power in Div He	201 MW
Friction Thermal Power in Div He	29 MW
Total Fusion + Friction Thermal Power	2790 MW
Brayton cycle efficiency	0.42

Optimization of DC Blanket Coupled to Brayton Cycle Assuming a FS/Pb-17Li Compatibility Limit of 500°C and ODS FS for FW

- RA FS $T_{\max} < 550^{\circ}\text{C}$; ODS $T_{\max} < 700^{\circ}\text{C}$
- The optimization was done by considering the net efficiency of the Brayton cycle for an example 1000 MWe case.
 - 3-stage compression + 2 inter-coolers and a single stage expansion
 - $\eta_{\text{Turbine}} = 0.93$; $\eta_{\text{Compressor}} = 0.89$; $\eta_{\text{Recuperator}} = 0.95$; Total comp. ratio < 3.5

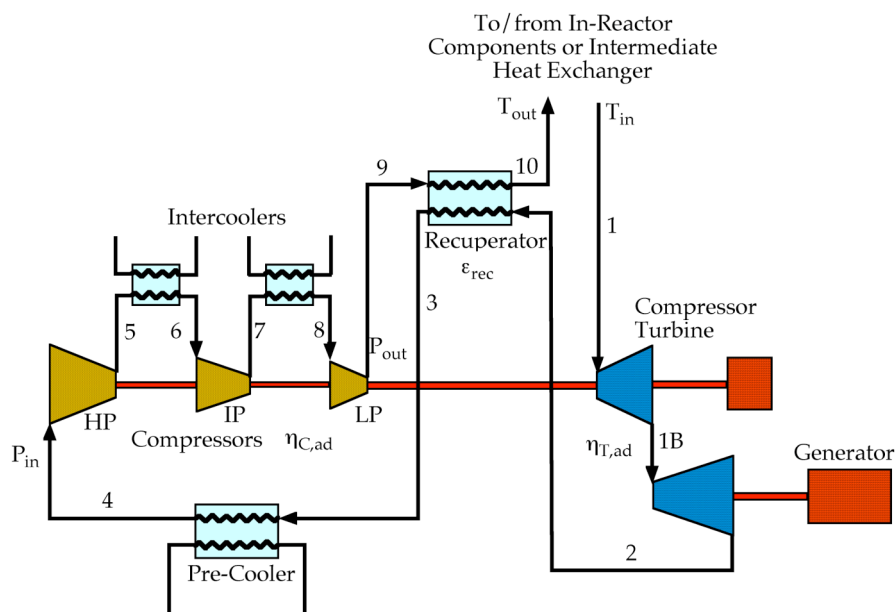

Efficiency v. neutron wall load

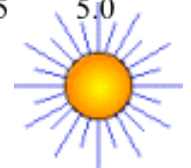
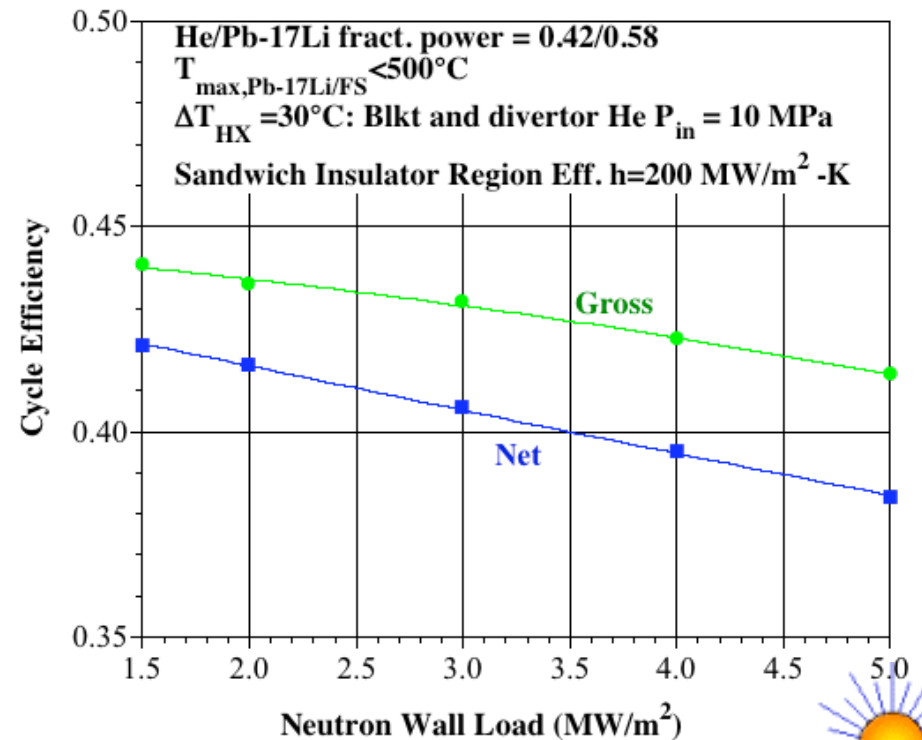

Challenging to Design Blanket FW/Module Within Stress Limits for High Heat Flux and Neutron Wall Load Location

Alloy	T (°C)	S _m (MPa)	3 S _m (MPa)
F-82H	500	133	399
	550	118	354
	600	101	303
ODS LAF-3	500	268	804
	650	133	399
	700	111	333
ODS 12YWT	500	≤500	≤1500
	550	≤460	≤1380
	600	≤420	≤1260
	650	≤220	≤660
	700	≤210	≤630
	750	≤170	≤510
	800	≤155	≤465

q'' (MW/m ²)	0.5	0.76	0.76	0.76	0.76
NWL (MW/m ²)	2.6	2.6	2.6	2.6	5.2
Ref. T (°C)	369	369	369	432	369
He P (MPa)	10	10	0	10	10
Max. temp. of ODS-FS (°C)					~644
Max. stress in ODS-FS (MPa) (Plane strain)	487	635	590	533	667
Max. stress in ODS-FS (MPa) (Plane stress)	449	458	307	458	
Max. temp. of RAFS (°C)					~560
Max. stress in RAFS (MPa) (Plane strain)		~350			~390

• Design for:
 $\sigma_{\text{secondary}} + \sigma_{\text{primary}} < 3 S_m$

• Use 3-mm layer of ODS FS on 1-mm RAFS layer for FW design to help maximize operating temperature and cycle efficiency.

• Max. NWL and q'' can be reduced by moving wall back if needed.

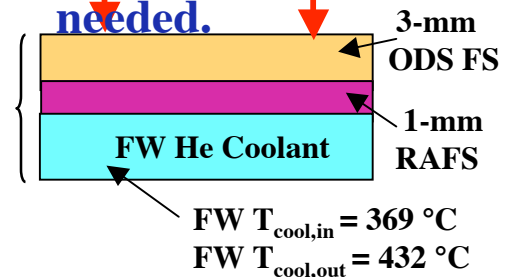
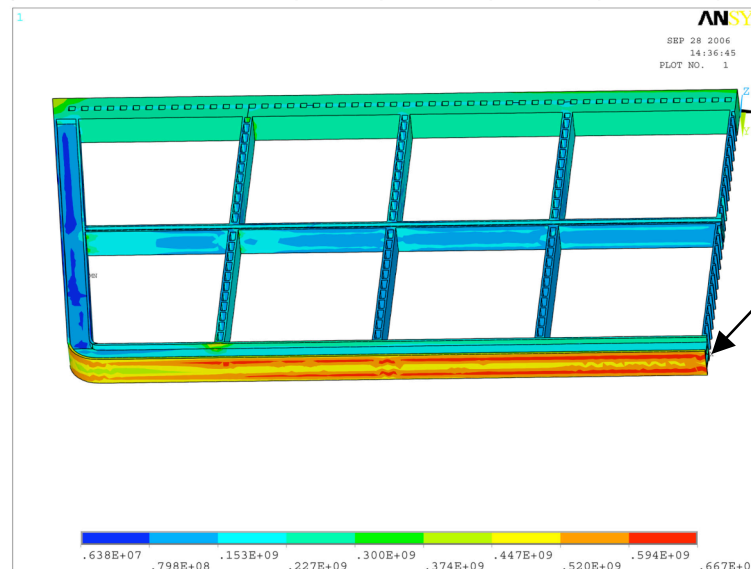

Stress and Temperature Profiles for Example Case

- Neutron wall load = 5.3 MW/m^2
- Plasma heat flux = 0.76 MW/m^2

- Reference temperature = 369°C (=He T_{in})
- Plane strain assumptions

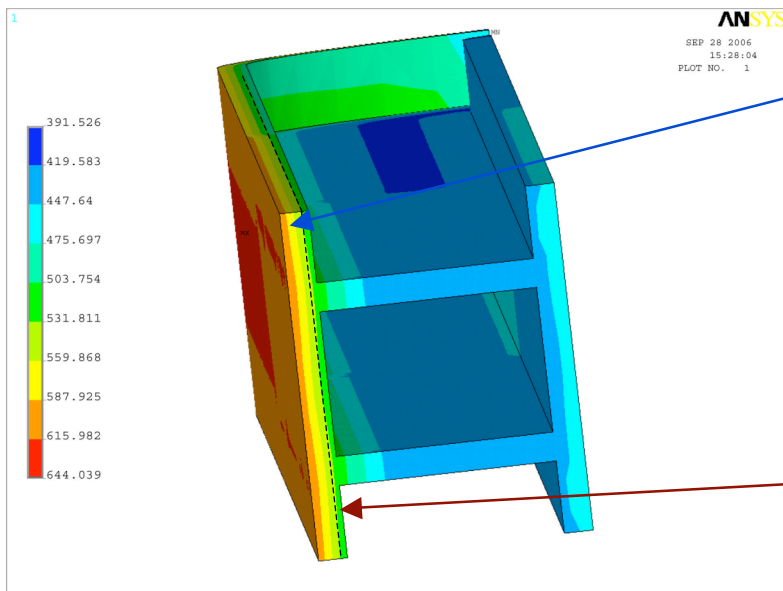
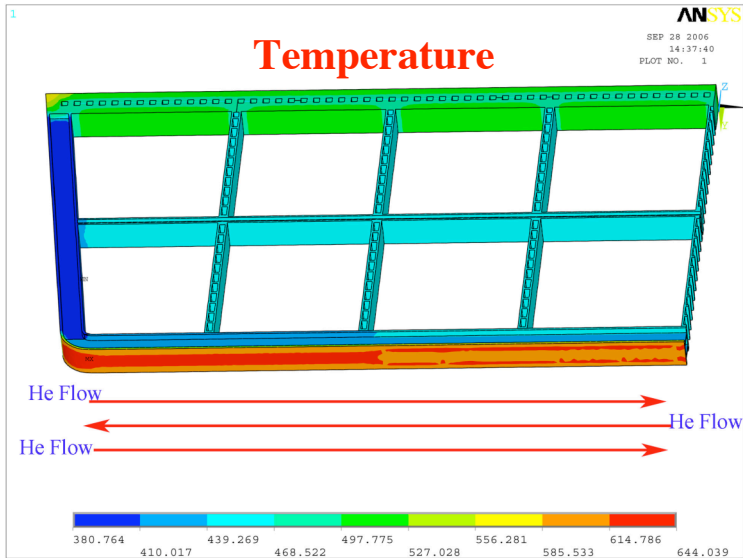

ODS FS

RAFS

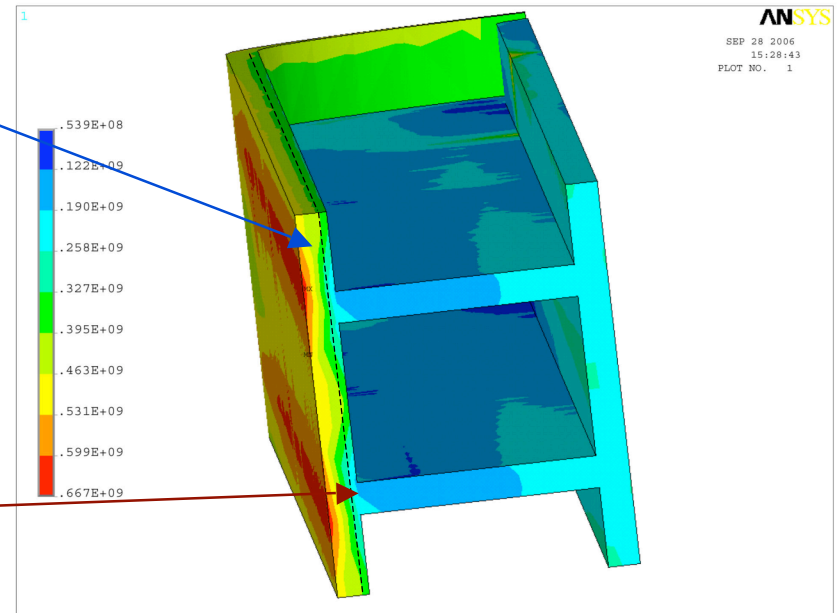

Maintenance Scheme and Integration



Port-Based Maintenance Chosen

(suited for both 2-field and 3-field period configurations)

- **Two dedicated ports per field period**
 - 4 m high by 1.8 m wide at 0° and ~2 m² at 35° (also used for ECH)
 - Modular design of blanket (~2 m x ~2m x ~0.63 m) and divertor plates (~3 m x ~1m x ~0.2 m) compatible with maintenance scheme.
- **Vacuum Vessel Internal to the Coils**
 - For blanket maintenance, no disassembling and re-welding of VV required and modular coils kept at cryogenic temperatures.
 - Closing plug used in access port.
 - Articulated booms utilized to remove and replace 198 blanket modules and 24 divertor modules (max. combined weight ~5000 kg).

Top view of 3 field-period configuration showing location of ports

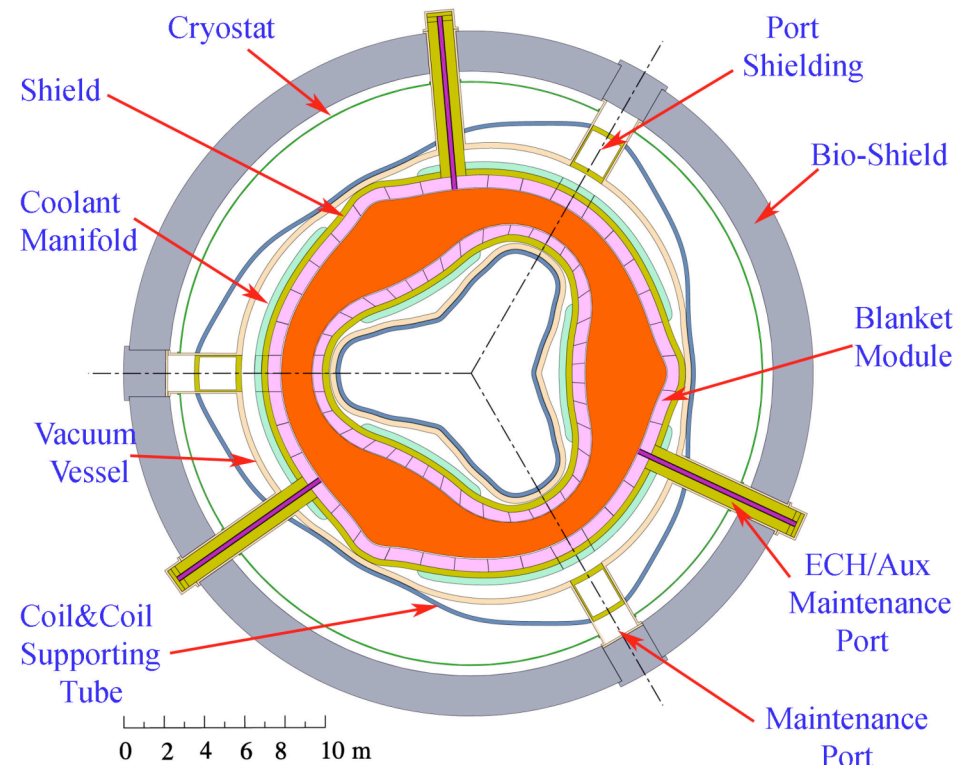

A Key Aim of the Design is to Minimize Thermal Stresses

- Hot core (including shield and manifold) ($\sim 450^{\circ}\text{C}$) as part of strong skeleton ring (continuous poloidally, divided toroidally in sectors) separated from cooler vacuum vessel ($\sim 200^{\circ}\text{C}$) to minimize thermal stresses.
- Concentric coolant access pipes for both He and Pb-17Li, with return He in annulus (at $\sim 450^{\circ}\text{C}$) and inlet Pb-17Li in annulus (at $\sim 450^{\circ}\text{C}$) to maintain near uniform temperature in skeleton ring.
- Each skeleton ring sector rests on sliding bearings at the bottom of the VV and can freely expand relative to the VV.
- Blanket modules are mechanically attached to this ring and can float with it relatively to the VV.
- Bellows are used between VV and the coolant access pipes at the penetrations. These bellows provide a seal between the VV and cryostat atmospheres, and only see minimal pressure difference.
- Temperature variations in blanket module minimized by cooling the steel structure with He (with $\Delta T < 100^{\circ}\text{C}$).

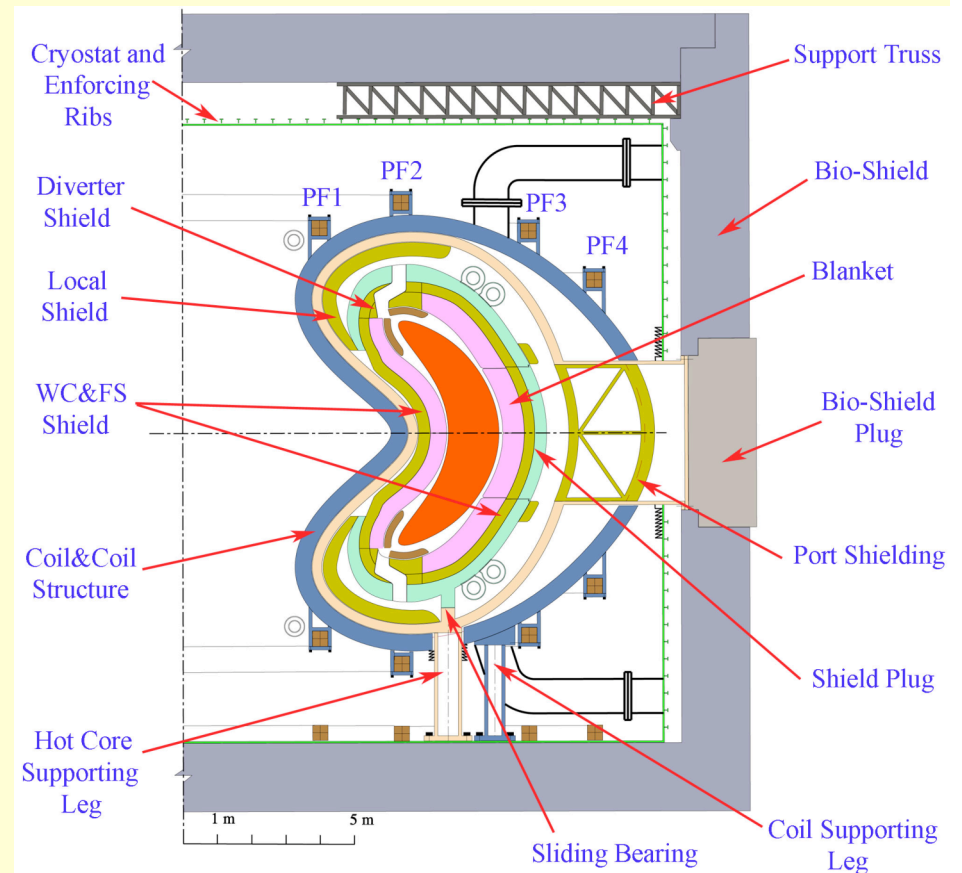

Blanket Module Replacement for Port-Based Maintenance Assumes Prior Removal of Adjacent Module and Access from Plasma Side

- Pipe cutting/rewelding from outside preferred for conventional scheme.
- Use of equipment similar to what is already commercially-available.
- Shield pieces first removed to access coolant piping.
- First cut then performed and shielding ring (protecting rewelding area from neutron streaming) removed from inside piping
- Final coolant piping cut performed at the back of the shield where He production is small enough to allow re-welding ($< \sim 1$ appm He).

Example of Pipe Cutting/Rewelding For He Supply to Blanket Modules Following Removal of Port Module

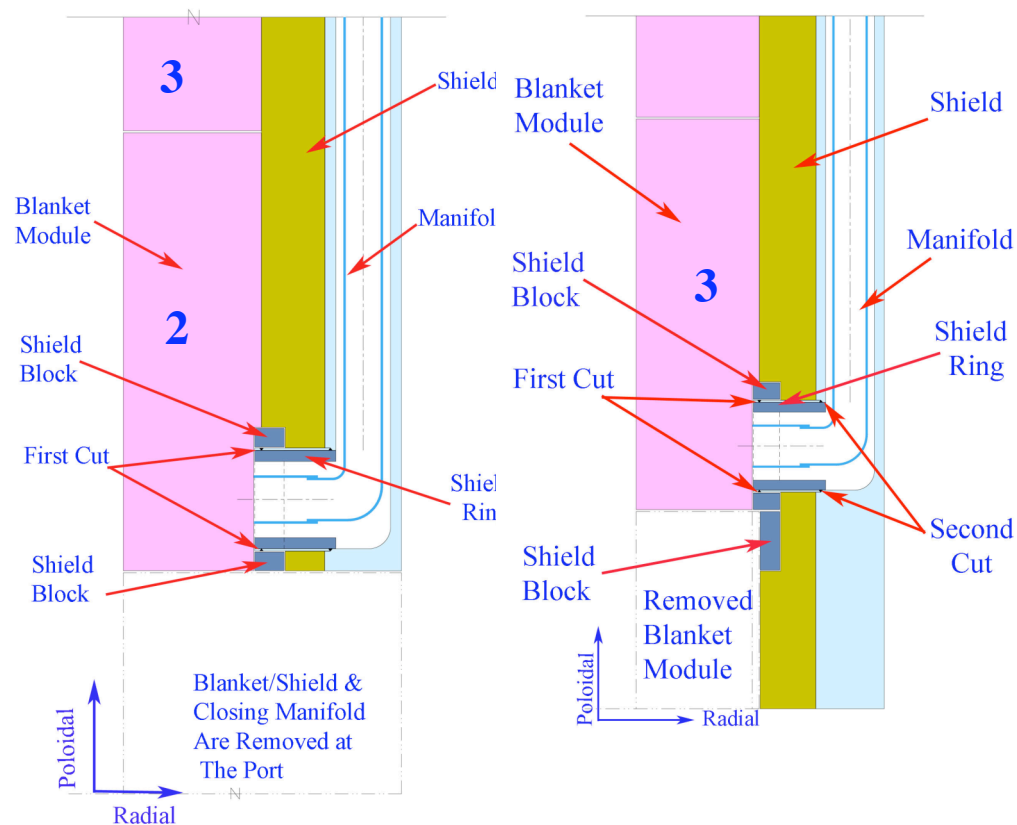

Port Maintenance Design Approach

- **Replace all FW/blanket and divertor modules, and ECH launchers every 3 FPY. Remainder is life-of-plant.**
 - **Blanket and divertor modules removable inside core**
 - **ECH launcher designed as a removable assembly**
- **All power core maintenance fully robotic and automated based on prototypes and production plants**
- **Work simultaneously on all three field periods**
- **Employ maintenance machines inside fixed port transfer chambers just outside bio-shield**
- **Pass all used and new modules via airlocks to mobile transporters**
- **If conventional tube welding is used, auxiliary maintenance machines ports are needed. More advanced scheme with remote disconnects would cut maintenance time by a factor of 4.**



Mid-Plane View Shows Maintenance At Main and ECH/Aux Maintenance Ports

- Simultaneous maintenance in 3 FP
- Fixed transfer chambers control contamination and enhance times
- Mobile transporters transfer used and new components to/from Hot Cell
- Main port is used for removing blanket and divertor modules
- ECH launcher/waveguide removed as an assembly
- ECH port can then be used as auxiliary maintenance port
- Manipulators inside bioshield at center of power core remove divertor inner tubes and shielding and cut outer divertor tube/support

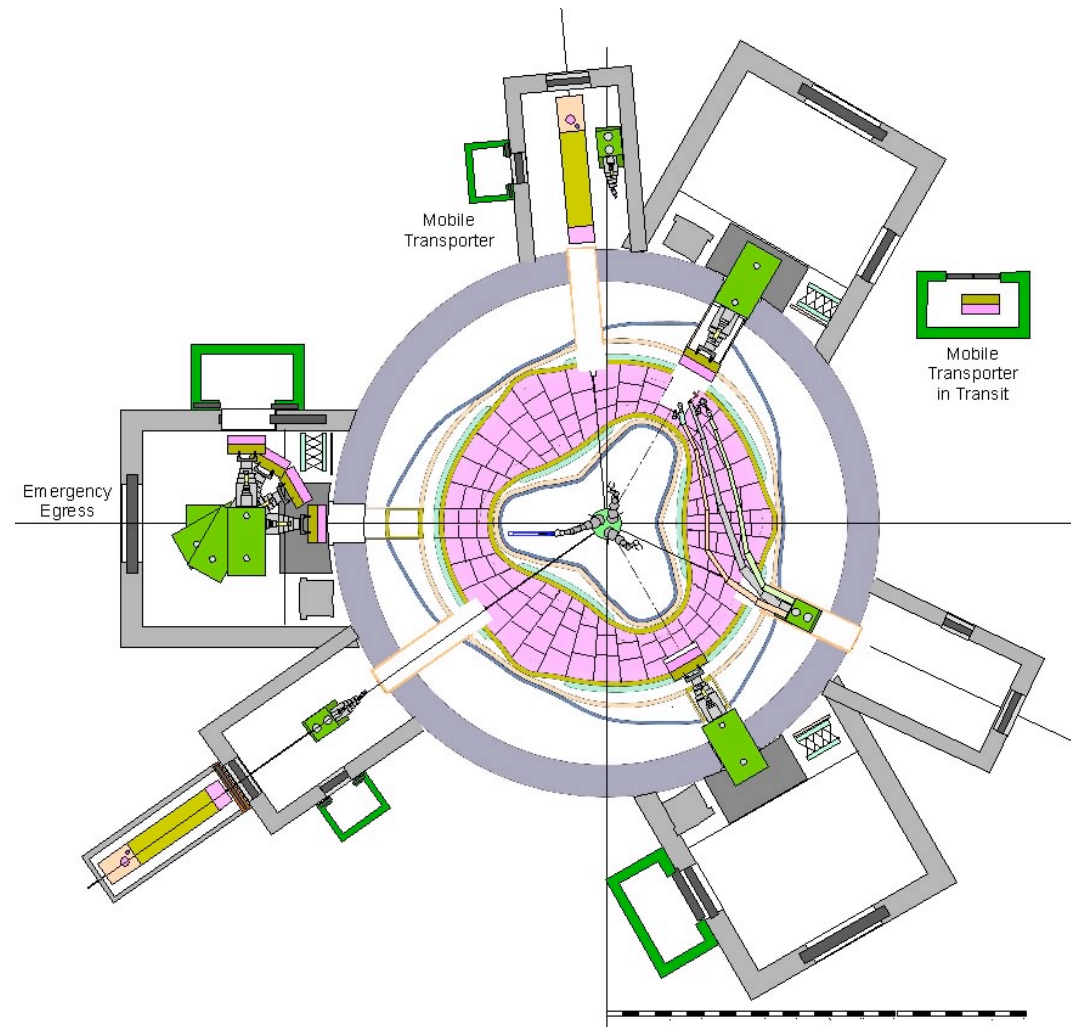

Removable ECH Assembly/ Auxiliary Maintenance Port

- 8 MW of ECH power provided per module (24 MW in all)
- ECH module is removable and includes waveguide, all shielding, bioshield, mirror, and exo-bioshield vacuum vessel
- Entire module assembly can be withdrawn into transfer chamber

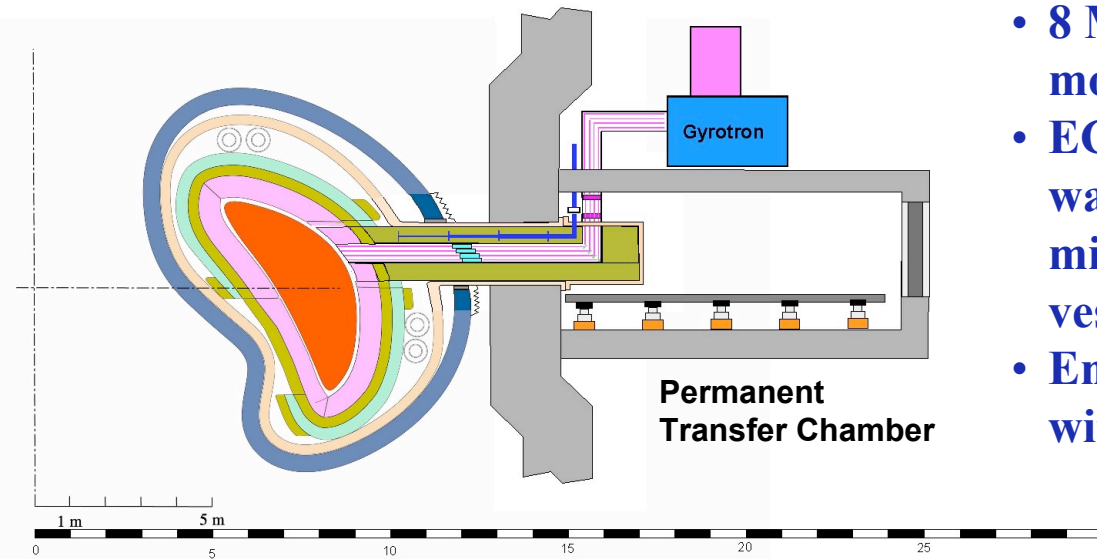

ECH Module Moved Into Mobile Transporter for Transit to Hot Cell for Refurbishment

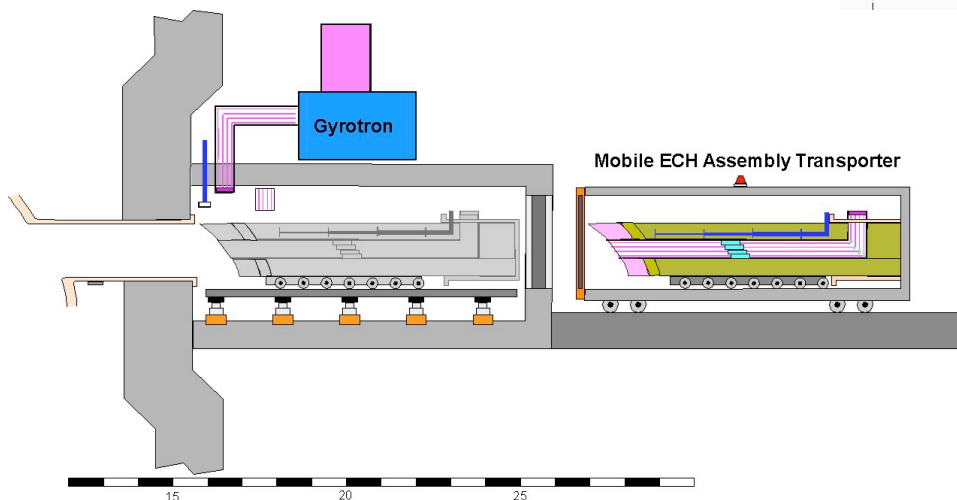

Aux. Manipulator removes blanket shielding blocks, shielding rings, and cuts coolant tubes while main port arm supports and removes blankets

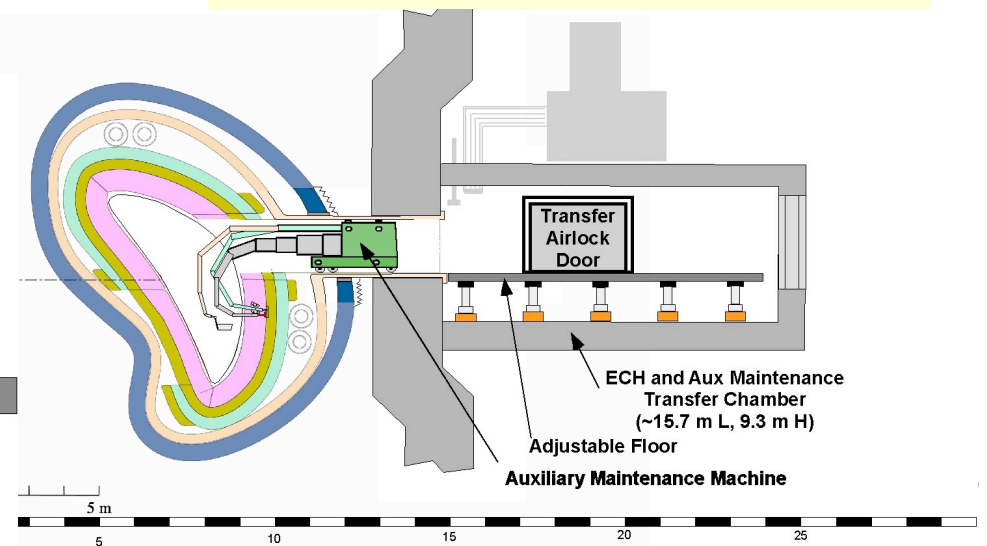

Preparation for Divertor Plate Removal

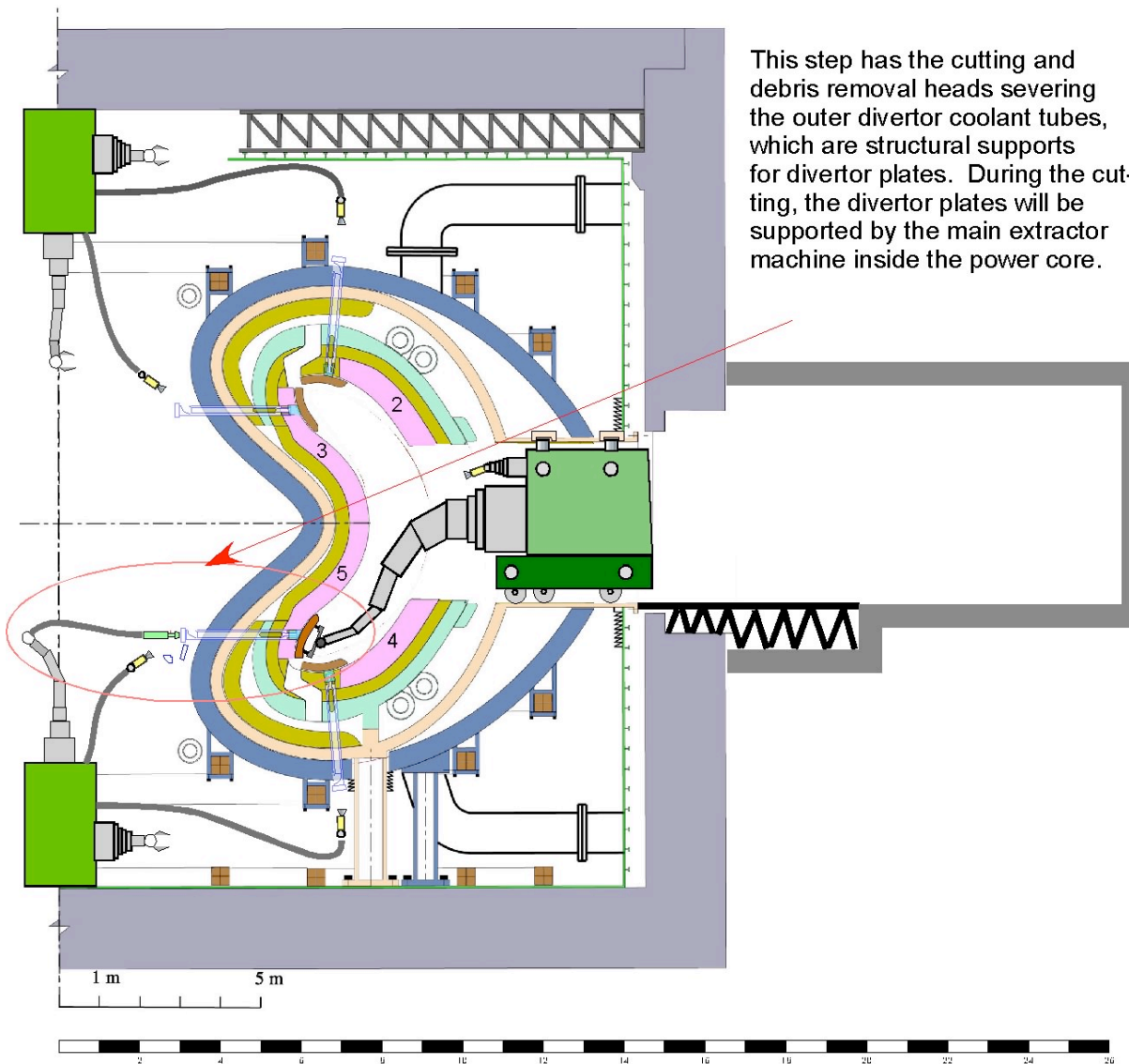

- This depicts the main port extractor holding the divertor plates (24 pl) while the cutting bore tool on the central manipulator severs the outer coolant tube, which is the divertor structural support
- The divertor plates span two blanket modules but they fit through the main port opening



Maintenance and Availability Analysis

ARIES MAINTENANCE TASKS												
Removal Tasks							Replacement Tasks					
Main Port	Shutdown	Port Opening	Divertor Plates	Shielding Blocks & Blanket Modules	Shielding Rings & Coolant Tubes	Shield & Support System Insp.	Shielding Rings & Coolant Tubes	Shielding Blocks & Blanket Modules	Divertor Plates	Chamber Inspection	Port Installation	Start-Up
Task	Shutdown & Prep for Maint.	Open Three Main Maint. Ports	Twenty-four Divertor Plates (8 x 3 Sectors)	Blanket Modules (65 x 3 Sectors)	Shielding Rings & Inner Coolant Tube (65 x 2 x 3 Sectors)	Inspect, Clean & Vacuum - Inspect Repairs	Shielding Rings & Inner Coolant Tube (65 x 2 x 3 Sectors)	Blanket Modules (65 x 3 Sectors)	Twenty-four Divertor Plates (8 x 3 Sectors)	Inspect Chamber After Build-Up	Close Three Main Maint. Ports	Inspect, Diagnostics & Prep for Operation
Time (Hrs)	30.00	10.20	20.40	240.50	139.75	26.00	230.75	429.00	26.40	2.00	13.40	38.00
ECH/Aux Port	Shutdown	ECH Assembly		Shielding Blocks & Blanket Modules	Shielding Rings & Coolant Tubes	Shield & Support System Insp.	Shielding Rings & Coolant Tubes	Shielding Blocks & Blanket Modules		Chamber Inspection	ECH Installation	Start-Up
Task	Shutdown & Prep for Maint.	Remove Three ECH Assemblies		Shielding Blocks & Cut Weld (65x 6 x 3 Sectors)	Shielding Rings & Inner Coolant Tube (65 x 2 x 3 Sectors)	Make Any Needed Repairs	Shielding Rings & Inner Coolant Tube (65 x 2 x 3 Sectors)	Shielding Blocks & Welds (65x 6 x 3 Sectors)		Inspect Chamber After Build-Up	Install Three ECH Assemblies	
Time (Hrs)	30.00	8.40		240.50	139.75	24.00	230.75	429.00		2.00	9.60	38.00
BIO-Chamber	Shutdown	Divertor Coolant Tubes	Divertor Plates			Shield & Support System Insp.			Divertor Plates	NDI Welds	Coolant Tubes Installation	Start-Up
Task	Shutdown & Prep for Maint.	Twenty-four Coolant Tubes (8 x 3 Sectors)	Cut Plates Coolant Tube Weld (8 x 3 Sectors)			Inspect Outside for Damage & Repair			Weld Plates Coolant Tube (8 x 3 Sectors)	Complete Coolant Tube Weld Inspect.	Twenty-four Coolant Tubes (8 x 3 Sectors)	
Time (Hrs)	30.00	9.40	20.40			12.00			26.40	0.55	13.10	38.00
Total Time (Hrs)	Disassembly 466.85 Hrs.						Replacement 739.55 Hrs.					
Total Time (Hrs)	Total Maintenance Time 1,206.40 Hrs. Inherent Availability 95.6%											

KEYS
Operational Tasks
Parallel/Simultaneous Tasks

Availability Analysis	Maint Days, Total	Maint Days/FPY	Availability
Summary of Maintenance Actions			
Scheduled Power Core, Major	50.27	16.76	95.6%
Scheduled Power Core, Minor	(ref ARIES-AT)	6.05	98.4%
Unscheduled Power Core	(ref ARIES-AT)	20.56	94.7%
Reactor Plant Equipment, Sched + UnSched	(ref ARIES-AT)	9.27	97.5%
Balance of Plant, Sched + UnSched	(ref ARIES-AT)	9.37	97.5%
		Total	84.7%



Coil material, configuration and structural design & analysis



Superconductor Options and Implications

- **Nb₃Sn wind and react (most conservative)**
 - Conventional design (ITER-like), but with high temperature inorganic insulation
 - Presently being tested for VLHC design (3-D winding in cos- θ magnets)
- **Nb₃Sn react and wind (less conservative)**
 - Thin cross section (low strain during winding)
 - MIT magnet for LDX (floating coil)
 - Low conductor current, internal dump
- **High T_c (most aggressive)**
 - Epitaxially deposited on structure
 - YBCO 2-generation superconductor
 - Potential for low cost (comparable to NbTi)

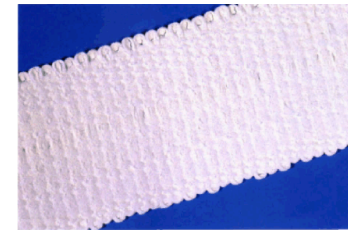

Ceramic insulation tape

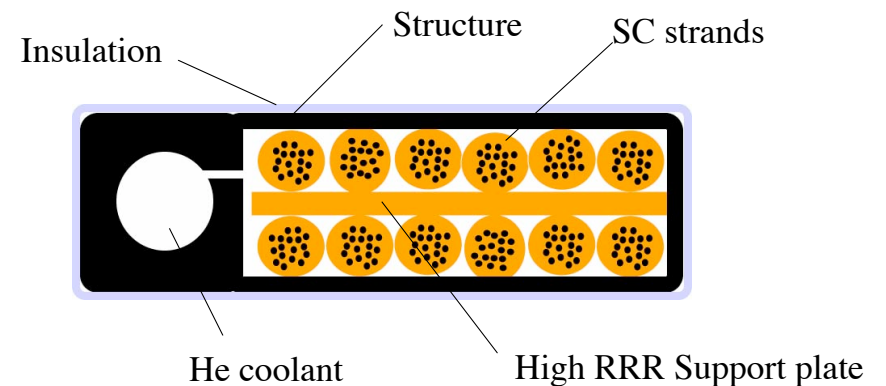

American Superconductor



Desirable Plasma Configuration should be Produced by Practical Coils with “Low” Complexity

- **Complex 3-D geometry introduces severe engineering constraints:**
 - Distance between plasma and coil
 - Maximum coil bend radius
 - Coil support
 - Assembly and maintenance
- **Superconductor: Nb₃Sn wind-and-react Cable-in-Conduit Conductor, wound on preformed structure (B≤16T)**
- **Coil structure**
 - JK2LB (Japanese austenitic steel chosen for ITER Central Solenoid)
 - Similar coefficient of expansion as SC, resulting in reduced SC strain
 - Relieve stress corrosion associated with Incoloy 908 (in the presence oxygen in the furnace during heat treatment)
 - Potentially lower cost
 - YS/UTS @4K similar to Incoloy 908 (1420/1690 MPa)
 - Need more weld characterization data

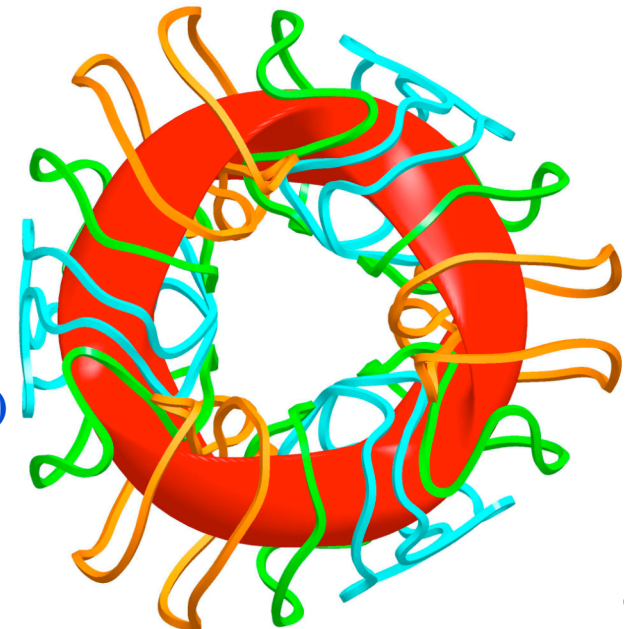

Coil Support Design Includes Winding of All Coils of One Field-Period on a Supporting Tubular Structure

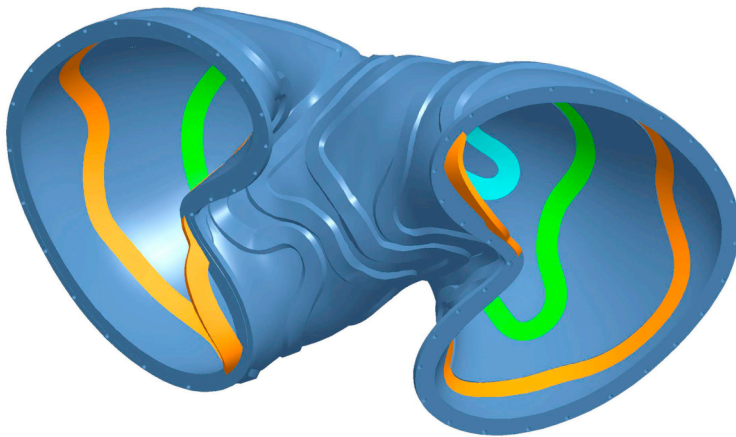

- Winding internal to structure.
- Entire coil system enclosed in a common cryostat.
- Coil structure designed to accommodate the forces on the coil

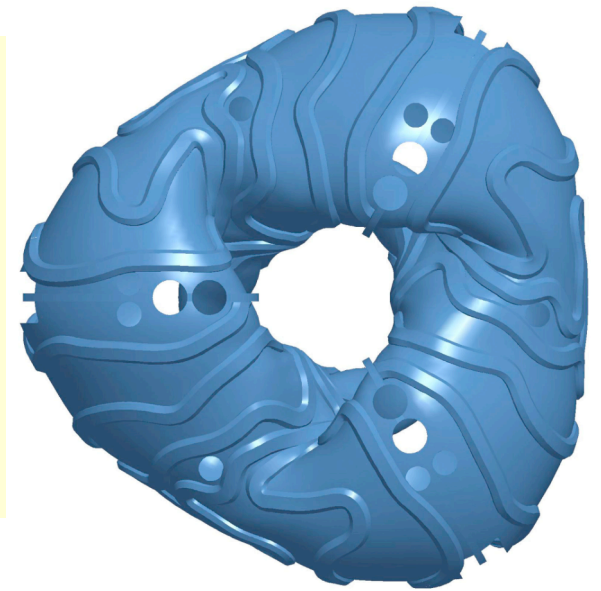

- Large centering forces pulling each coil towards the center of the torus.
- Out-of plane forces acting between neighboring coils inside a field period.
- Weight of the cold coil system.
- Absence of disruptions reduces demand on coil structure.

- Reacted by connecting coil structure together (hoop stress)
- Reacted inside the field-period of the supporting tube.
- Transferred to foundation by ~3 legs per field-period. Legs are long enough to keep the heat ingress into the cold system within a tolerable limit.

Detailed EM and Stress Analysis Performed with ANSYS

- Shell model used for trade-off studies
- Selected cases with 3-D solid model done for comparison to help better understand accuracy of shell model and effect of penetration
- As a first-order estimate, structure thickness scaled to stress & deflection results to reduce required material and cost; e.g. in this case:
 - Avg. thickness inter-coil structure ~20 cm
 - Avg. thickness of coil strong-back ~28 cm

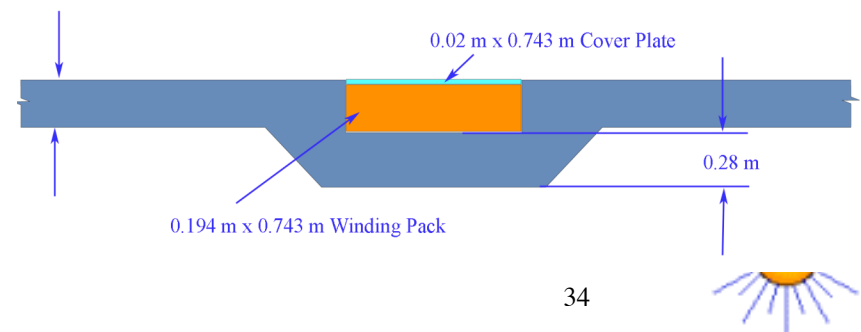
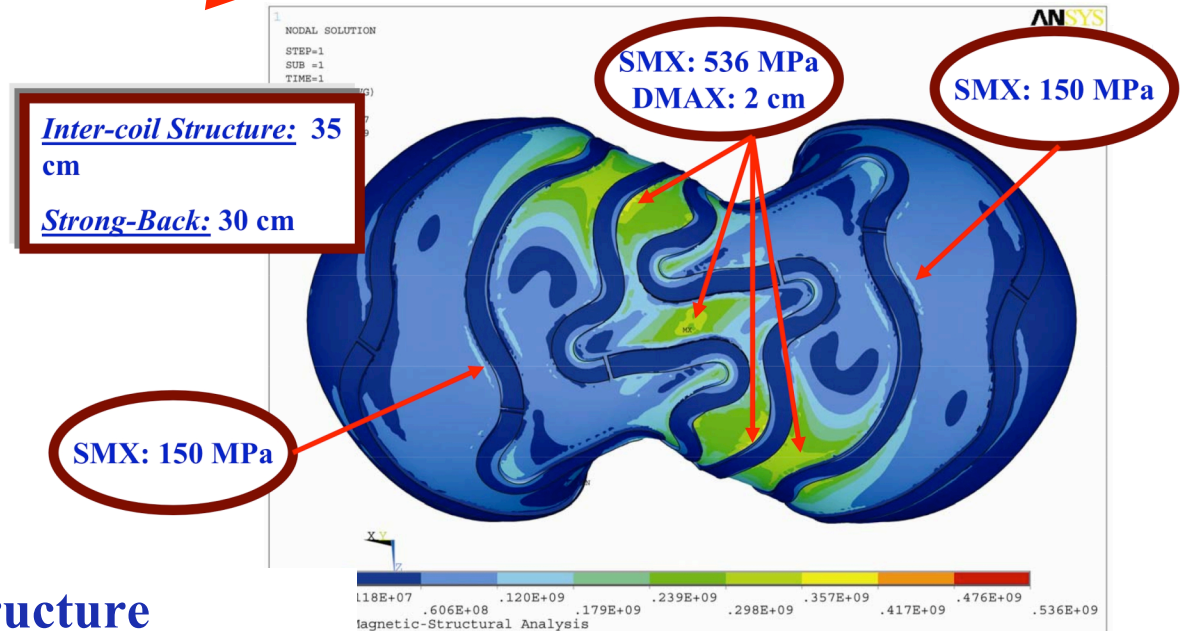

3-D Solid Model for 35-cm JK2LB Structure with Penetration and 30 cm Strongback

Displacement

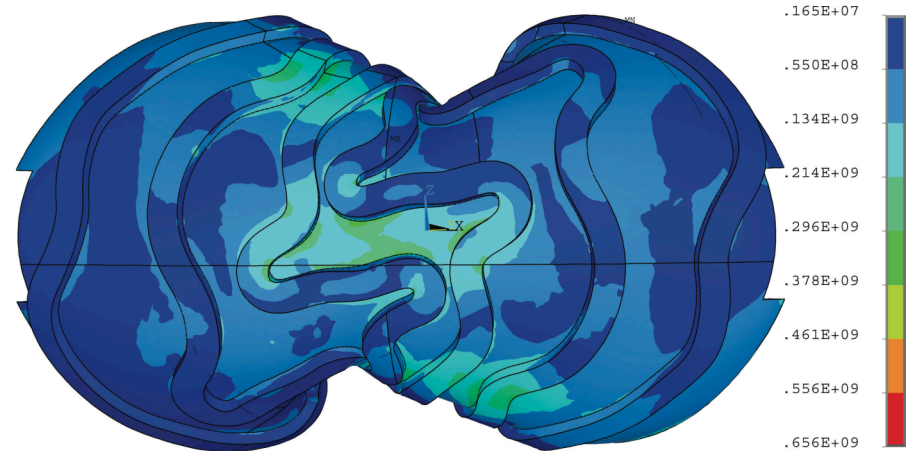
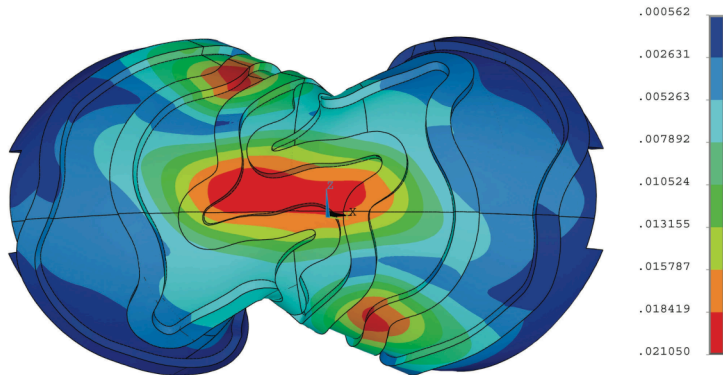

- No major concern if port penetration in low stress area
- Max. stress for this 3-D solid model is 656 MPa, compared to 536 MPa for 2-D shell model.
- Max. deflection about the same in both cases, ~ 2 cm. Need to be included in design of coil geometry.

Stress

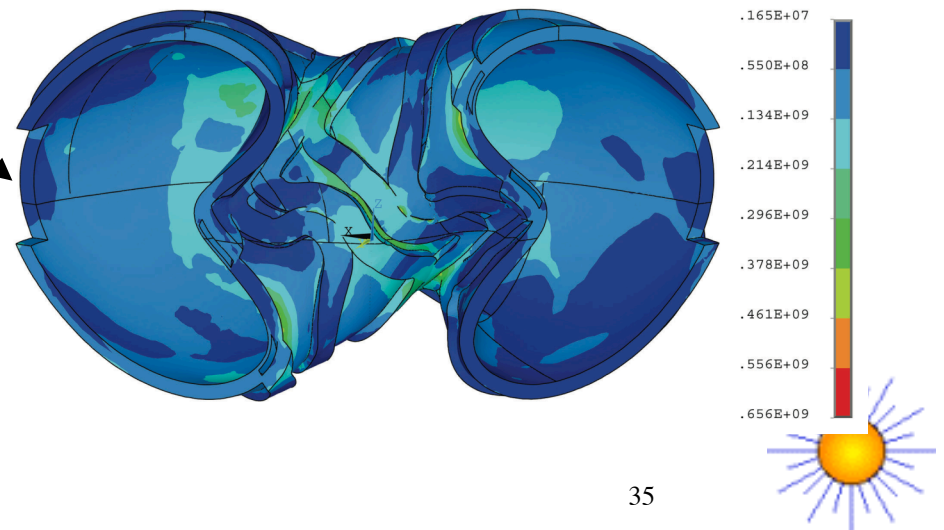

Divertor design



Divertor Physics Study for 3-FP ARIES-CS

- Location of divertor plate and its surface topology designed to minimize heat load peaking factor.
- Field line footprints are assumed to approximate heat load profile.
- Top and bottom plate location with toroidal coverage from -25° to 25° .
 - Optimization being conducted in concert with initial NCSX effort on divertor.
 - In anticipation of the final physics results, we proceeded with the engineering design based on an assumed maximum heat flux of 10 MW/m^2 .

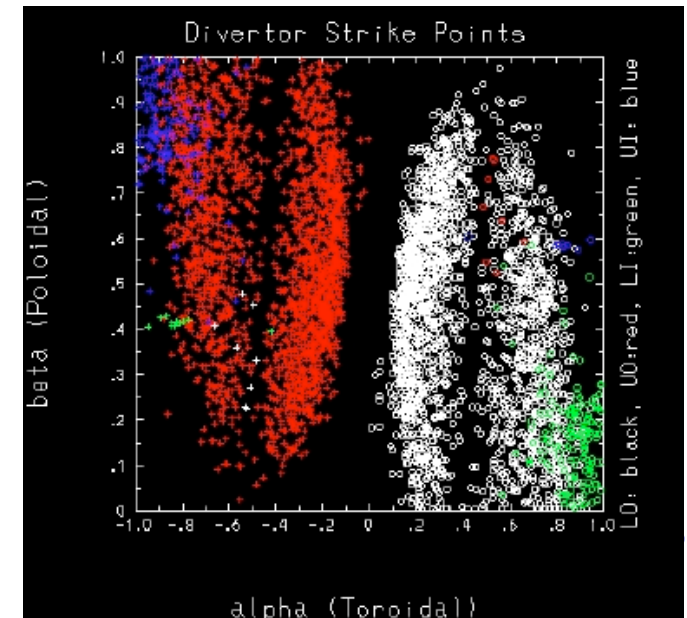
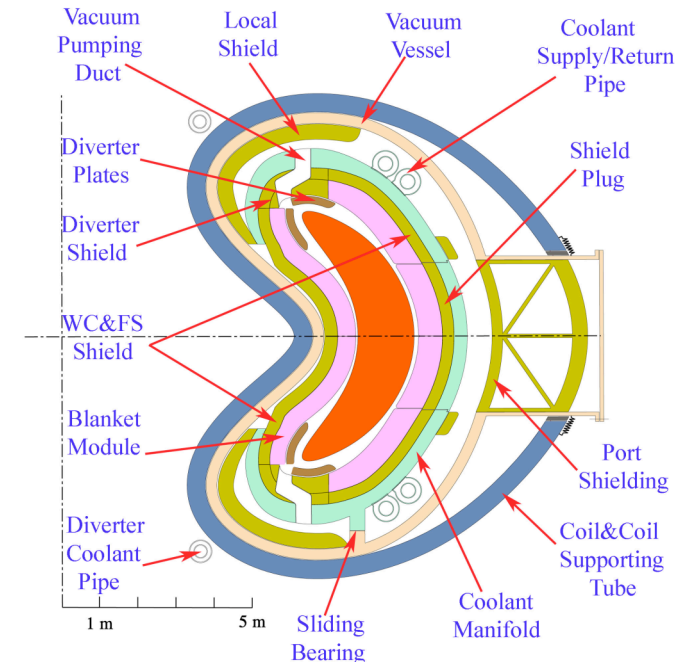

Comprehensive Power Flow Diagram Including Possibility of Added Power and Alpha Loss Flux Going to Both FW and Divertor

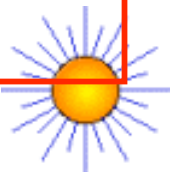
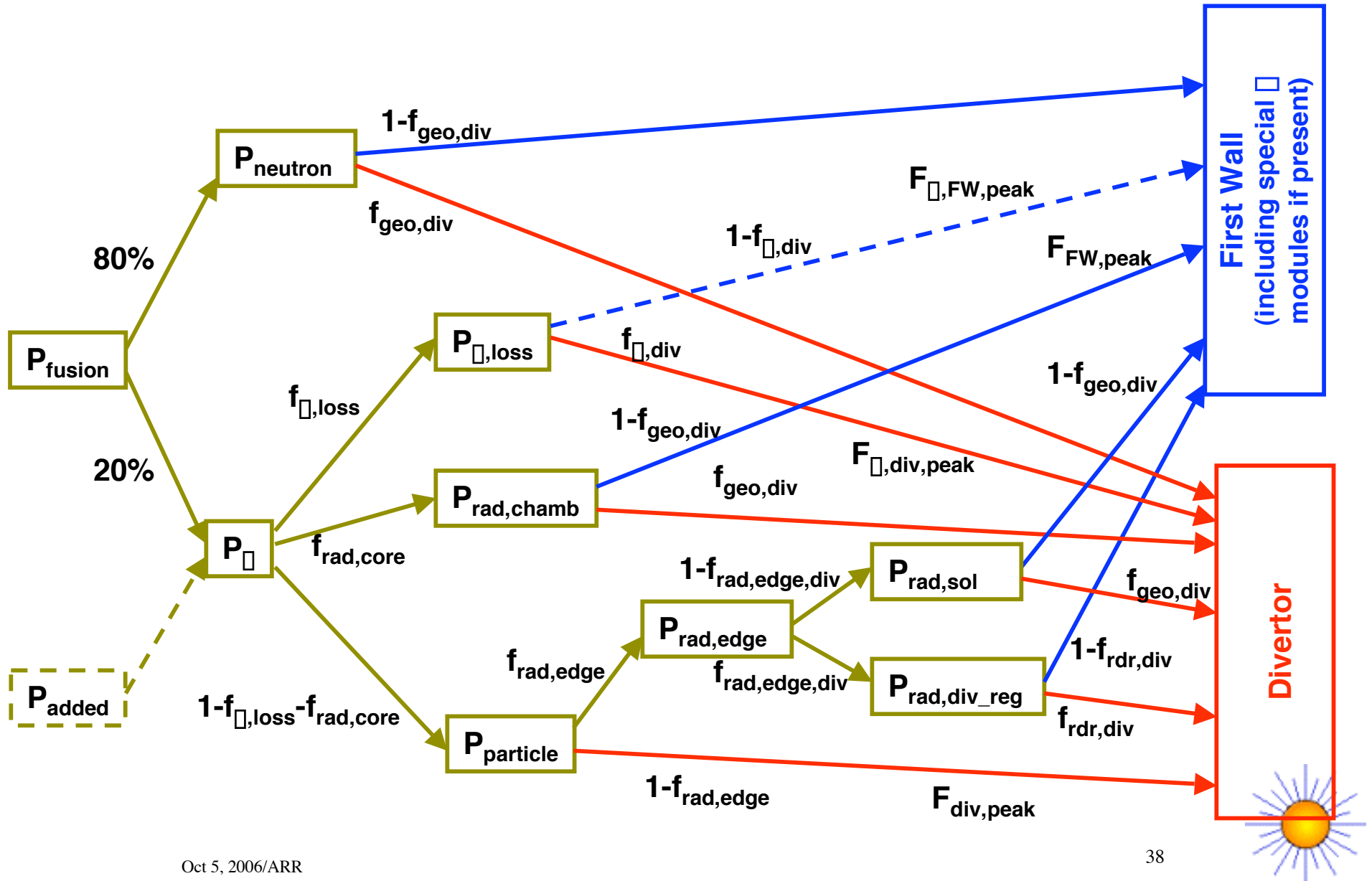

Combination of Fractional Core Radiation, Edge Radiation and Divertor Peaking Factor for Maximum Divertor $q'' = 10 \text{ MW/m}^2$

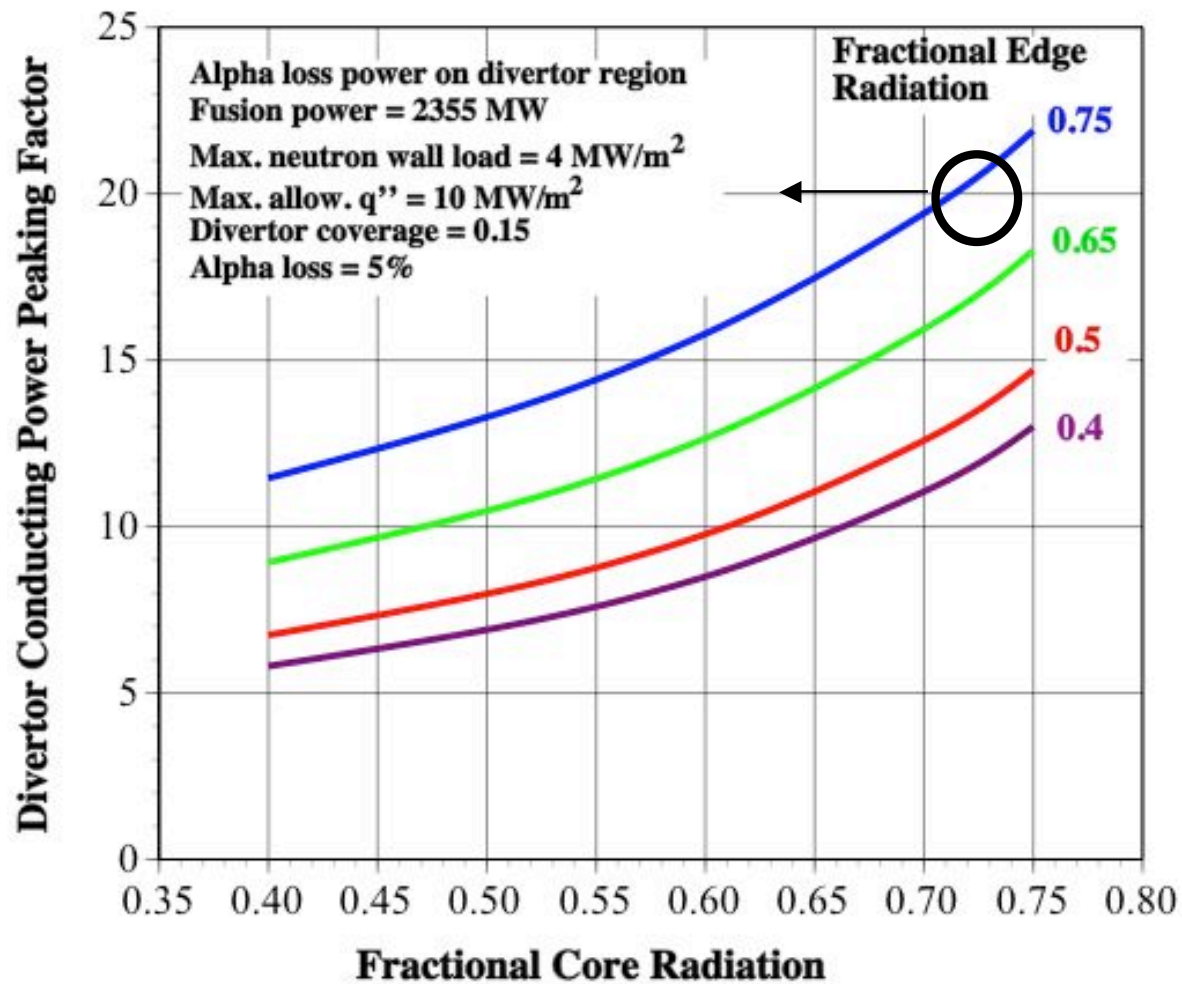

ARIES-CS Divertor Design

- Design for a max. q'' of at least 10 MW/m^2
 - Productive collaboration with FZK
 - Absence of disruptions reduces demand on armor (lifetime based on sputtering)
- Previous He-cooled divertor configurations include:
 - W plate design ($\sim 1 \text{ m}$)
 - More recently, finger configuration with W caps with aim of minimizing use of W as structural material and of accommodating higher q'' with smaller units ($\sim 1\text{-}2 \text{ cm}$) (FZK)
- Build on the W cap design and explore possibility of a new mid-size configuration with good q'' accommodation potential, reasonably simple (and credible) manufacturing and assembly procedures, and which could be well integrated in the CS reactor design.
 - "T-tube" configuration ($\sim 10 \text{ cm}$)
 - Cooling with discrete or continuous jets
 - Effort underway at PPI to develop fabrication method

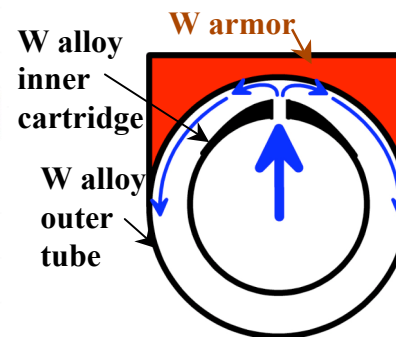
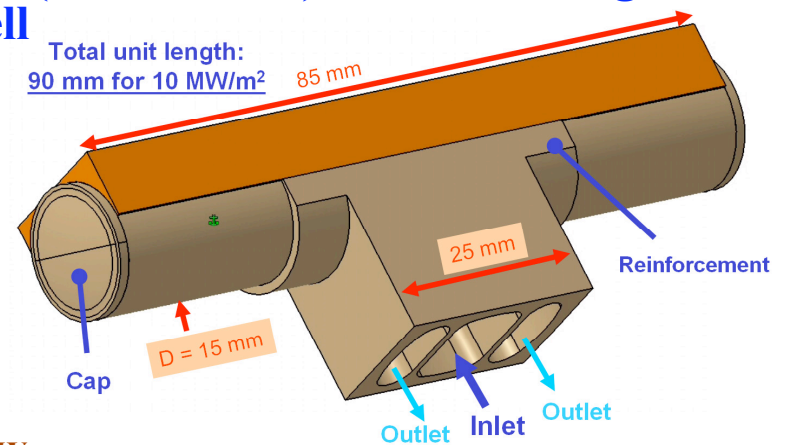
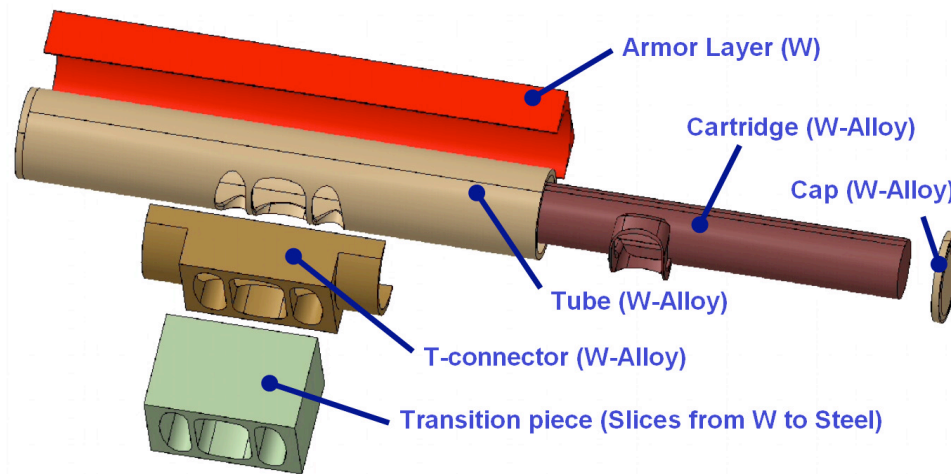

T-Tube Configuration Looks Promising as Divertor Concept for ARIES-CS (also applicable to Tokamaks)

- Encouraging analysis results from ANSYS (thermomechanics) and FLUENT (CFD) for $q'' = 10 \text{ MW/m}^2$:
 - W alloy temperature within $\sim 600\text{-}1300^\circ\text{C}$ (assumed ductility and recrystallization limits, but requires further material development)
 - Maximum thermal stress $\sim 370 \text{ MPa}$
- Results from experiments at Georgia Tech. seem to confirm thermo-fluid modeling analysis.

Example Case:

- Jet slot width = 0.4 mm
- Jet-wall-spacing = 1.2-1.6 mm
- Specific mass flow = 2.12 g/cm^2
- Mass flow per tube = 48 g
- $P = 10 \text{ MPa}$, $\Delta P \sim 0.1 \text{ MPa}$
- $\Delta T \sim 90 \text{ K}$ for $q'' = 10 \text{ MW/m}^2$
- $T_{\text{He}} \sim 605 - 695^\circ\text{C}$

Oct 5, 2006/ARR

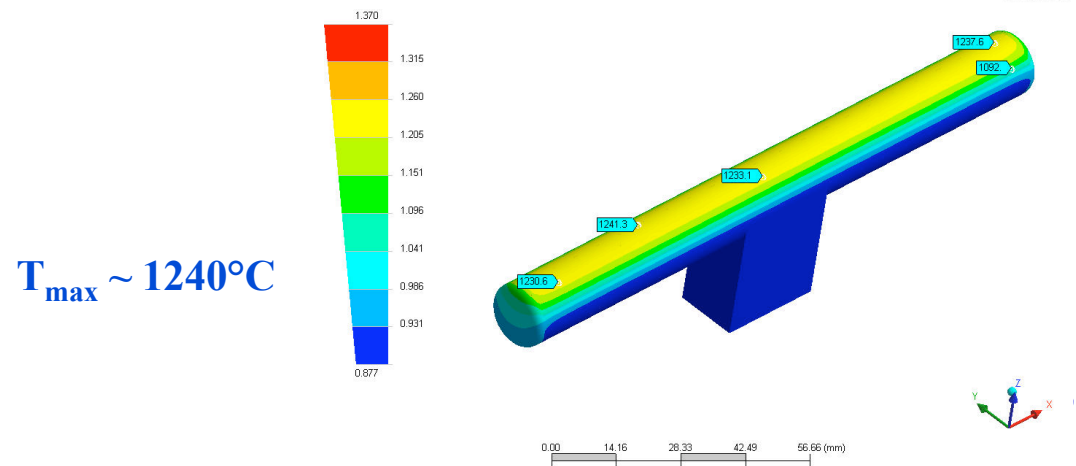
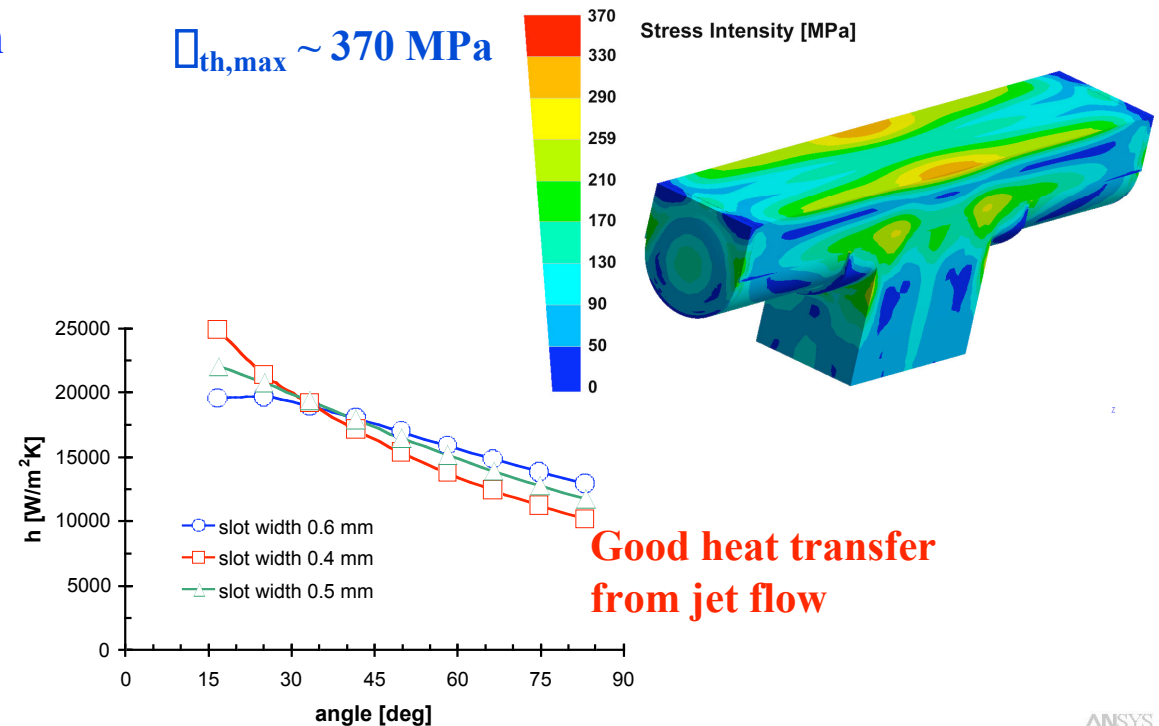

Experimental Verification of Divertor Performance

- Experiments have been conducted to verify the extremely high heat transfer coefficients ($> 40 \text{ kW/m}^2 \text{ K}$) predicted by the numerical models
- Axial and azimuthal distributions of the heat transfer coefficients have been measured with air at prototypical Reynolds numbers
- Excellent agreement has been obtained between experimental data and model predictions.

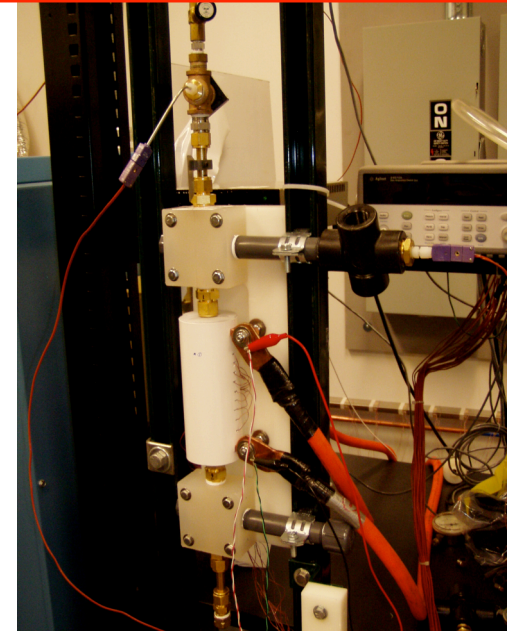

Experimental Results (two inlets) : Low Flow (Air)

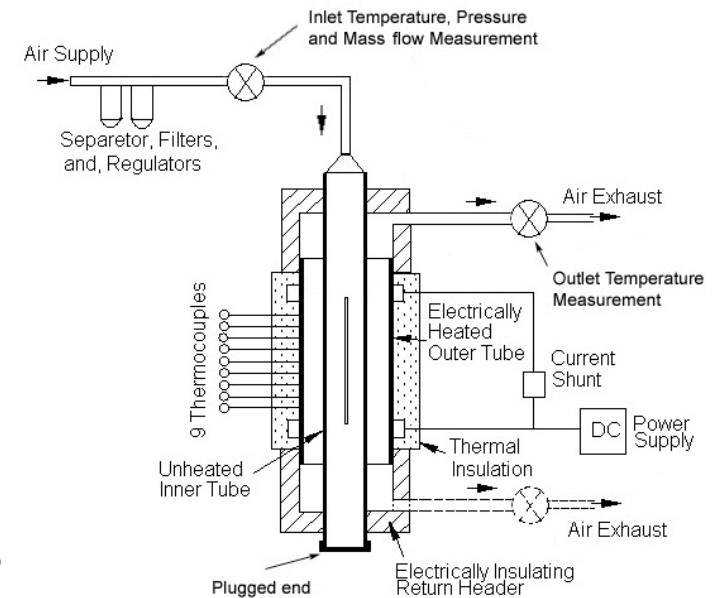
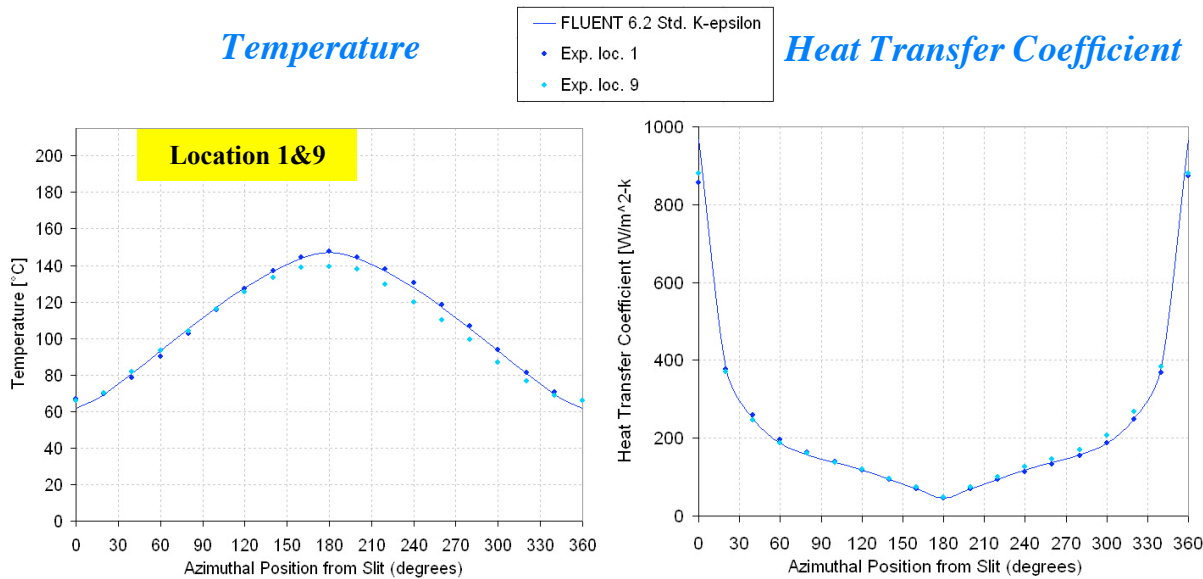

Divertor Manifolding and Integration in Core

- T-tubes assembled in a manifold unit.
- Typical target plate (~1m x 3 m) consists of a number of manifold units.
- Target plate supported at the back of VV to avoid effect of hot core thermal expansion relative to VV.
- Concentric tube used to route coolant and to provide support.
- Possibility of in-situ alignment of divertor plate if needed.
- 24 target plates in all.

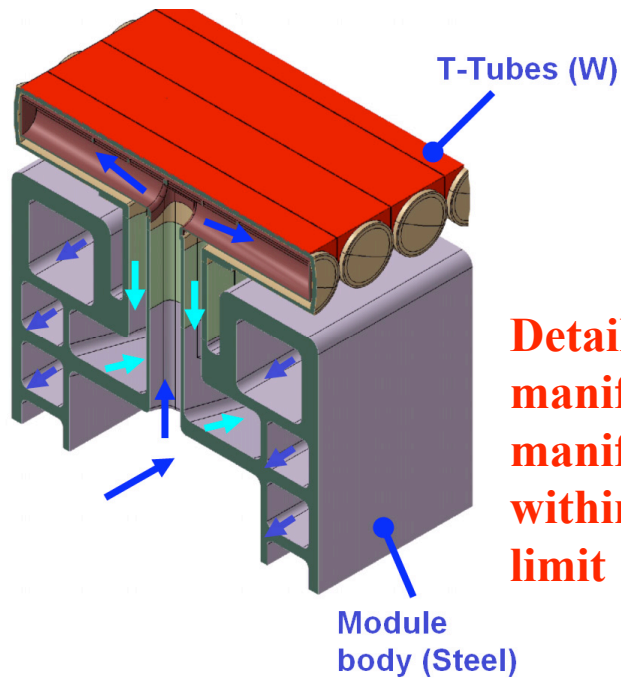

Details of T-tube manifolding to keep FS manifold structure within its temperature limit

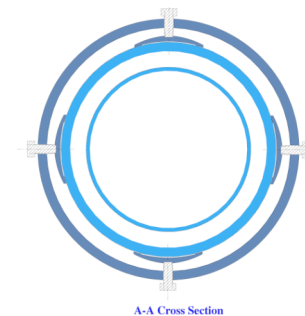
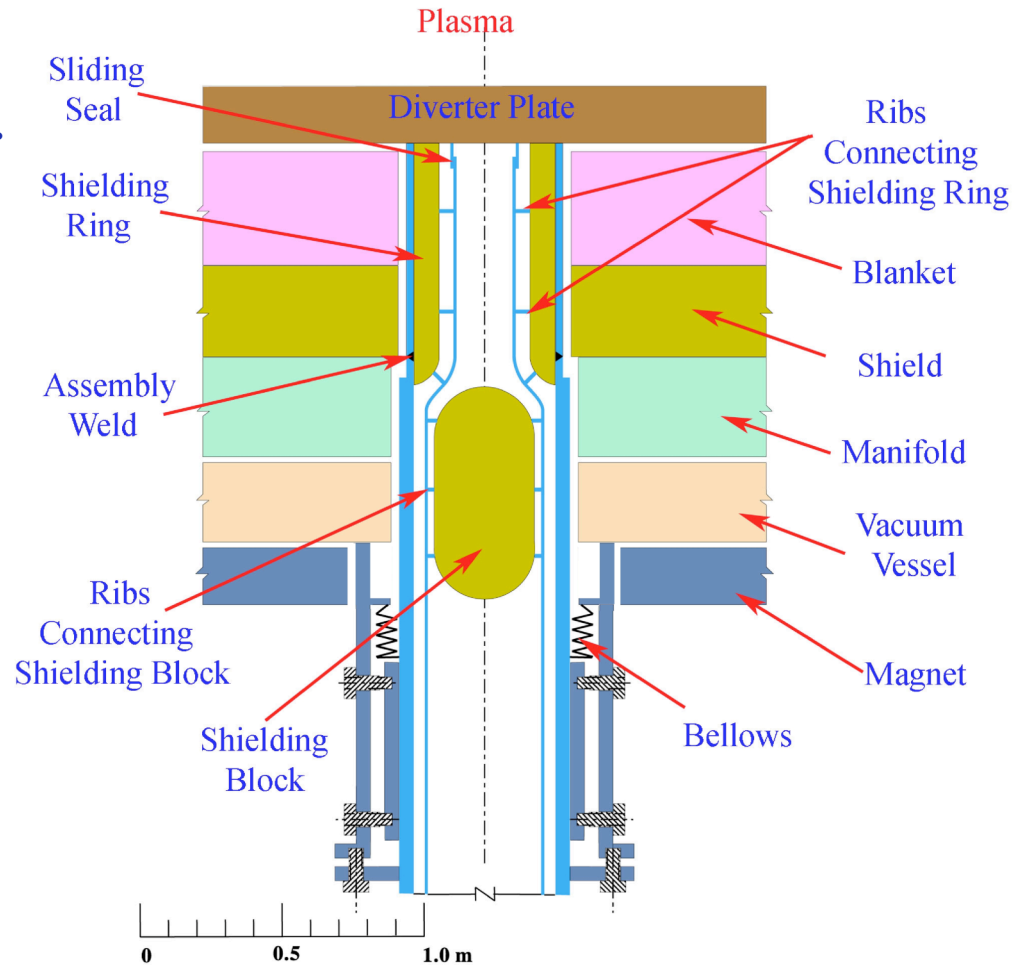

Details of Divertor and Pumping Port Integration in Power Plant

- Compactness of power plant restricts space and designing for adequate shielding is quite challenging (including providing for cooling the shield and replacing non-life-of-plant shielding components)
- Pumping duct size based on ARIES CS:
 - 30 divertor pumping ducts from plasma side to VV (42 x 120 cm each)
 - 12 Large pumping ducts for pumping from VV to outside (1 x 1.25 m each)
- Base pressure (NCSX-like) ~ 1mTorr; turbo pumps used.

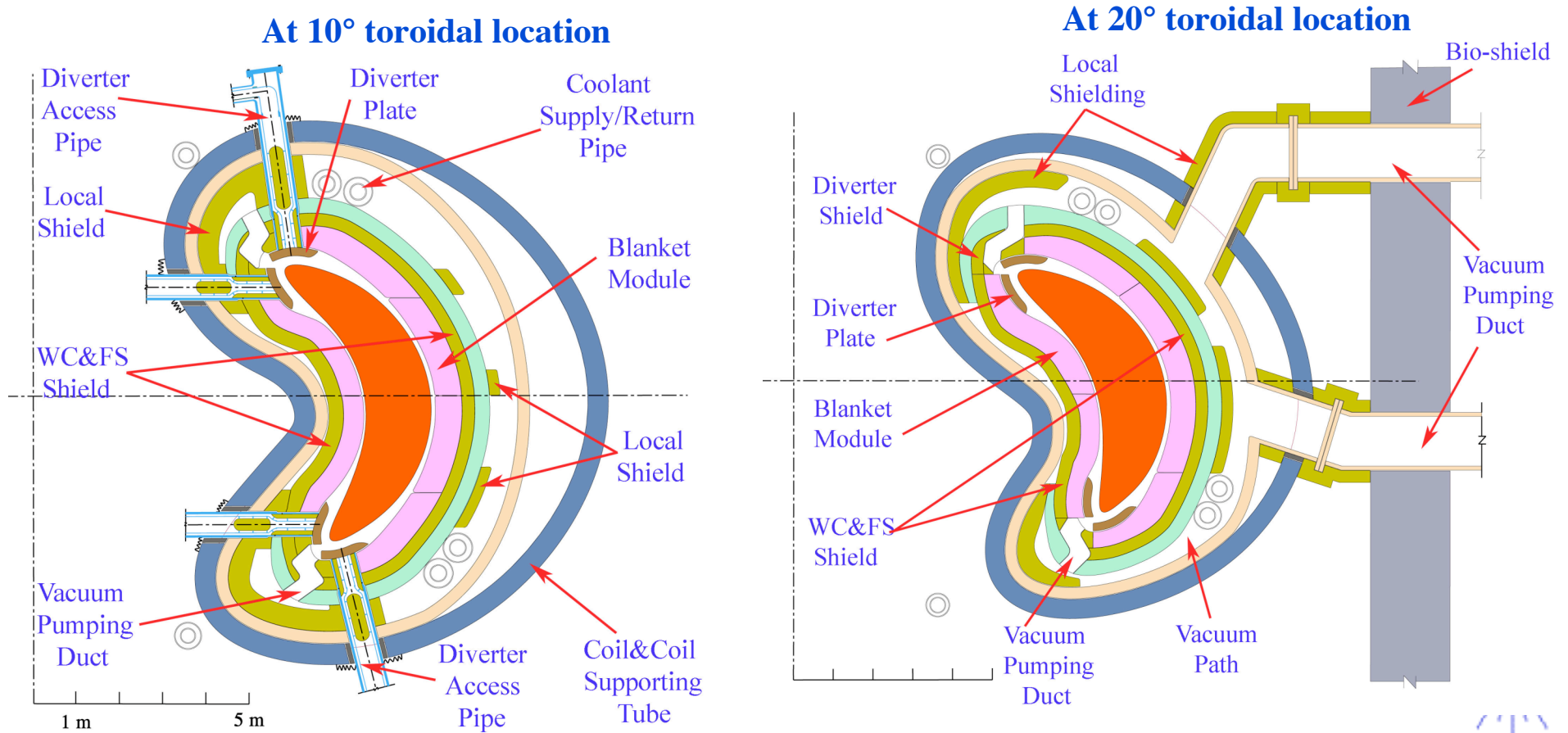

Alpha Loss



Accommodating Alpha Particle Heat Flux

- Significant alpha loss in CS (~5%) represents not only loss of heating power in the core, but adds to the heat load on PFC's.
- High heat flux could be accommodated by designing special divertor-like modules (allowing for q'' up to $\sim 10 \text{ MW/m}^2$).
- Impact of alpha particle flux on armor lifetime (erosion) is more of a concern.
- Possibility of using nanostructured porous W (from PPI) to enhance implanted He release e.g. 50-100 nm at $\sim 1800^\circ\text{C}$ or higher

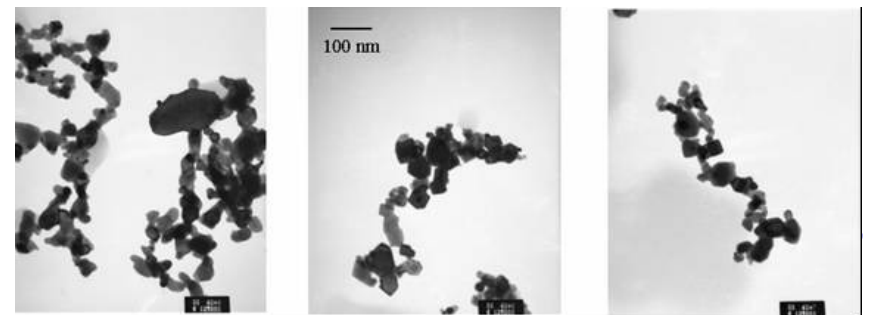
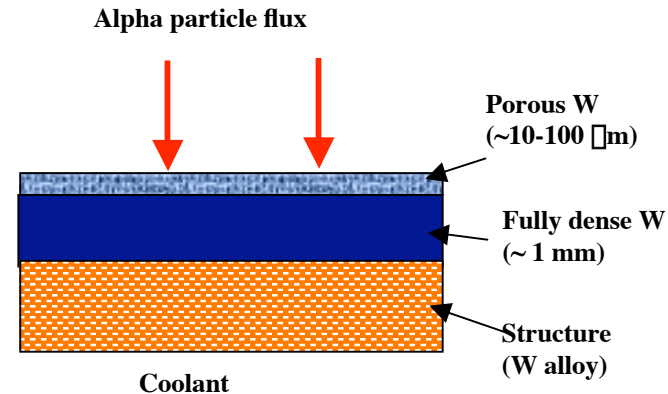

Safety and Environmental Analysis



Safety Requirements

- **The DOE Fusion Safety Standard enumerates the safety requirements for magnetic fusion facilities, two primary requirements are:**
 - **The need for an off-site evacuation plan shall be avoided, which translates into a dose limit of 10 mSv at the site boundary during worst-case accident scenarios (frequency $< 10^{-6}$ per year)**
 - **Wastes, especially high-level radioactive wastes, shall be minimized, implying that all radioactive waste should meet Class C, or low level, radioactive waste burial requirements**
- **To demonstrate that the no-evacuation requirement has been met, accidents that challenge the radiological confinement boundaries (e.g., confinement bypass accidents) must be examined.**



Confinement Strategy for ARIES-CS

- **ARIES-CS has adopted the confinement strategy call Defense-in-Depth, by establishing multiple radioactive confinement barriers between the radioactive source terms in the ARIES-CS vacuum vessel (VV) and the environment. For ARIES-CS these barriers are: VV, cryostat, heat transport system vault, and auxiliary rooms that adjoin to the cryostat**
- **The radioactive source terms of concern are:**
 - **Tritium implanted into plasma facing components (PFC)**
 - **Activated dust generated by PFC erosion (W)**
 - **Po-210 and Hg-203 produced by irradiation of the PbLi**
- **Energy sources that can challenge the confinement barriers are:**
 - **High pressure helium from the first wall (FW)/blanket wall cooling and secondary Brayton cycle systems**
 - **Decay heat**



Reference Accidents

Accidents that have been addressed

- **A Complete-loss-of-site power (CLOPA) or station blackout to demonstrate passive decay heat removal**
- **In-vessel helium loss-of-coolant accident to assess VV pressurization**
- **A double tube failure, which is a breach of the FW helium cooling system that precipitates a failure of a heat exchanger tube Brayton cycle**

Accidents that will be addressed

- **Ex-vessel helium LOCA analysis to determine heat transport system vault pressurization.**
- **Ex-vessel PbLi LOCA to determine Po-210 and Hg-203 release.**



ANSYS FE Model and Boundary Conditions for Thermal Analyses

- VV is operating in a natural convection mode for removing decay heat with the outside of the VV set at an adiabatic boundary condition.
- Model is axisymmetric about plasma centerline and symmetric on sides.
- Emissivity of 0.3 assumed across vacuum gap and vacated cooling channels.
- Emissivity of 0.5 assumed for SiC liner in blanket
- All analyses assume there is no helium in channels.

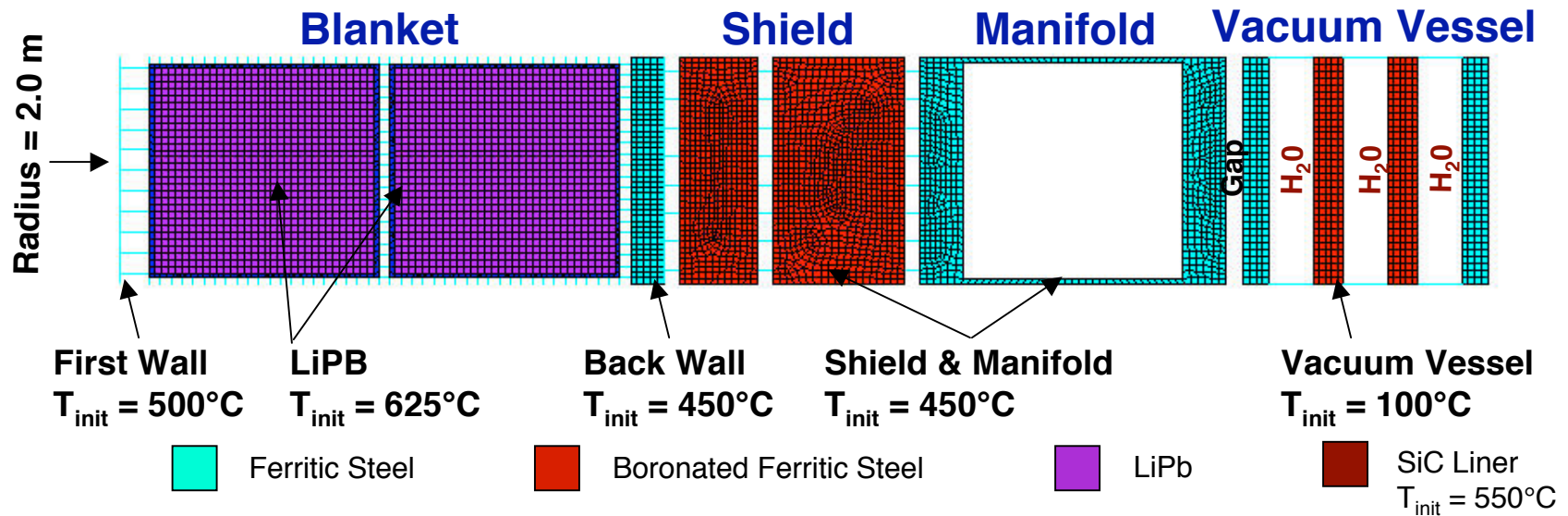

Thermal Results LOFA for LiPb and Water and LOCA for He

- Blanket radial heat transfer to the VV, conduction and radiation, maintain blanket below critical operating or reuse temperature limit

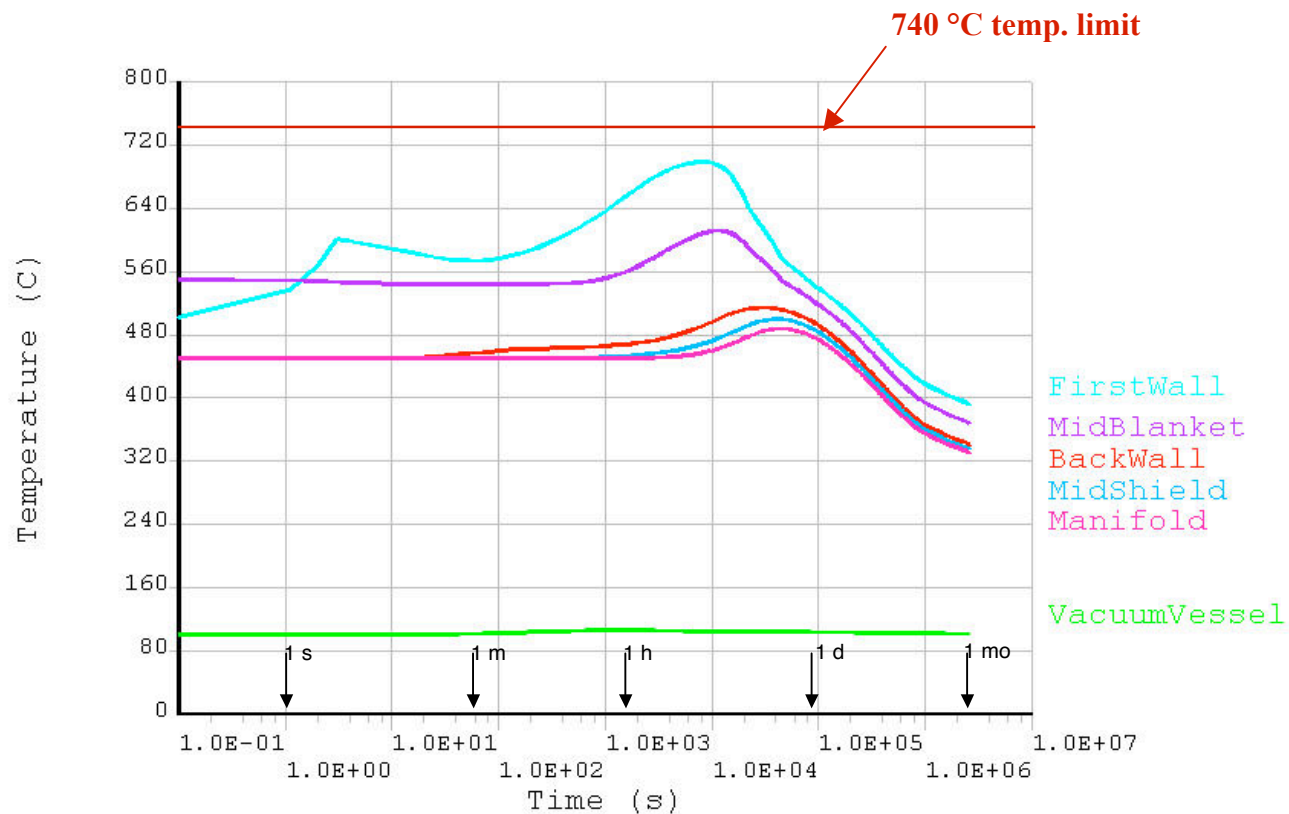

MELCOR ARIES-CS Model Schematic used in Pressurization Accidents

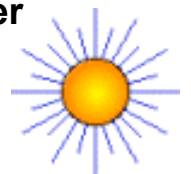
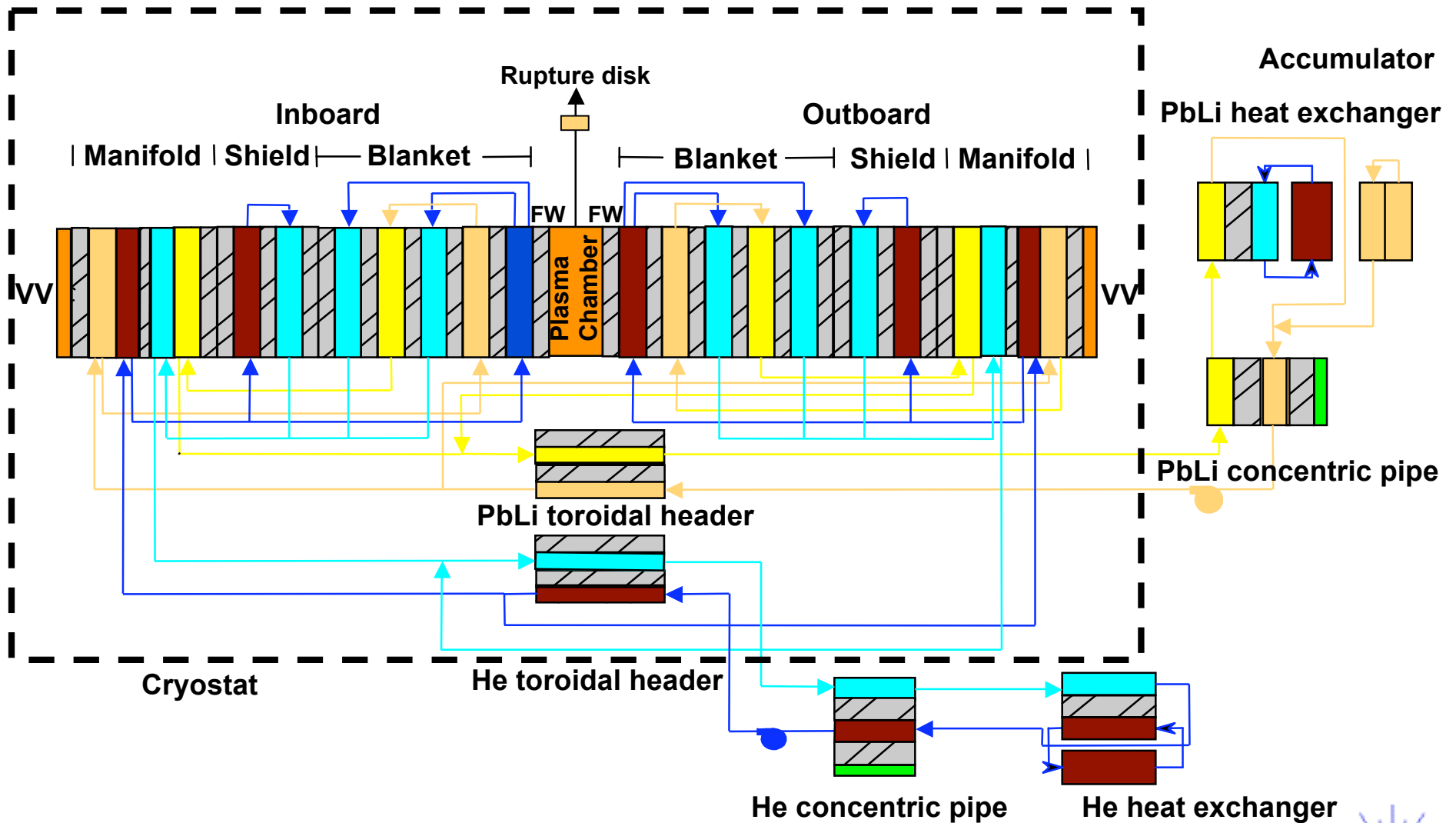

Double Break Accident Scenario does Not Fail Final Confinement Boundary

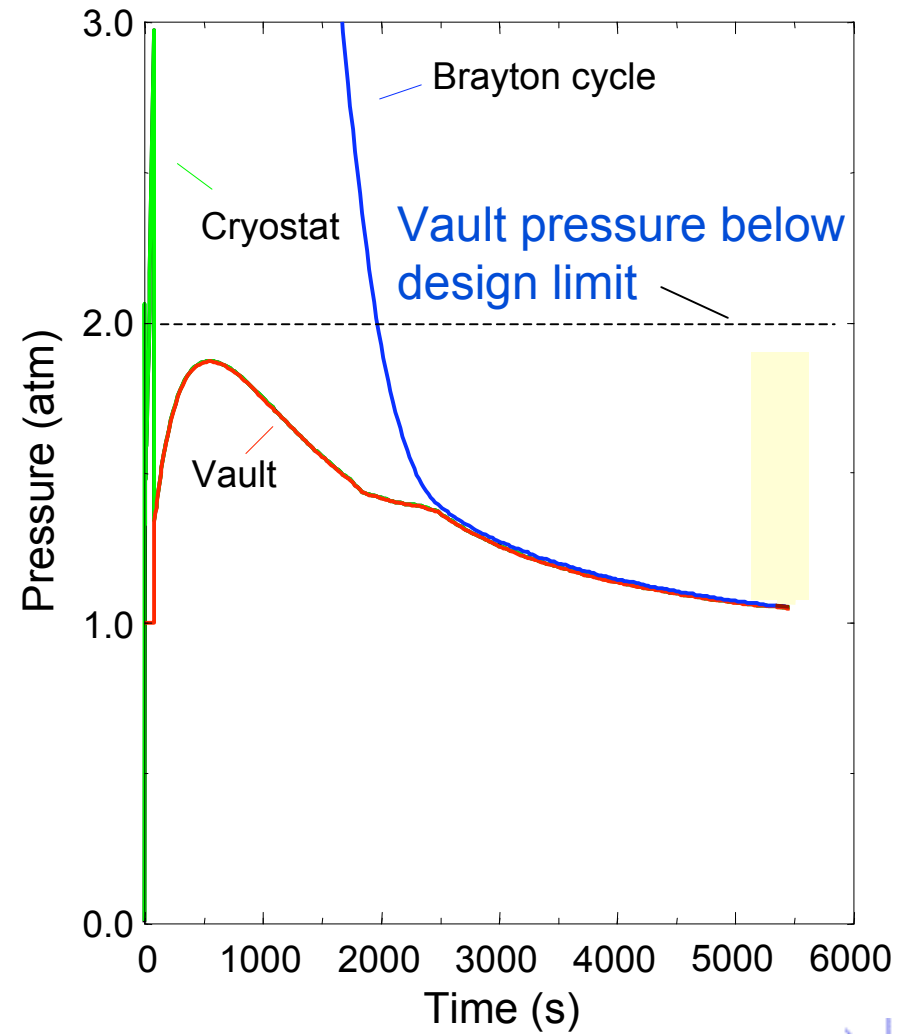
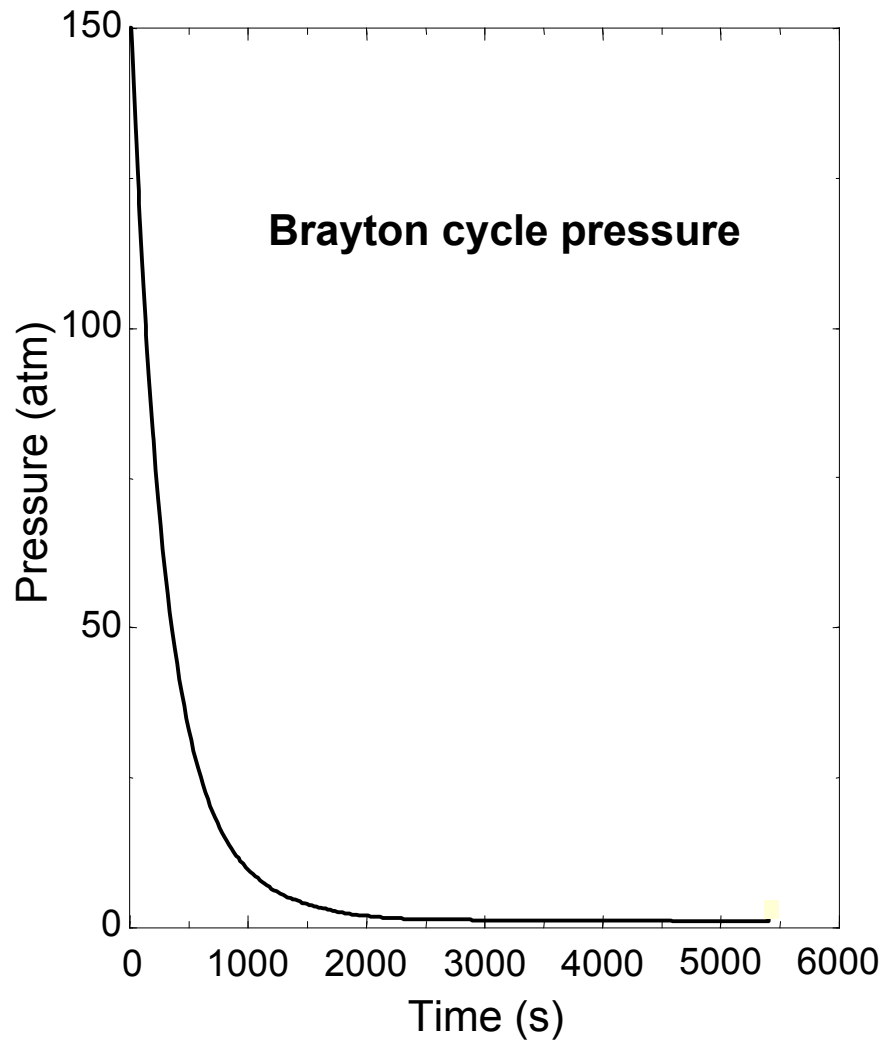

ARIES-CS Generates Only Low-Level Waste

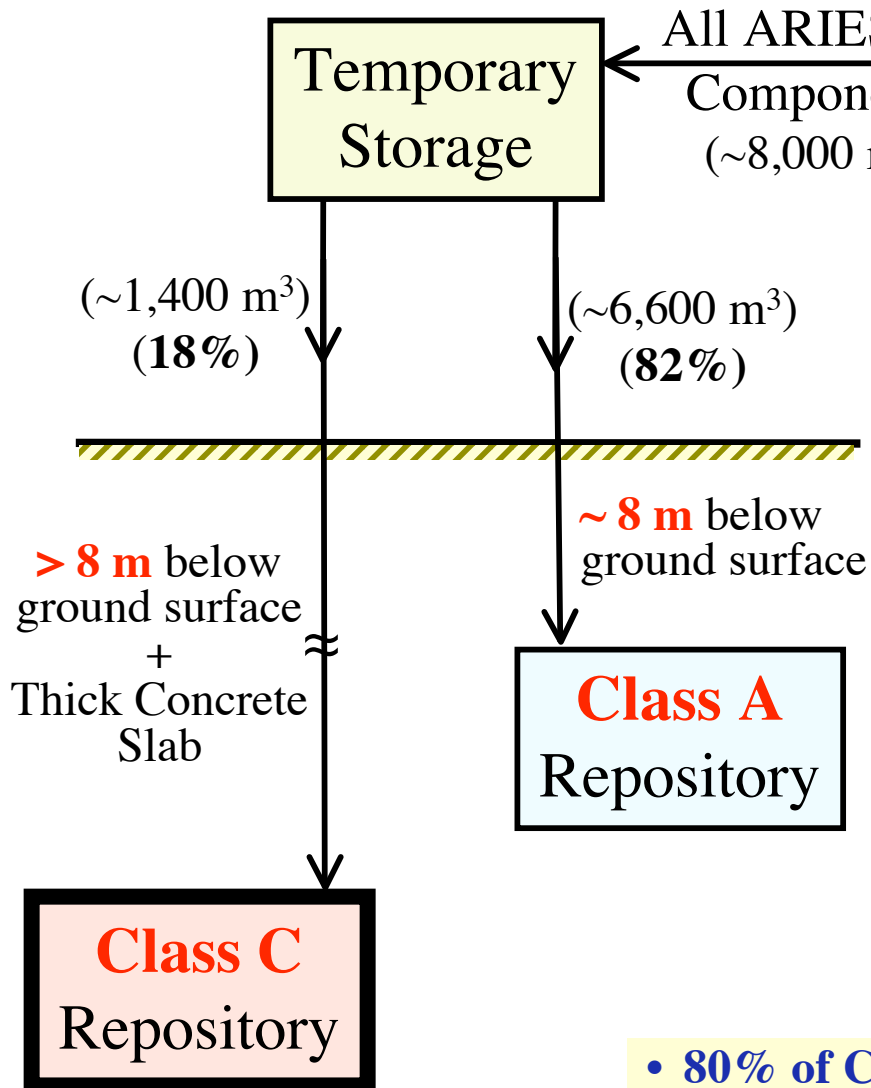
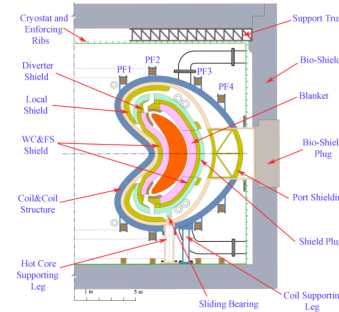

	Class C LLW	Class A LLW	Could be Cleared?
FW/Blkt/BW	✓		no
Shield/Manifolds	✓		no
Vacuum Vessel		✓	no
Magnet:			
Nb ₃ Sn	✓		no
Cu Stabilizer		✓	✓
JK2LB Steel		✓	✓
Insulator		✓	✓
Cryostat		✓	✓
Bioshield		✓	✓

- 80% of Class A waste can be cleared in < 100 y after decommissioning.
- All components could potentially be recycled.

ARIES Committed to Waste Minimization

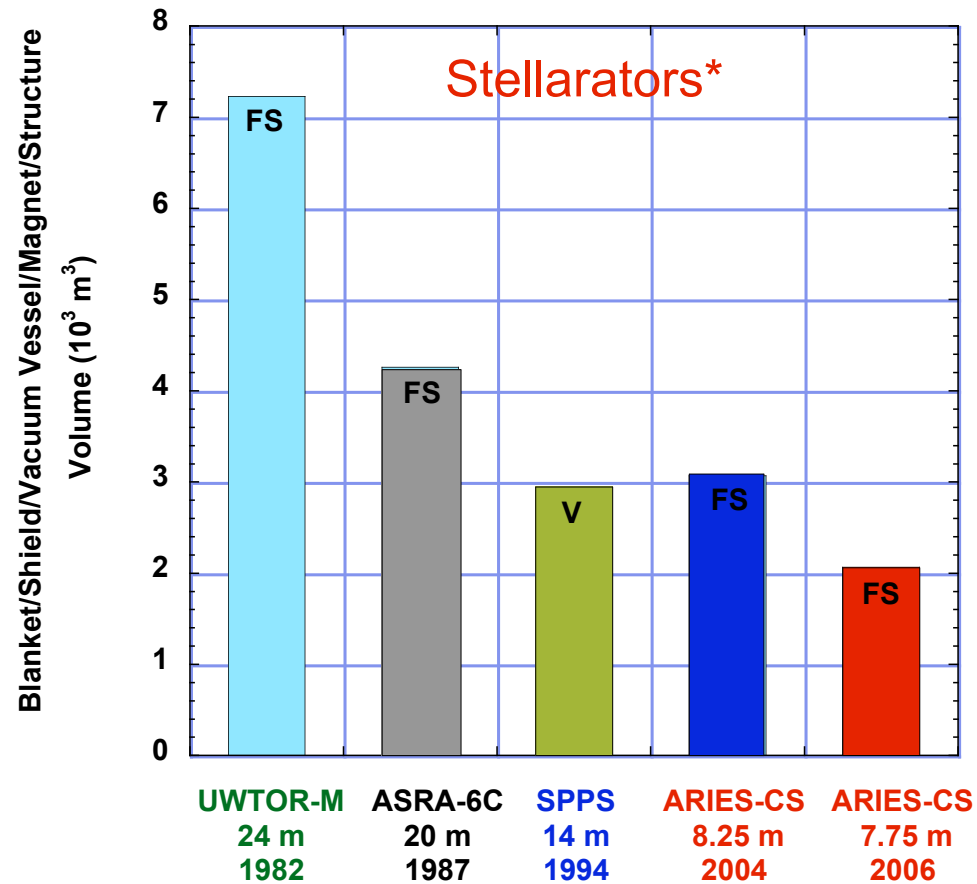

ARIES-CS volume represents 1/3 of UWTOR-M volume

* Actual volumes (not compacted, no replacements).



Low-Cost, Advanced Fabrication of Coil Structure



Summary of Advanced Fabrication of the Coil Structure

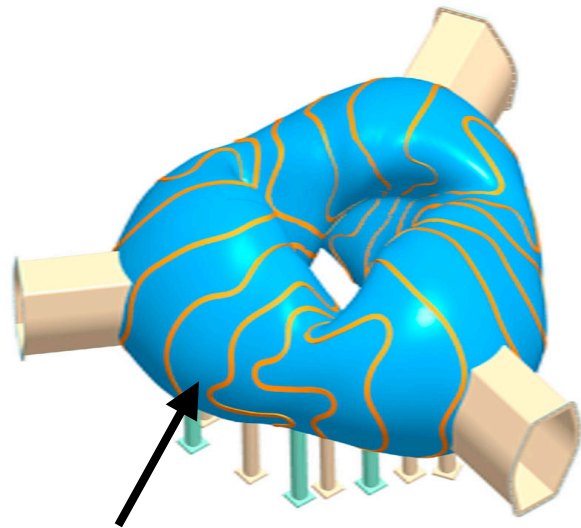

Interior grooves show on exterior for clarity

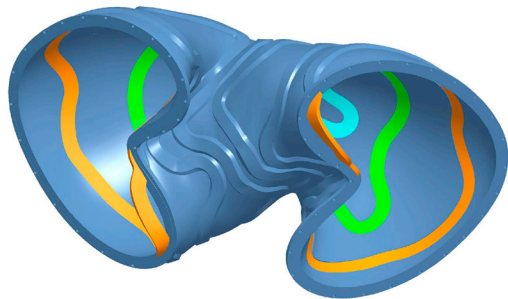

Material: JK2LB low carbon, boron steel

Mass: $\sim 3 \times 10^6$ kg for 3 field periods

Construction: Monolithic for entire field period

Fabrication Location: At construction site

Fabrication: Additive machining – arc deposition of near net shape, final machining of coil grooves by robot milling machines on inner surface and field period interfaces

Coil Fabrication: Coil cables will be wound into the grooves with robot winding machines

Accuracy of Coils: EM forces will be analyzed to determine displacement. Placement of the grooves will be compensated so the coils will be in proper location when coils are energized.



Plasma Arc Deposition

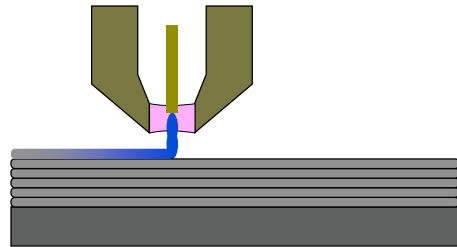

Planar Features

The deposition wire is fed into the plasma arc and the material deposited in layers

Overhanging Features

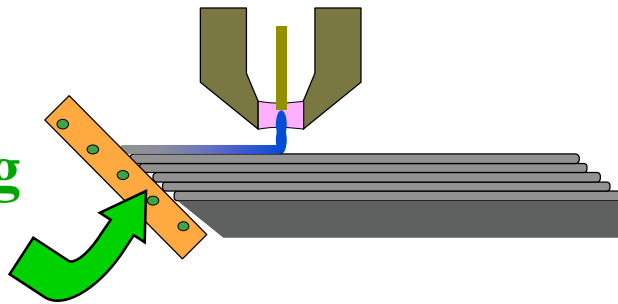

Overhanging features can be created with cooled slip plates

Near Net Shape Grooves

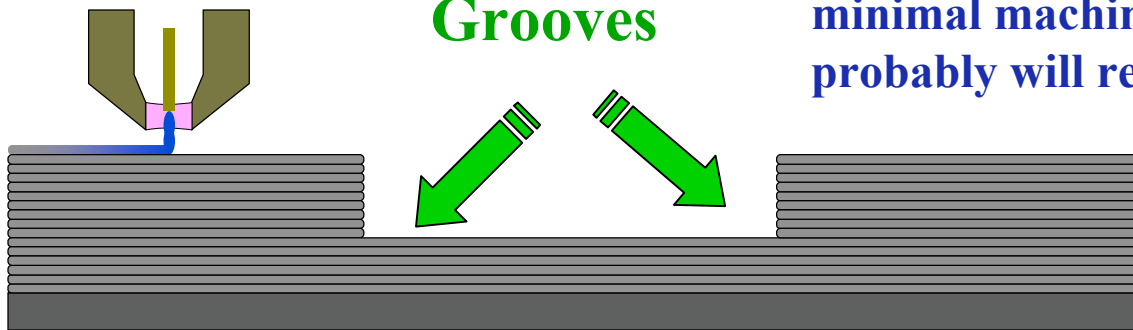

Near net shape grooves can be created as the material is deposited by starting and stopping the deposition. These features require only minimal machining. All other surfaces probably will require no machining.



Groove Fabrication

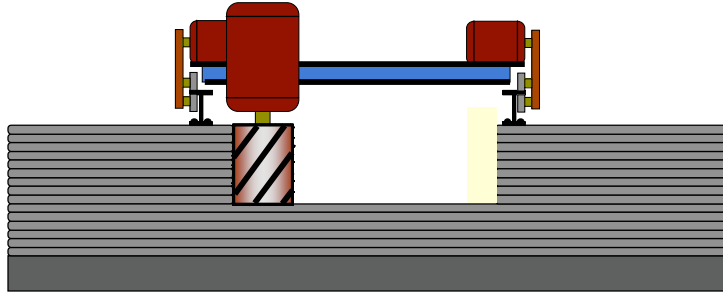

Guide rails and fiducial reference datums will be added to the structure parts to guide the milling machines for final groove machining.

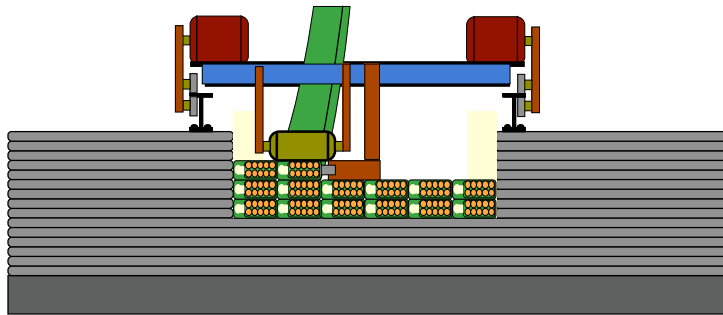

A similar machine will use the same rails and fiducial datums to install the superconducting cables into the coil groove

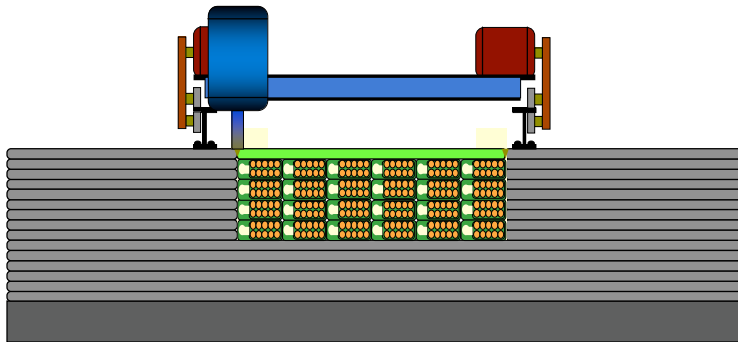

After all the cable is in place for the coil, the cover plate will be installed and friction-stir welded in place to secure the coil.



Concept to Fabricate Structure

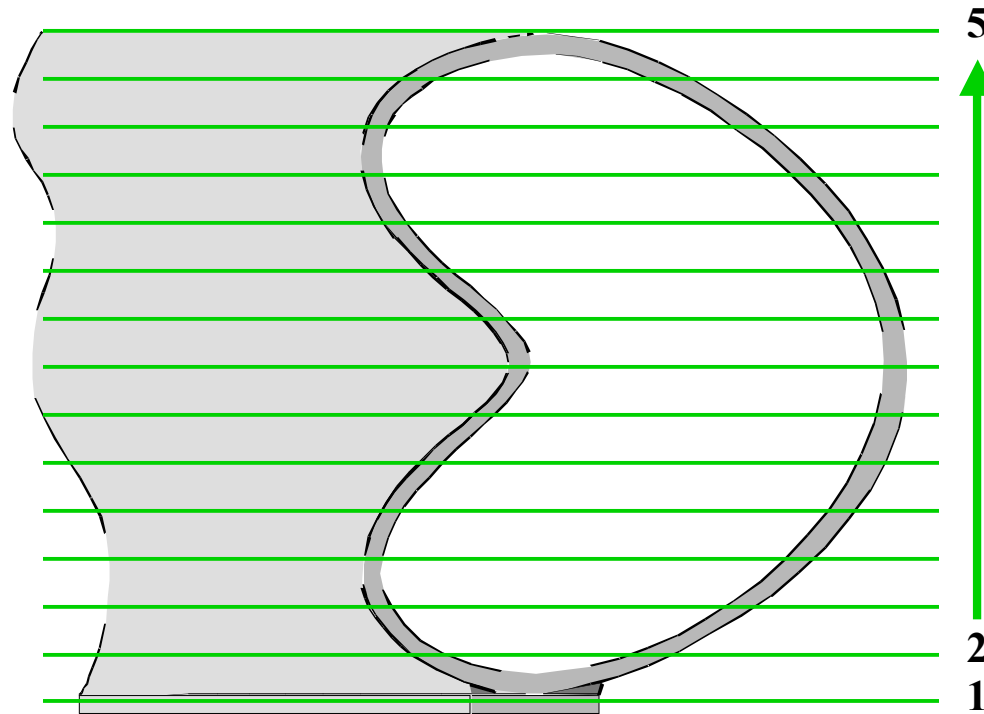

1. **Start with solid base**
2. **Begin to create structure**
3. **Continue to add layers**
4. **Ditto**
5. **Until it is complete for a field period**



Staging of Field Period Structures

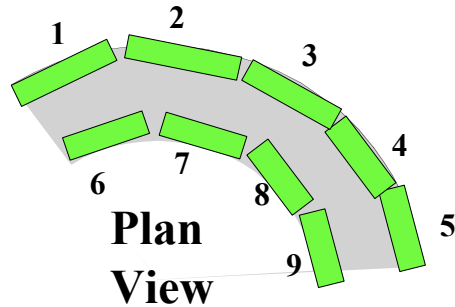

- Multiple deposition robots will be required to build a field period in roughly a year
- Each deposition robot will be assigned a zone to build

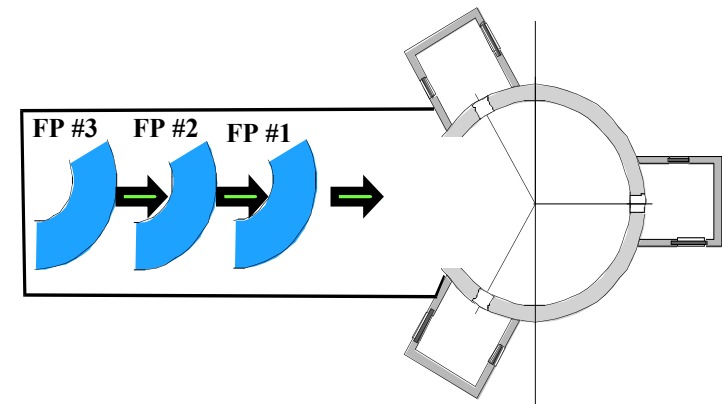
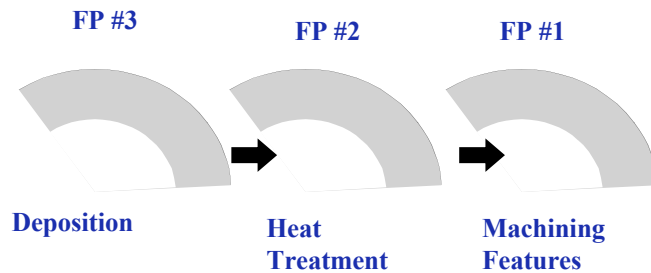

- The most cost effective approach is to construct one field period at a time, but staged to move deposition, heat treatment, and machining equipment from one FP to another as required.
- After the first FP is completed, it will be moved into place in the Reactor Building.
- All three FPs should be completed in roughly 3 years.

- The coil sectors will probably be fabricated close to the Reactor Building and moved inside the Reactor Building



Preliminary Costing

- A preliminary engineering cost estimate has been developed
- Additional detail can be added as needed
- Costs will be presented in \$2006
- Total mass is 10^6 kg ($393\text{m}^3 \times 7800 \text{ kg/m}^3$)
- Cost of specialty steel, JK2LB, in wire form is \$20/kg (estimate)
- Build each segment (FP) separately in sequence
- Build Time is driven by deposition rate, but is adjustable by using more robots (10 assumed)



Summary Schedule and Costs

Cost/Segment	\$	\$29,308,481
Mass Cost/Segment	\$/kg	\$29.31
Cycle Time for Segment 1	days	380
Additional Time for Each Additional Segment	days	245
Total Time for 3 Segments	days	870

Labor costs are $< \frac{1}{2}$
the cost of raw
material costs!

Fabrication Elements	Days	Cost
Deposition	245	\$25,720,588
Stress Relief	30	\$1,648,000
Coil Channel Machining	24	\$591,957
Coil Cable and Cover Installation	61	\$592,445
Cooling Channel Machining	8	\$359,334
Cooling Channel Closeout	11	\$396,157
Segment Totals (d, \$)	380	\$29,308,481
Total, Three Segments (d,\$)	870	\$87,925,443

~ 2.4 yr fabrication

This is a good approximation of the coil structure fabrication cost using advanced low cost techniques that will have no complexity factor. This compares to much more expensive conventional fabrication approach that has high labor costs and significant complexity factors.



Summary (I)

- **Design point pushed to the limit for “compact” configuration with low aspect ratio; might be better to relax some parameters (e.g. major radius) to provide more margins on space and material stress/temperature limits.**
- **Assembly & maintenance, and penetration shielding are major factors in configuration optimization because of geometry and space constraints.**
- **Integration is particularly important because of interfaces and mutual impact of changes in one system design on others, including: modular coil design and structural support, power core design and maintenance & assembly.**
- **Alpha loss is a key issue: heat flux can be handled with divertor-like modules but He implantation needs focused R&D to find an engineering solution (perhaps with a porous nano-structured W armor).**

Summary (II)

- **Engineering effort has yielded some interesting and some new evolutions in power core design.**
 - **Novel blanket/shield approach to minimize plasma to coil minimum distance and reduce machine size.**
 - **First ever 3-D modeling of complex stellarator geometry for nuclear assessment using CAD/MCNP coupling approach.**
 - **Separation of hot core components from colder vacuum vessel (allowing for differential expansion through slide bearings).**
 - **Design of coil structure over one field-period with variable thickness based on local stress/displacement; when combined with rapid prototypic fabrication technique this can result in significant cost reduction.**
 - **Mid-size divertor unit (T-tube) applicable to both stellarator and tokamak (designed to accommodate at least 10 MW/m²).**
 - **Possibility of in-situ alignment of divertor if required.**
 - **Significant reduction in stellarator radwaste stream.**
 - **Decay heat removal in ARIES-CS can be achieved by VV in natural convection mode.**
 - **Pressurizations events do not fail all ARIES-CS confinement boundaries.**



Back-up Slides



Five Blanket Concepts Originally Evaluated

Cross-section of the Flibe Blanket Box (Front View)

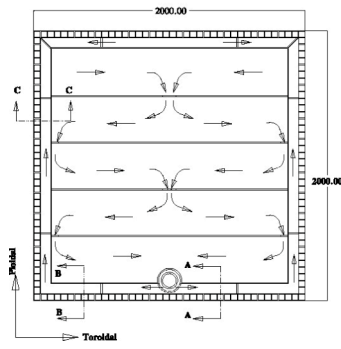

Cross Section of ARIES-CS Outboard Blanket/Shield (One Segment)

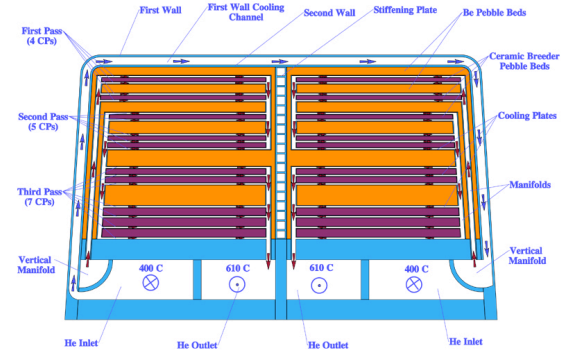
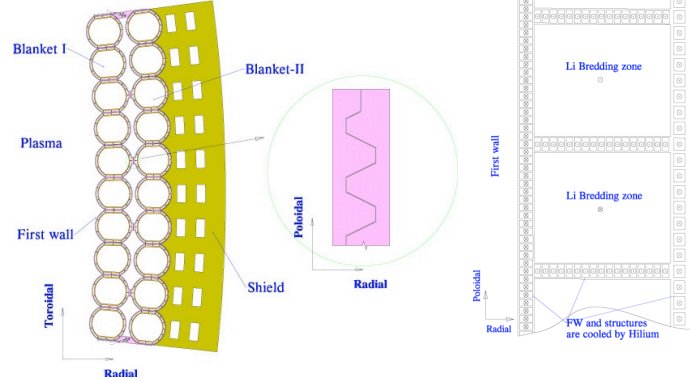

1) Self-cooled flibe with ODS FS

2) Self-cooled Pb-17Li with SiC_f/SiC (ARIES-AT type)

3 & 4) Dual-coolant blankets with He-cooled FS structure and self-cooled Li or Pb-17Li breeder (ARIES-ST type)

5) He-cooled ceramic breeder with FS structure

	<u>Flibe/FS/Be</u>	<u>LiPb/SiC</u>	<u>CB/FS/Be</u>	<u>LiPb/FS</u>	<u>Li/FS</u>
β_{\min}	1.11	1.14	1.29	1.18	1.16
TBR*	1.1	1.1	1.1	1.1	1.1
Energy Multiplication (M_n)	1.2	1.1	1.3	1.15	1.13
Thermal Efficiency (η_{th})	~42-45%	~55-60%	~42%	~42-45%	~42-45%
FW Lifetime (FPY)	6.5	6	4.4	5	7



DC Blanket Parameters for Reference Case

- $R = 7.75 \text{ m}$
- Fusion power = 2364 MW
- Avg. wall load = 2.6 MW/m^2
- Max. wall load = 5.3 MW/m^2
- Avg. plasma $q'' = 0.58 \text{ MW/m}^2$
- Max. plasma $q'' = 0.76 \text{ MW/m}^2$

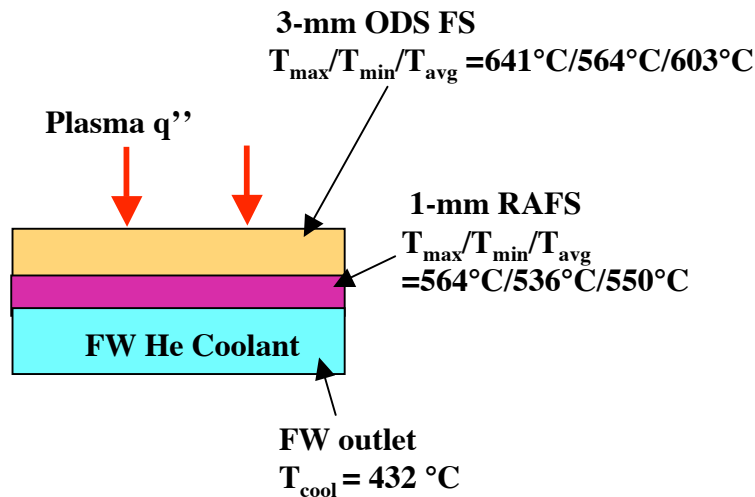

Oct 5, 2006/ARR

Example Module Dimensions for high NWL	2m x 2m x 0.62 m
Tritium Breeding Ratio	1.1
Fusion Thermal Power in Blanket	2450 MW
Pb-17Li Inlet/Outlet Temperatures	448/711°C
Pb-17Li Inlet Pressure	1 MPa
Typical Inner Channel Dimensions	0.26 m x 0.24 m
Thickness of SiC Insulator in Inner Channel	5 mm
Effective SiC Insulator Region Conductivity	200 W/m ² -K
Average Pb-17Li Velocity in Inner Channel	~0.04 m/s
Fusion Thermal Power removed by Pb-17Li	1420 MW
Pb-17Li Total Mass Flow Rate	28,800 kg/s
Pb-17Li Pressure Drop/ Pumping Power	~ 1 kPa/ ~ 20 kW
Maximum Pb-17Li/FS Temperature	458°C
He Inlet/Outlet Temperatures	369/441°C
He Inlet Pressure	10 MPa
Typical FW Channel Dimensions (poloidal x radial)	2 cm x 3 cm
He Velocity in First Wall Channel	49.1 m/s
Total Blanket He Pressure Drop / Pumping Power	0.23 MPa / 132 MW
Fusion Thermal Power Removed by He	1030 MW
Friction Thermal Power Removed by He	119 MW
Total Mass Flow Rate of Blkt He	3222 kg/s
Maximum Local ODS/RAFS Temperature at FW	641/564°C
Radially Avg. ODS/RAFS Temp. at T_{\max} Location	602/550°C
Max. ODS/RAFS Pressure+Thermal Stresses (plane strain)	~667/~390MPa

Divertor Parameters for Reference Case

- $R = 7.75 \text{ m}$
- Fusion power = 2364 MW
- Max. wall load = 5.3 MW/m²
- All alpha loss power on divertor
- Divertor coverage = 0.15
- Max. divertor $q'' = 10 \text{ MW/m}^2$

Divertor T-Tube Dimensions	9 cm (tor.) x 1.6 cm (pol.)
He Inlet Temperature	578°C
He Outlet Temperature	711°C
He Inlet Pressure	10 MPa
FW Channel Dimension	0.5 mm
He Jet Velocity	200 m/s
Average Jet Flow h	~ 17,000 W/m²-K
He Pressure Drop	0.45 MPa
Fusion Thermal Power in Divert.	201 MW
Divertor He Friction Power	~29 MW
Total Mass Flow Rate	334 kg/s
Pumping Power	~32 MW
Maximum W Alloy Temperature	<1300°C
Max.Primary+Secondary Stresses	<370 MPa



EM Load Analysis

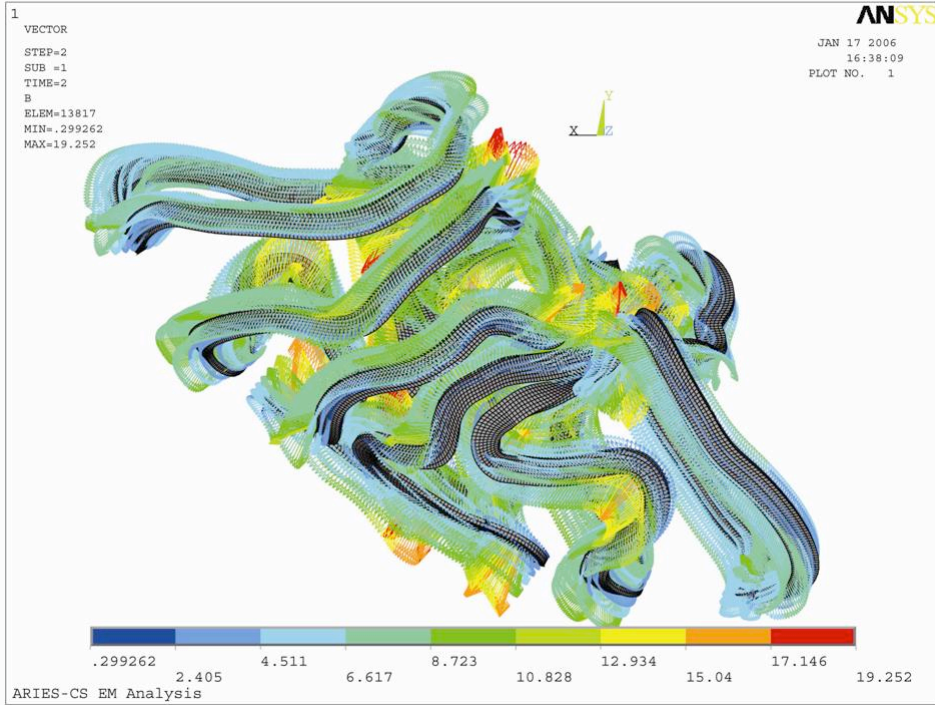
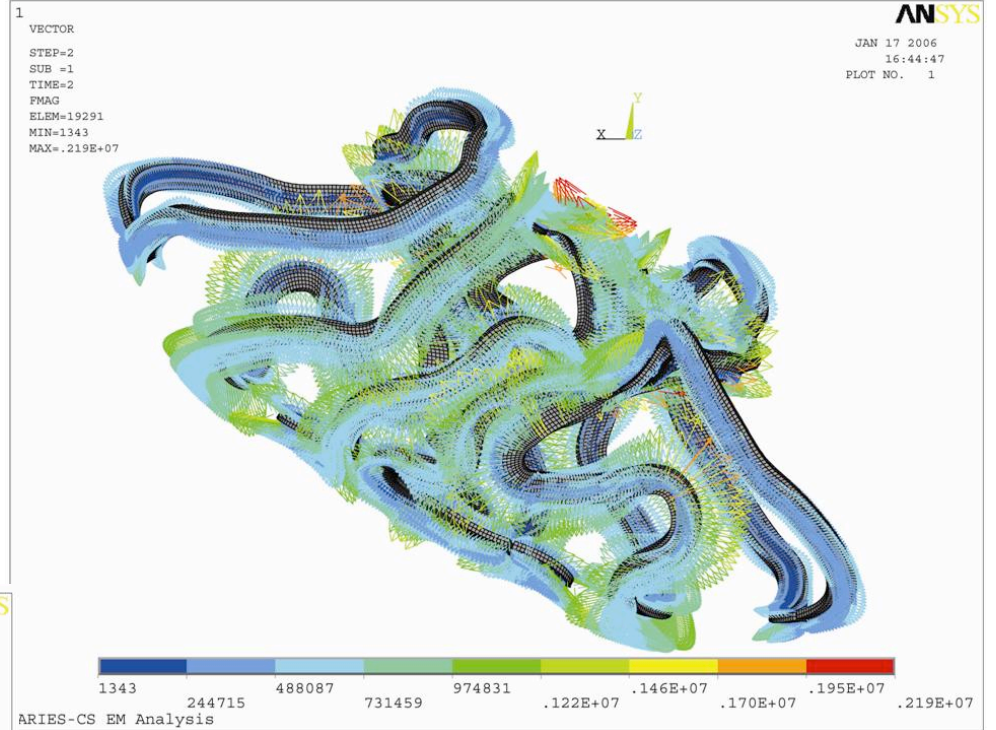

Net Forces in the Modular Coils

	F_r , MN	F_θ , MN	F_z , MN
M1L	-58.5	377.2	22.6
M1R	-58.5	-377.2	-22.6
M2L	-257.3	178.5	-150.7
M2R	-257.3	-178.5	150.7
M3L	143.2	51.1	-141.7
M3R	143.2	-51.1	141.7
Sum of all 6 coils	-345.2	0	0



Inventory of He in W Based on Example α -Particle Implantation Case

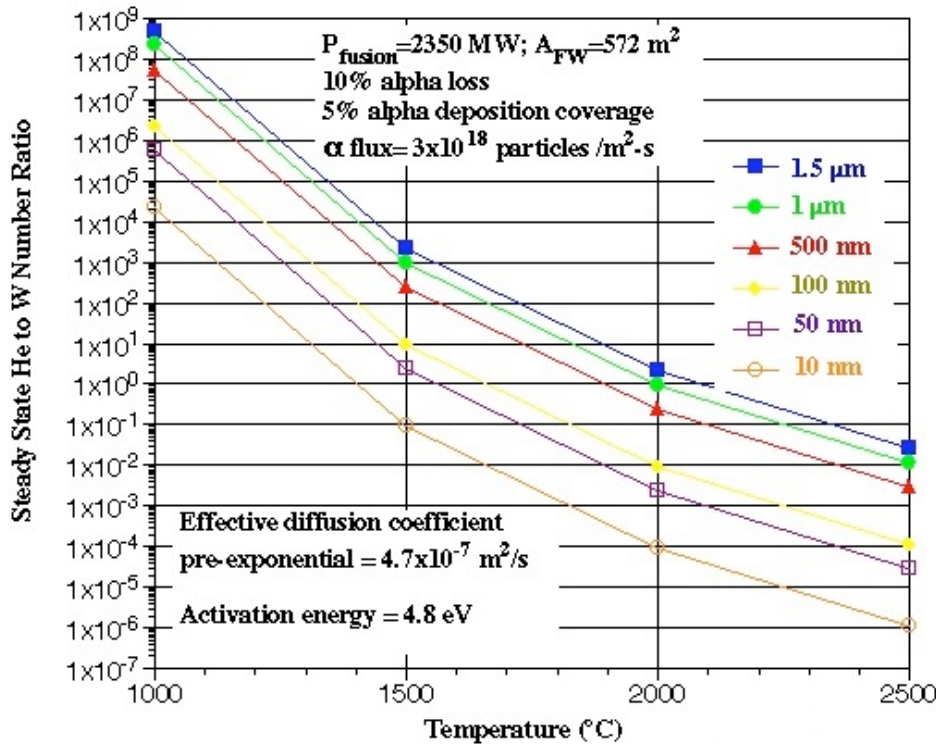

- Simple effective diffusion analysis for different characteristic diffusion dimensions for an activation energy of $\sim 4.8 \text{ eV}$ (vacancy dissociation)
- Not clear what is the max. He conc. limit in W to avoid exfoliation (perhaps $\sim 0.15 \text{ at.}\%$)
- High W temperature needed in this case
- Shorter diffusion dimensions help, perhaps a nanostructured porous W (PPI)
- e.g. 50-100 nm at $\sim 1800^\circ\text{C}$ or higher

- An interesting question is whether at a high W operating temperature ($> \sim 1400^\circ\text{C}$), some annealing of the defects might help the tritium release.
- This is a key issue for a CS which needs to be further studied to make sure that a credible solution exists both in terms of the alpha physics, the selection of armor material, and better characterization of the He behavior under prototypic conditions.

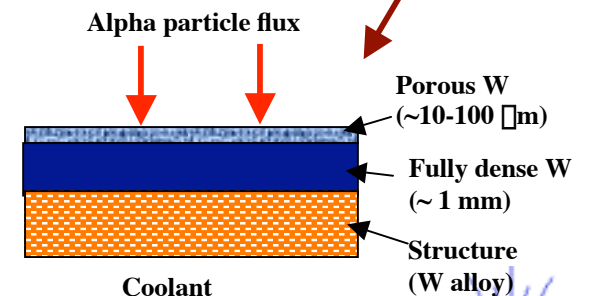

Manufacturing Porous W with Nano-Microstructure (PPI)

- Plasma technology can produce tungsten nanometer powders.
 - When tungsten precursors are injected into the plasma flame, the materials are heated, melted, vaporized and the chemical reaction is induced in the vapor phase. The vapor phase is quenched rapidly to solid phase yielding the ultra pure nanosized W powder
 - Nano tungsten powders have been successfully produced by plasma technique and the product is ultra pure with an average particle size of 20-30nm. Production rates of > 10 kg/hr are feasible.
- Process applicable to molybdenum, rhenium, tungsten carbide, molybdenum carbide and other materials.
- The next step is to utilize such a powder in the Vacuum Plasma Spray process to manufacture porous W (~10-20% porosity) with characteristic microstructure dimension of ~50 nm .

TEM images of tungsten nanopowder, p/n# S05-15 (from PPI)

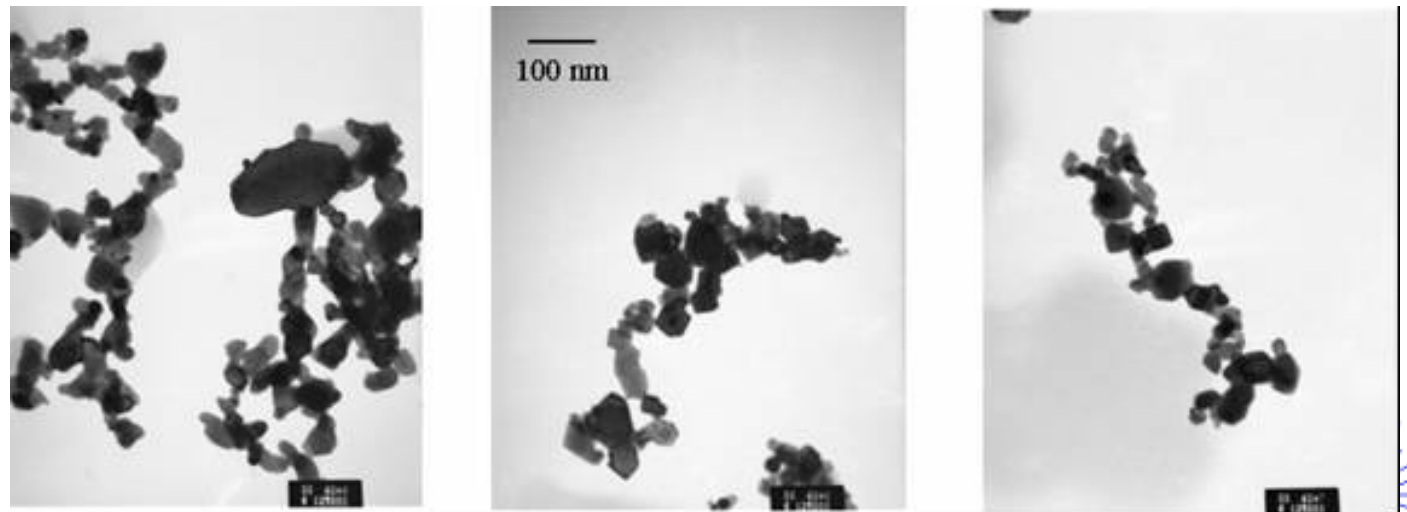

Beyond Design Basis Accident Scenario

- To analyze this accident with MELCOR, a heat transport system (HTS) vault and Brayton cycle volumes were added to the ARIES-CS MELCOR model, with a rupture disk between the cryostat and HTS vault that opens at 3 atm.
- The characteristics of the HTS vault are (based on ITER EDA vault):
 - Volume of 39,240 m³
 - Leak rate of one volume per day for 400 Pa overpressure, with the leak rate scaling as the square root of overpressure
 - HVAC system gives one volume exchange per day, but automatically isolates from the vault when the vault pressure exceeds 1.2 atm
- Brayton cycle volume was scaled from fission reactor by power to be 295 m³ (including secondary side of heat exchangers)



Resulting Power Plants Have Similar Size as Advanced Tokamak Designs

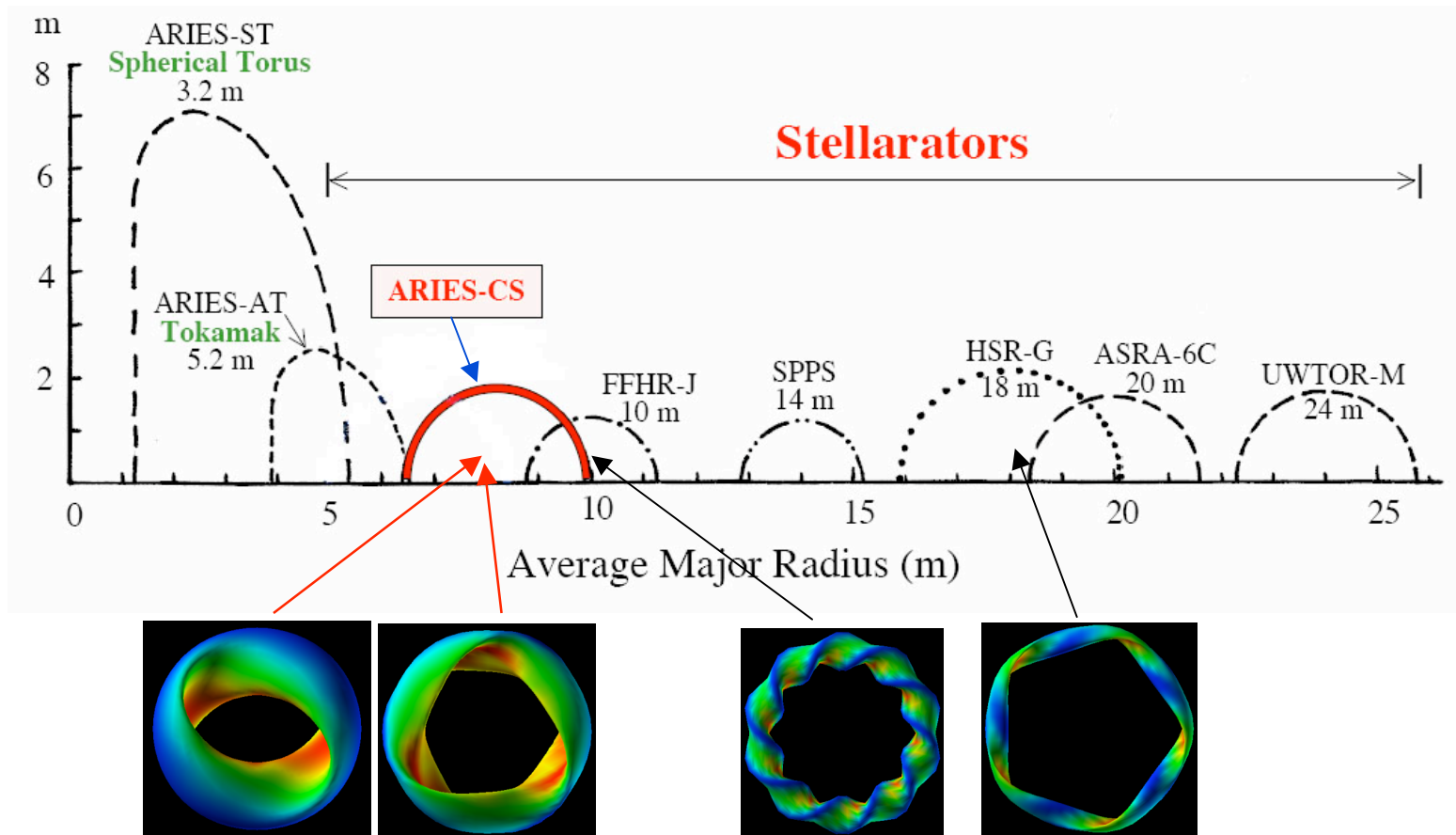

- Design process includes complex interaction of physics/engineering constraints.



Numerical Verification of Divertor Performance

- Numerous analyses (2- & 3-D) have been performed using FLUENT (6.1). The results indicate that:
 - Maximum temperatures at nominal design and operating conditions are consistent with constraints dictated by material properties
 - Sensitivity studies indicate that the proposed divertor design is “Robust” with respect to changes in geometry due to manufacturing tolerances, and/or maldistribution of flow among divertor elements

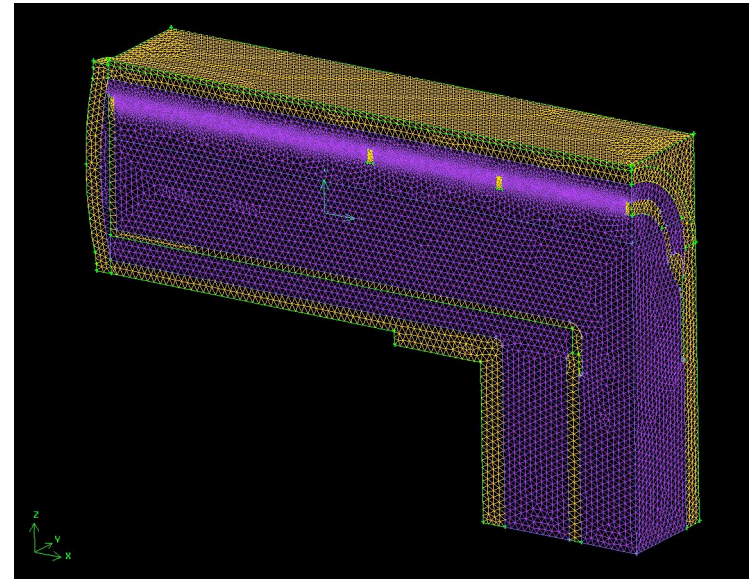

	Max Tile T (K)	Max T (K) Tube/Tile Interface	ΔP (Pa)
3D Reference (V1) (slot width=0.5mm, jet-wall spacing=1.25mm)	1699	1523	1.06×10^5
V2 (slot width=0.4mm)	1621	1452	1.67×10^5
V3 (slot width=0.6mm)	1720	1545	0.86×10^5
V4 (jet-wall spacing =1.0mm)	1728	1557	0.89×10^5
V5 (jet-wall spacing= 1.5mm)	1716	1545	0.90×10^5

Example 3D parametric study of effect of slot width and jet-wall spacing
(All use std. k- ϵ w/wall enhancement)

