

ISOMETRIC VIEW

DATUM "A" = PLANE THRU "XY"  
 DATUM "B" = PLANE THRU "XZ"  
 DATUM "C" = PLANE THRU "YZ"

**Rev 2-a: ECN-4972 (RFD-12-002R1) approved substitution of Schedule 10 for Schedule 40 piping – Applicable to All 3 VVSAs.**

**Rev 2-b: ECN-5113 (RFD-12-009) authorized leaving holes "as is", but utilizing MDC bolt hardware kit 190045 – Applicable to All 3 VVSAs.**

**Rev 2-c: ECN-5115 (RFD-12-016) approved modifying weld to fillet weldsto the opposite side of the groove weld and to relax the flatness requirement to 0.050" if opposing side fillets applied – Applicable to All 3 VVSAs.**

**Rev 2-d: ECN-5082 (RFD-12-014) eliminated weld relief originally requested by MTM since they elected to pursue other means of leak checking. Grooves no longer required. – Applicable to All 3 VVSAs.**

**Rev 2-e: ECN-5021 (RFD-12-017) approved alternate methods for welding the port extensions to the VVSA (See ECN-5021 for details). – Only applicable to VVSA #3 – VVSA #1 and #2 covered by NCR 19464.**

**ECN-5067 implements RFD-12-009 which approved making mounting holes in bosses true position to Datum B and Datum C only => removed true position callout for Datum A. (Rev 2-f)**

QTY	QTY	QTY	QTY	QTY	QTY	QTY	QTY	QTY	QTY
34	-57	SILVER PLATED, 12-POINT BOLTS, .50-20UNF, 2.00 LG	INCO 718	ASTM A1014	57				
218	-56	WASHER, Ø0.531 ID X Ø1.062 OD X .095 THICK	A286	ANSI 18.22.1	56				
184	-55	NUT, 0.50 X 20UNF	GRADE 8	ASTM A194	55				
2	SE121-095	VACUUM VESSEL SEAL DETAIL			54				
1	-53	O-RING, METAL, HELICOFLEX TYPE HN9	HELICOFLEX PO BOX 9889 COLUMBIA, SC 29209 PHONE # 1-800-233-1722		53				
1	-52	O-RING, METAL, HELICOFLEX TYPE HN9			52				
2	-51	CLEVIS BOSS "D"	UNS N06625		51				
2	-50	CLEVIS BOSS "C"	UNS N06625		50				
2	-49	CLEVIS BOSS "B"	UNS N06625		49				
2	-48	CLEVIS BOSS "A"	UNS N06625		48				
40	-47	BUTTON HD CAP SCREW #8-32UNC X .25 LG	300 SERIES SST		47				
2	-46	O-RING, .211 OD, 95.51 LG +0.0/-0.25	VITON		46				
2	-45	O-RING, .211 OD, 90.93 LG +0.0/-0.25	VITON		45				
2	-44	O-RING, .211 OD, 117.82 LG +0.0/-0.25	VITON		44				
2	-43	O-RING, .211 OD, 113.23 LG +0.0/-0.25	VITON		43				
2	-42	O-RING, .211 OD, 63.12 LG +0.0/-0.25	VITON		42				
2	-41	O-RING, .211 OD, 53.53 LG +0.0/-0.25	VITON		41				

REV	DESCRIPTION	BY	DATE	CHK	DEPT	DATE	PE	REQ	DATE	ORNL	DOE	DATE
1	REVISED PER ECN-4945 & ECN-4961	GHJ	2/28/03	MJC								
2	REVISED PER ECN-4933	MJC	11/22/04	PLG								

- NOTES:
- INTERPRET DIMENSIONS AND TOLERANCES PER ANSI Y14.5M.
  - DIMENSION ARE IN INCHES.
  - FABRICATION, INSPECTION, TESTING SHALL BE PERFORMED IN ACCORDANCE WITH SPECIFICATION NCSX-CSPEC-121-02 AND STATEMENT OF WORK NCSX-SOW-121-03.
  - PROFILE TOLERANCE ON OUTER VACUUM SURFACE IS BILATERAL, i.e. 0.1875 EITHER SIDE OF REFERENCE SURFACE.
  - THE MINIMUM THICKNESS AFTER FORMING SHALL BE .338. THINNING BELOW THE STOCK THICKNESS SHALL NOT OCCUR OVER MORE THAN 10% OF THE TOTAL POLOIDAL CIRCUMFERENCE OF ANY CROSS-SECTION
  - PORT LENGTH DIMENSIONS SHOWN ARE FINAL DIMENSIONS AFTER PORTS ARE CUT OFF AND REASSEMBLED. TOLERANCE OF LENGTH IS  $\pm 0.125$ . INSPECTED DIMENSION SHALL BE AS SHOWN ON DRAWING PLUS 0.50".
  - PORT 4 DIMENSIONS SHOWN ARE INSPECTED DIMENSIONS.
  - SUPPLIED BY PPPL
  - ALL DIMENSIONS TO BE MET AT DWG SEI20-002.
  - REDUCING NIPPLES ARE OPTIONAL. BLANK FLANGES MAY BE SUBSTITUTED.
  - A TOLERANCE DEVIATION OF  $+ 3/16 - 7/16$  AT THE PERIMETER OF PORT 4 AND PORT 12 WHICH RETURNS TO THE NOMINAL SHELL PROFILE WITHIN 8" OF THE PERIMETER OF THE PORT, WILL BE ACCEPTED.
  - A TOLERANCE DEVIATION OF  $+ 3/16 - 5/16$  AT THE PERIMETER OF THE ROUND PORTS, NB PORT, AND THE DOME PORT WHICH RETURNS TO THE NOMINAL SHELL PROFILE WITHIN 8" OF THE PERIMETER OF THE PORT, WILL BE ACCEPTED.

QTY	QTY	QTY	QTY	QTY	QTY	QTY	QTY	QTY	QTY
1	191094	GASKET, COPPER 10.00 ID, PKG 10 REF 12 FLG							40
1	191019	GASKET, COPPER 8.01 ID, PKG 10 REF 10 FLG							39
1	191017	GASKET, COPPER 6.01 ID, PKG 10 REF 8.00 FLG							38
1	191013	GASKET, COPPER 4.01 ID, PKG 10 REF 6.00 FLG							37
1	191011	GASKET, COPPER 3.01 ID, PKG 10 REF 4.63 FLG							36
10	190059	BOLT SET 8.00 OD & 10.00 OD FLG 12PT BOLT, SILVER PLTG, PKG 25							35
12	190058	BOLT SET 4.63 OD & 6.00 OD FLG 12PT BOLT, SILVER PLTG, PKG 25							34
4	190165	HEX HD, .312-24UNC, 2.00 LG PKG 36 WITH NUTS & FLAT WASHERS							33
184	-32	SILVER PLATED, 12-POINT BOLTS, .50-20UNF, 3.5 LG	GRADE 660	ASTM A 453	32				
2	FA10000133	REDUCING NIPPLE 10.00 TO 1.33			31				
4	FA08000133	REDUCING NIPPLE 8.00 TO 1.33			30				
10	FA06000133	REDUCING NIPPLE 6.00 TO 1.33			29				
2	FA04620133	REDUCING NIPPLE 4.63 TO 1.33			28				
4	130093	CONFLAT, 12.00 OD, TAPPED			26				
2	130033	CONFLAT, 10.00 OD, TAPPED			25				
4	130031	CONFLAT, 8.00 OD, TAPPED			24				
10	130026	CONFLAT, 6.00 OD, TAPPED			23				
2	130022	CONFLAT, 4.63 OD TAPPED			22				
2	SE121-013	VACUUM VESSEL FLANGE DETAIL			21				
2	-20	ELLIPTICAL HD, 18.00 OD X .375 WALL	BRIGHTON TRU-EDGE HEADS 4955 SPRING GROVE AVE CINCINNATI, OHIO 45232 PHONE # 800 543-1644		20				
AR	-19	TUBE, 10.00 X .250 WALL	UNS 06625		19				
AR	-18	TUBE, 8.00 X .188 WALL	UNS 06625		18				
AR	-17	TUBE, 6.00 X .188 WALL	UNS 06625		17				
AR	-16	PIPE, 2.5 SCH 40	UNS 06625		16				
AR	-15	PIPE, 3.5 SCH 40	UNS 06625		15				
AR	-14	PLATE, .500 THK	UNS 06625		14				
AR	-13	PLATE, .375 THK	UNS 06625		13				
4	SE122-112	VACUUM VESSEL 12 IN COVER TEST FLANGE DETAIL			12				
2	SE121-102	VACUUM VESSEL BLANK OFF COVER SEAL WELDMNT			11				
1	SE122-172	VACUUM VESSEL NB PORT COVER TEST FLANGE DETAIL			10				
1	SE122-173	VACUUM VESSEL PORT NB SEAL RETAINER DETAIL			9				
1	SE122-072	VACUUM VESSEL PORT NB FLANGE DETAIL			8				
2	SE122-149	VACUUM VESSEL PORT 4 COVER TEST FLANGE WELDMNT			7				
2	SE122-057	VACUUM VESSEL PORT 4 SEAL RETAINER DETAIL			6				
2	SE122-049	VACUUM VESSEL PORT 4 FLANGE DETAIL			5				
2	SE122-104	VACUUM VESSEL PORT 12 COVER TEST FLANGE WELDMNT			4				
2	SE122-019	VACUUM VESSEL PORT 12 SEAL RETAINER DETAIL			3				
2	SE122-018	VACUUM VESSEL PORT 12 FLANGE DETAIL			2				
1	-1	VACUUM VESSEL PERIOD INSPECTION AND LEAK CHECK ASSEMBLY			1				

WELDING ENGINEER  
 APPROVED: R. PARSELLS DATE: 6/04

SCALE NOTED	DES. P. L. GORANSON	12/02	UT-BATTELLE	Oak Ridge National Laboratory managed for the DEPARTMENT OF ENERGY under U.S. GOVERNMENT CONTRACT DE-AC05-00OR22725 UT-BATTELLE, LLC - Oak Ridge, Tennessee
FRACTIONS : ± .01	CHK :			
XX DECIMALS : ± .01	PE :			
XXX DECIMALS : ± .005	CR :			
ANGLES : ± 0'15"	PJ :			
BREAK SHARP EDGES 06 MAX	RD :			
FINISH : ± .005 UNLESS OTHERWISE SPECIFIED	PPPL DRFT :			
	DRWG :			
	DRAWING APPROVALS :			
	DATE :			
	VERSION NO. :	5		
	PLANT :	X-10		
	BLDG :	5700		
	FL :	3		
	SHT OF :	19		
	TYPE :	A		
	CLASS :	U		
	REV :	2		
	RELEASE LEVEL :	Fabrication		
	PROJECT NAME :	NATIONAL COMPACT STELLARATOR EXPERIMENT		
		VACUUM VESSEL PERIOD INSPECTION AND LEAK CHECK ASSEMBLY		
		SEI20-004		

**RELEASED FOR FABRICATION / INSTALLATION**  
 PPPL Drafting:

**P** THIS DRAWING PRODUCED ON PRO-ENGINEER

NO REPRESENTATION OR WARRANTY, EXPRESSED OR IMPLIED, IS MADE AS TO THE ACCURACY, COMPLETENESS OR USEFULNESS OF THE INFORMATION OR STATEMENTS CONTAINED IN THESE DRAWINGS, OR THAT THE USE OR DISCLOSURE OF ANY INFORMATION, APPARATUS, METHOD OR PROCESS DISCLOSED IN THESE DRAWINGS MAY NOT INFRINGE PRIVATE RIGHTS OF OTHERS. NO LIABILITY IS ASSUMED WITH RESPECT TO THE USE OF, OR FOR DAMAGES RESULTING FROM THE USE OF, ANY INFORMATION, APPARATUS, METHOD OR PROCESS DISCLOSED IN THESE DRAWINGS. DRAWINGS MADE AVAILABLE FOR INFORMATION TO BIDDER ARE NOT TO BE USED FOR OTHER PURPOSES, AND ARE TO BE RETURNED UPON REQUEST OF THE FORWARDING CONTRACTOR.

FOR NOTES AND PARTS LIST SEE SHEET 1

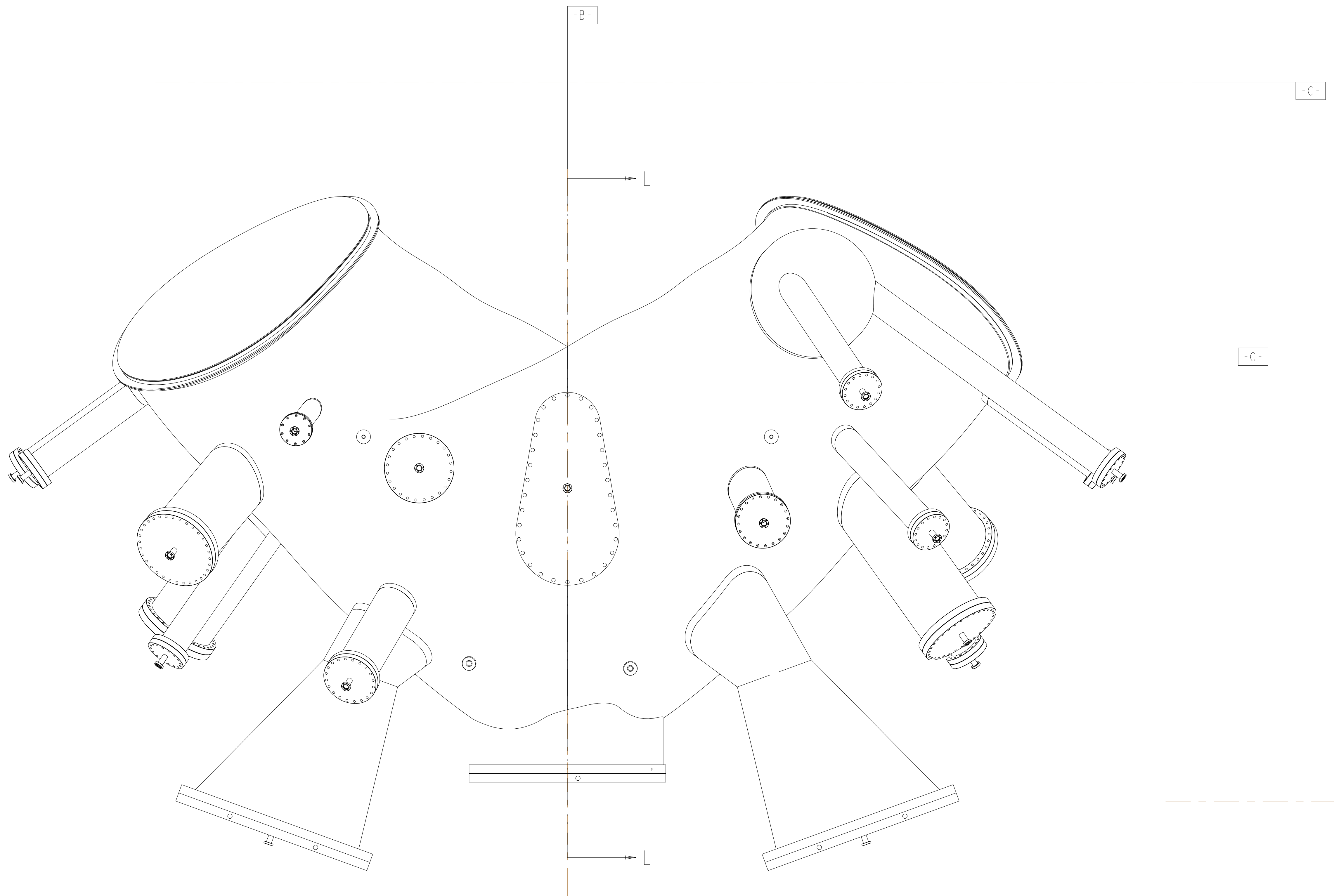

TOP VIEW

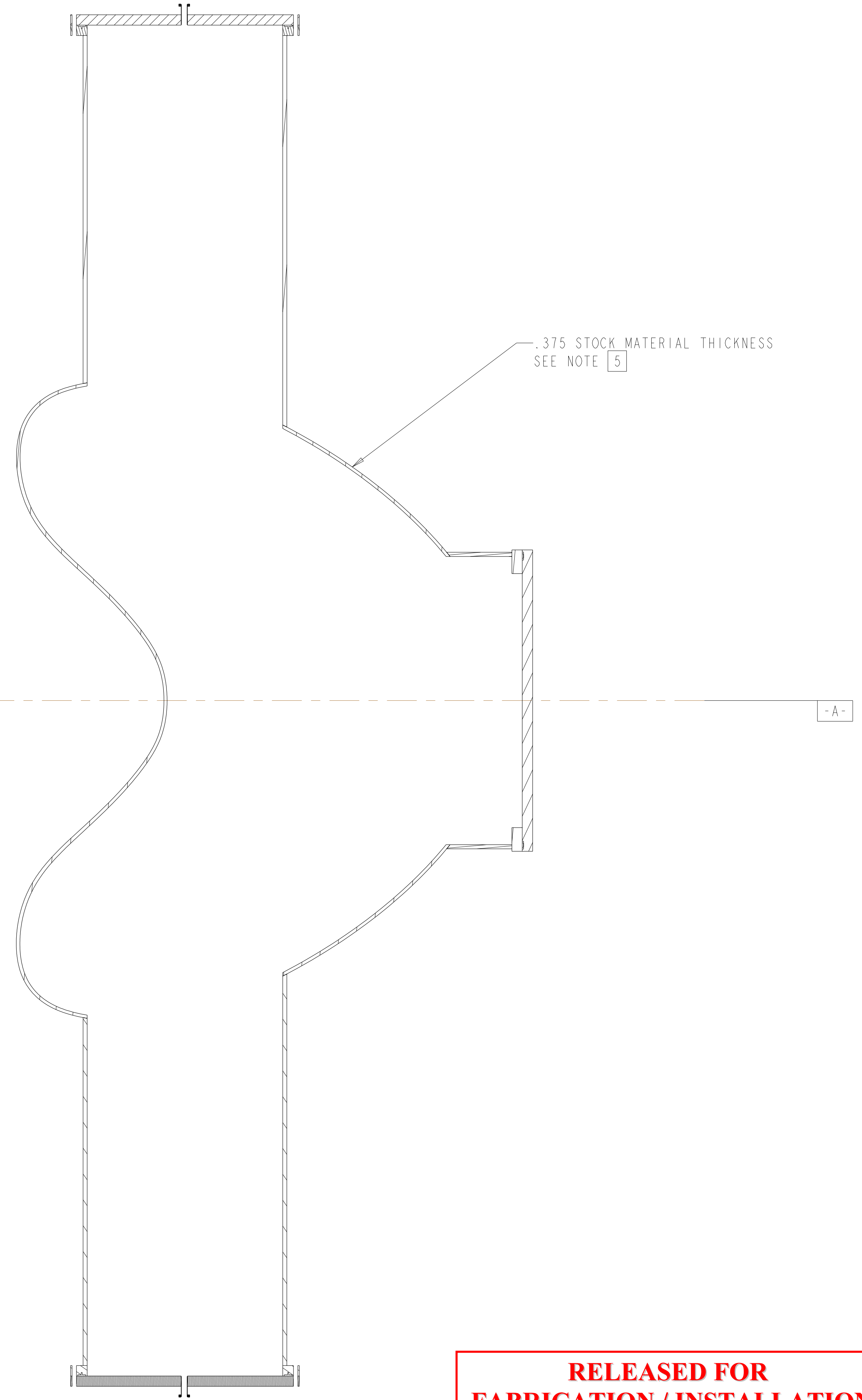

SECTION L-L  
 VESSEL THICKNESS

**RELEASED FOR  
 FABRICATION / INSTALLATION**  
 PPPL Drafting:

Oak Ridge National Laboratory managed for the DEPARTMENT OF ENERGY under U.S. GOVERNMENT contract DE-AC05-00OR22725 UT-BATTELLE, LLC, Oak Ridge, Tennessee PROJECT NAME						
NATIONAL COMPACT STELLERATOR EXPERIMENT VACUUM VESSEL PERIOD INSPECTION AND LEAK CHECK ASSEMBLY						
VERSION NO.	PLANT	BLDG	FL	SHT OF	TYPE	CLASS
5	X-10	5700	3	2 19	A	U
RELEASE LEVEL		SE120-004			REV	
Fabrication					2	

H  
G  
F  
E  
D  
C  
B  
A

FOR NOTES AND PARTS LIST SEE SHEET 1

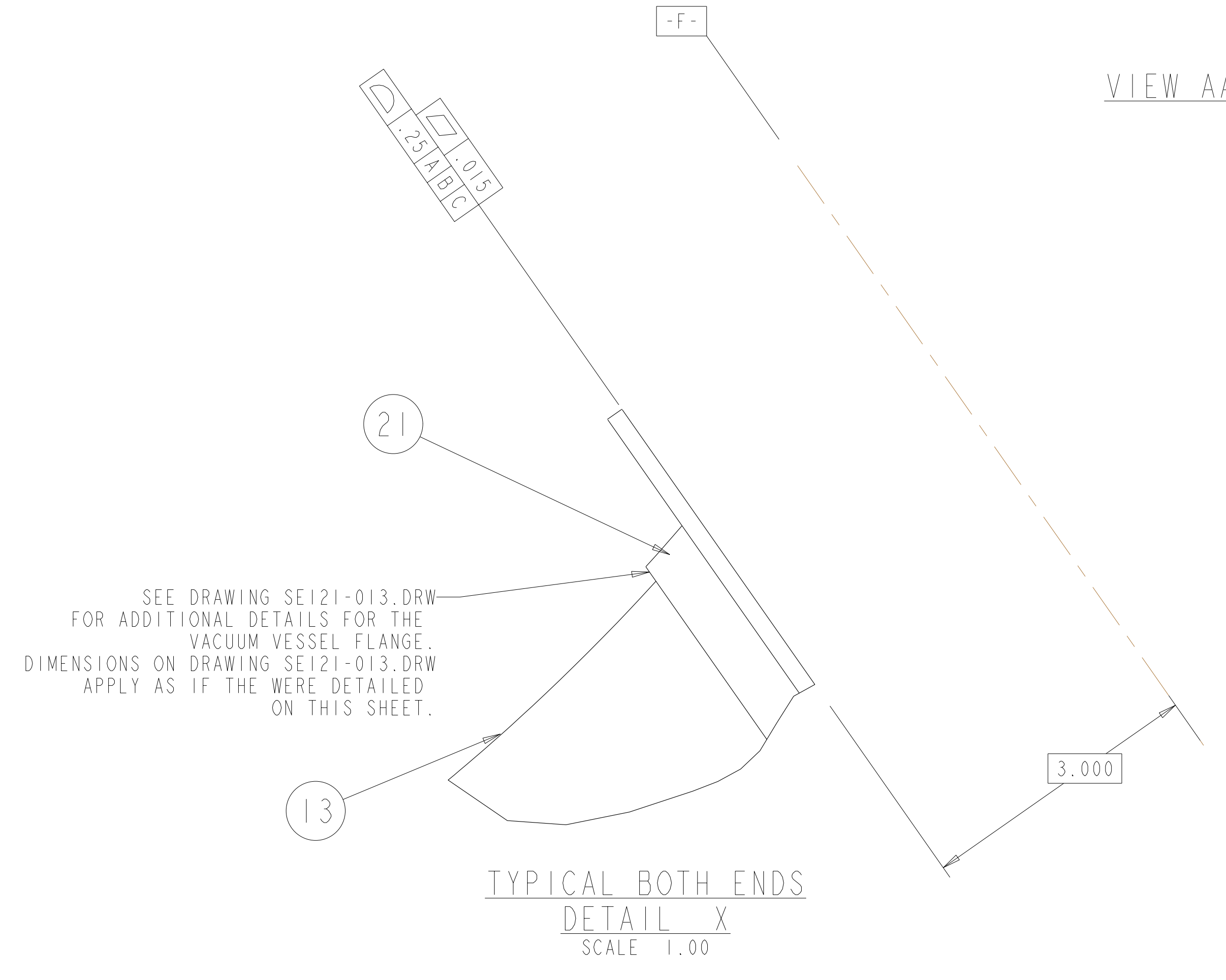
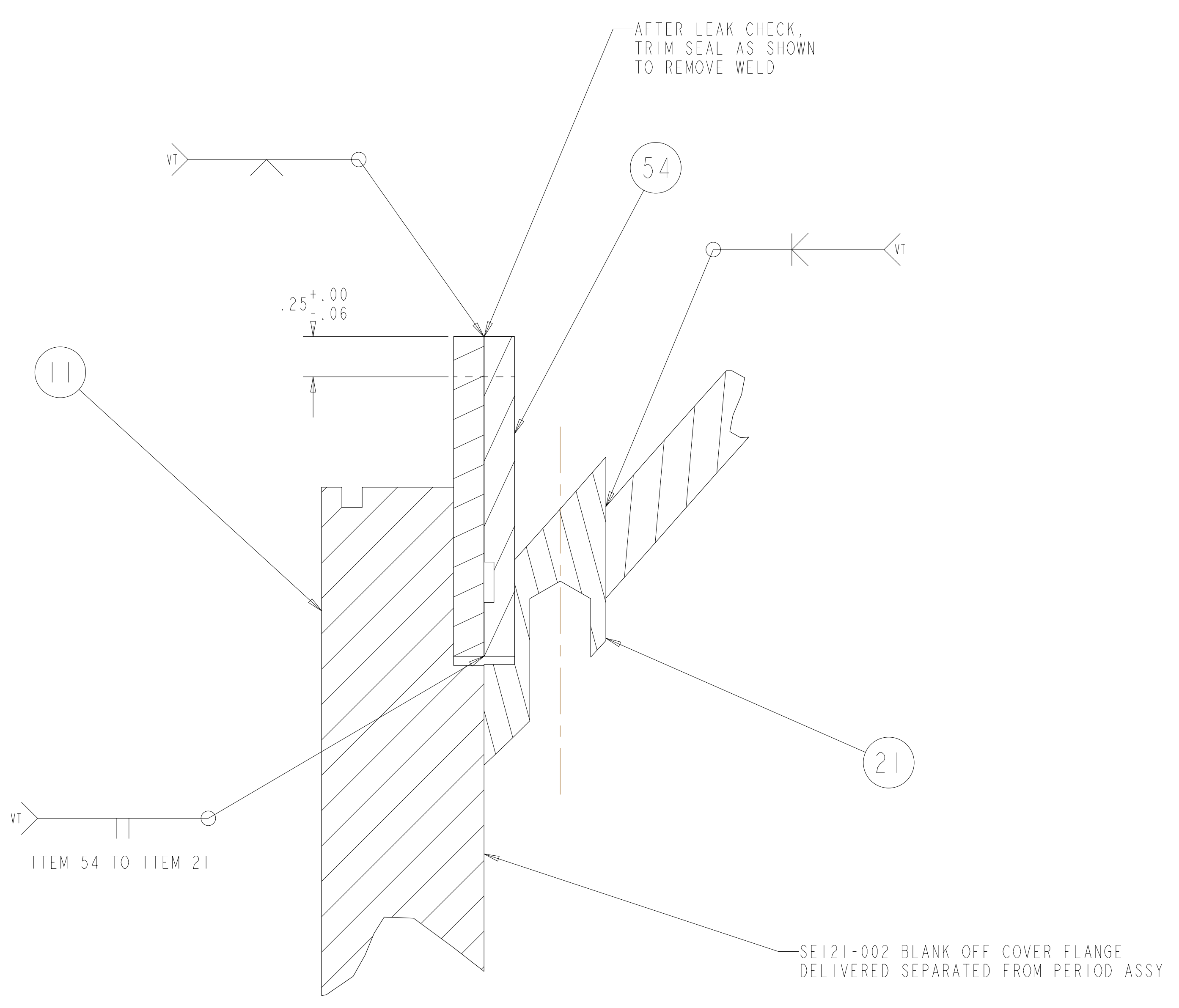
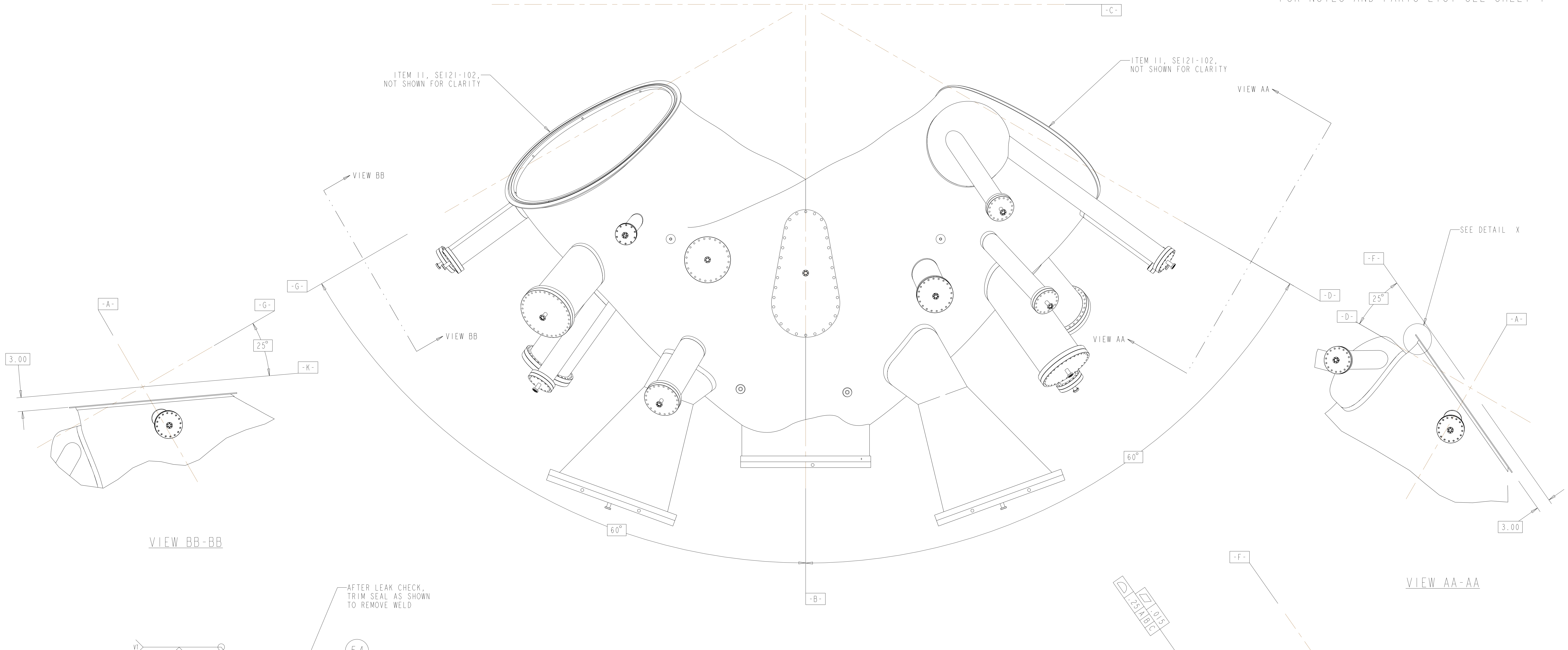

**RELEASED FOR FABRICATION / INSTALLATION**  
 PPPL Drafting:

UT-BATTELLE		Oak Ridge National Laboratory managed for the DEPARTMENT OF ENERGY under U.S. GOVERNMENT contract DE-AC05-00OR22725 UT-BATTELLE, LLC, Oak Ridge, Tennessee					
PROJECT NAME							
NATIONAL COMPACT STELLARATOR EXPERIMENT							
VACUUM VESSEL PERIOD INSPECTION AND LEAK CHECK ASSEMBLY							
VERSION NO.	PLANT	BLDG	FL	SHT OF	TYPE	CLASS	
5	X-10	5700	3	3 19	A	U	
RELEASE LEVEL	Fabrication					SE120-004	REV 2

H  
G  
F  
E  
D  
C  
B  
A

FOR PARTS LIST AND NOTES SEE SHEET 1.

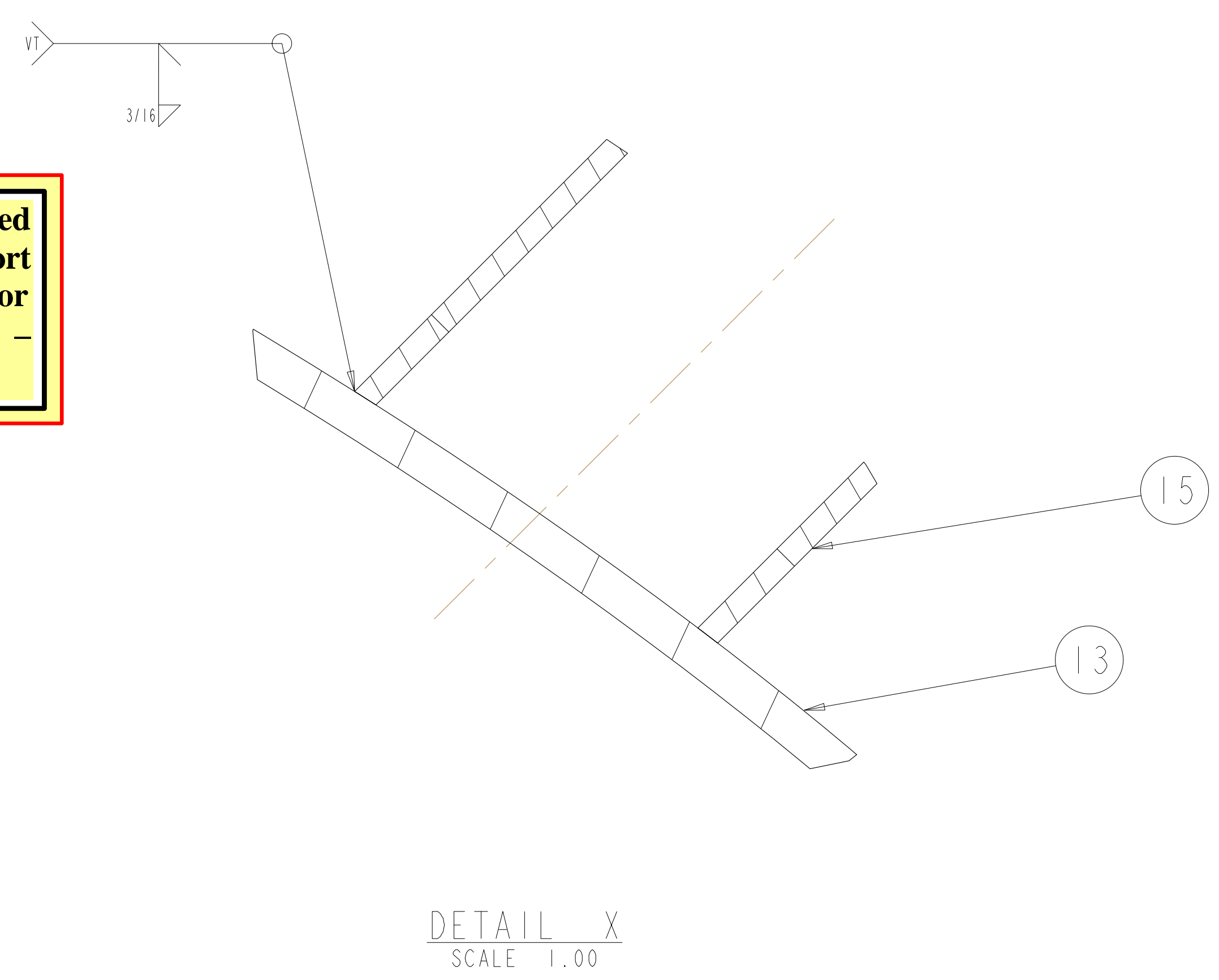
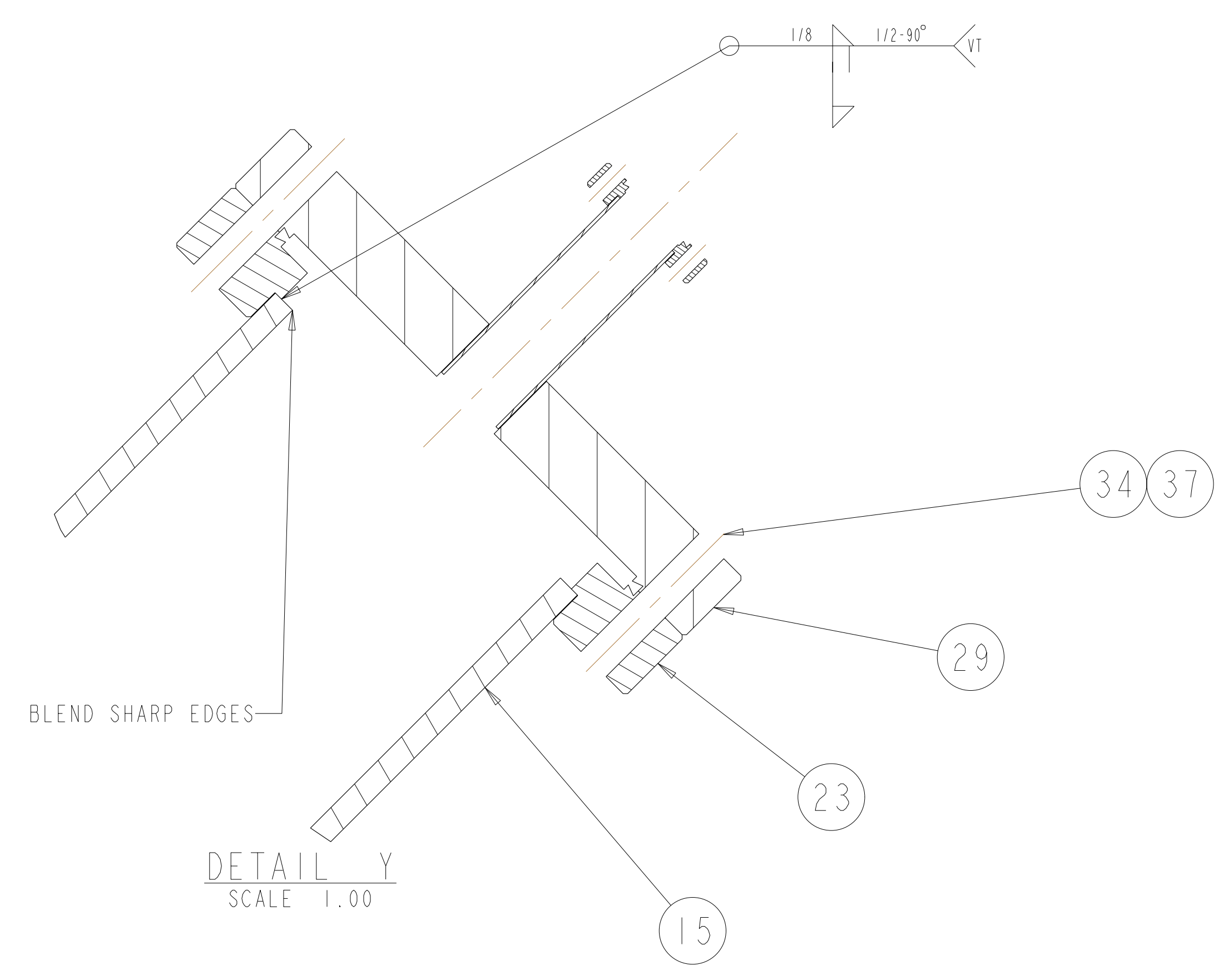
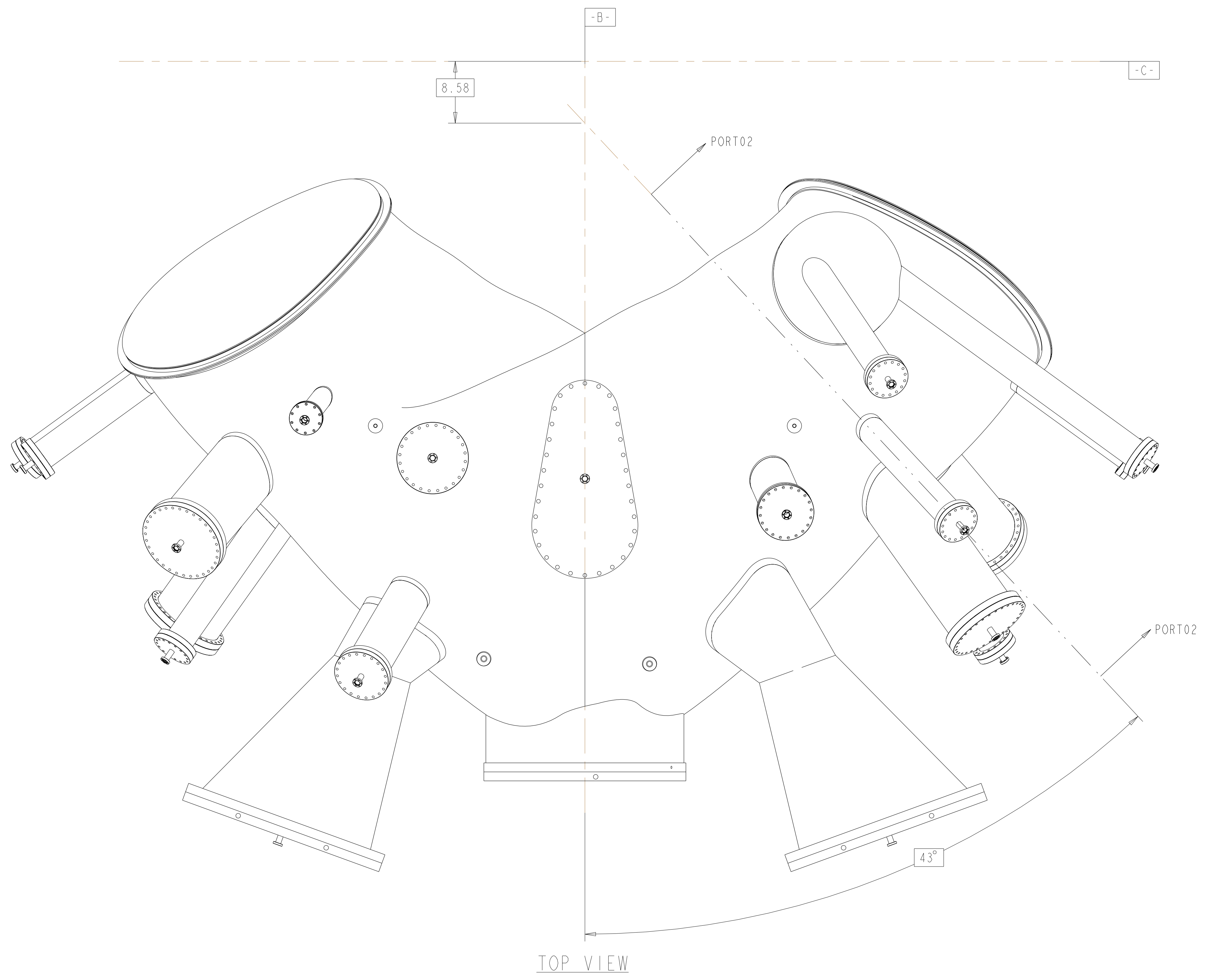

**Rev 2-e: ECN-5021 (RFD-12-017) approved alternate methods for welding the port extensions to the VVSA (See ECN-5021 for details). - Only applicable to VVSA #3 - VVSA #1 and #2 covered by NCR 19464.**

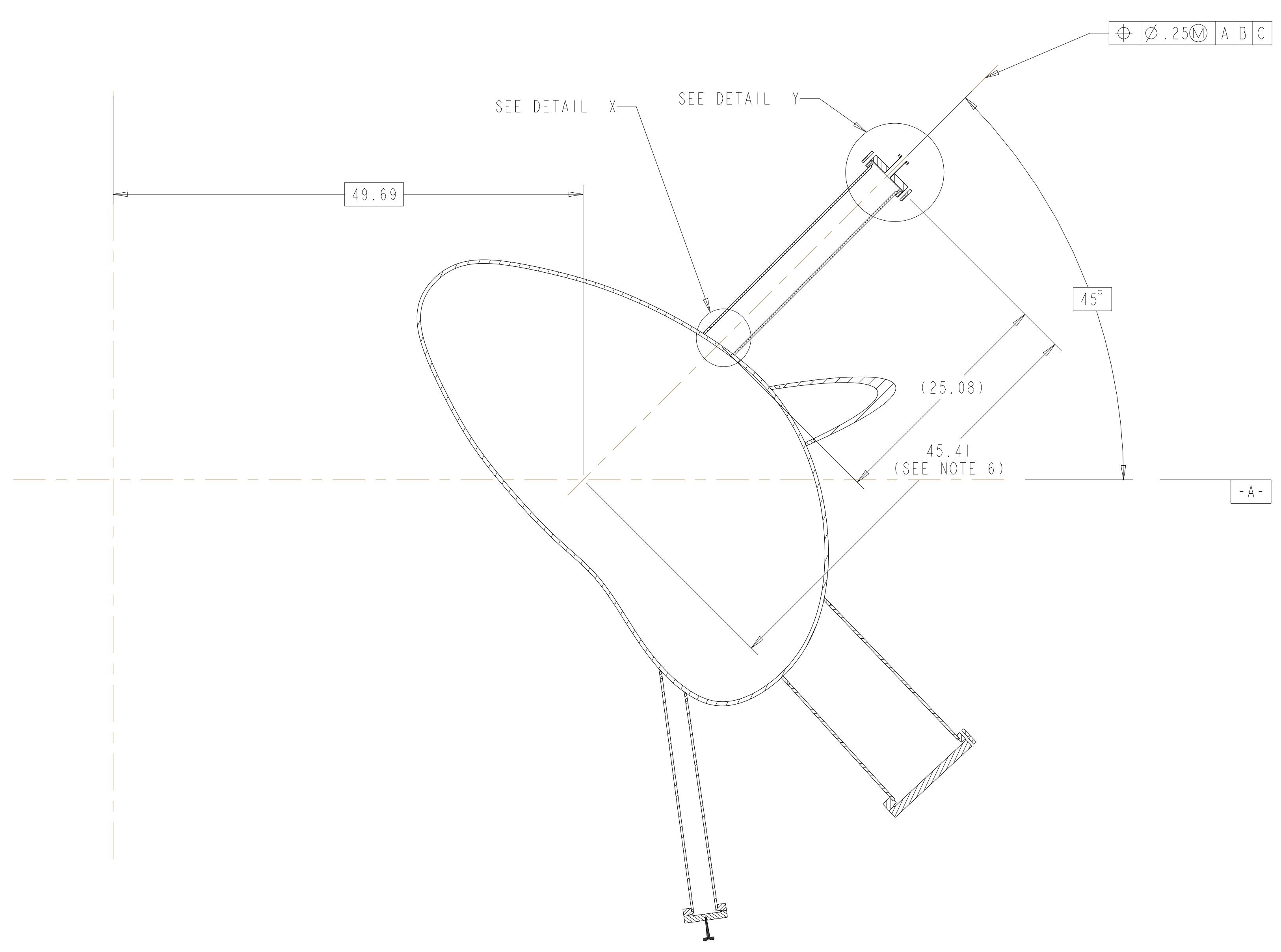

**RELEASED FOR FABRICATION / INSTALLATION**  
 PPPL Drafting:

UT-BATTELLE		Oak Ridge National Laboratory managed for the DEPARTMENT OF ENERGY under U.S. GOVERNMENT contract DE-AC05-00OR22725 UT-BATTELLE, LLC, Oak Ridge, Tennessee					
NATIONAL COMPACT STELLARATOR EXPERIMENT							A
VACUUM VESSEL PERIOD INSPECTION AND LEAK CHECK ASSEMBLY							
VERSION NO.	PLANT	BLDG	FL	SHT OF	TYPE	CLASS	
5	X-10	5700	3	4	19	A	U
RELEASE LEVEL	SE120-004						REV
Fabrication							2

H  
G  
F  
E  
D  
C  
B  
A

FOR PARTS LIST AND NOTES SEE SHEET 1.

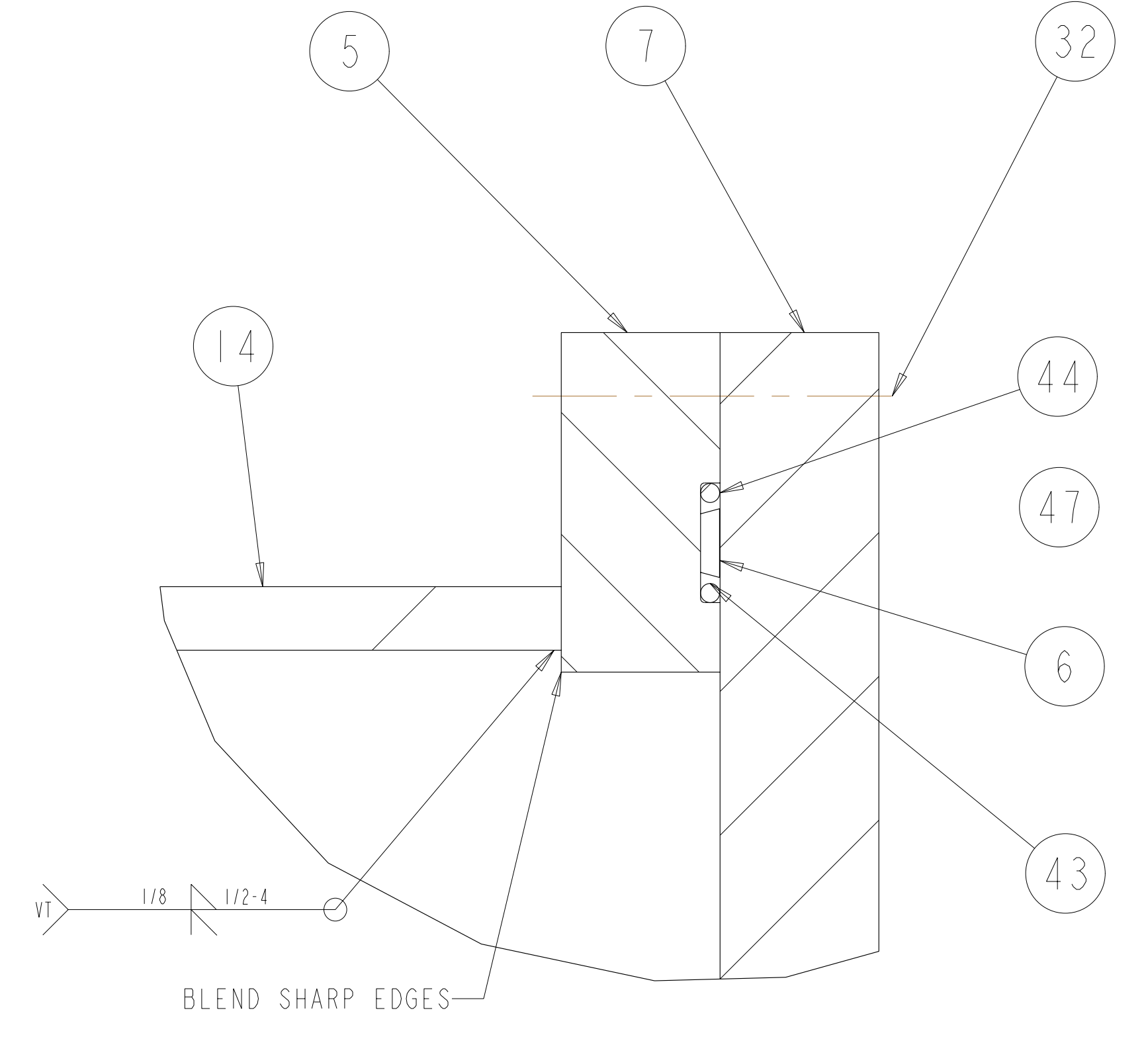
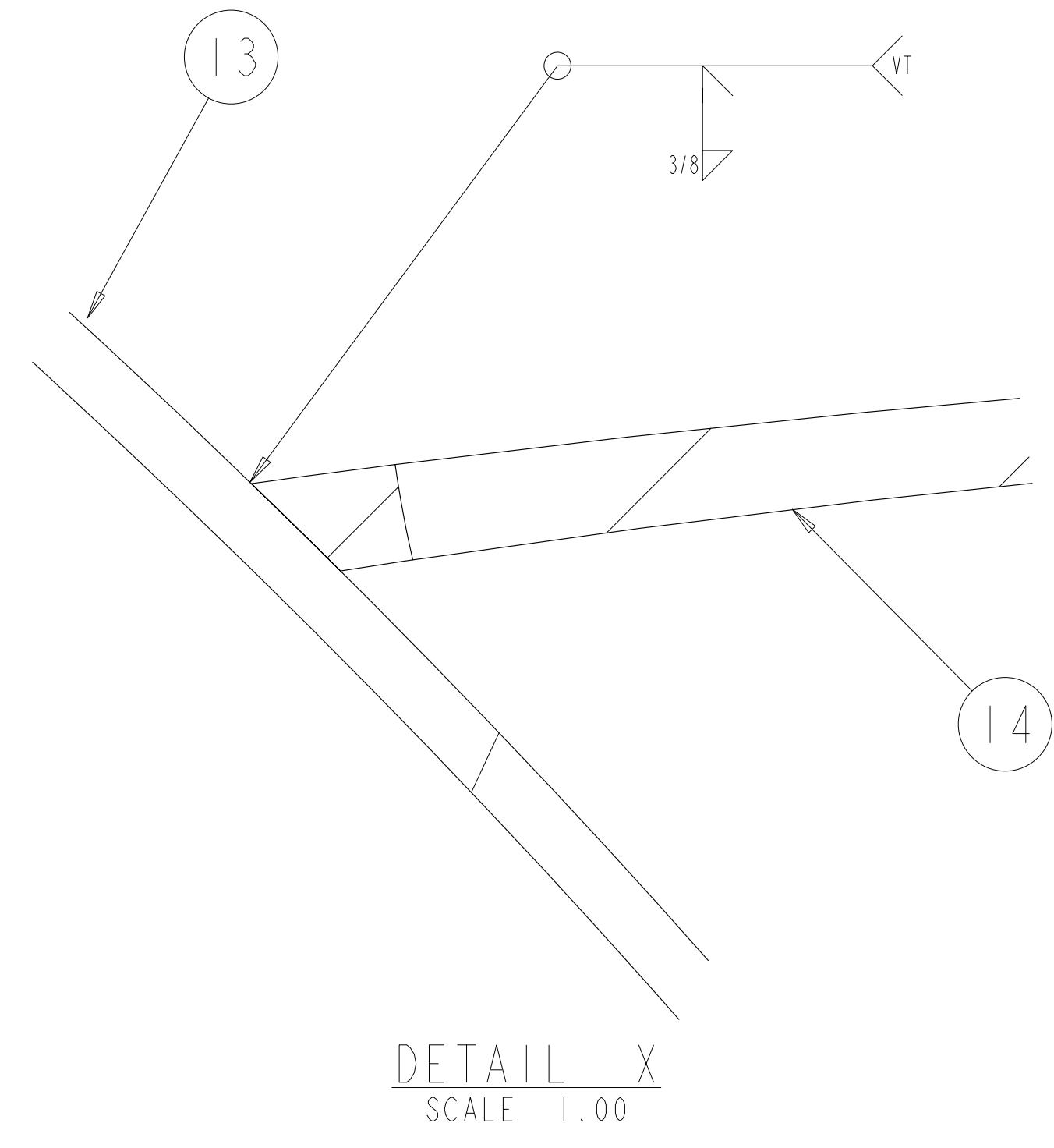
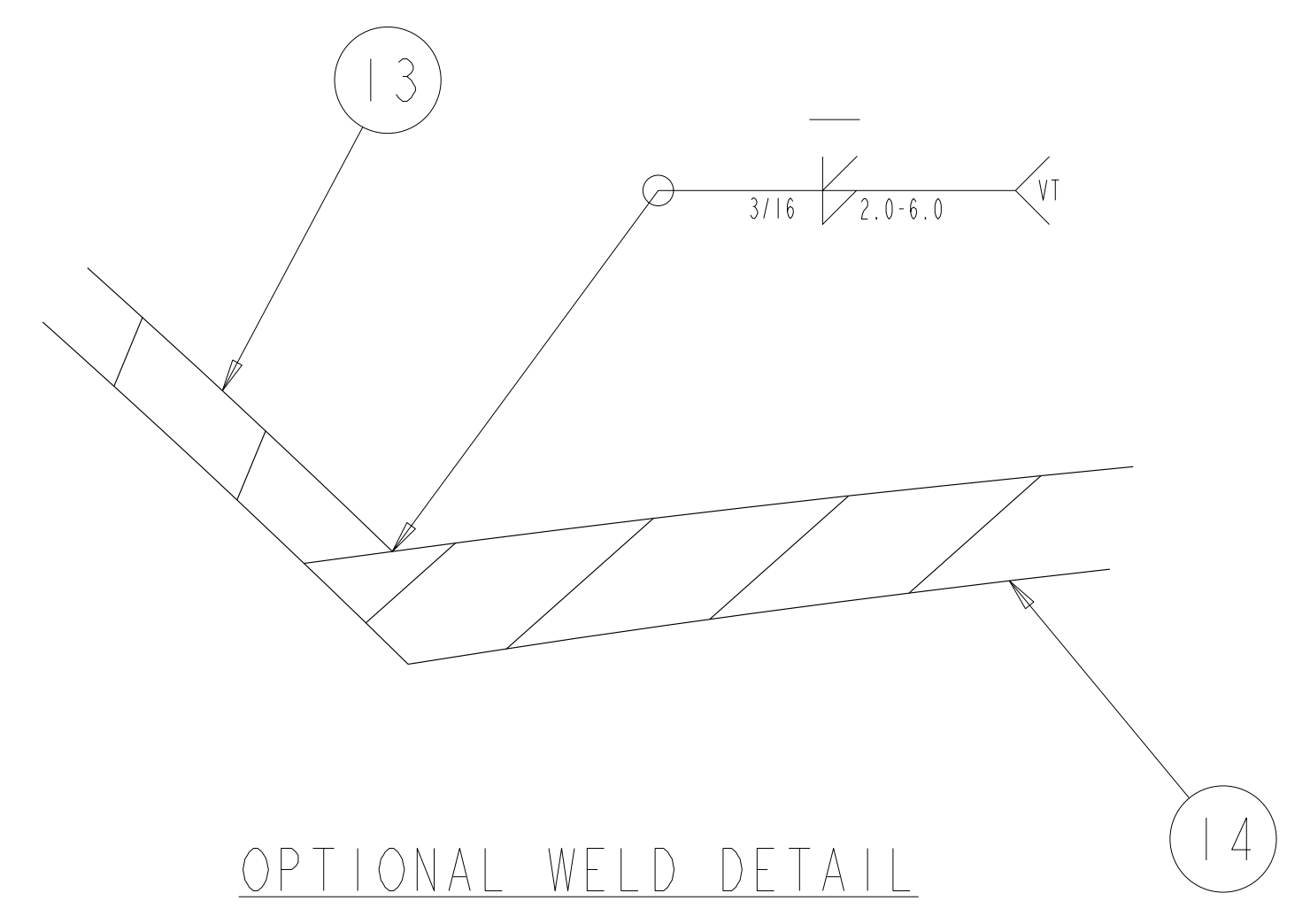
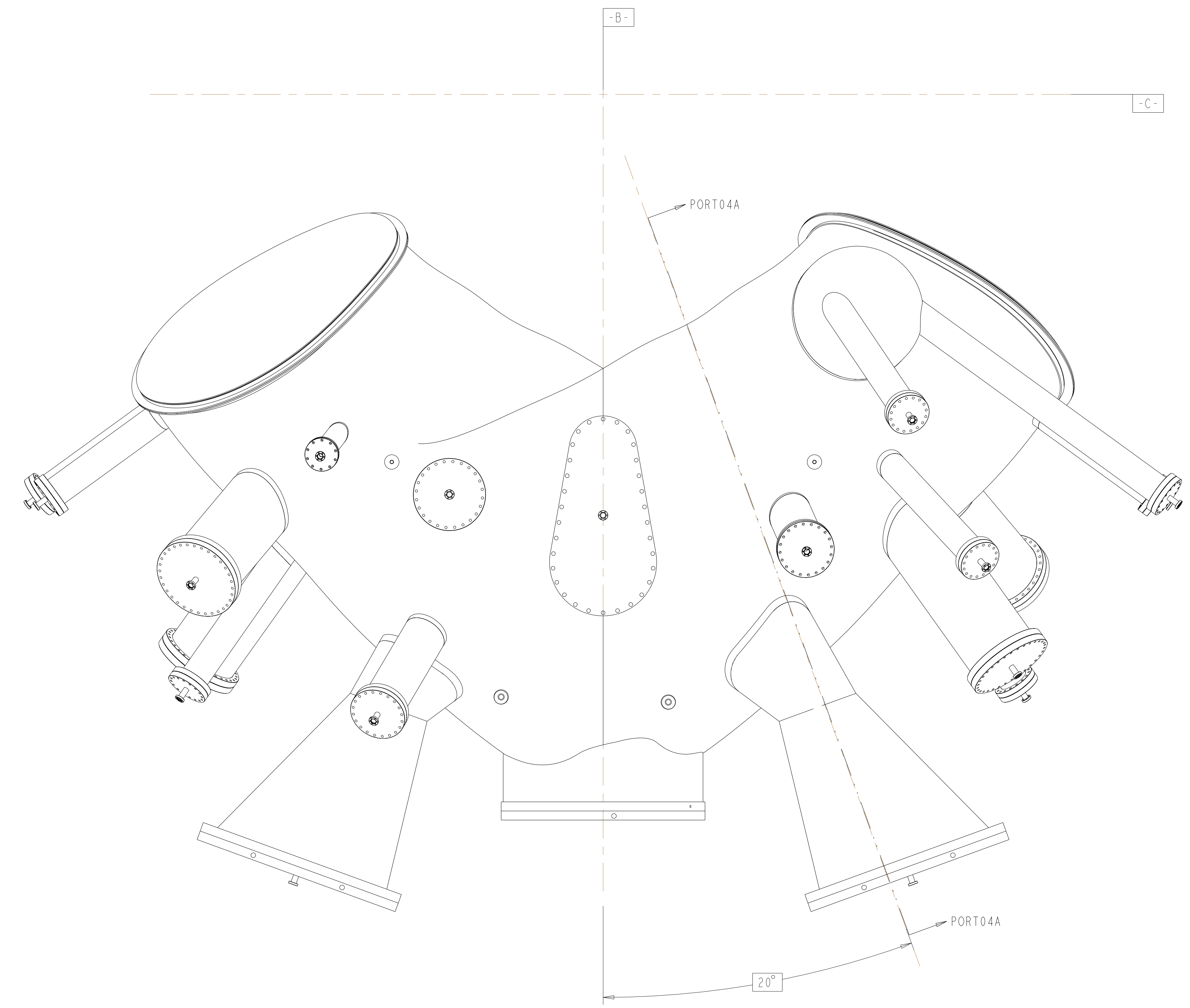

TOP VIEW

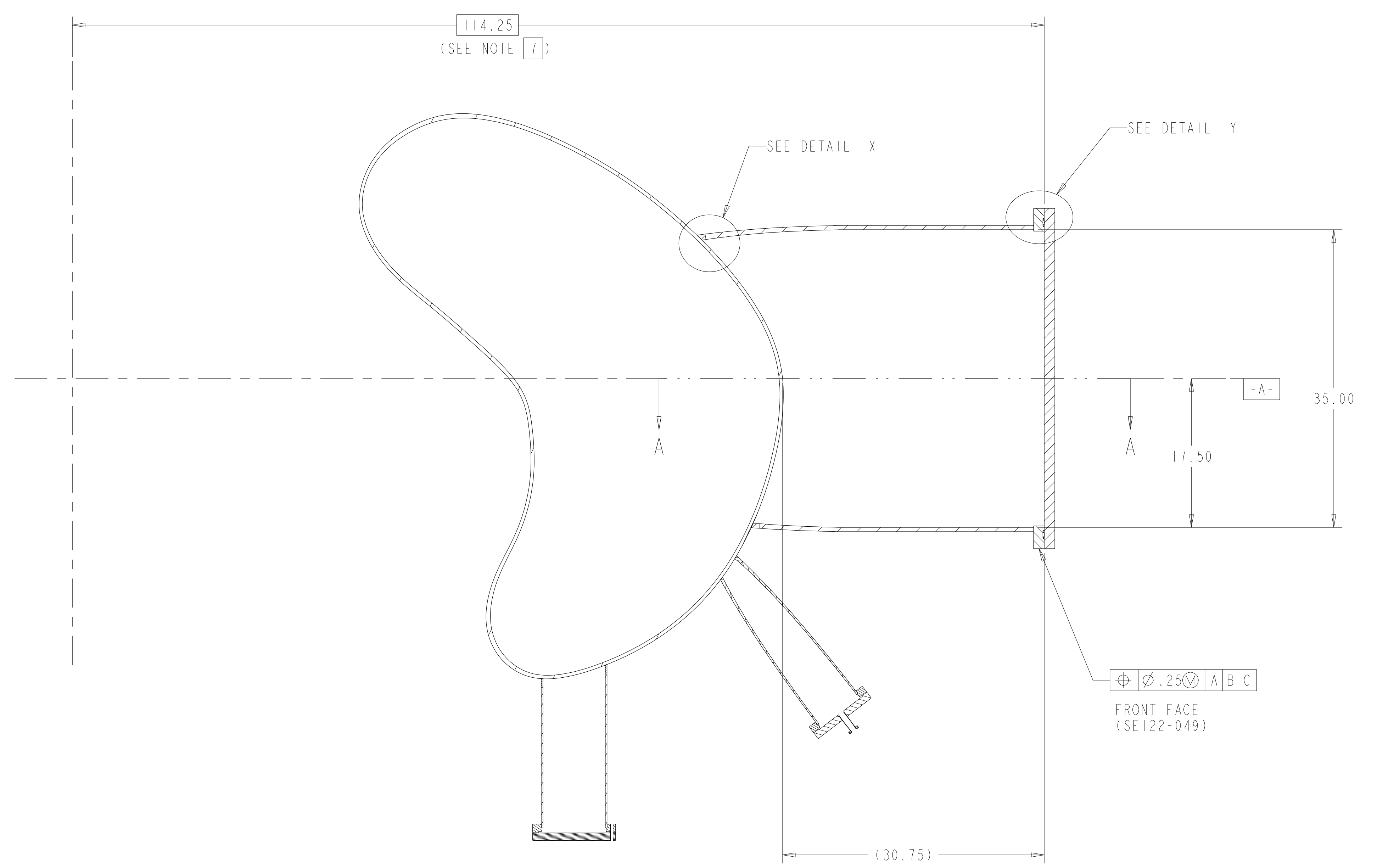

TYPICAL PORT 4A AND 4B  
SECTION PORT04A-PORT04A

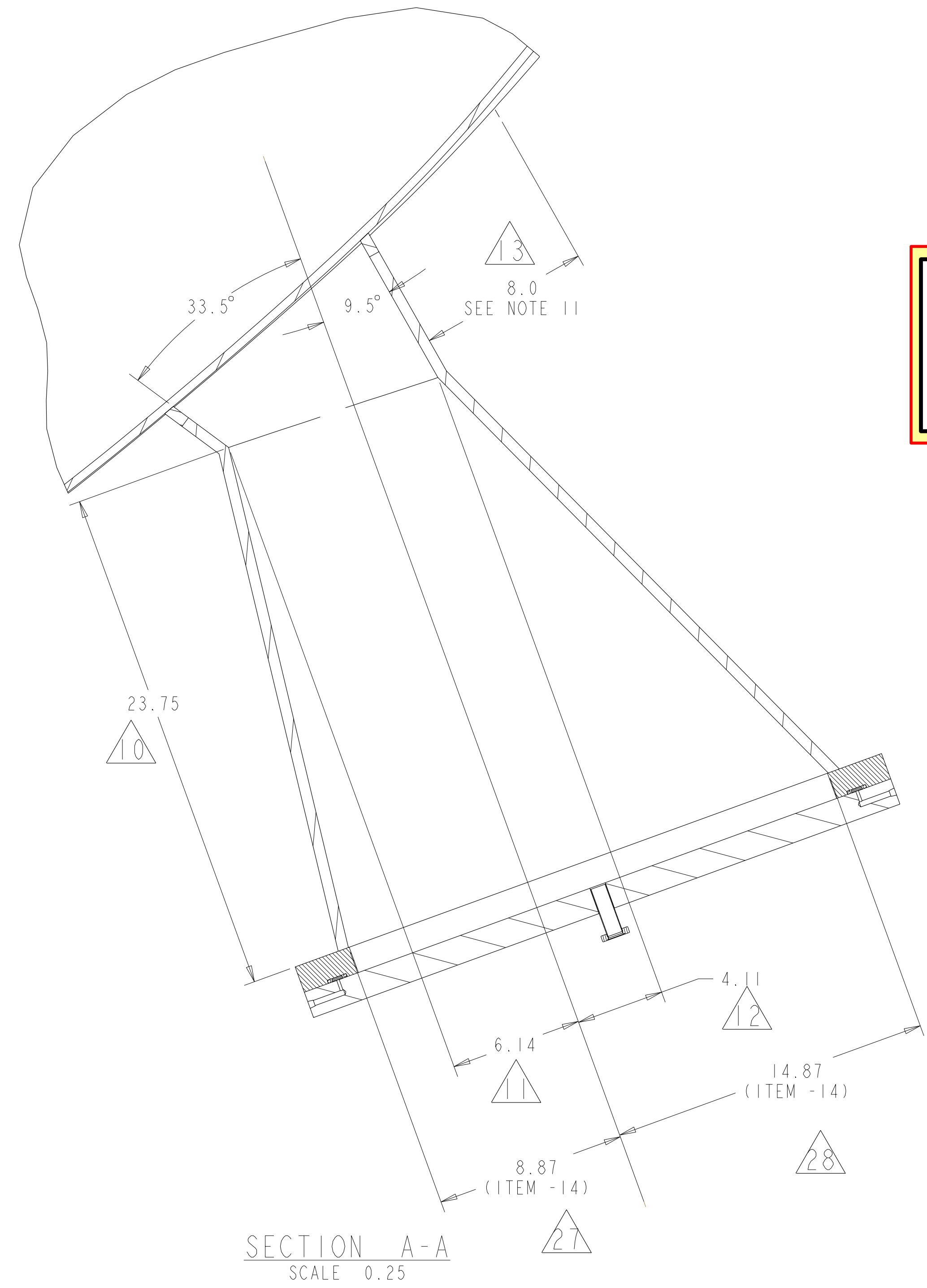

**Rev 2-e: ECN-5021 (RFD-12-017) approved alternate methods for welding the port extensions to the VVSA (See ECN-5021 for details). - Only applicable to VVSA #3 - VVSA #1 and #2 covered by NCR 19464.**

**RELEASED FOR FABRICATION / INSTALLATION**  
 PPPL Drafting:

UT-BATTELLE		Oak Ridge National Laboratory managed for the DEPARTMENT OF ENERGY under U.S. GOVERNMENT contract DE-AC05-00OR22725 UT-BATTELLE, LLC, Oak Ridge, Tennessee					
NATIONAL COMPACT STELLERATOR EXPERIMENT							
VACUUM VESSEL							
PERIOD INSPECTION AND LEAK CHECK ASSEMBLY							
VERSION NO.	PLANT	BLDG	FL	SHT OF	TYPE	CLASS	
5	X-10	5700	3	5	19	A	U
RELEASE LEVEL	SE120-004						REV
Fabrication							2

H  
G  
F  
E  
D  
C  
B  
A

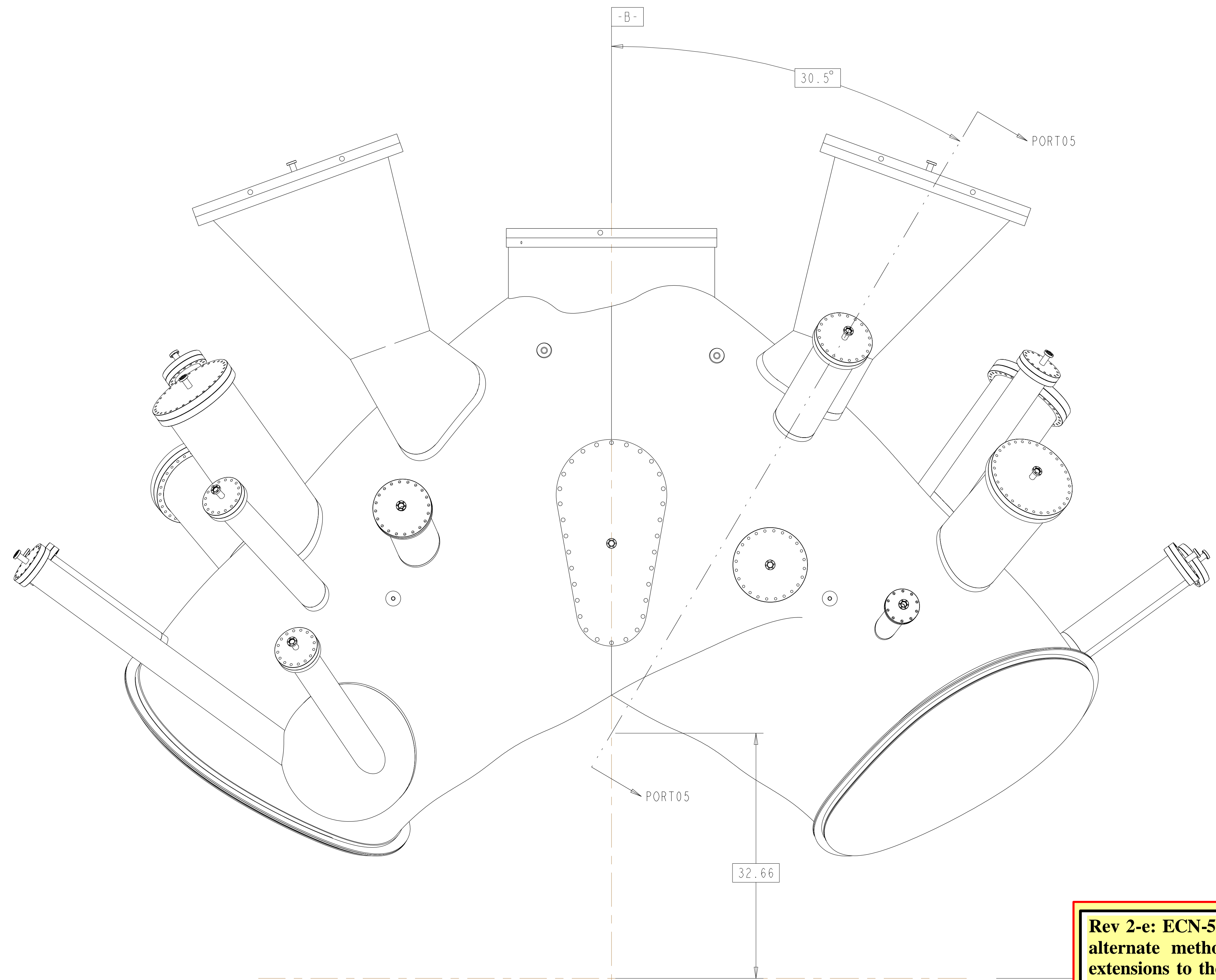

BOTTOM VIEW

**Rev 2-e: ECN-5021 (RFD-12-017) approved alternate methods for welding the port extensions to the VVSA (See ECN-5021 for details). - Only applicable to VVSA #3 - VVSA #1 and #2 covered by NCR 19464.**

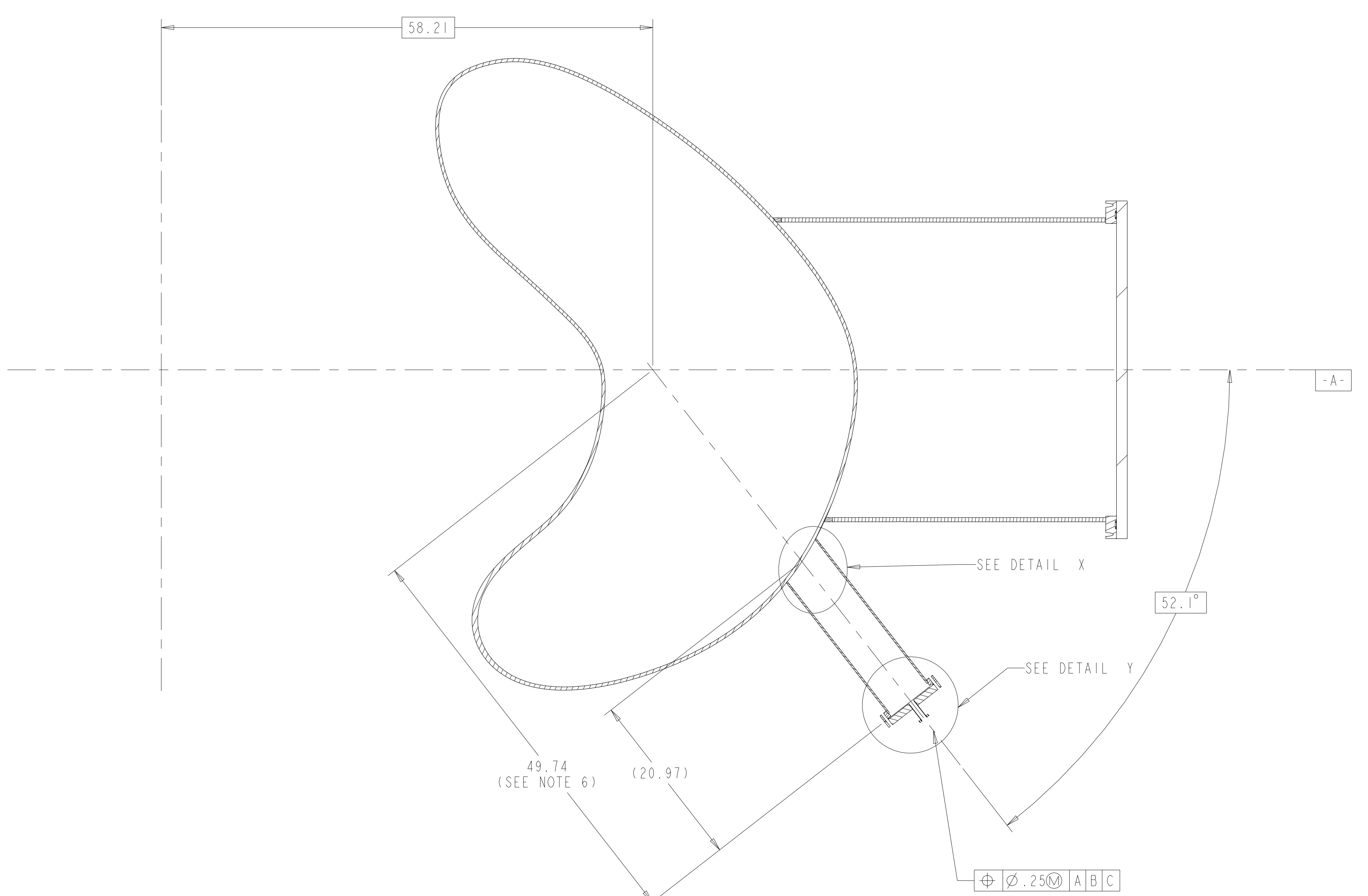

TYPICAL PORT 5A AND 5B SECTION PORT05-PORT05

FOR PARTS LIST AND NOTES SEE SHEET 1.

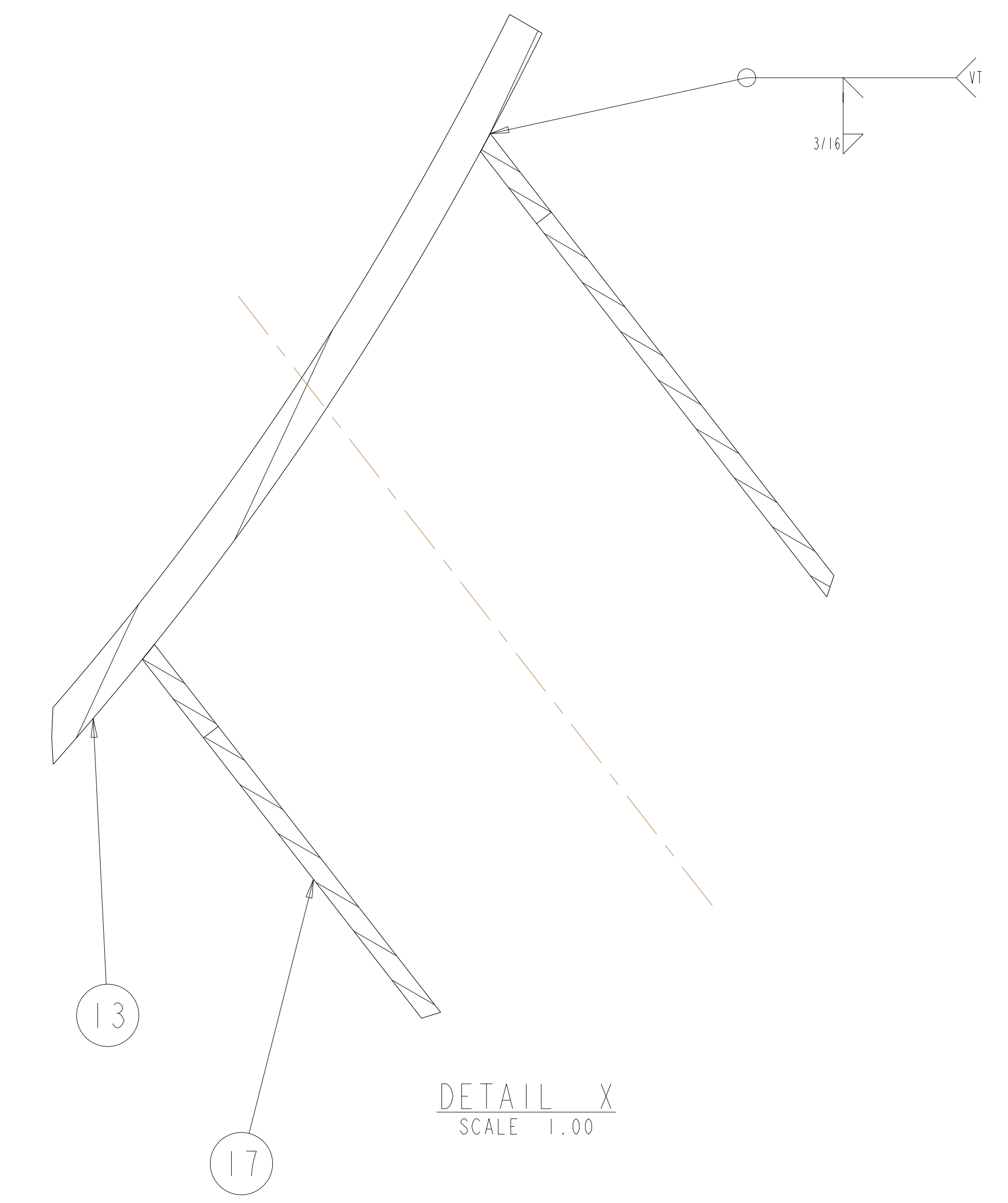

DETAIL X  
SCALE 1.00

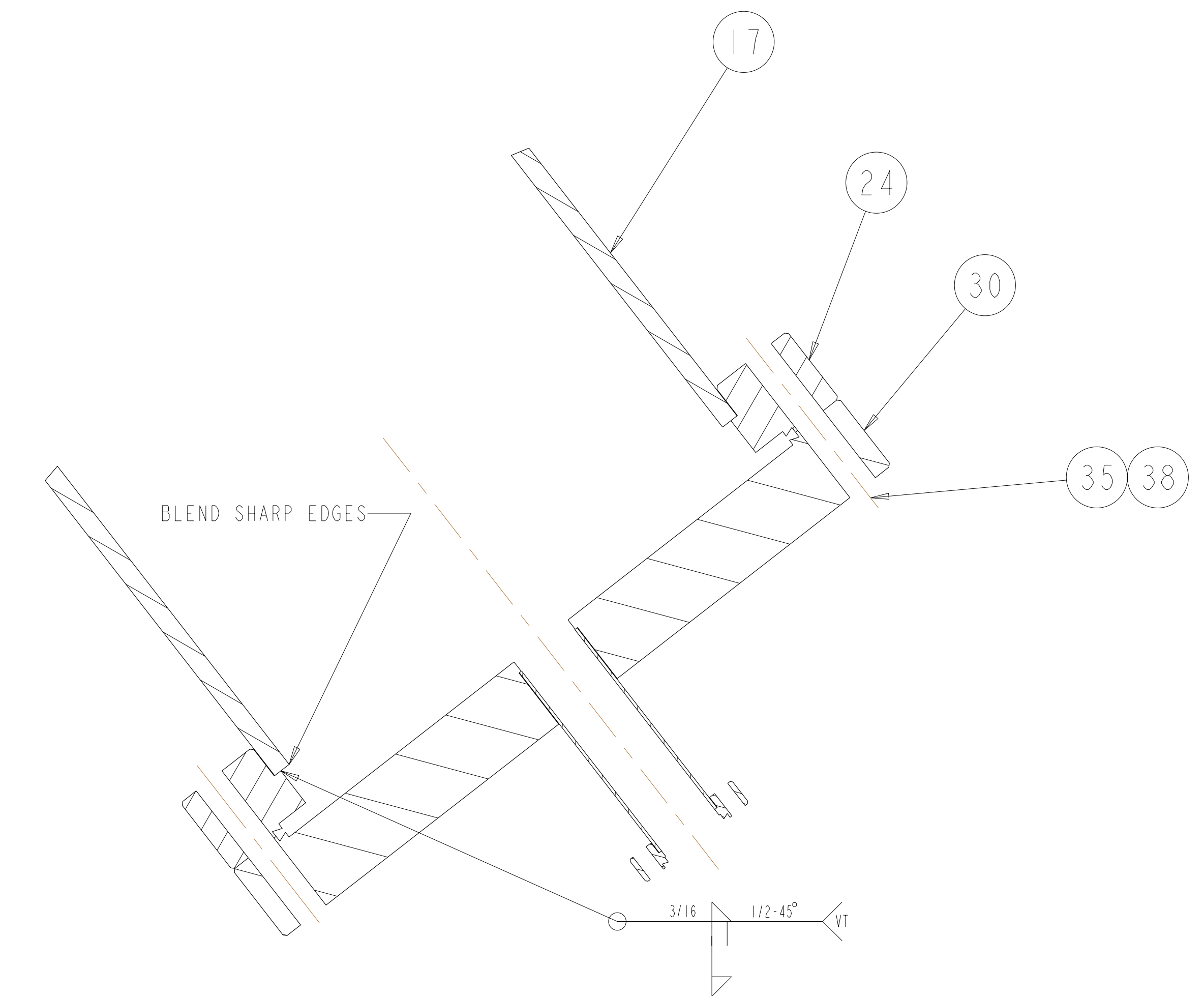

DETAIL Y  
SCALE 1.00

**RELEASED FOR FABRICATION / INSTALLATION**  
 PPPL Drafting:

UT-BATTELLE		Oak Ridge National Laboratory managed for the DEPARTMENT OF ENERGY under U.S. GOVERNMENT contract DE-AC05-00OR22725 UT-BATTELLE, LLC, Oak Ridge, Tennessee						
PROJECT NAME								
NATIONAL COMPACT STELLARATOR EXPERIMENT								
VACUUM VESSEL								
PERIOD INSPECTION AND LEAK CHECK								
ASSEMBLY								
VERSION NO.	PLANT	BLDG	FL	SHT OF	TYPE	CLASS		
5	X-10	5700	3	6	19	A	U	
RELEASE LEVEL		SE120-004					REV	
Fabrication							2	

H  
G  
F  
E  
D  
C  
B  
A

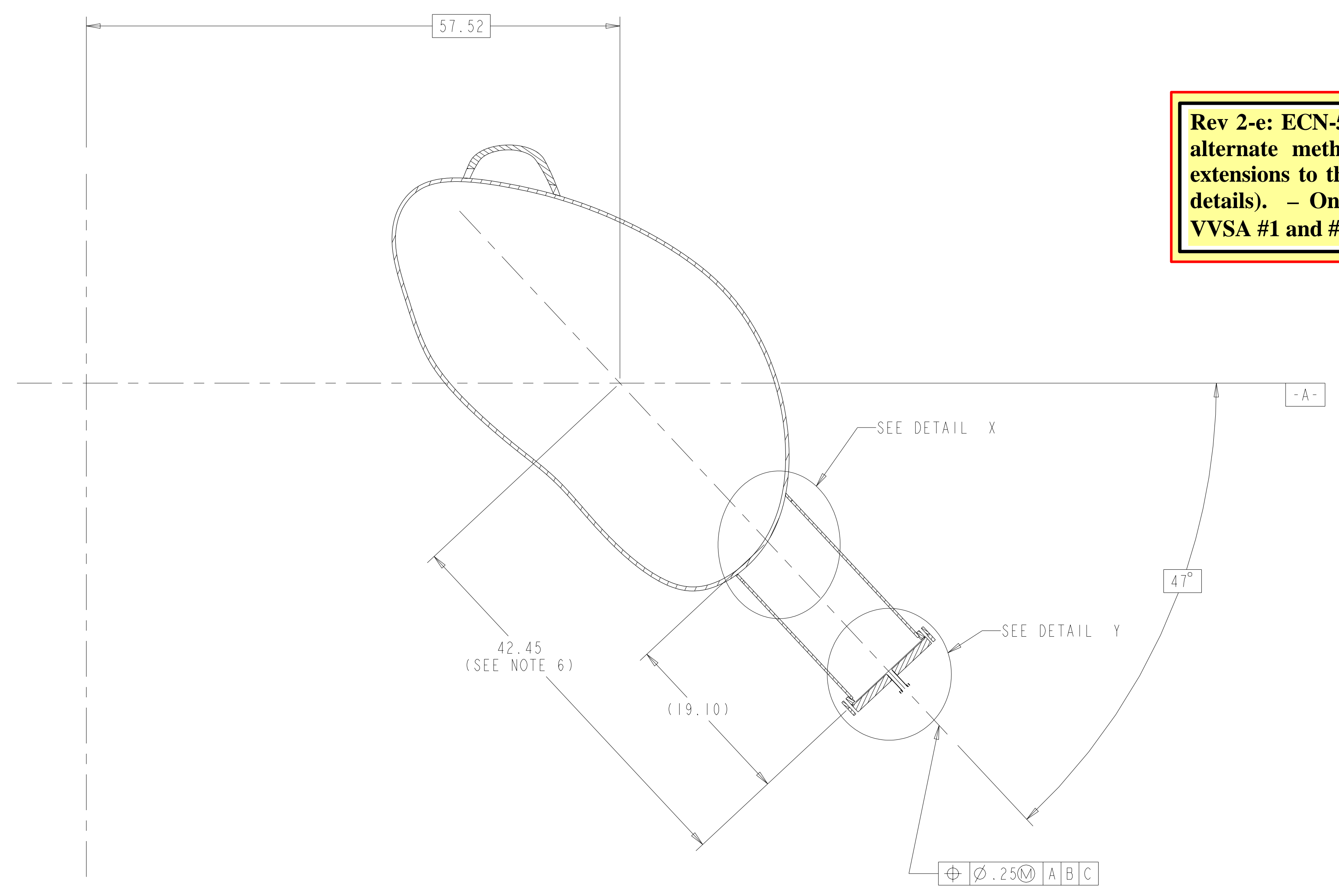
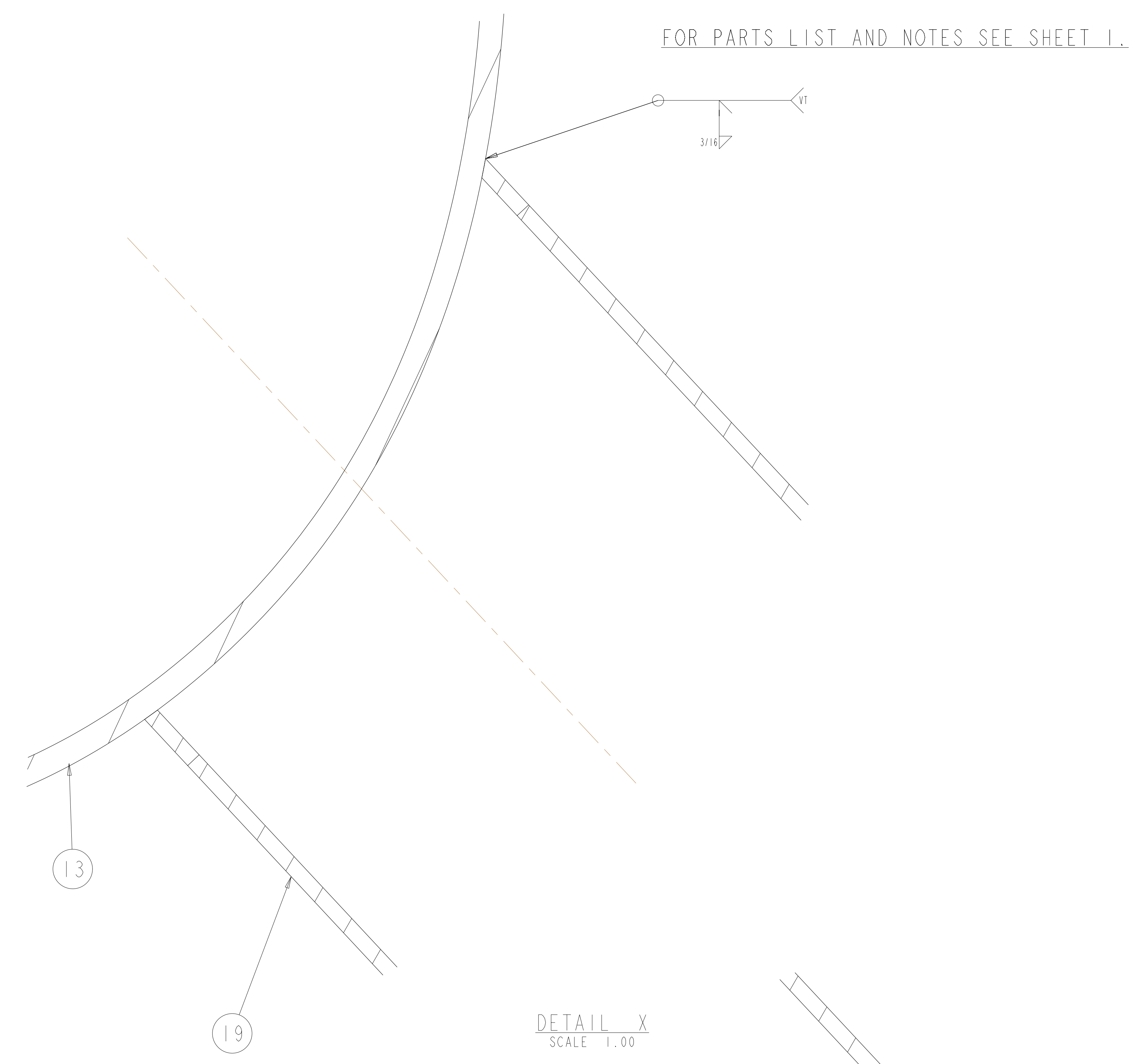
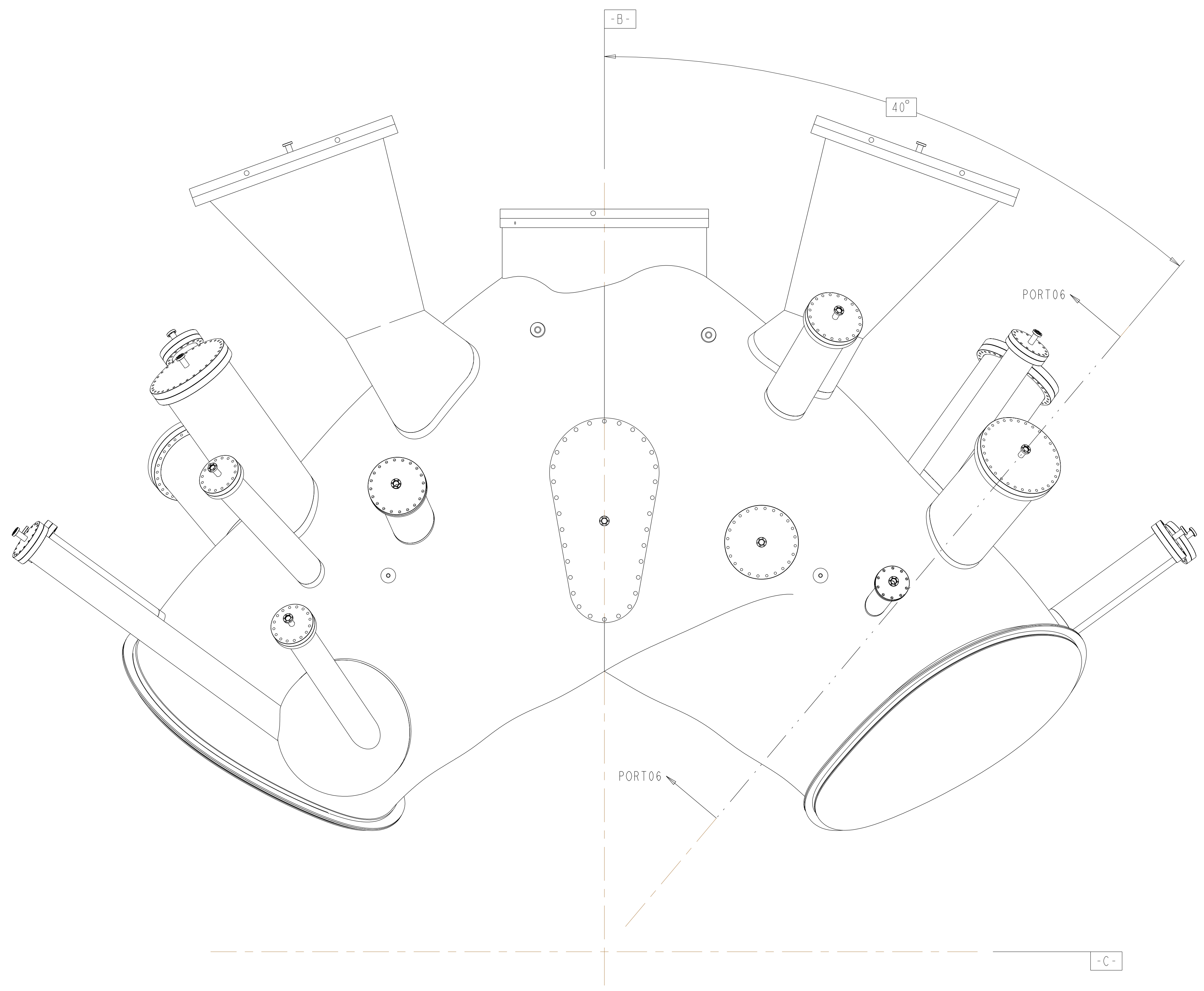

**Rev 2-e: ECN-5021 (RFD-12-017) approved alternate methods for welding the port extensions to the VVSA (See ECN-5021 for details). - Only applicable to VVSA #3 - VVSA #1 and #2 covered by NCR 19464.**

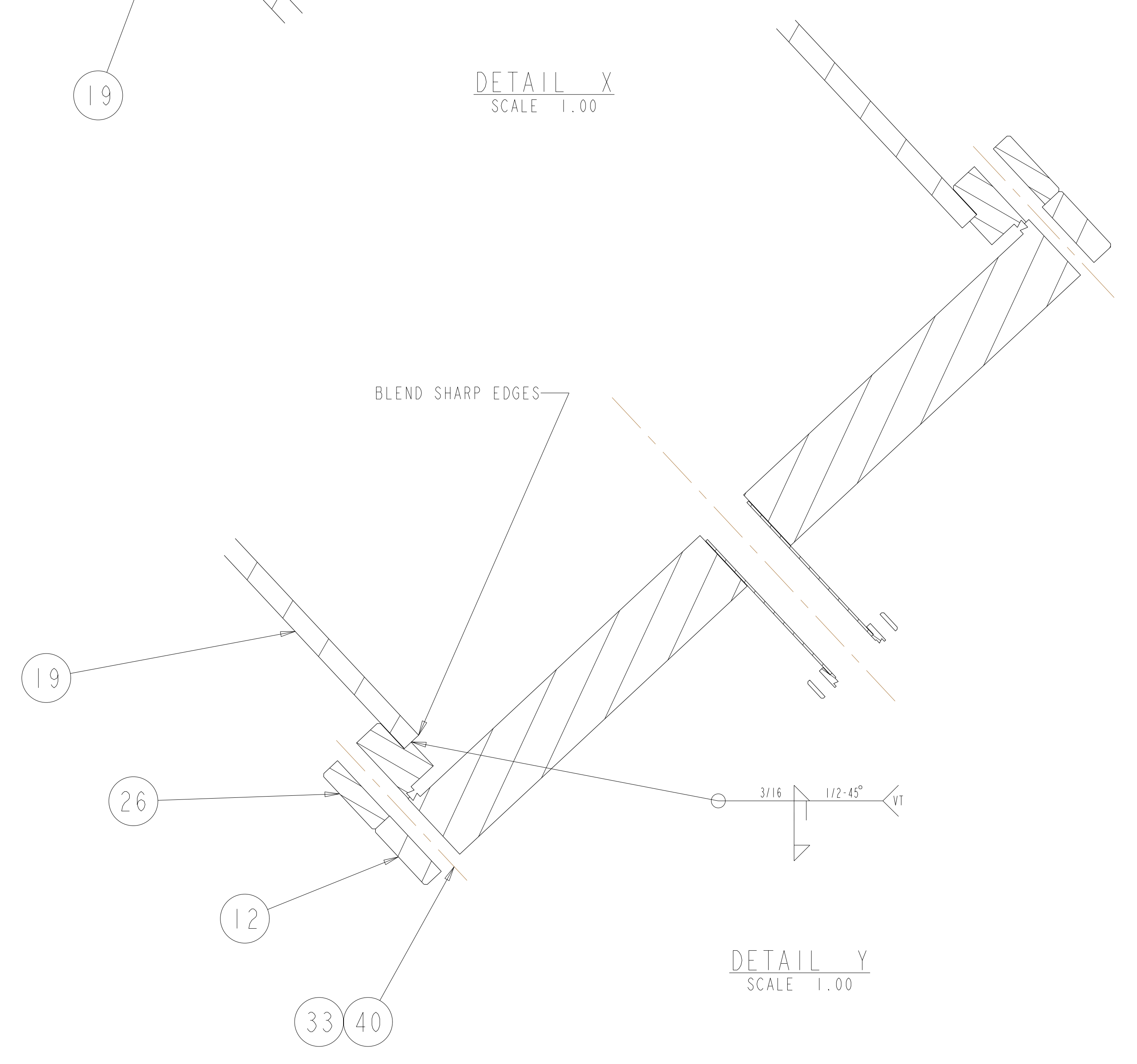

TYPICAL PORT 6A AND 6B SECTION PORT06-PORT06

**RELEASED FOR FABRICATION / INSTALLATION**  
 PPPL Drafting:

UT-BATTELLE		Oak Ridge National Laboratory managed for the DEPARTMENT OF ENERGY under U.S. GOVERNMENT contract DE-AC05-00OR22725 UT-BATTELLE, LLC, Oak Ridge, Tennessee					
NATIONAL COMPACT STELLARATOR EXPERIMENT		PROJECT NAME					
VACUUM VESSEL		PERIOD INSPECTION AND LEAK CHECK ASSEMBLY					
VERSION NO.	PLANT	BLDG	FL	SHT OF	TYPE	CLASS	
5	X-10	5700	3	7 19	A	U	
RELEASE LEVEL	SEI20-004						REV
Fabrication							2

H  
G  
F  
E  
D  
C  
B  
A

SEI20-004

FOR PARTS LIST AND NOTES SEE SHEET 1.

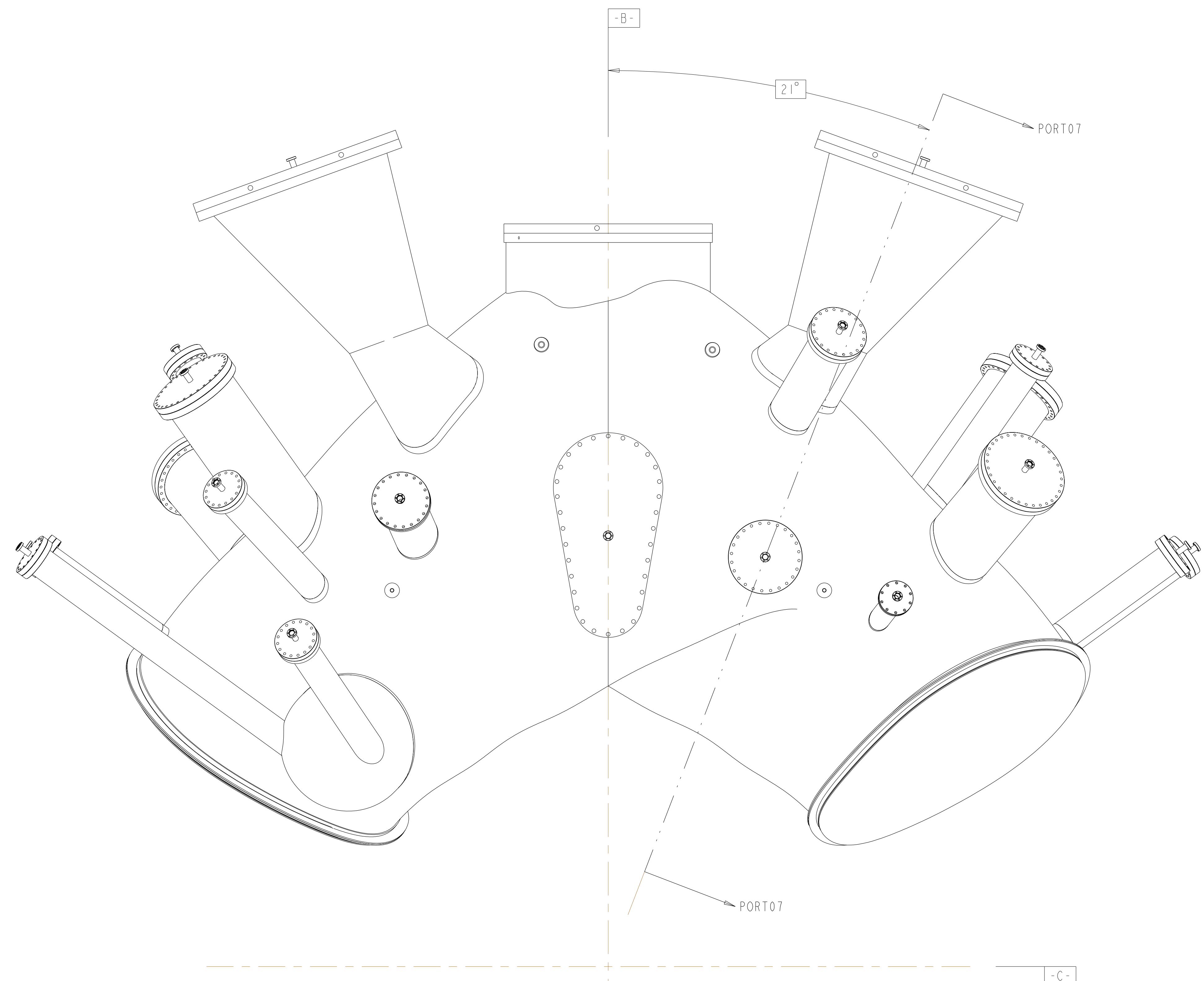

BOTTOM VIEW

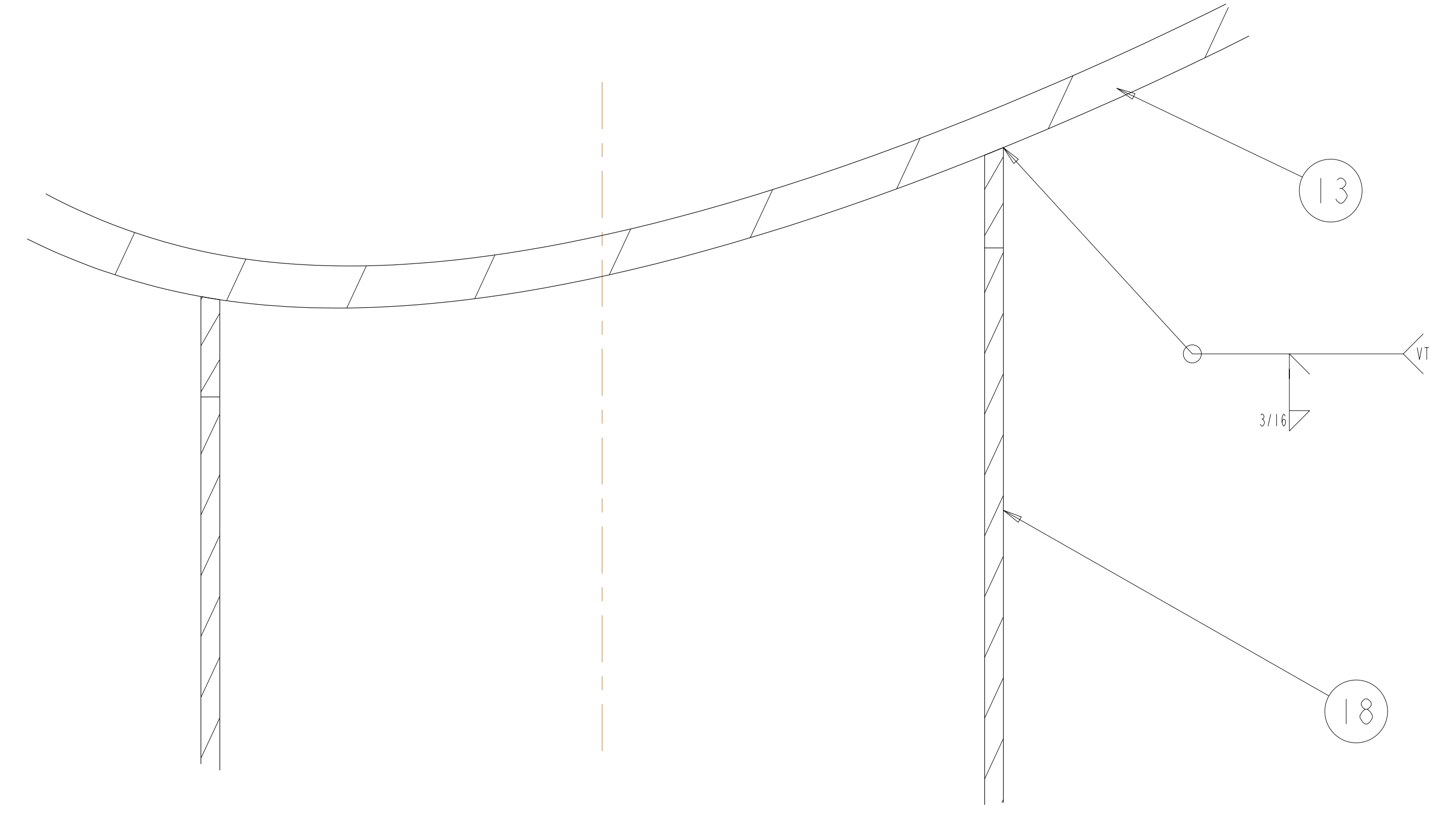

DETAIL X  
SCALE 1.00

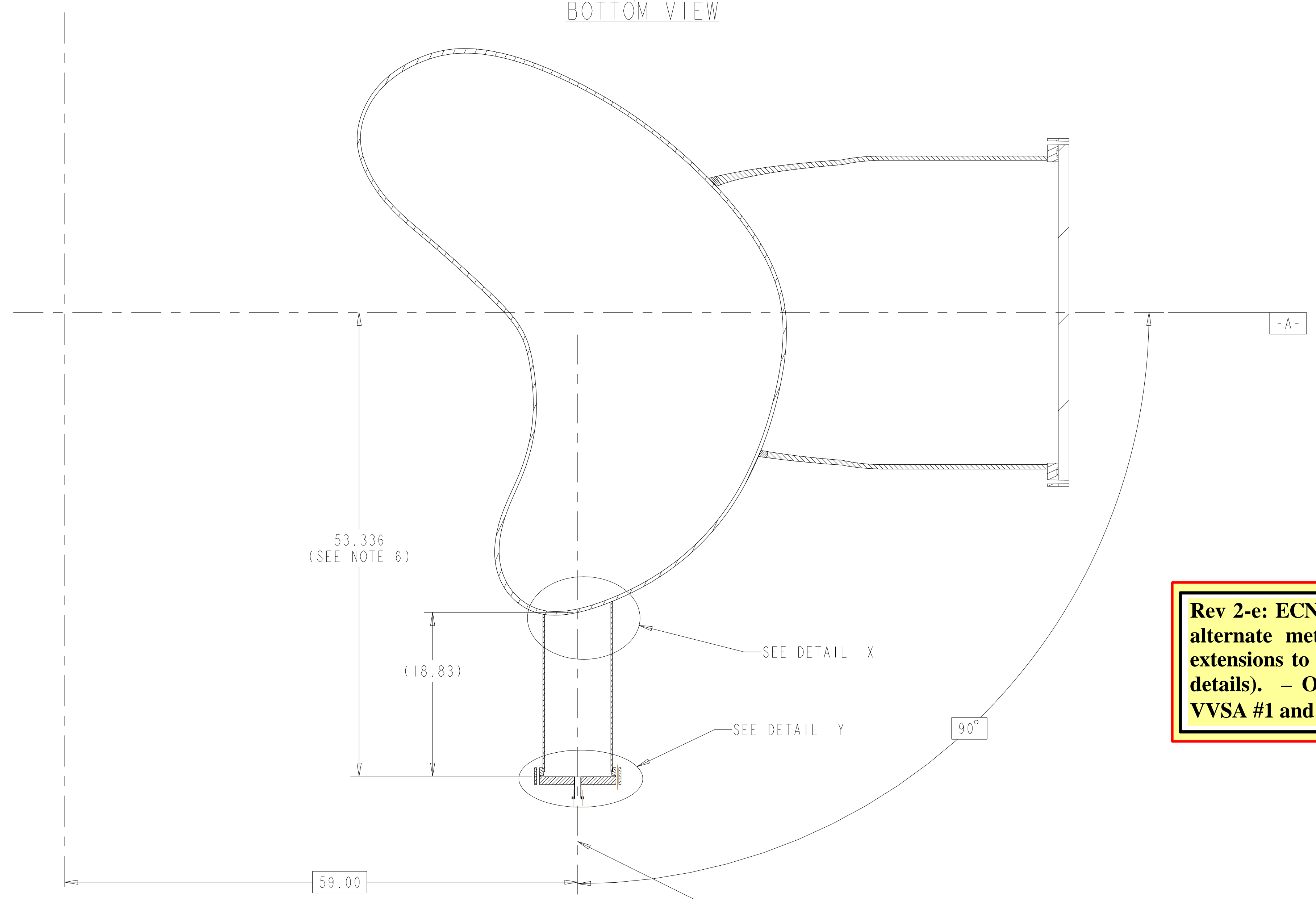

TYPICAL PORT 7A AND 7B  
SECTION PORT07-PORT07

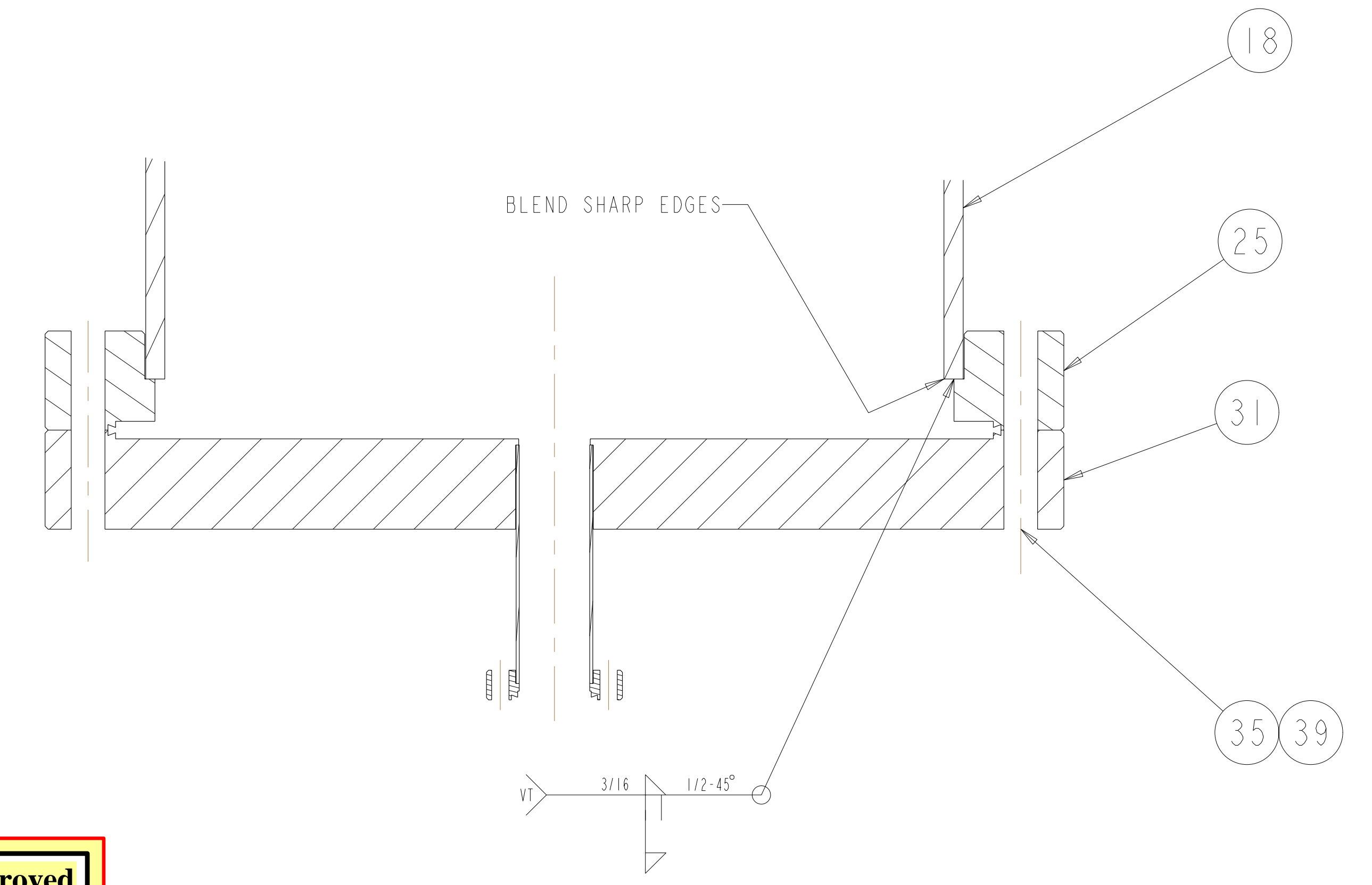

DETAIL Y  
SCALE 1.00

**Rev 2-e: ECN-5021 (RFD-12-017) approved alternate methods for welding the port extensions to the VVSA (See ECN-5021 for details). - Only applicable to VVSA #3 - VVSA #1 and #2 covered by NCR 19464.**

**RELEASED FOR FABRICATION / INSTALLATION**  
 PPPL Drafting:

UT-BATTELLE		Oak Ridge National Laboratory managed for the DEPARTMENT OF ENERGY under U.S. GOVERNMENT contract DE-AC05-00OR22725 UT-BATTELLE, LLC, Oak Ridge, Tennessee	
PROJECT NAME			
NATIONAL COMPACT STELLARATOR EXPERIMENT			
VACUUM VESSEL			
PERIOD INSPECTION AND LEAK CHECK			
ASSEMBLY			
VERSION NO.	PLANT	BLDG	FL
5	X-10	5700	3
RELEASE LEVEL	SHT OF	TYPE	CLASS
Fabrication	8	19	A
SE120-004			REV
			2

SE120-004



FOR PARTS LIST AND NOTES SEE SHEET 1.

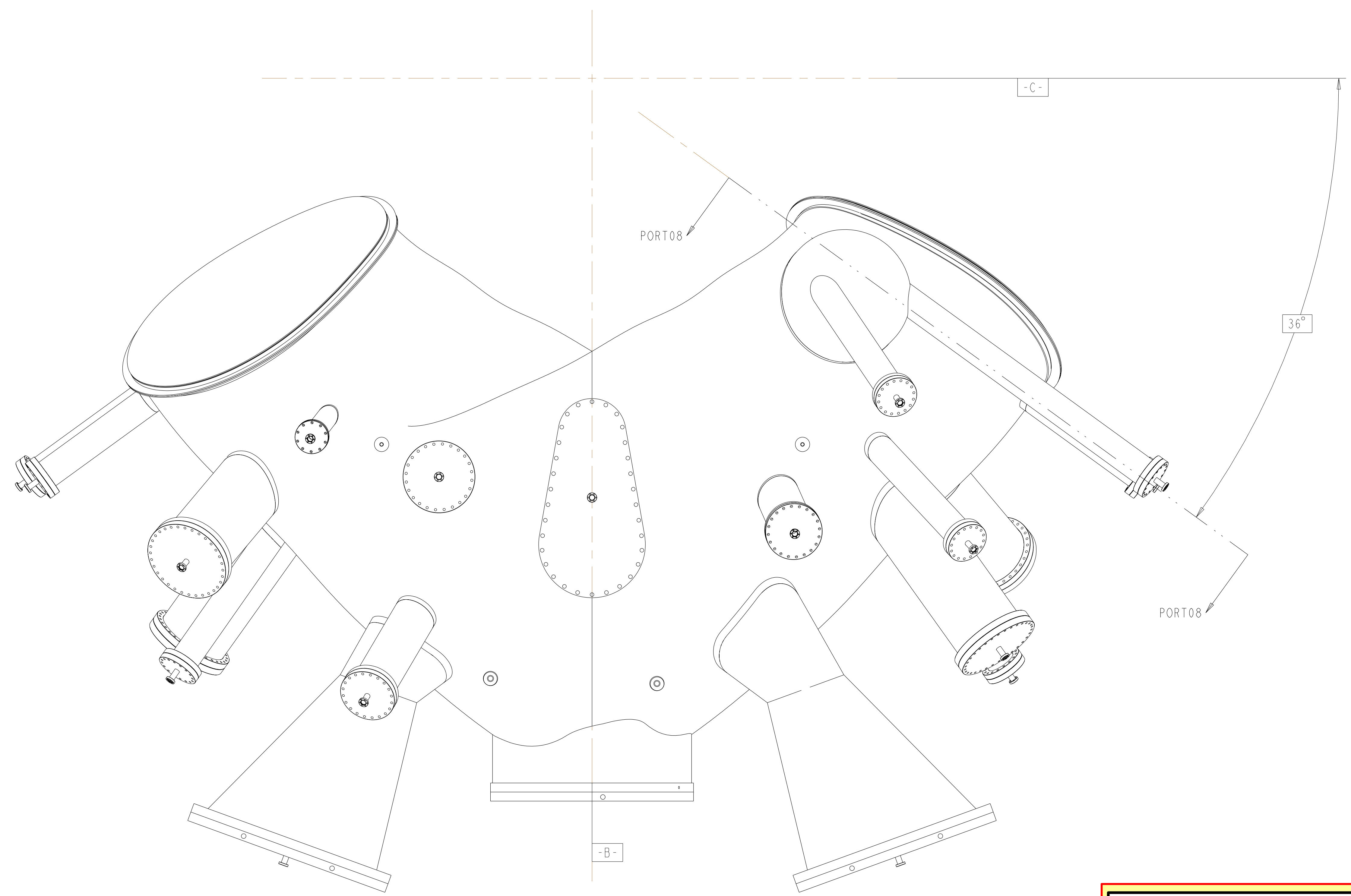

TOP VIEW

Rev 2-e: ECN-5021 (RFD-12-017) approved alternate methods for welding the port extensions to the VVSA (See ECN-5021 for details). - Only applicable to VVSA #3 - VVSA #1 and #2 covered by NCR 19464.

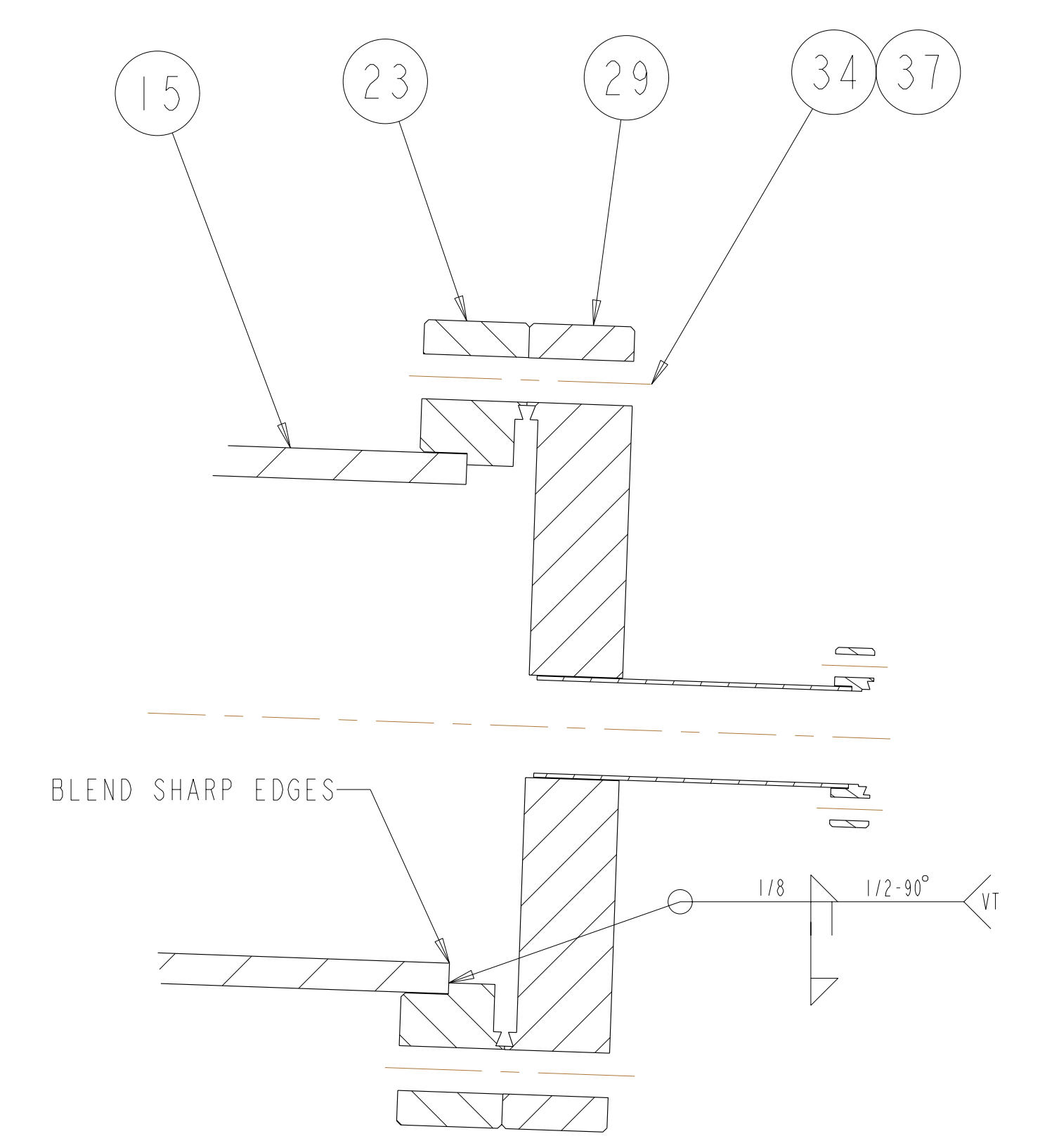

DETAIL Y  
SCALE 1.00

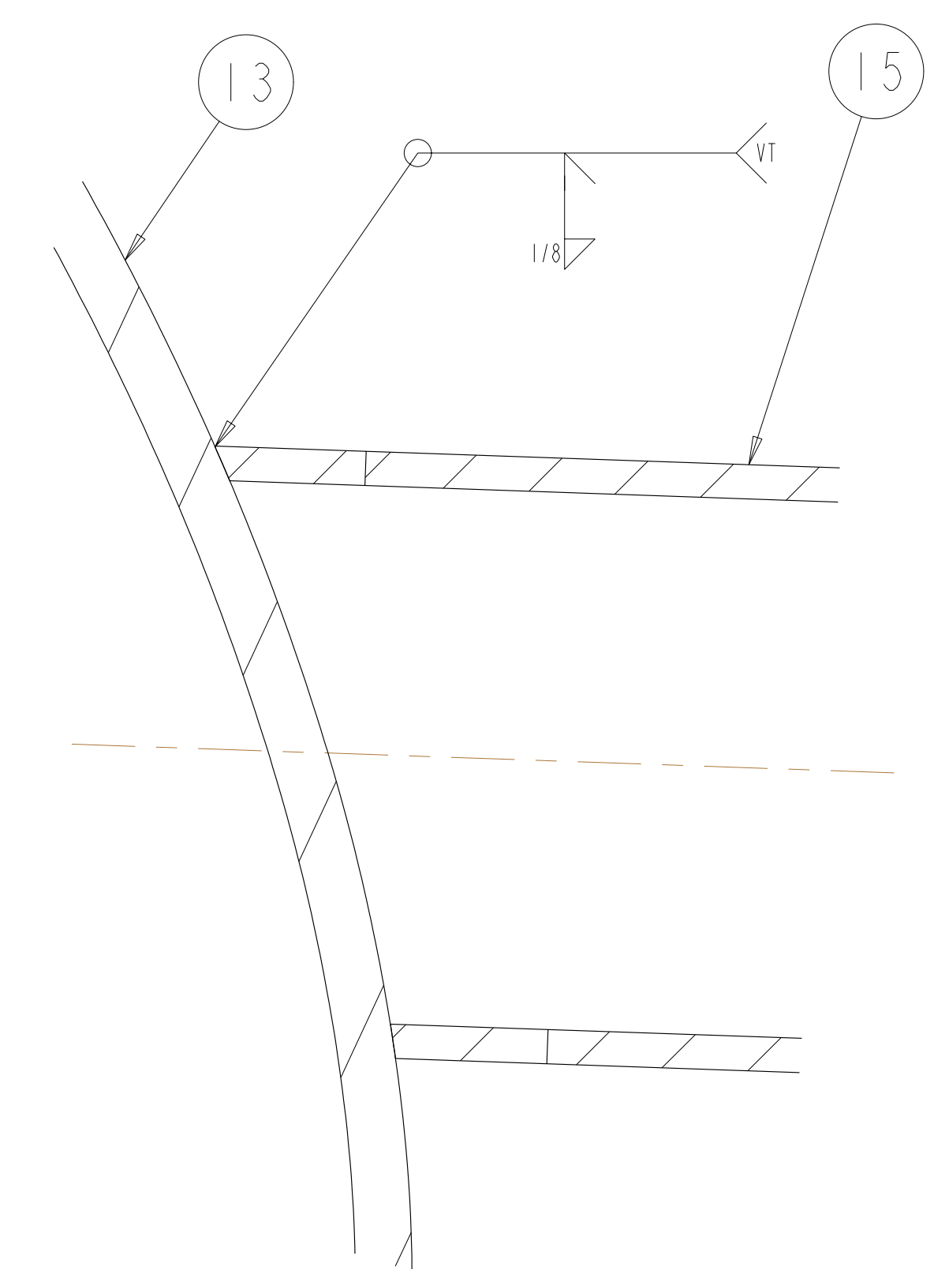

DETAIL X  
SCALE 1.00

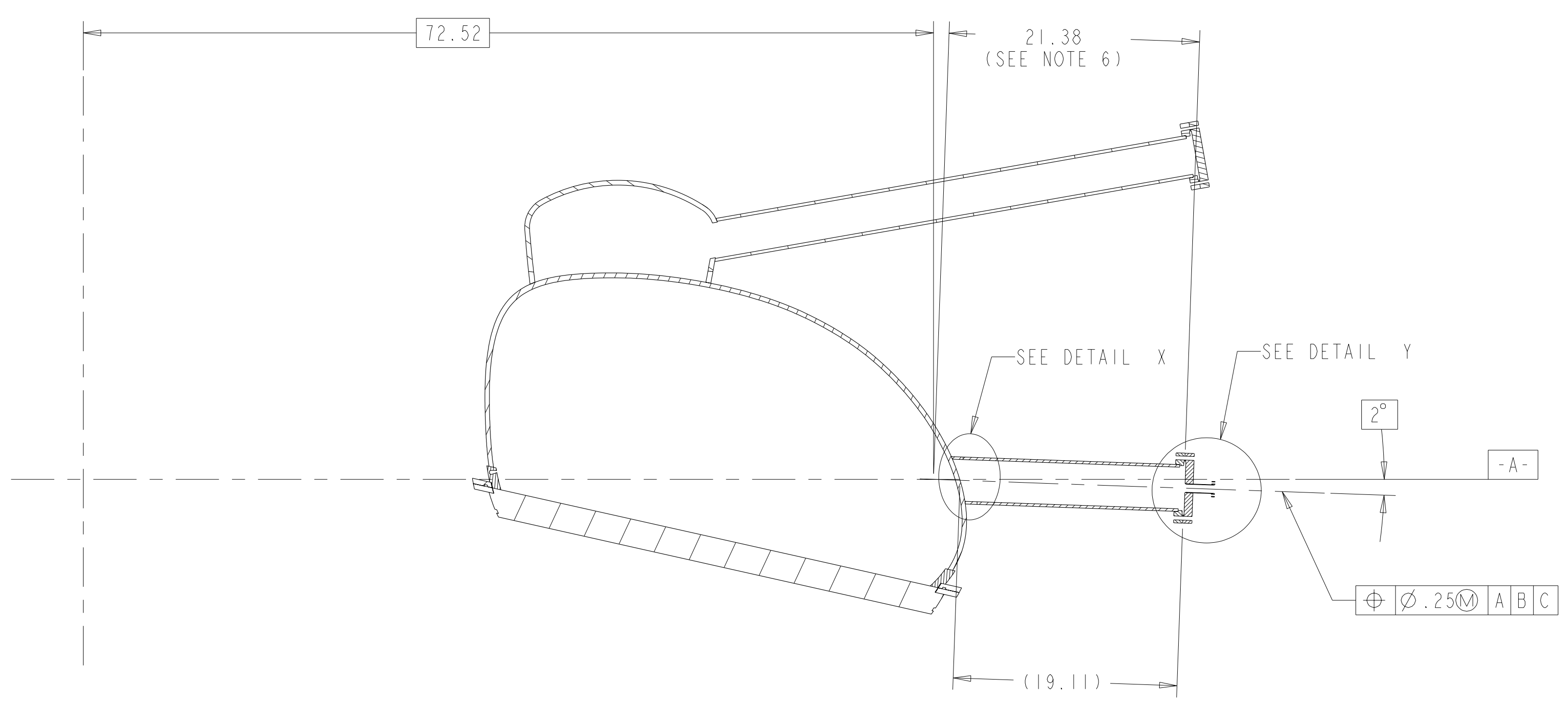

TYPICAL PORT 8A AND 8B  
SECTION PORT08-PORT08

**RELEASED FOR  
FABRICATION / INSTALLATION**  
PPPL Drafting:

UT-BATTELLE		Oak Ridge National Laboratory managed for the DEPARTMENT OF ENERGY under U.S. GOVERNMENT contract DE-AC05-00OR22725 UT-BATTELLE, LLC, Oak Ridge, Tennessee	
PROJECT NAME			
NATIONAL COMPACT STELLERATOR EXPERIMENT			
VACUUM VESSEL			
PERIOD INSPECTION AND LEAK CHECK			
ASSEMBLY			
VERSION NO.	PLANT	BLDG	FL
5	X-10	5700	3
RELEASE LEVEL	SHT OF	TYPE	CLASS
Fabrication	19	A	U
SE120-004			REV
			2

SE120-004

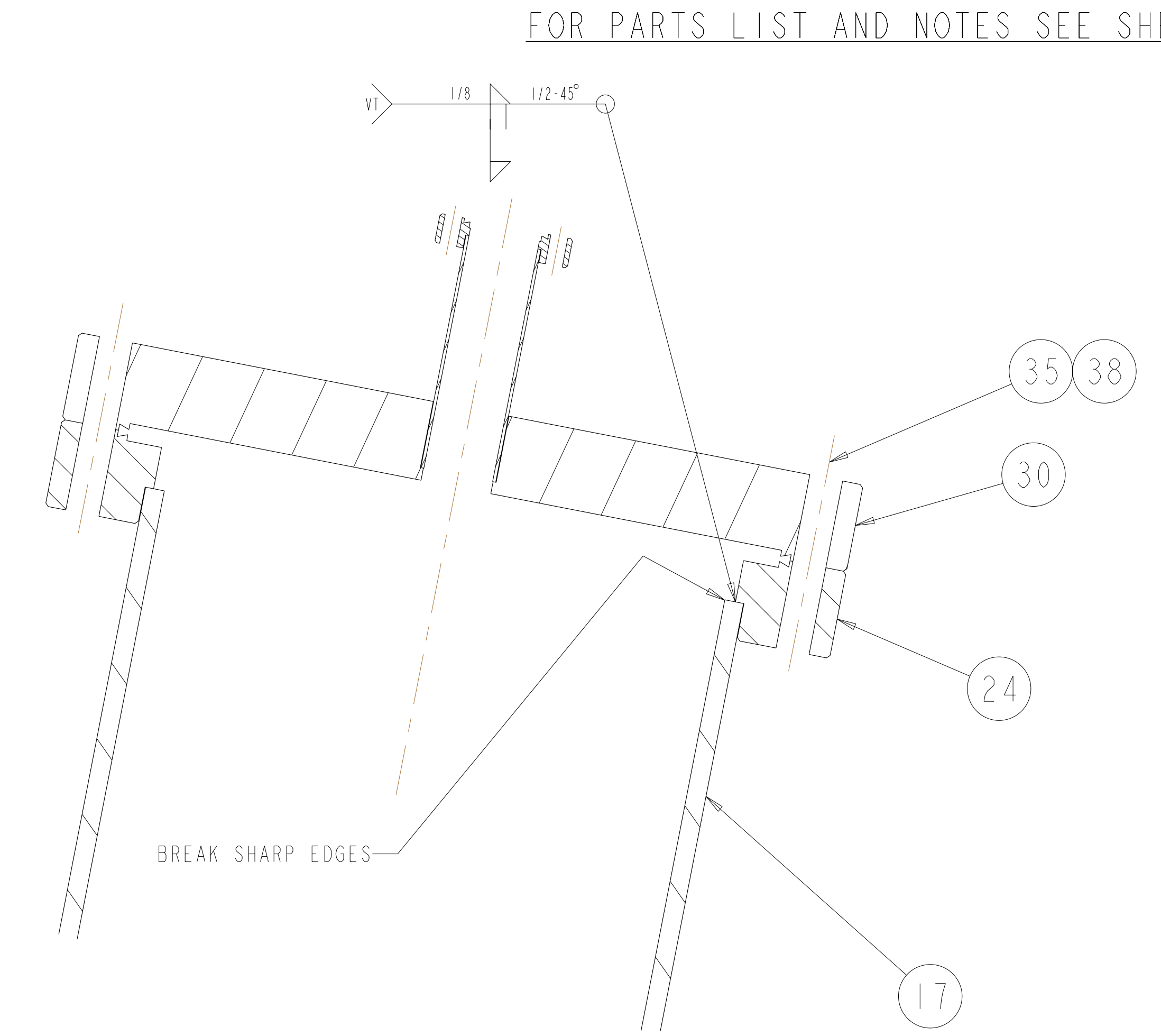
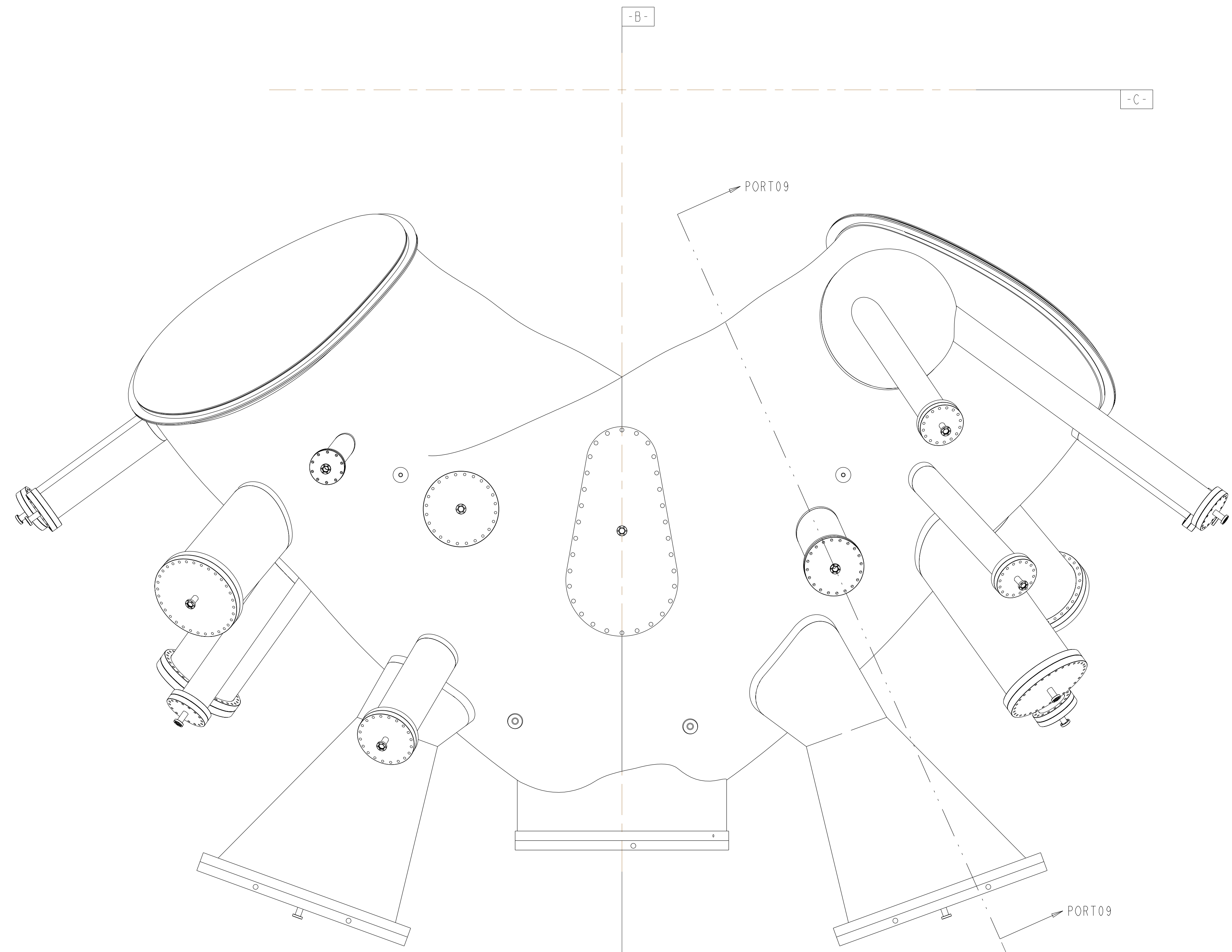

DETAIL Y  
SCALE 1.00

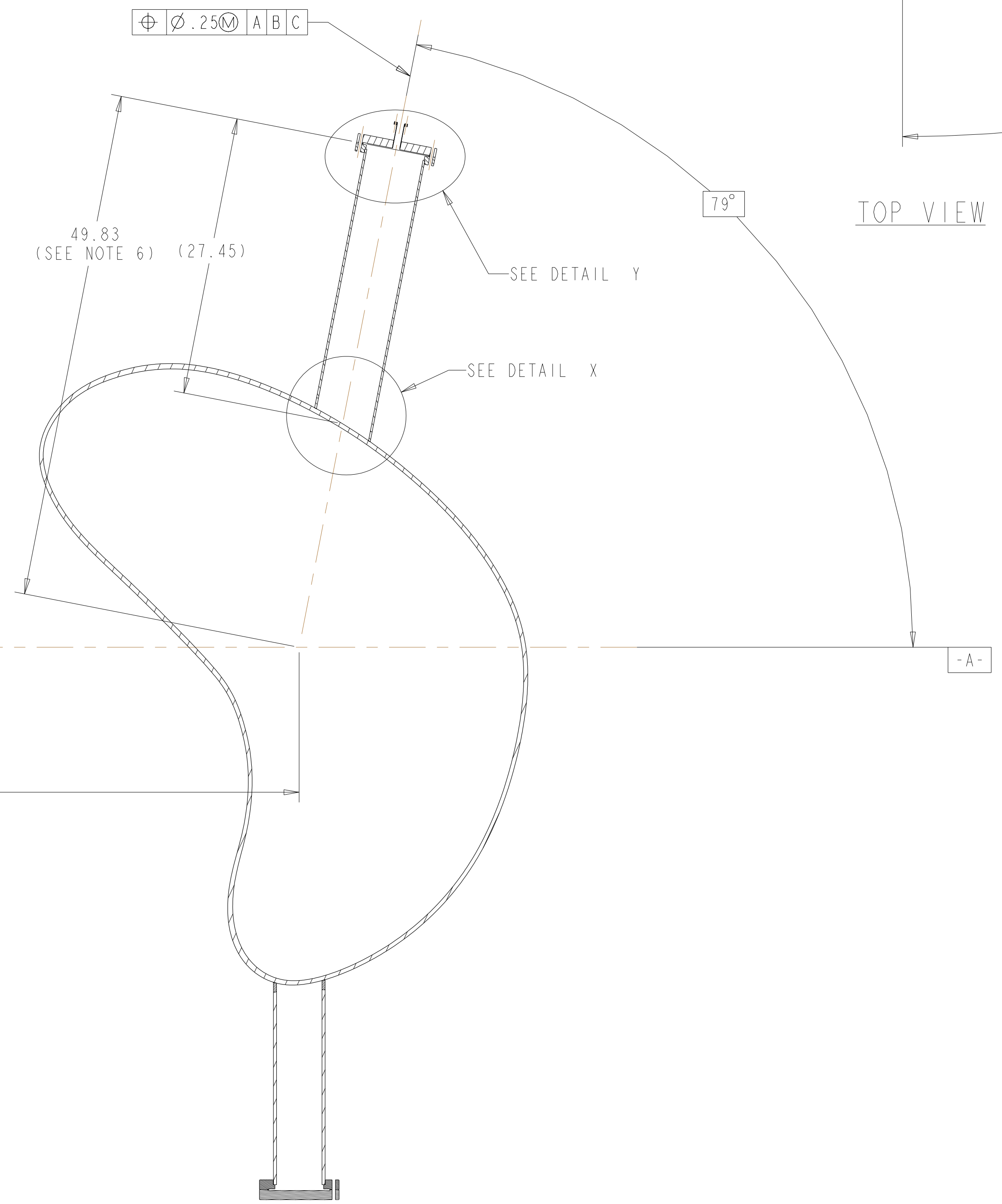

TOP VIEW

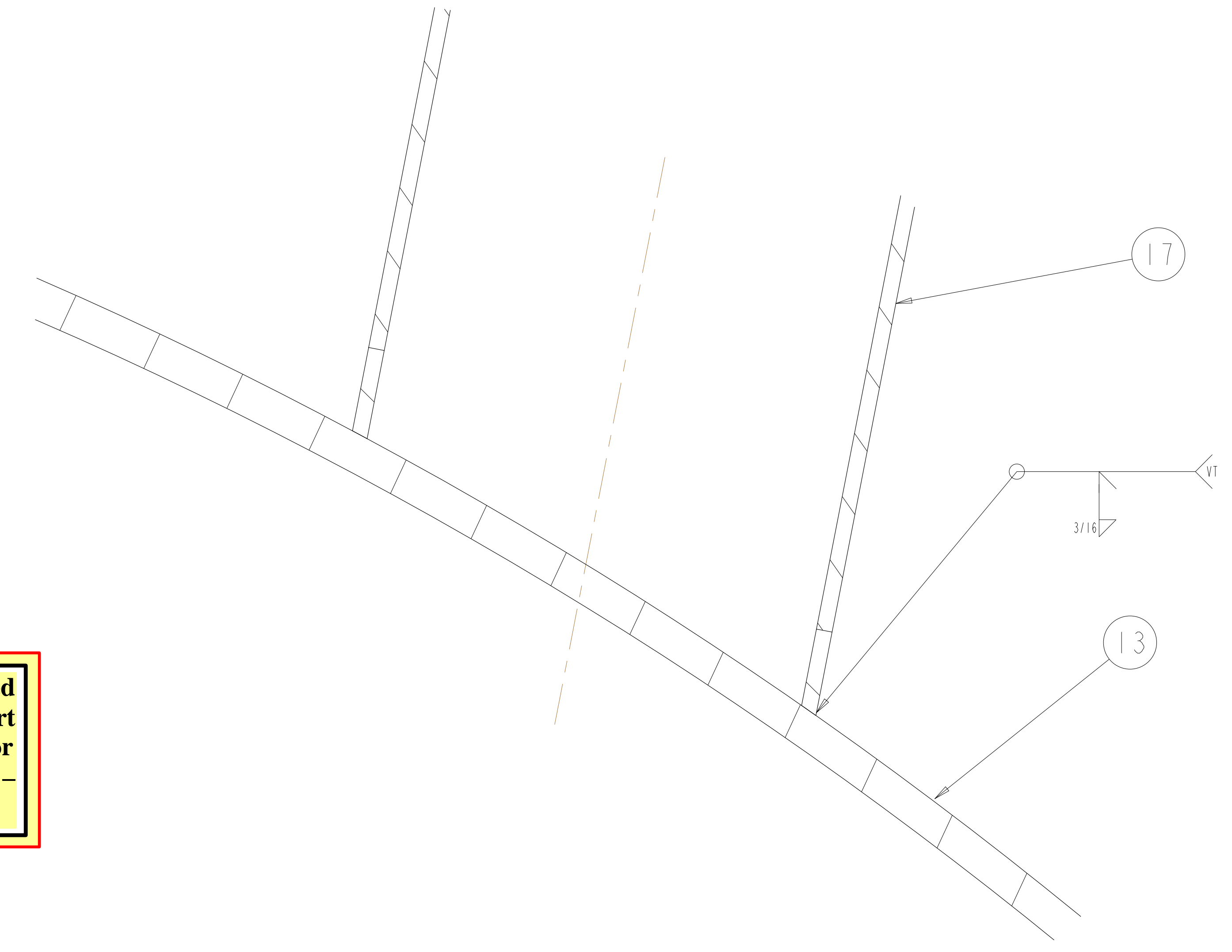

DETAIL X  
SCALE 1.00

**Rev 2-e: ECN-5021 (RFD-12-017) approved alternate methods for welding the port extensions to the VVSA (See ECN-5021 for details). - Only applicable to VVSA #3 - VVSA #1 and #2 covered by NCR 19464.**

**RELEASED FOR FABRICATION / INSTALLATION**  
 PPPL Drafting:

TYPICAL PORT 9A AND 9B  
 SECTION PORT09-PORT09

UT-BATTELLE		Oak Ridge National Laboratory managed for the DEPARTMENT OF ENERGY under U.S. GOVERNMENT contract DE-AC05-00OR22725 UT-BATTELLE, LLC, Oak Ridge, Tennessee					
PROJECT NAME							
NATIONAL COMPACT STELLARATOR EXPERIMENT							
VACUUM VESSEL							
PERIOD INSPECTION AND LEAK CHECK							
ASSEMBLY							
VERSION NO.	PLANT	BLDG	FL	SHT OF	TYPE	CLASS	
5	X-10	5700	3	10	19	A	U
RELEASE LEVEL							
Fabrication		SE120-004					
							REV 2

H  
G  
F  
E  
D  
C  
B  
A

FOR PARTS LIST AND NOTES SEE SHEET 1.

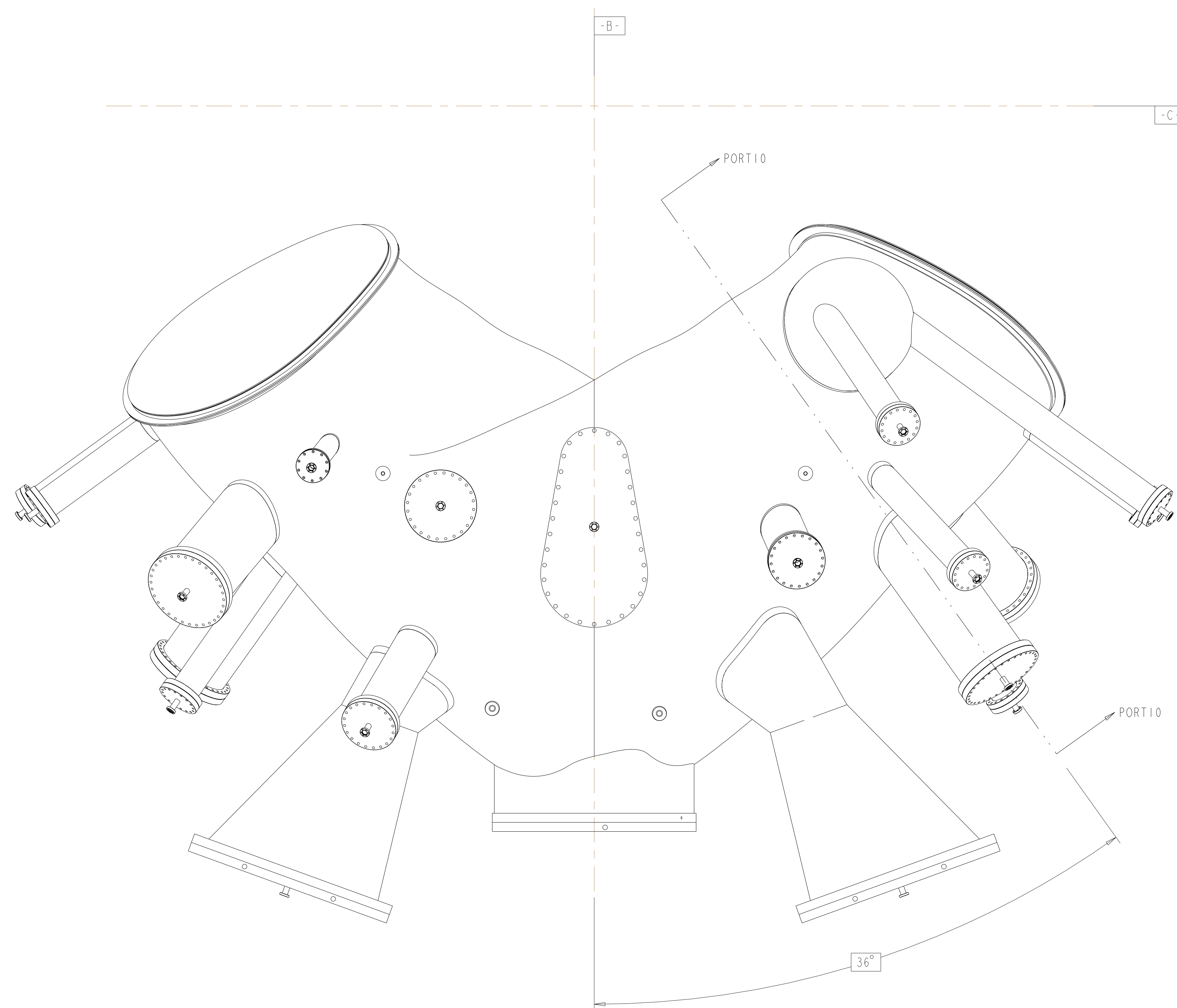

TOP VIEW

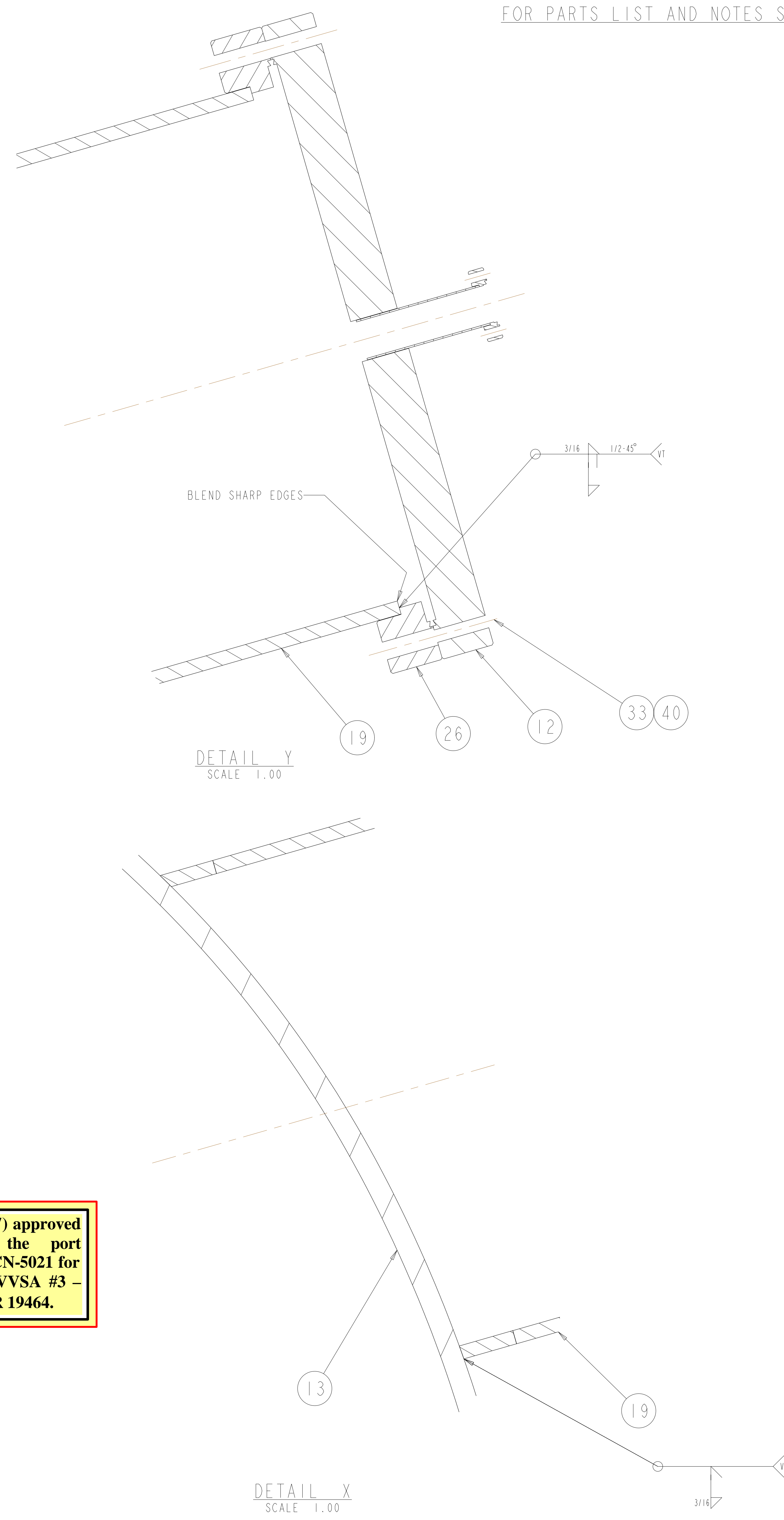

DETAIL Y  
SCALE 1.00

DETAIL X  
SCALE 1.00

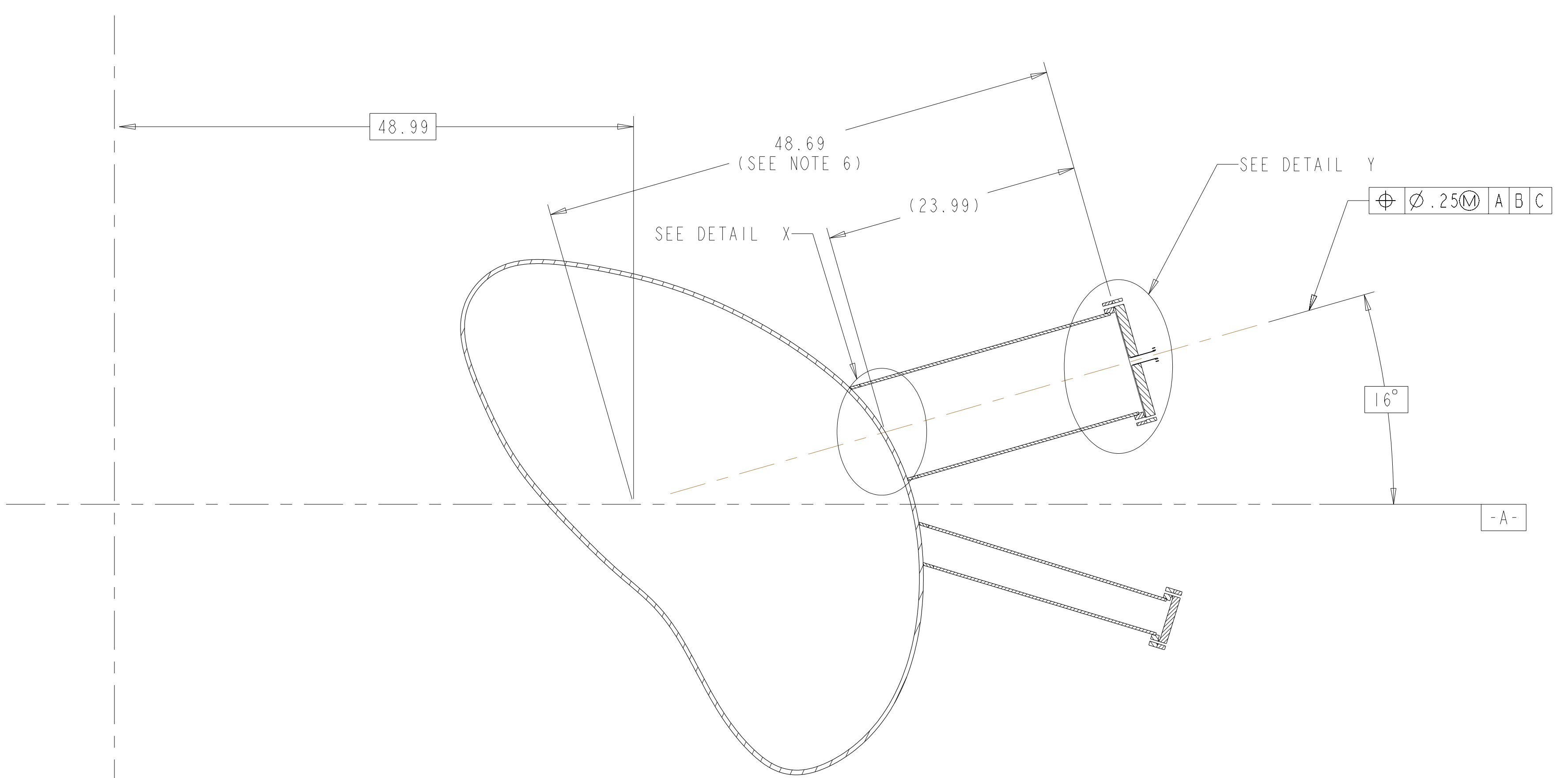

TYPICAL PORT 10A AND 10B  
SECTION PORT10-PORT10

**Rev 2-e: ECN-5021 (RFD-12-017) approved alternate methods for welding the port extensions to the VVSA (See ECN-5021 for details). - Only applicable to VVSA #3 - VVSA #1 and #2 covered by NCR 19464.**

**RELEASED FOR  
FABRICATION / INSTALLATION**  
PPPL Drafting:

<b>UT-BATTELLE</b>		Oak Ridge National Laboratory managed for the DEPARTMENT OF ENERGY under U.S. GOVERNMENT contract DE-AC05-00OR22725 UT-BATTELLE, LLC. Oak Ridge, Tennessee	
PROJECT NAME			
NATIONAL COMPACT STELLARATOR EXPERIMENT			
VACUUM VESSEL			
PERIOD INSPECTION AND LEAK CHECK			
ASSEMBLY			
VERSION NO.	PLANT	BLDG	FL
5	X-10	5700	3
RELEASE LEVEL			
Fabrication			
SHT OF	TYPE	CLASS	
11 19	A	U	
SE120-004			REV
			2

H  
G  
F  
E  
D  
C  
B  
A

SE120-004

FOR PARTS LIST AND NOTES SEE SHEET 1.

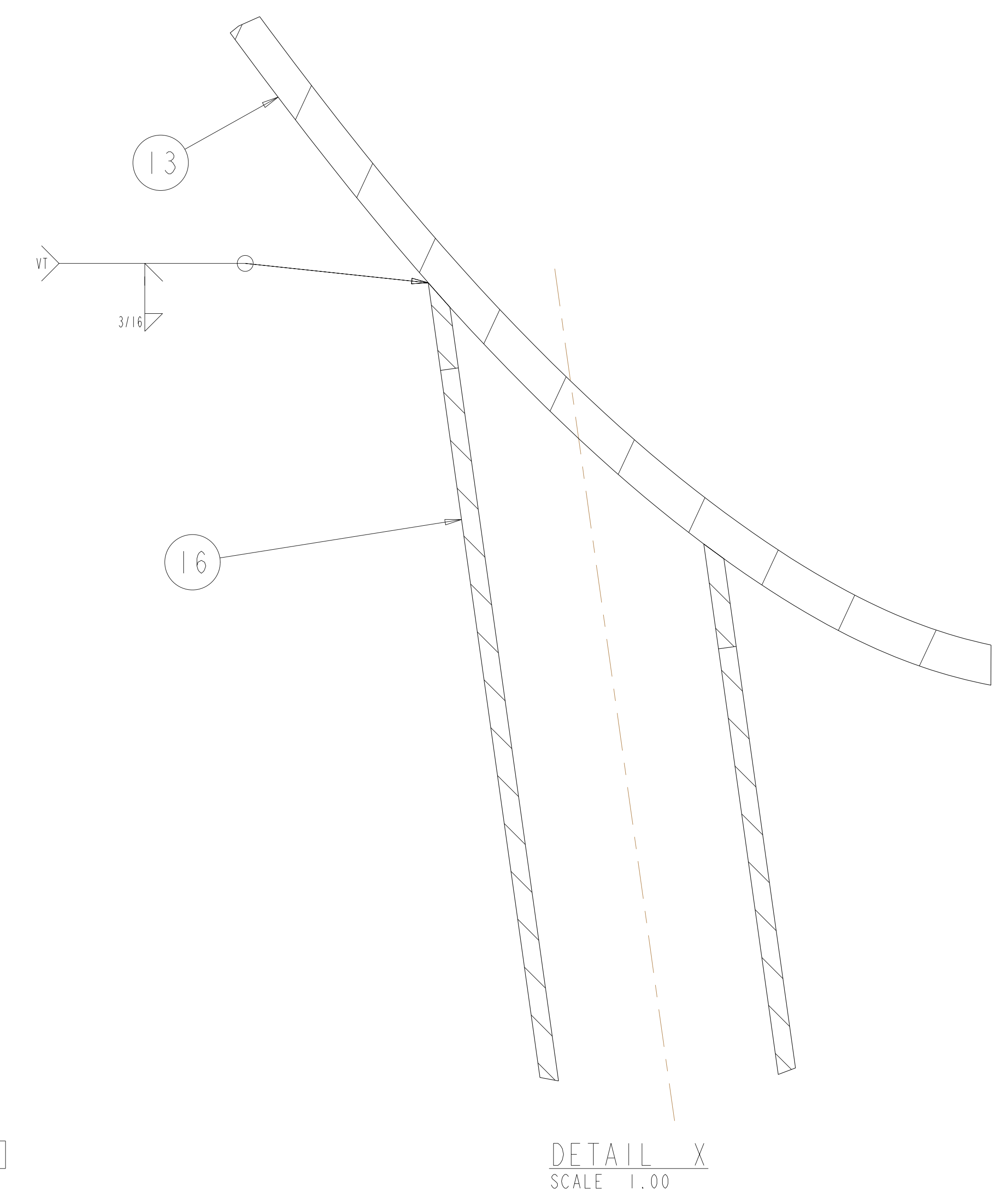
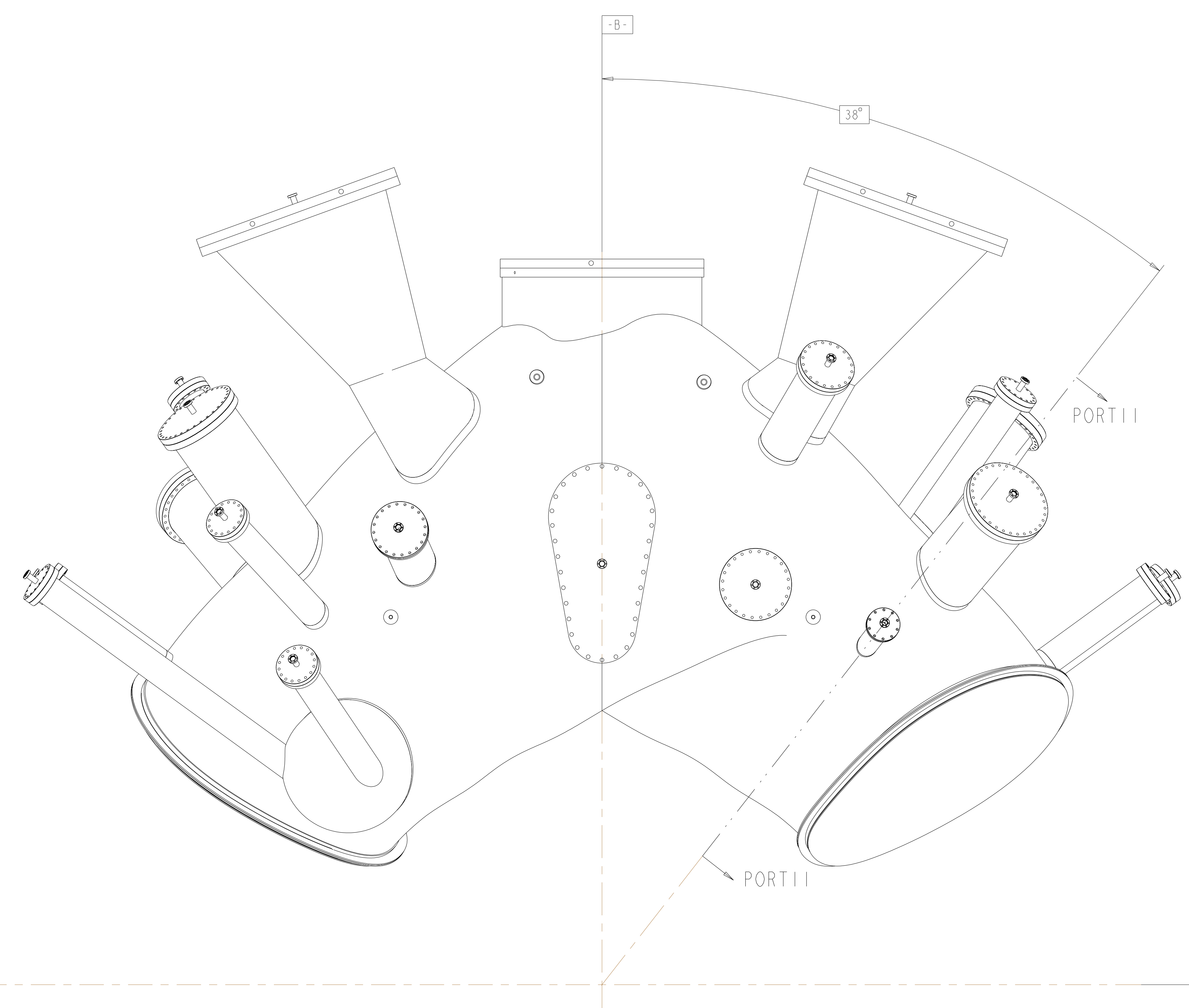

BOTTOM VIEW

**Rev 2-e: ECN-5021 (RFD-12-017) approved alternate methods for welding the port extensions to the VVSA (See ECN-5021 for details). - Only applicable to VVSA #3 - VVSA #1 and #2 covered by NCR 19464.**

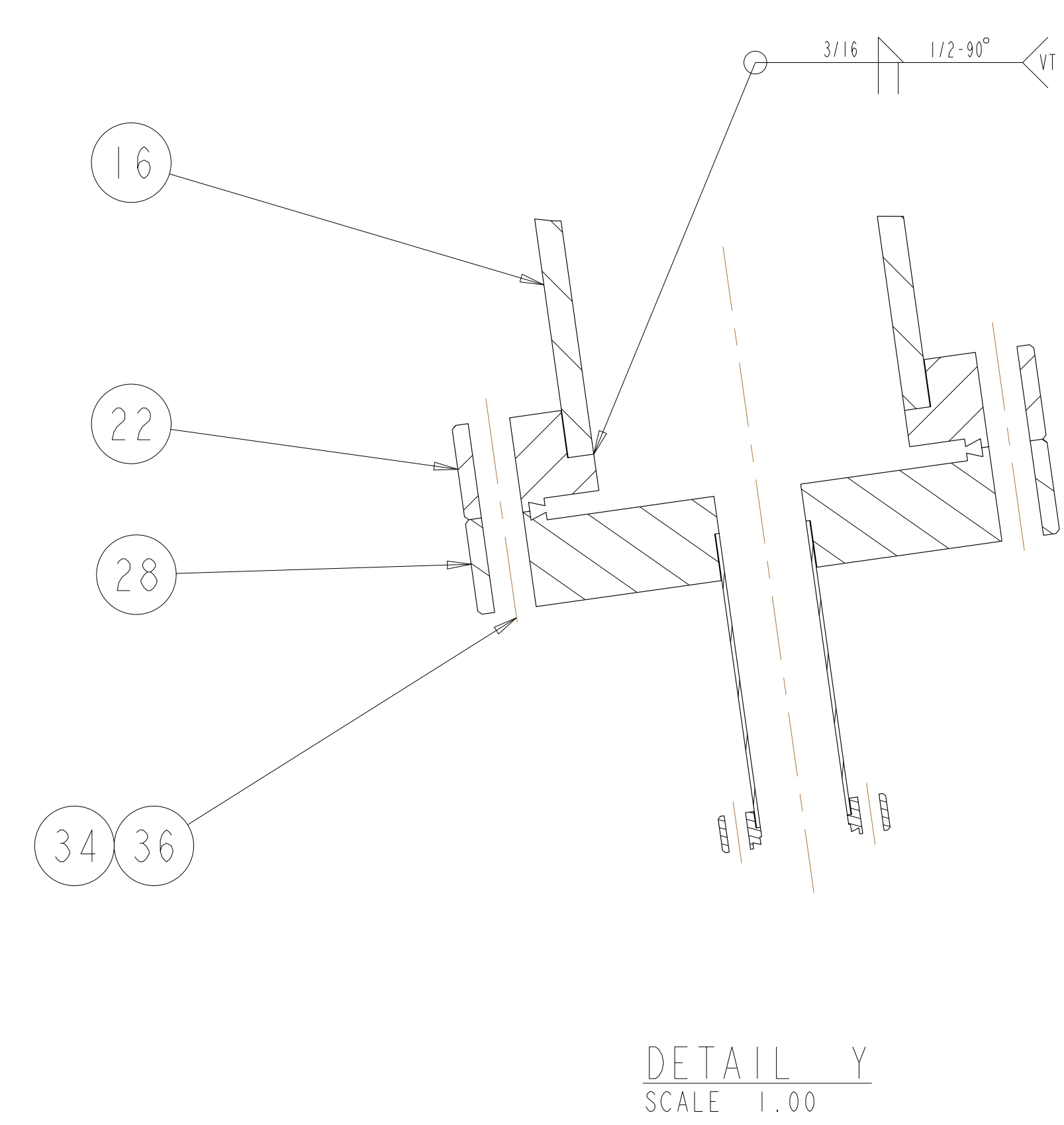
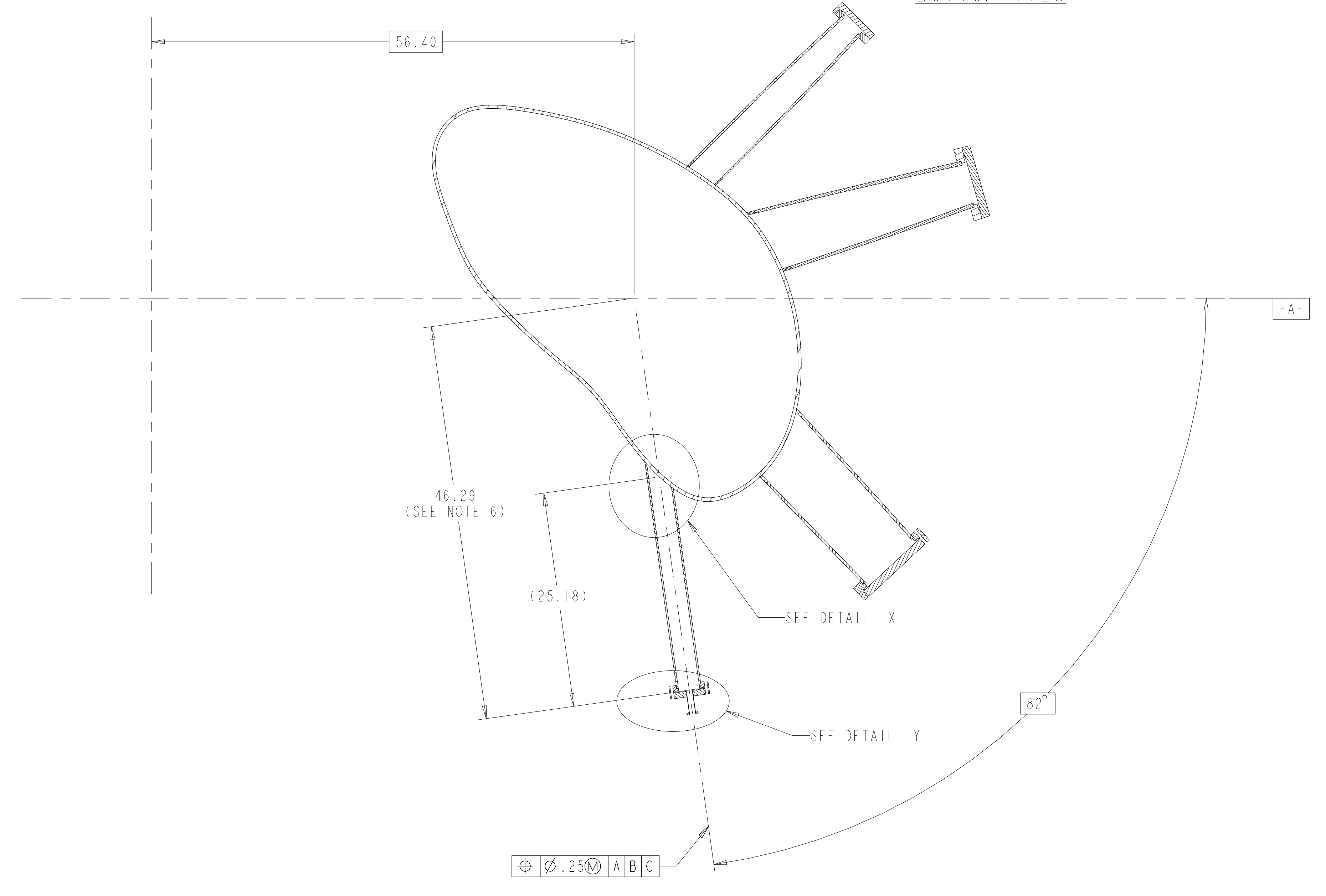

TYPICAL PORT IIA AND IIB SECTION PORT IIA-PORT IIB

**RELEASED FOR FABRICATION / INSTALLATION**  
 PPPL Drafting:

UT-BATTELLE		Oak Ridge National Laboratory managed for the DEPARTMENT OF ENERGY under U.S. GOVERNMENT contract DE-AC05-00OR22725 UT-BATTELLE, LLC, Oak Ridge, Tennessee						
PROJECT NAME								
NATIONAL COMPACT STELLARATOR EXPERIMENT								
VACUUM VESSEL								
PERIOD INSPECTION AND LEAK CHECK								
ASSEMBLY								
VERSION NO.	PLANT	BLDG	FL	SHT OF	TYPE	CLASS		
5	X-10	5700	3	12 19	A	U		
RELEASE LEVEL		SE120-004					REV	
Fabrication							2	

H  
G  
F  
E  
D  
C  
B  
A

SE120-004

FOR PARTS LIST AND NOTES SEE SHEET 1.

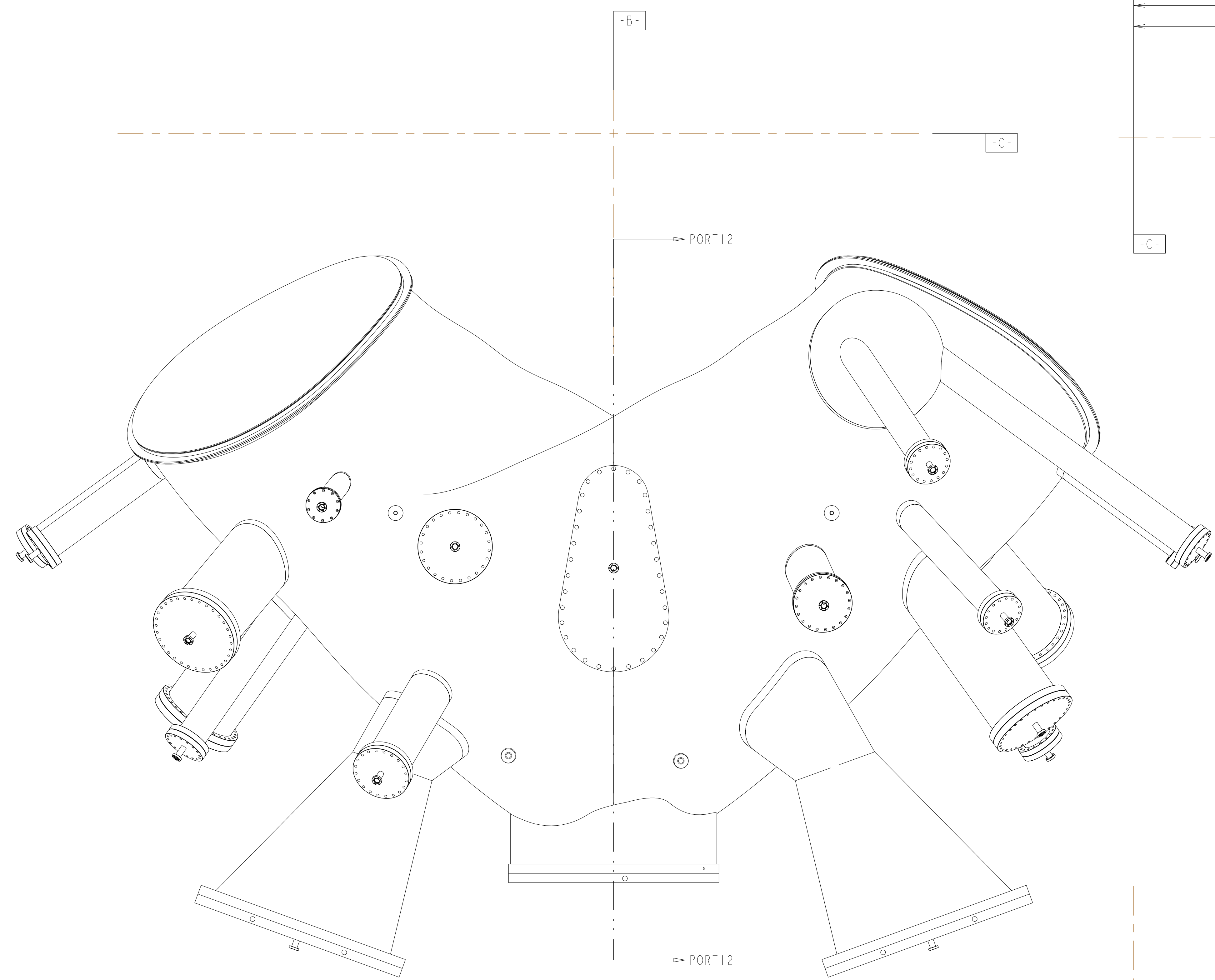

TOP VIEW

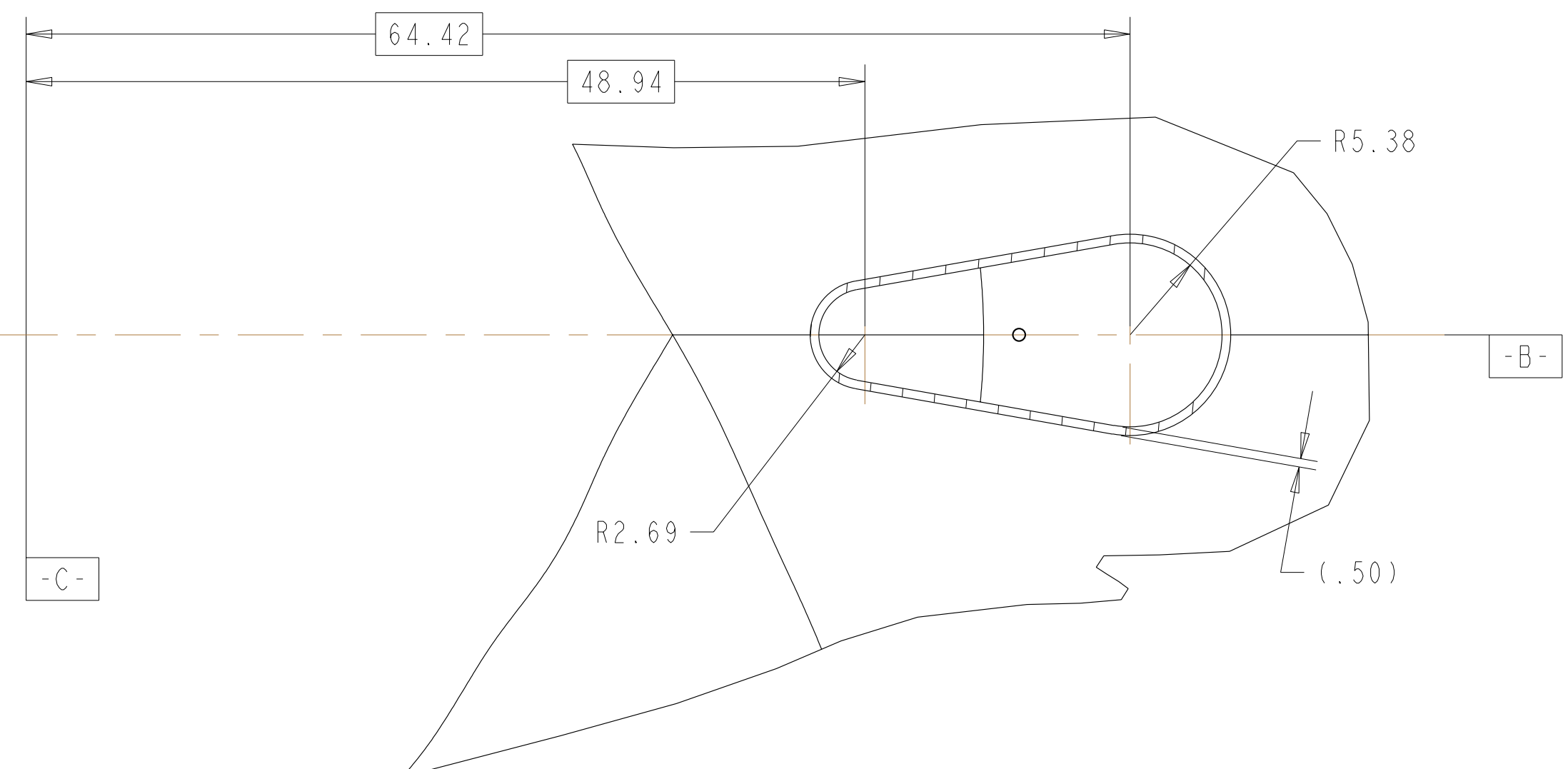

SECTION J-J  
 TYP TOP AND BOTTOM

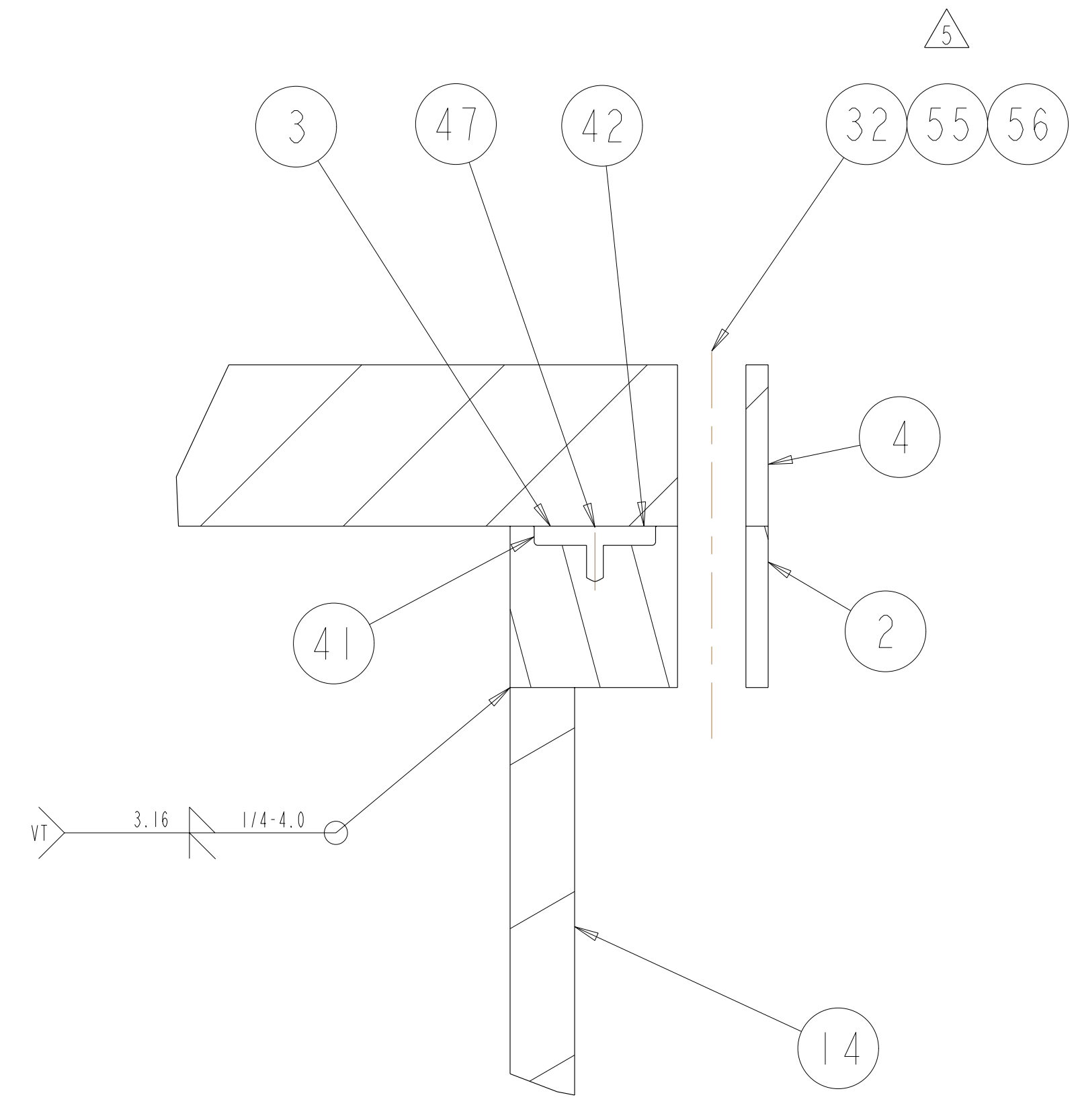

DETAIL Y  
 SCALE 1.00

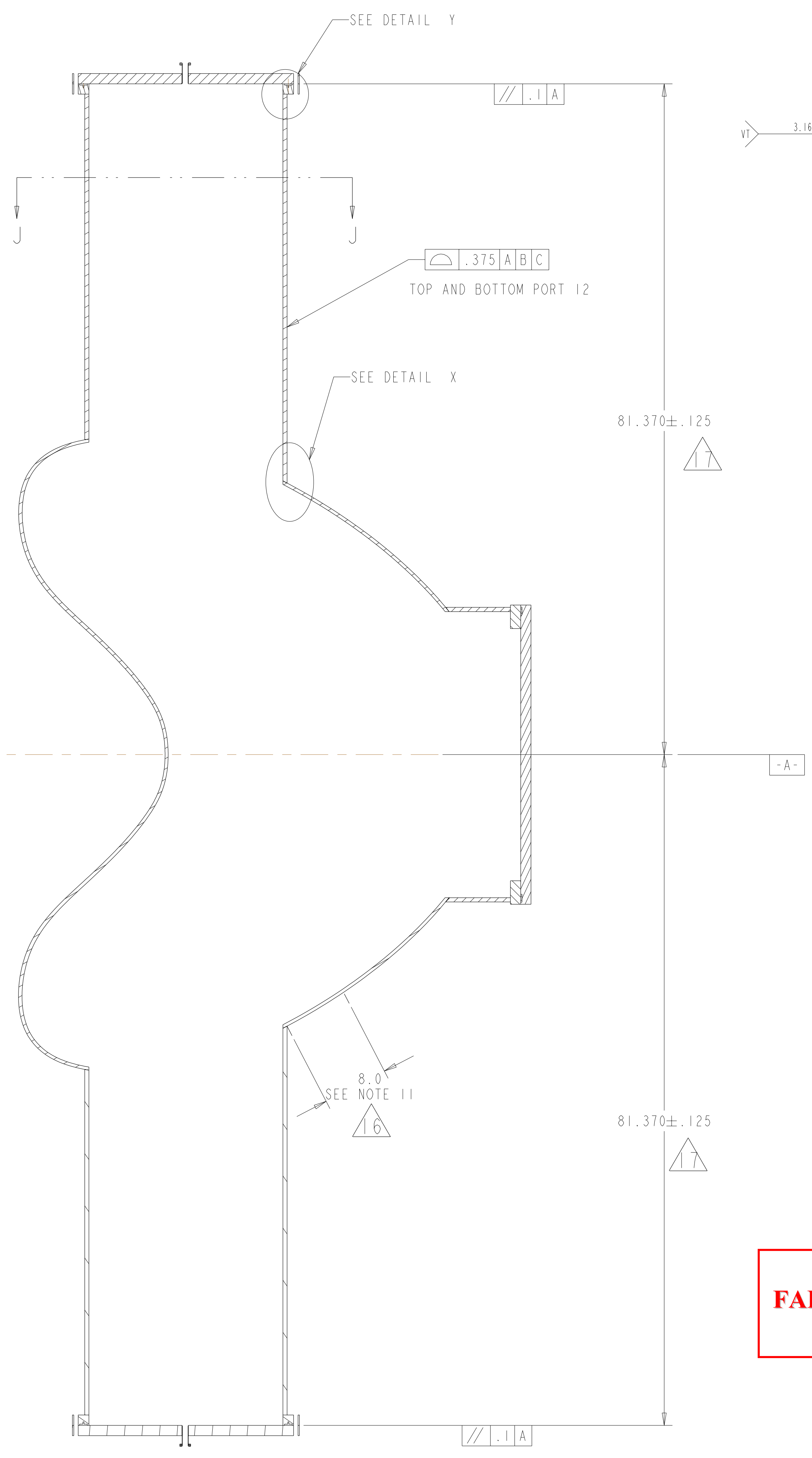

SECTION PORT12-PORT12

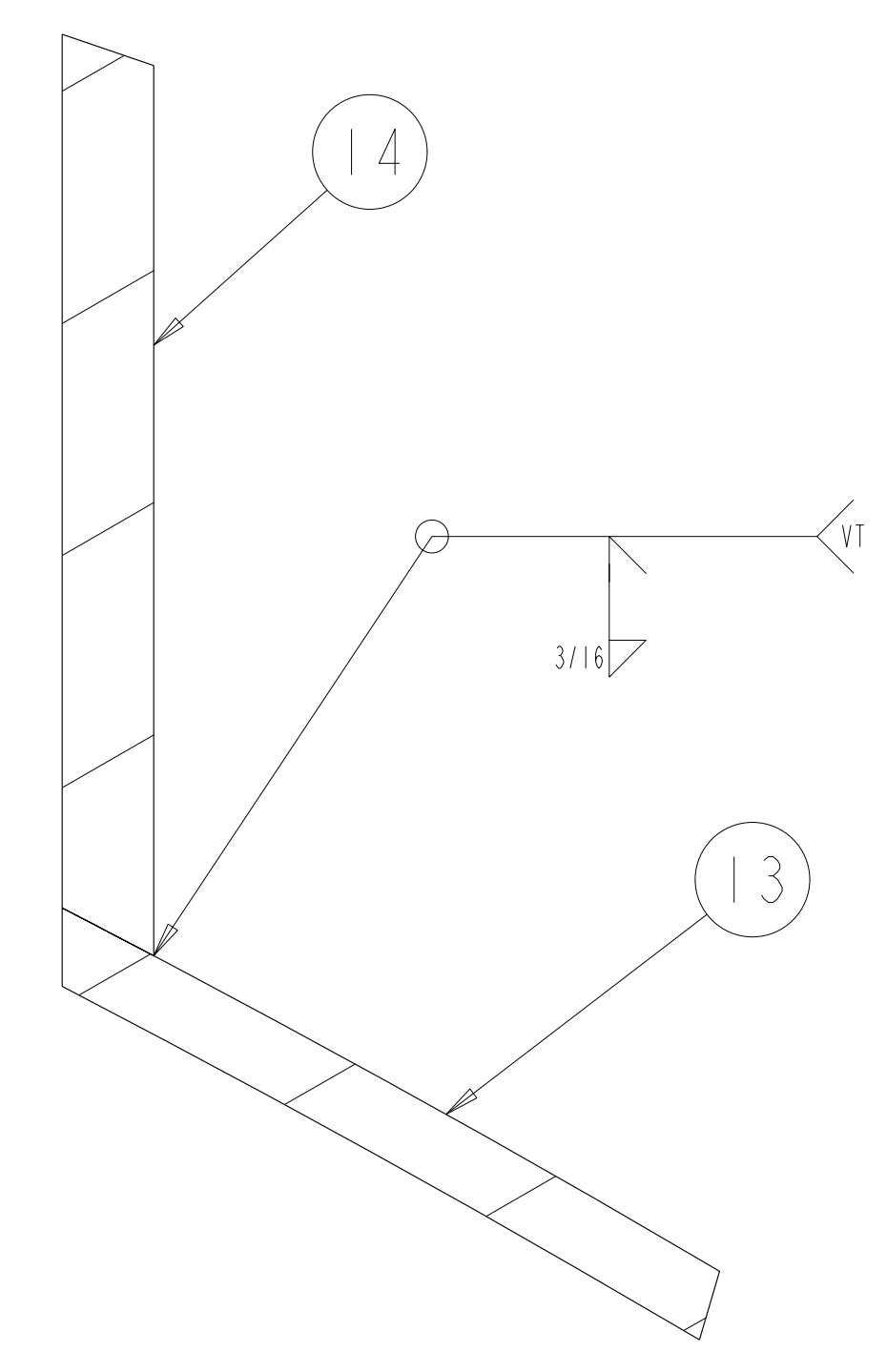

DETAIL X  
 SCALE 1.00

**Rev 2-e: ECN-5021 (RFD-12-017) approved alternate methods for welding the port extensions to the VVSA (See ECN-5021 for details). - Only applicable to VVSA #3 - VVSA #1 and #2 covered by NCR 19464.**

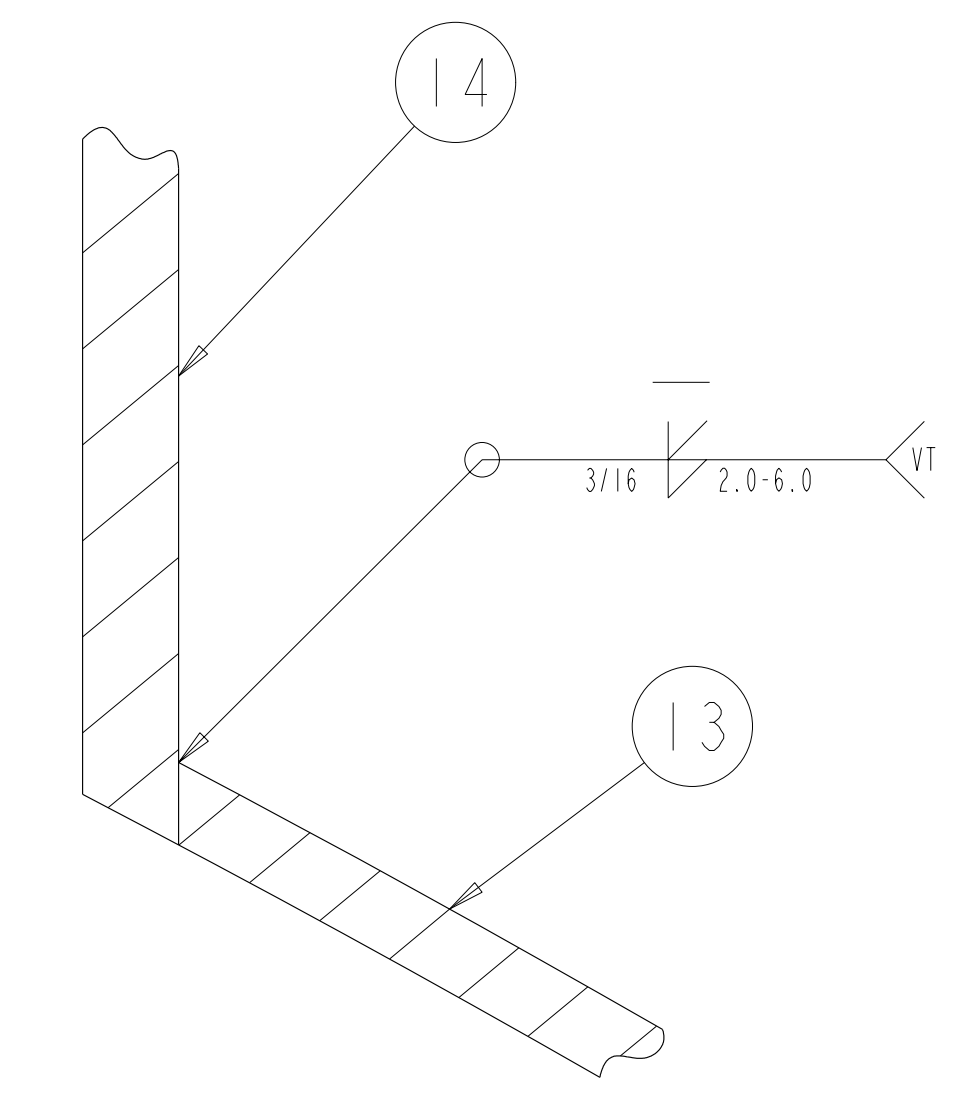

OPTIONAL WELD DETAIL

**RELEASED FOR FABRICATION / INSTALLATION**  
 PPPL Drafting:

UT-BATTELLE		Oak Ridge National Laboratory managed for the DEPARTMENT OF ENERGY under U.S. GOVERNMENT contract DE-AC05-00OR22725 UT-BATTELLE, LLC, Oak Ridge, Tennessee	
PROJECT NAME			
NATIONAL COMPACT STELLARATOR EXPERIMENT			
VACUUM VESSEL			
PERIOD INSPECTION AND LEAK CHECK ASSEMBLY			
VERSION NO.	PLANT	BLDG	FL
5	X-10	5700	3
RELEASE LEVEL			
Fabrication			
SHT OF	TYPE	CLASS	
13	A	U	
SE120-004			REV 2

H  
G  
F  
E  
D  
C  
B  
A

FOR PARTS LIST AND NOTES SEE SHEET 1.

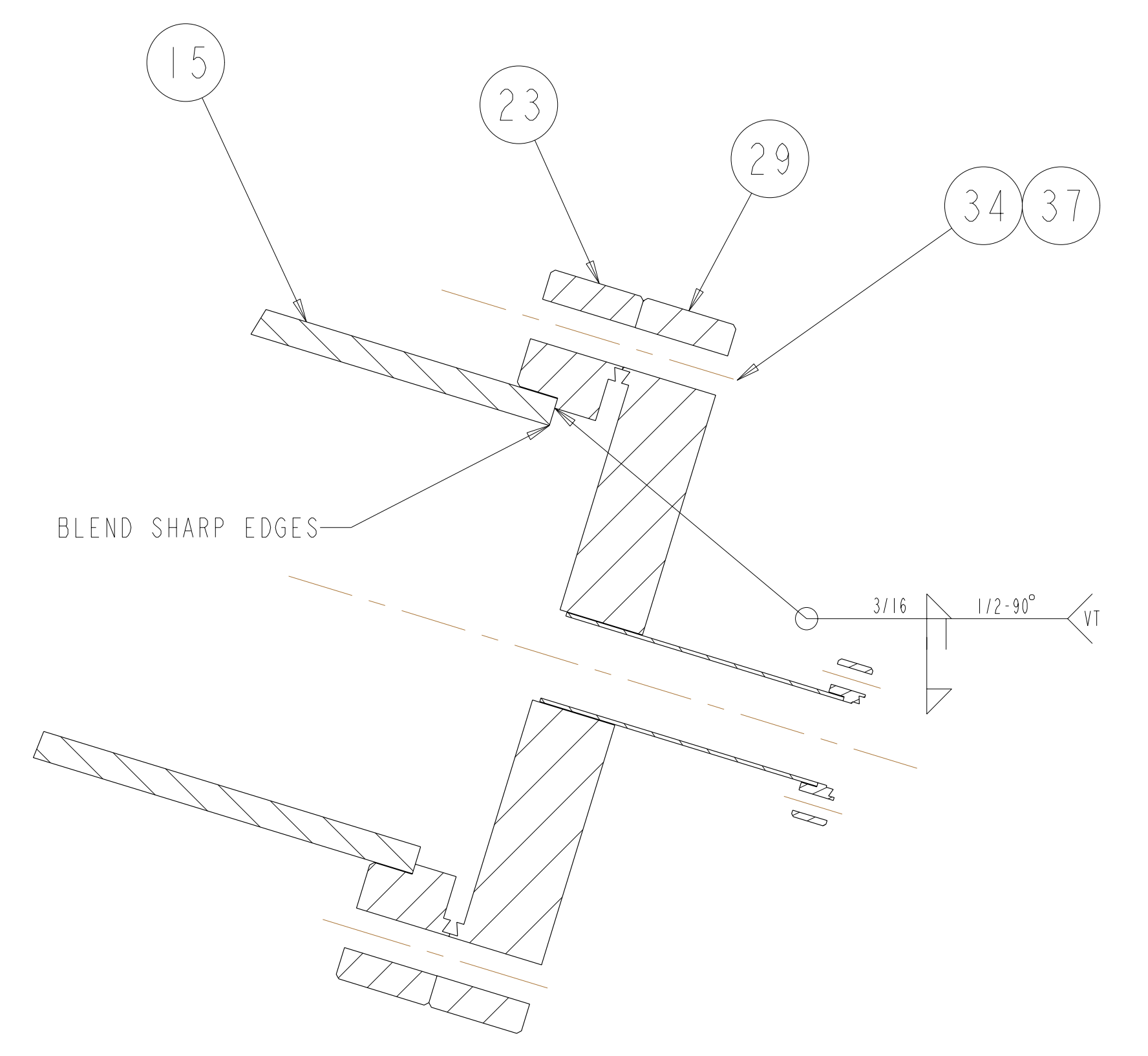
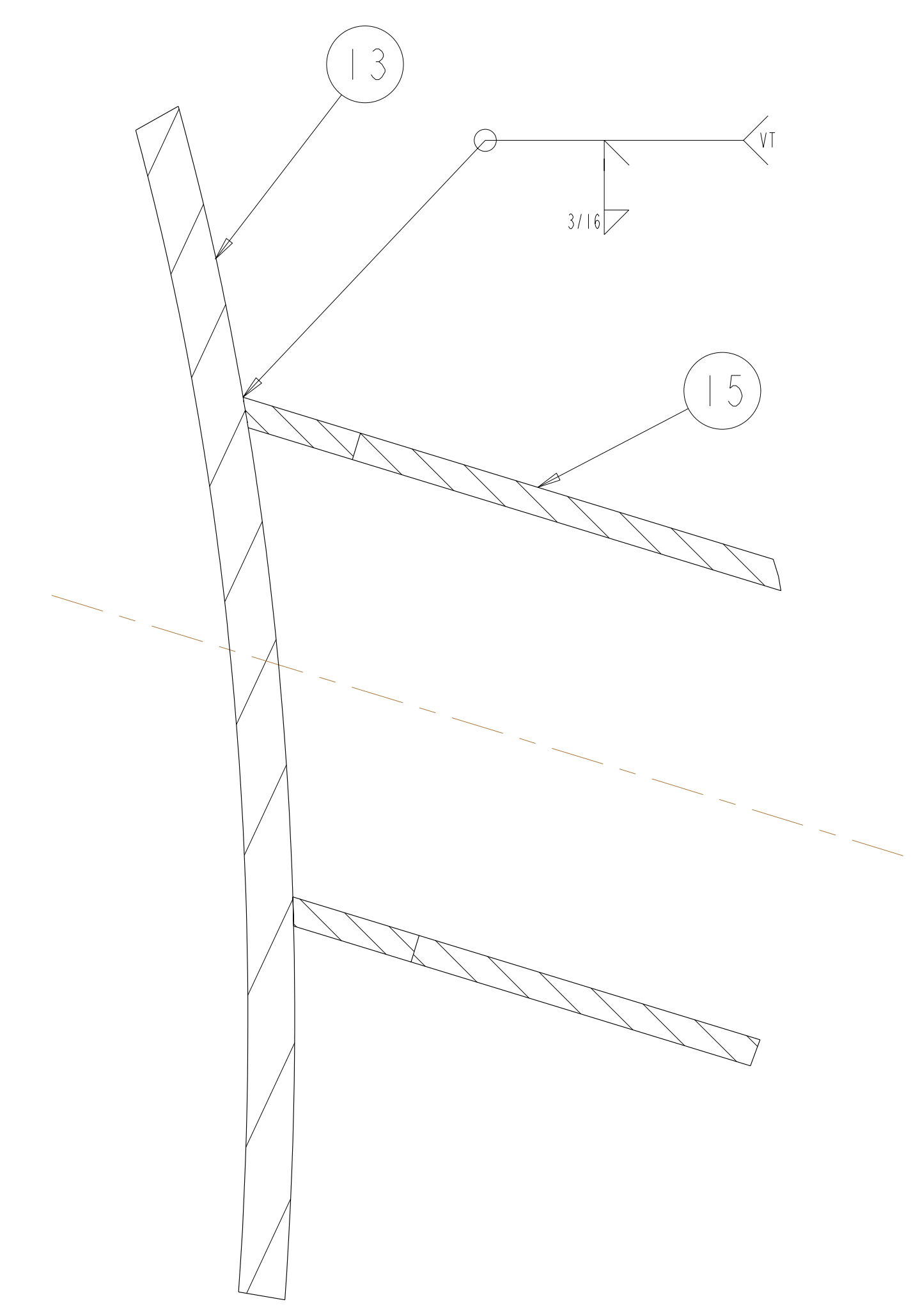
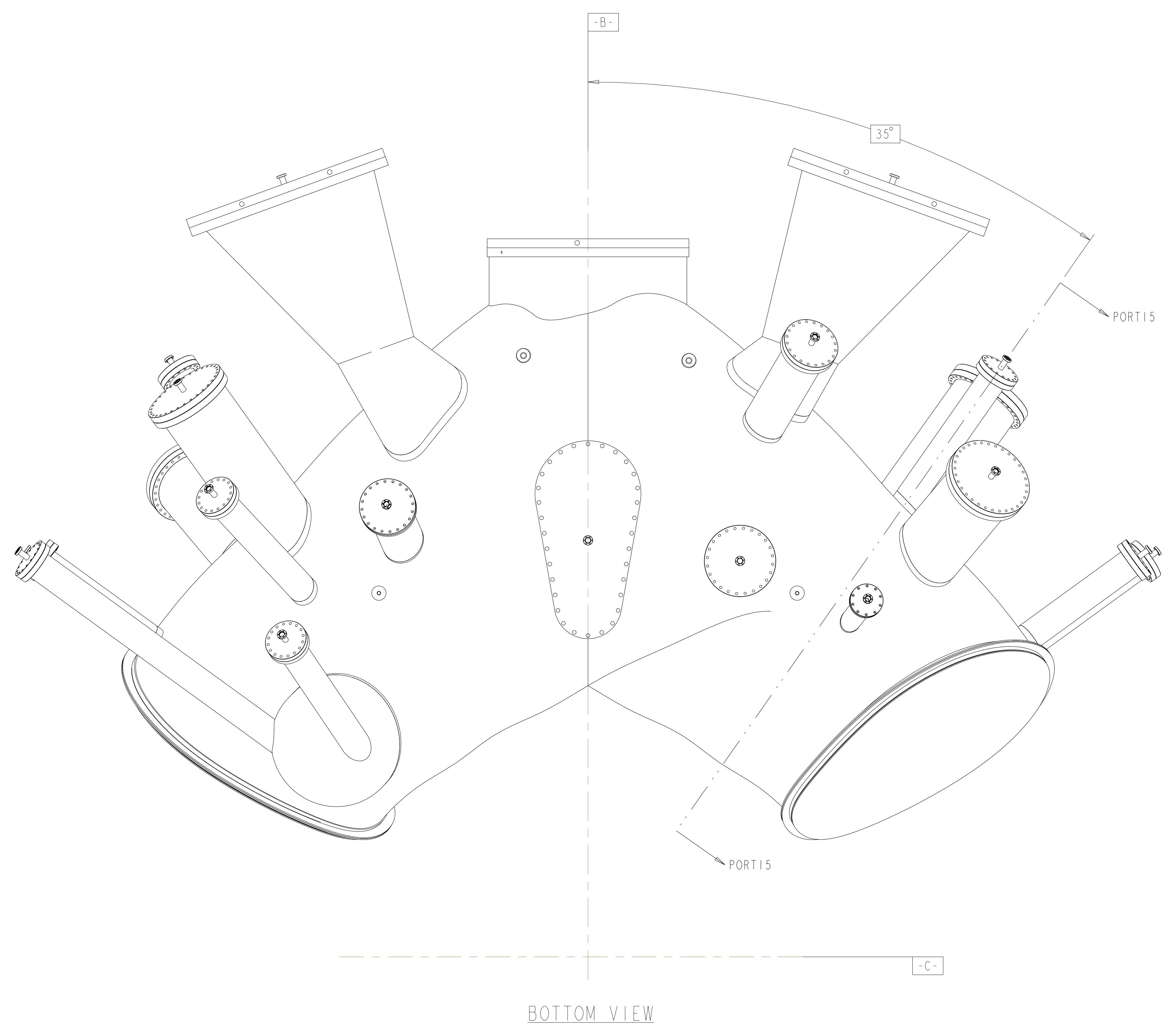

**Rev 2-e: ECN-5021 (RFD-12-017) approved alternate methods for welding the port extensions to the VVSA (See ECN-5021 for details). - Only applicable to VVSA #3 - VVSA #1 and #2 covered by NCR 19464.**

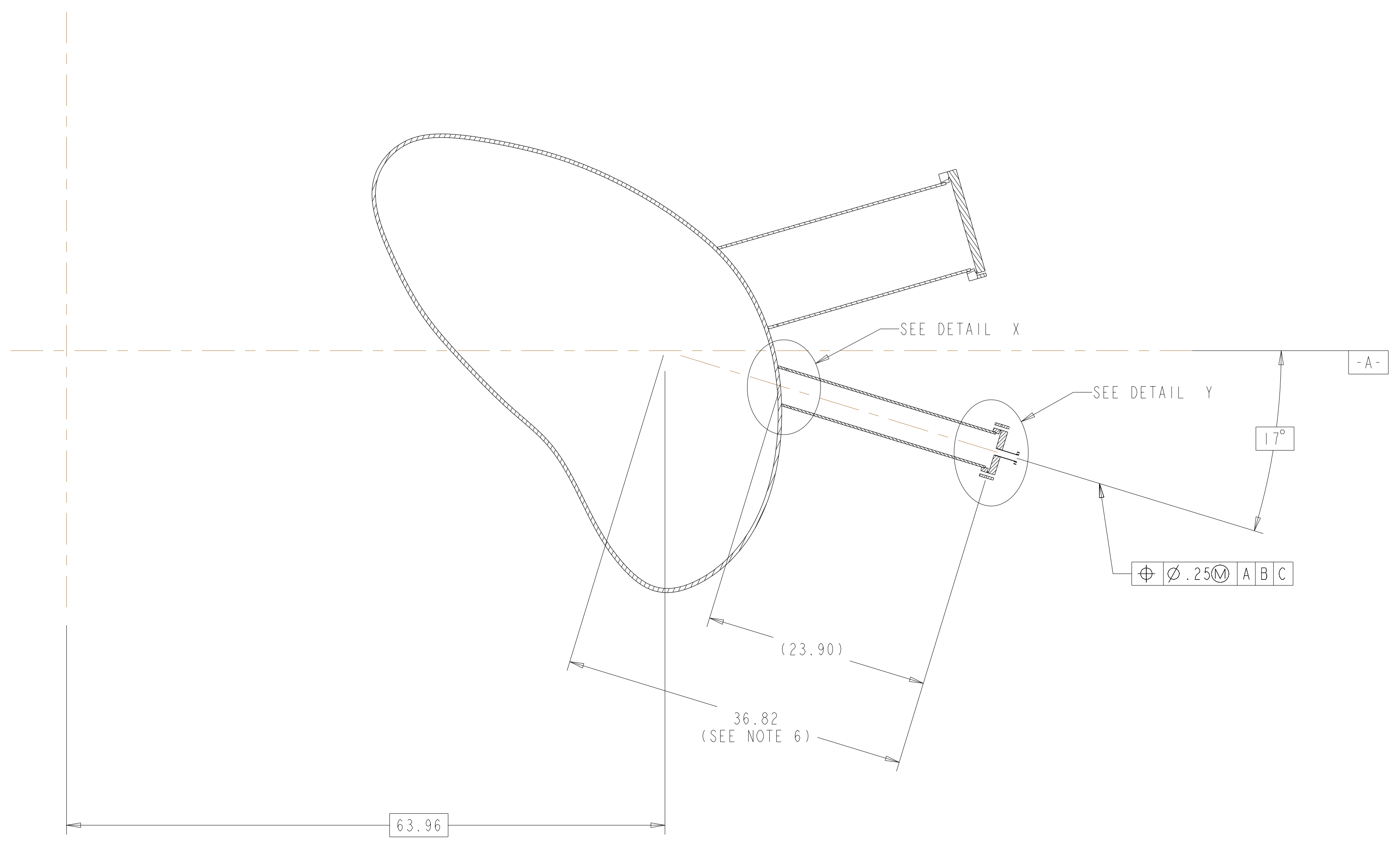

**RELEASED FOR FABRICATION / INSTALLATION**  
 PPPL Drafting:

<b>UT-BATTELLE</b>		Oak Ridge National Laboratory managed for the DEPARTMENT OF ENERGY under U.S. GOVERNMENT contract DE-AC05-00OR22725 UT-BATTELLE, LLC, Oak Ridge, Tennessee	
PROJECT NAME			
NATIONAL COMPACT STELLARATOR EXPERIMENT			
VACUUM VESSEL			
PERIOD INSPECTION AND LEAK CHECK ASSEMBLY			
VERSION NO.	PLANT	BLDG	FL
5	X-10	5700	3
RELEASE LEVEL			
Fabrication			
SHT OF	TYPE	CLASS	
14	A	U	
SEI20-004			REV
			2

FOR PARTS LIST AND NOTES SEE SHEET 1

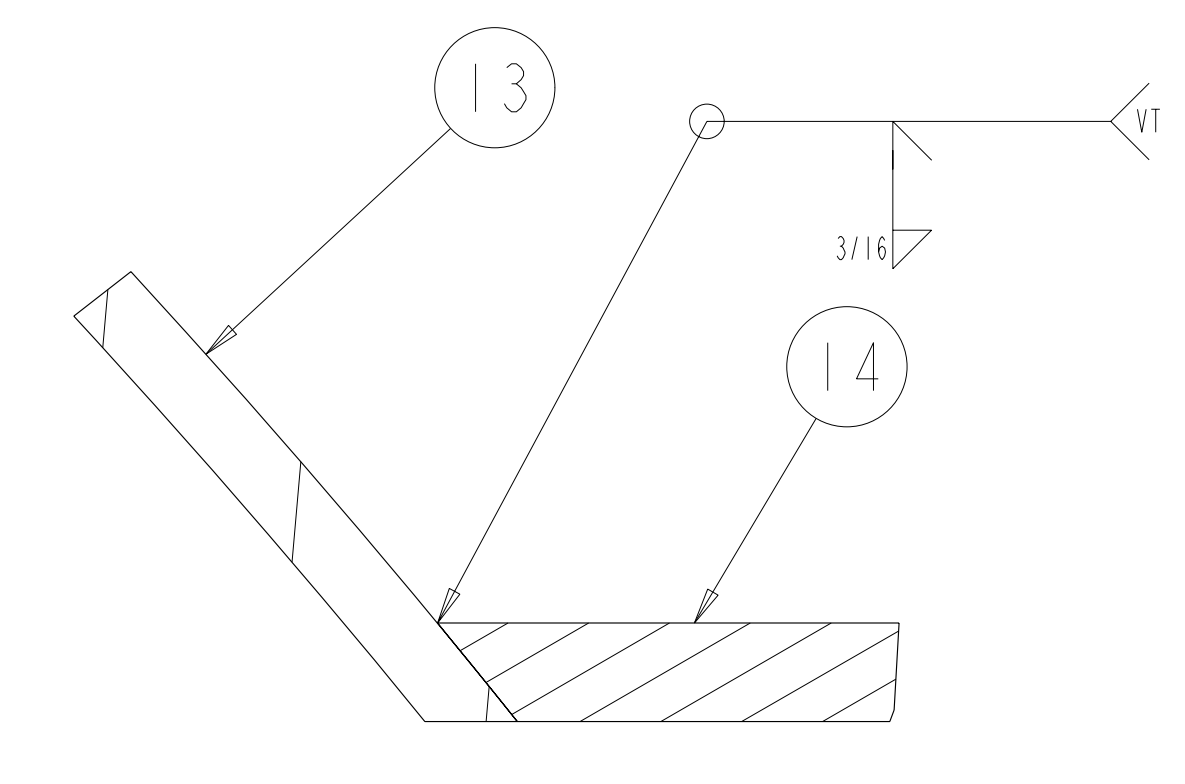
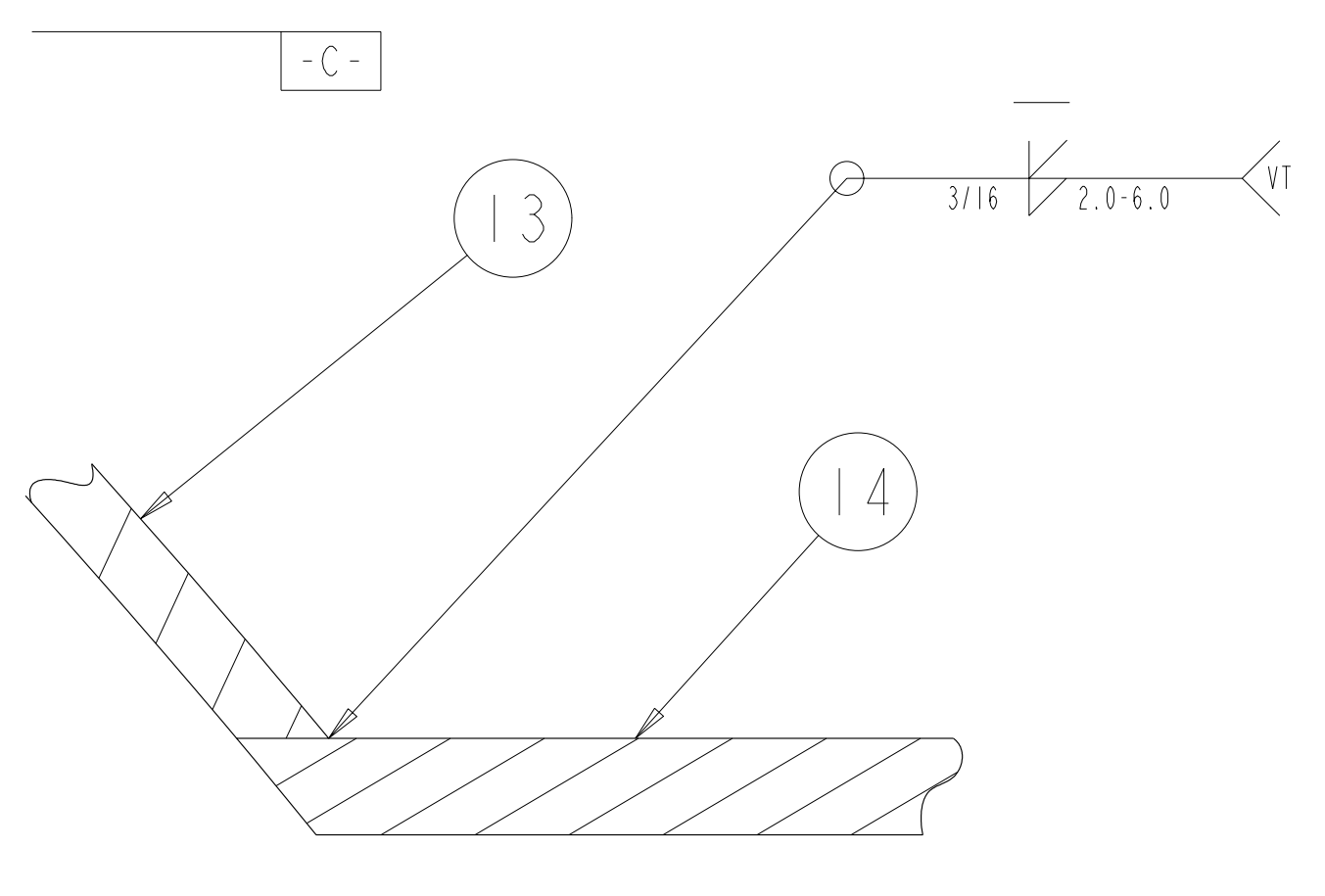
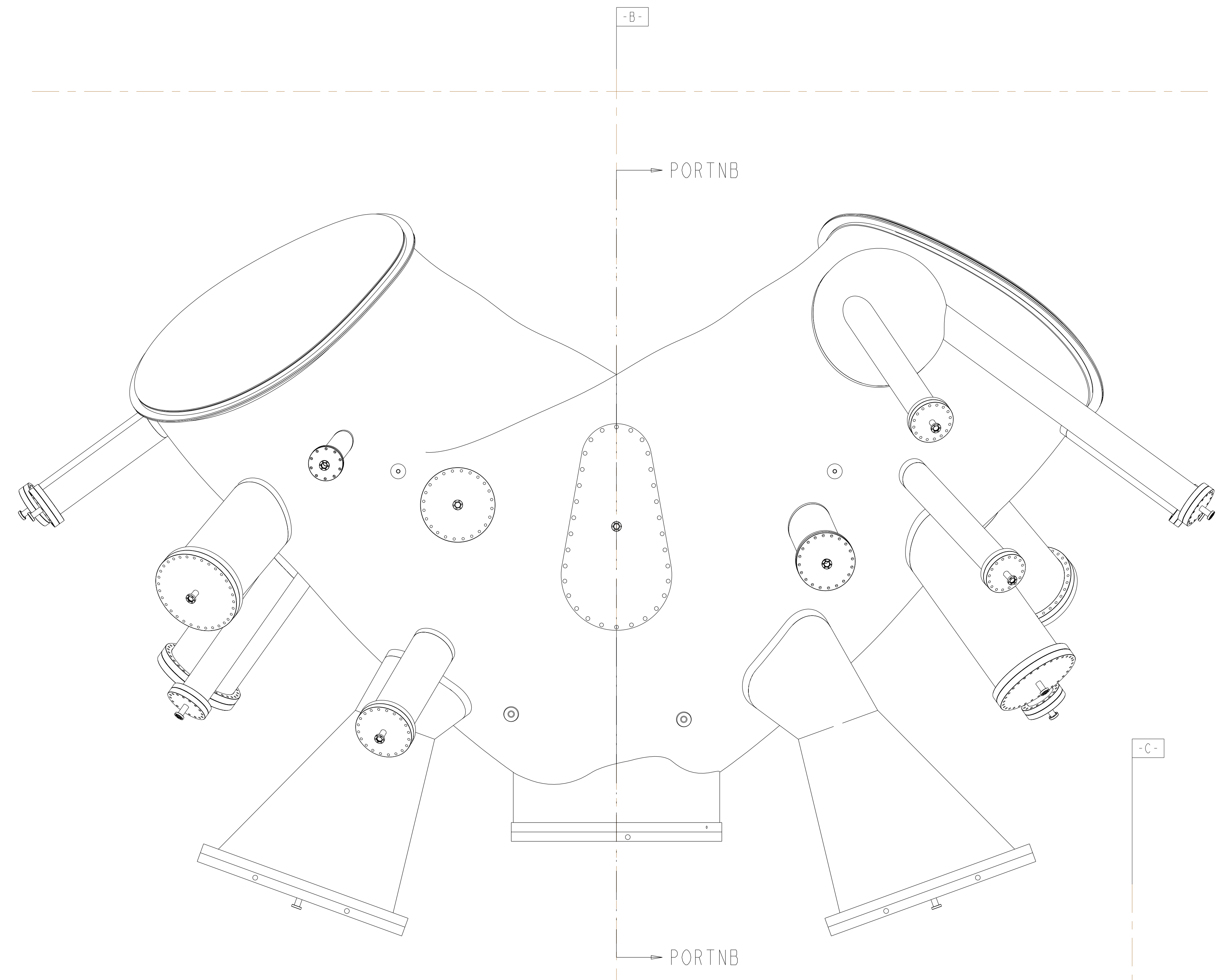

DETAIL X  
SCALE 1.00

OPTIONAL WELD DETAIL

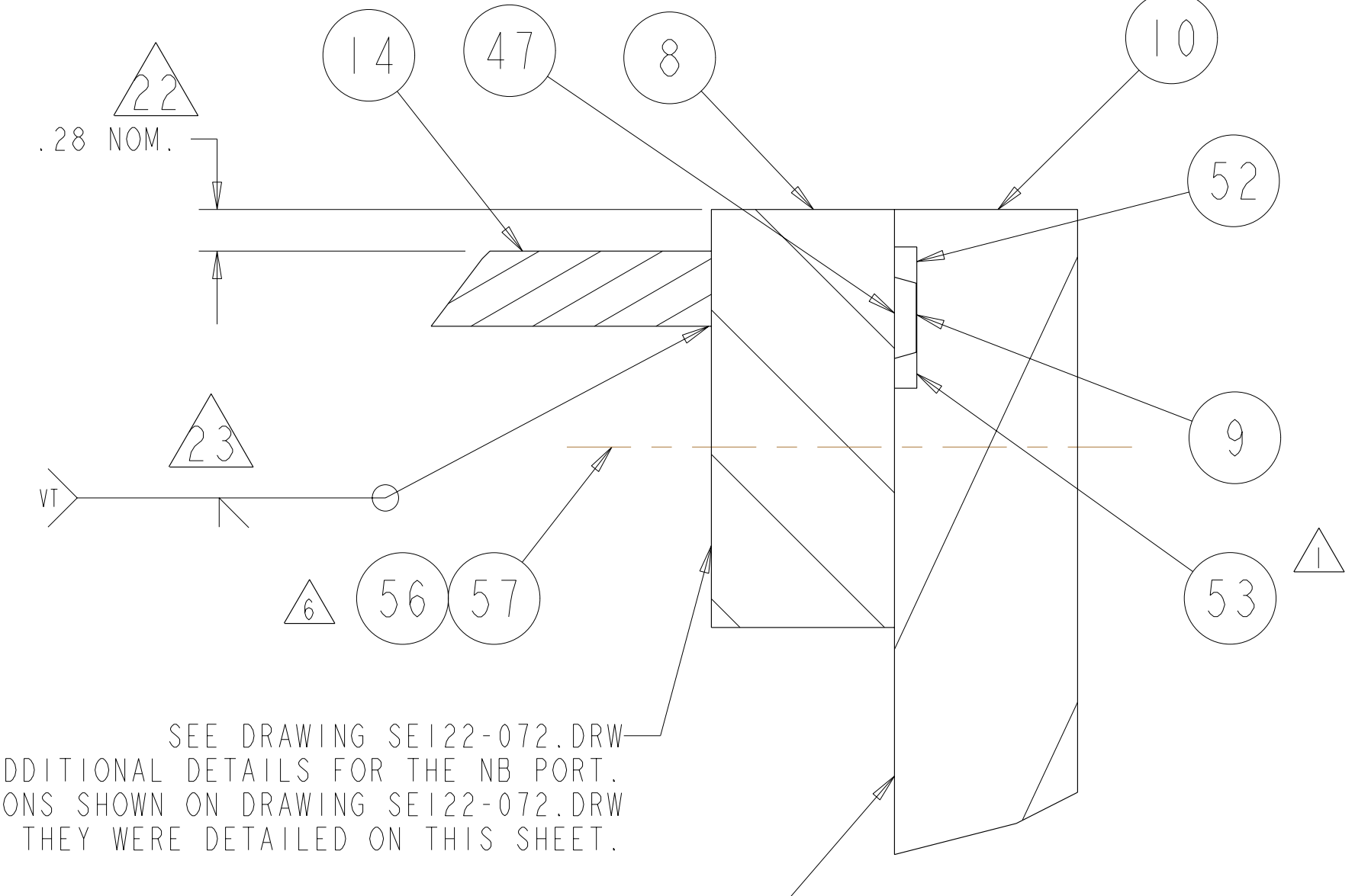

DETAIL Y  
SCALE 1.00

SEE DRAWING SE122-072.DRW FOR ADDITIONAL DETAILS FOR THE NB PORT DIMENSIONS SHOWN ON DRAWING SE122-072.DRW APPLY AS IF THEY WERE DETAILED ON THIS SHEET.

SEE DRAWING SE122-172.DRW FOR ADDITIONAL DETAILS FOR THE NB PORT DIMENSIONS SHOWN ON DRAWING SE122-172.DRW APPLY AS IF THEY WERE DETAILED ON THIS SHEET.

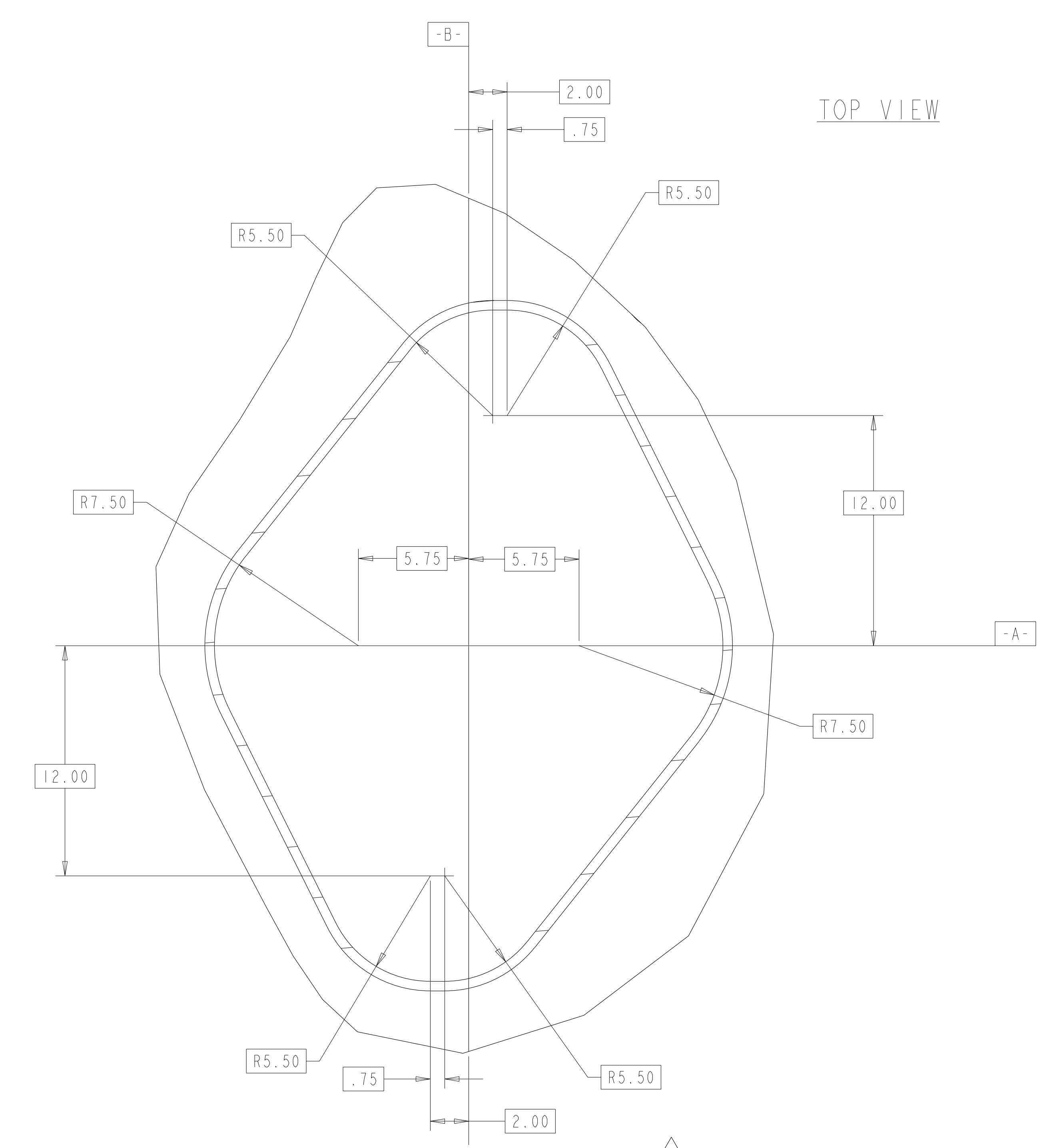

SECTION K-K  
SCALE 0.25

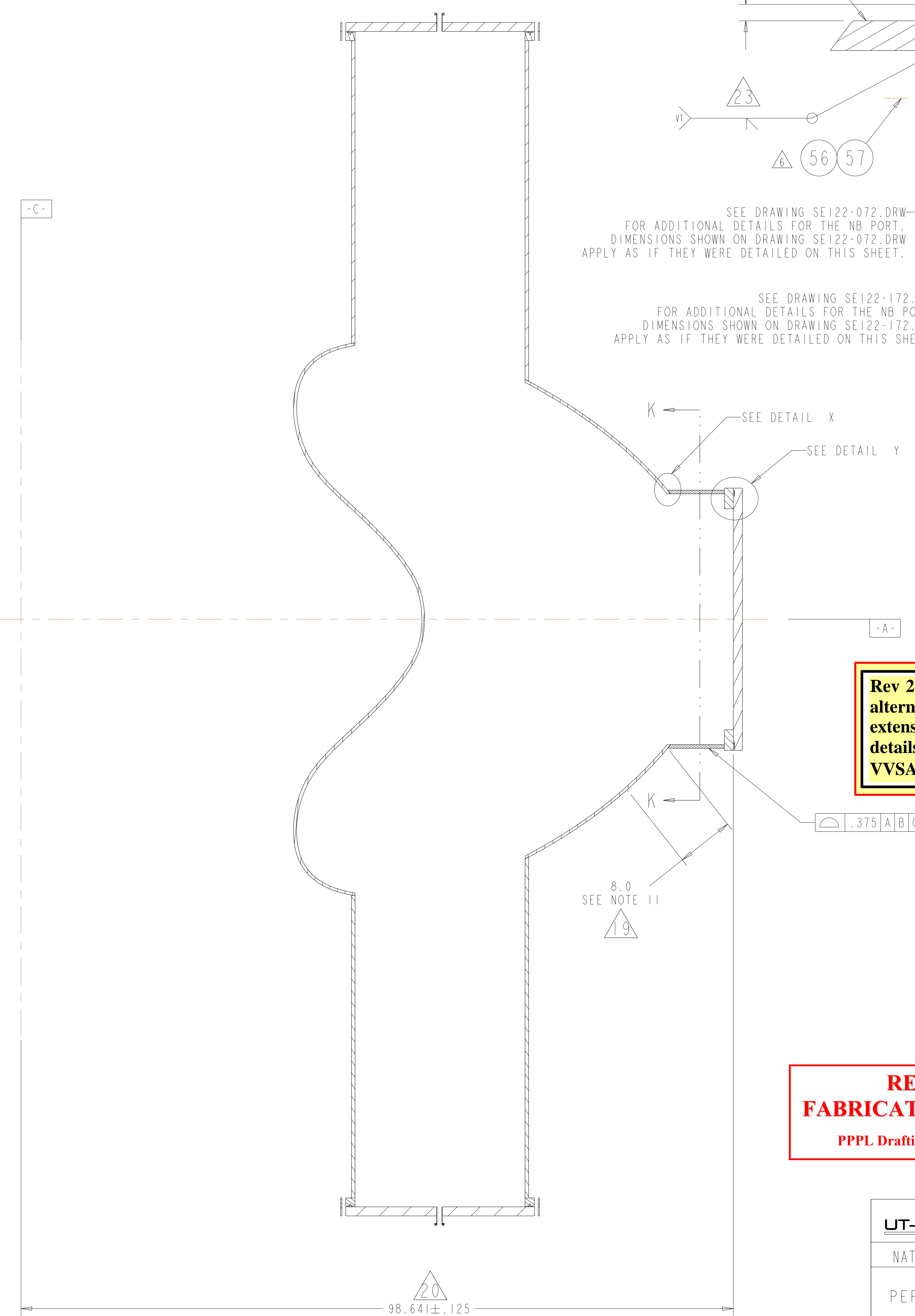

SECTION PORTNB-PORTNB

**Rev 2-e: ECN-5021 (RFD-12-017) approved alternate methods for welding the port extensions to the VVSA (See ECN-5021 for details). - Only applicable to VVSA #3 - VVSA #1 and #2 covered by NCR 19464.**

**RELEASED FOR FABRICATION / INSTALLATION**  
 PPPL Drafting:

UT-BATTELLE						Oak Ridge National Laboratory managed for the DEPARTMENT OF ENERGY under U.S. GOVERNMENT contract DE-AC05-00OR22725 UT-BATTELLE, LLC, Oak Ridge, Tennessee					
NATIONAL COMPACT STELLARATOR EXPERIMENT											
VACUUM VESSEL PERIOD INSPECTION AND LEAK CHECK ASSEMBLY											
VERSION NO.	PLANT	BLDG	FL	SHT OF	TYPE	CLASS					
5	X-10	5700	3	15	A	U					
RELEASE LEVEL	SE120-004										
Fabrication											

H  
G  
F  
E  
D  
C  
B  
A

FOR PARTS LIST AND NOTES SEE SHEET 1.

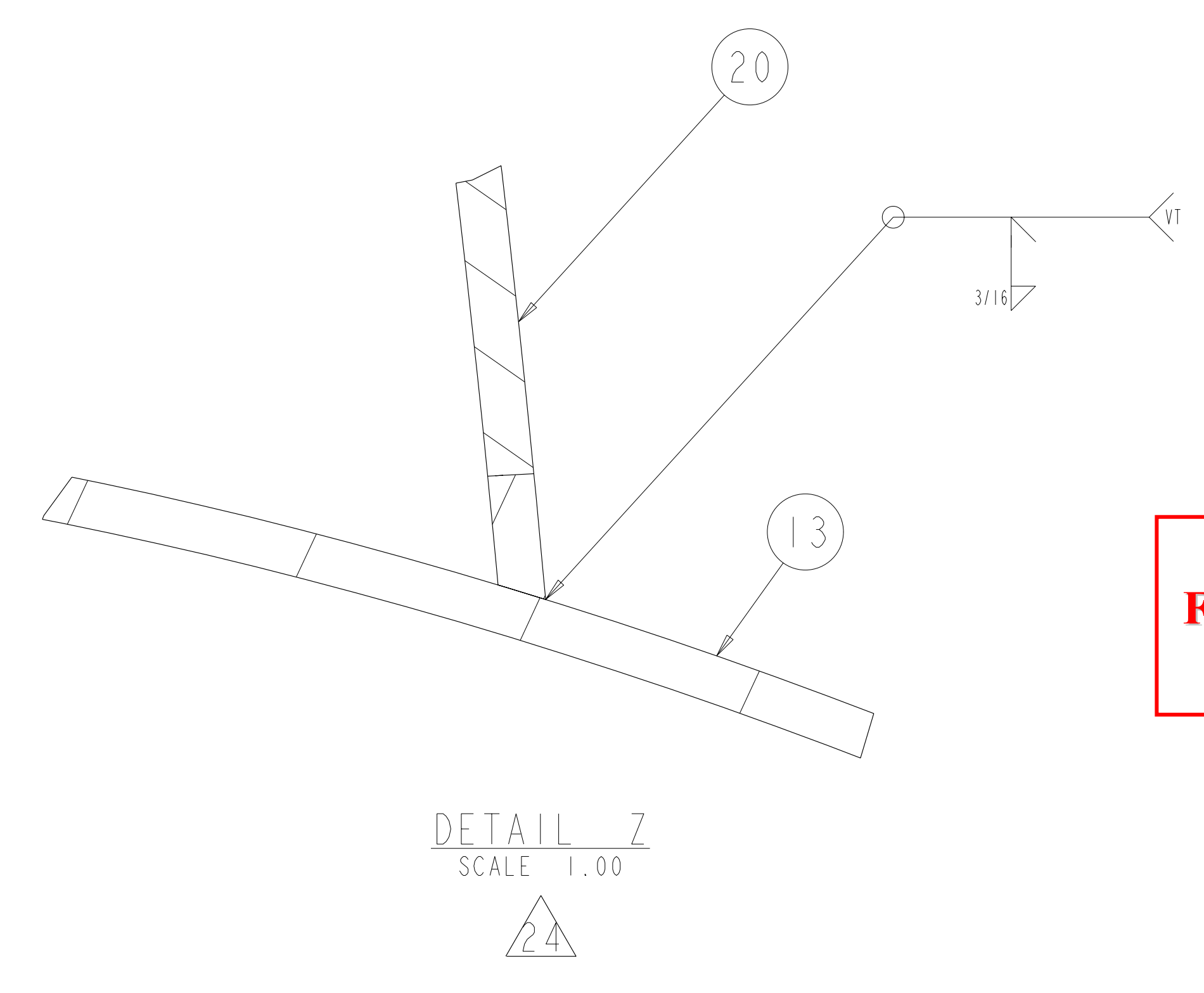
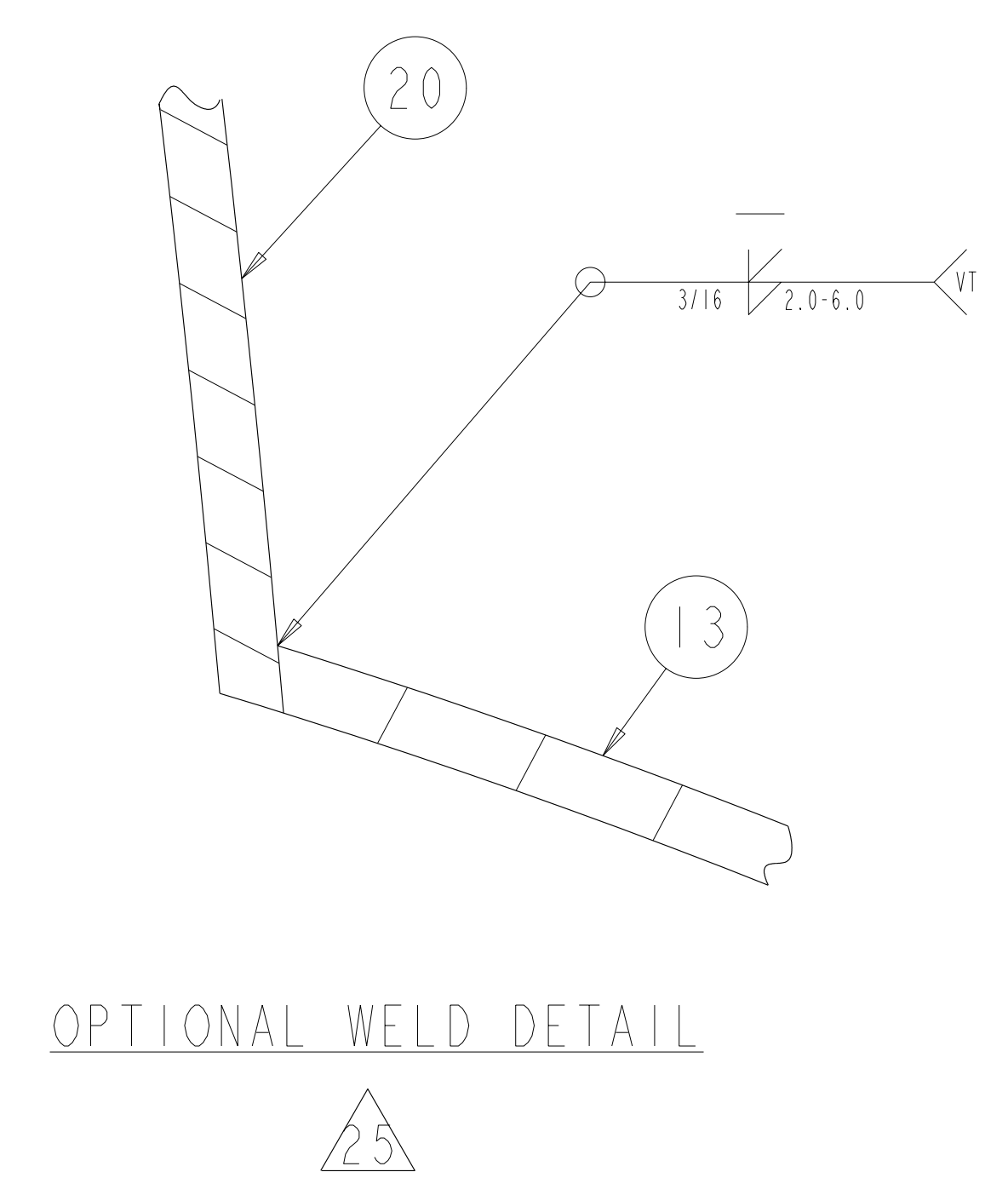
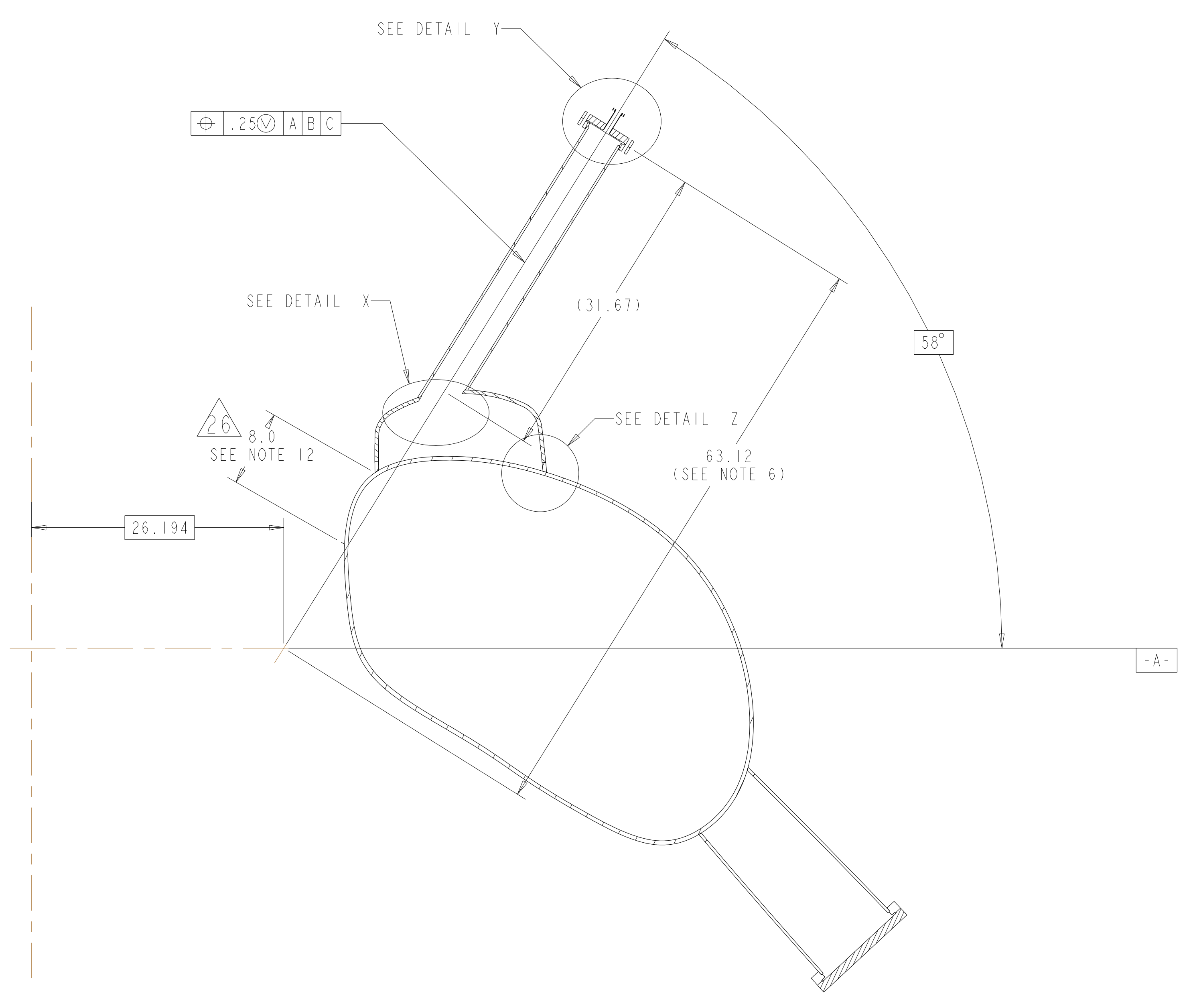
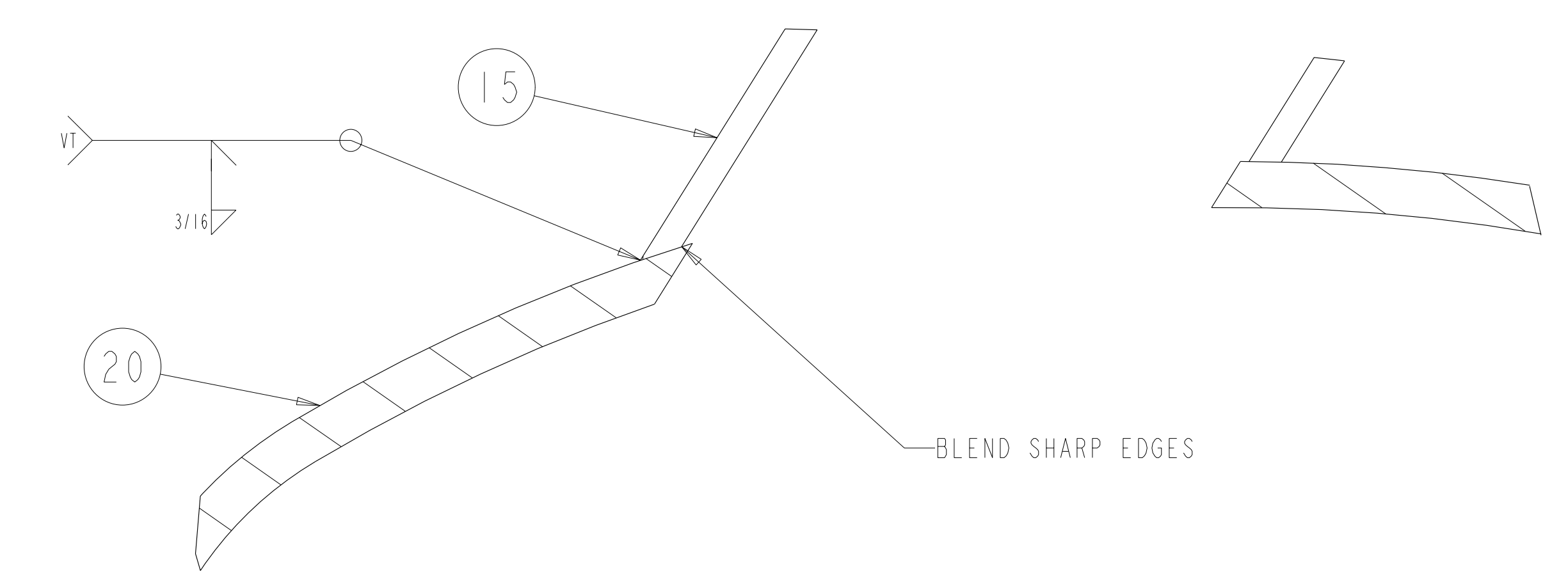
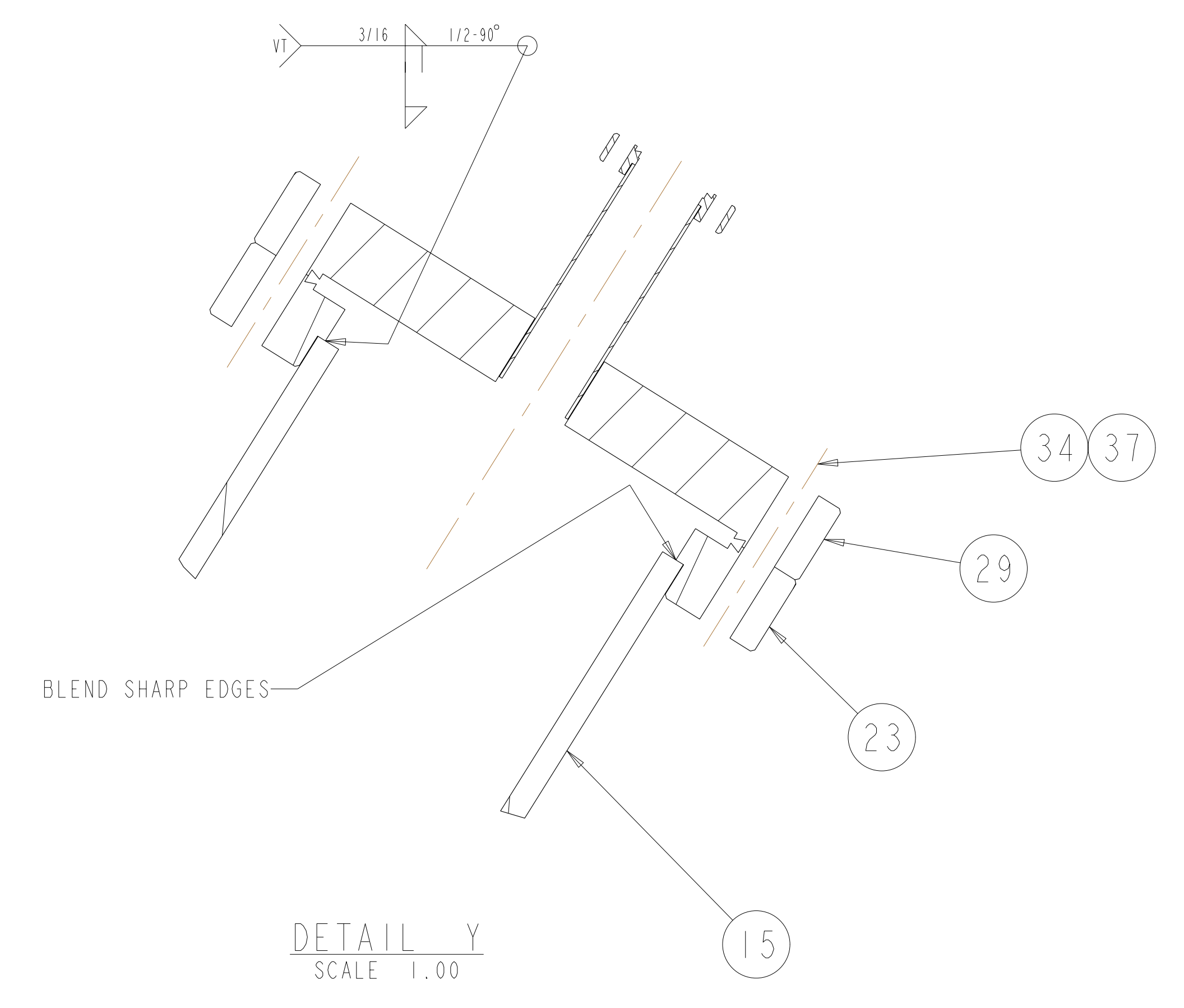
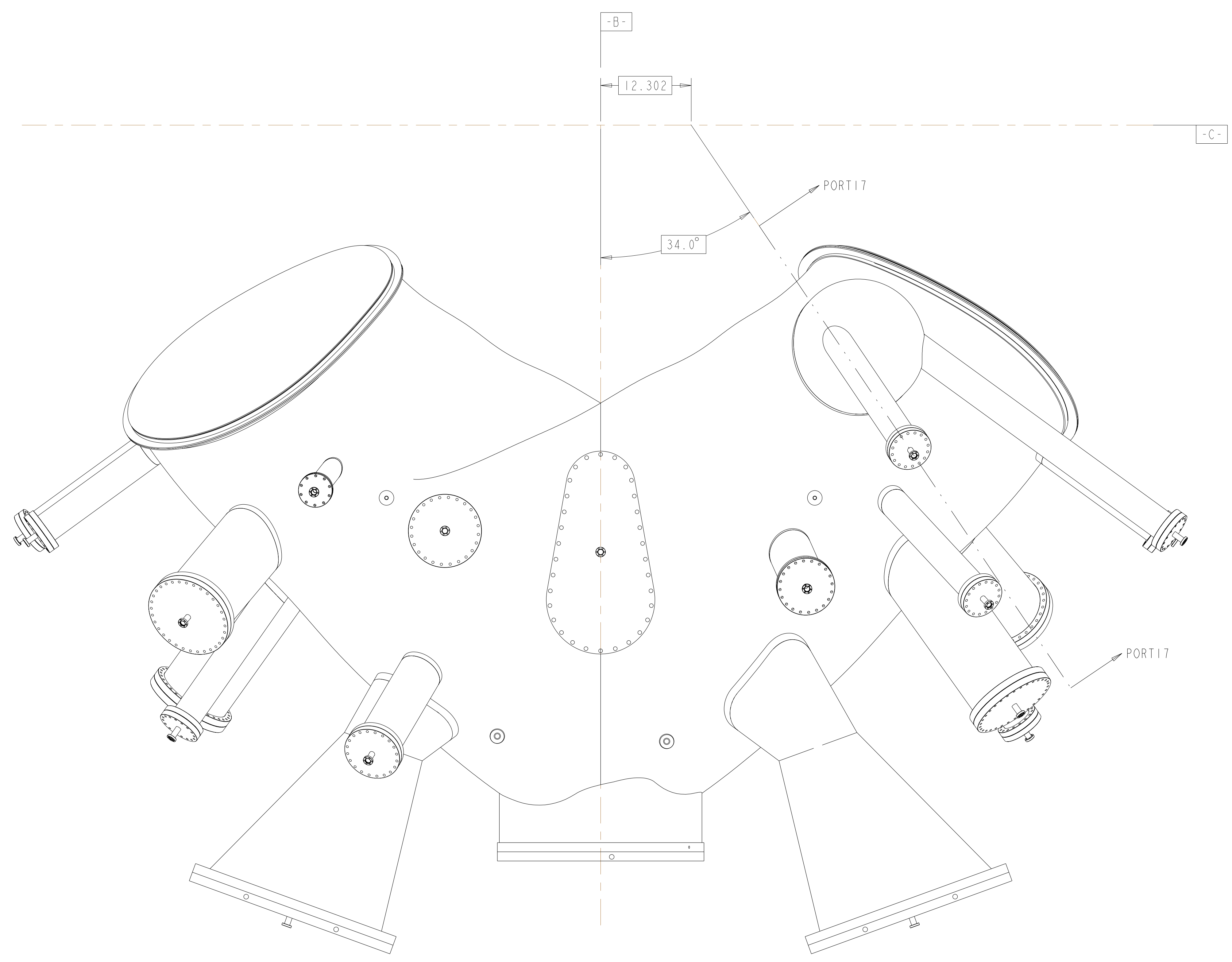

**Rev 2-e: ECN-5021 (RFD-12-017) approved alternate methods for welding the port extensions to the VVSA (See ECN-5021 for details). - Only applicable to VVSA #3 - VVSA #1 and #2 covered by NCR 19464.**

**RELEASED FOR FABRICATION / INSTALLATION**  
 PPPL Drafting:

UT-BATTELLE		Oak Ridge National Laboratory managed for the DEPARTMENT OF ENERGY under U.S. GOVERNMENT contract DE-AC05-00OR22725 UT-BATTELLE, LLC, Oak Ridge, Tennessee					
PROJECT NAME							
NATIONAL COMPACT STELLARATOR EXPERIMENT							
VACUUM VESSEL PERIOD INSPECTION AND LEAK CHECK ASSEMBLY							
VERSION NO.	PLANT	BLDG	FL	SHT OF	TYPE	CLASS	
5	X-10	5700	3	16	19	A	
RELEASE LEVEL		SE120-004			REV		
Fabrication					2		

H  
G  
F  
E  
D  
C  
B  
A



FOR PARTS LIST AND NOTES SEE SHEET 1.

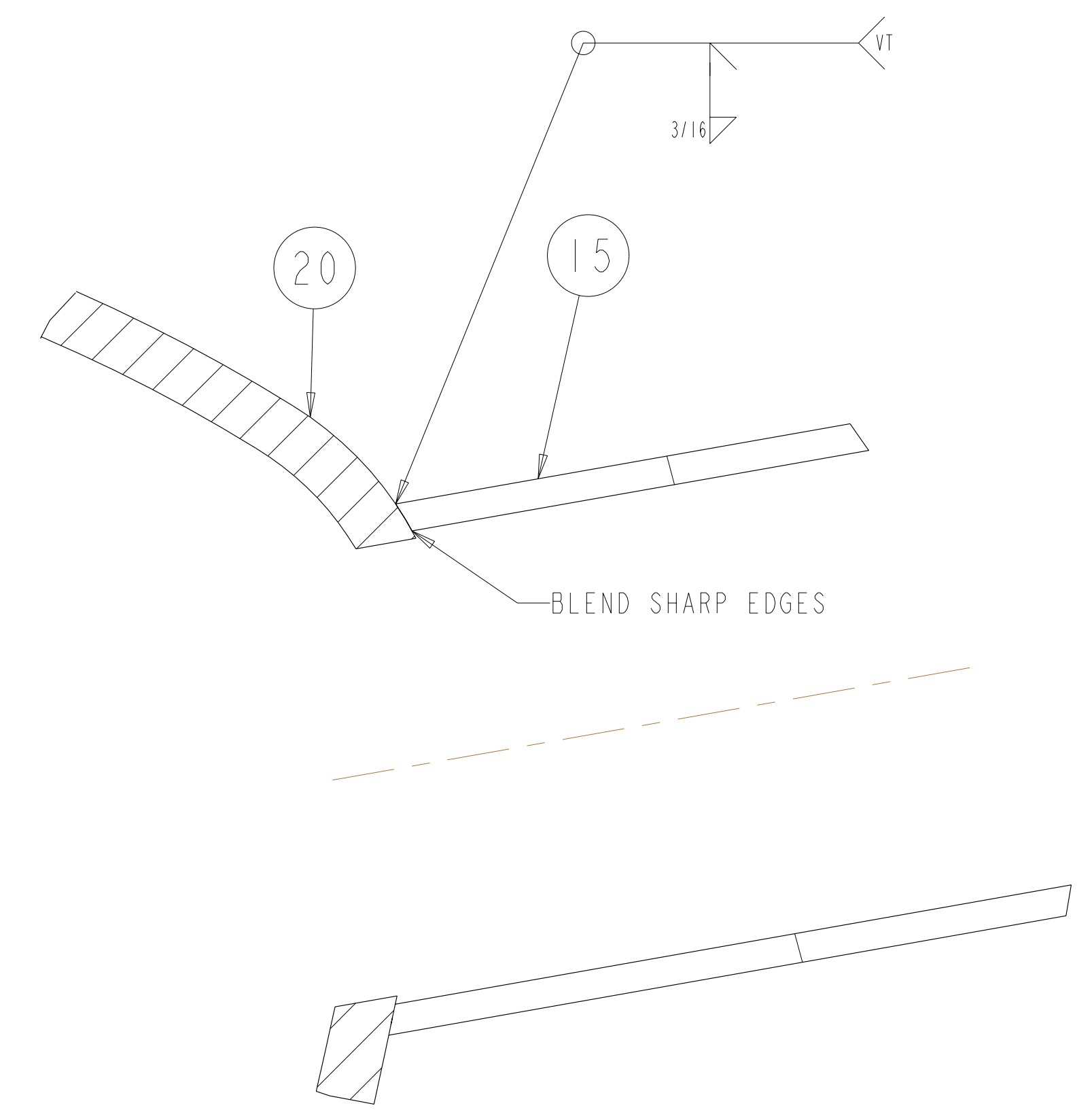
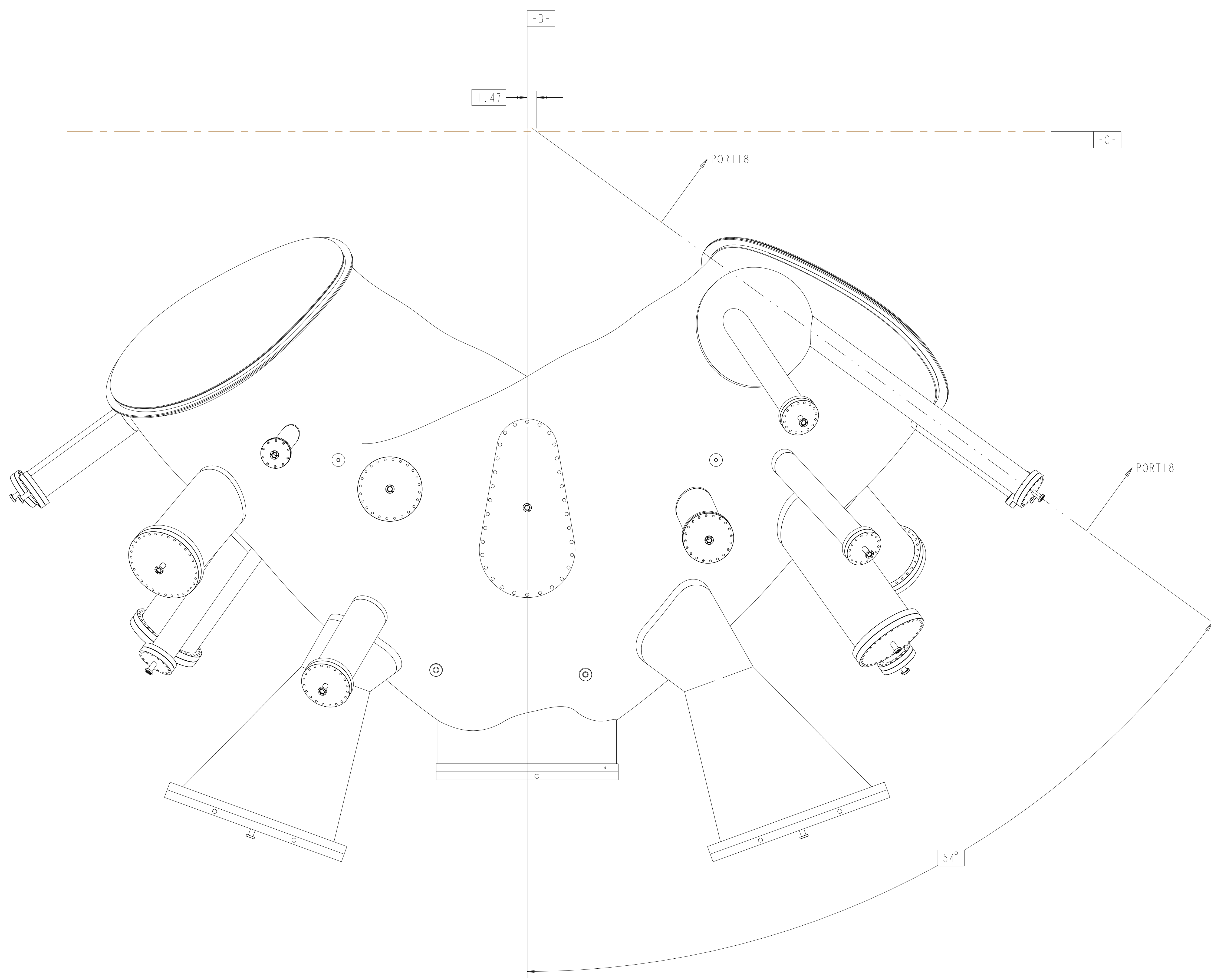

DETAIL X  
SCALE 1.00

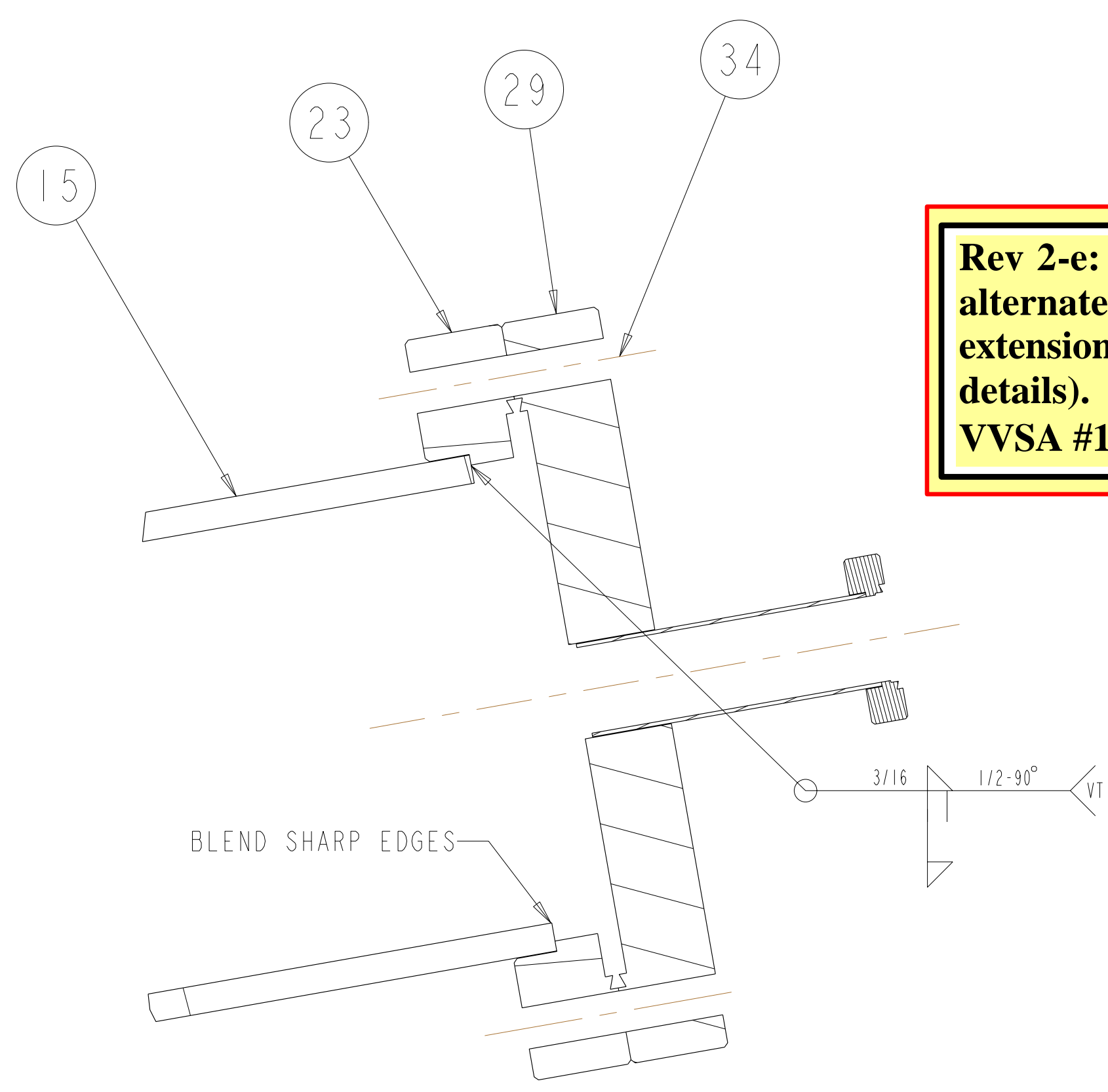

DETAIL Y  
SCALE 1.000

**Rev 2-e: ECN-5021 (RFD-12-017) approved alternate methods for welding the port extensions to the VVSA (See ECN-5021 for details). - Only applicable to VVSA #3 - VVSA #1 and #2 covered by NCR 19464.**

TOP VIEW

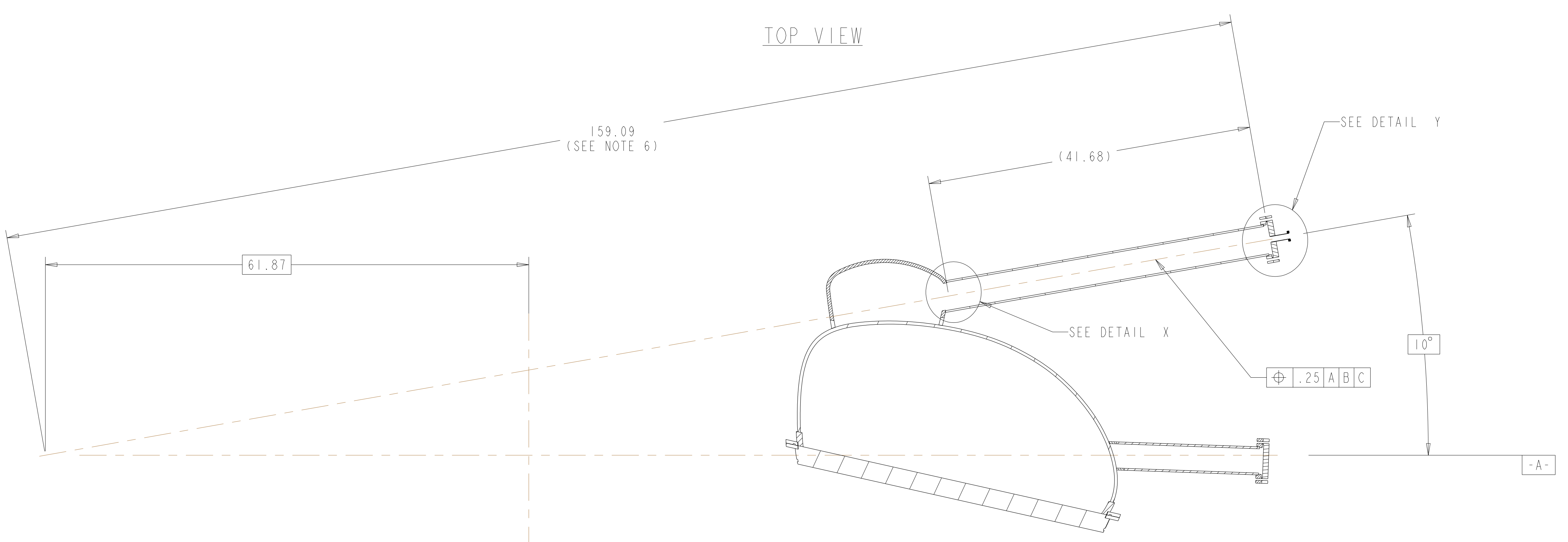

TYPICAL PORT 18A AND 18B  
SECTION PORT18-PORT18

**RELEASED FOR FABRICATION / INSTALLATION**  
 PPPL Drafting:

UT-BATTELLE		Oak Ridge National Laboratory managed for the DEPARTMENT OF ENERGY under U.S. GOVERNMENT contract DE-AC05-00OR22725 UT-BATTELLE, LLC., Oak Ridge, Tennessee	
PROJECT NAME			
NATIONAL COMPACT STELLARATOR EXPERIMENT			
VACUUM VESSEL			
PERIOD INSPECTION AND LEAK CHECK			
ASSEMBLY			
VERSION NO.	PLANT	BLDG	FL
5	X-10	5700	3
RELEASE LEVEL	SHT OF	TYPE	CLASS
Fabrication	17	A	U
SE120-004			REV
			2

H  
G  
F  
E  
D  
C  
B  
A

FOR PARTS LIST AND NOTES SEE SHEET 1.

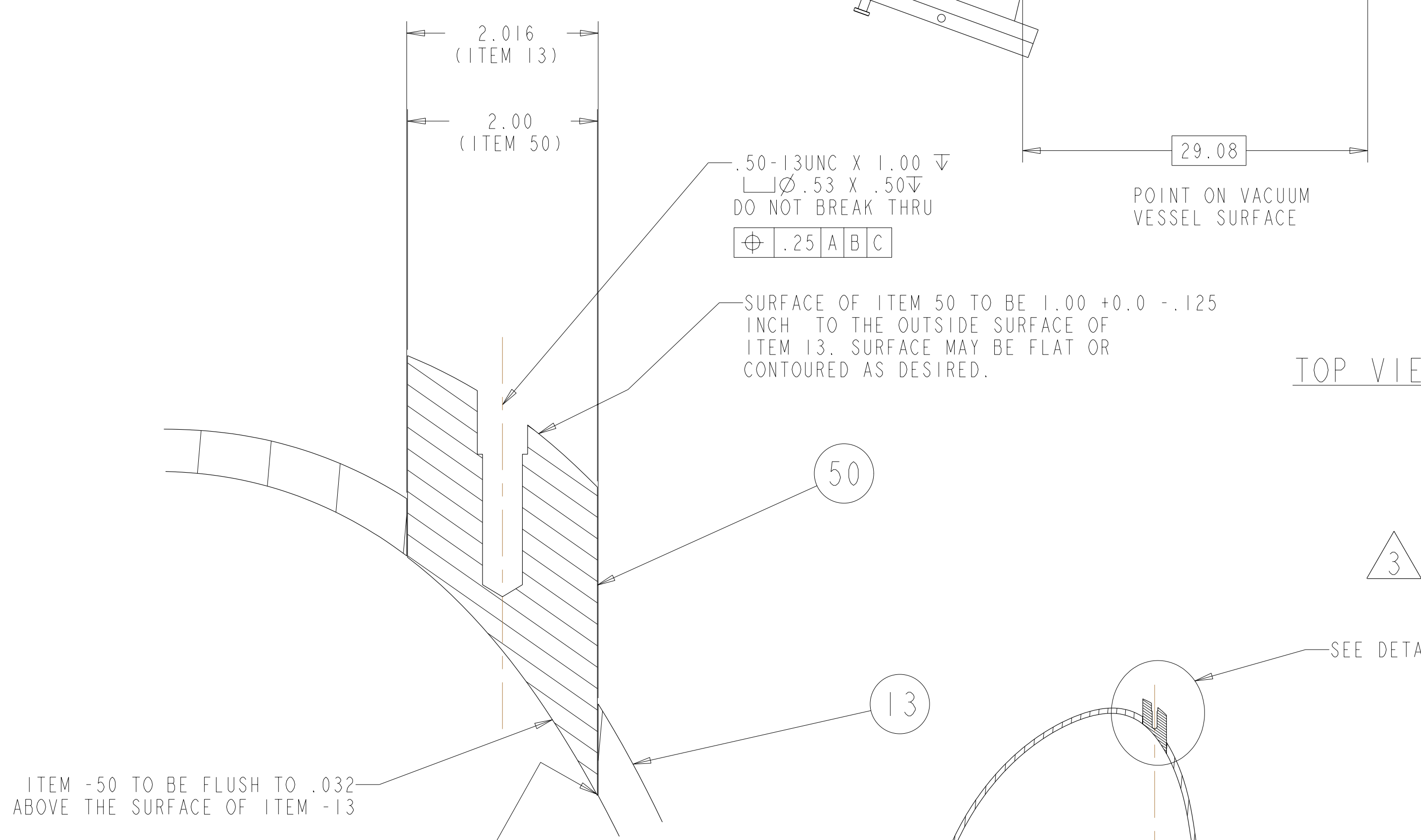
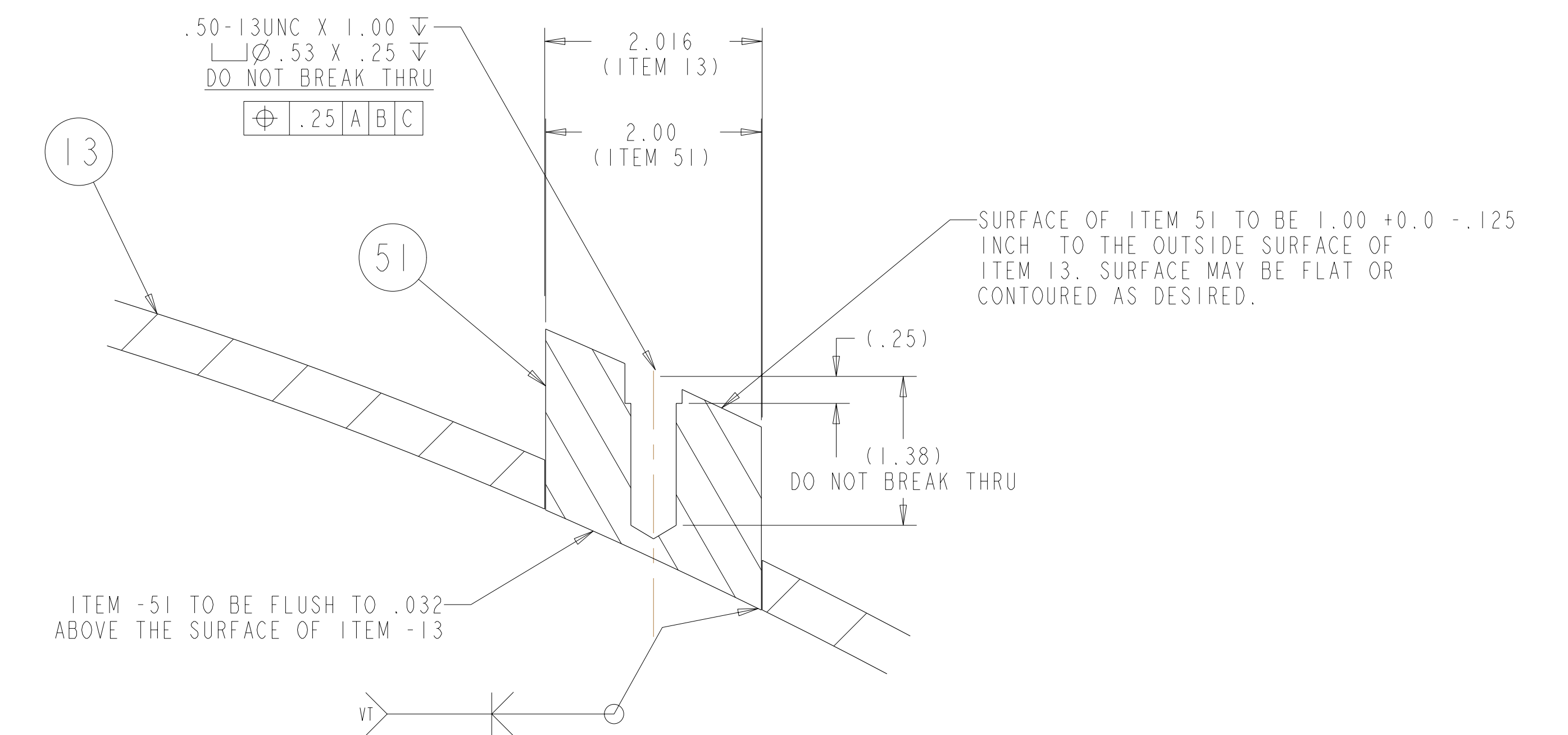
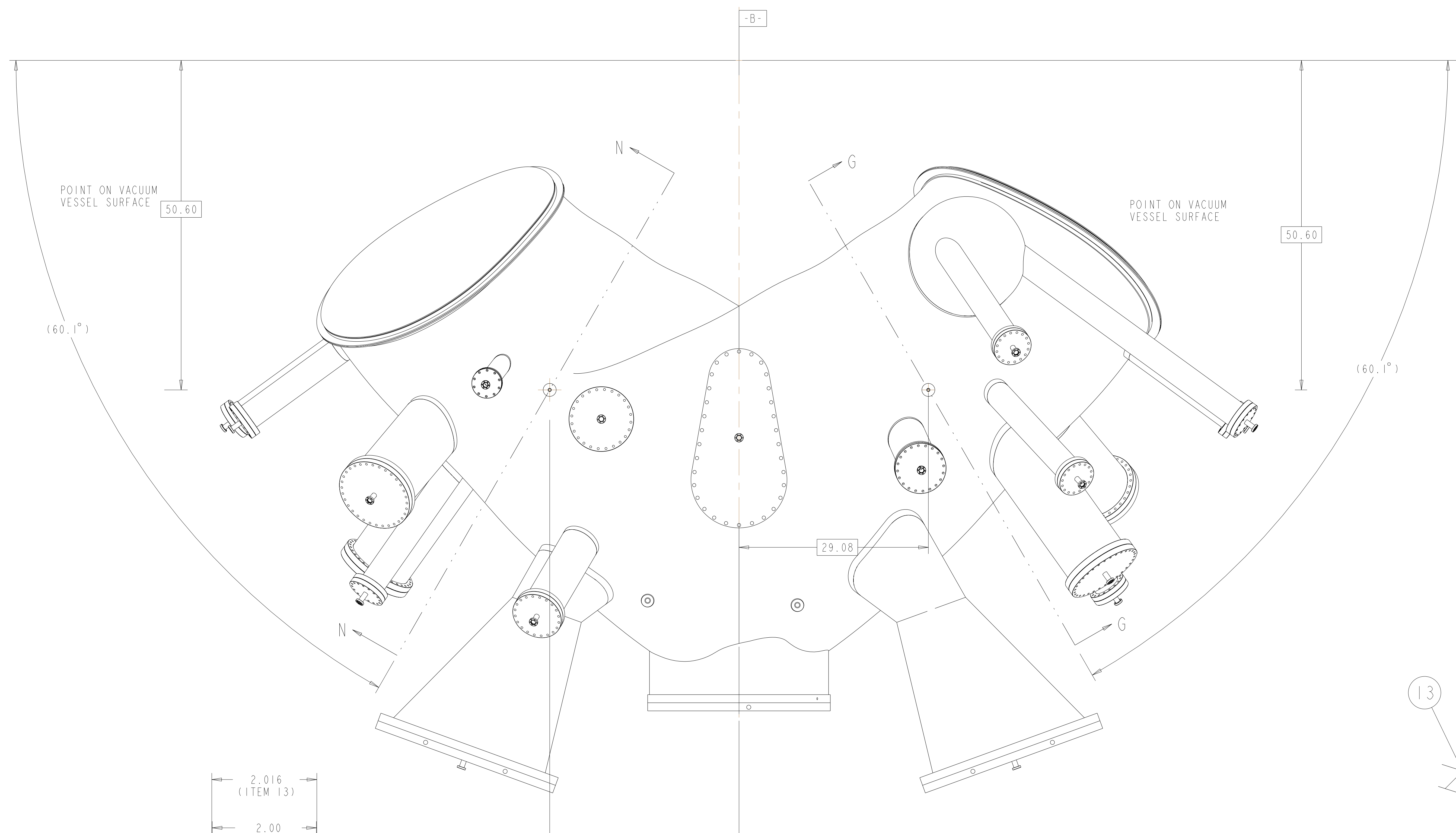

TOP VIEW

DETAIL X  
TYPICAL 2 PLACES  
SCALE 1.00

**Rev 2-e: ECN-5021 (RFD-12-017) approved alternate methods for welding the port extensions to the VVSA (See ECN-5021 for details). - Only applicable to VVSA #3 - VVSA #1 and #2 covered by NCR 19464.**

**RELEASED FOR FABRICATION / INSTALLATION**  
PPPL Drafting:

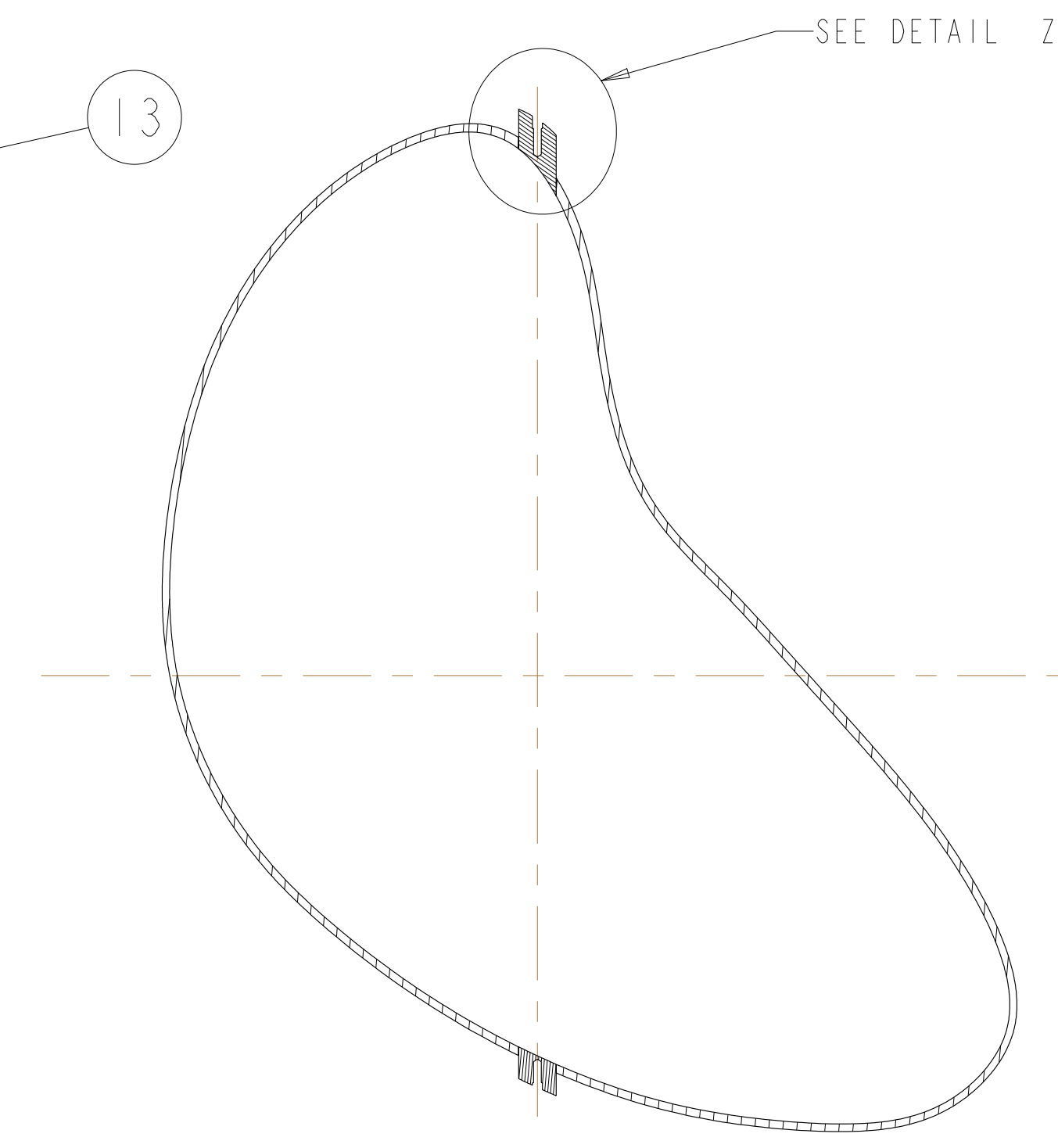

SECTION N-N

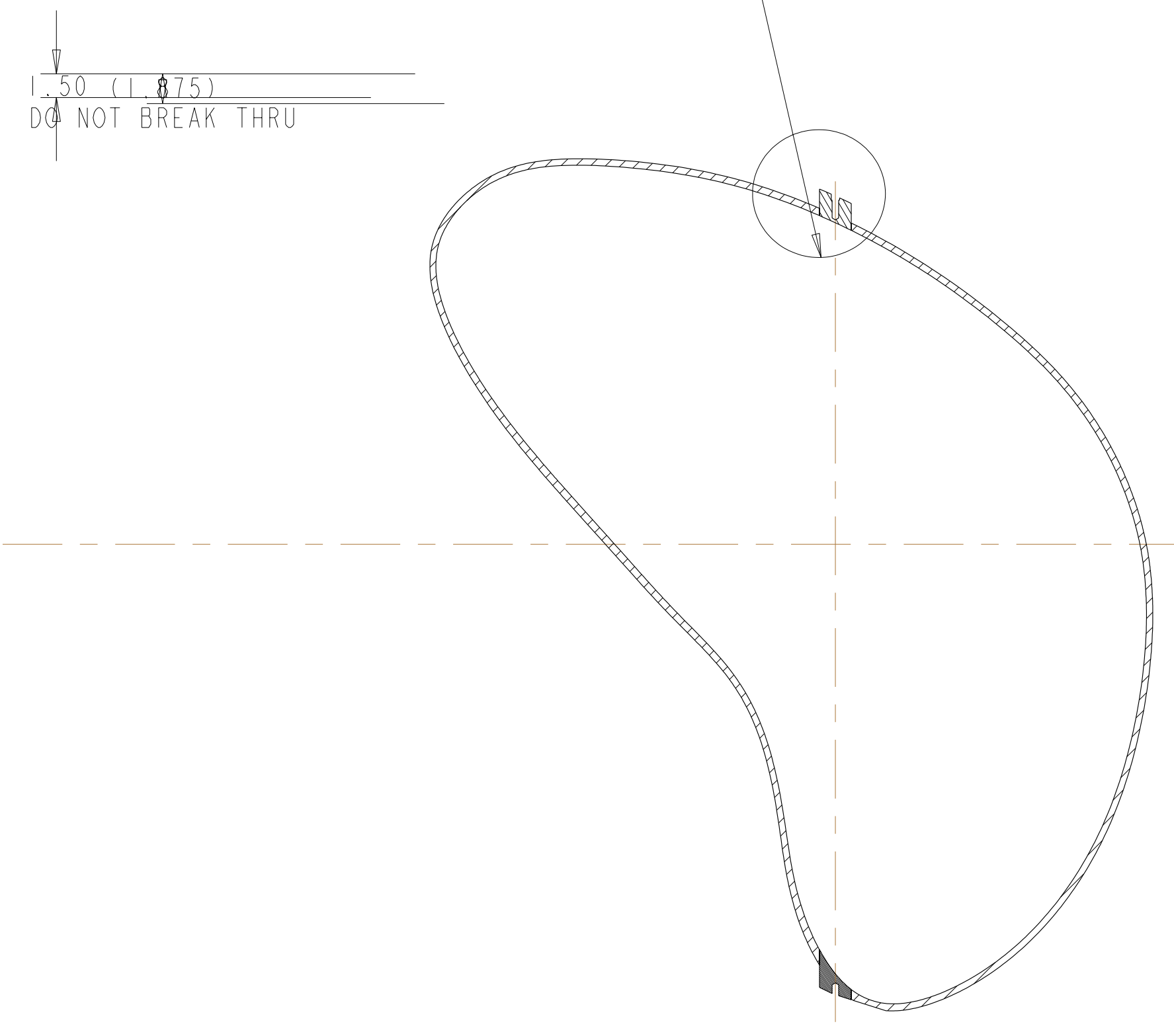

SECTION G-G

UT-BATTELLE		Oak Ridge National Laboratory managed for the DEPARTMENT OF ENERGY under U.S. GOVERNMENT contract DE-AC05-00OR22725 UT-BATTELLE, LLC, Oak Ridge, Tennessee					
PROJECT NAME							
NATIONAL COMPACT STELLARATOR EXPERIMENT							
VACUUM VESSEL							
PERIOD INSPECTION AND LEAK CHECK							
ASSEMBLY							
VERSION NO.	PLANT	BLDG	FL	SHT OF	TYPE	CLASS	
3+	X-10	5700	3	8	19 A	U	
RELEASE LEVEL		SE120-004				REV	
Fabrication						2	

FOR PARTS LIST AND NOTES SEE SHEET 1.

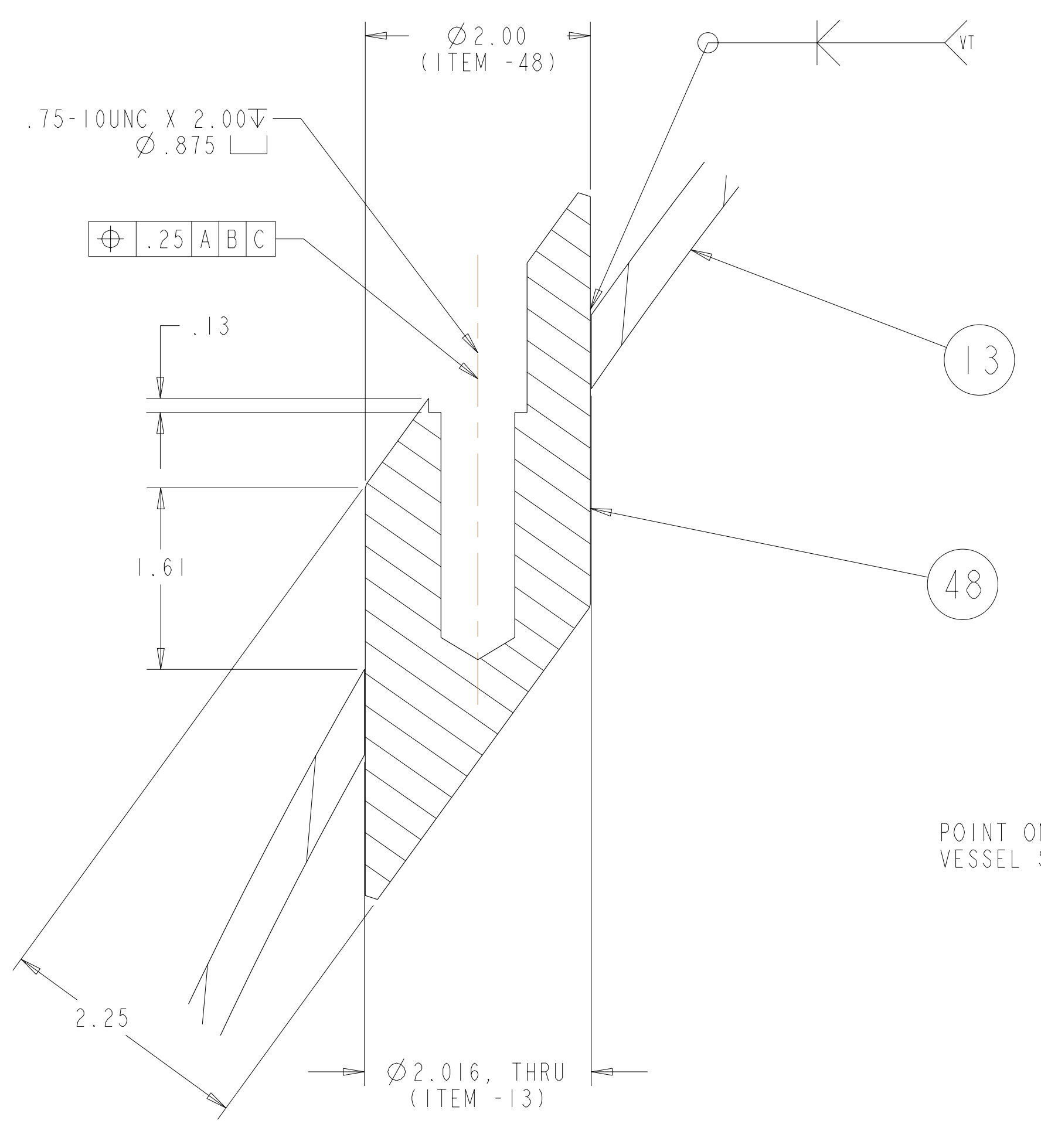

DETAIL W  
 SCALE 1.00

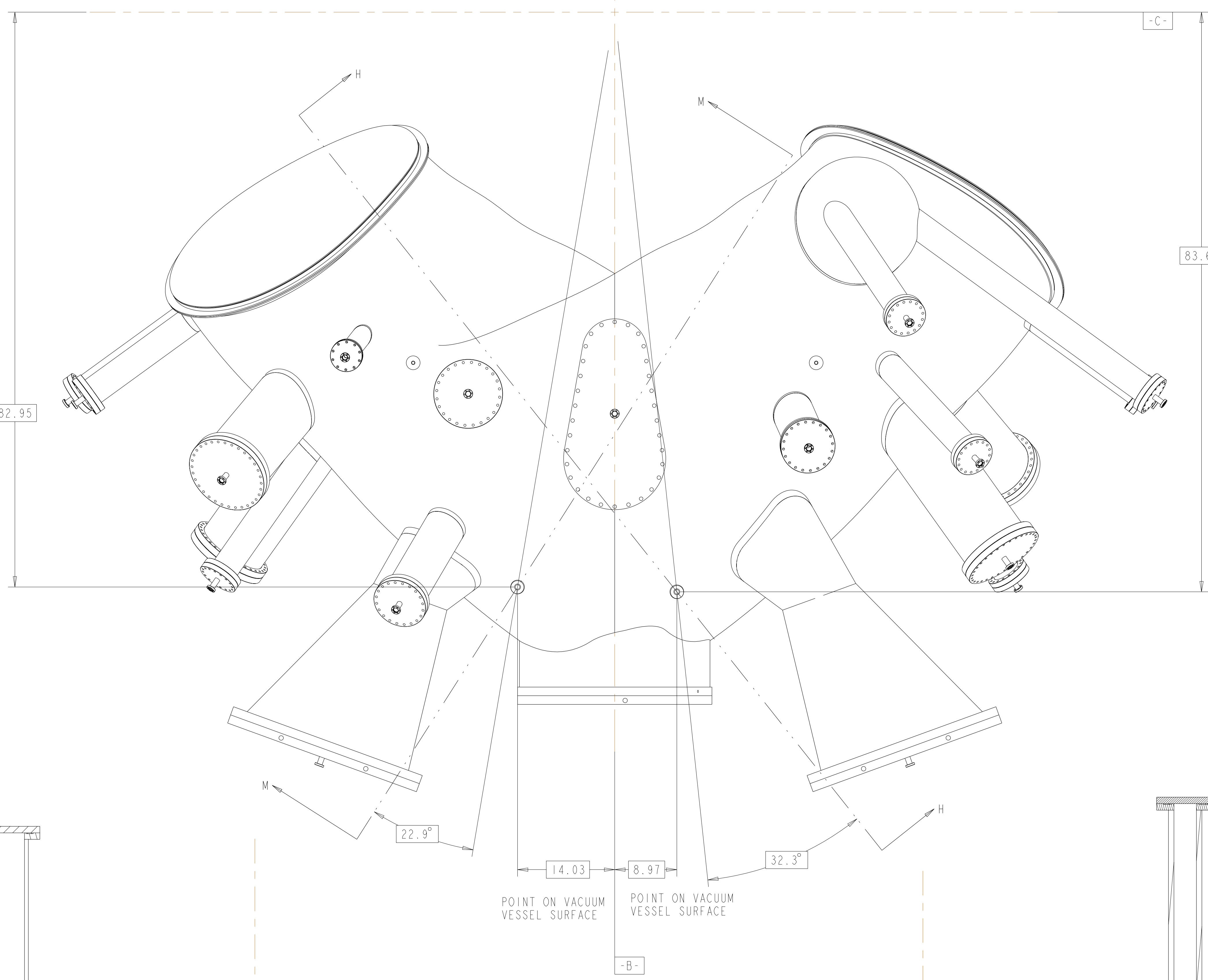

TOP VIEW

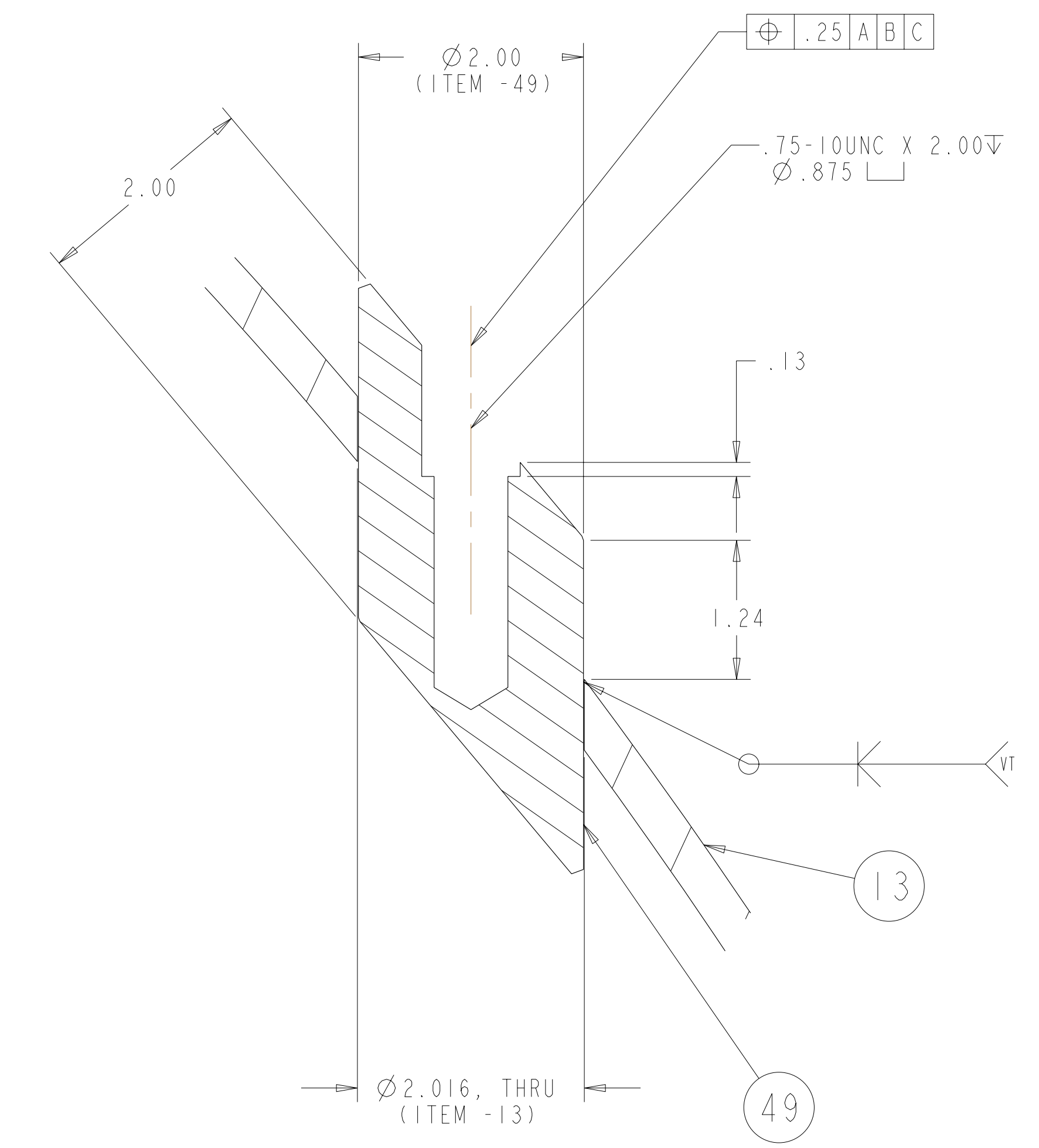

DETAIL Y  
 SCALE 1.00

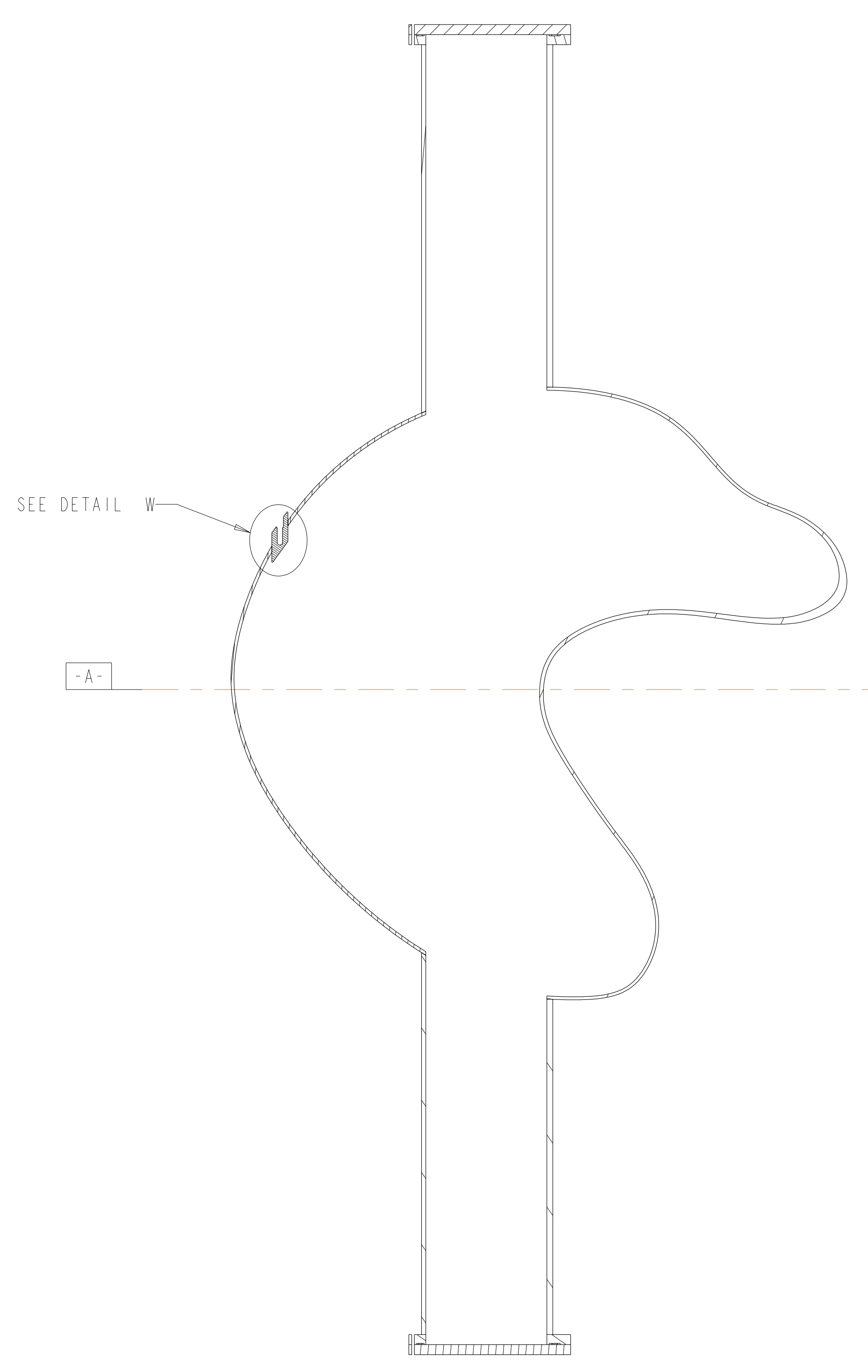

SECTION M-M  
 SCALE 0.09

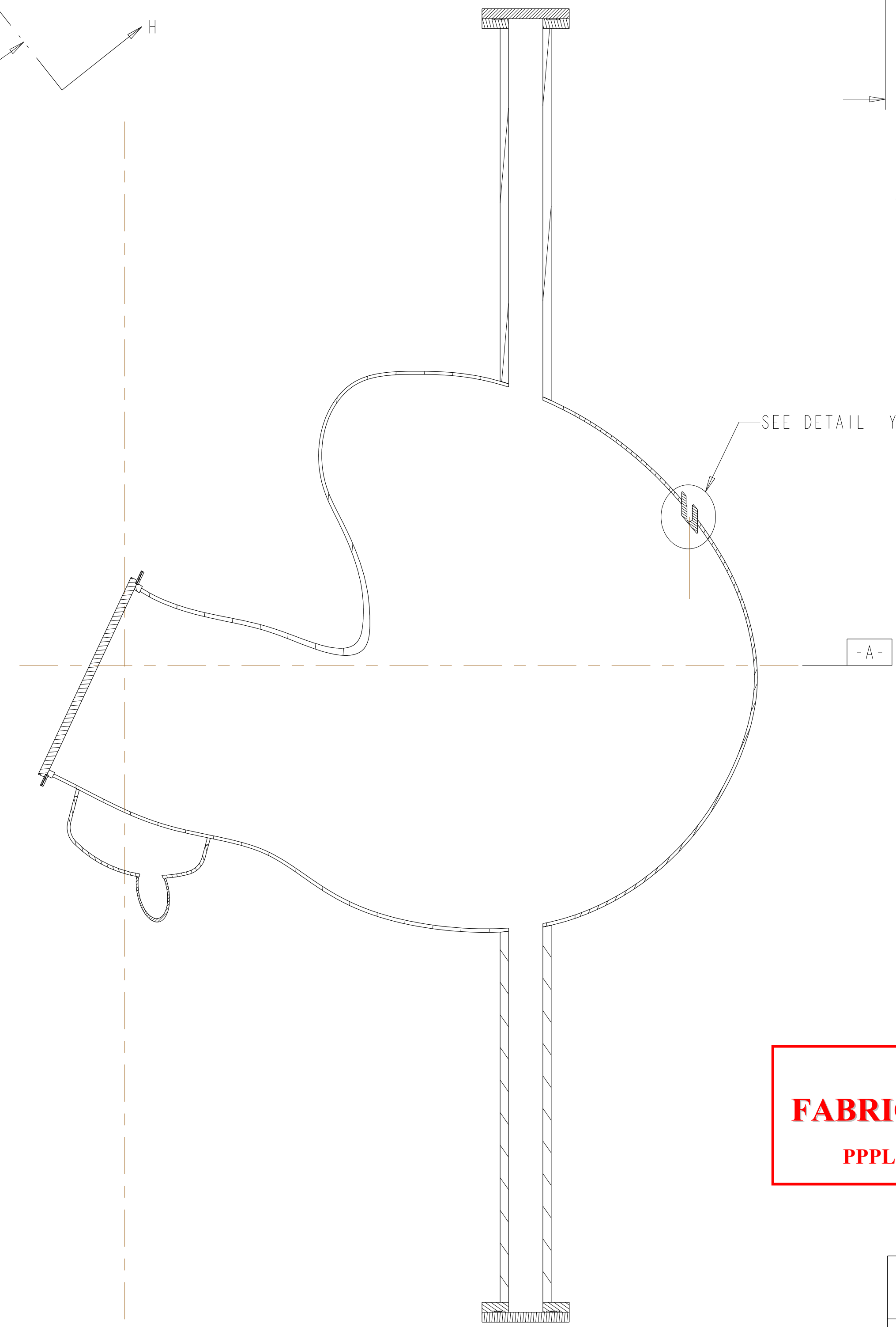

SECTION H-H  
 SCALE 0.09

**Rev 2-e: ECN-5021 (RFD-12-017) approved alternate methods for welding the port extensions to the VVSA (See ECN-5021 for details). - Only applicable to VVSA #3 - VVSA #1 and #2 covered by NCR 19464.**

**RELEASED FOR FABRICATION / INSTALLATION**  
 PPPL Drafting:

Oak Ridge National Laboratory managed for the DEPARTMENT OF ENERGY under U.S. GOVERNMENT CONTRACT DE-AC05-00OR22725 UT-BATTELLE, LLC. Oak Ridge, Tennessee PROJECT NAME							
NATIONAL COMPACT STELLARATOR EXPERIMENT VACUUM VESSEL PERIOD INSPECTION AND LEAK CHECK ASSEMBLY							
VERSION NO.	PLANT	BLDG	FL	SHT OF	TYPE	CLASS	
5	X-10	5700	3	19 19	A	U	
RELEASE LEVEL		SEI20-004		REV			
Fabrication				2			

H  
G  
F  
E  
D  
C  
B  
A