

SECTION B-B
 SCALE 0.50

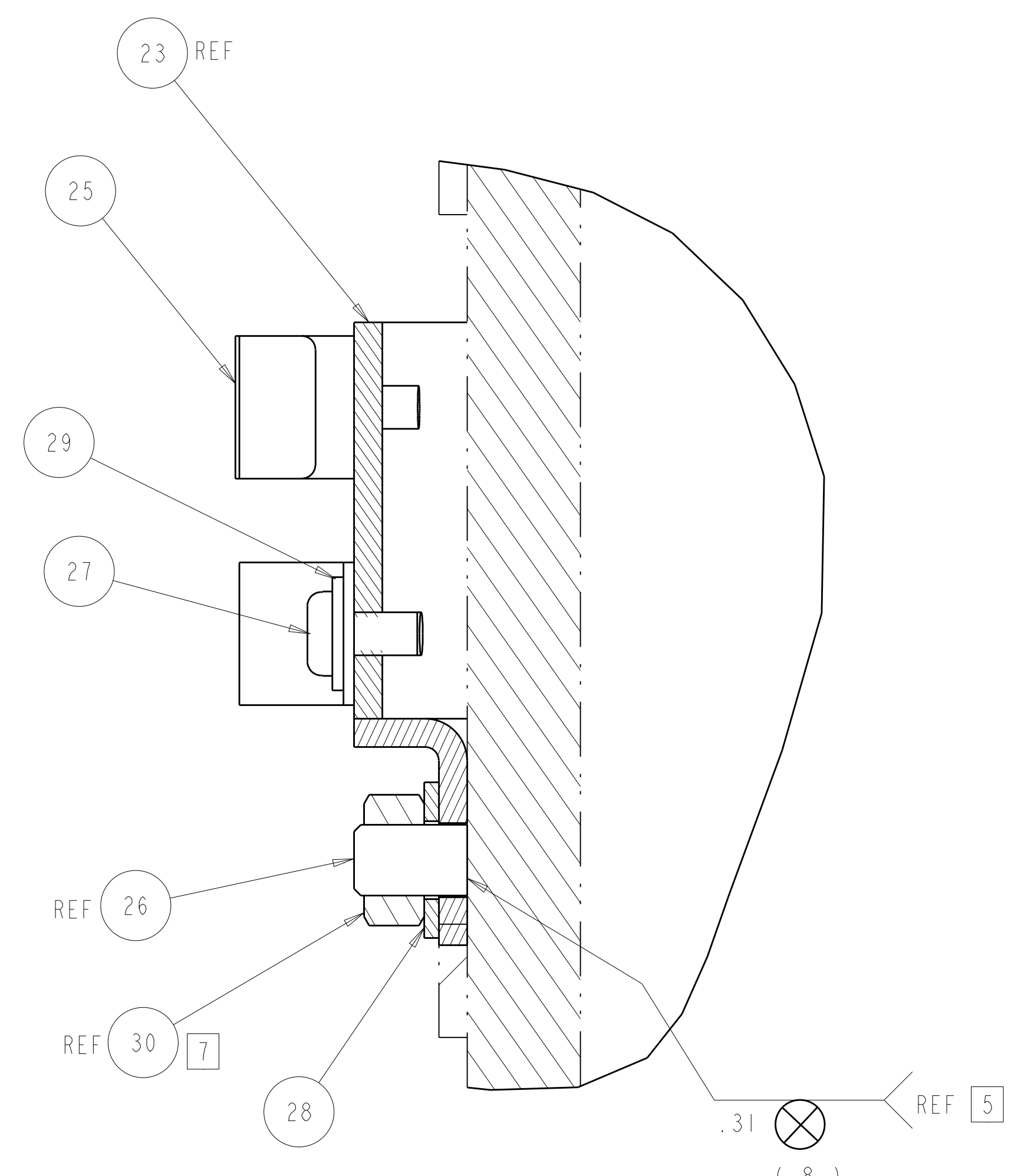

SECTION E-E
 SCALE 2.00

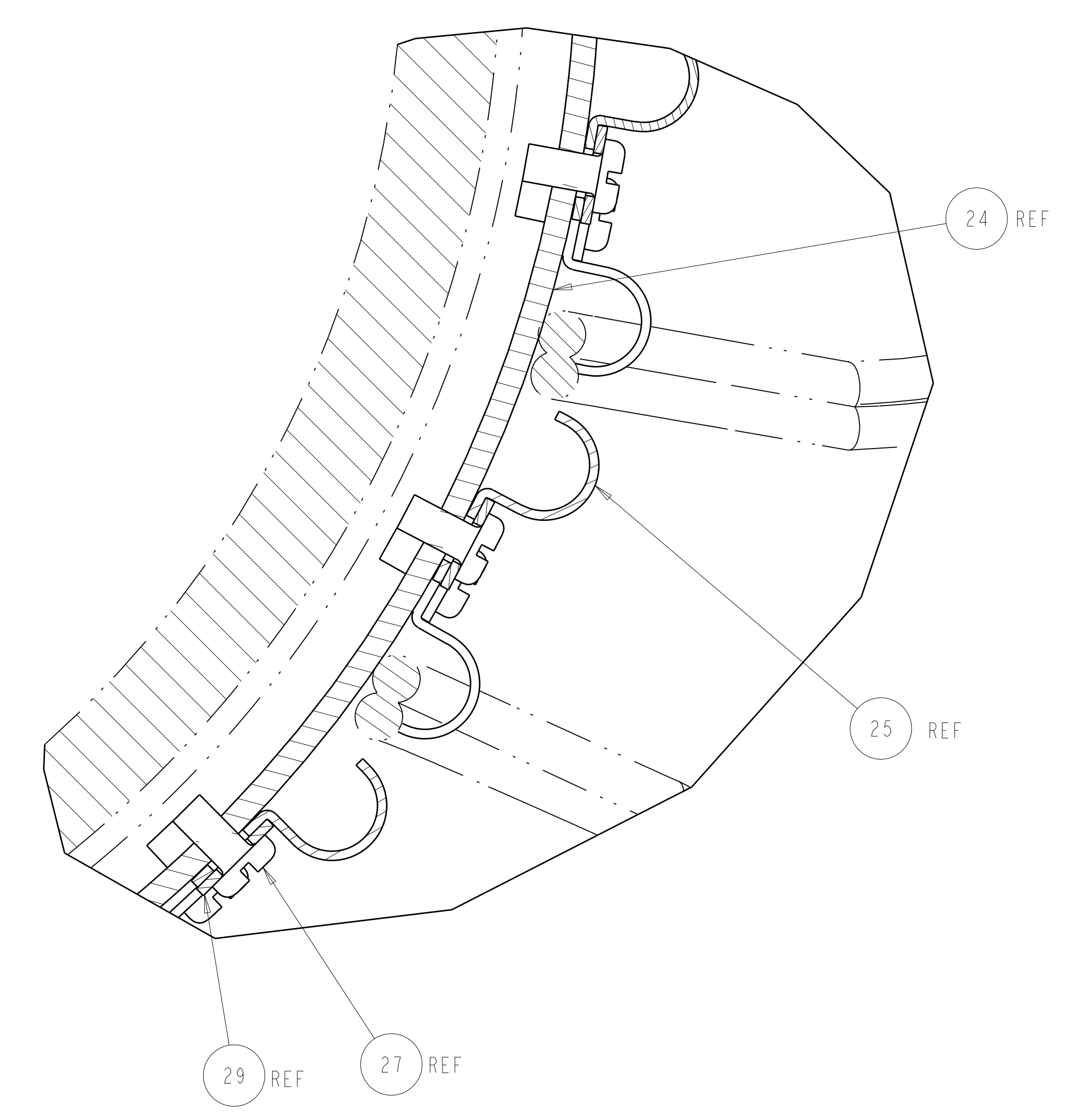

DETAIL B
 SCALE 2.00

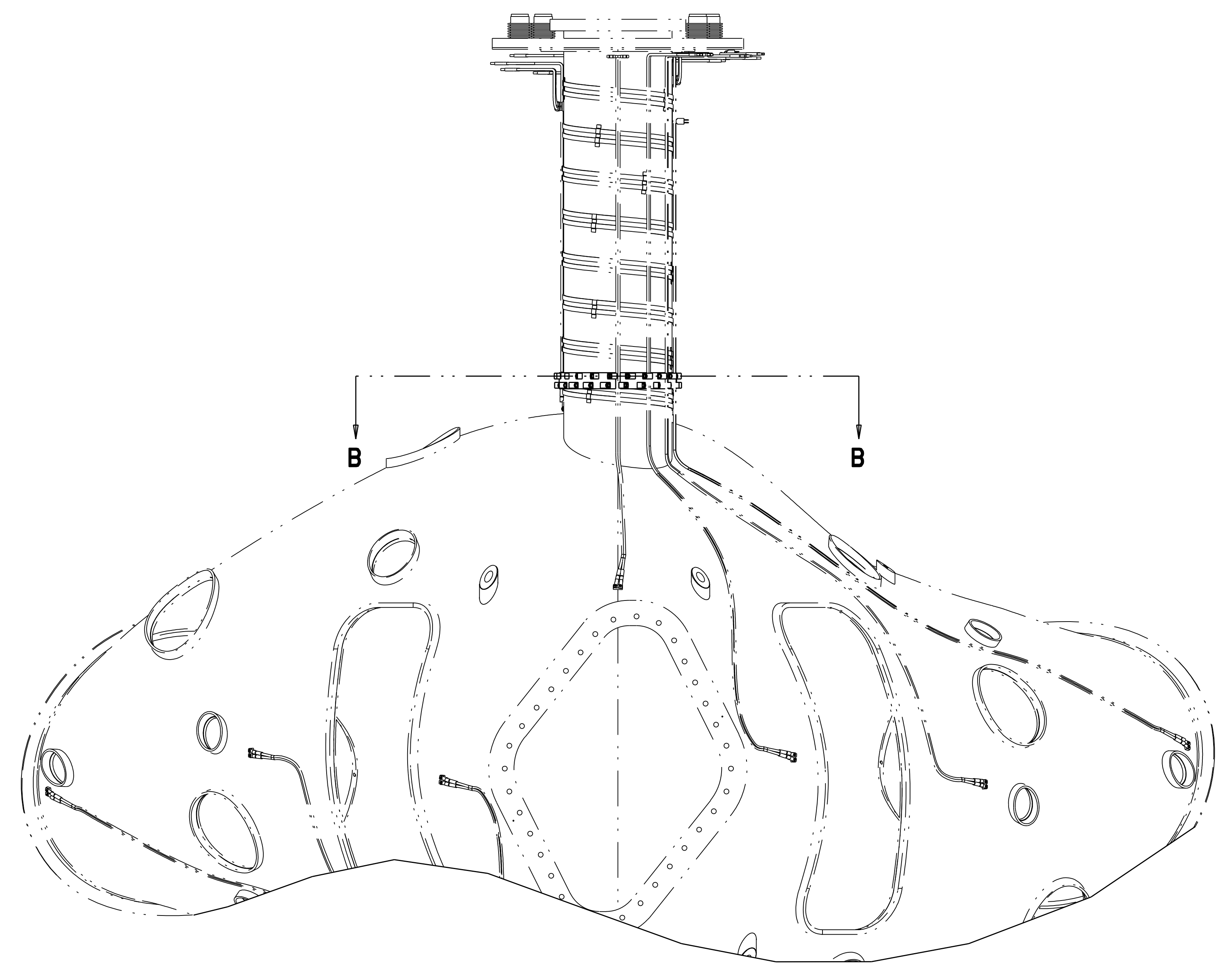

SCALE 0.13

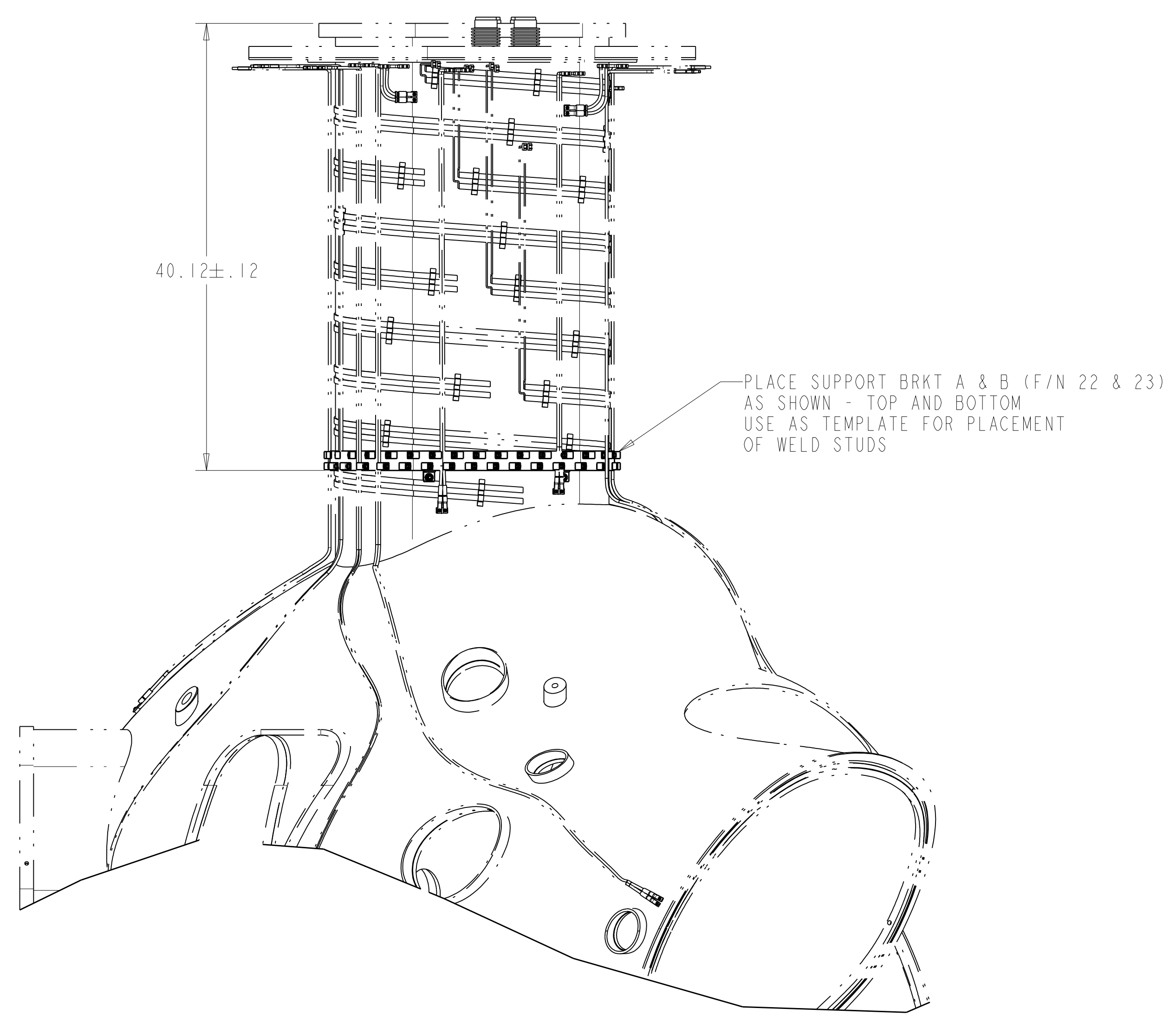

**RELEASED FOR
 FABRICATION / INSTALLATION**
 PPPL Drafting:

UT-BATTELLE		Oak Ridge National Laboratory managed for the DEPARTMENT OF ENERGY under U.S. GOVERNMENT contract DE-AC05-00OR22725 UT-BATTELLE, LLC, Oak Ridge, Tennessee	
NATIONAL COMPACT STELLARATOR EXPERIMENT			
VVSA ASSEMBLY STATION 1, PHASE 2			
VERSION NO. 1	PLANT ORNL	BLDG 5700	FL SHT OF TYPE CLASS 3 2 5 A U
RELEASE LEVEL Fabrication		SEI21-008	

H
G
F
E
D
C
B
A

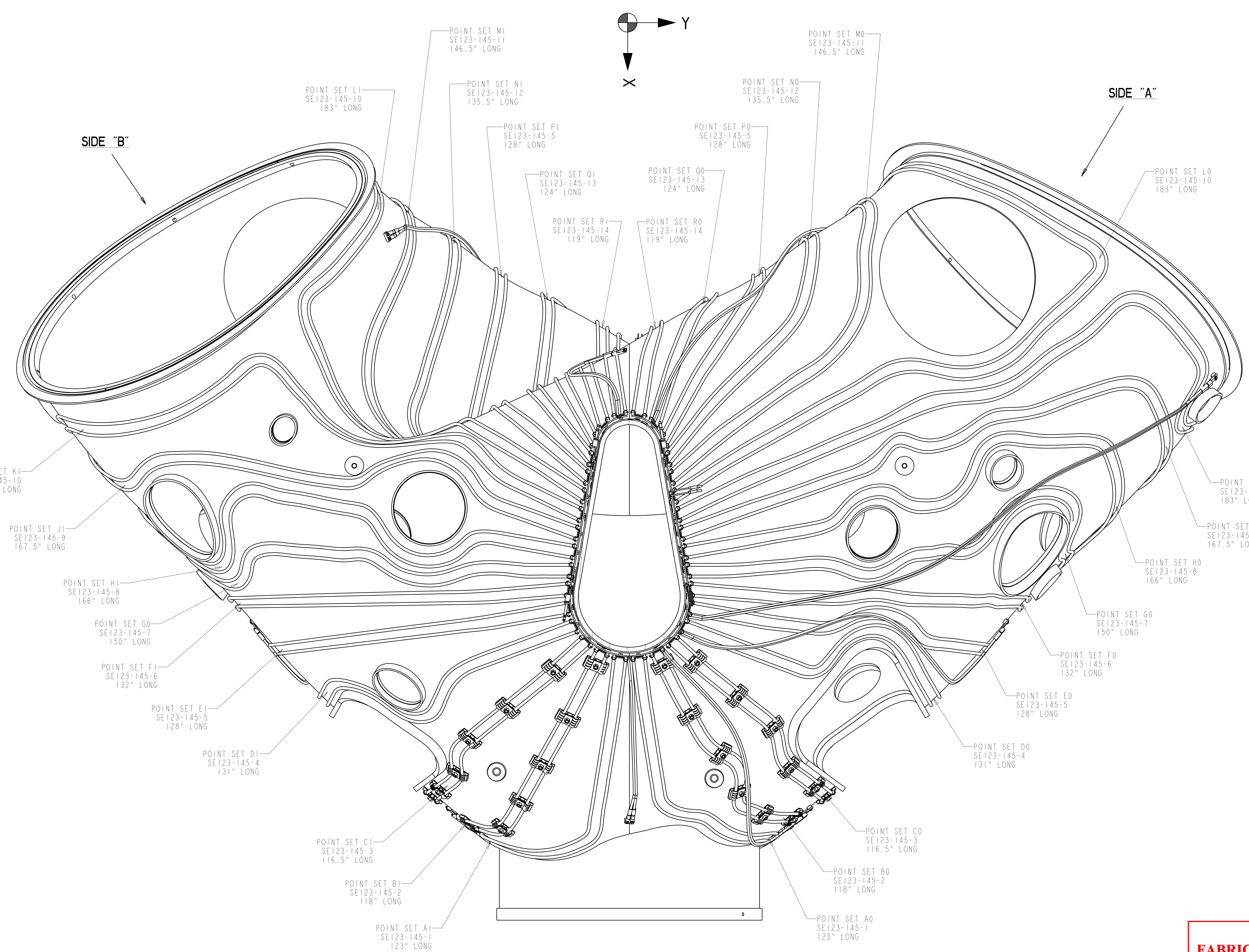

SCALE .25

HEATING / COOLING TUBE PATHS ARE DEFINED BY POINT CHART ON NEXT SHEETS

RELEASED FOR FABRICATION / INSTALLATION
 PPPL Drafting:

Oak Ridge National Laboratory managed for the DEPARTMENT OF ENERGY under U.S. GOVERNMENT contract DE-AC05-00OR22725 UT-BATTELLE, LLC. Oak Ridge, Tennessee						
UT-BATTELLE						
NATIONAL COMPACT STELLARATOR EXPERIMENT						
VVSA ASSEMBLY STATION 1, PHASE 2						
VERSION NO.	PLANT	BLDG	FL	SHT OF	TYPE	CLASS
1	ORNL	5700	3	3 5	A	U
RELEASE LEVEL		REV				
Fabrication		SE121-008 1				

H G F E D C B A

H G F E D C B A

SIDE B POINT SET AI

Table with 4 columns: PT #, X, Y, Z. Rows A001 to A018.

SIDE A POINT SET AO

Table with 4 columns: PT #, X, Y, Z. Rows A001 to A018.

SIDE B POINT SET EI

Table with 4 columns: PT #, X, Y, Z. Rows E001 to E019.

SIDE A POINT SET EO

Table with 4 columns: PT #, X, Y, Z. Rows E001 to E019.

SIDE B POINT SET HI

Table with 4 columns: PT #, X, Y, Z. Rows H001 to H028.

SIDE A POINT SET HO

Table with 4 columns: PT #, X, Y, Z. Rows H001 to H028.

SIDE B POINT SET BI

Table with 4 columns: PT #, X, Y, Z. Rows B001 to B017.

SIDE A POINT SET BO

Table with 4 columns: PT #, X, Y, Z. Rows B001 to B017.

SIDE B POINT SET FI

Table with 4 columns: PT #, X, Y, Z. Rows F001 to F021.

SIDE A POINT SET FO

Table with 4 columns: PT #, X, Y, Z. Rows F001 to F021.

SIDE B POINT SET JI

Table with 4 columns: PT #, X, Y, Z. Rows J001 to J029.

SIDE A POINT SET JO

Table with 4 columns: PT #, X, Y, Z. Rows J001 to J029.

SIDE B POINT SET CI

Table with 4 columns: PT #, X, Y, Z. Rows C001 to C016.

SIDE A POINT SET CO

Table with 4 columns: PT #, X, Y, Z. Rows C001 to C016.

SIDE B POINT SET GI

Table with 4 columns: PT #, X, Y, Z. Rows G001 to G024.

SIDE A POINT SET GO

Table with 4 columns: PT #, X, Y, Z. Rows G001 to G024.

SIDE B POINT SET DI

Table with 4 columns: PT #, X, Y, Z. Rows D001 to D020.

SIDE A POINT SET DO

Table with 4 columns: PT #, X, Y, Z. Rows D001 to D020.

RELEASED FOR FABRICATION / INSTALLATION PPPL Drafting:

UT-BATTELLE Oak Ridge National Laboratory... NATIONAL COMPACT STELLARATOR EXPERIMENT VVSA ASSEMBLY STATION 1, PHASE 2

H G F E D C A

H G F E D C A

SIDE B POINT SET KI

Table with 4 columns: PT #, X, Y, Z. Rows K001 to K033.

SIDE A POINT SET KO

Table with 4 columns: PT #, X, Y, Z. Rows K001 to K033.

SIDE B POINT SET MI

Table with 4 columns: PT #, X, Y, Z. Rows M001 to M024.

SIDE A POINT SET MO

Table with 4 columns: PT #, X, Y, Z. Rows M001 to M024.

SIDE B POINT SET QI

Table with 4 columns: PT #, X, Y, Z. Rows Q001 to Q020.

SIDE A POINT SET QO

Table with 4 columns: PT #, X, Y, Z. Rows Q001 to Q020.

SIDE B POINT SET LI

Table with 4 columns: PT #, X, Y, Z. Rows L001 to L034.

SIDE A POINT SET LO

Table with 4 columns: PT #, X, Y, Z. Rows L001 to L034.

SIDE B POINT SET NI

Table with 4 columns: PT #, X, Y, Z. Rows N001 to N022.

SIDE A POINT SET NO

Table with 4 columns: PT #, X, Y, Z. Rows N001 to N022.

SIDE B POINT SET RI

Table with 4 columns: PT #, X, Y, Z. Rows R001 to R019.

SIDE A POINT SET RO

Table with 4 columns: PT #, X, Y, Z. Rows R001 to R019.

SIDE B POINT SET PI

Table with 4 columns: PT #, X, Y, Z. Rows P001 to P021.

SIDE A POINT SET PO

Table with 4 columns: PT #, X, Y, Z. Rows P001 to P021.

RELEASED FOR FABRICATION / INSTALLATION PPPL Drafting:

UT-BATTELLE logo, NATIONAL COMPACT STELLARATOR EXPERIMENT, VVSA ASSEMBLY STATION 1, PHASE 2, PROJECT NAME, VERSION NO., PLANT ORNL, BLDG 5700, FL 3, SHT OF 5, TYPE A, CLASS U, RELEASE LEVEL Fabrication, SEI21-008, REV I

SEI21-008

A