

- NOTES
1. DRAWING PREPARED IN ACCORDANCE WITH ASME Y14.100-2004.
 2. INTERPRET DIMENSIONS AND TOLERANCES PER ASME Y14.5M-1994.
 3. DIMENSIONS ARE IN INCHES.
 4. PART TO BE MANUFACTURED FROM PRO/ENGINEER DATA FILE SE122-353.PRT DIMENSIONS SHOWN ARE FOR PART VERIFICATION ONLY.

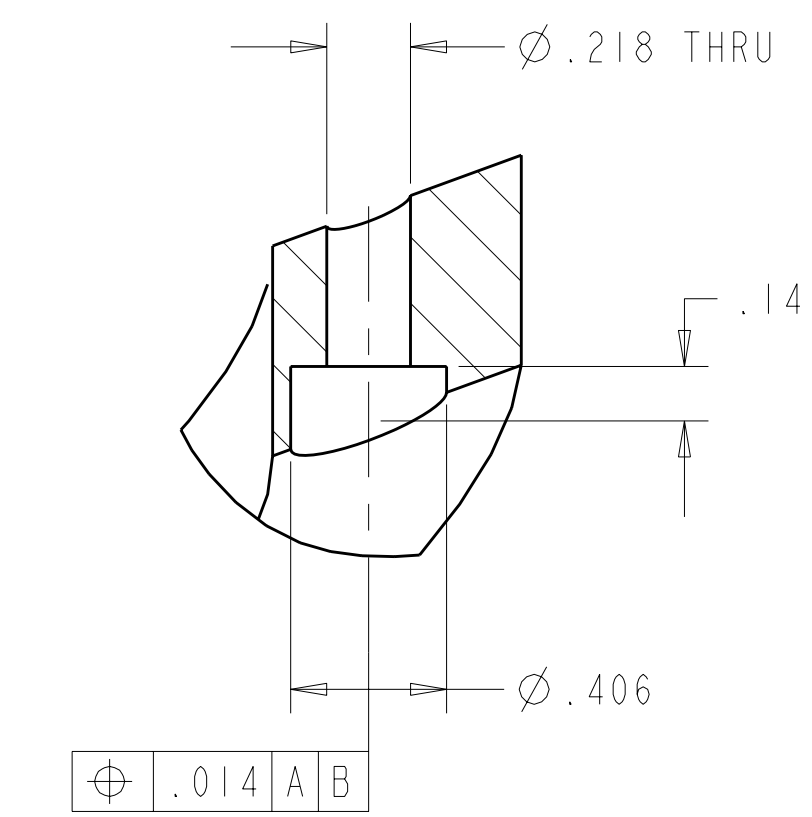

SECTION A-A
TYP 8X
SCALE 2.000

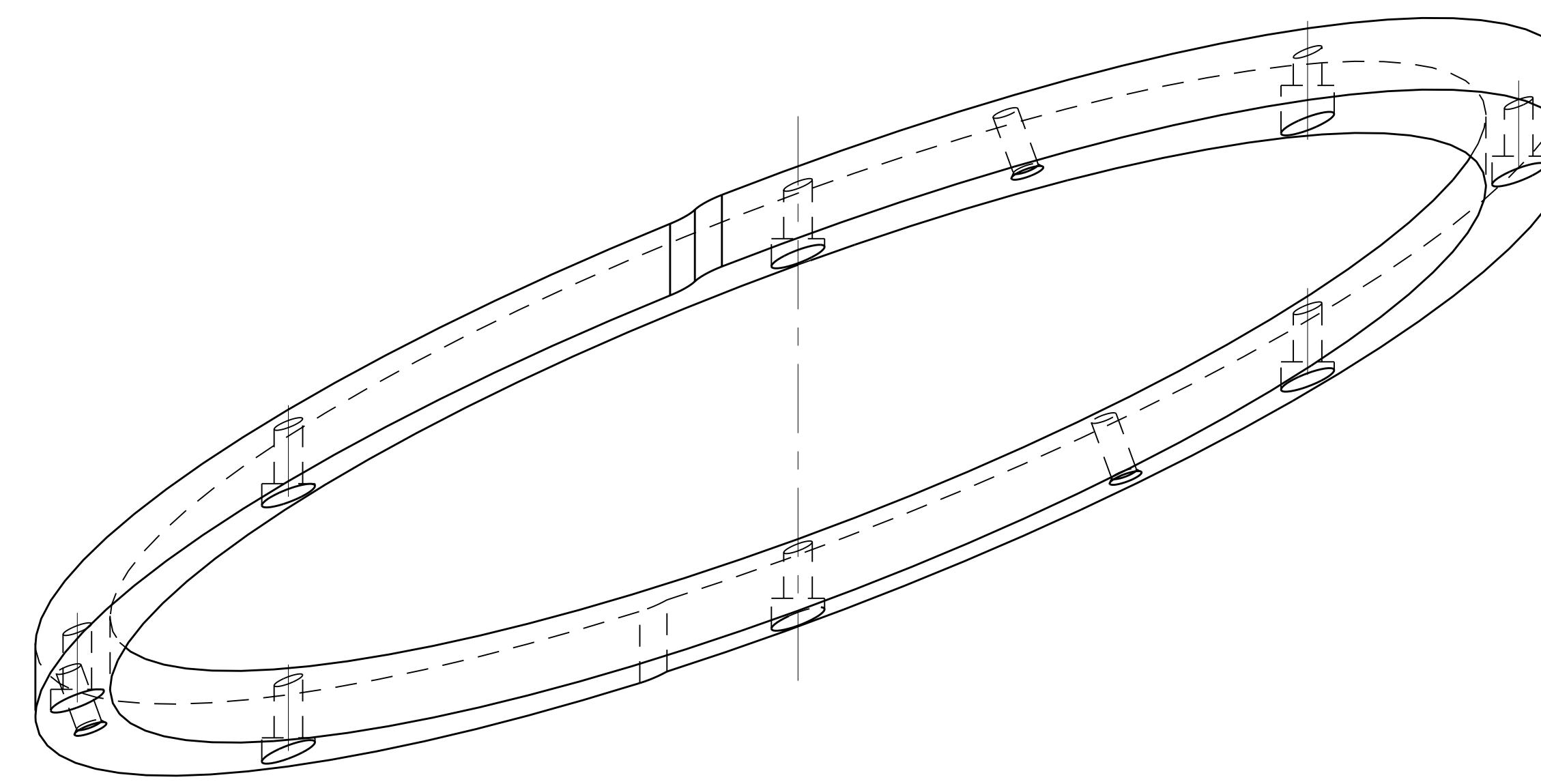
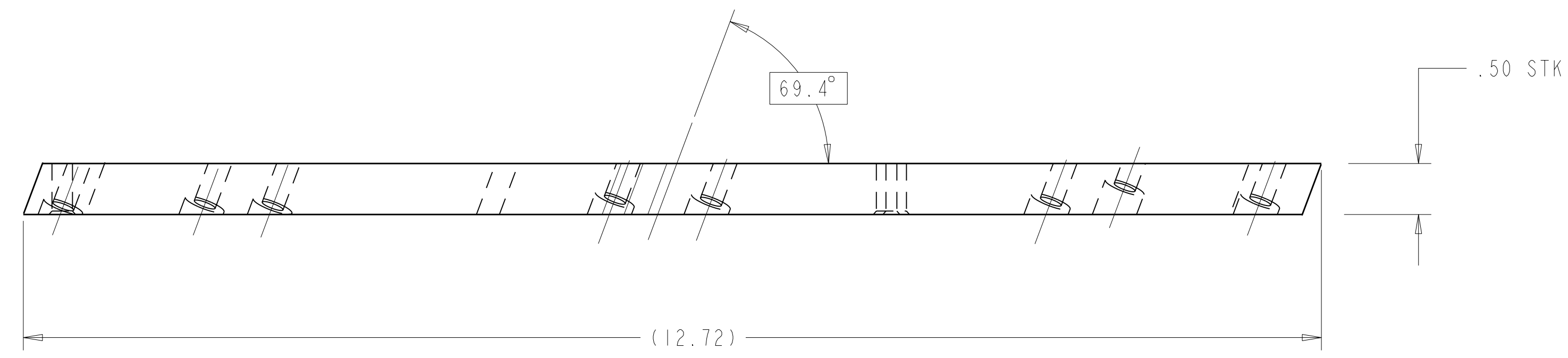
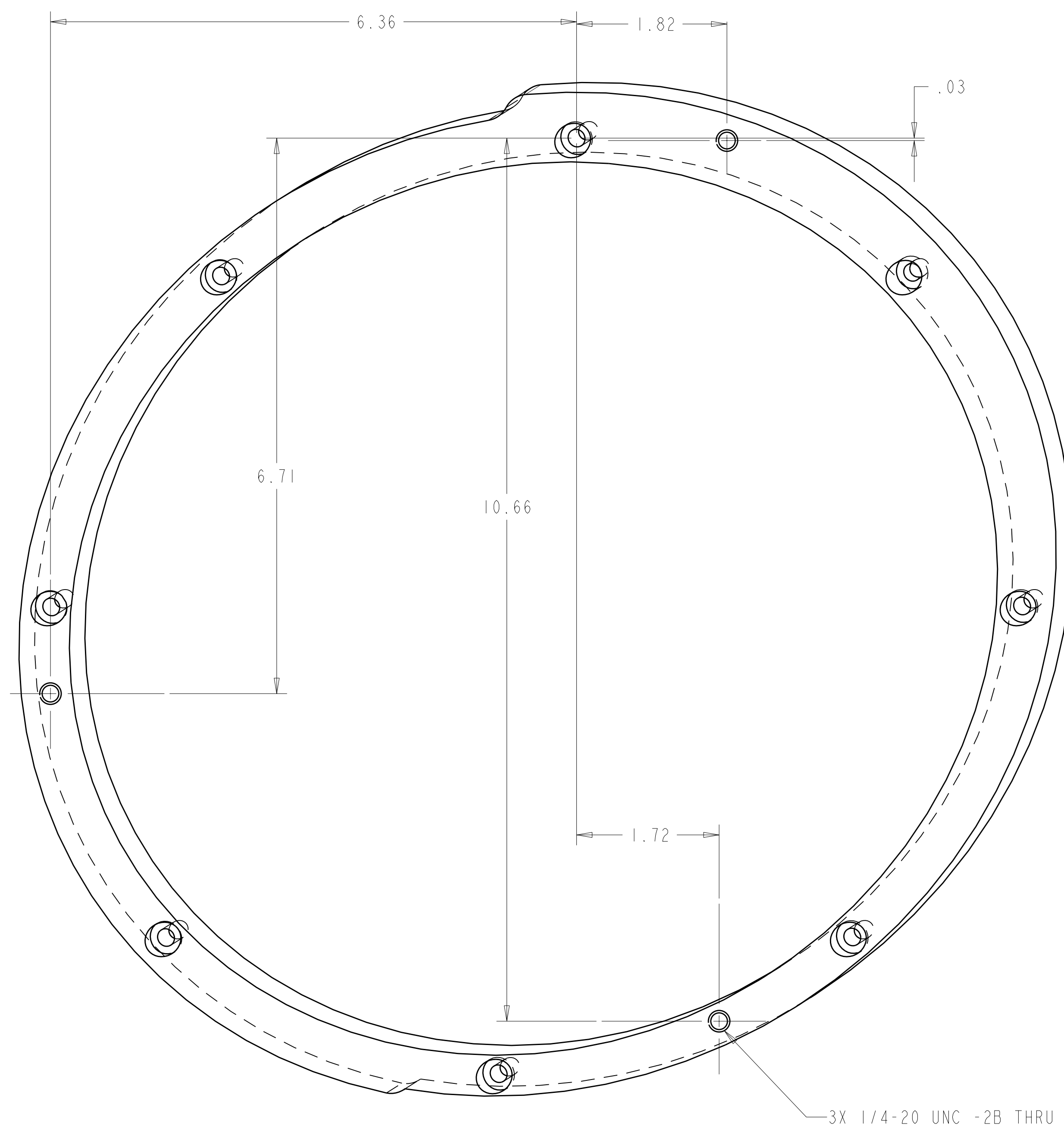

FLAT ORIENTATION

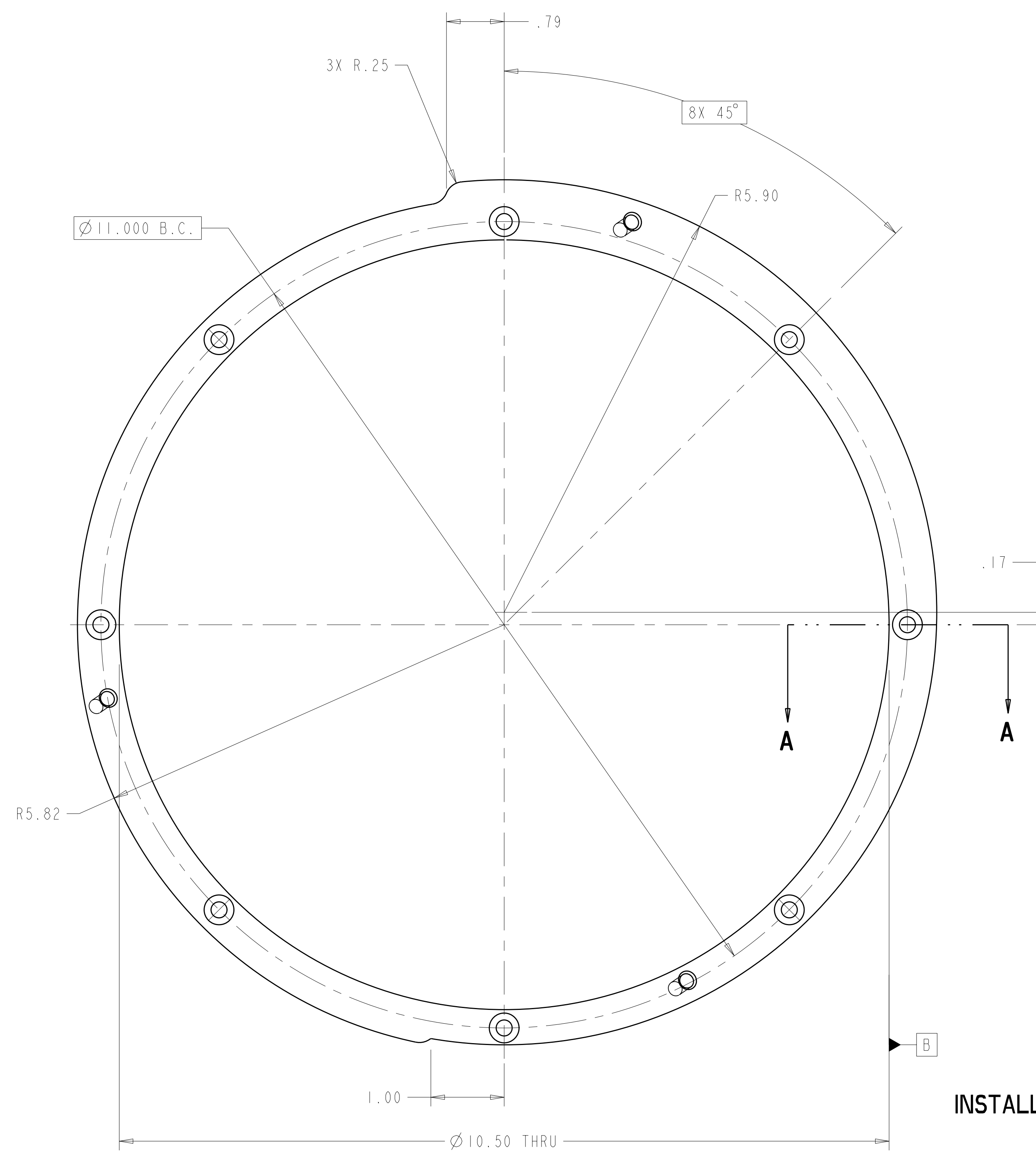
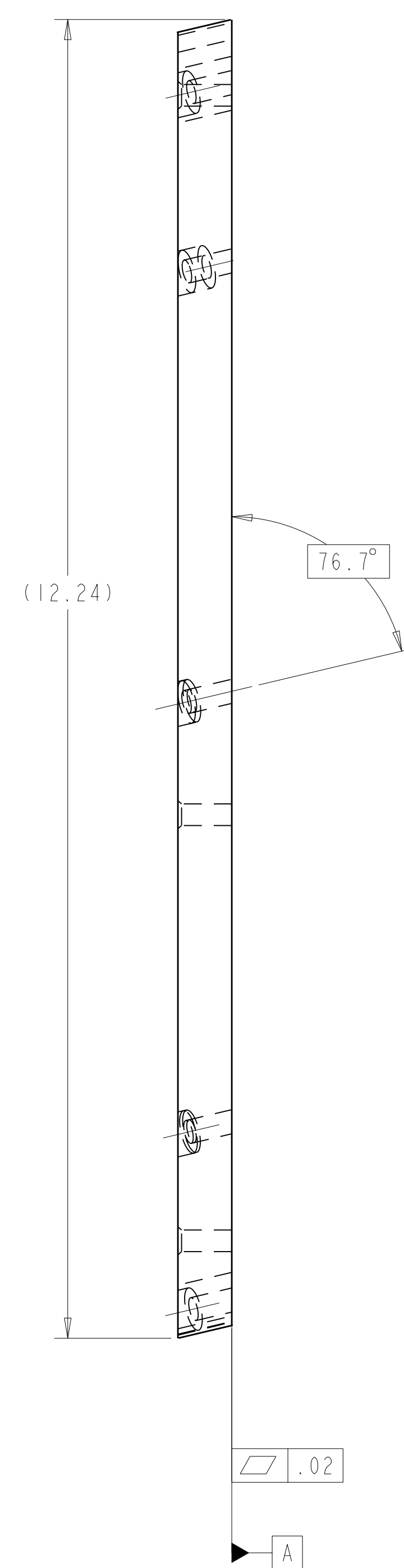

INSTALLED ORIENTATION

1 PORT 7 WINDING FORM SEAL OUTER PLATE 4
SCALE 1.000

AR	CAGE CODE	PART OR IDENTIFYING NO	NOMENCLATURE OR DESCRIPTION	MATERIAL	SPECIFICATION	FIND NO
4	AR	-1	PORT 5 WINDING FORM SEAL OUTER PLATE	GAROLITE	G-11	1
			← NEXT ASSEMBLY	PARTS LIST		

RELEASED FOR FABRICATION / INSTALLATION
PPPL Drafting:

NO REPRESENTATION OR WARRANTY, EXPRESSED OR IMPLIED, IS MADE AS TO THE ACCURACY, COMPLETENESS OR USEFULNESS OF THE INFORMATION OR STATEMENTS CONTAINED IN THESE DRAWINGS, OR THAT THE USE OR DISCLOSURE OF ANY INFORMATION, APPARATUS, METHOD OR PROCESS DISCLOSED IN THESE DRAWINGS MAY NOT INFRINGE PRIVATE RIGHTS OF OTHERS. NO LIABILITY IS ASSUMED WITH RESPECT TO THE USE OF, OR FOR DAMAGES RESULTING FROM THE USE OF, ANY INFORMATION, APPARATUS, METHOD OR PROCESS DISCLOSED IN THESE DRAWINGS. DRAWINGS MADE AVAILABLE FOR INFORMATION TO BIDDER ARE NOT TO BE USED FOR OTHER PURPOSES, AND ARE TO BE RETURNED UPON REQUEST OF THE FORWARDING CONTRACTOR.

P THIS DRAWING PRODUCED ON PRO-ENGINEER

REV	DESCRIPTION	BY	DATE	CHK	DEPT	DATE	PE	REQ	DATE	ORNL	DOE	DATE
0	ORIGINAL ISSUE	RAH	01/07	SP		01/07						
REVISION OR ISSUE PURPOSE												
REVISION APPROVAL												

SCALE NOTED		DES P. L. GORANSON 01/07
TOLERANCES UNLESS OTHERWISE SPECIFIED		DRW R. A. HURD 01/07
FRACTIONS		CHK S. PARSON 01/07
XX DECIMALS	±.01	SECT :
XXX DECIMALS	±.005	DEPT :
ANGLES	±0'15"	PE :
BREAK SHARP EDGES OR MAX		CR :
FINISH	±.025 UNLESS OTHERWISE SPECIFIED	PJ :
		RD :
		PPPL DRFT J. SIEGEL 01/07
		VERSION NO. 4
		PLANT ORNL
		BLDG 5700
		FL 3
		SHT 1
		OF 1
		TYPE I
		CLASS S
		U
		REV 0

UT-BATTELLE		Oak Ridge National Laboratory managed for the DEPARTMENT OF ENERGY under U.S. GOVERNMENT CONTRACT DE-AC05-00OR22725 UT-BATTELLE, LLC, Oak Ridge, Tennessee	
PROJECT NAME: NATIONAL COMPACT STELLARATOR EXPERIMENT			
PORT 7 WINDING FORM SEAL OUTER PLATE			
PLANT	BLDG	FL	SHT
ORNL	5700	3	1
RELEASE LEVEL	SE122-353		
Fabrication			