

- NOTES
1. DRAWING PREPARED IN ACCORDANCE WITH ASME Y14.100-2004.
  2. INTERPRET DIMENSIONS AND TOLERANCES PER ASME Y14.5M-1994.
  3. DIMENSIONS ARE IN INCHES.
  4. PART TO BE MANUFACTURED FROM PRO/ENGINEER DATA FILE SE122-354.PRT. DIMENSIONS SHOWN ARE FOR PART VERIFICATION ONLY.

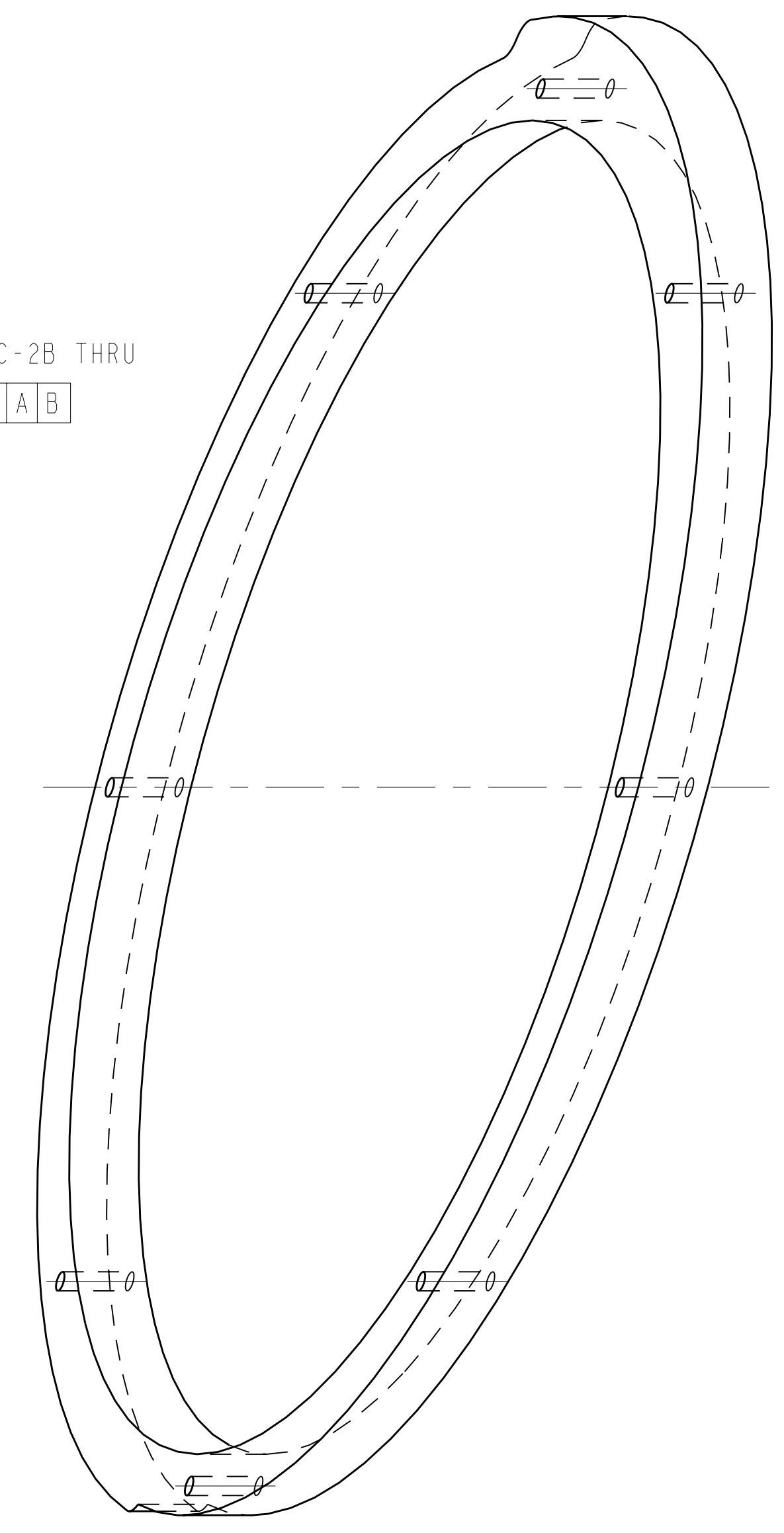
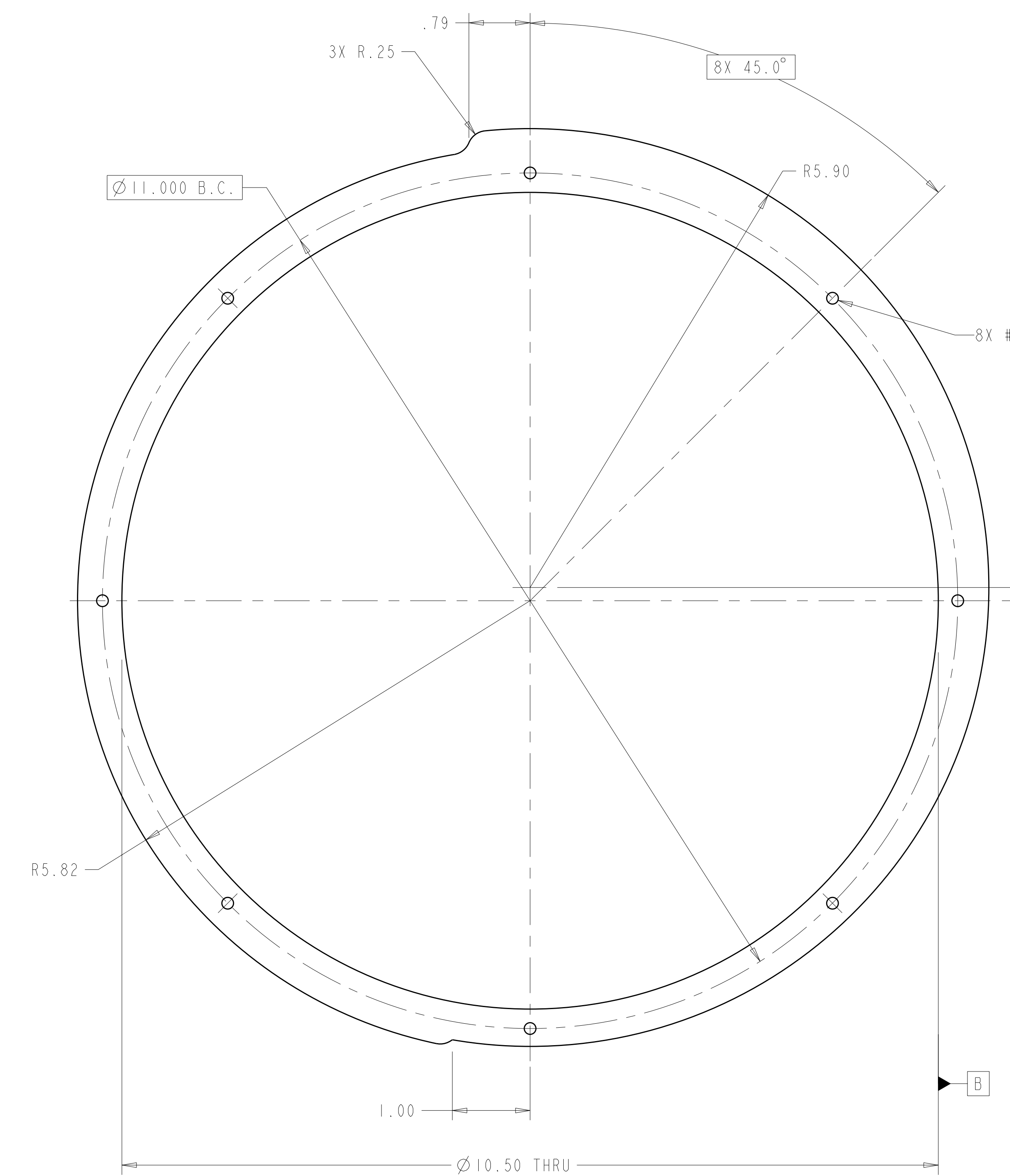
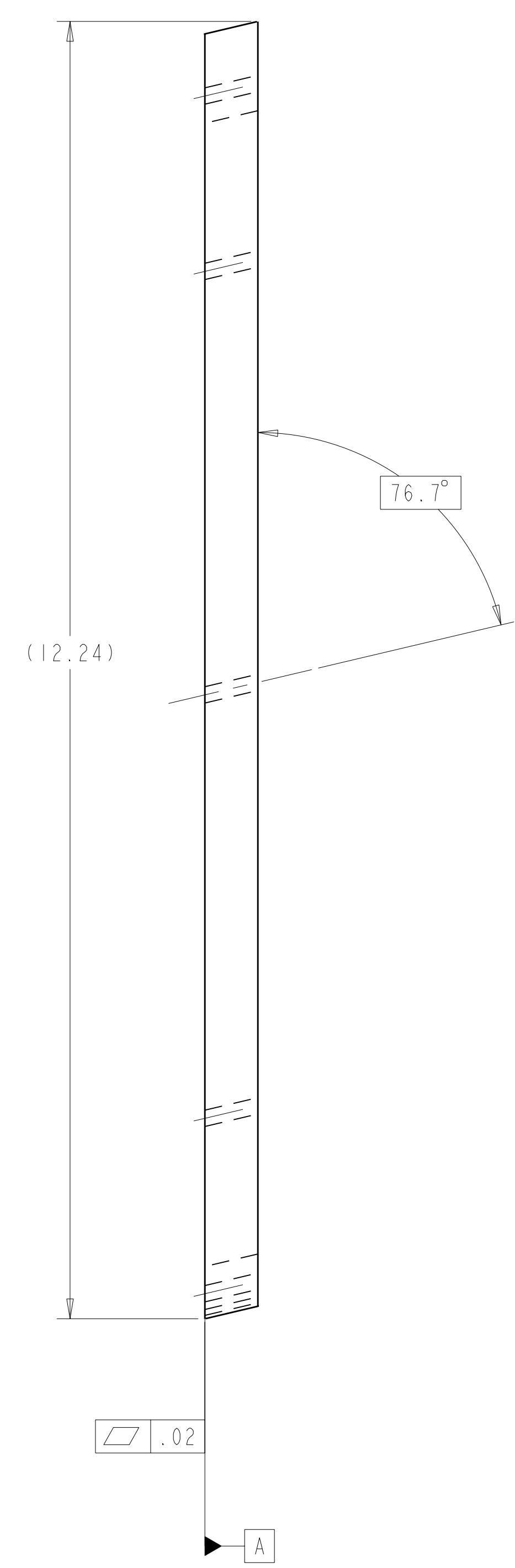
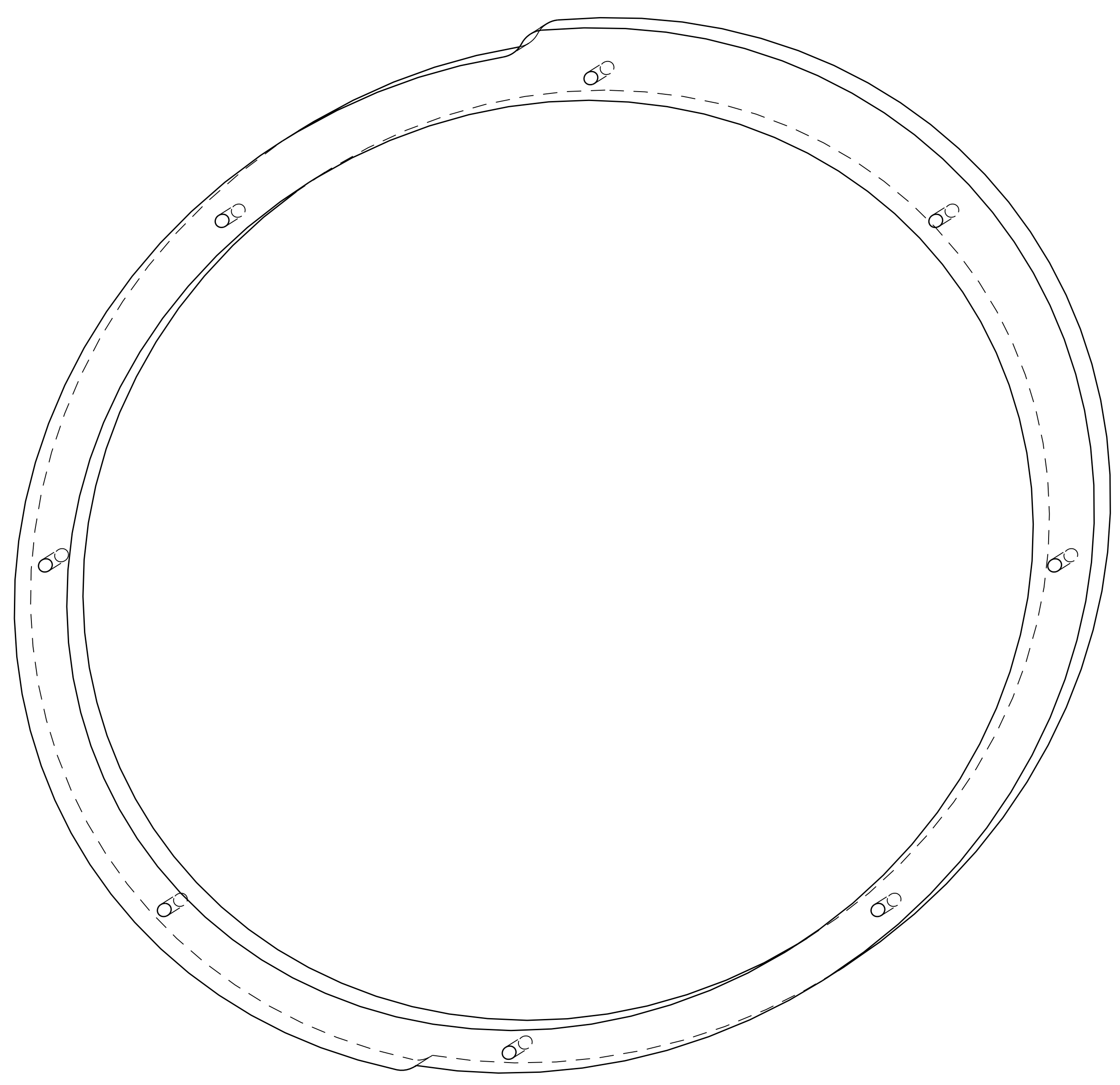
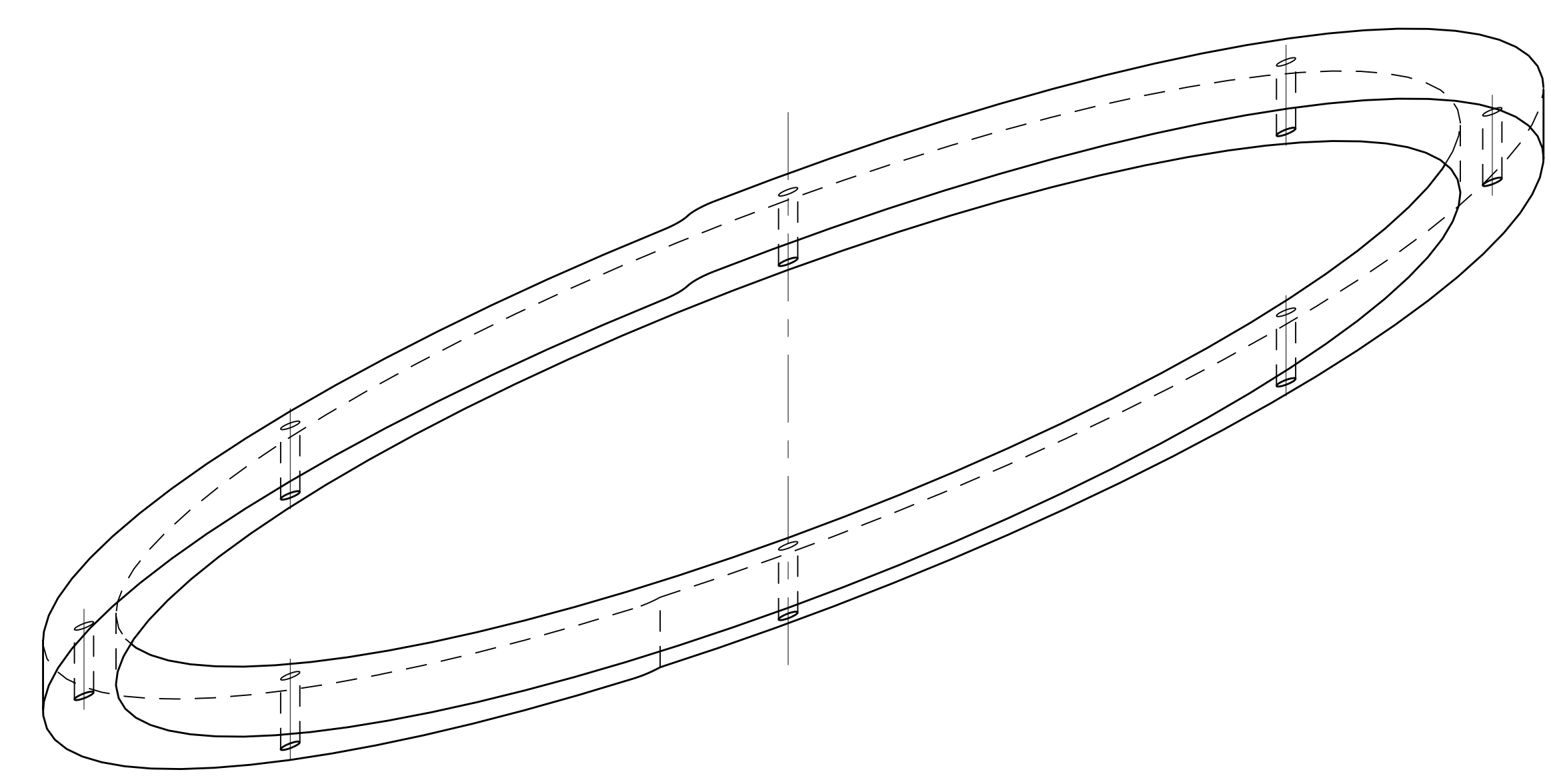
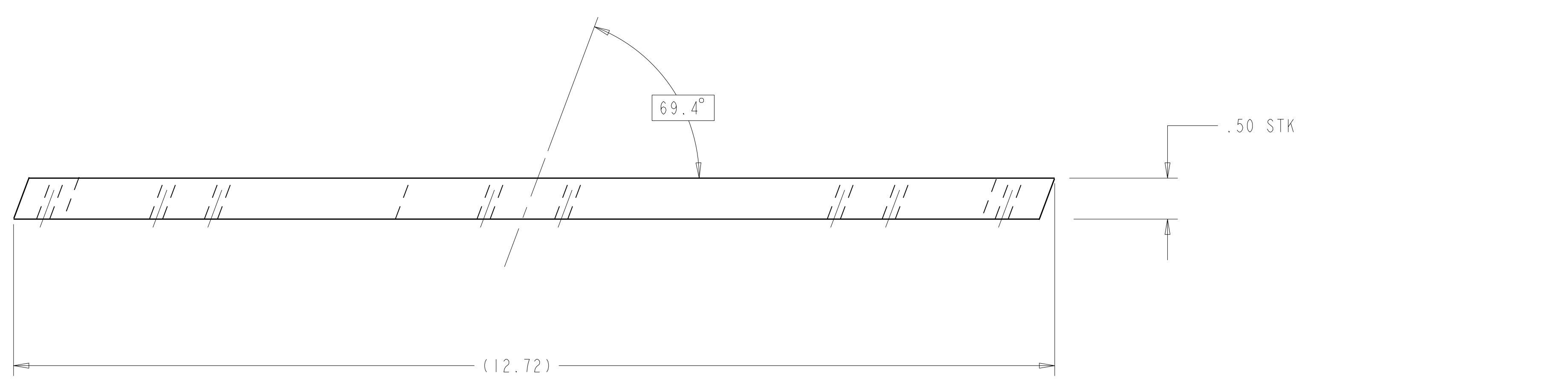

1 PORT 7 WINDING FORM SEAL INNER PLATE 4  
SCALE 1:1.000

AR	CAGE CODE	PART OR IDENTIFYING NO	NOMENCLATURE OR DESCRIPTION	MATERIAL	SPECIFICATION	FIND NO
4	AR	-1	PORT 7 WINDING FORM SEAL INNER PLATE	GAROLITE	G-11	1
			NEXT ASSEMBLY	PARTS LIST		

**RELEASED FOR FABRICATION / INSTALLATION**  
 PPPL Drafting:

NO REPRESENTATION OR WARRANTY, EXPRESSED OR IMPLIED, IS MADE AS TO THE ACCURACY, COMPLETENESS OR USEFULNESS OF THE INFORMATION OR STATEMENTS CONTAINED IN THESE DRAWINGS, OR THAT THE USE OR DISCLOSURE OF ANY INFORMATION, APPARATUS, METHOD OR PROCESS DISCLOSED IN THESE DRAWINGS MAY NOT INFRINGE PRIVATE RIGHTS OF OTHERS. NO LIABILITY IS ASSUMED WITH RESPECT TO THE USE OF, OR FOR DAMAGES RESULTING FROM THE USE OF, ANY INFORMATION, APPARATUS, METHOD OR PROCESS DISCLOSED IN THESE DRAWINGS. DRAWINGS MADE AVAILABLE FOR INFORMATION TO BIDDER ARE NOT TO BE USED FOR OTHER PURPOSES, AND ARE TO BE RETURNED UPON REQUEST OF THE FORWARDING CONTRACTOR.

**P** THIS DRAWING PRODUCED ON PRO-ENGINEER

REV	DESCRIPTION	BY	DATE	CHK	DEPT	DATE	PE	REQ	DATE	ORNL	DOE	DATE
0	ORIGINAL ISSUE	RAH	01/07	SP		01/07						
REVISION OR ISSUE PURPOSE												
REVISION APPROVAL												

SCALE NOTED	DES P. L. GORANSON 01/07
TOLERANCES UNLESS OTHERWISE SPECIFIED	DRW R. A. HURD 01/07
FRACTIONS	CHK S. PARSON 01/07
XX DECIMALS ±.01	DEPT :
XXX DECIMALS ±.005	FE :
ANGLES ±0°15'	CR :
BREAK SHARP EDGES OR MAX	PJ :
FINISH .125 UNLESS OTHERWISE SPECIFIED	REQ :
	REO :
	PPPL DRFT J. SIEGEL 01/07
	VERSION NO. 4
	PLANT ORNL
	BLDG 5700
	FL 3
	SHT 1
	OF 1
	TYPE I
	CLASS S
	U
	REV 0

Oak Ridge National Laboratory managed for the DEPARTMENT OF ENERGY under U.S. GOVERNMENT CONTRACT DE-AC05-00OR22725 UT-BATTELLE, LLC, Oak Ridge, Tennessee PROJECT NAME:	
<b>NATIONAL COMPACT STELLARATOR EXPERIMENT</b>	
<b>PORT 7 WINDING FORM SEAL INNER PLATE</b>	
VERSION NO. 4 PLANT ORNL BLDG 5700 FL 3 SHT 1 OF 1 TYPE I CLASS S U REV 0	SE122-354