

ISOMETRIC VIEW  
SCALE 1.000

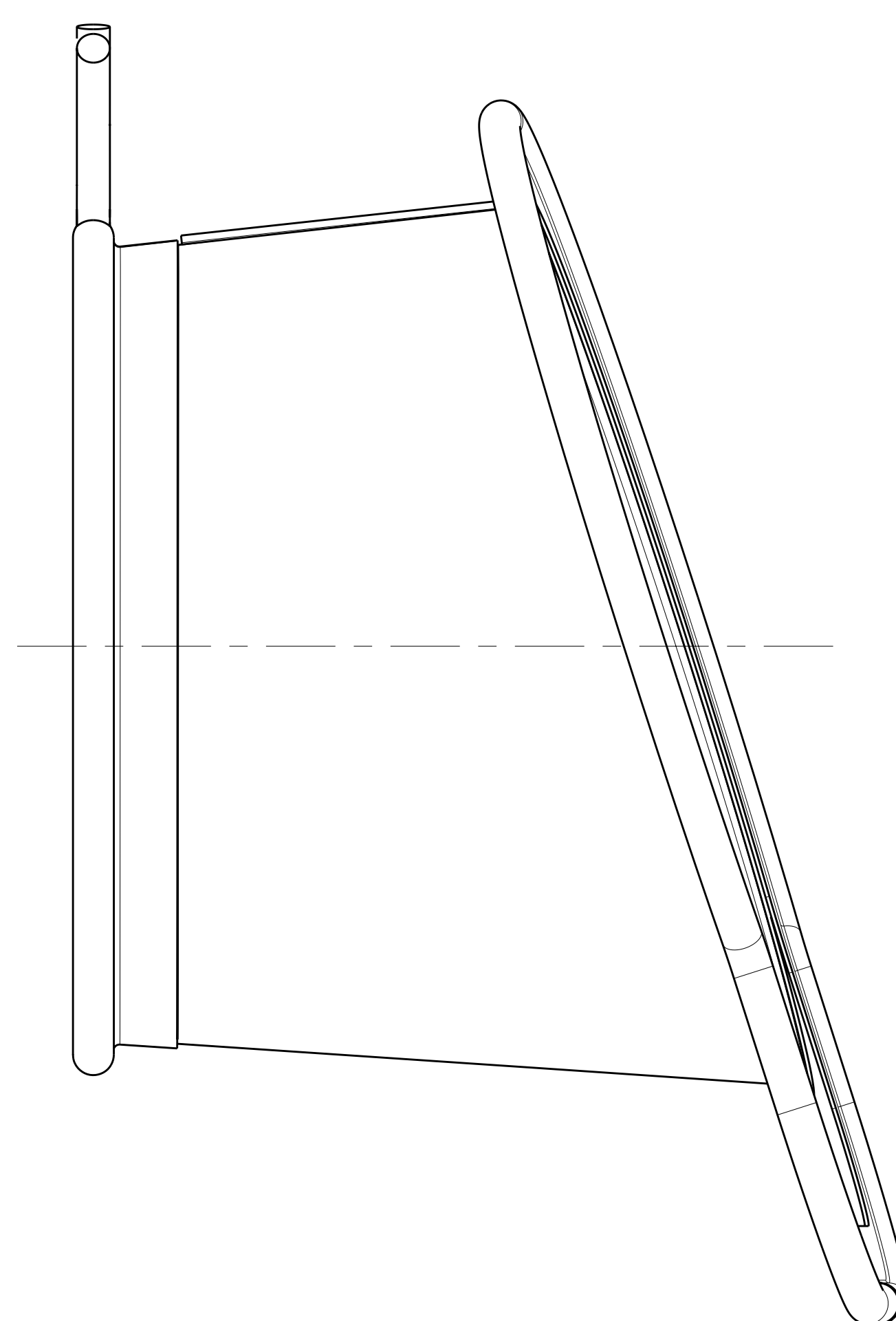

-1 PORT II WINDING FORM SEAL BOOT ASSEMBLY  
SCALE 1.000

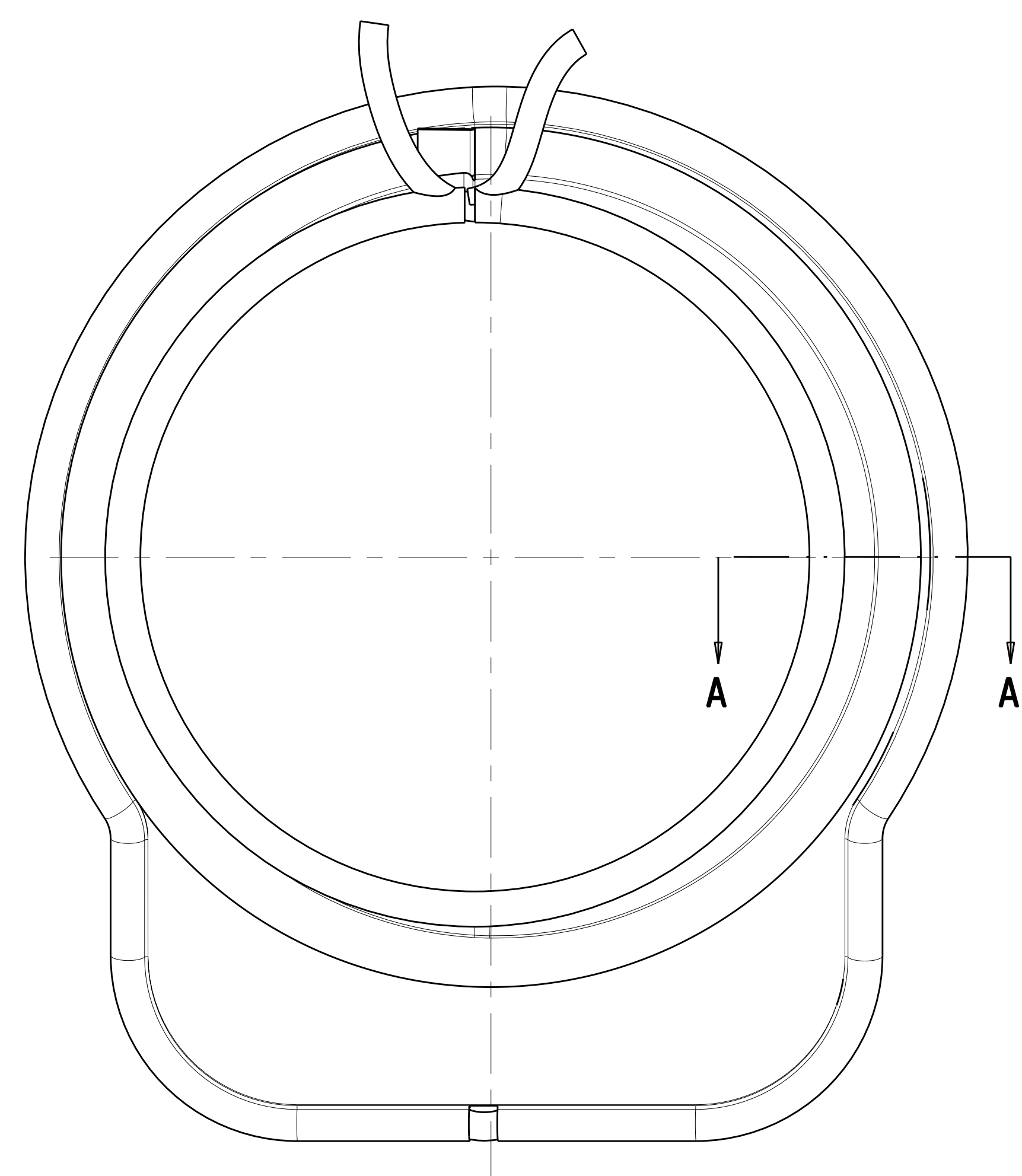
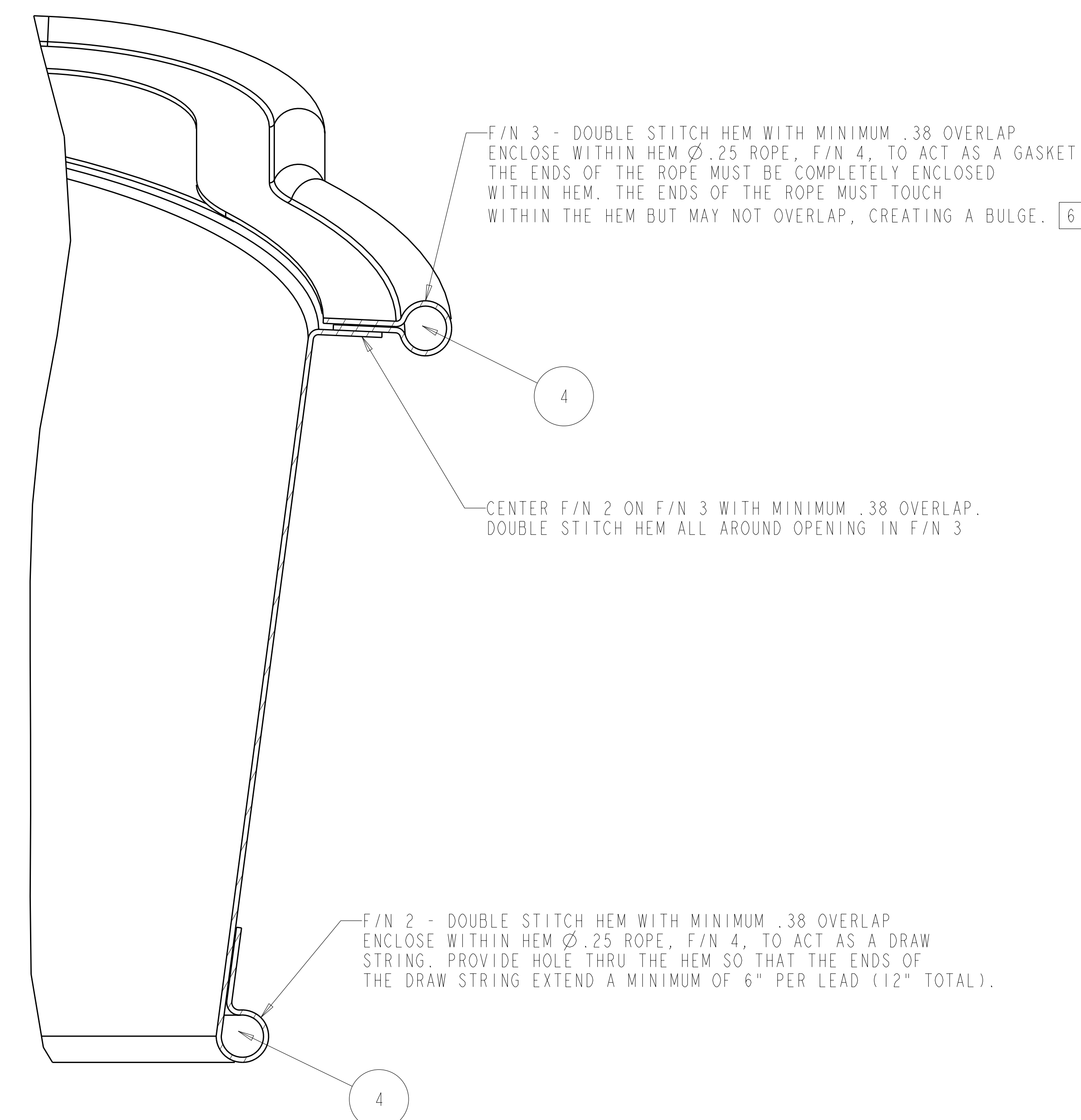

SECTION A-A  
SCALE 2.000

**RELEASED FOR  
FABRICATION / INSTALLATION**  
PPPL Drafting:

REV	DESCRIPTION	BY	DATE	CHK	DEPT	DATE	PE	REQ	DATE	ORNL	DOE	DATE
0	ORIGINAL ISSUE	RAH	01/01	SP		01/01						

CAGE CODE	PART OR IDENTIFYING NO	NOMENCLATURE OR DESCRIPTION	MATERIAL	SPECIFICATION	FIND NO
4 6	1	-4	Ø.25 ROPE	NCSX-PRL-12-001	4
4 6	1	-3	PORT II WINDING FORM SEAL BOOT BACK	NCSX-PRL-12-001	3
4	1	-2	PORT II WINDING FORM SEAL BOOT CONE	NCSX-PRL-12-001	2
AR	X	-1	PORT II WINDING FORM SEAL BOOT ASSEMBLY		1

PARTS LIST

NO REPRESENTATION OR WARRANTY, EXPRESSED OR IMPLIED, IS MADE AS TO THE ACCURACY, COMPLETENESS OR USEFULNESS OF THE INFORMATION OR STATEMENTS CONTAINED IN THESE DRAWINGS, OR THAT THE USE OR DISCLOSURE OF ANY INFORMATION, APPARATUS, METHOD OR PROCESS DISCLOSED IN THESE DRAWINGS MAY NOT INFRINGE PRIVATE RIGHTS OF OTHERS. NO LIABILITY IS ASSUMED WITH RESPECT TO THE USE OF, OR FOR DAMAGES RESULTING FROM THE USE OF, ANY INFORMATION, APPARATUS, METHOD OR PROCESS DISCLOSED IN THESE DRAWINGS. DRAWINGS MADE AVAILABLE FOR PURPOSES, AND ARE TO BE RETURNED UPON REQUEST OF THE FORWARDING CONTRACTOR.

**P** THIS DRAWING PRODUCED ON PRO-ENGINEER

SCALE NOTED

TOLERANCES UNLESS OTHERWISE SPECIFIED  
FRACTIONS :  
XX DECIMALS ±.01  
XXX DECIMALS ±.005  
ANGLES ±0°15'  
BREAK SHARP EDGES OR MAX  
FINISH : .125 UNLESS OTHERWISE SPECIFIED

DES P. L. GORANSON 01/07  
DRW R. A. HURD 01/07  
CHK S. PARSON 01/07  
SECT :  
DEPT :  
PE :  
CR :  
PJ :  
RD :  
PPPL DRFT J. SIEGEL 01/07  
VERSION NO. 5  
PLANT ORNL  
BLDG 5700  
FL 3  
SHT 1  
OF 2  
TYPE A  
CLASS U  
RELEASE LEVEL Fabrication  
SE122-371  
REV 0

Oak Ridge National Laboratory managed for the DEPARTMENT OF ENERGY under U.S. GOVERNMENT contract DE-AC05-00OR22725 UT-BATTELLE, LLC. Oak Ridge, Tennessee

NATIONAL COMPACT STELLARATOR EXPERIMENT

PORT II WINDING FORM SEAL BOOT ASSEMBLY

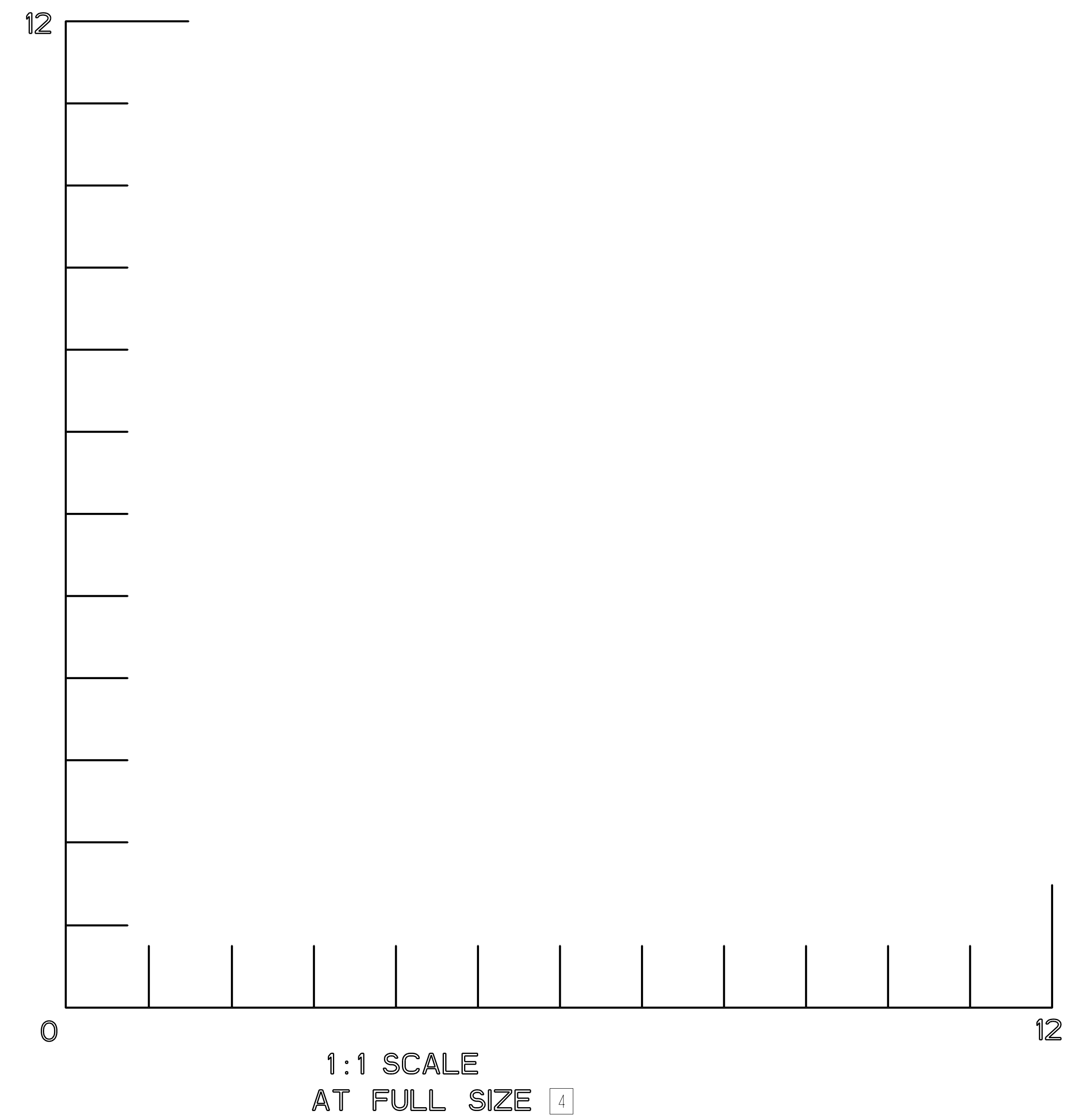
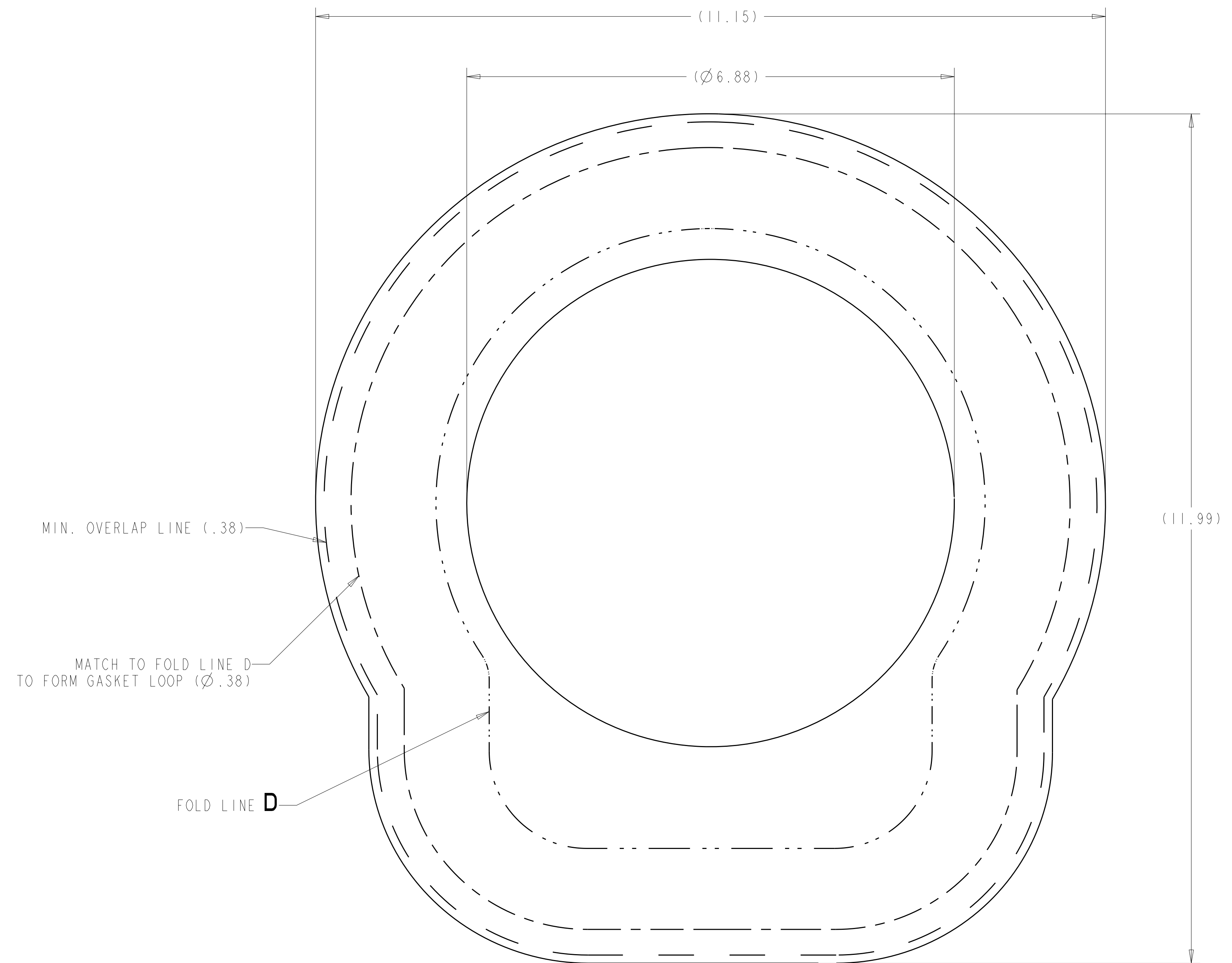
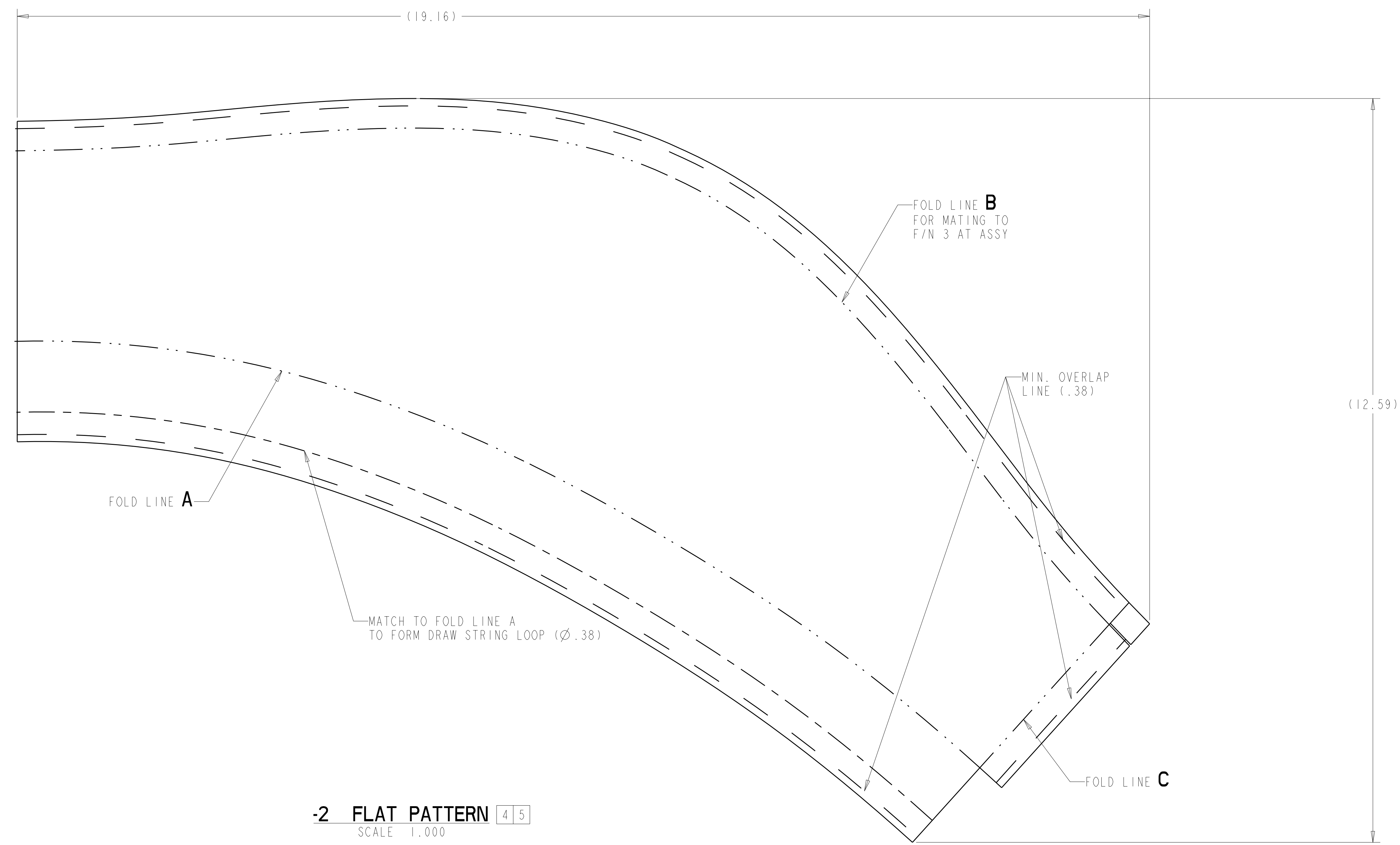

**RELEASED FOR  
FABRICATION / INSTALLATION**  
PPPL Drafting:

<small>Oak Ridge National Laboratory managed for the DEPARTMENT OF ENERGY under U.S. GOVERNMENT contract DE-AC05-00OR22725 UT-BATTELLE, LLC. Oak Ridge, Tennessee</small>									
<b>UT-BATTELLE</b>									
PROJECT NAME <b>NATIONAL COMPACT STELLARATOR EXPERIMENT</b>									
<b>PORT II WINDING FORM SEAL BOOT ASSEMBLY</b>									
VERSION NO. 5	PLANT ORNL	BLDG 5700	FL 3	SHT OF 2	TYPE 2	CLASS A	REV U		
RELEASE LEVEL Fabrication		SE122-371							