

- NOTES
1. DRAWING PREPARED IN ACCORDANCE WITH ASME Y14.100-2004.
 2. INTERPRET DIMENSIONS AND TOLERANCES PER ASME Y14.5M-1994.
 3. DIMENSIONS ARE IN INCHES
 - 4 PART TO BE MANUFACTURED FROM PRO/ENGINEER DATA FILE SE122-386.PRT. DIMENSIONS SHOWN ARE FOR PART VERIFICATION ONLY.

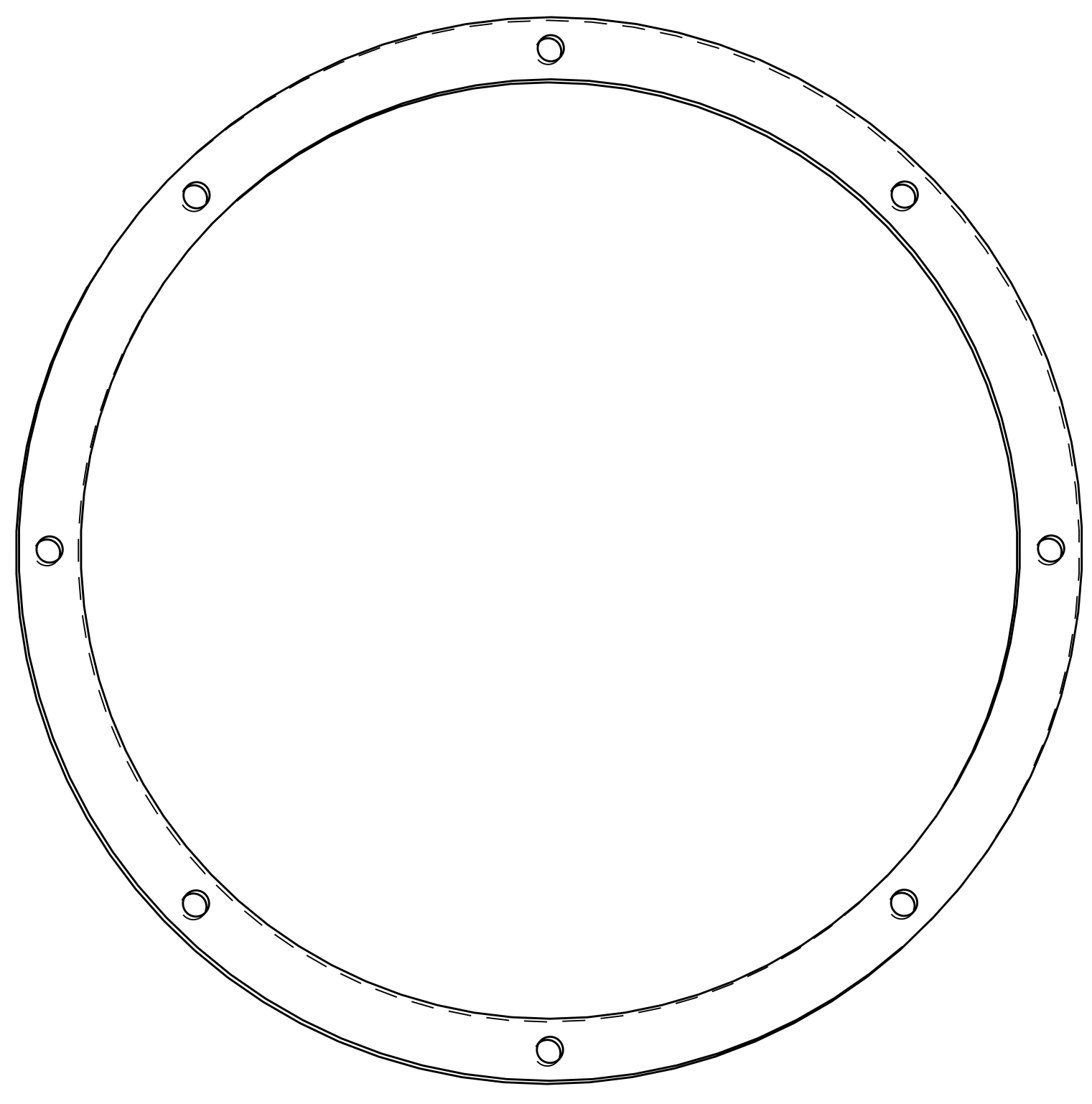

FLAT ORIENTATION

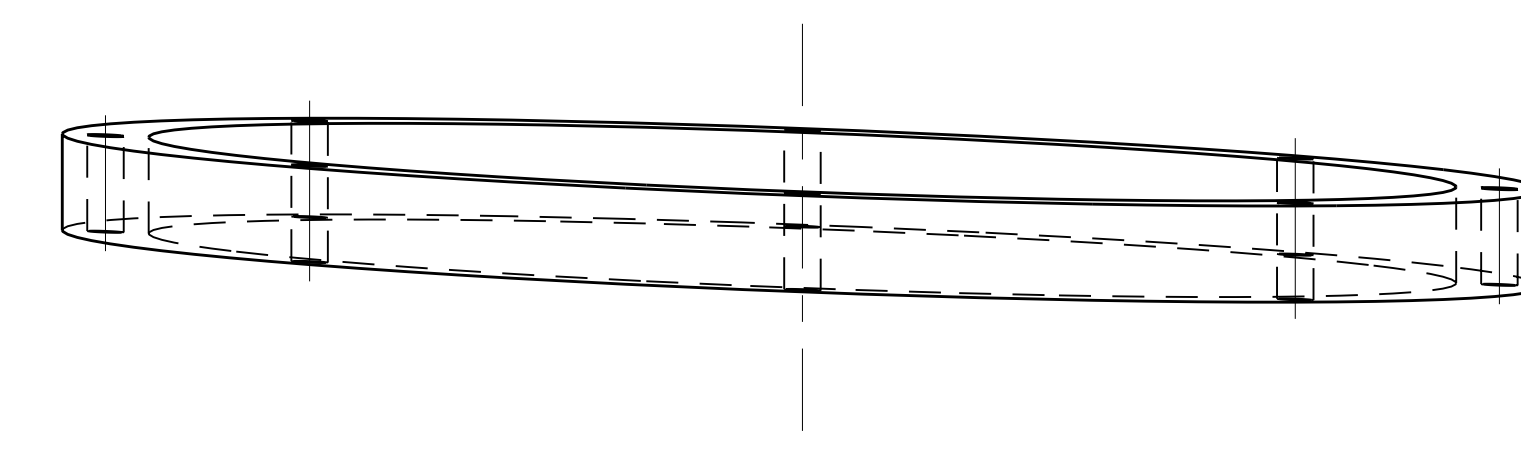
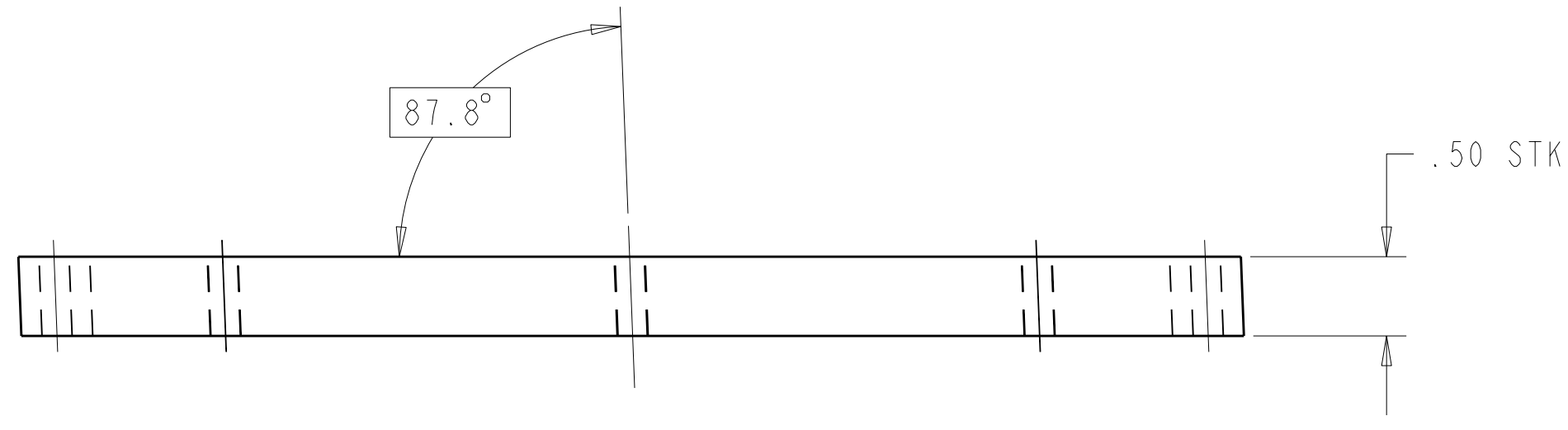
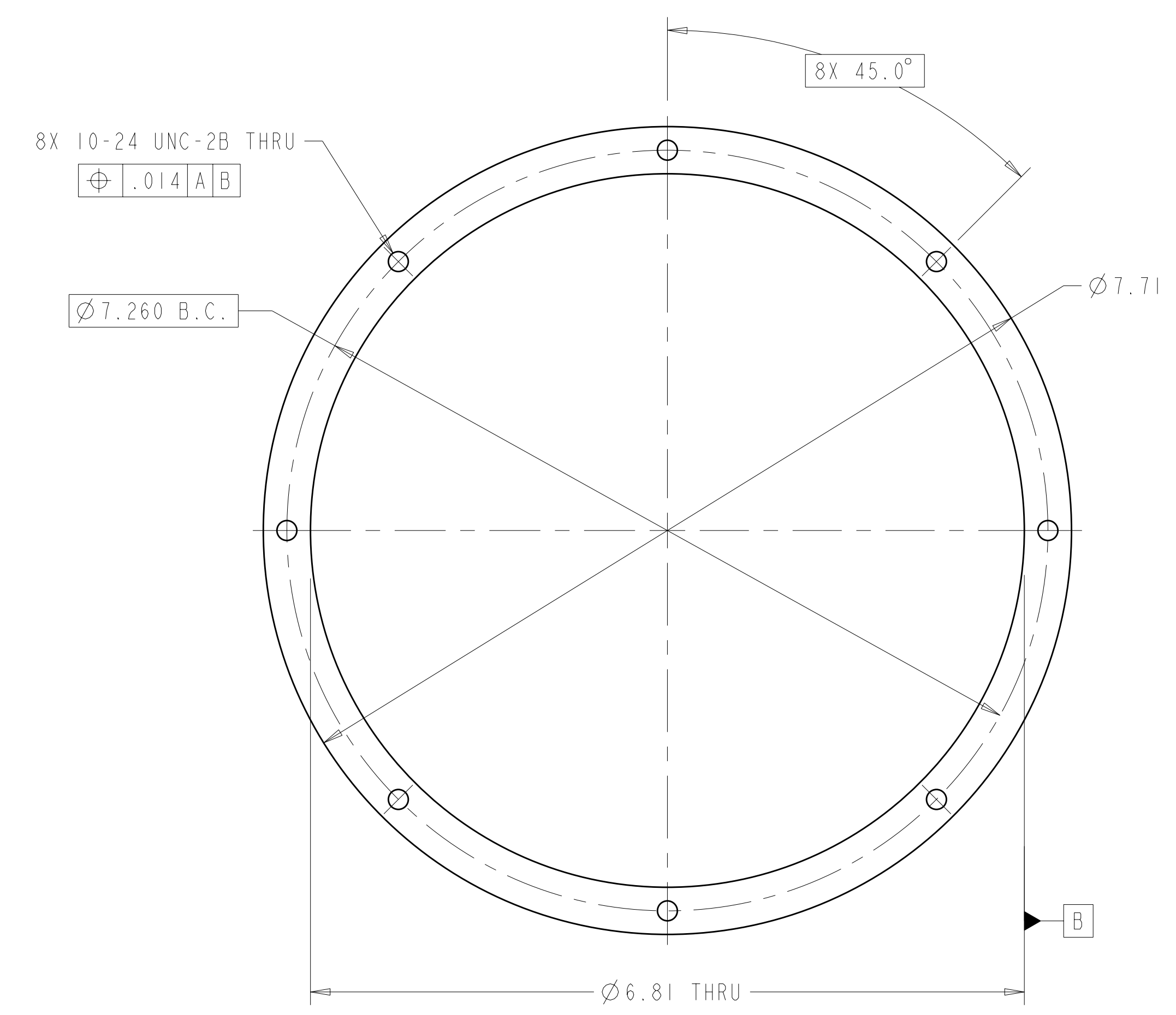
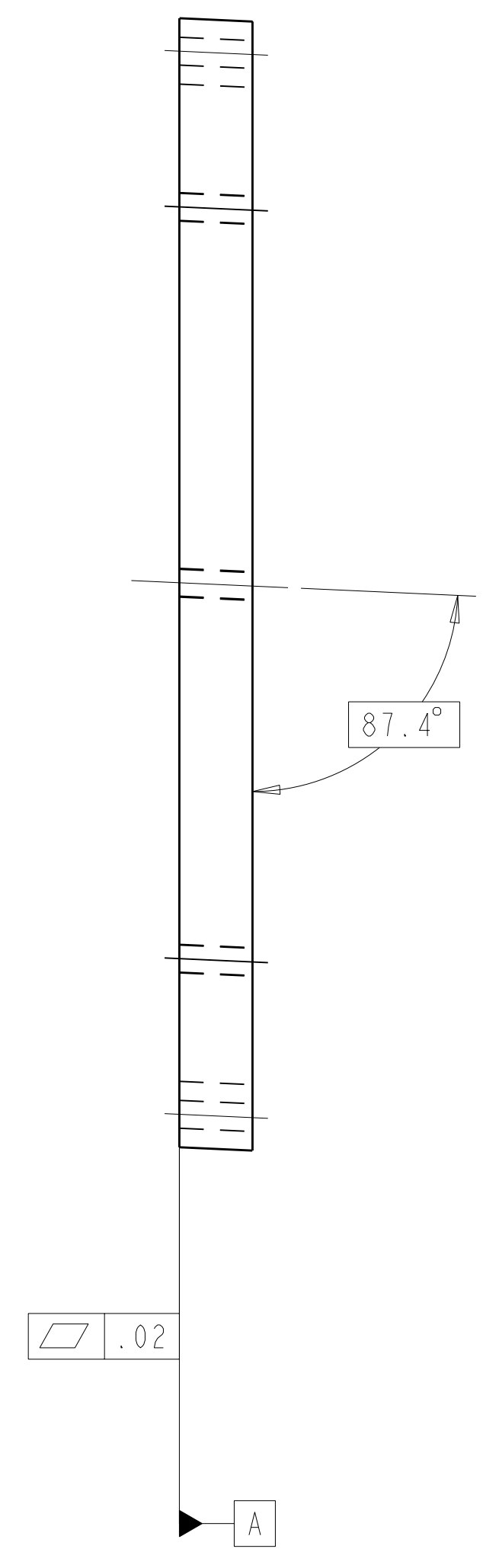

INSTALLED ORIENTATION

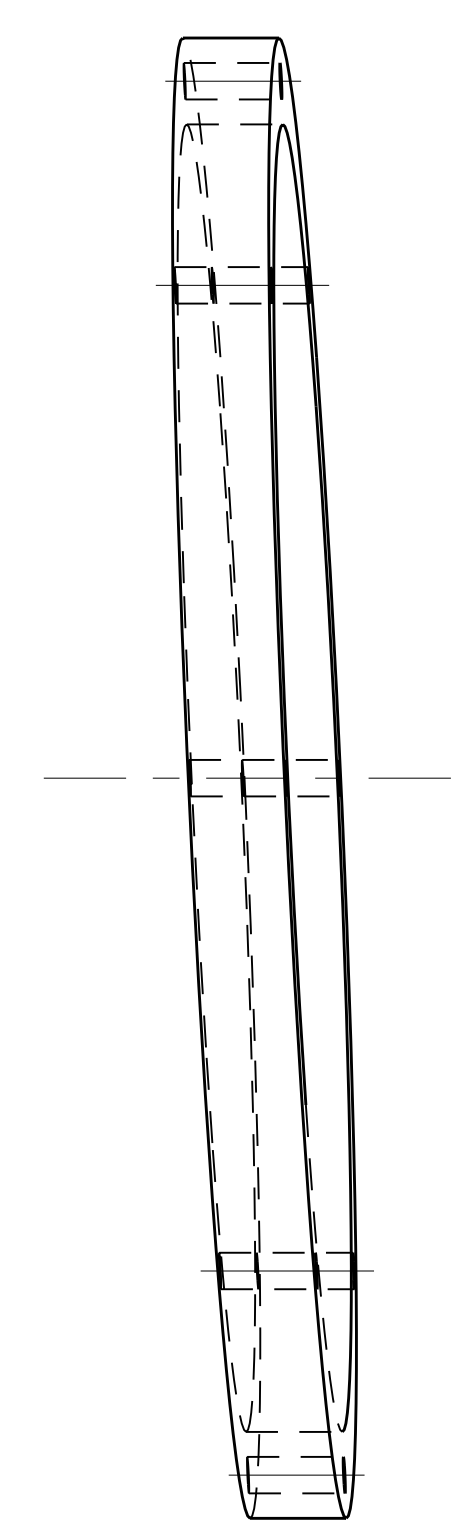

RELEASED FOR FABRICATION / INSTALLATION
PPPL Drafting:

-1 PORT 8 WINDING FORM SEAL INNER PLATE 4
SCALE 0.083

REV	DESCRIPTION	BY	DATE	CHK	DEPT	DATE	PE	REQ	DATE	ORNL	DOE	DATE
0	ORIGINAL ISSUE	MTR	01/07	SP		01/07						

REV	DESCRIPTION	BY	DATE	CHK	DEPT	DATE	PE	REQ	DATE	ORNL	DOE	DATE
0	ORIGINAL ISSUE	MTR	01/07	SP		01/07						

DES	PL GORANSON	01/07	DRW	MT BROWN	01/07	CHK	S PARSON	01/07					
SECT	:	:	DEPT	:	:	PE	:	:					
FRACTIONS	XX	±.01	XXX DECIMALS	±.005	CR	±0°15'	PJ	:					
ANGLES	±0°15'	REO	:	:	FINISH	±.025 UNLESS OTHERWISE SPECIFIED	PPPL DRFT	J SIEGEL					
VERSION NO.	3	PLANT	ORNL	BLDG	5700	FL	3	SHT	1	OF	1	TYPE	CLASS
RELEASE LEVEL	Fabrication	SE122-386	REV	0									

NO REPRESENTATION OR WARRANTY, EXPRESSED OR IMPLIED, IS MADE AS TO THE ACCURACY, COMPLETENESS OR USEFULNESS OF THE INFORMATION OR STATEMENTS CONTAINED IN THESE DRAWINGS, OR THAT THE USE OR DISCLOSURE OF ANY INFORMATION, APPARATUS, METHOD OR PROCESS DISCLOSED IN THESE DRAWINGS MAY NOT INFRINGE PRIVATE RIGHTS OF OTHERS. NO LIABILITY IS ASSUMED WITH RESPECT TO THE USE OF, OR FOR DAMAGES RESULTING FROM THE USE OF, ANY INFORMATION, APPARATUS, METHOD OR PROCESS DISCLOSED IN THESE DRAWINGS. DRAWINGS MADE AVAILABLE FOR INFORMATION TO BIDDER ARE NOT TO BE USED FOR OTHER PURPOSES, AND ARE TO BE RETURNED UPON REQUEST OF THE FORWARDING CONTRACTOR.

P THIS DRAWING PRODUCED ON PRO-ENGINEER