

- NOTES
- DRAWING PREPARED IN ACCORDANCE WITH ASME Y14.100-2004.
  - INTERPRET DIMENSIONS AND TOLERANCES PER ASME Y14.5M-1994.
  - DIMENSIONS ARE IN INCHES.
  - FLAT PART TO BE MANUFACTURED FROM PRO/ENGINEER DATA FILE SE122-404-FLAT.PRT. DIMENSIONS SHOWN ARE FOR PART VERIFICATION ONLY.
  - MAGNETIC PERMEABILITY NOT TO EXCEED 1.02 AS TESTED BY A SEVERN INDICATOR. AVAILABLE FROM:  
SEVERN ENGINEERING  
AUBURN, ALABAMA 36830  
WWW.SEVERENGINEERING.COM

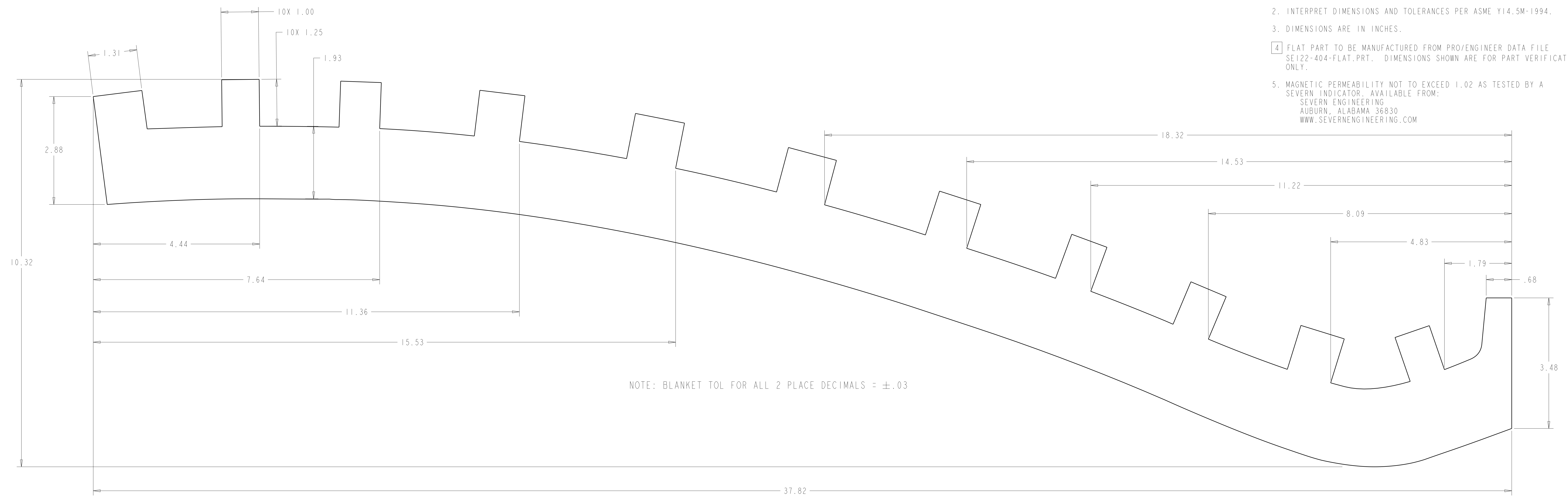

NOTE: BLANKET TOL FOR ALL 2 PLACE DECIMALS = ±.03

FLAT PATTERN WITH BEND LINES [4]  
SCALE 1.00

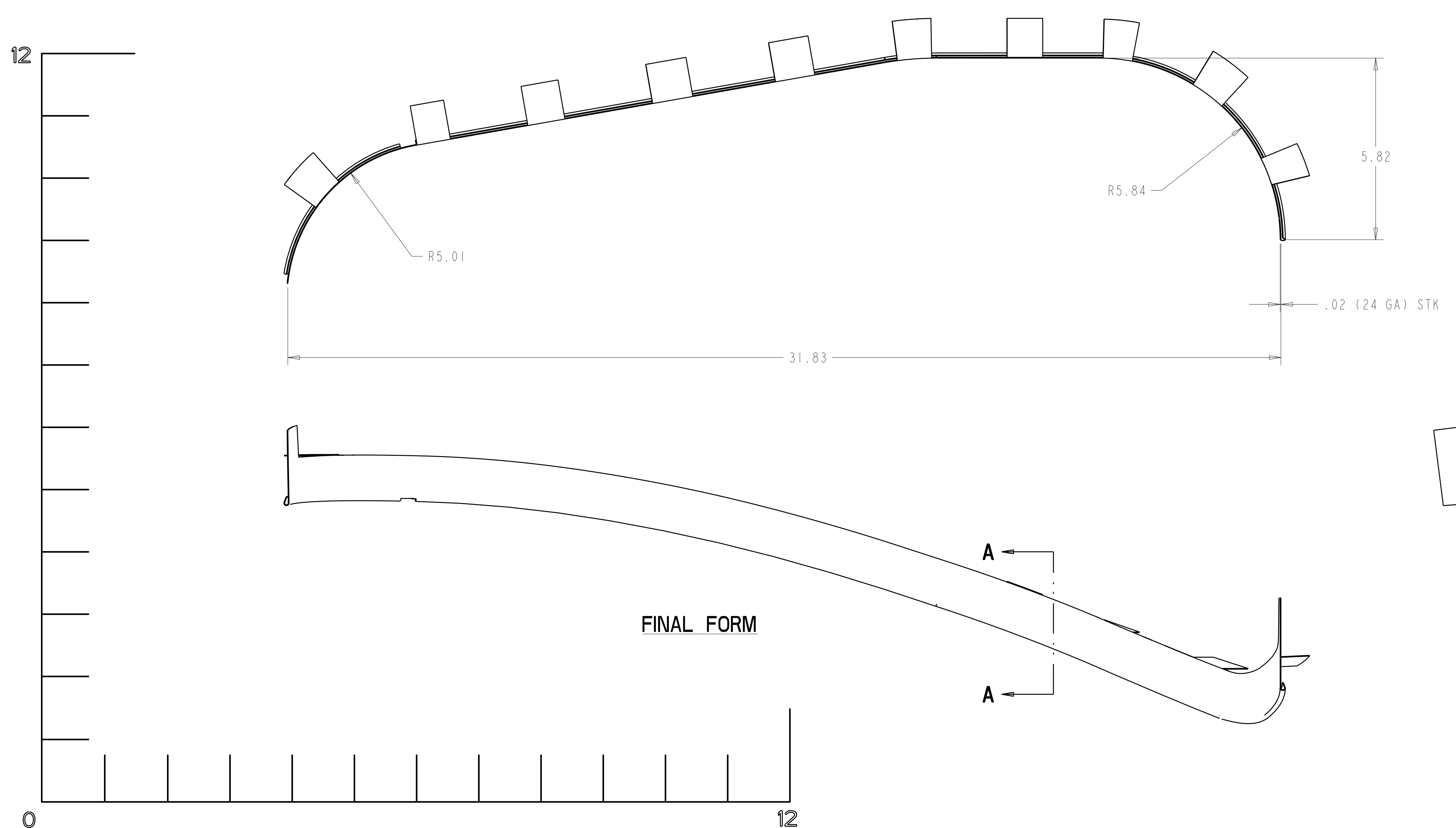

1:1 SCALE  
AT FULL SIZE

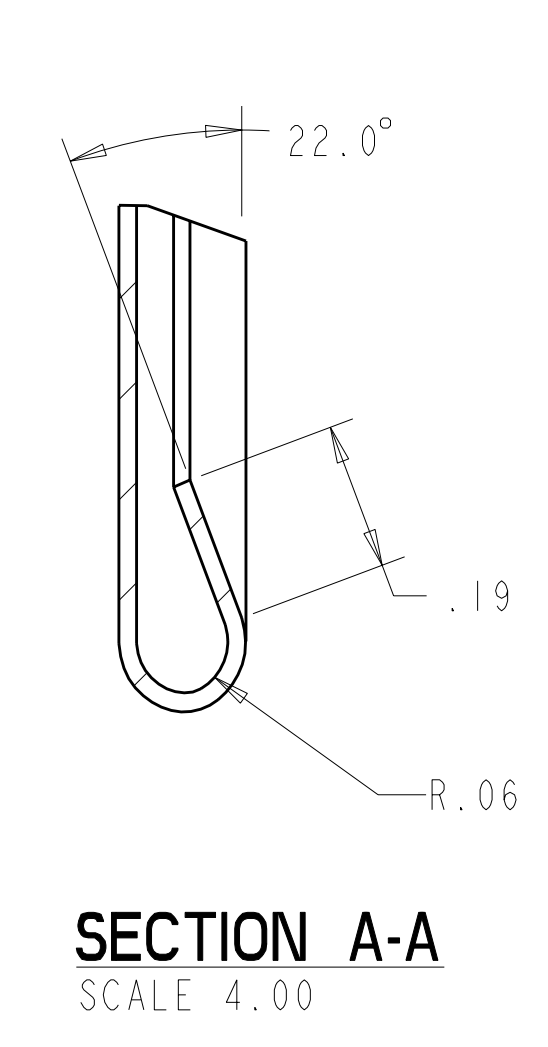

SECTION A-A  
SCALE 4.00

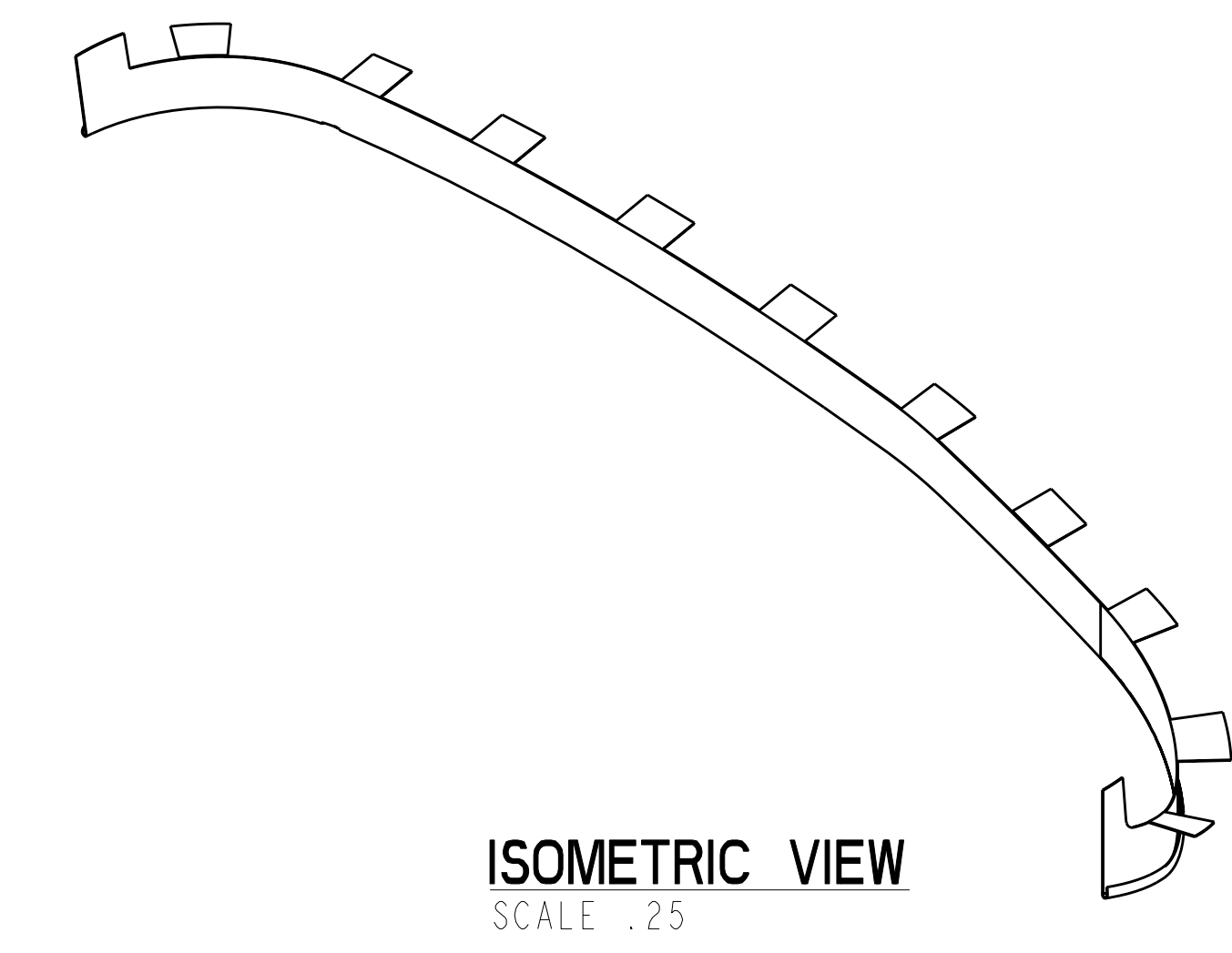

ISOMETRIC VIEW  
SCALE .25

-1 PORT 12 SEAL CUFF RIGHT SIDE [4]  
SCALE .50

**RELEASED FOR  
FABRICATION / INSTALLATION**  
PPPL Drafting:

REV	DESCRIPTION	BY	DATE	CHK	DEPT	DATE	PE	REQ	DATE	ORNL	DOE	DATE
0	ORIGINAL ISSUE	GWM	01/07	SP		01/07						

CAGE CODE	PART OR IDENTIFYING NO	NOMENCLATURE OR DESCRIPTION	MATERIAL	SPECIFICATION	FIND NO
SE122-404-1	-1	PORT 12 SEAL CUFF RIGHT SIDE	24 GA (.02 THK) 316L SST	ASTM A240	1

← NEXT ASSEMBLY

PARTS LIST

NO REPRESENTATION OR WARRANTY, EXPRESSED OR IMPLIED, IS MADE AS TO THE ACCURACY, COMPLETENESS OR USEFULNESS OF THE INFORMATION OR STATEMENTS CONTAINED IN THESE DRAWINGS, OR THAT THE USE OR DISCLOSURE OF ANY INFORMATION, APPARATUS, METHOD OR PROCESS DISCLOSED IN THESE DRAWINGS MAY NOT INFRINGE PRIVATE RIGHTS OF OTHERS. NO LIABILITY IS ASSUMED WITH RESPECT TO THE USE OF, OR FOR DAMAGES RESULTING FROM THE USE OF, ANY INFORMATION, APPARATUS, METHOD OR PROCESS DISCLOSED IN THESE DRAWINGS. DRAWINGS MADE AVAILABLE FOR INFORMATION TO BIDDER ARE NOT TO BE USED FOR OTHER PURPOSES, AND ARE TO BE RETURNED UPON REQUEST OF THE FORWARDING CONTRACTOR.

**P** THIS DRAWING PRODUCED ON PRO-ENGINEER

REV	DESCRIPTION	BY	DATE	CHK	DEPT	DATE	PE	REQ	DATE	ORNL	DOE	DATE
0	ORIGINAL ISSUE	GWM	01/07	SP		01/07						

SCALE	NOTED	DES	PL	DRW	CHK	SECT	DEPT	PE	CR	PJ	REQ	FINISH
		PL GORANSON		GW MCGINNIS	S PARSON							

VERSION NO.	PLANT	BLDG	FL	SHT	OF	TYPE	CLASS
5	ORNL	5700	3	1	1	S	U

RELEASE LEVEL	SEI22-404	REV
Fabrication		0

Oak Ridge National Laboratory  
managed for the DEPARTMENT OF ENERGY under  
U.S. GOVERNMENT CONTRACT DE-AC05-00OR22725  
UT-BATTELLE, LLC, Oak Ridge, Tennessee  
PROJECT NAME:  
**NATIONAL COMPACT STELLARATOR EXPERIMENT**  
**PORT 12 SEAL CUFF RIGHT SIDE**