

SECTION A-A
SCALE 4.00

- NOTES
1. DRAWING PREPARED IN ACCORDANCE WITH ASME Y14.100-2004.
 2. INTERPRET DIMENSIONS AND TOLERANCES PER ASME Y14.5M-1994.
 3. DIMENSIONS ARE IN INCHES.
 4. FLAT PART TO BE MANUFACTURED FROM PRO/ENGINEER DATA FILE SE122-408-FLAT.PRT. DIMENSIONS SHOWN ARE FOR PART VERIFICATION ONLY.
 5. MAGNETIC PERMEABILITY NOT TO EXCEED 1.02 AS TESTED BY A SEVERN INDICATOR. AVAILABLE FROM: SEVERN ENGINEERING AUBURN, ALABAMA 36830 WWW.SEVERNGINEERING.COM

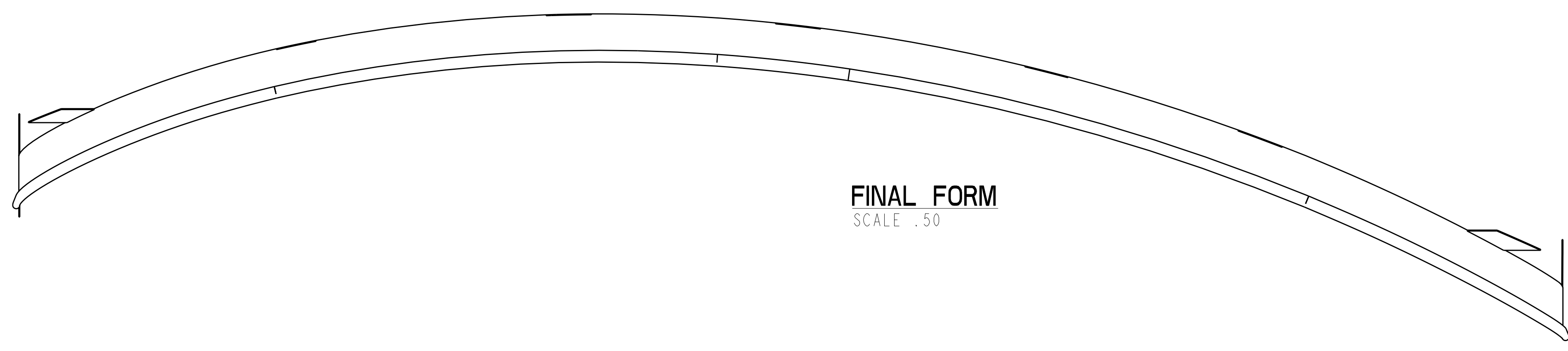

FINAL FORM
SCALE .50

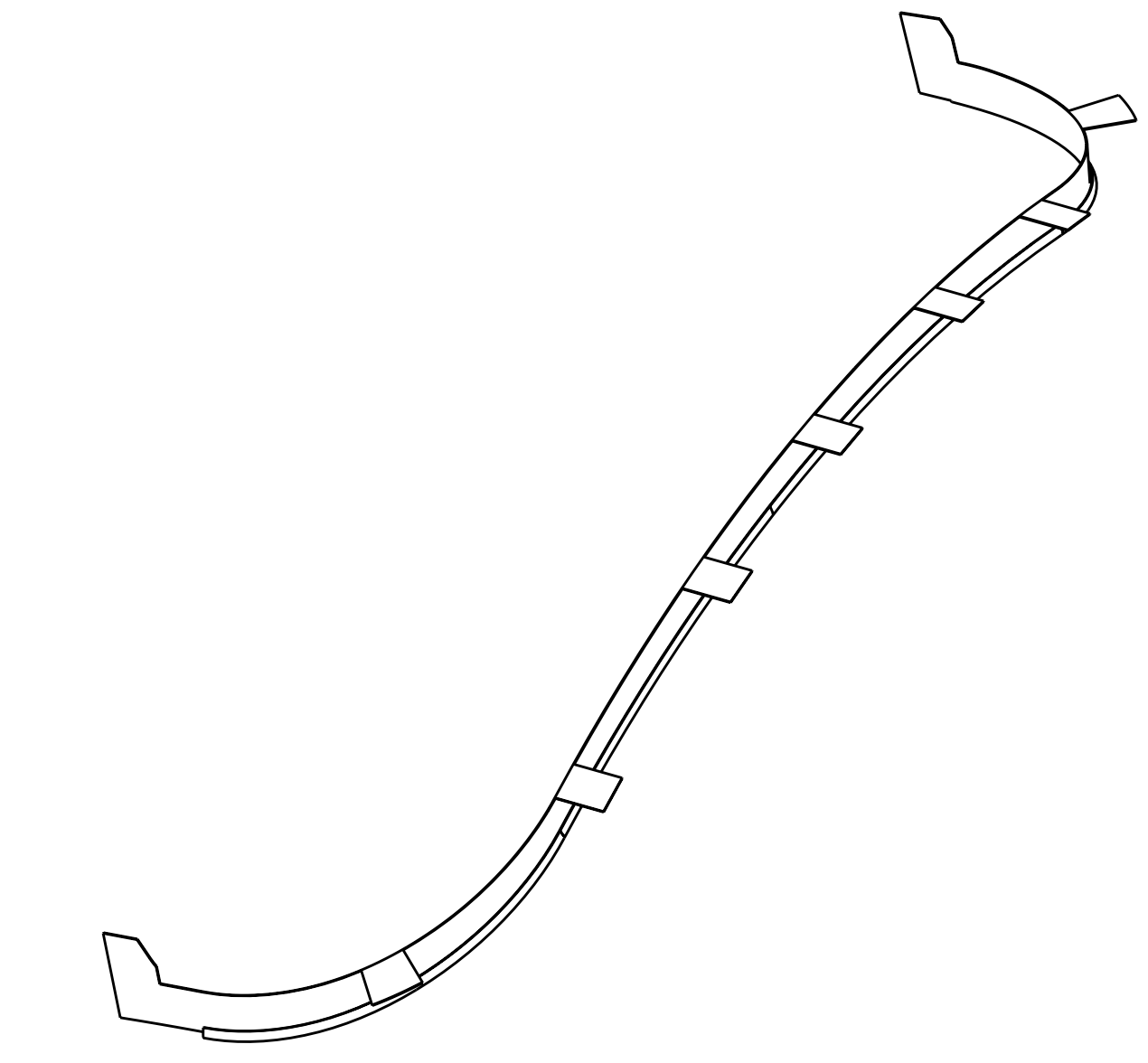
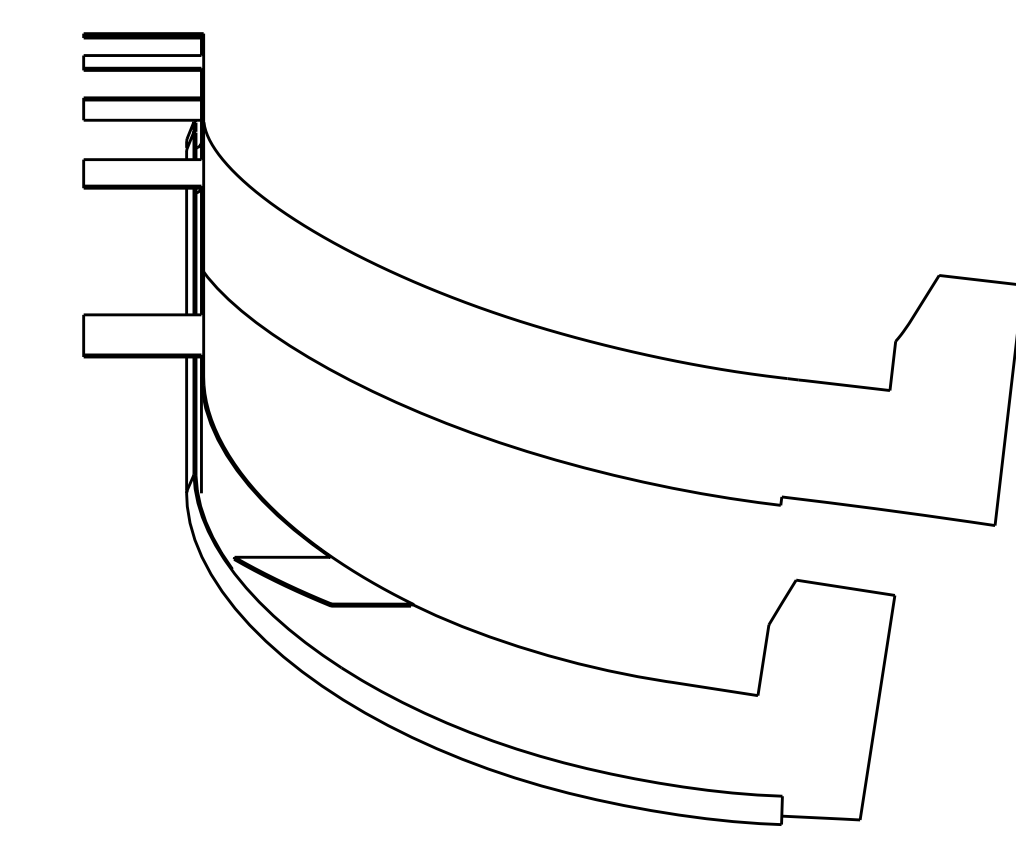

ISOMETRIC VIEW
SCALE .25

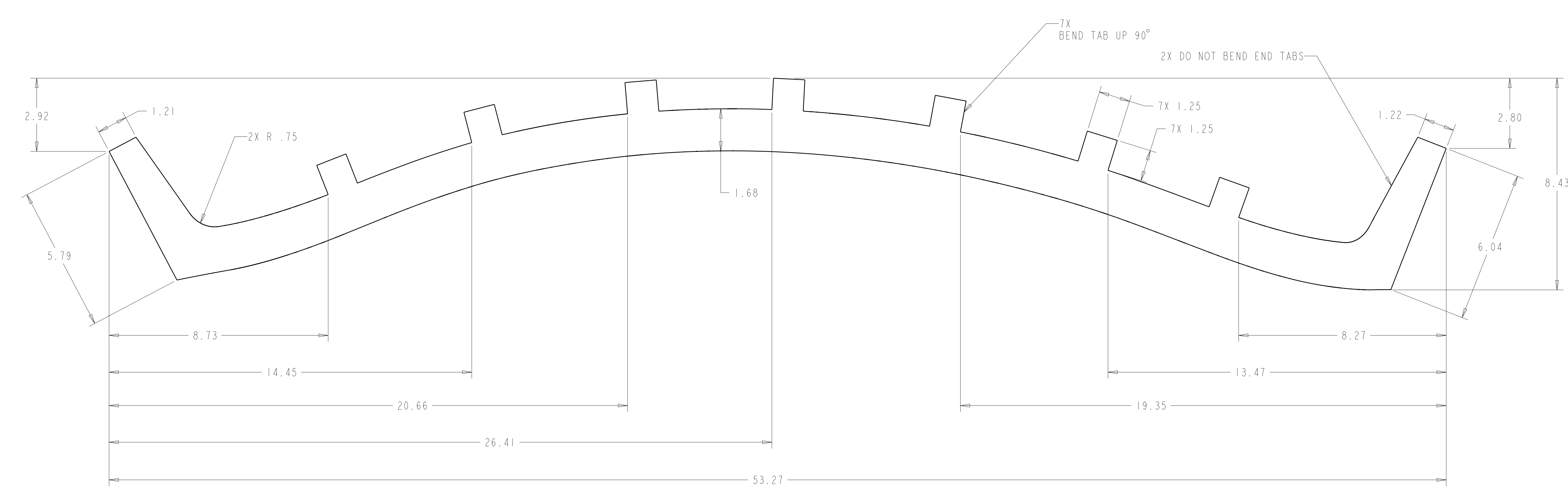

FLAT PATTERN AND BEND LINES [4]
SCALE .50



RELEASED FOR FABRICATION / INSTALLATION
PPPL Drafting:

1:1 SCALE
AT FULL SIZE

NOTE: BLANKET TOL FOR ALL 2 PLACE DECIMALS = ±.03

REV	DESCRIPTION	BY	DATE	CHK	DEPT	DATE	PE	REQ	DATE	ORNL	DOE	DATE
0	ORIGINAL ISSUE	MTR	01/07	SP		01/07						

AR	CAGE CODE	PART OR IDENTIFYING NO	NOMENCLATURE OR DESCRIPTION	MATERIAL	SPECIFICATION	FIND NO
4	AR	-1	PORT 4 SEAL CUFF RIGHT SIDE	24 GA (.02 THK) 316L SST	ASTM A240	1

DES	DRW	CHK	SECT	DEPT	PE	CR	PJ	REQ	FINISH	PPPL DRFT	VERSION NO.	PLANT	BLDG	FL	SHT	OF	TYPE	CLASS
P GORANSON	MT BROWN	S PARSON							.125 UNLESS OTHERWISE SPECIFIED	J SIEGEL	6	ORNL	5700	3	1	1	S	U

1 PORT 4 SEAL CUFF RIGHT SIDE [4]
SCALE .50

NO REPRESENTATION OR WARRANTY, EXPRESSED OR IMPLIED, IS MADE AS TO THE ACCURACY, COMPLETENESS OR USEFULNESS OF THE INFORMATION OR STATEMENTS CONTAINED IN THESE DRAWINGS, OR THAT THE USE OR DISCLOSURE OF ANY INFORMATION, APPARATUS, METHOD OR PROCESS DISCLOSED IN THESE DRAWINGS MAY NOT INFRINGE PRIVATE RIGHTS OF OTHERS. NO LIABILITY IS ASSUMED WITH RESPECT TO THE USE OF, OR FOR DAMAGES RESULTING FROM THE USE OF, ANY INFORMATION, APPARATUS, METHOD OR PROCESS DISCLOSED IN THESE DRAWINGS. DRAWINGS MADE AVAILABLE FOR INFORMATION TO BIDDER ARE NOT TO BE USED FOR OTHER PURPOSES, AND ARE TO BE RETURNED UPON REQUEST OF THE FORWARDING CONTRACTOR.

P THIS DRAWING PRODUCED ON PRO-ENGINEER

Oak Ridge National Laboratory managed for the DEPARTMENT OF ENERGY under U.S. GOVERNMENT contract DE-AC05-00OR22725 UT-BATTELLE, LLC. Oak Ridge, Tennessee

UT-BATTELLE

NATIONAL COMPACT STELLARATOR EXPERIMENT

PORT 4 SEAL CUFF RIGHT SIDE

RELEASE LEVEL: Fabrication

SE122-408

REV 0