

NOTES
 1. INTERPRET DIMENSIONS AND TOLERANCES PER ANSI Y14.5M.
 2. DIMENSIONS ARE IN INCHES

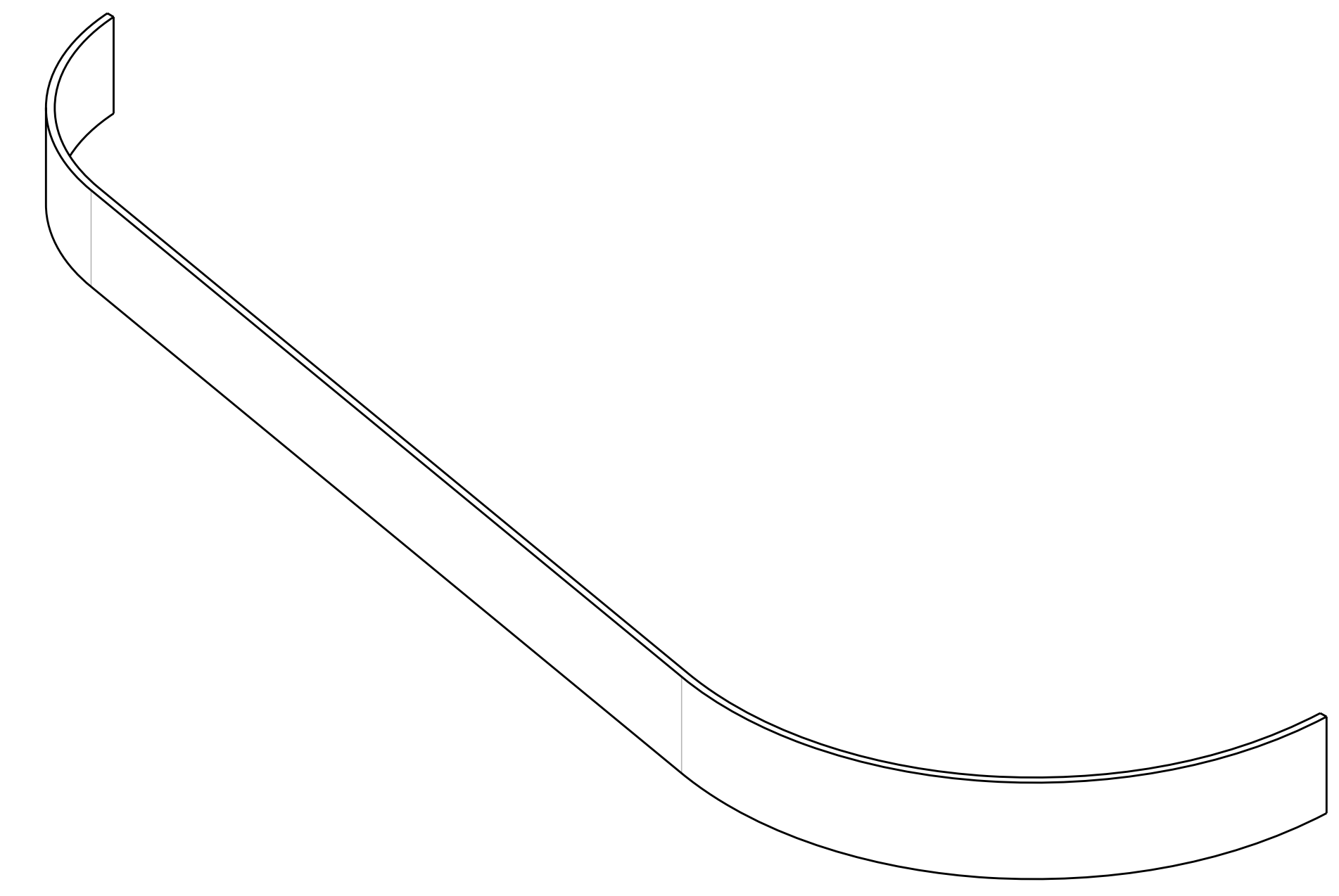

ISOMETRIC VIEW
SCALE 0.500

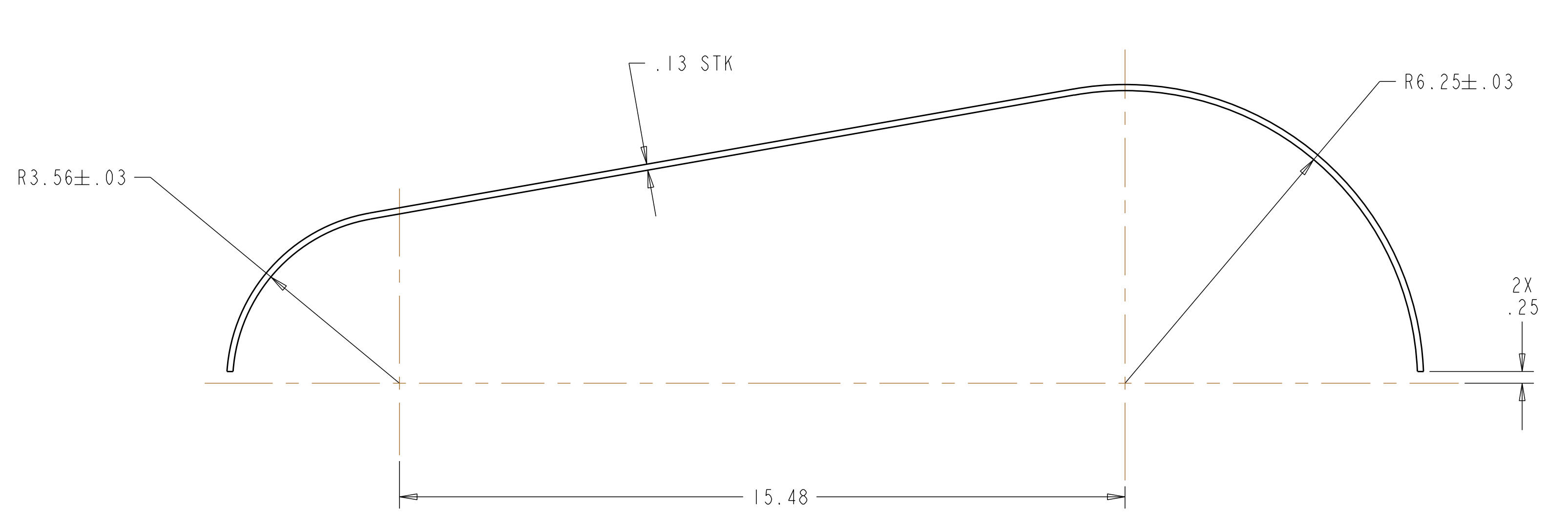
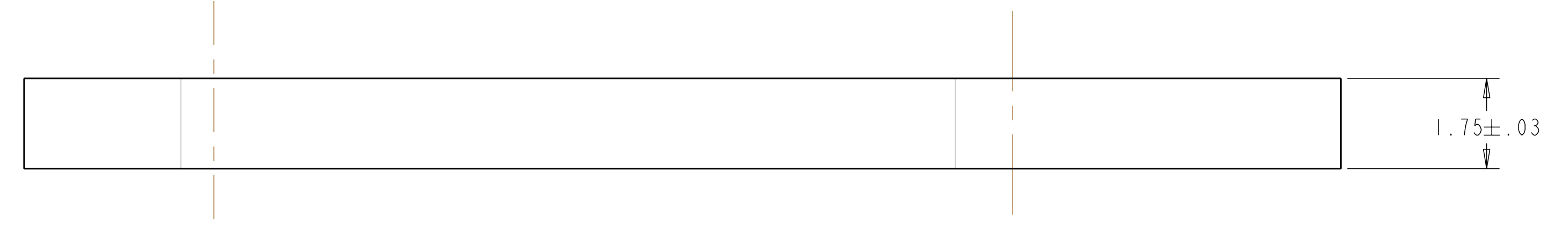

① SCALE: 2.00

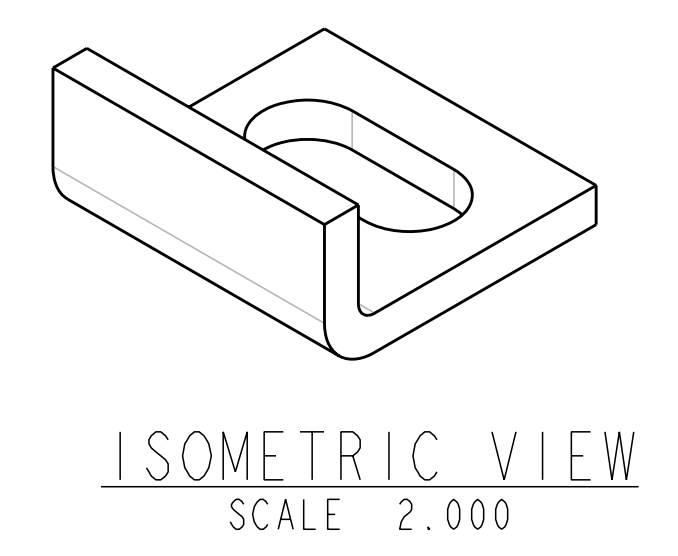
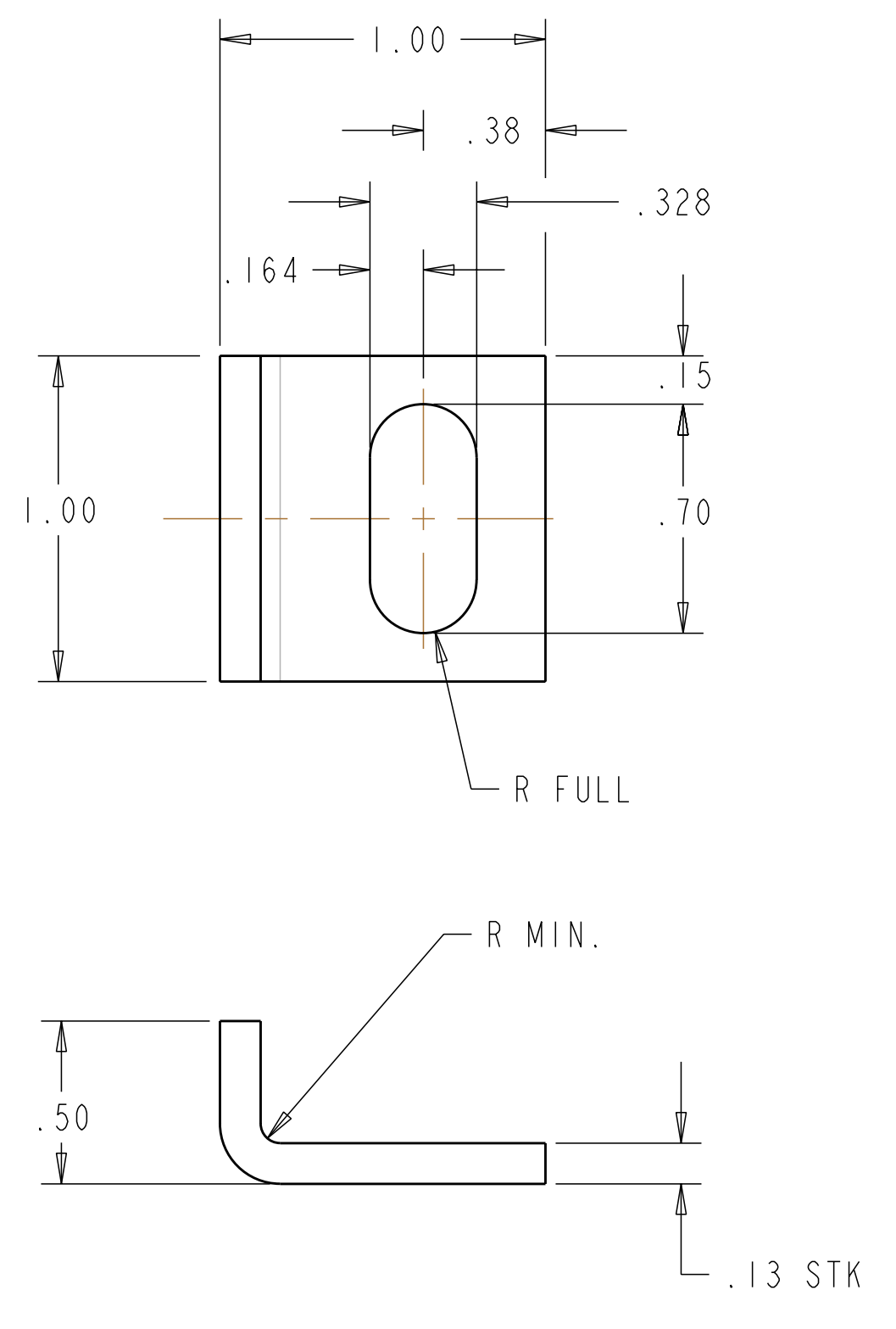

ISOMETRIC VIEW
SCALE 2.000

② SCALE: 2.00

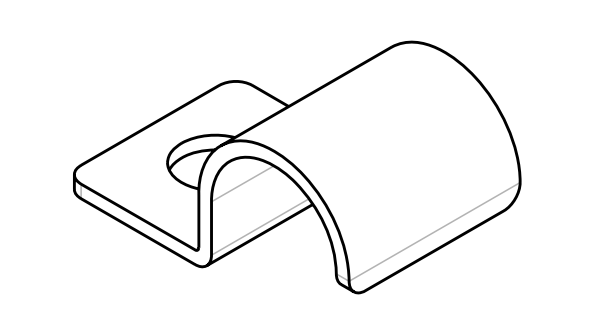
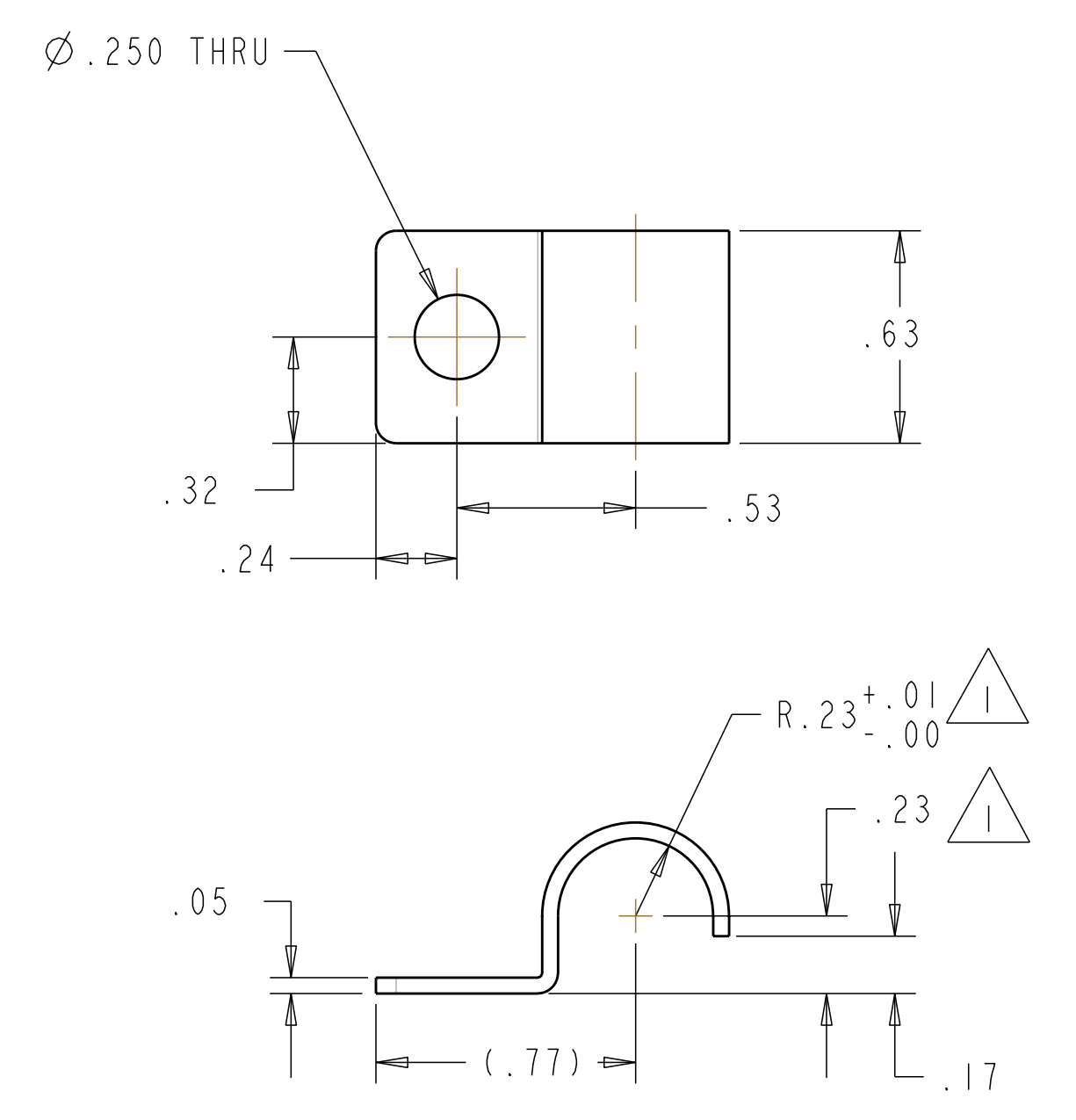

ISOMETRIC VIEW
SCALE 2.000

③ SCALE: 2.00

RELEASED FOR FABRICATION / INSTALLATION
 PPPL Drafting:

REV	DESCRIPTION	BY	DATE	CHK	DEPT	DATE	PE	REQ	DATE	ORNL	DOE	DATE
2	ECN NO. 5184 SEI21-008 WAS SEI23-049	GM	10/06									
1	PER ECN NO. 5038	MTB	11/8/05	MJC		12/05						
0	ORIGINAL ISSUE											

REV	DESCRIPTION	BY	DATE	CHK	DEPT	DATE	PE	REQ	DATE	ORNL	DOE	DATE
2	ECN NO. 5184 SEI21-008 WAS SEI23-049	GM	10/06									
1	PER ECN NO. 5038	MTB	11/8/05	MJC		12/05						
0	ORIGINAL ISSUE											

CAGE CODE	PART OR IDENTIFYING NO	NOMENCLATURE OR DESCRIPTION	MATERIAL	SPECIFICATION	FIND NO
AR AR	-3	TUBE STRAP	PHOSPHOR BRONZE C52100	ASTM B139	3
AR AR	-2	MOUNTING BRACKET	316 SST ANNEALED	ASTM A240	2
AR AR	-1	MOUNTING SUPPORT	316 SST ANNEALED	ASTM A240	1

SEI23-170	SEI23-171	SEI21-008	NEXT ASSEMBLY		PARTS LIST	

②

NO REPRESENTATION OR WARRANTY, EXPRESSED OR IMPLIED, IS MADE AS TO THE ACCURACY, COMPLETENESS OR USEFULNESS OF THE INFORMATION OR STATEMENTS CONTAINED IN THESE DRAWINGS, OR THAT THE USE OR DISCLOSURE OF ANY INFORMATION, APPARATUS, METHOD OR PROCESS DISCLOSED IN THESE DRAWINGS MAY NOT INFRINGE PRIVATE RIGHTS OF OTHERS. NO LIABILITY IS ASSUMED WITH RESPECT TO THE USE OF, OR FOR DAMAGES RESULTING FROM THE USE OF, ANY INFORMATION, APPARATUS, METHOD OR PROCESS DISCLOSED IN THESE DRAWINGS. DRAWINGS MADE AVAILABLE FOR INFORMATION TO BIDDER ARE NOT TO BE USED FOR OTHER PURPOSES, AND ARE TO BE RETURNED UPON REQUEST OF THE FORWARDING CONTRACTOR.

P THIS DRAWING PRODUCED ON PRO-ENGINEER

REVISION OR ISSUE PURPOSE	REVISION APPROVAL

SCALE NOTED
 TOLERANCES UNLESS OTHERWISE SPECIFIED:
 FRACTIONS :
 XX DECIMALS ±.03
 XXX DECIMALS ±.005
 ANGLES ±0°15'
 BREAK SHARP EDGES .06 MAX

DES. P.L. GORANSON 04/28/05
 DRW. G.H. JONES 04/28/05
 CHK. S. PARSON 05/05
 SECT. :
 DEPT. :
 PE :
 CR :
 PJ :
 RED :
 PPPL DRFT J. SIEGEL 10/05

UT-BATTELLE
 Oak Ridge National Laboratory managed for the DEPARTMENT OF ENERGY under U.S. GOVERNMENT contract DE-AC05-00OR22725 UT-BATTELLE, LLC. Oak Ridge, Tennessee
 PROJECT NAME: NATIONAL COMPACT STELLARATOR EXPERIMENT
 VACUUM VESSEL HEATING/COOLING MISCELLANEOUS DETAILS

VERSION NO. 1 PLANT X10 BLDG 5700 FL 3 SHT 1 OF 1 TYPE I CLASS U
 RELEASE LEVEL Fabrication SEI23-172 REV 2