

SECTION B-B
SCALE: 1.00

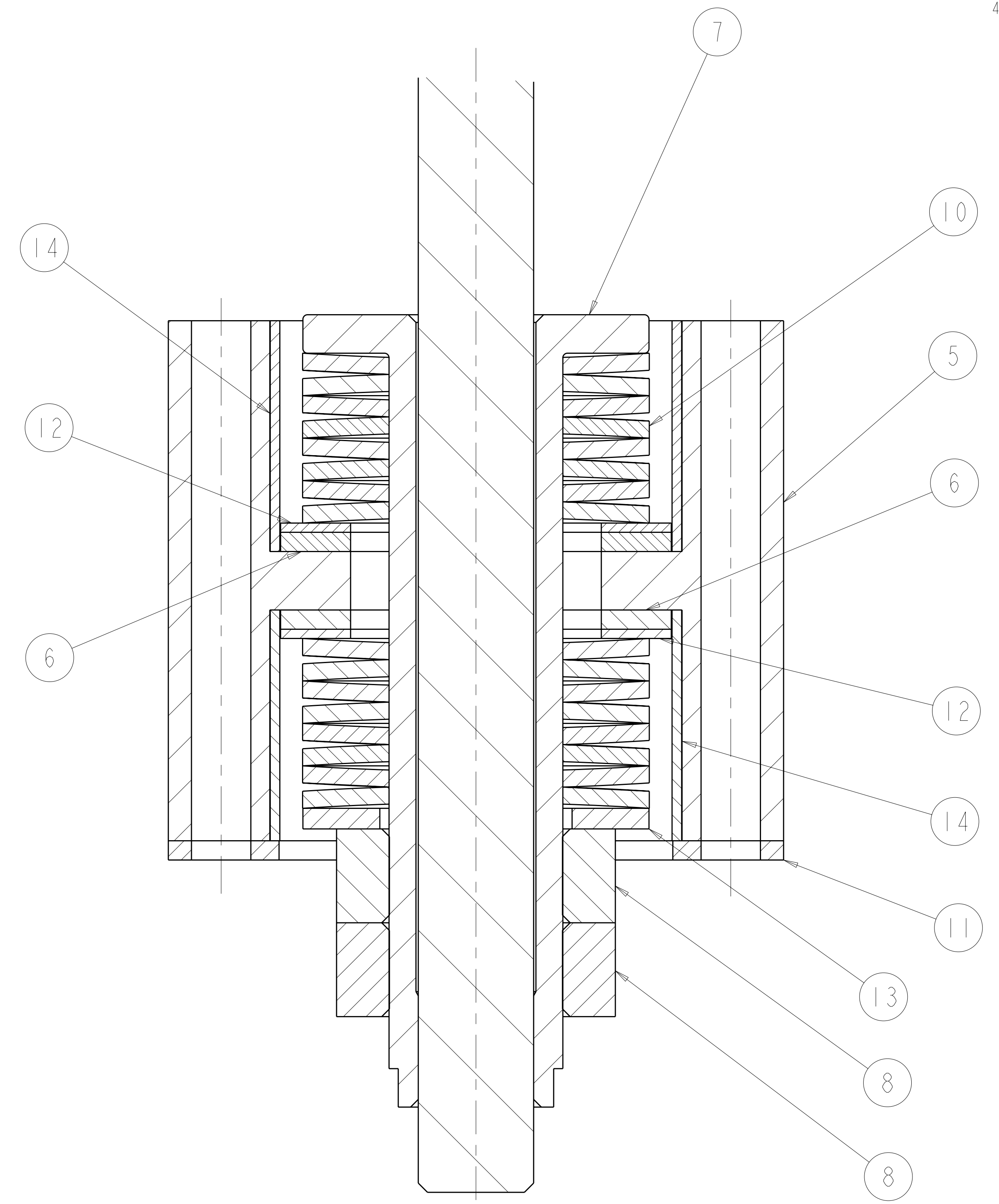

DETAIL Y
SCALE: 2.00

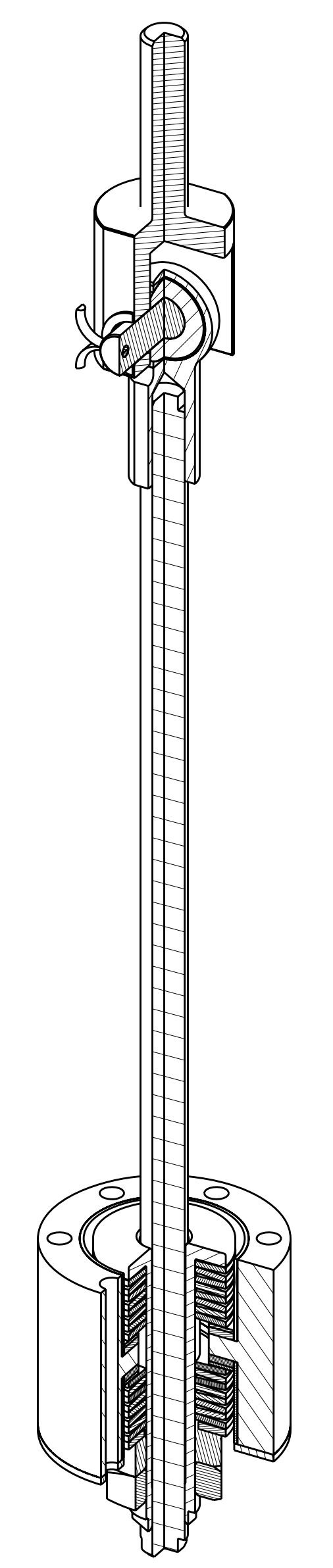

ISOMETRIC VIEW
SCALE: .50

- NOTES:
1. INTERPRET DIMENSIONS AND TOLERANCES PER ANSI Y14.5M
 2. DIMENSIONS ARE IN INCHES
 3. DIMENSIONS APPLY AT TEMPERATURE OF 20-30°C (68-86°F)
 4. APPROXIMATE TOTAL WEIGHT = 13 lbs.

REV	DESCRIPTION	BY	DATE	CHK	DEPT	DATE	PE	REQ	DATE	ORNL	DOE	DATE
0	ORIGINAL ISSUE	GHJ	03/05									
1	COTTER PIN WAS HAIRPIN PER ECNH 5379	WDM	01/08									

REV	DESCRIPTION	BY	DATE	CHK	DEPT	DATE	PE	REQ	DATE	ORNL	DOE	DATE
0	ORIGINAL ISSUE	GHJ	03/05									
1	COTTER PIN WAS HAIRPIN PER ECNH 5379	WDM	01/08									

REV	DESCRIPTION	BY	DATE	CHK	DEPT	DATE	PE	REQ	DATE	ORNL	DOE	DATE
0	ORIGINAL ISSUE	GHJ	03/05									
1	COTTER PIN WAS HAIRPIN PER ECNH 5379	WDM	01/08									

REV	DESCRIPTION	BY	DATE	CHK	DEPT	DATE	PE	REQ	DATE	ORNL	DOE	DATE
0	ORIGINAL ISSUE	GHJ	03/05									
1	COTTER PIN WAS HAIRPIN PER ECNH 5379	WDM	01/08									

CAGE CODE	PART OR IDENTIFYING NO	NOMENCLATURE OR DESCRIPTION	MATERIAL	SPECIFICATION	FIND NO
16	#98355A240	COTTER PIN 3/16 X 1-1/2 316 SST	MCMaster-CARR SUPPLY CO. P.O. BOX 549670 LOS ANGELES, CA. 90054-0960		16
15	∅ .75	WASHER, FLAT	300 SERIES SST	ANSI B18.22.1	15
14	SE124-064	VERTICAL LOWER SUPPORT INSULATING SLEEVE			14
13	SE124-063	VERTICAL LOWER SUPPORT PLAIN WASHER			13
12	SE124-058	VERTICAL LOWER SUPPORT HARDENED WASHER			12
11	SE124-057	VERTICAL LOWER SUPPORT RETAINER WASHER			11
10	SE124-056	VERTICAL LOWER SUPPORT WASHER, BELLEVILLE			10
9	SE124-055	VERTICAL SUPPORT CLEVIS			9
8	SE124-049	VERTICAL LOWER SUPPORT JAM NUT, HEX			8
7	SE124-048	VERTICAL LOWER SUPPORT ADJUSTER			7
6	SE124-039	VERTICAL LOWER SUPPORT INSULATING WASHER			6
5	SE124-035	VERTICAL LOWER SUPPORT INSERT			5
4	SE124-021	VERTICAL LOWER SUPPORT ROD			4
3	SE124-014	VERTICAL SUPPORT ROD END, FEMALE			3
2	SE124-013	VERTICAL SUPPORT CLEVIS PIN			2
1	-1	VERTICAL LOWER SUPPORT ASSEMBLY			1

RELEASED FOR FABRICATION / INSTALLATION
PPPL Drafting

NO REPRESENTATION OR WARRANTY, EXPRESSED OR IMPLIED, IS MADE AS TO THE ACCURACY, COMPLETENESS OR USEFULNESS OF THE INFORMATION OR STATEMENTS CONTAINED IN THESE DRAWINGS, OR THAT THE USE OR DISCLOSURE OF ANY INFORMATION, APPARATUS, METHOD OR PROCESS DISCLOSED IN THESE DRAWINGS MAY NOT INFRINGE PRIVATE RIGHTS OF OTHERS. NO LIABILITY IS ASSUMED WITH RESPECT TO THE USE OF, OR FOR DAMAGES RESULTING FROM THE USE OF, ANY INFORMATION, APPARATUS, METHOD OR PROCESS DISCLOSED IN THESE DRAWINGS. DRAWINGS MADE AVAILABLE FOR INFORMATION TO BIDDER ARE NOT TO BE USED FOR OTHER PURPOSES, AND ARE TO BE RETURNED UPON REQUEST OF THE FORWARDING CONTRACTOR.

P THIS DRAWING PRODUCED ON PRO-ENGINEER

SCALE NOTED: UNLESS OTHERWISE SPECIFIED: FRACTIONS XX DECIMALS ±.01 XXX DECIMALS ±.005 ANGLES ±0°15' BREAK SHARP EDGES OR MAX FINISH .125 UNLESS OTHERWISE SPECIFIED

DES: PAUL MILLER 08-17-04
 DRW: PAUL MILLER 08-17-04
 CHK: J.M. RAY 04-07-05

UT-BATTELLE
 Oak Ridge National Laboratory managed for the DEPARTMENT OF ENERGY under U.S. GOVERNMENT CONTRACT DE-AC05-00OR22725 UT-BATTELLE, LLC. Oak Ridge, Tennessee

NATIONAL COMPACT STELLARATOR EXPERIMENT

VERTICAL LOWER SUPPORT ASSEMBLY

VERSION NO. 1 PLANT X10 BLDG 5700 FL 3 SHT 1 OF 1 TYPE I CLASS A

RELEASE LEVEL SE124-054