

- NOTES:
1. INTERPRET DIMENSIONS AND TOLERANCES PER ANSI Y14.5M
  2. DIMENSIONS ARE IN INCHES
  3. DIMENSIONS APPLY AT TEMPERATURE OF 20-30°C (68-86°F)
  4. DRAWING DEPICTS FINAL MACHINED STATE OF PART DEFINED BY PRO/ENGINEER FILE SE124-082.PRT
  5. APPROXIMATE WEIGHT= 0.11 LBS

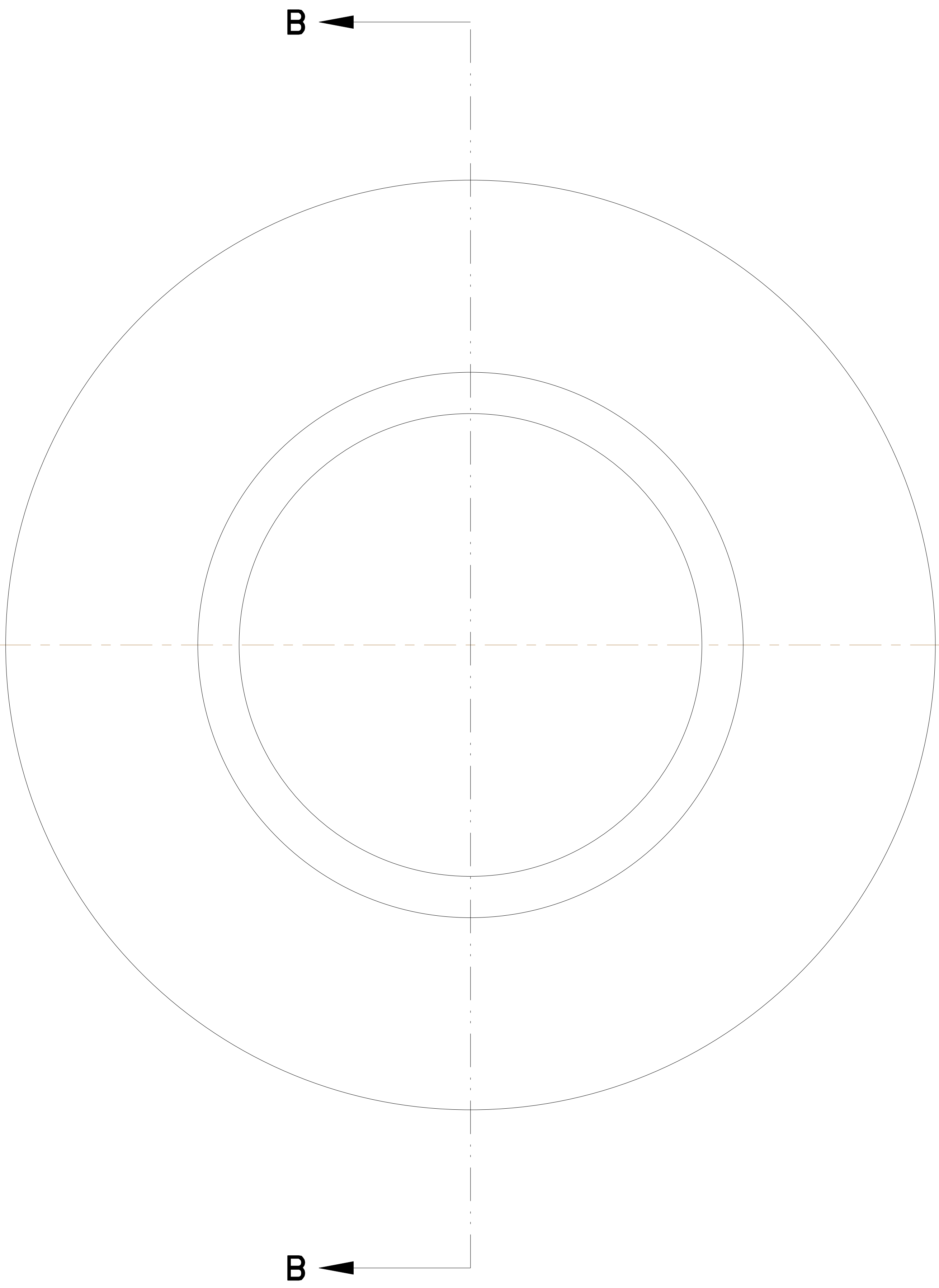

1

SCALE 6.00

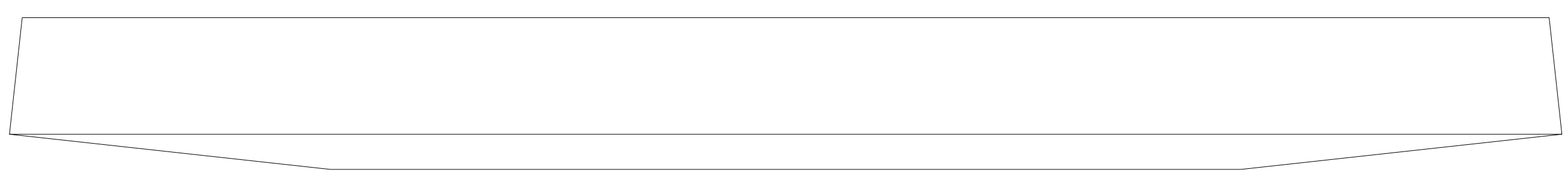
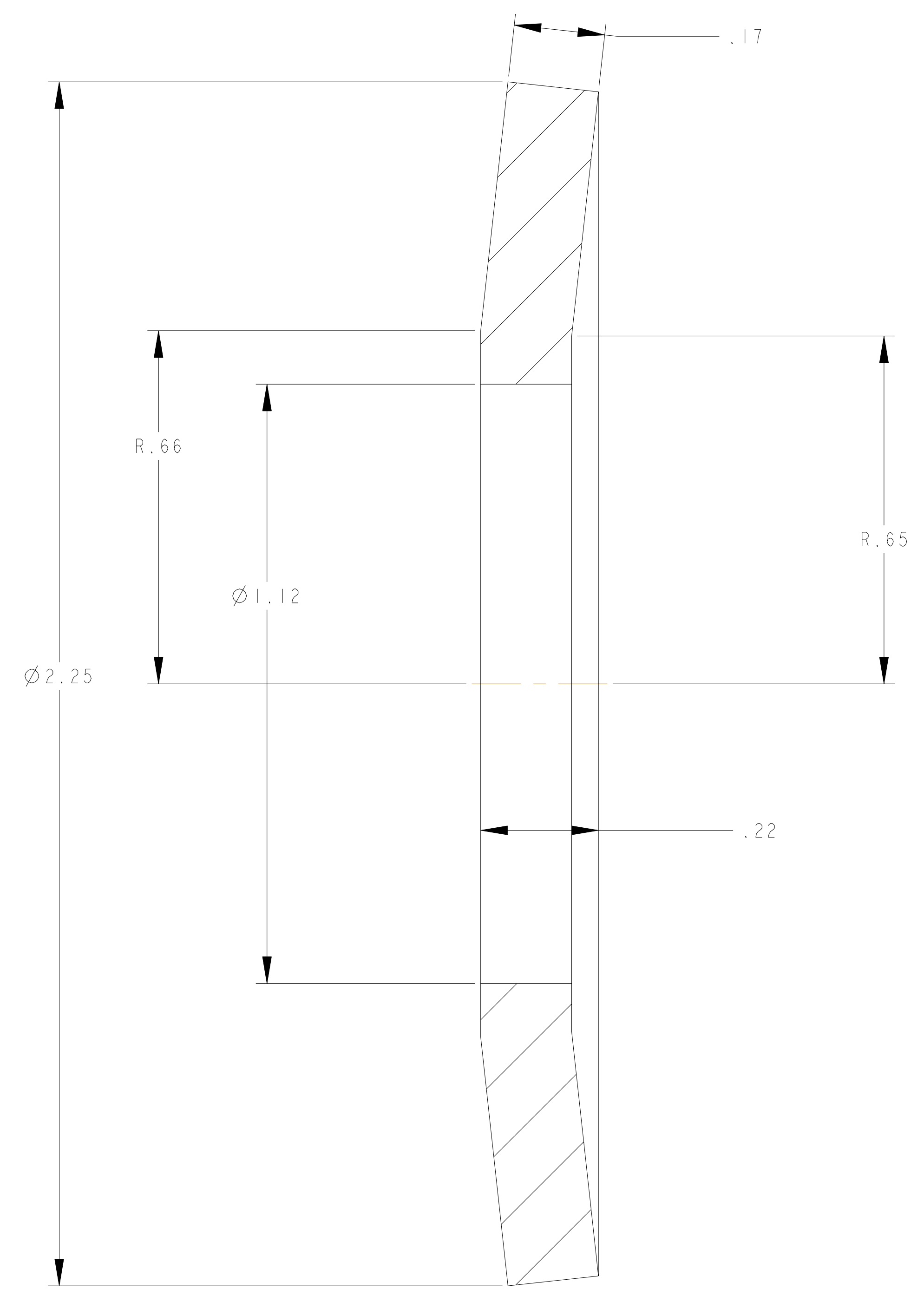

SECTION B-B

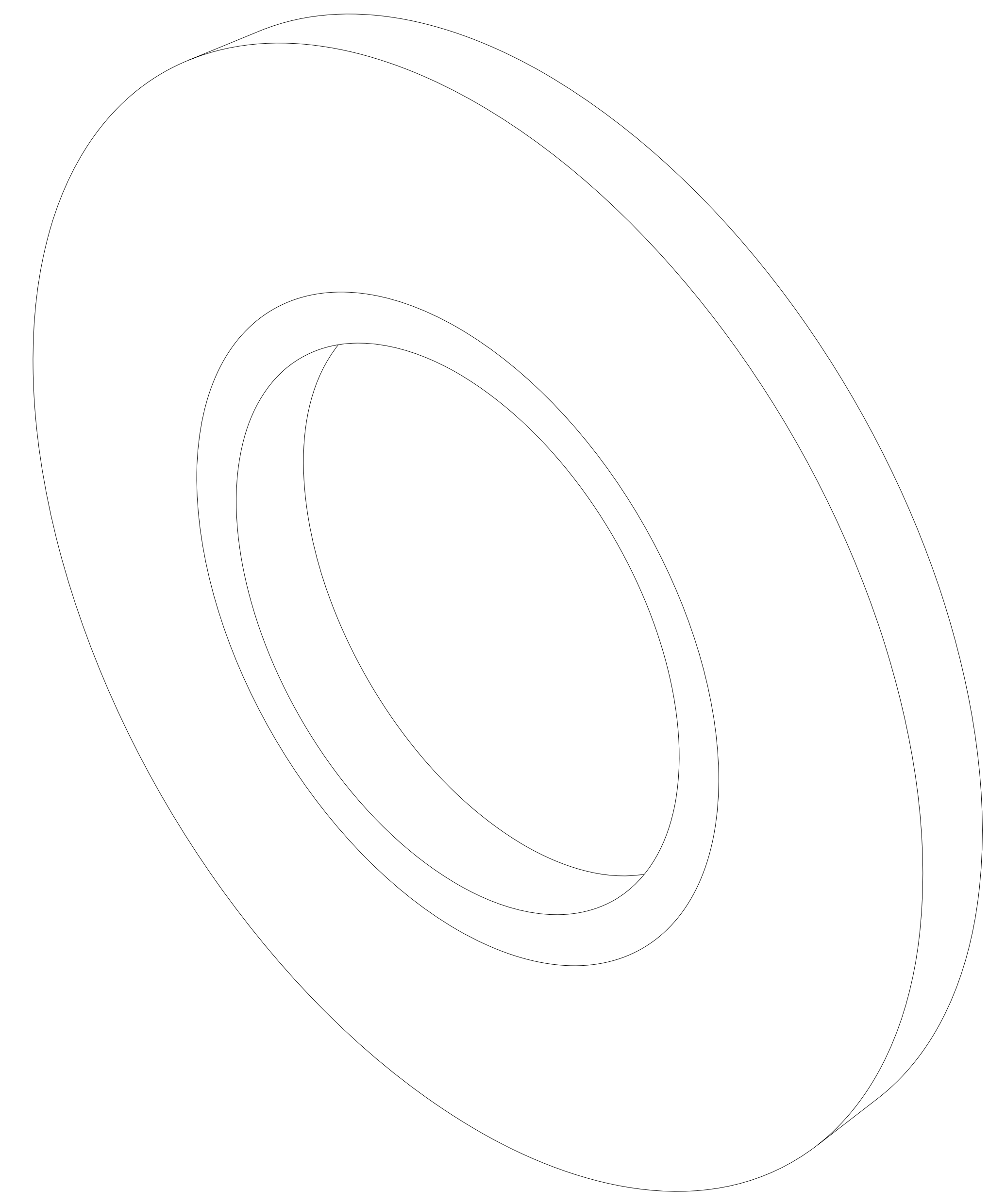

SCALE 6.00

next assy	AR	-1	2.25 OD X 1.12 ID DISC SPRING FLAT LOAD = 8.753 LBS	INCONEL 718	KEY BELLEVILLE SIMILAR TO TYPE K2250-L-168	I
SE124-051	CAGE CODE	PART OR IDENTIFYING NO	NOMENCLATURE OR DESCRIPTION	MATERIAL	SPECIFICATION	FIND NO
		NEXT ASSEMBLY		PARTS LIST		

RELEASED FOR FABRICATION / INSTALLATION  
 PPPL Drafting

NO REPRESENTATION OR WARRANTY, EXPRESSED OR IMPLIED, IS MADE AS TO THE ACCURACY, COMPLETENESS OR USEFULNESS OF THE INFORMATION OR STATEMENTS CONTAINED IN THESE DRAWINGS, OR THAT THE USE OR DISCLOSURE OF ANY INFORMATION, APPARATUS, METHOD OR PROCESS DISCLOSED IN THESE DRAWINGS MAY NOT INFRINGE PRIVATE RIGHTS OF OTHERS. NO LIABILITY IS ASSUMED WITH RESPECT TO THE USE OF, OR FOR DAMAGES RESULTING FROM THE USE OF, ANY INFORMATION, APPARATUS, METHOD OR PROCESS DISCLOSED IN THESE DRAWINGS. DRAWINGS MADE AVAILABLE FOR INFORMATION TO BIDDER ARE NOT TO BE USED FOR OTHER PURPOSES, AND ARE TO BE RETURNED UPON REQUEST OF THE FORWARDING CONTRACTOR.

**P** THIS DRAWING PRODUCED ON PRO-ENGINEER

0	INITIAL RELEASE	GLL	8-06	MJC	DEW															
REV	DESCRIPTION	BY	DATE	CHK	DEPT	DATE	PE	REQ	DATE	ORNL	DOE	DATE								
	REVISION OR ISSUE PURPOSE																			

SCALE	NOTED	DES	P GORANSON	07-18-06
		DRW	GARY LOVETT	07-18-06
		CHK	R MOON	0-06
		SECT		
		DEPT		
		PE	D WILLIAMSON	0-06
		CR		
		PJ		
		REQ		
		PPPL	DRFT J SIEGLE	0-06

UT-BATTELLE		Oak Ridge National Laboratory managed for the DEPARTMENT OF ENERGY under U.S. GOVERNMENT contract DE-AC05-00OR22725 UT-BATTELLE, LLC, Oak Ridge, Tennessee	
NATIONAL COMPACT STELLARATOR EXPERIMENT			
WASHER, BELLEVILLE			
VERSION NO.	PLANT	BLDG	FL SHT OF TYPE CLASS
6	X-10	5700	3 1 1 S U
RELEASE LEVEL	Fabrication		
	SE124-082		
	REV 0		