

- NOTES:
1. INTERPRET DIMENSIONS AND TOLERANCES PER ANSI Y14.5M
 2. DIMENSIONS ARE IN INCHES
 3. DIMENSIONS APPLY AT ROOM TEMPERATURE. OPERATING TEMP 80 K
 4. GEOMETRY IS DEFINED IN PRO ENGINEER CAD MODELS/FILES
 5. DRAWING AND MODELS COMBINED DEFINE FINISHED MACHINED PART
 6. USE LOCTITE TO SECURE THREADED COMPONENTS

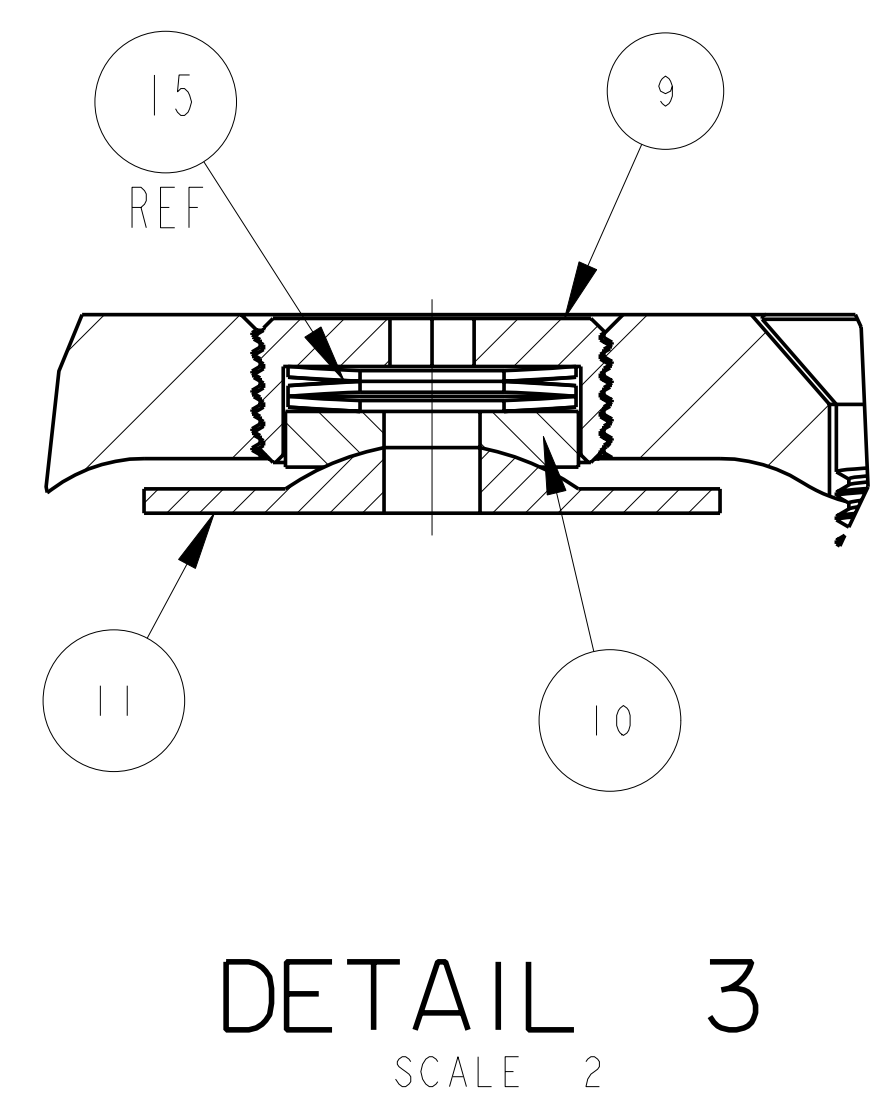
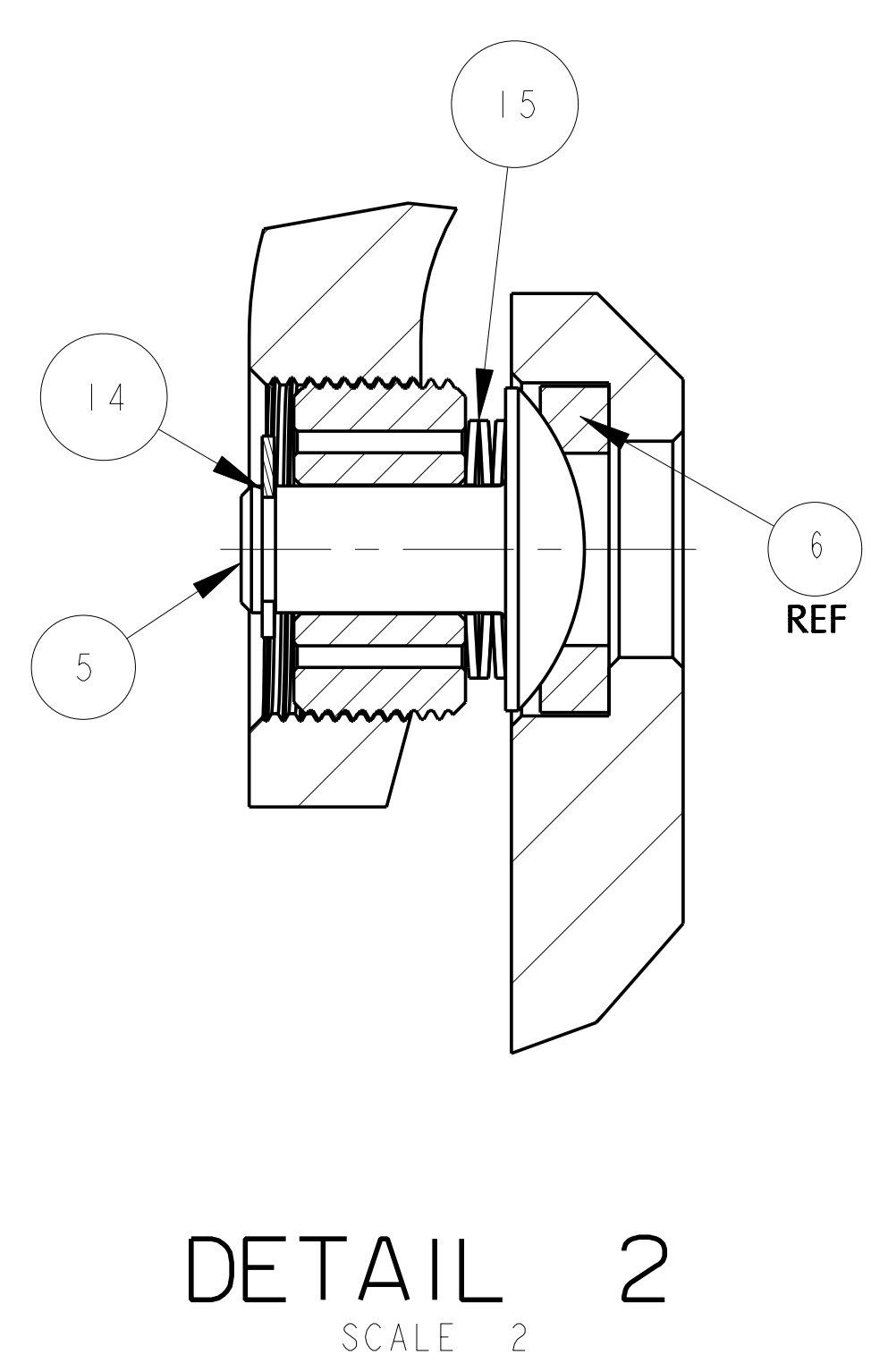
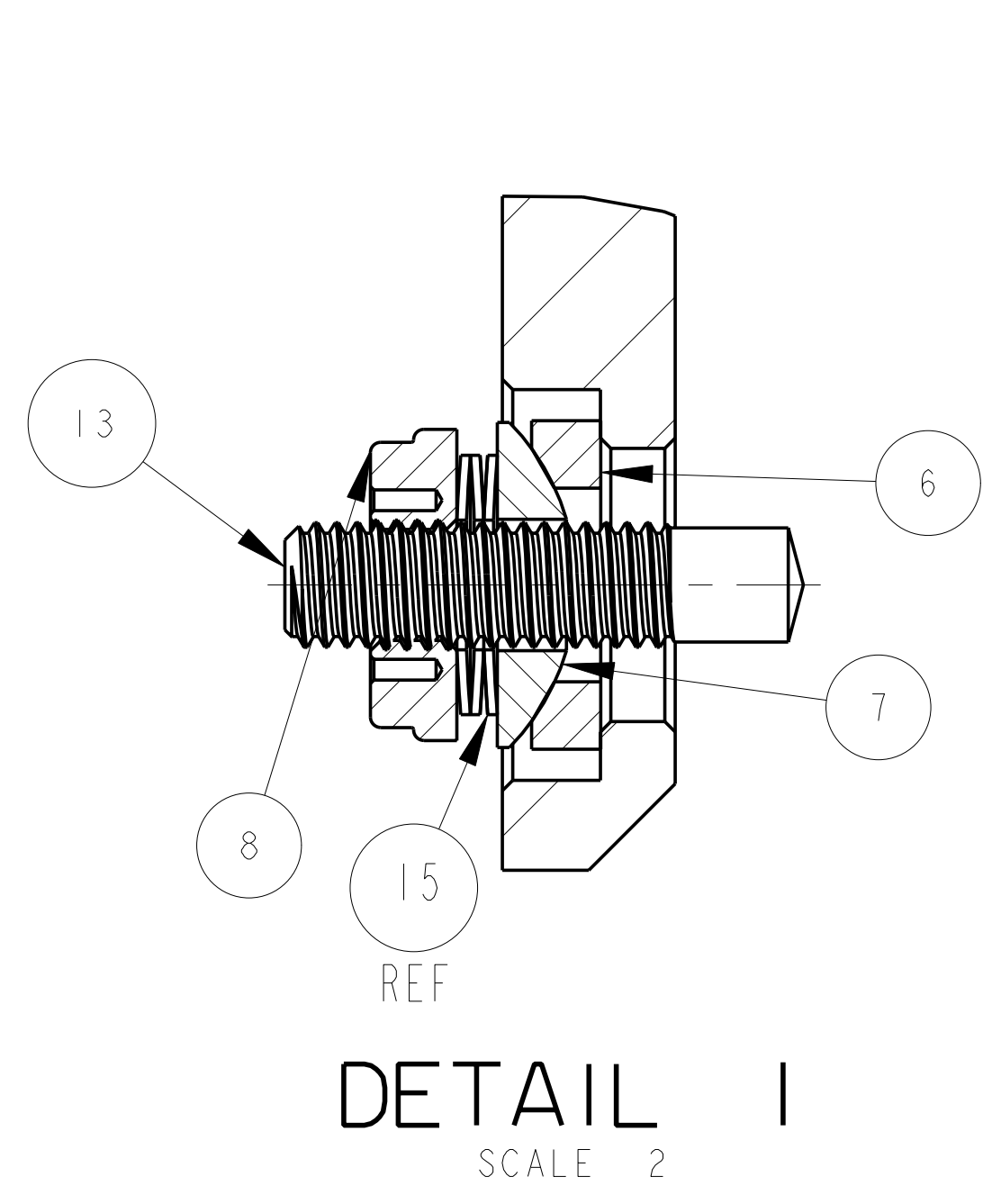
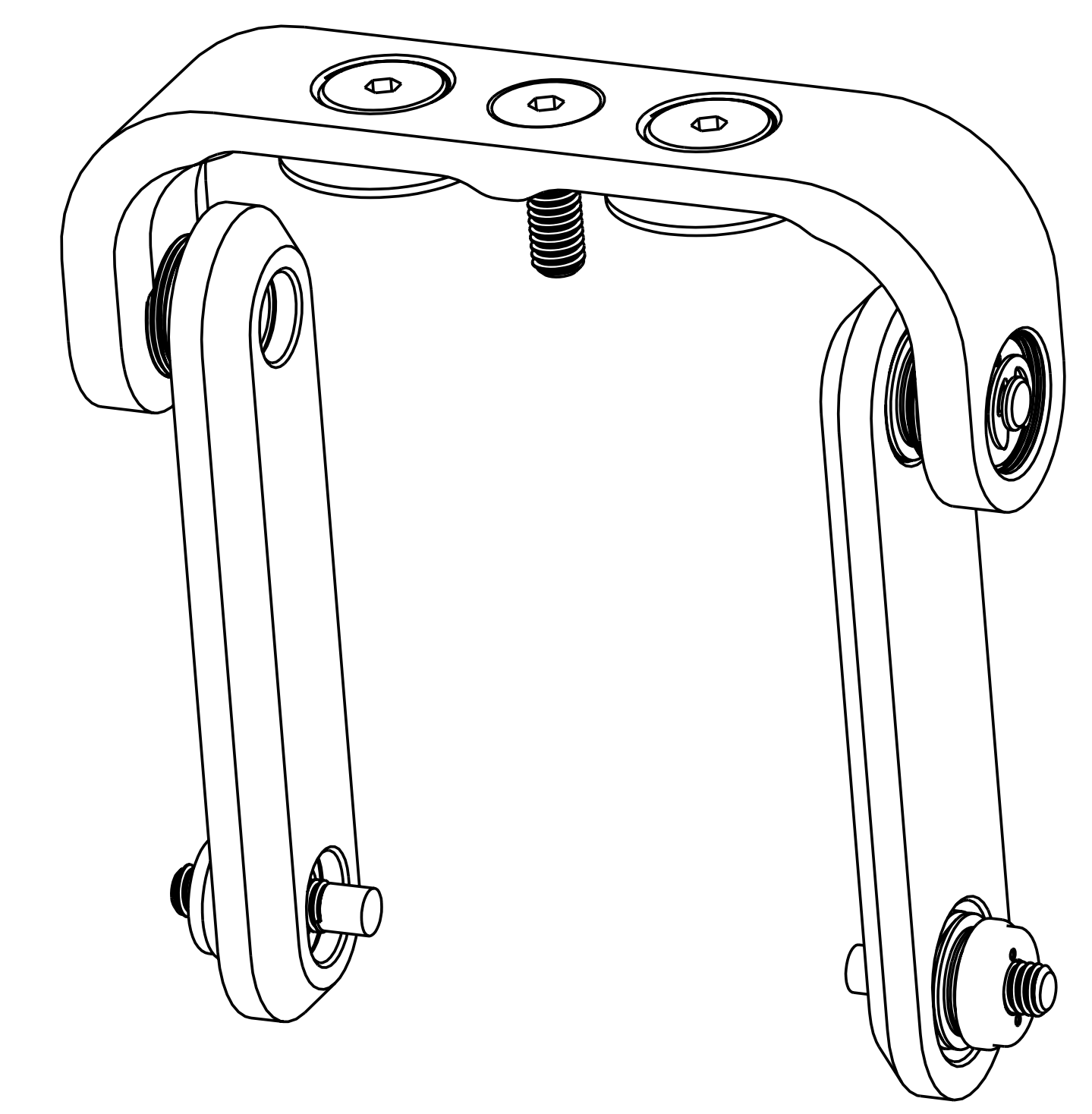
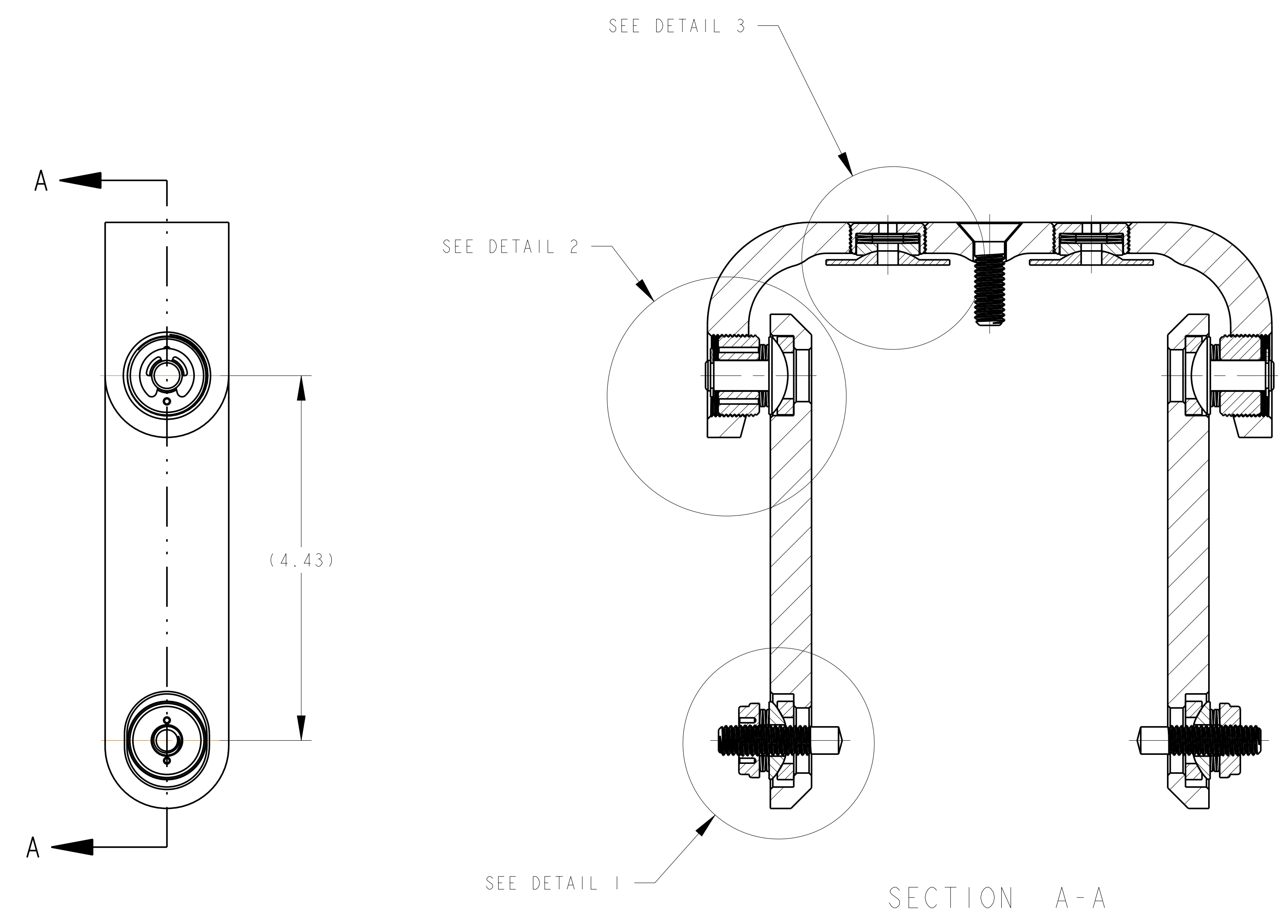
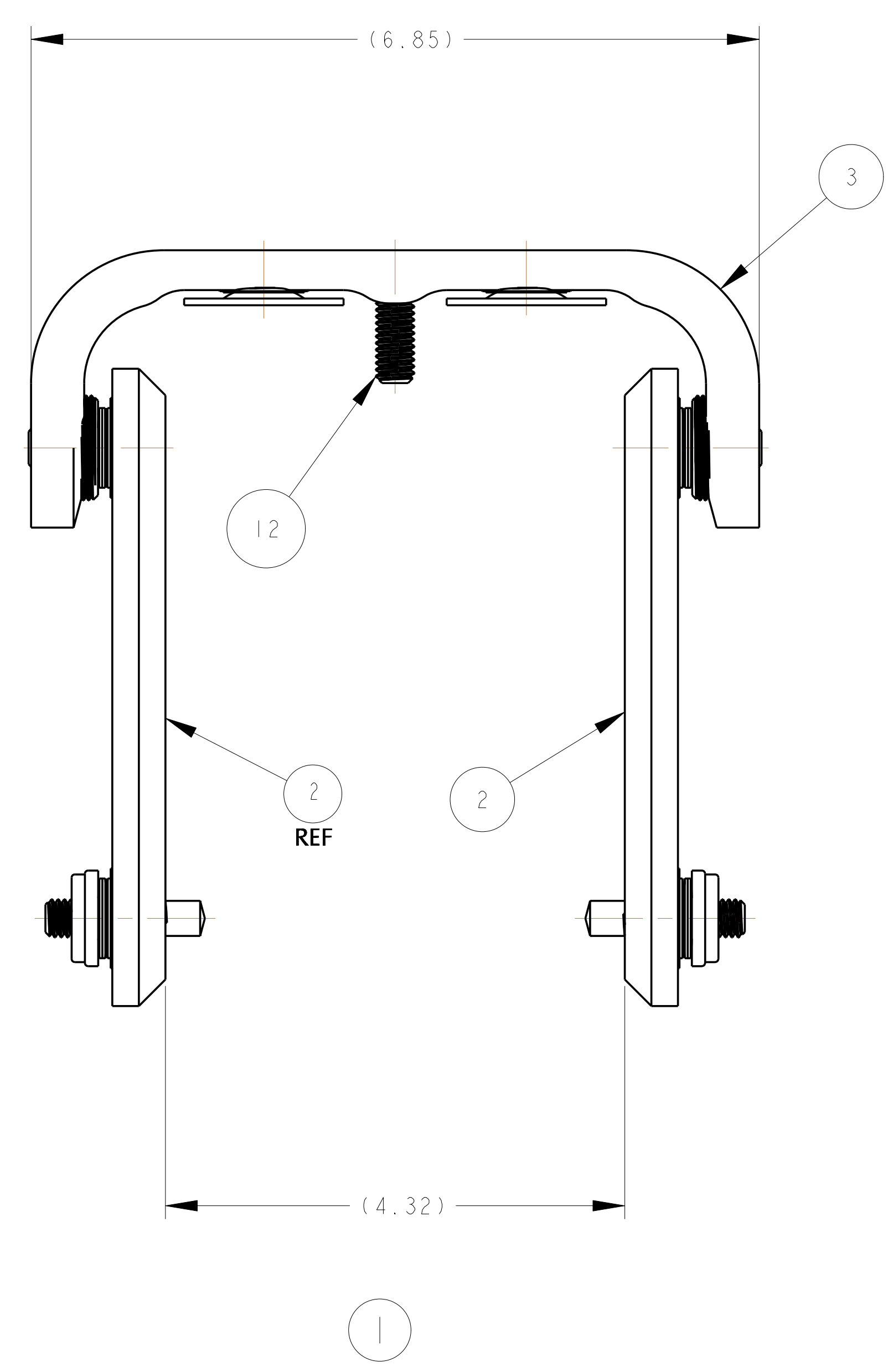
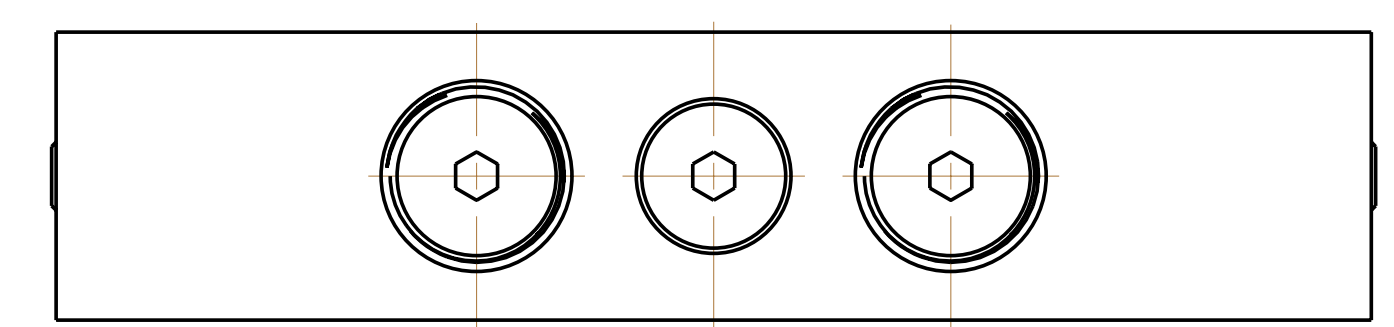

CAGE CODE	PART OR IDENTIFYING NO	NOMENCLATURE OR DESCRIPTION	MATERIAL	SPECIFICATION	FIND NO
-	15	WASHER, BELLEVILLE, 3/4 OD, 3/8 ID	BERYLLIUM COPPER	K-7600 LBS/IN	15
-	14	E-RING, EXTERNAL	BERYLLIUM COPPER	MS16633-5037	14
2	SE1405-265P	STUD, WELD, 3/8-16 UNC-2A	316L SS	--	13
1	SE1405-264P	SCREW, 3/8-16 UNC-2A X 1 1/4	316L SS AG PLATED	--	12
2	SE1405-263P	WASHER, SPHERICAL, CONVEX	316L SS	--	11
2	SE1405-262P	PISTON, SPHERICAL, CONCAVE	A286 SUPERALLOY	--	10
2	SE1405-261P	SCREW, SET, 15/16-20 UNEF-2A X 3/8	316L SS AG PLATED	--	9
2	SE1405-260P	NUT, PIN DRIVE, 3/8-16 UNC-2B	316L SS AG PLATED	--	8
2	SE1405-259P	WASHER, SPHERICAL, TYPE C	A286 SUPERALLOY	DIN 6319 MODIFIED	7
4	SE1405-257P	WASHER, SPHERICAL, TYPE D	303 SS ANNEALED	DIN 6319	6
2	SE1405-256P	RIVET, SPECIAL BUTTON HEAD	A286 SUPERALLOY	--	5
2	SE1405-255P	SCREW, SET, 1-20 UNEF-2A X 1/2	316L SS AG PLATED	--	4
1	SE1405-254P	BAR, CLAMP, HORIZONTAL	316L SS	--	3
2	SE1405-251P	BAR, CLAMP, VERTICAL	316L SS	--	2
1	SE1405-250P	CLAMP ASSEMBLY, 40 TURN	--	--	1

RELEASED FOR FABRICATION / INSTALLATION

NO REPRESENTATION OR WARRANTY, EXPRESSED OR IMPLIED, IS MADE AS TO THE ACCURACY, COMPLETENESS OR USEFULNESS OF THE INFORMATION OR STATEMENTS CONTAINED IN THESE DRAWINGS, OR THAT THE USE OR DISCLOSURE OF ANY INFORMATION, APPARATUS, METHOD OR PROCESS DISCLOSED IN THESE DRAWINGS MAY NOT INFRINGE PRIVATE RIGHTS OF OTHERS. NO LIABILITY IS ASSUMED WITH RESPECT TO THE USE OF, OR FOR DAMAGES RESULTING FROM THE USE OF, ANY INFORMATION, APPARATUS, METHOD OR PROCESS DISCLOSED IN THESE DRAWINGS. DRAWINGS MADE AVAILABLE FOR INFORMATION TO BIDDER ARE NOT TO BE USED FOR OTHER PURPOSES, AND ARE TO BE RETURNED UPON REQUEST OF THE FORWARDING CONTRACTOR.

P THIS DRAWING PRODUCED ON PRO-ENGINEER

REV	DESCRIPTION	BY	DATE	CHK	DEPT	DATE	PE	REQ	DATE	ORNL	DOE	DATE

SCALE 1	DES: PAUL MILLER 4-12-04	Oak Ridge National Laboratory managed for the DEPARTMENT OF ENERGY under U.S. GOVERNMENT contract DE-AC05-00OR22725 UT-BATTELLE, LLC. Oak Ridge, Tennessee PROJECT NAME:
TOLERANCES UNLESS OTHERWISE SPECIFIED	DRW: PAUL MILLER 4-13-04	
FRACTIONS	CHK: :	NATIONAL COMPACT STELLARATOR EXPERIMENT CLAMP ASSEMBLY, 40 TURN VERSION NO. 1 PLANT X-10 BLDG 5700 FL 3 SHT OF 1 TYPE S CLASS U RELEASE LEVEL WIP SE1405-250P REV 0
XX DECIMALS ±.01	SECT: :	
XXX DECIMALS ±.005	DEPT: :	
ANGLES ±0°15'	PE: :	
BREAK SHARP EDGES .06 MAX	CR: :	
FINISH .125 UNLESS OTHERWISE SPECIFIED	PJ: :	
	RD: :	
	PPPL DRFT: :	
	REVISION APPROVALS: :	
	DATE: :	

H G F E D C B A