

8

7

6

5

4

3

2

1

NEXT ASS'Y: FINAL ASS'Y:

- NOTES
1. DRAWING PREPARED IN ACCORDANCE WITH ASME Y14.100-2004.
 2. INTERPRET DIMENSIONS AND TOLERANCES PER ASME Y14.5M-1994.
 3. DIMENSIONS ARE IN INCHES
 4. MINIMIZE MATERIAL REMOVAL FOR ALL HOLE LOCATIONS SHOWN TO PROVIDE CLEARANCE FOR SUPERNUT. CLEARANCE IS DEFINED AS PLACING A $\varnothing 3.00"$ X 3.25" LONG CYLINDER AT EACH $\varnothing 3.00"$ SPOT FACE. THE CYLINDER SHALL NOT INTERFERE WITH THE WINDING FORM.
 6. THIS DRAWING MODIFIES THE EXISTING TYPE "A" WINDING FORM AS DEFINED IN DRAWING SE141-114.DRW.
 7. GRIND SHELL AS REQUIRED TO ALLOW INSTALLATION OF THE HEX NUT AND/OR SUPERNUT (SEE DRAWING SE140-190). ENGINEERING APPROVAL REQUIRED IF SHELL THICKNESS IS LESS THAN 1" AS A RESULT OF GRINDING.

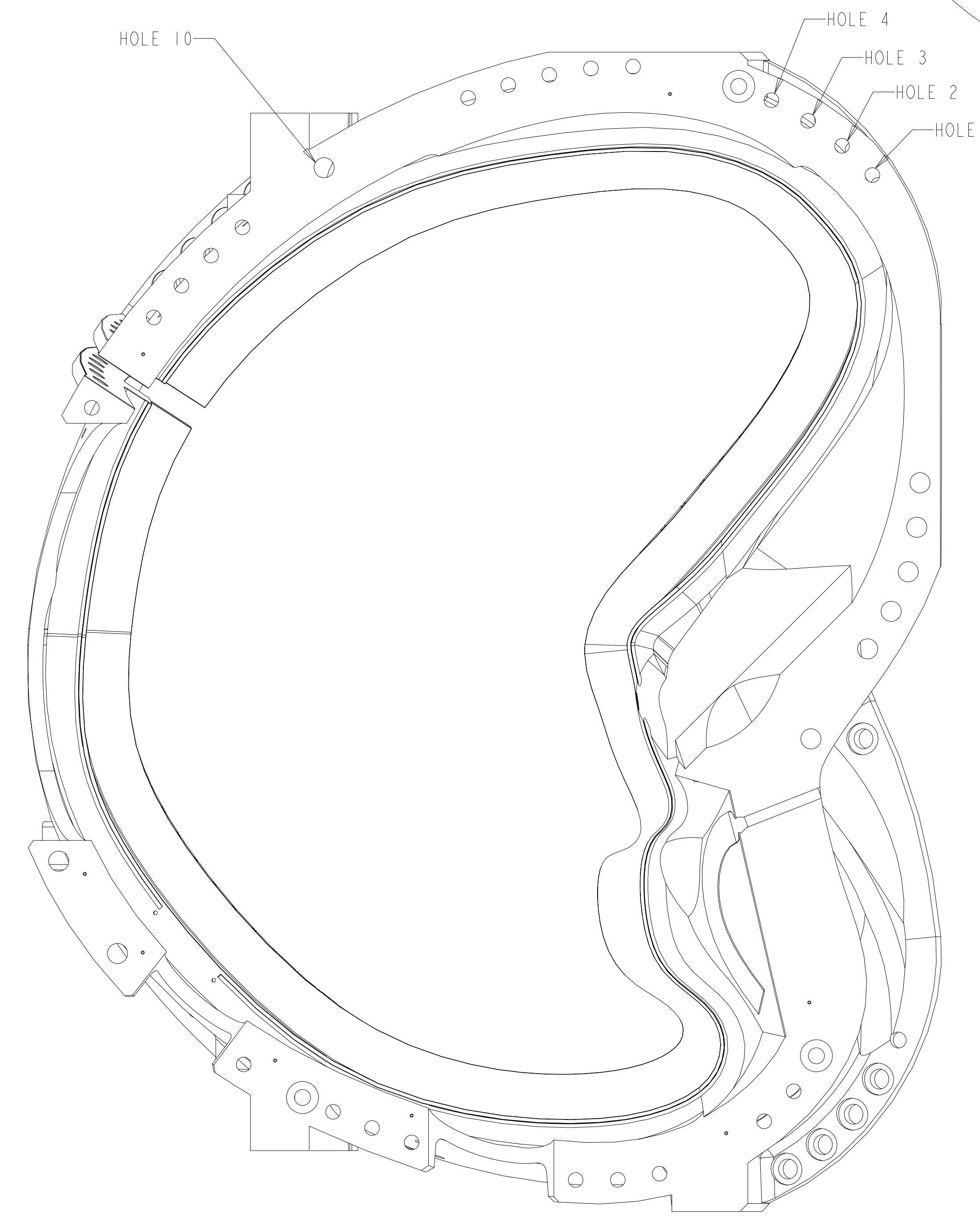
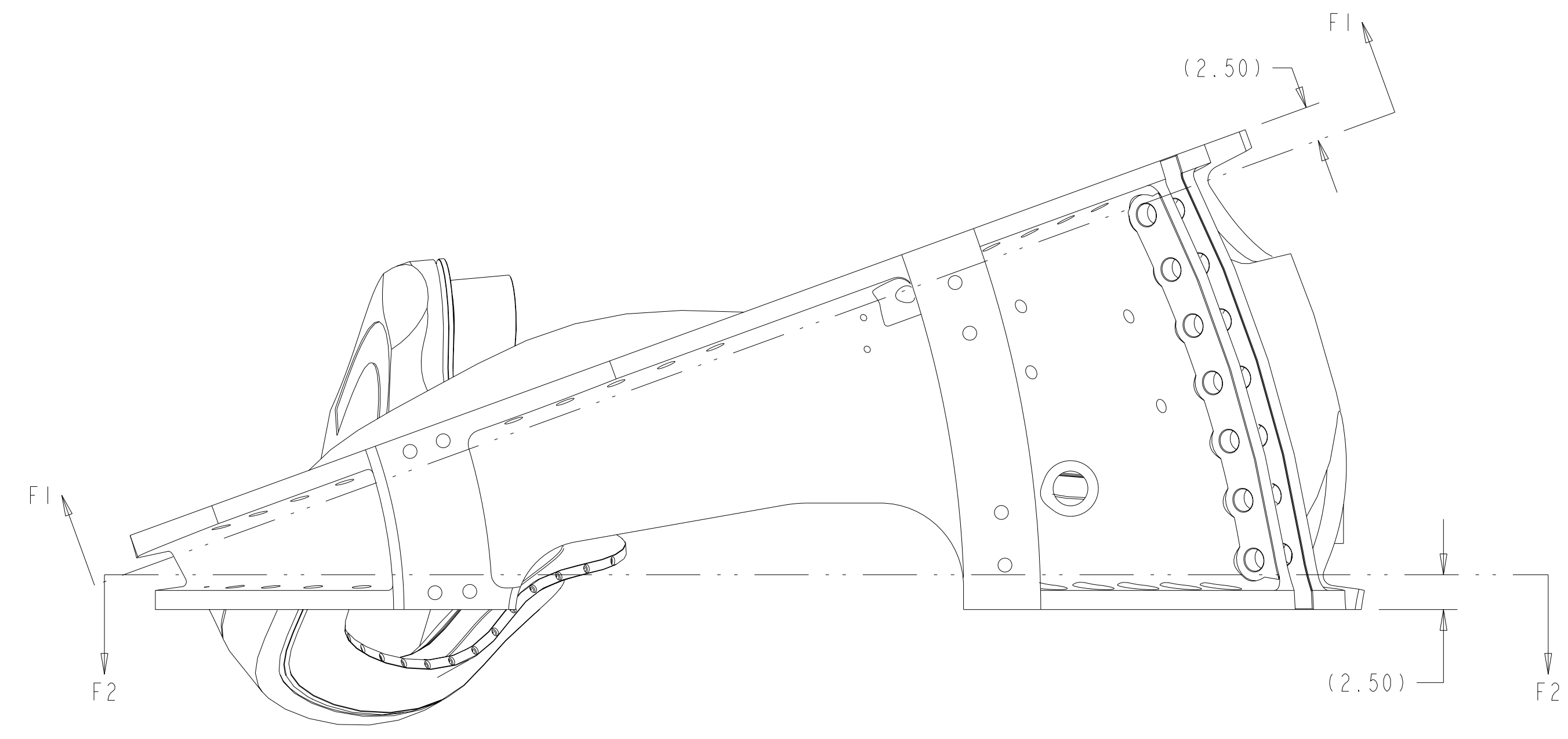
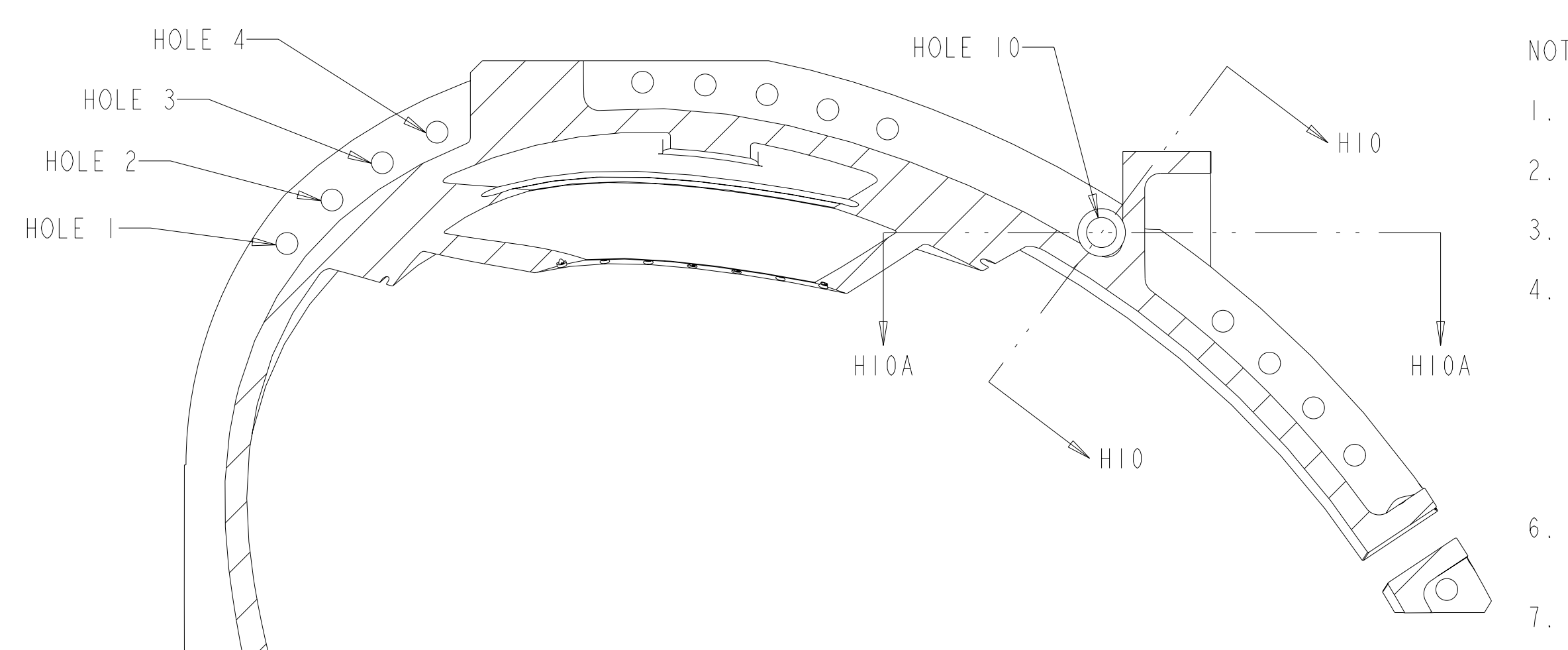

SECTION F1-F1
A-B FLANGE VIEW

A-B FLANGE VIEW
SCALE .125

**RELEASED FOR
FABRICATION / INSTALLATION**
PPPL Drafting:

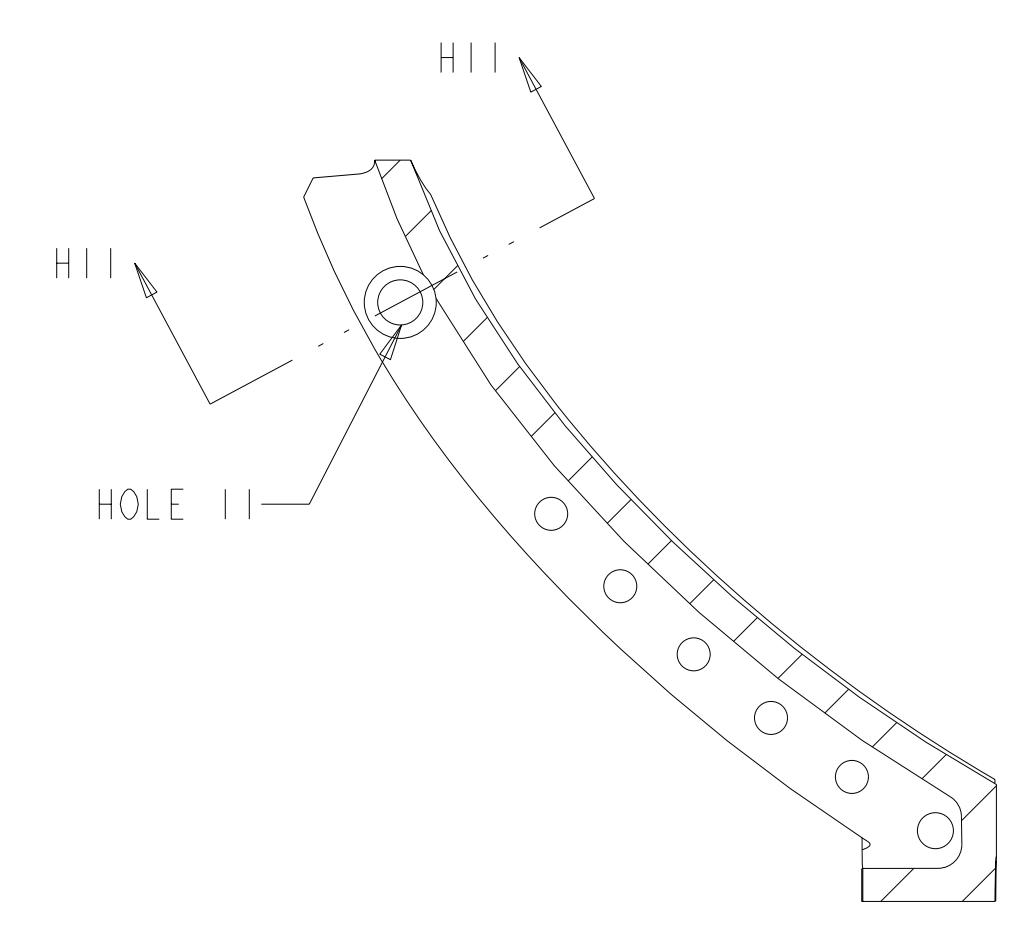

SECTION F2-F2
A-A FLANGE VIEW

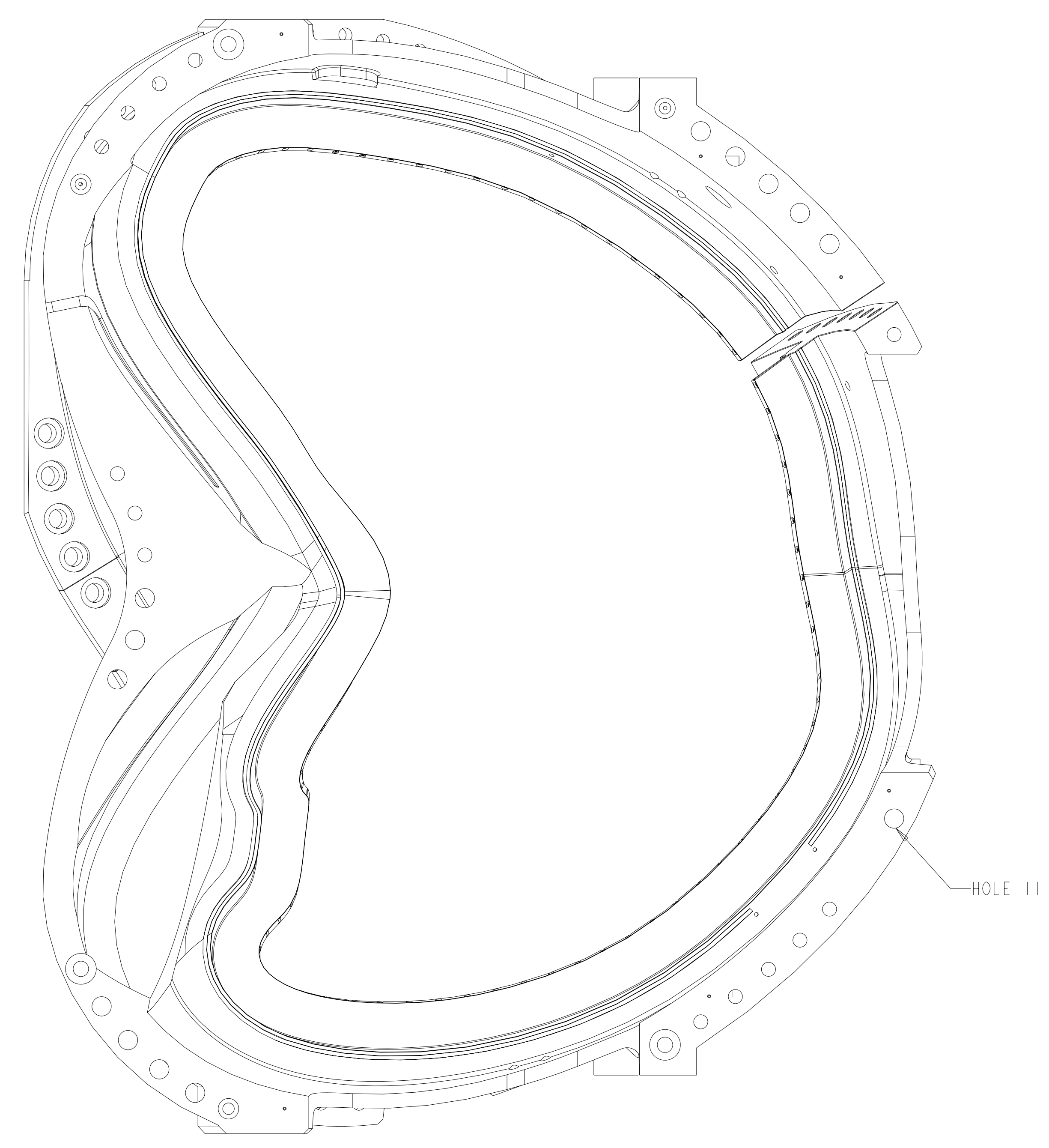

A-A FLANGE VIEW
SCALE .125

HOLE NUMBER IDENTIFICATION IS DEFINED
IN DRAWING SE141-114.DRW

NO REPRESENTATION OR WARRANTY, EXPRESSED OR IMPLIED, IS MADE AS TO THE ACCURACY, COMPLETENESS OR USEFULNESS OF THE INFORMATION OR STATEMENTS CONTAINED IN THESE DRAWINGS, OR THAT THE USE OR DISCLOSURE OF ANY INFORMATION, APPARATUS, METHOD OR PROCESS DISCLOSED IN THESE DRAWINGS MAY NOT INFRINGE PRIVATE RIGHTS OF OTHERS. NO LIABILITY IS ASSUMED WITH RESPECT TO THE USE OF, OR FOR DAMAGES RESULTING FROM THE USE OF, ANY INFORMATION, APPARATUS, METHOD OR PROCESS DISCLOSED IN THESE DRAWINGS. DRAWINGS MADE AVAILABLE FOR PURPOSES, AND ARE TO BE RETURNED UPON REQUEST OF THE FORWARDING CONTRACTOR.

P THIS DRAWING PRODUCED
ON PRO-ENGINEER

REV	DESCRIPTION	BY	DATE	CHK	DEPT	DATE	PE	REQ	DATE	ORNL	DOE	DATE
1	REVISED PER ECN 5273	RLM	7/07	MJC								
0	DELETED NOTE 5, ADDED NOTE 7											
0	ORIGINAL ISSUE	GM	06/07									

SCALE	NOTED	DES	DATE
TOLERANCES UNLESS OTHERWISE SPECIFIED		D WILLIAMSON	06/07
FRACTIONS		G MCGINNIS	06/07
XX DECIMALS	±.01	M COLE	06/07
XXX DECIMALS	±.005		
ANGLES	±0'15"		
BREAK SHARP EDGES	06 MAX		
FINISH	.125 UNLESS OTHERWISE SPECIFIED		

DES	DATE	DRW	DATE	CHK	DATE	SECT	DEPT	PPPL	DRFT	DATE	VERSION NO.	PLANT	BLDG	FL	SHT	OF	TYPE	CLASS
D WILLIAMSON	06/07	G MCGINNIS	06/07	M COLE	06/07			J SIEGEL	06/07		2	ORNL	5700	3	1	2	S	U
												SE141-114G						

Oak Ridge National Laboratory
managed for the DEPARTMENT OF ENERGY under
U.S. GOVERNMENT CONTRACT DE-AC05-00OR22725
UT-BATTELLE, LLC. Oak Ridge, Tennessee
PROJECT NAME: NATIONAL COMPACT STELLARATOR EXPERIMENT
TYPE "A" MODULAR COIL
SUPER NUT CLEARANCE

8

7

6

5

4

3

2

1

SE141-114G

A

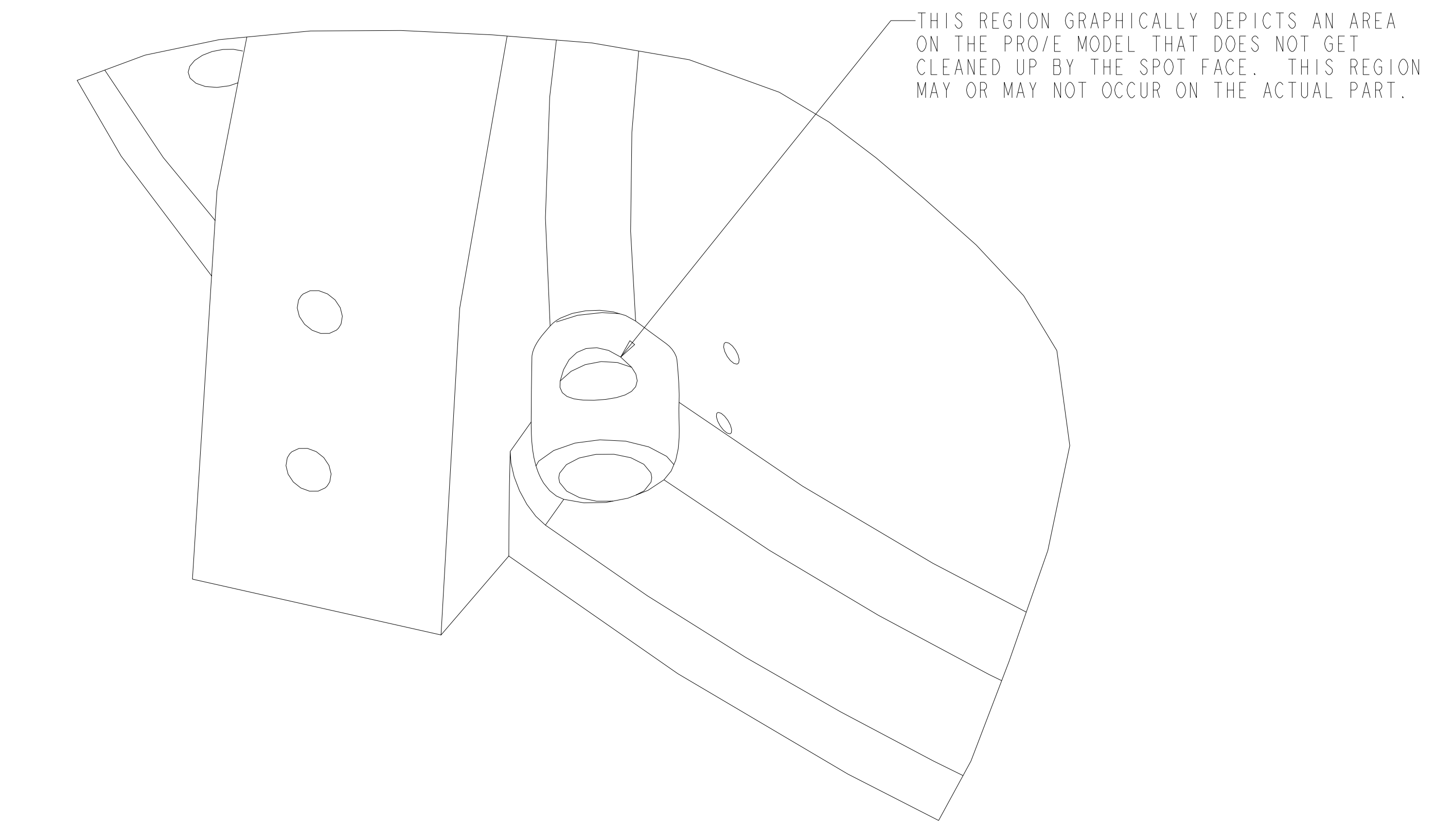

THIS REGION GRAPHICALLY DEPICTS AN AREA ON THE PRO/E MODEL THAT DOES NOT GET CLEANED UP BY THE SPOT FACE. THIS REGION MAY OR MAY NOT OCCUR ON THE ACTUAL PART.

ISOMETRIC VIEW - HOLE 10
SCALE 0.500

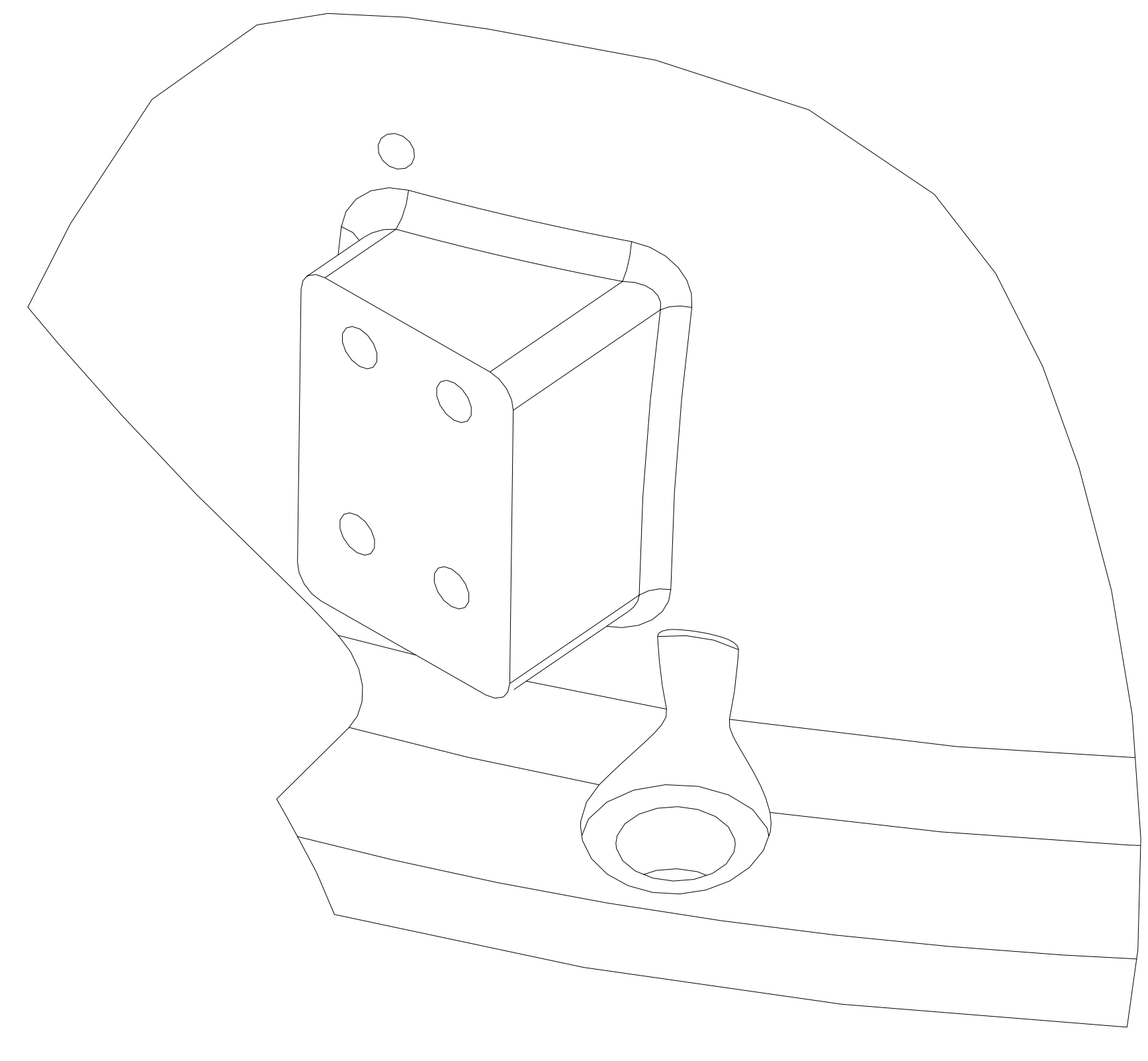

ISOMETRIC VIEW - HOLE 11
SCALE 0.500

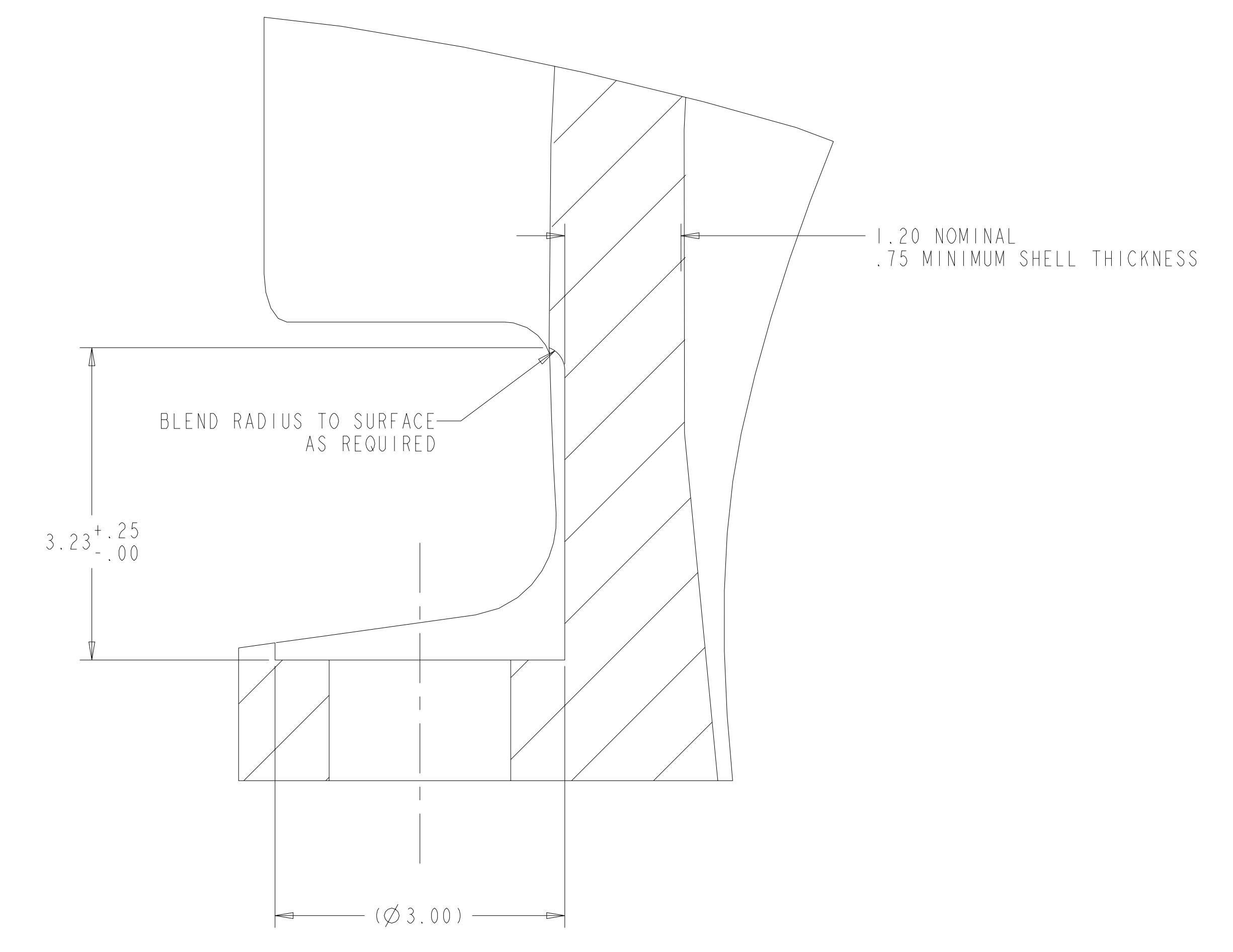

SECTION H11-H11 AT HOLE 11
SCALE 1.000
SEE NOTE 4

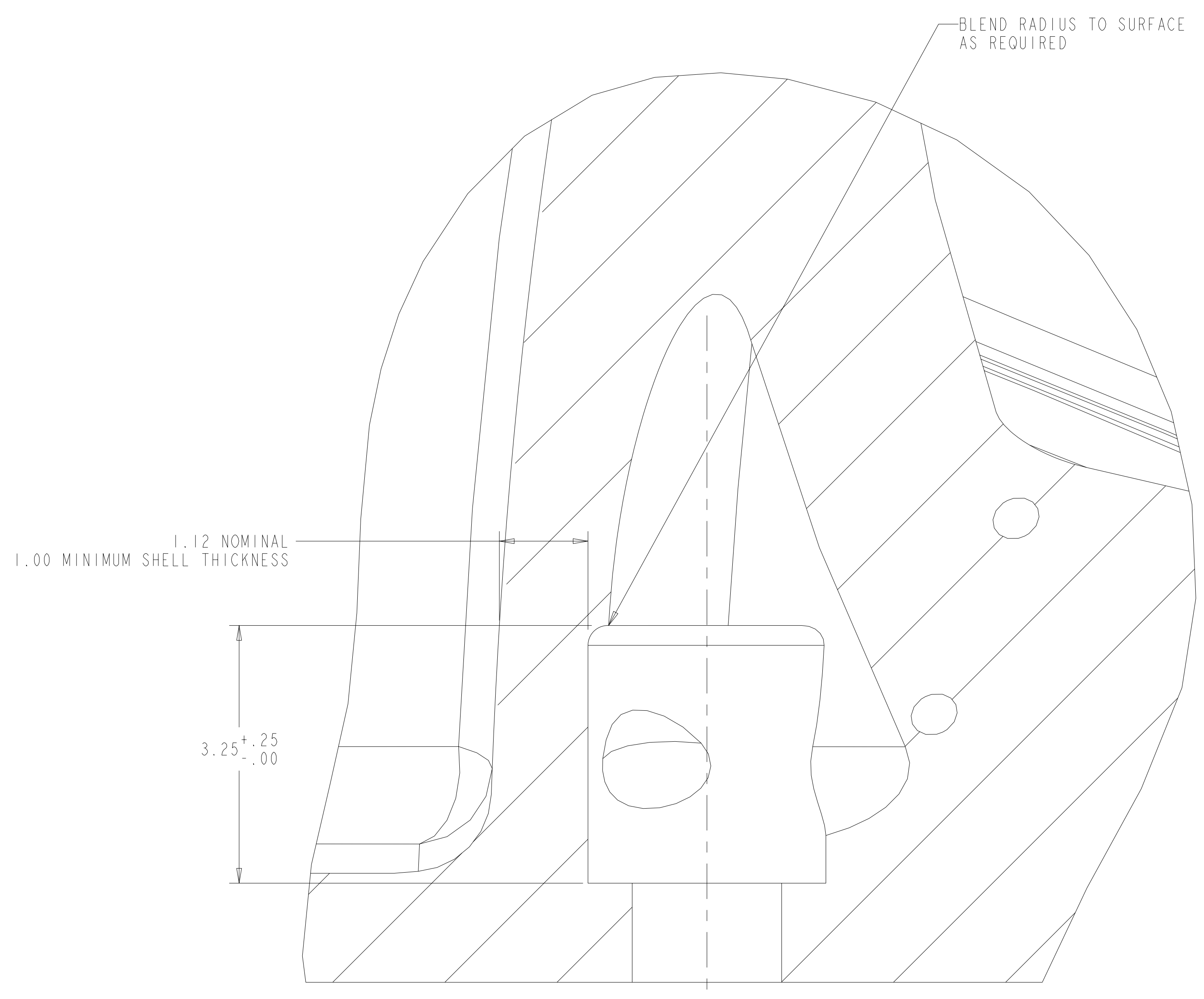

SECTION H10A-H10A
SCALE 1.000
SEE NOTE 4

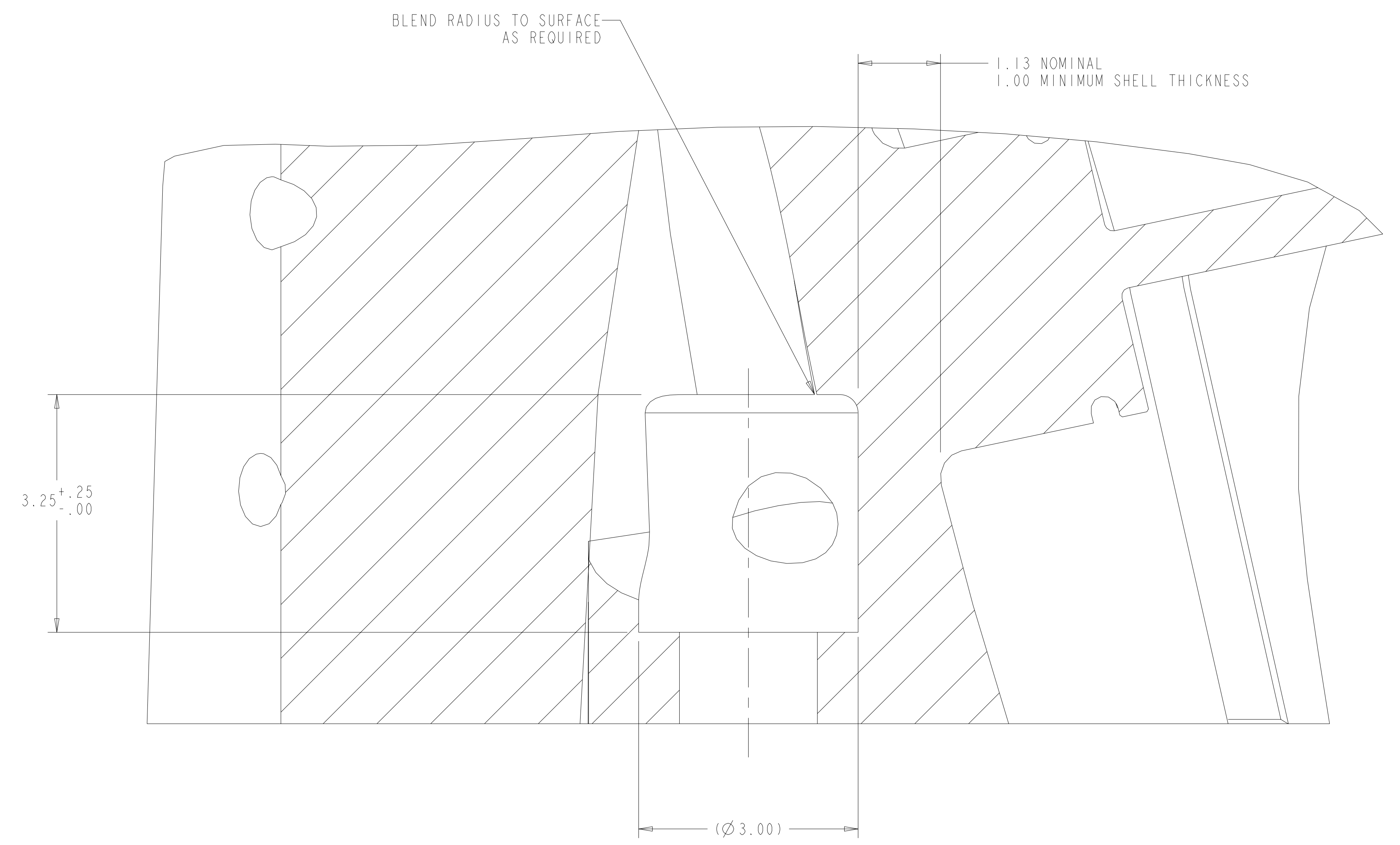

SECTION H10-H10 AT HOLE 10
SCALE 1.000
SEE NOTE 4

RELEASED FOR FABRICATION / INSTALLATION
PPPL Drafting:

Oak Ridge National Laboratory managed for the DEPARTMENT OF ENERGY under U.S. GOVERNMENT contract DE-AC05-00OR22725 UT-BATTELLE, LLC, Oak Ridge, Tennessee PROJECT NAME									
NATIONAL COMPACT STELLARATOR EXPERIMENT									
TYPE "A" MODULAR COIL SUPER NUT CLEARANCE									
VERSION NO.	PLANT	BLDG	FL	SHT	OF	TYPE	CLASS		
2	ORNL	5700	3	2	2	S	U		
RELEASE LEVEL		SE141-114G						REV	
Fabrication								0	