

- NOTES
1. DRAWING PREPARED IN ACCORDANCE WITH ASME Y14.100-2004.
 2. INTERPRET DIMENSIONS AND TOLERANCES PER ASME Y14.5M-1994.
 3. DIMENSIONS ARE IN INCHES
 4. MINIMIZE MATERIAL REMOVAL FOR ALL HOLE LOCATIONS SHOWN TO PROVIDE CLEARANCE FOR SUPERNUT. CLEARANCE IS DEFINED AS PLACING A $\varnothing 3.00$ " X 3.25" LONG CYLINDER AT EACH $\varnothing 3.00$ " SPOT FACE. THE CYLINDER SHALL NOT INTERFERE WITH THE WINDING FORM.
 5. THIS DRAWING MODIFIES THE EXISTING TYPE "B" WINDING FORM AS DEFINED IN DRAWING SE141-115.DRW.
 6. GRIND SHELL AS REQUIRED TO ALLOW INSTALLATION OF THE HEX NUT AND/OR SUPERNUT (SEE DRAWING SE140-190). ENGINEERING APPROVAL REQUIRED IF SHELL THICKNESS IS LESS THAN 1" AS A RESULT OF GRINDING.

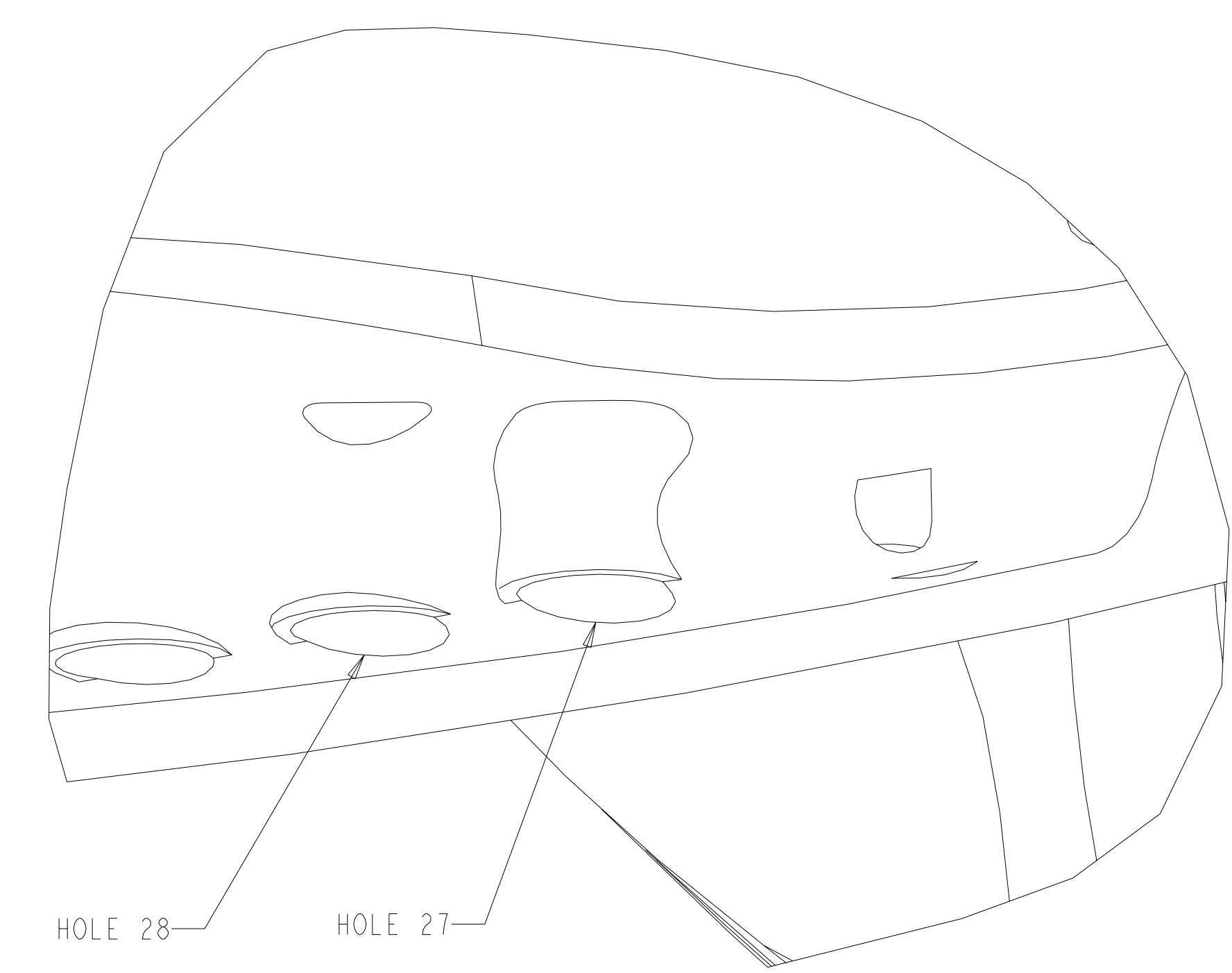

ISOMETRIC VIEW - HOLE 27
SCALE 0.500

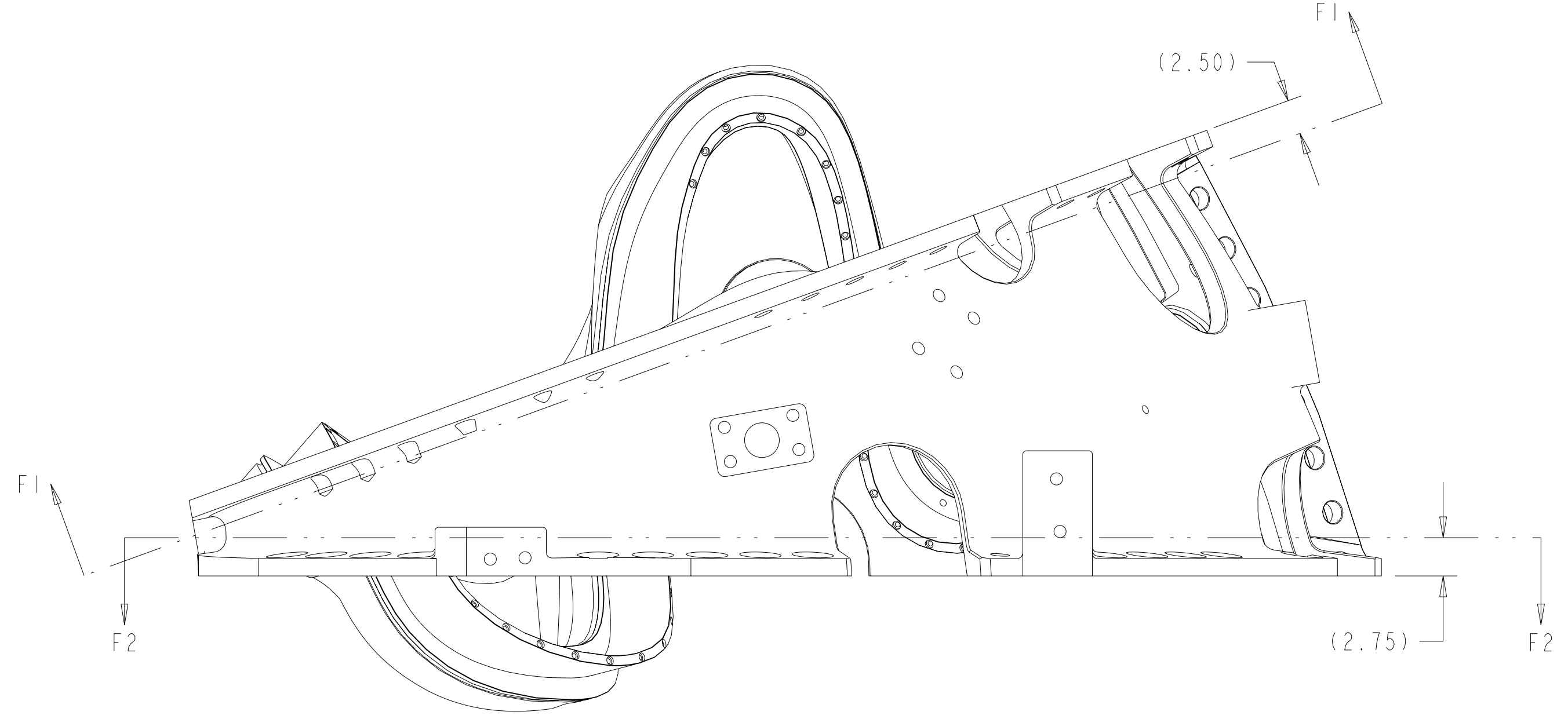
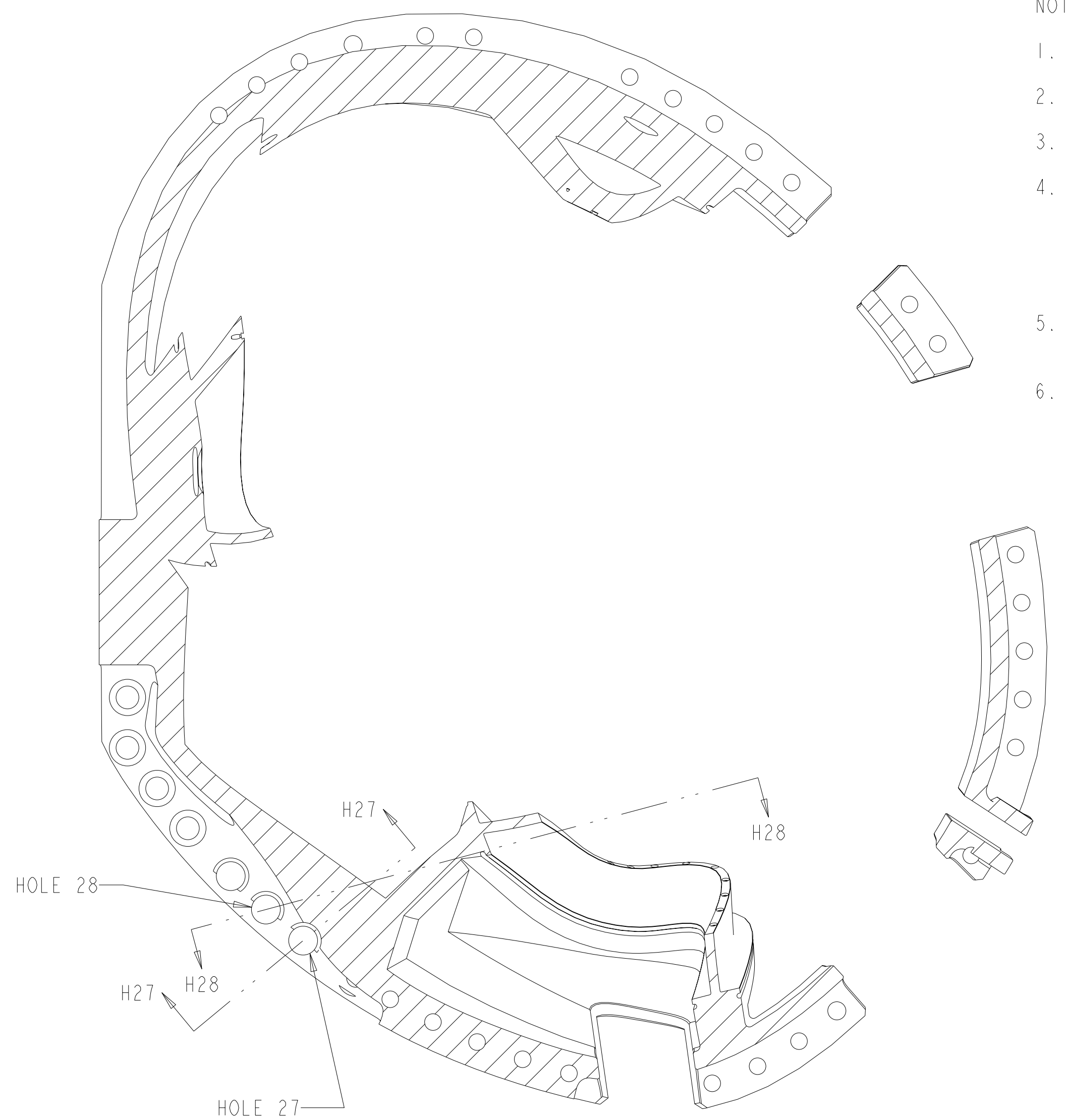

SECTION F1-F1
BC FLANGE VIEW

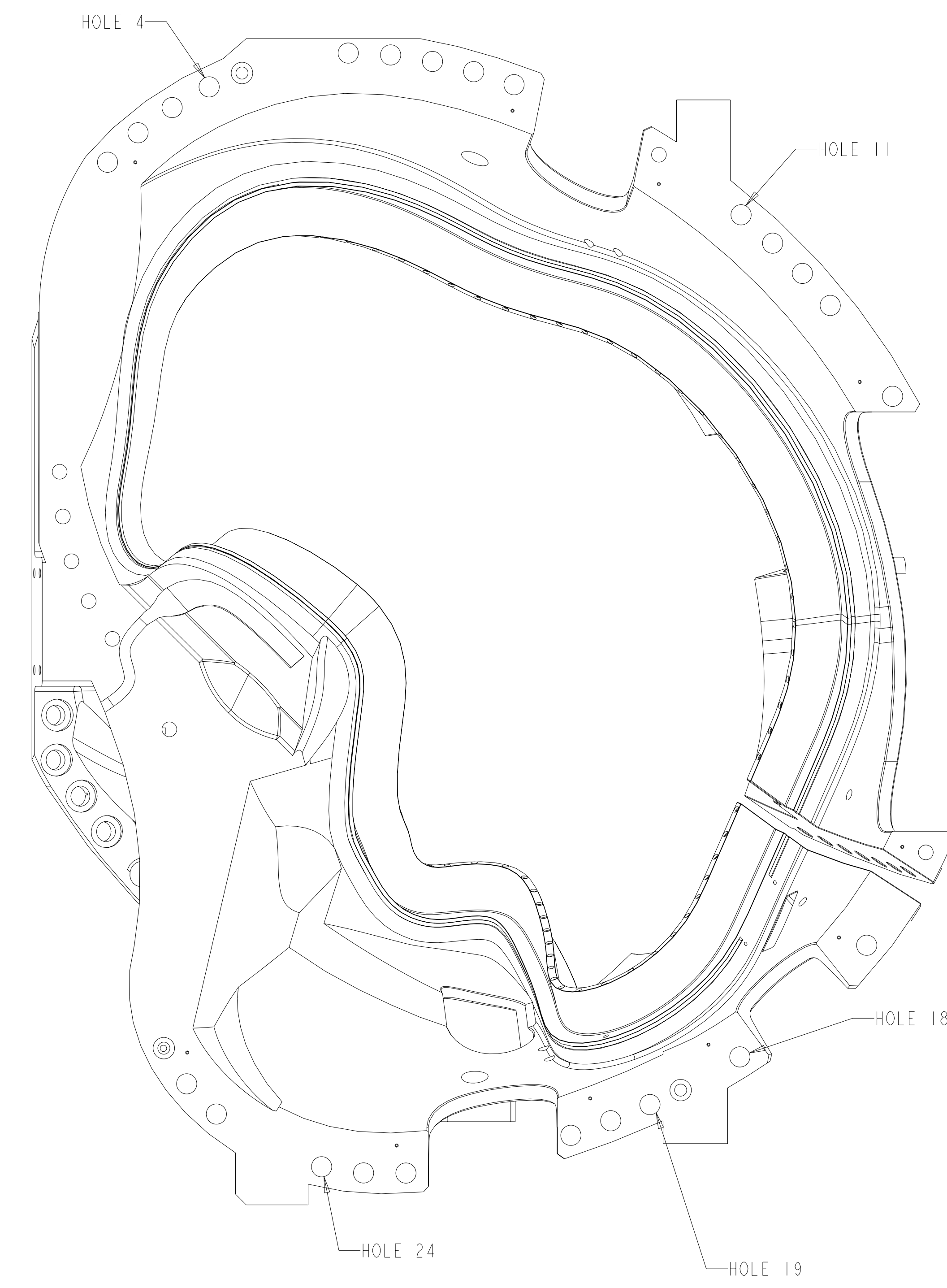

B-A FLANGE VIEW
SCALE .125

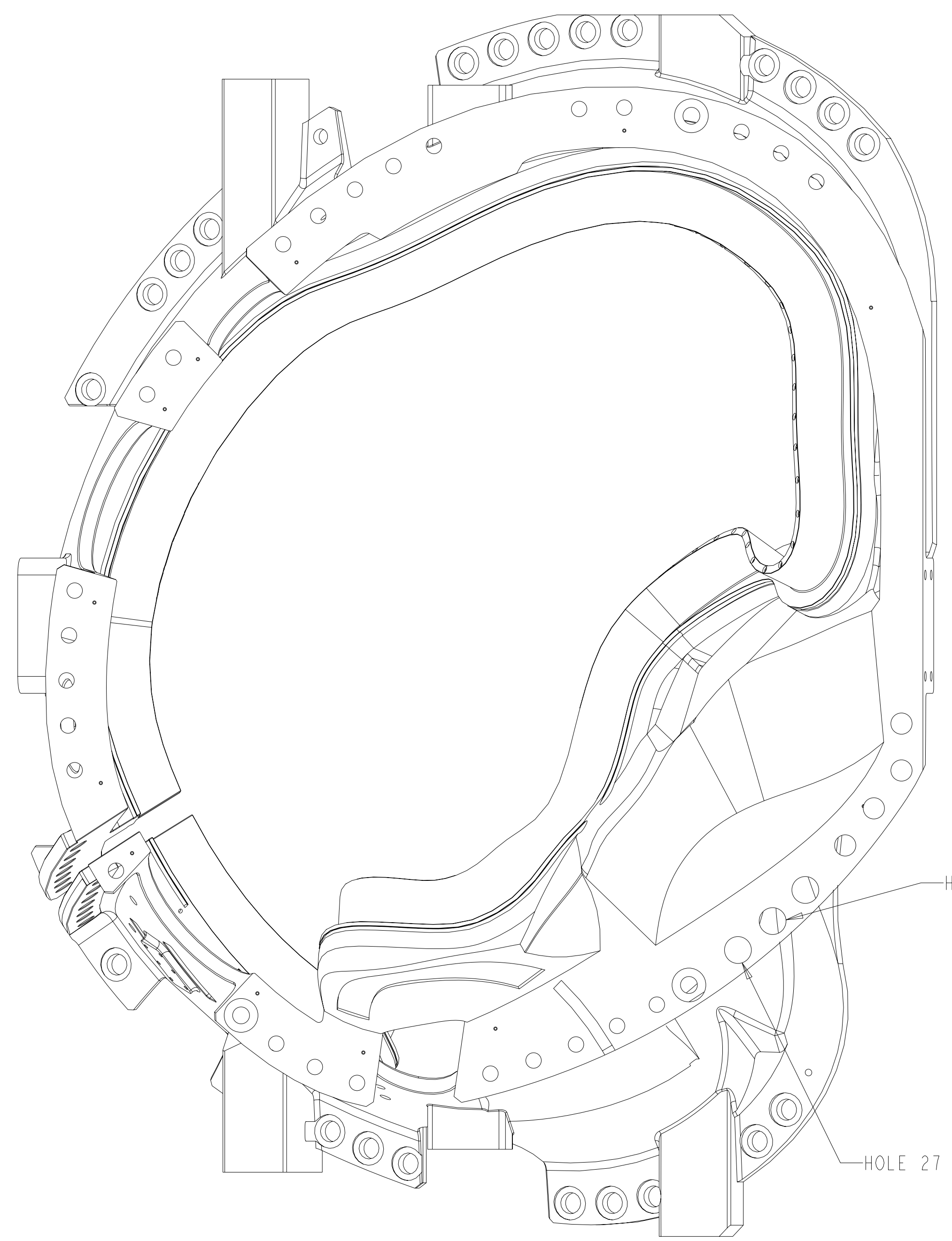

B-C FLANGE VIEW
SCALE .125

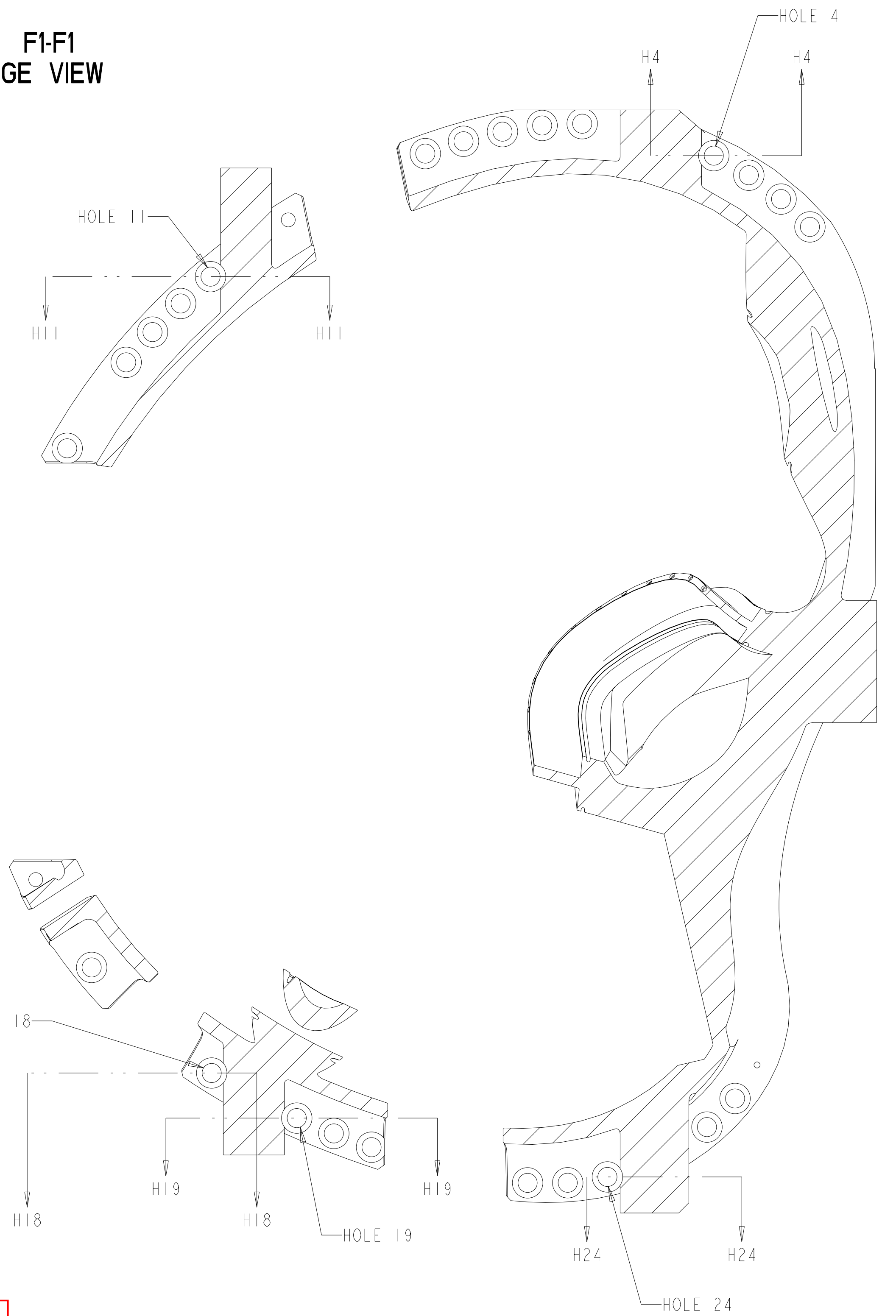

SECTION F2-F2
BA FLANGE VIEW

RELEASED FOR
FABRICATION / INSTALLATION
PPPL Drafting

NO REPRESENTATION OR WARRANTY, EXPRESSED OR IMPLIED, IS MADE AS TO THE ACCURACY, COMPLETENESS OR USEFULNESS OF THE INFORMATION OR STATEMENTS CONTAINED IN THESE DRAWINGS, OR THAT THE USE OR DISCLOSURE OF ANY INFORMATION, APPARATUS, METHOD OR PROCESS DISCLOSED IN THESE DRAWINGS MAY NOT INFRINGE PRIVATE RIGHTS OF OTHERS. NO LIABILITY IS ASSUMED WITH RESPECT TO THE USE OF, OR FOR DAMAGES RESULTING FROM THE USE OF, ANY INFORMATION, APPARATUS, METHOD OR PROCESS DISCLOSED IN THESE DRAWINGS. DRAWINGS MADE AVAILABLE FOR PURPOSES, AND ARE TO BE RETURNED UPON REQUEST OF THE FORWARDING CONTRACTOR.

P THIS DRAWING PRODUCED ON PRO-ENGINEER

HOLE NUMBER IDENTIFICATION IS DEFINED IN DRAWING SE141-115.DRW

REV	DESCRIPTION	BY	DATE	CHK	DEPT	DATE	PE	REQ	DATE	ORNL	DOE	DATE
1	REVISED PER ECN 5273	RLM	7/07	MJC								
0	ADDED NOTE 6											
0	ORIGINAL ISSUE	GM	06/07									

SCALE	NOTED
TOLERANCES UNLESS OTHERWISE SPECIFIED	
FRACTIONS	±.01
XX DECIMALS	±.005
XXX DECIMALS	±0°15'
ANGLES	
BREAK SHARP EDGES OR MAX	
FINISH	.125 UNLESS OTHERWISE SPECIFIED

DES: D WILLIAMSON	06/07	UT-BATTELLE NATIONAL COMPACT STELLARATOR EXPERIMENT					
DRW: G MCGINNIS	06/07						
CHK: M COLE	06/07						
PPPL DRFT J SIEGEL		06/07					
VERSION NO.	PLANT	BLDG	FL	SHT	OF	TYPE	CLASS
	ORNL	5700	3	1	2	S	U
RELEASE LEVEL		SE141-115G					
DRAWING APPROVALS		Fabrication					

8

7

6

5

4

3

2

1

NEXT ASS'Y: 1 FINAL ASS'Y:

H

H

G

G

F

F

E

E

D

D

C

C

B

B

A

A

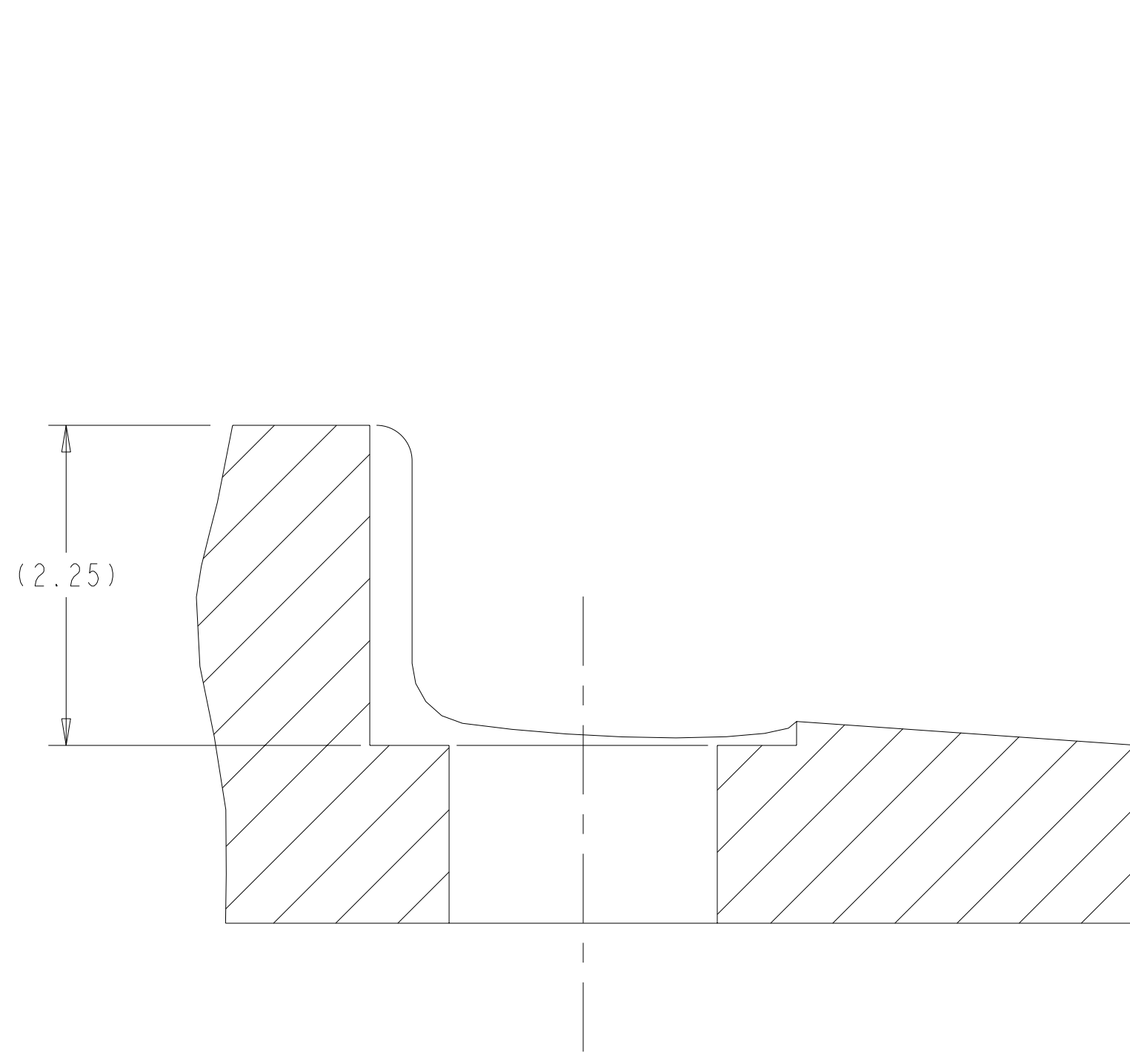

SECTION H4-H4 AT HOLE 4
SCALE 1.000

SEE NOTE 4

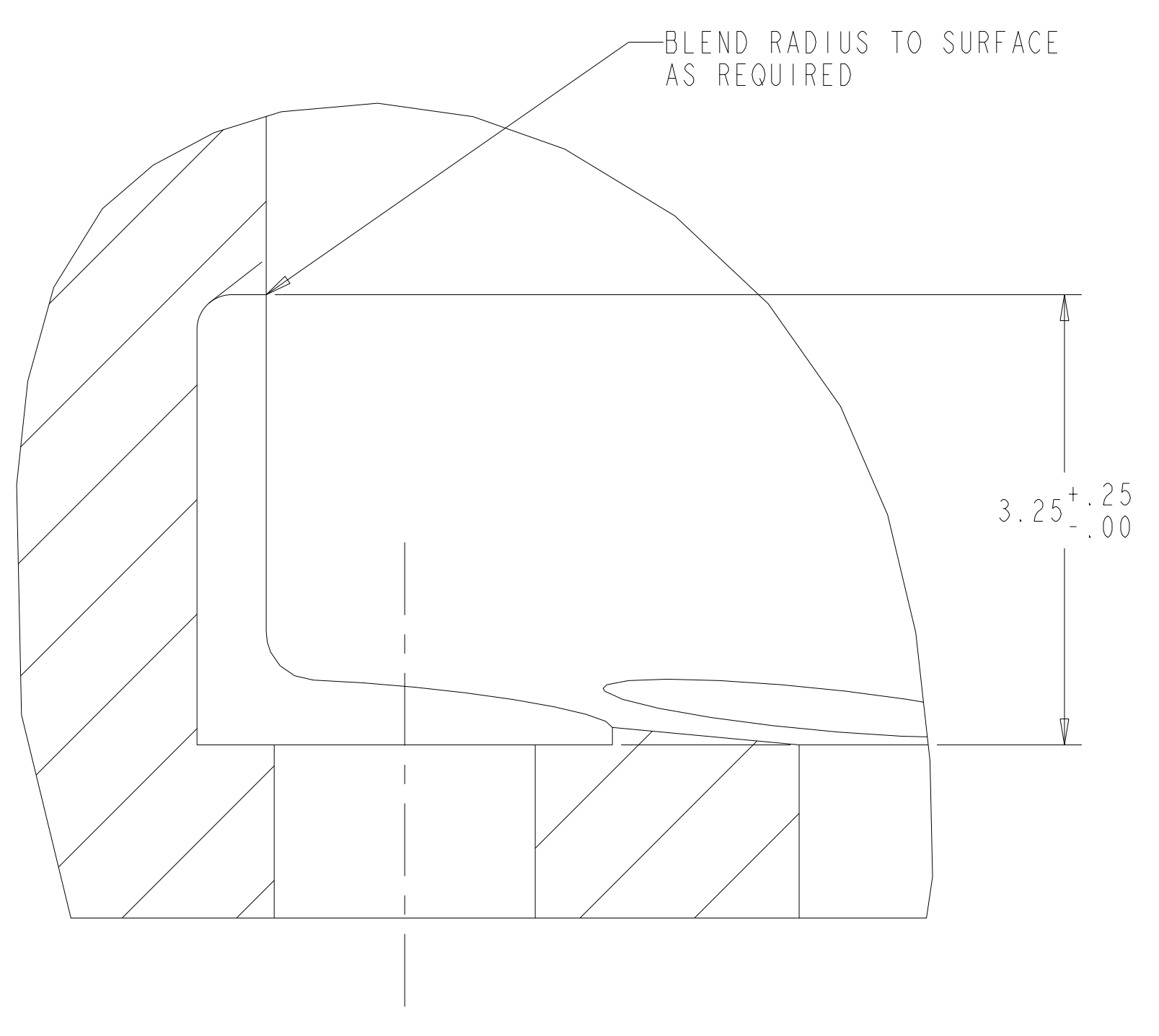

SECTION H11-H11 AT HOLE 11
SCALE 1.000

SEE NOTE 4

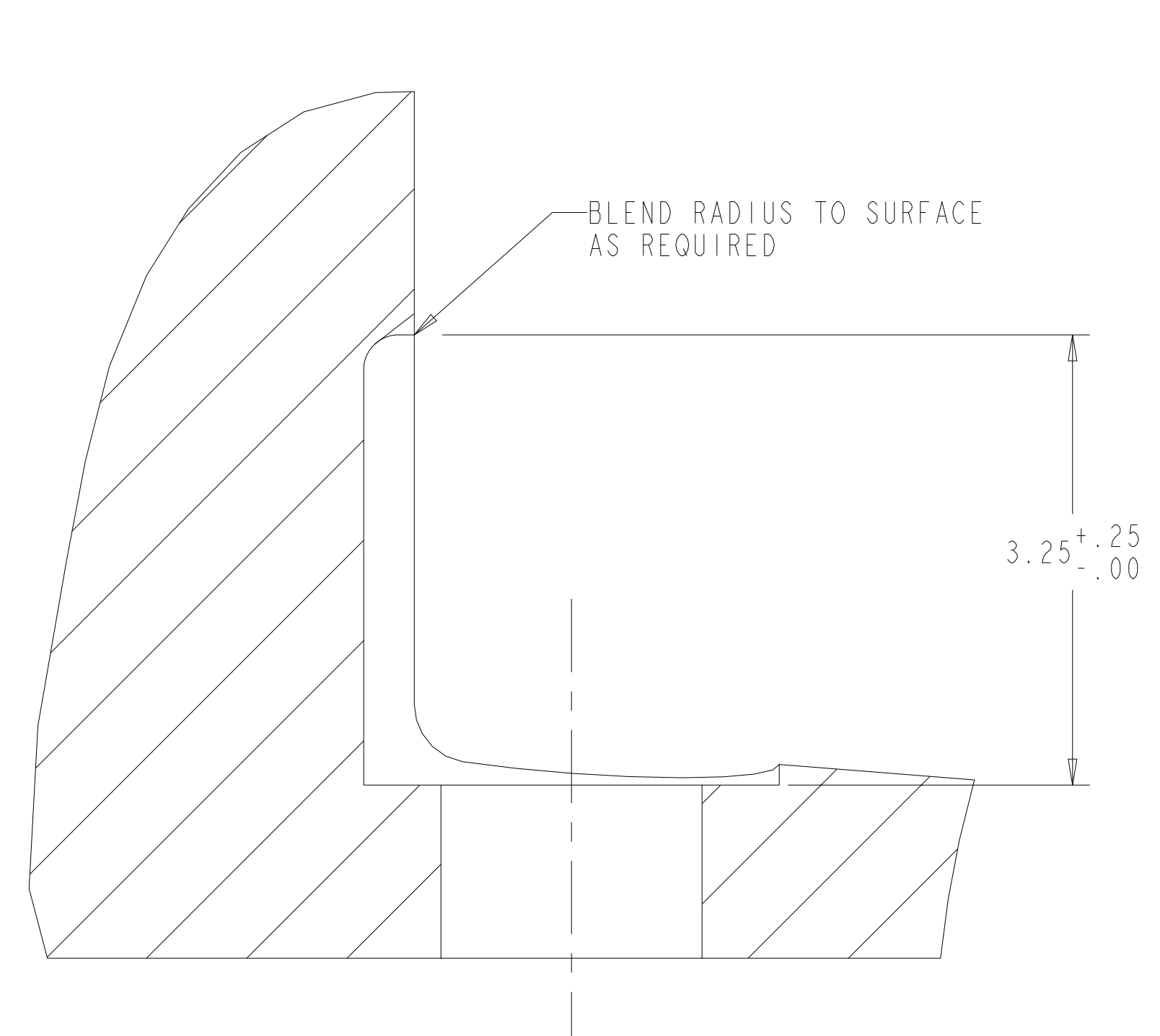

SECTION H18-H18 AT HOLE 18
SCALE 1.000

SEE NOTE 4

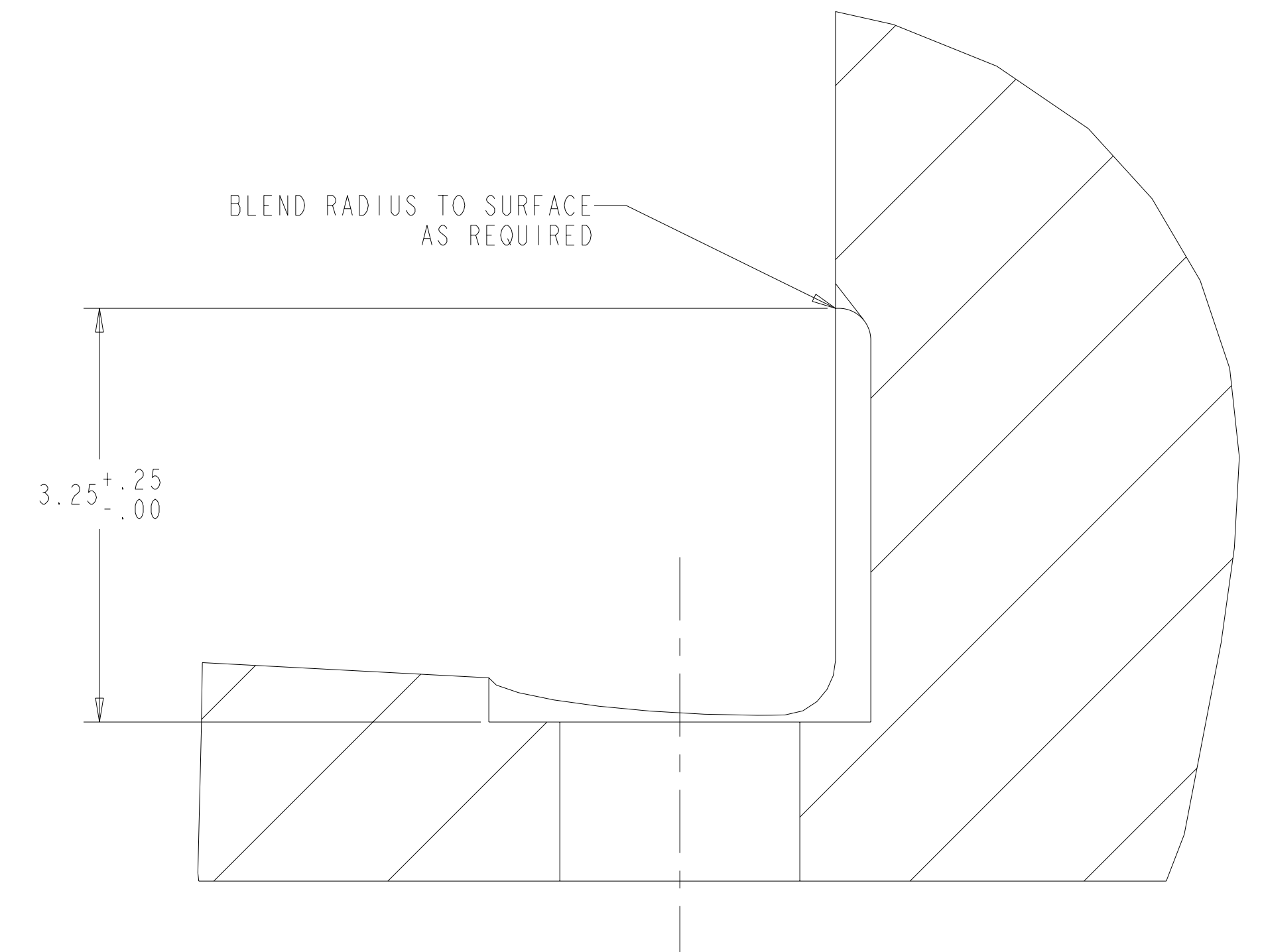

SECTION H19-H19 AT HOLE 19
SCALE 1.000

SEE NOTE 4

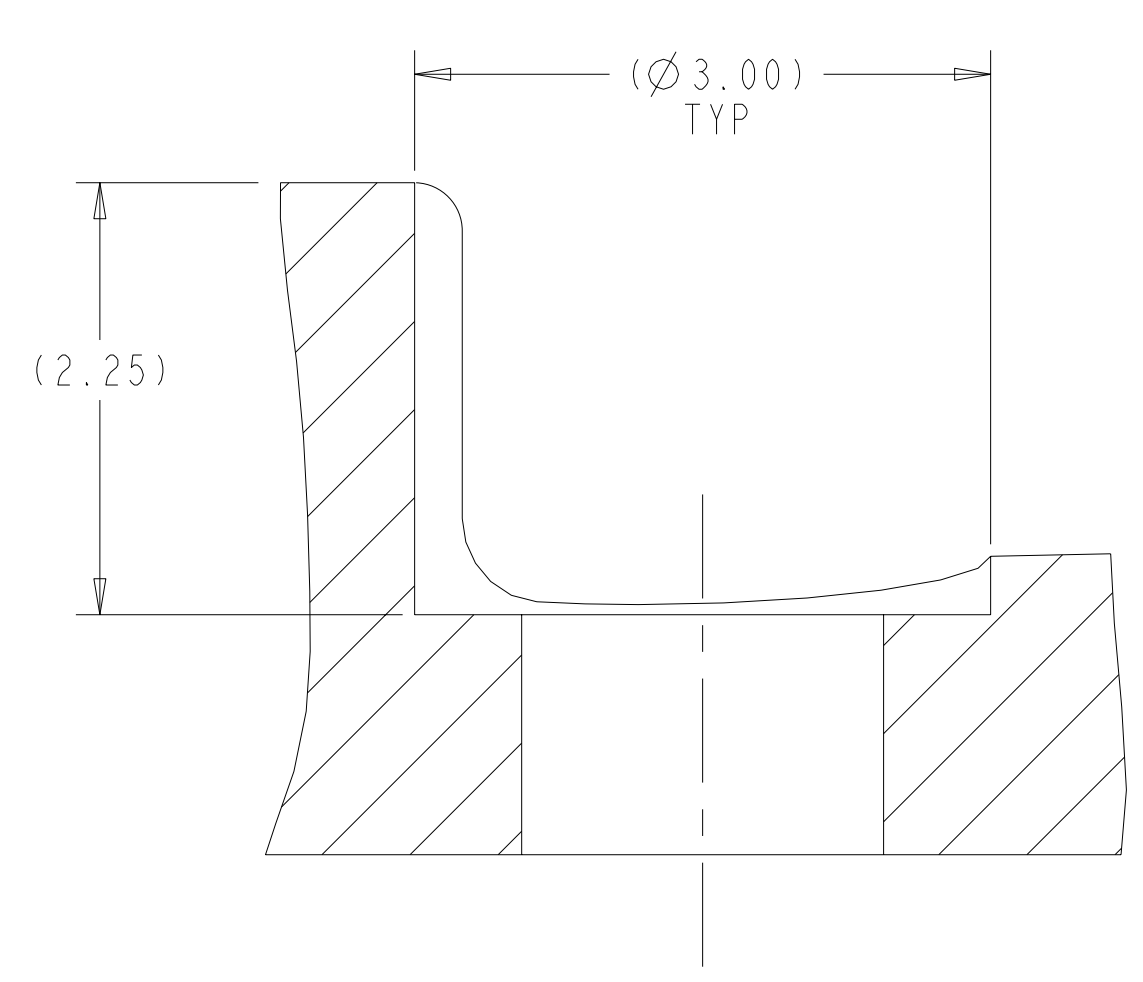

SECTION H24-H24 AT HOLE 24
SCALE 1.000

SEE NOTE 4

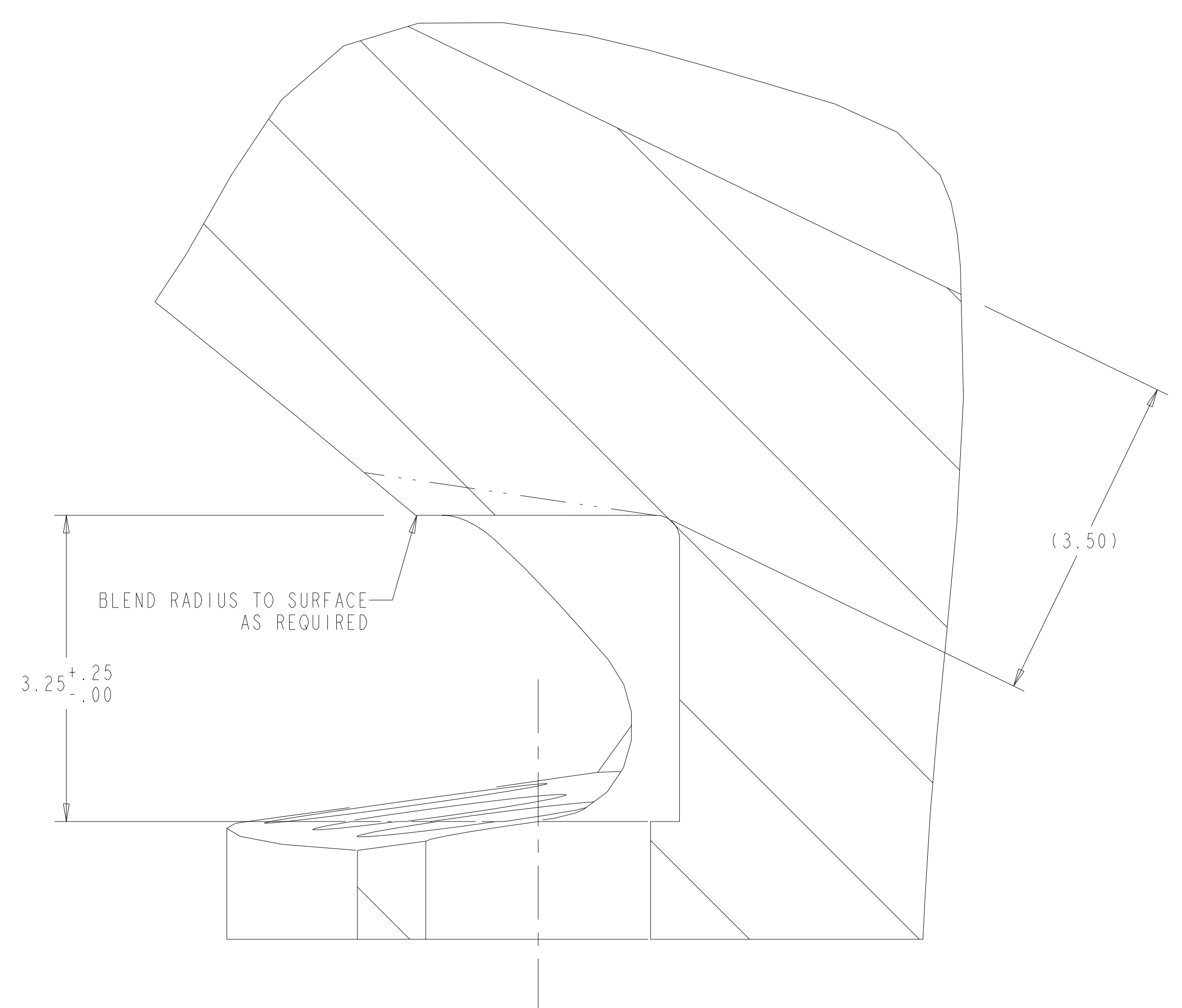

SECTION H27-H27 AT HOLE 27
SCALE 1.000

SEE NOTE 4

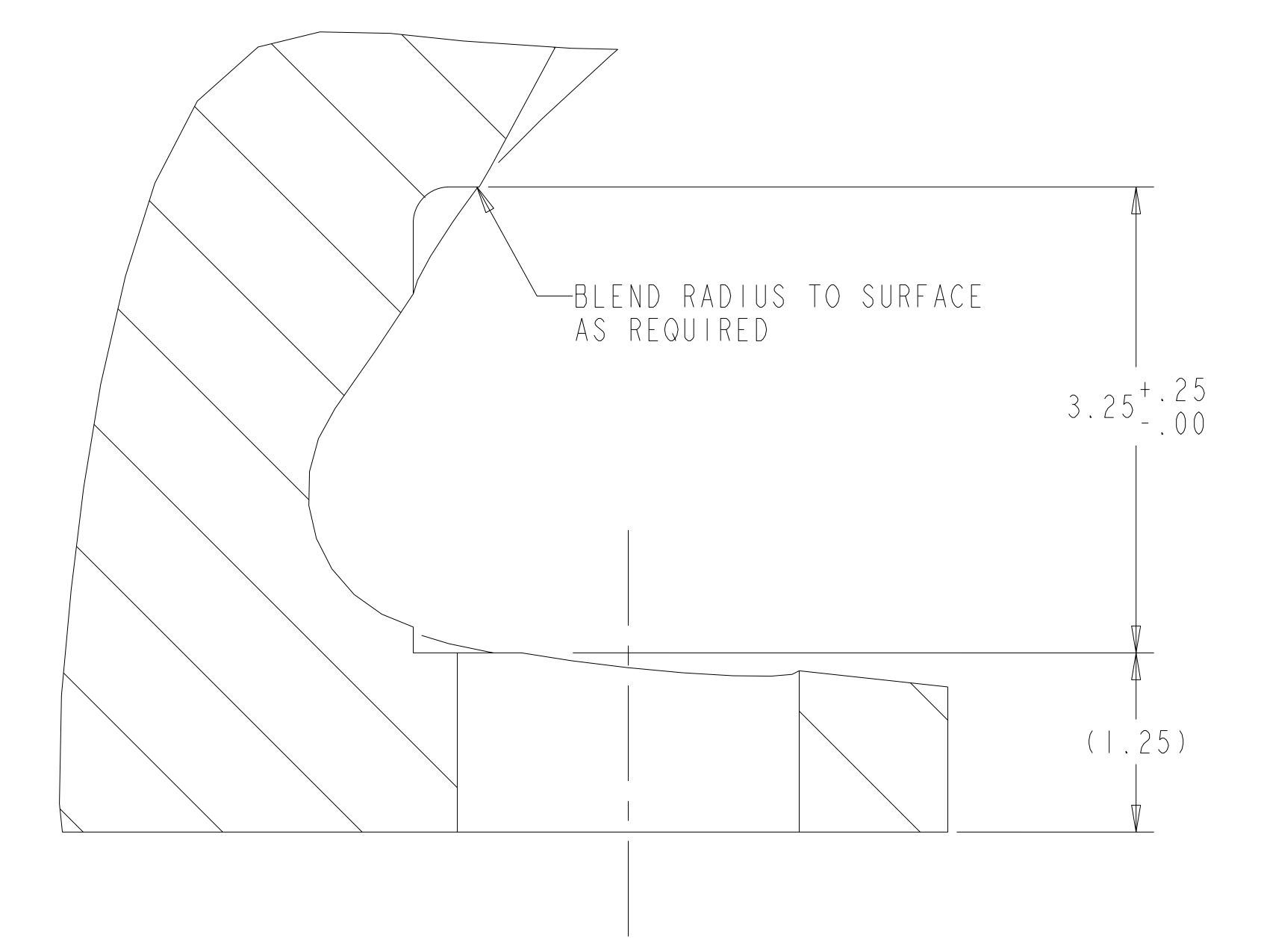

SECTION H28-H28 AT HOLE 28
SCALE 1.000

SEE NOTE 4

**RELEASED FOR
FABRICATION / INSTALLATION**
PPPL Drafting:

Oak Ridge National Laboratory managed for the DEPARTMENT OF ENERGY under U.S. GOVERNMENT contract DE-AC05-00OR22725 UT-BATTELLE, LLC, Oak Ridge, Tennessee PROJECT NAME:										
UT-BATTELLE NATIONAL COMPACT STELLARATOR EXPERIMENT										
TYPE "B" MODULAR COIL SUPER NUT CLEARANCE										
VERSION NO.	PLANT	BLDG	FL	SHT	OF	TYPE	CLASS			
1	ORNL	5700	3	2	2	S	U			
RELEASE LEVEL		SE141-115G						REV		
Fabrication								0		

8

7

6

5

4

3

2

1

SE141-115G