

8

7

6

5

4

3

2

1

NEXT ASS'Y:

FINAL ASS'Y:

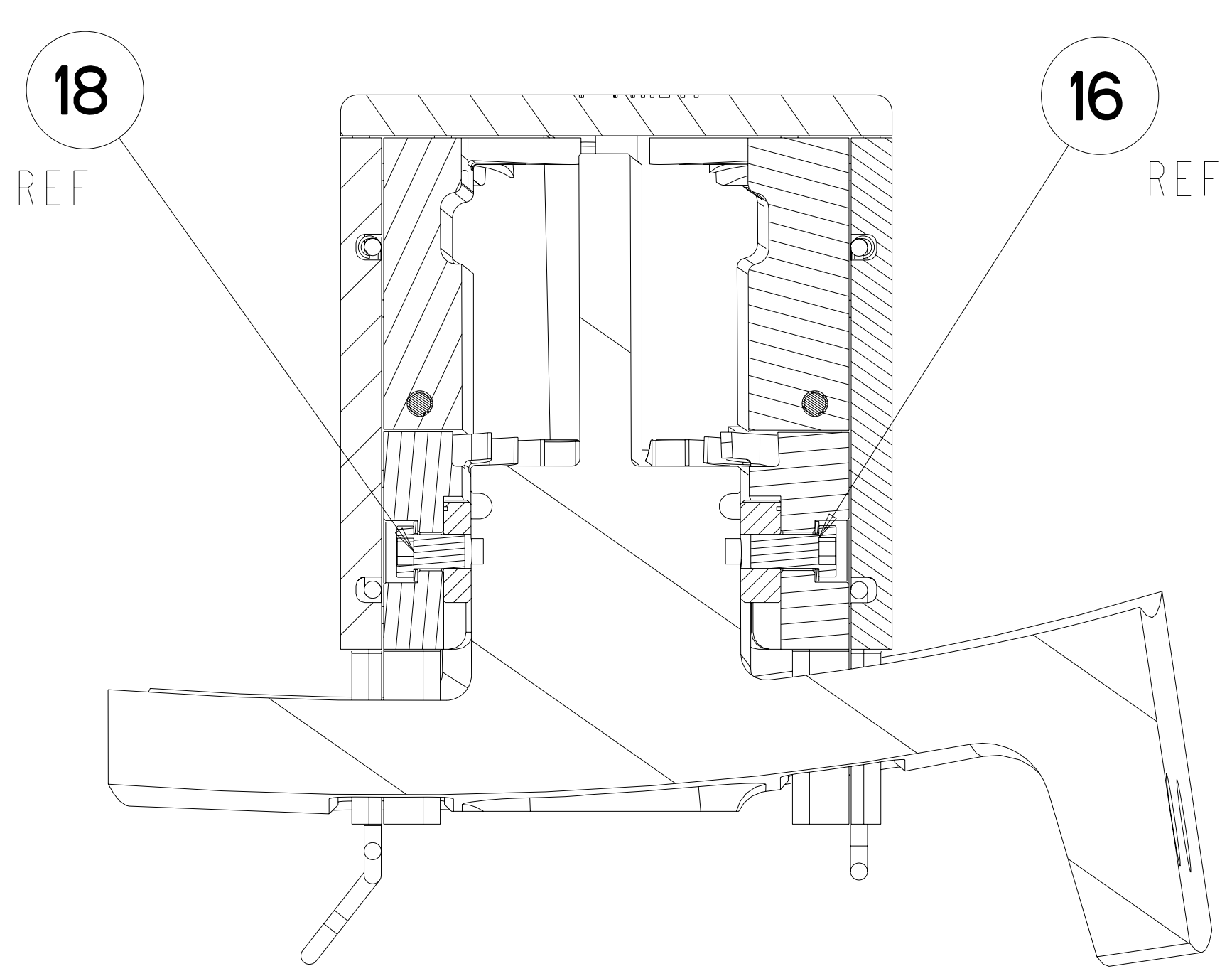

SECTION C-C

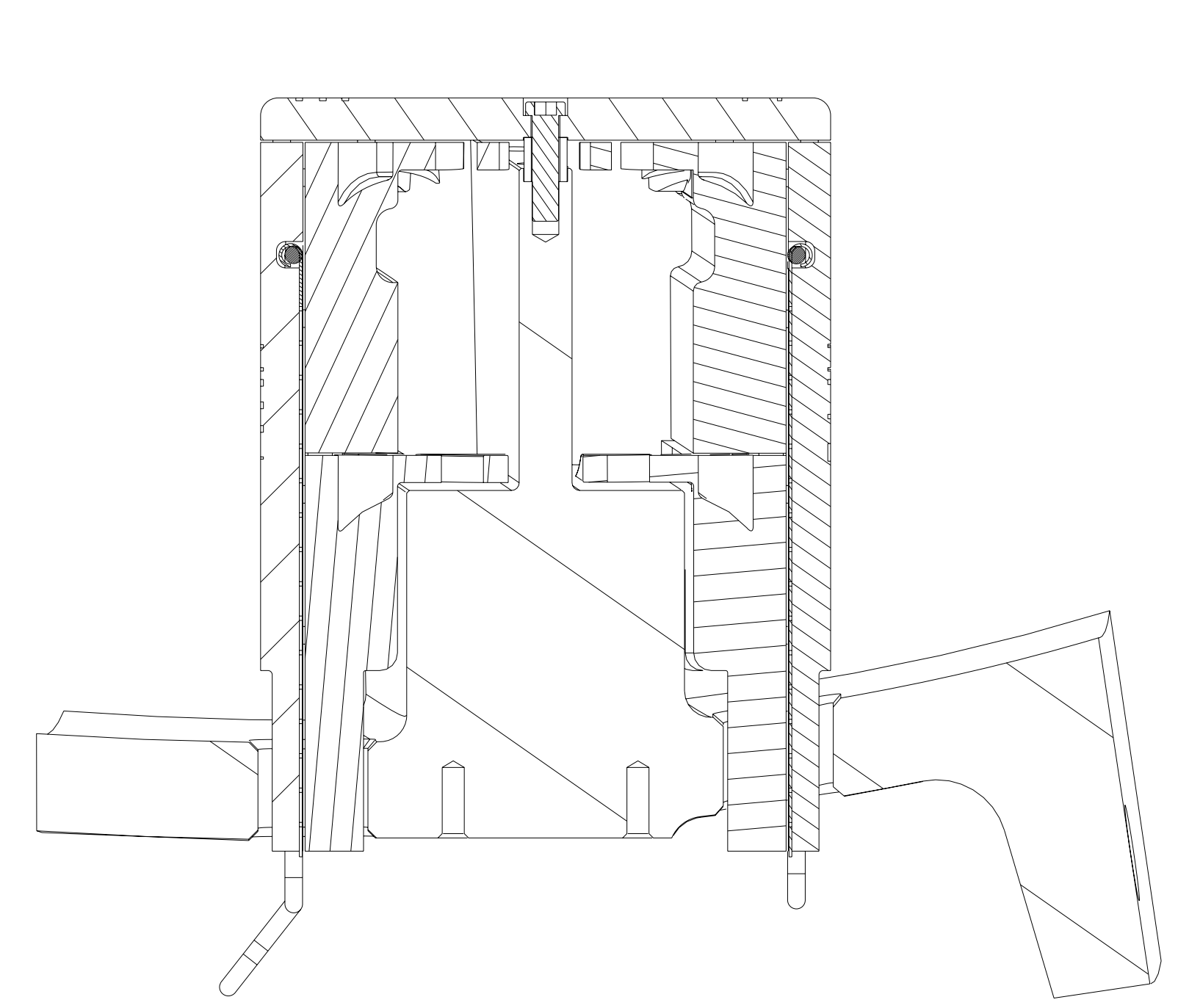

SECTION A-A

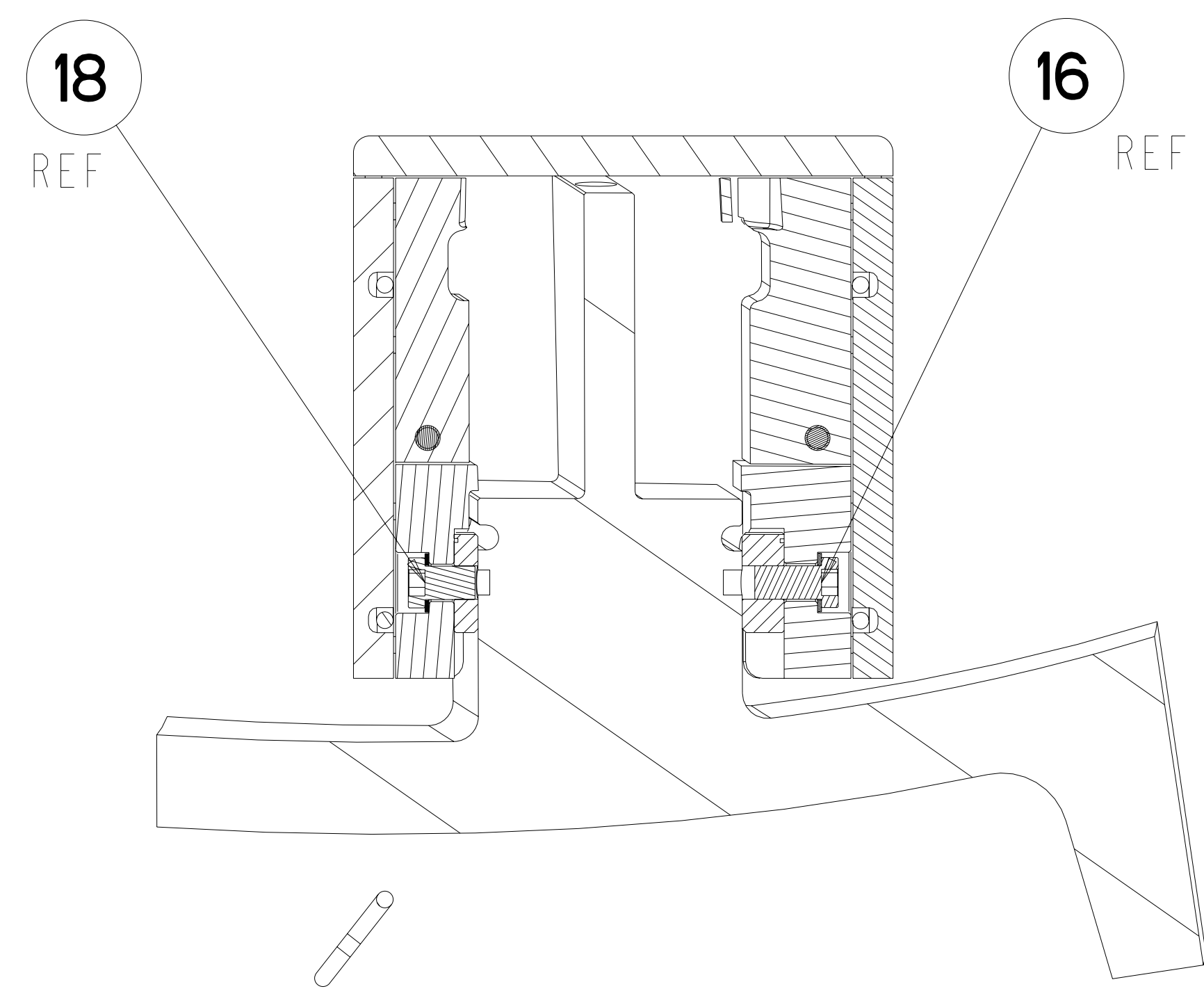

SECTION B-B

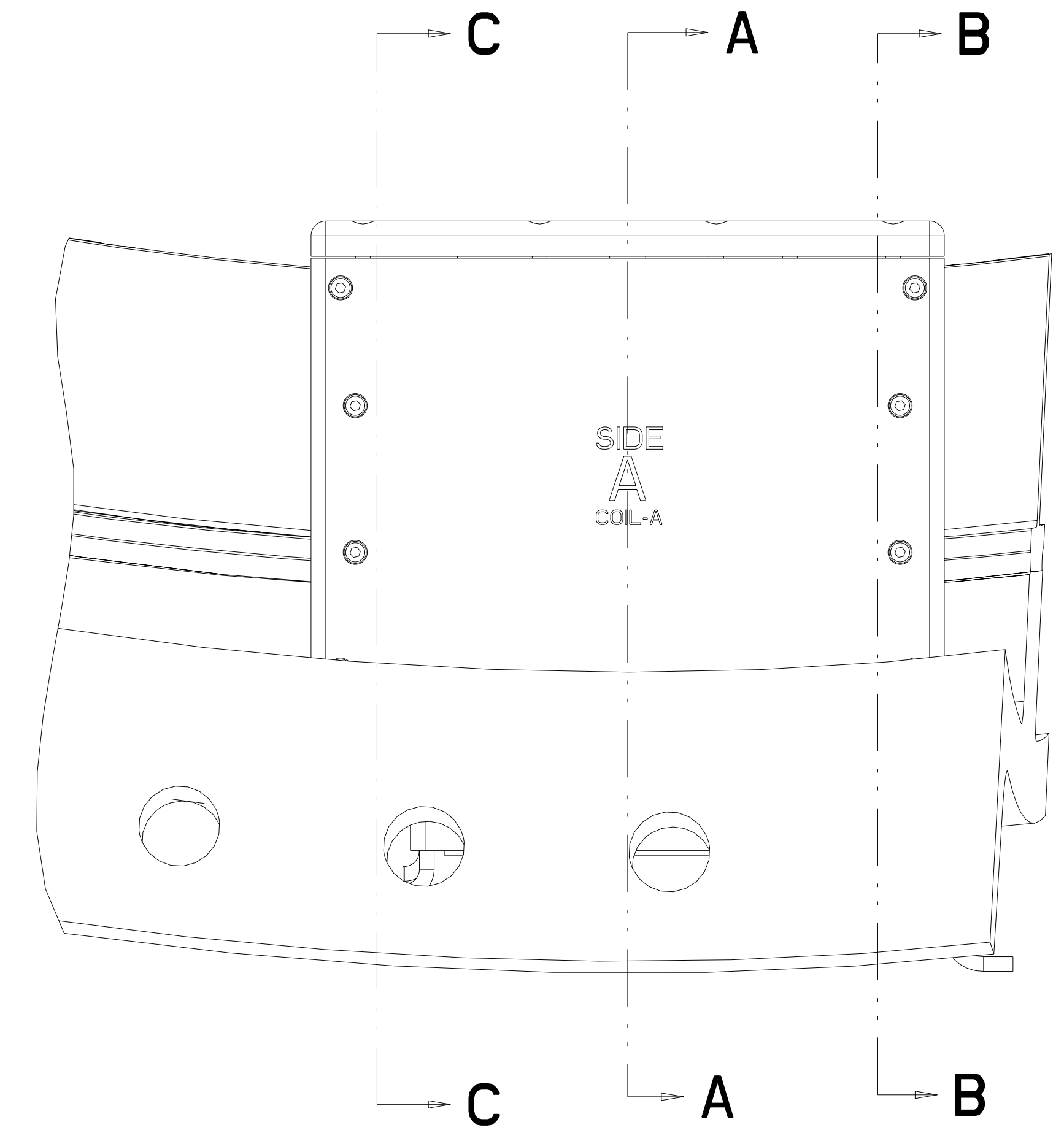

SIDE VIEW
SCALE 0.50

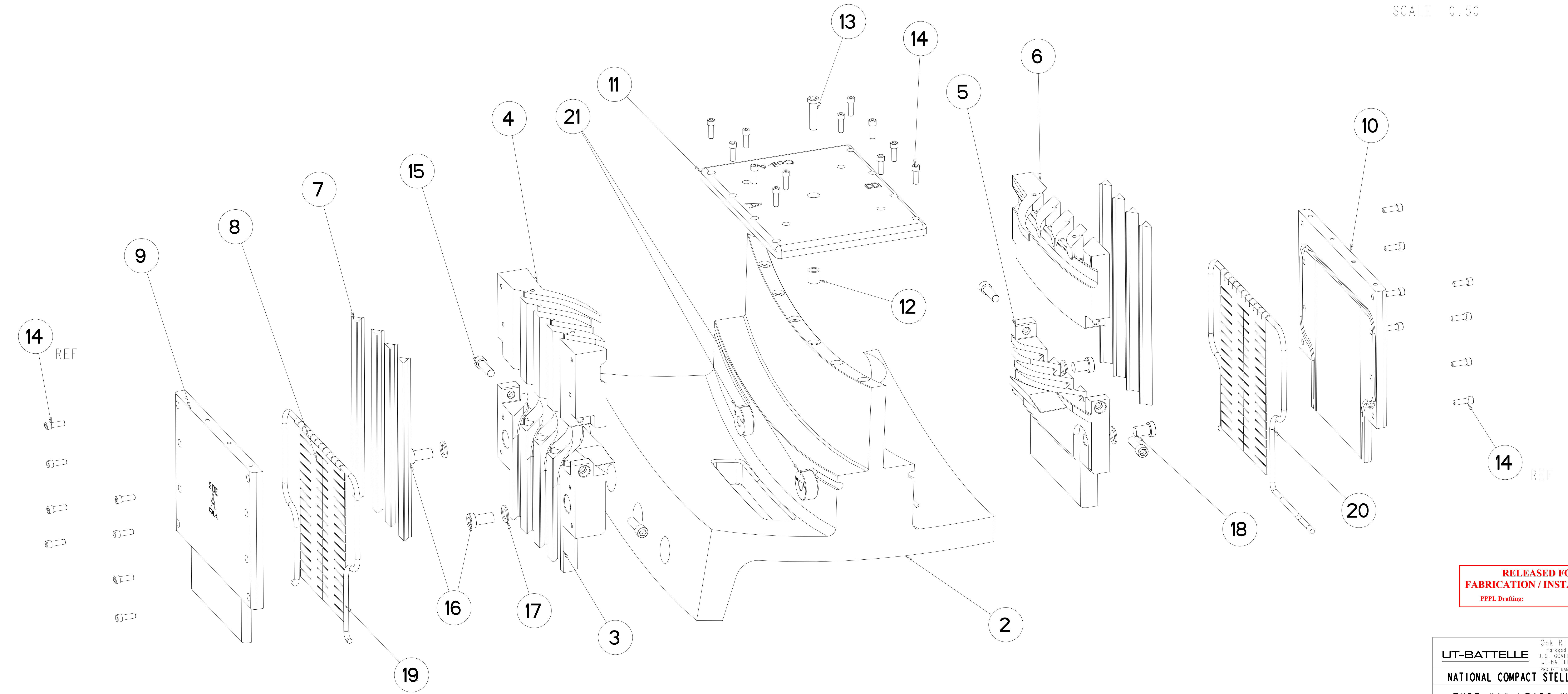

EXPLODED VIEW

SCALE 0.50

**RELEASED FOR
FABRICATION / INSTALLATION**
 PPPL Drafting

Oak Ridge National Laboratory managed for the DEPARTMENT OF ENERGY under U.S. GOVERNMENT CONTRACT DE-AC05-00OR22725 UT-BATTELLE, LLC, Oak Ridge, Tennessee PROJECT NAME									
NATIONAL COMPACT STELLARATOR EXPERIMENT									
TYPE "A" LEADS WINDING BLOCKS ASSEMBLY									
VERSION NO.	PLANT	BLDG	FL	SHT	OF	TYPE	CLASS		
25	X-10	5700	3	2	2	S	U		
RELEASE LEVEL		SE 142A-080						REV	
Fabrication								0	

8

7

6

5

4

3

2

1