

- NOTES:
1. INTERPRET DIMENSIONS AND TOLERANCES PER ANSI Y14.5M
  2. DIMENSIONS ARE IN INCHES
  3. DIMENSIONS APPLY AT ROOM TEMPERATURE. OPERATING TEMP 80 K.
  4. GEOMETRY IS DEFINED IN PRO ENGINEER CAD MODELS/FILES SEI406-137.PRT
  5. DRAWING AND MODELS COMBINED DEFINE FINISHED MACHINED PART.

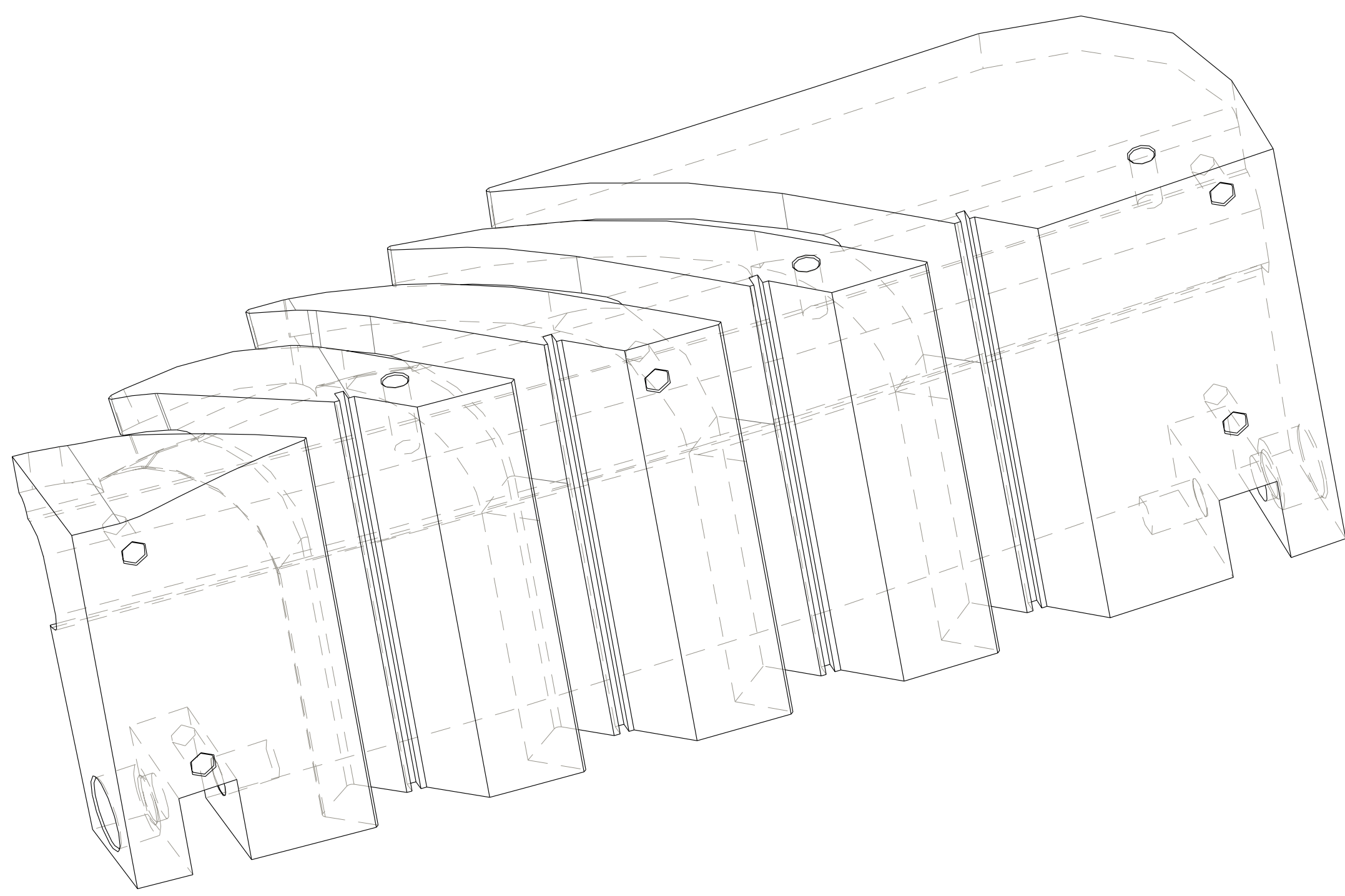

ISOMETRIC VIEW

**ECN-5066.** This ECN Revised winding pack and conductor dimensions to match as-built Twisted Racetrack Coil (TRC) measurements. The first involved a very slight increase in the large radius (by sanding) in zone G-6 to provide additional winding pack clearance. In Zone D-4, a groove was added to the end of the block for the purpose of routing the flux loop diagnostic.  
 (See ECN-5066 for details)

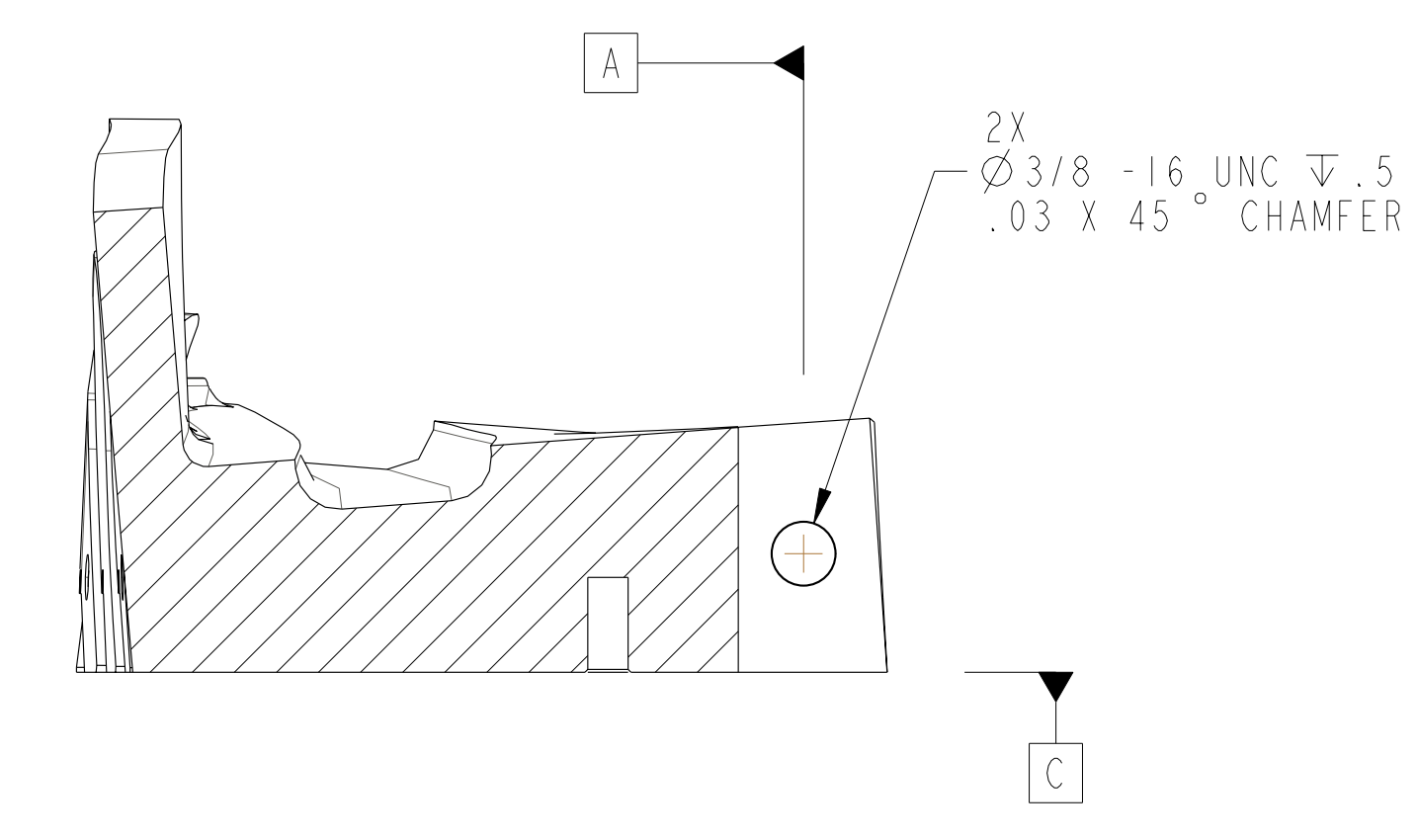
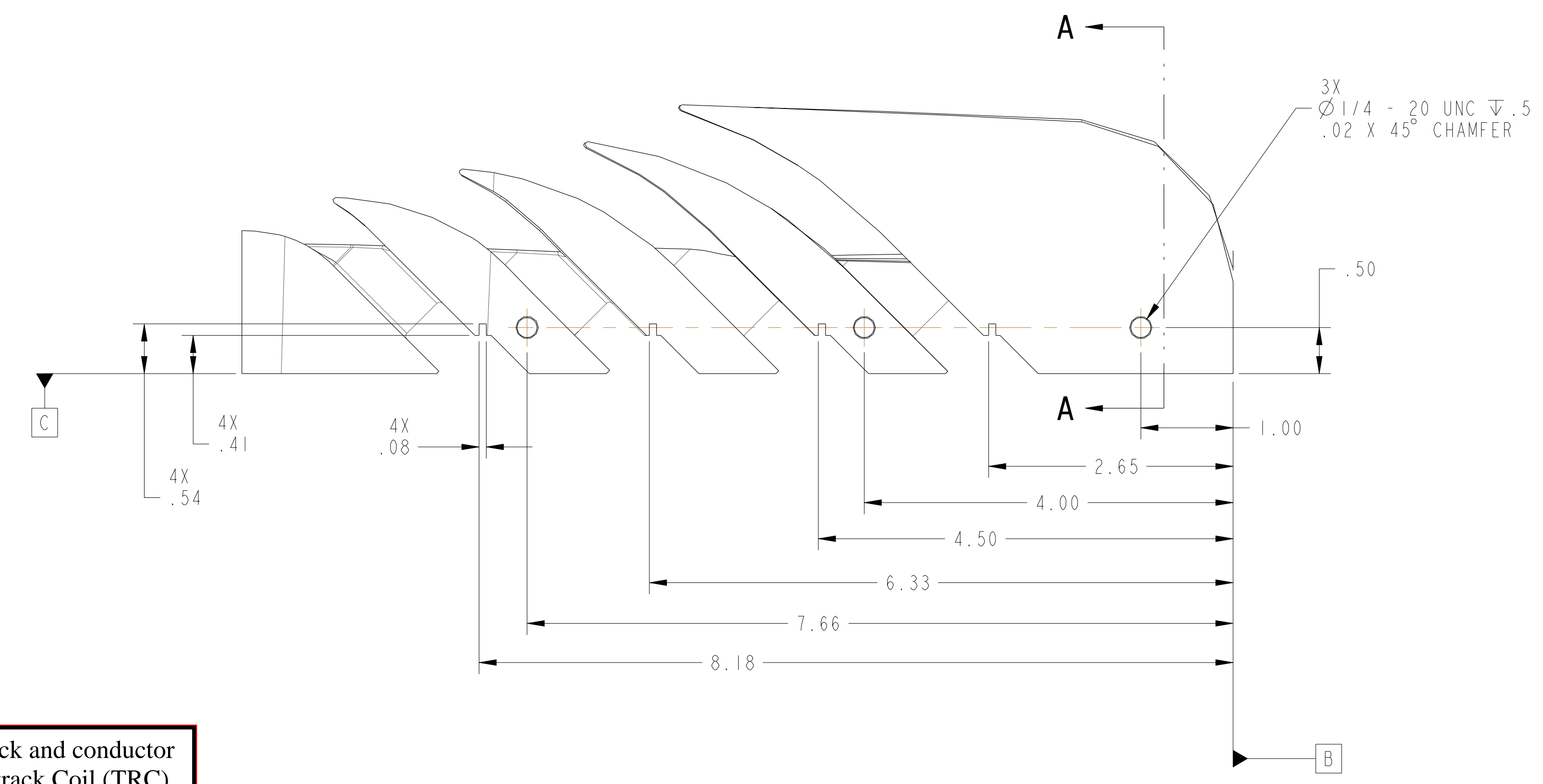

SECTION A-A

**RELEASED FOR FABRICATION / INSTALLATION**  
 PPPL Drafting:

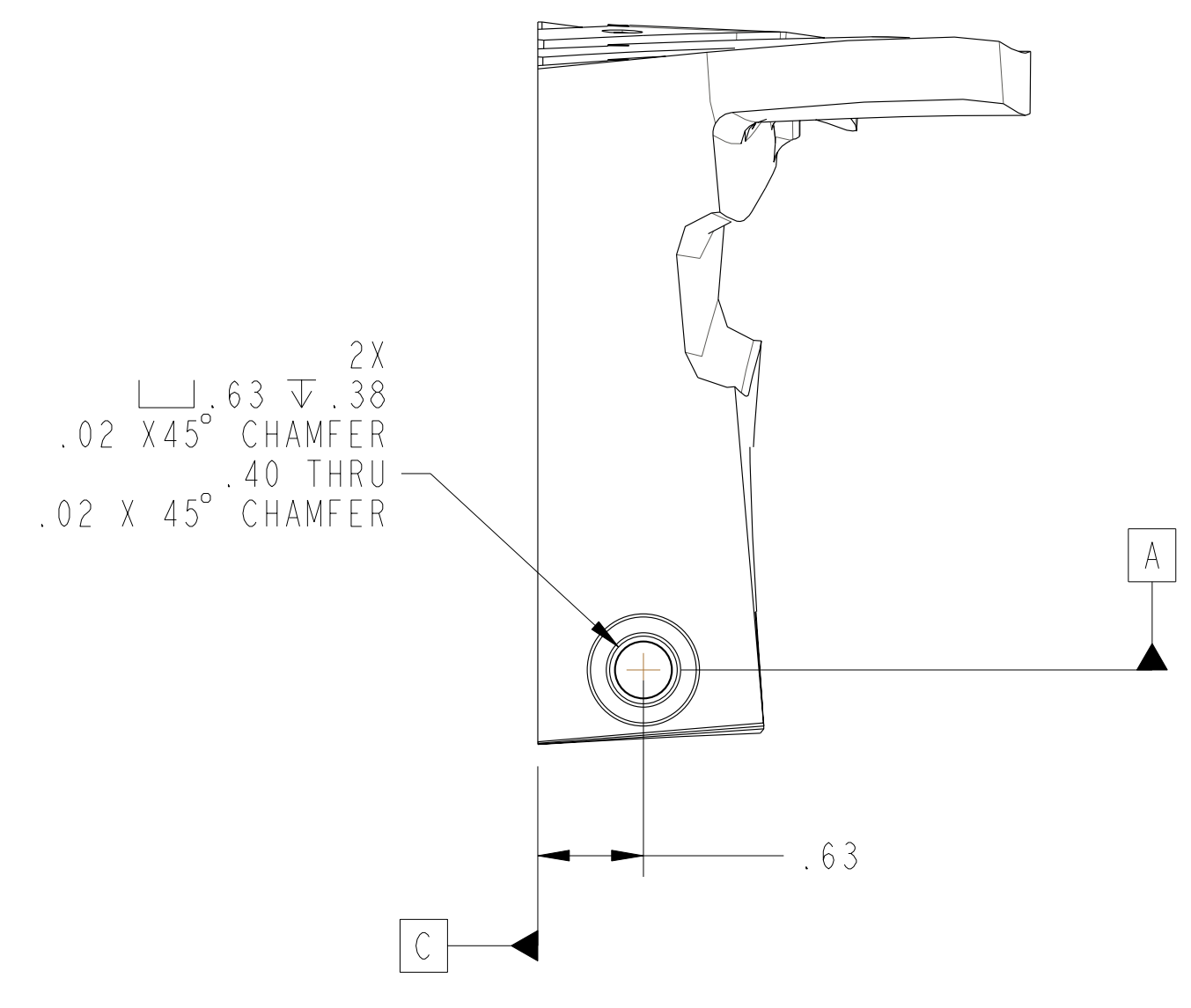
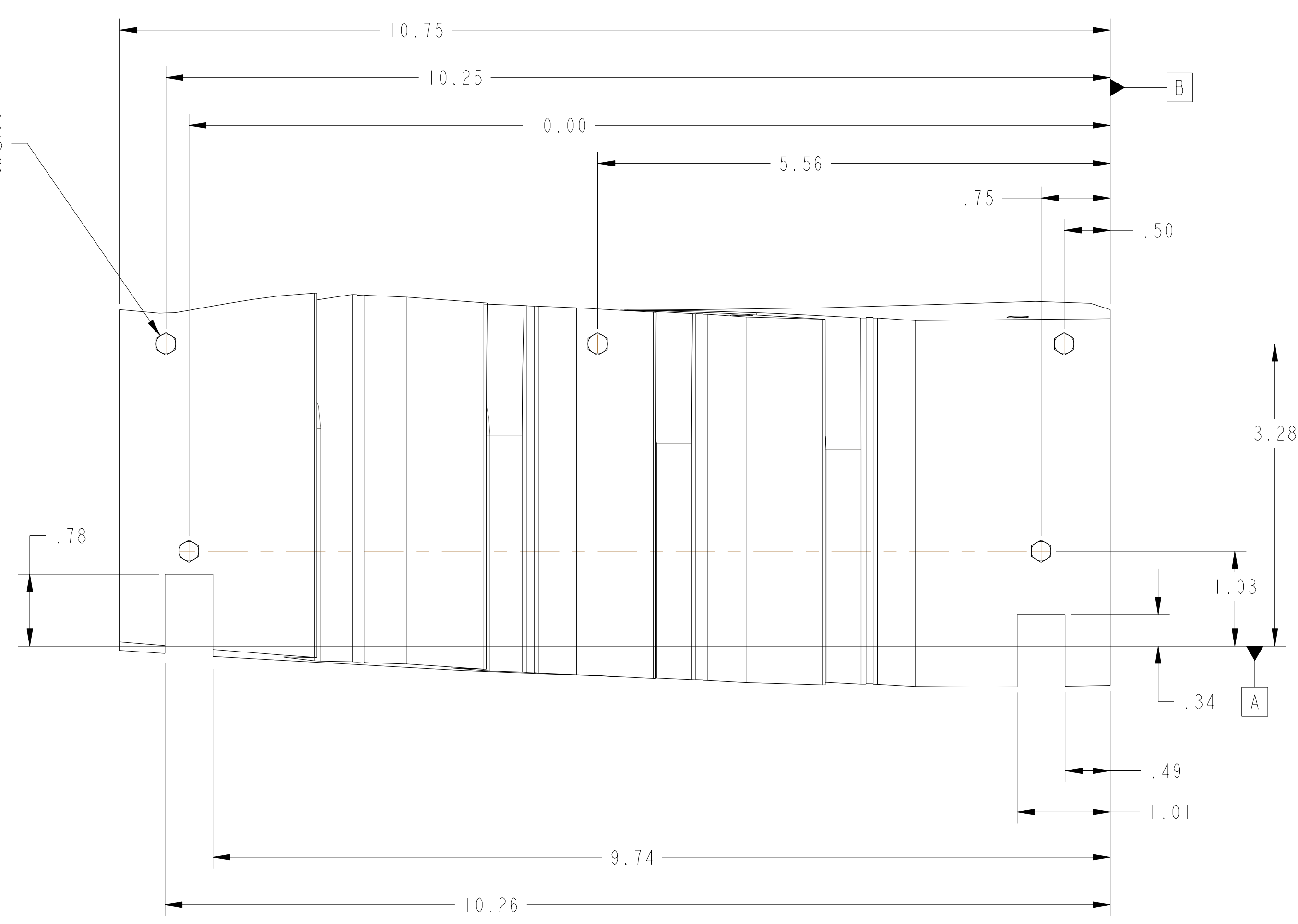
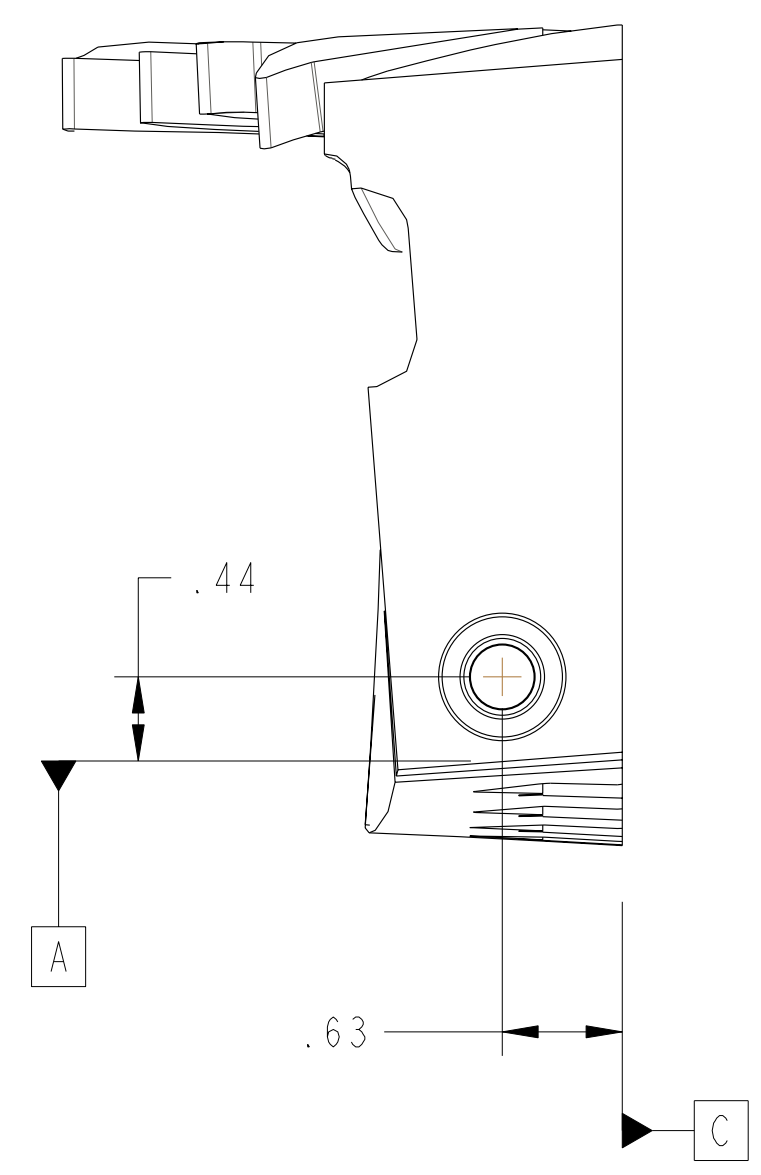
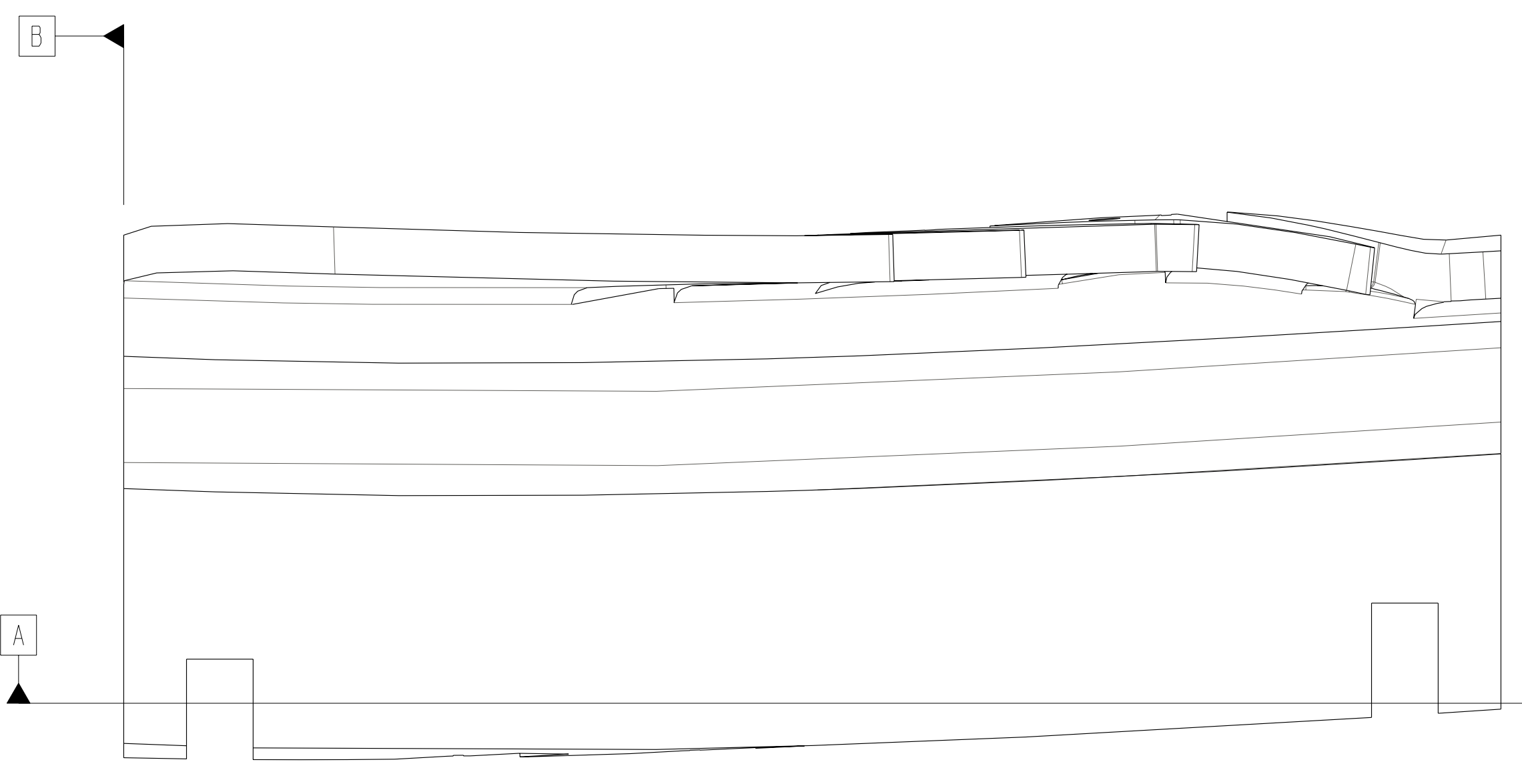

1  
 SCALE 1 : 1

next assy	CAGE CODE	PART OR IDENTIFYING NO	UPPER "B" FILL BLOCK NOMENCLATURE OR DESCRIPTION	GII MATERIAL	SPECIFICATION	FIND NO

← NEXT ASSEMBLY PARTS LIST

NO REPRESENTATION OR WARRANTY, EXPRESSED OR IMPLIED, IS MADE AS TO THE ACCURACY, COMPLETENESS OR USEFULNESS OF THE INFORMATION OR STATEMENTS CONTAINED IN THESE DRAWINGS, OR THAT THE USE OR DISCLOSURE OF ANY INFORMATION, APPARATUS, METHOD OR PROCESS DISCLOSED IN THESE DRAWINGS MAY NOT INFRINGE PRIVATE RIGHTS OF OTHERS. NO LIABILITY IS ASSUMED WITH RESPECT TO THE USE OF, OR FOR DAMAGES RESULTING FROM THE USE OF, ANY INFORMATION, APPARATUS, METHOD OR PROCESS DISCLOSED IN THESE DRAWINGS. DRAWINGS MADE AVAILABLE FOR INFORMATION TO BIDDER ARE NOT TO BE USED FOR OTHER PURPOSES, AND ARE TO BE RETURNED UPON REQUEST OF THE FORWARDING CONTRACTOR.

**P** THIS DRAWING PRODUCED ON PRO-ENGINEER

REV	DESCRIPTION	BY	DATE	CHK	DEPT	DATE	PE	REQ	DATE	ORNL	DOE	DATE
0	INITIAL RELEASE	GLL	6-05		DEW							

SCALE NOTED	DES: PJ FOGARTY 6-05	<b>UT-BATTELLE</b> Oak Ridge National Laboratory managed for the DEPARTMENT OF ENERGY under U.S. GOVERNMENT contract DE-AC05-00OR22725 UT-BATTELLE, LLC, Oak Ridge, Tennessee PROJECT NAME: NATIONAL COMPACT STELLARATOR EXPERIMENT
TOLERANCES UNLESS OTHERWISE SPECIFIED	DRW: G LOVETT 6-05	
FRACTIONS	CHK: M COLE 6-05	
XX DECIMALS ±.01	SECT: :	
XXX DECIMALS ±.005	DEPT: :	UPPER LEAD BLOCK SIDE "B"
ANGLES ±0°15'	PE: D WILLIAMSON 6-05	
BREAK SHARP EDGES .06 MAX	CR: :	
FINISH .125 UNLESS OTHERWISE SPECIFIED	PJ: :	
	REQ: :	VERSION NO. 4 PLANT X-10 BLDG 5700 FL 3 SHT 1 OF 1 TYPE U CLASS U REV 0
	PPPL DRFT J SIEGEL 6-05	RELEASE LEVEL Fabrication SEI42C-137
	DRAWING APPROVALS	