

INSTANCE NAME	HOLE	S-DIM	PART NAME
SEI42C-384-FLAT-270		0.885417	SEI42C-384-270
SEI42C-384-FLAT-271	1	0.890625	SEI42C-384-271
SEI42C-384-FLAT-272		0.895833	SEI42C-384-272
SEI42C-384-FLAT-273	2	0.901042	SEI42C-384-273
SEI42C-384-FLAT-274		0.906250	SEI42C-384-274
SEI42C-384-FLAT-275	3	0.911458	SEI42C-384-275
SEI42C-384-FLAT-276		0.916667	SEI42C-384-276
SEI42C-384-FLAT-277	4	0.921875	SEI42C-384-277
SEI42C-384-FLAT-278		0.927083	SEI42C-384-278
SEI42C-384-FLAT-279	5	0.932292	SEI42C-384-279
SEI42C-384-FLAT-280		0.937500	SEI42C-384-280
SEI42C-384-FLAT-281	6	0.942708	SEI42C-384-281
SEI42C-384-FLAT-282		0.947917	SEI42C-384-282
SEI42C-384-FLAT-283	7	0.953125	SEI42C-384-283
SEI42C-384-FLAT-284		0.958333	SEI42C-384-284
SEI42C-384-FLAT-285	8	0.963542	SEI42C-384-285
SEI42C-384-FLAT-286		0.968750	SEI42C-384-286
SEI42C-384-FLAT-287	9	0.973958	SEI42C-384-287
SEI42C-384-FLAT-288		0.979167	SEI42C-384-288
SEI42C-384-FLAT-289	10	0.984375	SEI42C-384-289
SEI42C-384-FLAT-290		0.989583	SEI42C-384-290
SEI42C-384-FLAT-291	11	0.994792	SEI42C-384-291
SEI42C-384-FLAT-290-NEW		0.000000	SEI42C-384-290
SEI42C-384-FLAT-101	12	0.005208	SEI42C-384-101
SEI42C-384-FLAT-102		0.010417	SEI42C-384-102
SEI42C-384-FLAT-103-NEW	13	0.015625	SEI42C-384-103
SEI42C-384-FLAT-NEW-104		0.019341	SEI42C-384-104
SEI42C-384-FLAT-105	14	0.024000	SEI42C-384-105
SEI42C-384-FLAT-NEW-106		0.024579	SEI42C-384-106
SEI42C-384-FLAT-NEW-107	15	0.036000	SEI42C-384-107
SEI42C-384-FLAT-107-108		0.041000	SEI42C-384-108
SEI42C-384-FLAT-109	16	0.046875	SEI42C-384-109
SEI42C-384-FLAT-110		0.052083	SEI42C-384-110
SEI42C-384-FLAT-111	17	0.057292	SEI42C-384-111
SEI42C-384-FLAT-112		0.062500	SEI42C-384-112
SEI42C-384-FLAT-113	18	0.067708	SEI42C-384-113
SEI42C-384-FLAT-114		0.072917	SEI42C-384-114
SEI42C-384-FLAT-115	19	0.078125	SEI42C-384-115
SEI42C-384-FLAT-116		0.083333	SEI42C-384-116
SEI42C-384-FLAT-117	20	0.088542	SEI42C-384-117
SEI42C-384-FLAT-118		0.093750	SEI42C-384-118
SEI42C-384-FLAT-119	21	0.098958	SEI42C-384-119
SEI42C-384-FLAT-120		0.104167	SEI42C-384-120
SEI42C-384-FLAT-121	22	0.109375	SEI42C-384-121
SEI42C-384-FLAT-122		0.114583	SEI42C-384-122
SEI42C-384-FLAT-123	23	0.119792	SEI42C-384-123
SEI42C-384-FLAT-124		0.125000	SEI42C-384-124
SEI42C-384-FLAT-125	24	0.130208	SEI42C-384-125
SEI42C-384-FLAT-126		0.135417	SEI42C-384-126
SEI42C-384-FLAT-127	25	0.140625	SEI42C-384-127
SEI42C-384-FLAT-128		0.145833	SEI42C-384-128
SEI42C-384-FLAT-129	26	0.151042	SEI42C-384-129
SEI42C-384-FLAT-130		0.156250	SEI42C-384-130
SEI42C-384-FLAT-131	27	0.161458	SEI42C-384-131
SEI42C-384-FLAT-132		0.166667	SEI42C-384-132
SEI42C-384-FLAT-133	28	0.171875	SEI42C-384-133
SEI42C-384-FLAT-134		0.177083	SEI42C-384-134
SEI42C-384-FLAT-135	29	0.182292	SEI42C-384-135
SEI42C-384-FLAT-136		0.187500	SEI42C-384-136
SEI42C-384-FLAT-137	30	0.192708	SEI42C-384-137
SEI42C-384-FLAT-138		0.197917	SEI42C-384-138
SEI42C-384-FLAT-139	31	0.203125	SEI42C-384-139
SEI42C-384-FLAT-140		0.208333	SEI42C-384-140
SEI42C-384-FLAT-141	32	0.213542	SEI42C-384-141
SEI42C-384-FLAT-142		0.218750	SEI42C-384-142
SEI42C-384-FLAT-143	33	0.223958	SEI42C-384-143
SEI42C-384-FLAT-144		0.229167	SEI42C-384-144
SEI42C-384-FLAT-145	34	0.234375	SEI42C-384-145
SEI42C-384-FLAT-146		0.239583	SEI42C-384-146
SEI42C-384-FLAT-147	35	0.244792	SEI42C-384-147
SEI42C-384-FLAT-148		0.250000	SEI42C-384-148
SEI42C-384-FLAT-149	36	0.255208	SEI42C-384-149
SEI42C-384-FLAT-150		0.260417	SEI42C-384-150
SEI42C-384-FLAT-151	37	0.265625	SEI42C-384-151
SEI42C-384-FLAT-152		0.270833	SEI42C-384-152
SEI42C-384-FLAT-153	38	0.276042	SEI42C-384-153
SEI42C-384-FLAT-154		0.281250	SEI42C-384-154
SEI42C-384-FLAT-155	39	0.286458	SEI42C-384-155
SEI42C-384-FLAT-156		0.291667	SEI42C-384-156
SEI42C-384-FLAT-157	40	0.296875	SEI42C-384-157
SEI42C-384-FLAT-158		0.302083	SEI42C-384-158
SEI42C-384-FLAT-159	41	0.307292	SEI42C-384-159
SEI42C-384-FLAT-160		0.312500	SEI42C-384-160
SEI42C-384-FLAT-161	42	0.317708	SEI42C-384-161
SEI42C-384-FLAT-162		0.322917	SEI42C-384-162
SEI42C-384-FLAT-163	43	0.328125	SEI42C-384-163
SEI42C-384-FLAT-164		0.333333	SEI42C-384-164
SEI42C-384-FLAT-165	44	0.338542	SEI42C-384-165
SEI42C-384-FLAT-166		0.343750	SEI42C-384-166
SEI42C-384-FLAT-167	45	0.348958	SEI42C-384-167
SEI42C-384-FLAT-168		0.354167	SEI42C-384-168
SEI42C-384-FLAT-169	46	0.359375	SEI42C-384-169
SEI42C-384-FLAT-170		0.364583	SEI42C-384-170
SEI42C-384-FLAT-171	47	0.369792	SEI42C-384-171
SEI42C-384-FLAT-172		0.375000	SEI42C-384-172
SEI42C-384-FLAT-173	48	0.380208	SEI42C-384-173

INSTANCE NAME	HOLE	S-DIM	PART NAME
SEI42C-384-FLAT-174		0.385417	SEI42C-384-174
SEI42C-384-FLAT-175	49	0.390625	SEI42C-384-175
SEI42C-384-FLAT-176		0.395833	SEI42C-384-176
SEI42C-384-FLAT-177	50	0.401042	SEI42C-384-177
SEI42C-384-FLAT-178		0.406250	SEI42C-384-178
SEI42C-384-FLAT-179	51	0.411458	SEI42C-384-179
SEI42C-384-FLAT-180		0.416667	SEI42C-384-180
SEI42C-384-FLAT-181	52	0.421875	SEI42C-384-181
SEI42C-384-FLAT-182		0.427083	SEI42C-384-182
SEI42C-384-FLAT-183	53	0.432292	SEI42C-384-183
SEI42C-384-FLAT-184		0.437500	SEI42C-384-184
SEI42C-384-FLAT-185	54	0.442708	SEI42C-384-185
SEI42C-384-FLAT-186		0.447917	SEI42C-384-186
SEI42C-384-FLAT-187	55	0.453125	SEI42C-384-187
SEI42C-384-FLAT-188		0.458333	SEI42C-384-188
SEI42C-384-FLAT-189	56	0.463542	SEI42C-384-189
SEI42C-384-FLAT-190		0.468750	SEI42C-384-190
SEI42C-384-FLAT-191	57	0.473958	SEI42C-384-191
SEI42C-384-FLAT-192		0.479167	SEI42C-384-192
SEI42C-384-FLAT-193	58	0.484375	SEI42C-384-193
SEI42C-384-FLAT-194		0.489583	SEI42C-384-194
SEI42C-384-FLAT-195-NEW	59	0.494792	SEI42C-384-195
SEI42C-384-FLAT-196		0.500000	SEI42C-384-196
SEI42C-384-FLAT-197	60	0.505208	SEI42C-384-197
SEI42C-384-FLAT-198		0.510417	SEI42C-384-198
SEI42C-384-FLAT-199	61	0.515625	SEI42C-384-199
SEI42C-384-FLAT-198		0.520833	SEI42C-384-200
SEI42C-384-FLAT-201	62	0.526042	SEI42C-384-201
SEI42C-384-FLAT-202		0.531250	SEI42C-384-202
SEI42C-384-FLAT-203	63	0.536458	SEI42C-384-203
SEI42C-384-FLAT-204		0.541667	SEI42C-384-204
SEI42C-384-FLAT-205	64	0.546875	SEI42C-384-205
SEI42C-384-FLAT-206		0.552083	SEI42C-384-206
SEI42C-384-FLAT-207	65	0.557292	SEI42C-384-207
SEI42C-384-FLAT-208		0.562500	SEI42C-384-208
SEI42C-384-FLAT-209	66	0.567708	SEI42C-384-209
SEI42C-384-FLAT-210		0.572917	SEI42C-384-210
SEI42C-384-FLAT-211	67	0.578125	SEI42C-384-211
SEI42C-384-FLAT-212		0.583333	SEI42C-384-212
SEI42C-384-FLAT-213	68	0.588542	SEI42C-384-213
SEI42C-384-FLAT-214		0.593750	SEI42C-384-214
SEI42C-384-FLAT-215	69	0.598959	SEI42C-384-215
SEI42C-384-FLAT-216		0.604167	SEI42C-384-216
SEI42C-384-FLAT-217	70	0.609375	SEI42C-384-217
SEI42C-384-FLAT-218		0.614584	SEI42C-384-218
SEI42C-384-FLAT-219	71	0.619792	SEI42C-384-219
SEI42C-384-FLAT-220		0.625000	SEI42C-384-220
SEI42C-384-FLAT-221	72	0.630209	SEI42C-384-221
SEI42C-384-FLAT-222		0.635417	SEI42C-384-222
SEI42C-384-FLAT-223	73	0.640625	SEI42C-384-223
SEI42C-384-FLAT-224		0.645834	SEI42C-384-224
SEI42C-384-FLAT-225	74	0.651042	SEI42C-384-225
SEI42C-384-FLAT-226		0.656250	SEI42C-384-226
SEI42C-384-FLAT-227	75	0.661458	SEI42C-384-227
SEI42C-384-FLAT-228		0.666667	SEI42C-384-228
SEI42C-384-FLAT-229	76	0.671875	SEI42C-384-229
SEI42C-384-FLAT-230		0.677083	SEI42C-384-230
SEI42C-384-FLAT-231	77	0.682292	SEI42C-384-231
SEI42C-384-FLAT-232		0.687500	SEI42C-384-232
SEI42C-384-FLAT-233	78	0.692708	SEI42C-384-233
SEI42C-384-FLAT-234		0.697917	SEI42C-384-234
SEI42C-384-FLAT-235	79	0.703125	SEI42C-384-235
SEI42C-384-FLAT-236		0.708333	SEI42C-384-236
SEI42C-384-FLAT-237	80	0.713542	SEI42C-384-237
SEI42C-384-FLAT-238		0.718750	SEI42C-384-238
SEI42C-384-FLAT-239	81	0.723958	SEI42C-384-239
SEI42C-384-FLAT-240		0.729167	SEI42C-384-240
SEI42C-384-FLAT-241	82	0.734375	SEI42C-384-241
SEI42C-384-FLAT-242		0.739583	SEI42C-384-242
SEI42C-384-FLAT-243	83	0.744792	SEI42C-384-243
SEI42C-384-FLAT-244		0.750000	SEI42C-384-244
SEI42C-384-FLAT-245	84	0.755208	SEI42C-384-245
SEI42C-384-FLAT-246		0.760417	SEI42C-384-246
SEI42C-384-FLAT-247	85	0.765625	SEI42C-384-247
SEI42C-384-FLAT-248		0.770833	SEI42C-384-248
SEI42C-384-FLAT-249	86	0.776042	SEI42C-384-249
SEI42C-384-FLAT-250		0.781250	SEI42C-384-250
SEI42C-384-FLAT-NEW-251	87	0.786458	SEI42C-384-251
SEI42C-384-FLAT-NEW-252		0.791667	SEI42C-384-252
SEI42C-384-FLAT-NEW-253	88	0.796875	SEI42C-384-253
SEI42C-384-FLAT-NEW-254		0.802083	SEI42C-384-254
SEI42C-384-FLAT-NEW-255	89	0.807292	SEI42C-384-255
SEI42C-384-FLAT-NEW-256		0.812500	SEI42C-384-256
SEI42C-384-FLAT-NEW-257	90	0.817708	SEI42C-384-257
SEI42C-384-FLAT-NEW-258		0.822917	SEI42C-384-258
SEI42C-384-FLAT-NEW-259	91	0.828125	SEI42C-384-259
SEI42C-384-FLAT-260		0.833333	SEI42C-384-260
SEI42C-384-FLAT-261	92	0.838542	SEI42C-384-261
SEI42C-384-FLAT-262		0.843750	SEI42C-384-262
SEI42C-384-FLAT-263	93	0.848958	SEI42C-384-263
SEI42C-384-FLAT-264		0.854167	SEI42C-384-264
SEI42C-384-FLAT-265	94	0.859375	SEI42C-384-265
SEI42C-384-FLAT-266		0.864583	SEI42C-384-266
SEI42C-384-FLAT-267	95	0.869792	SEI42C-384-267
SEI42C-384-FLAT-268		0.875000	SEI42C-384-268
SEI42C-384-FLAT-269	96	0.880208	SEI42C-384-269

- NOTES
- DRAWING PREPARED IN ACCORDANCE WITH ASME Y14.8M-1996.
 - INTERPRET DIMENSIONS AND TOLERANCES PER ANSI Y14.5M-1994.
 - DIMENSIONS ARE IN INCHES.
 - DRAWING DEPICTS FLAT PATTERN OF FORMED PARTS DEFINED BY PRO/ENGINEER FILES SEI42C-384-XXX-FORM.PRT.
 - PROFILE TOLERANCE OF FLAT PATTERN IS +/- .010 IN.</

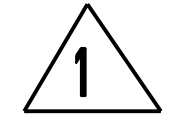

THESE PARTS TO BE NEMA GRADE GIICR MATERIAL

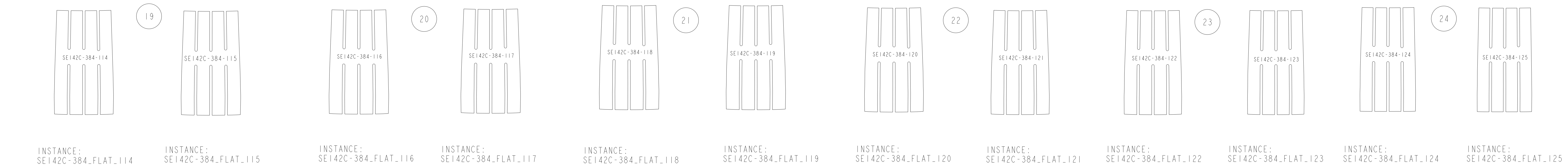
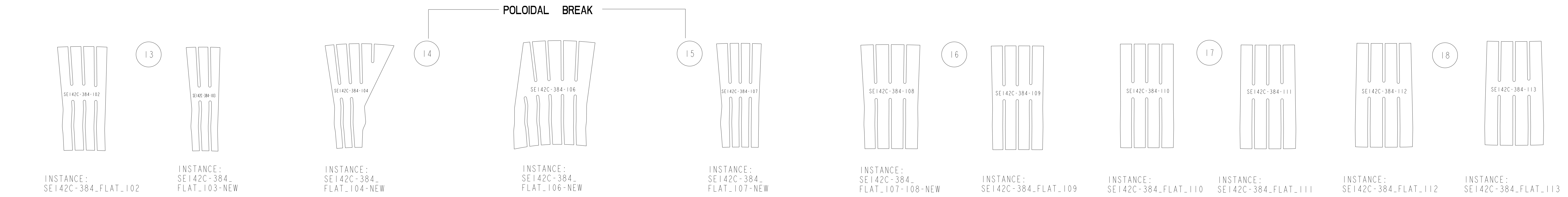
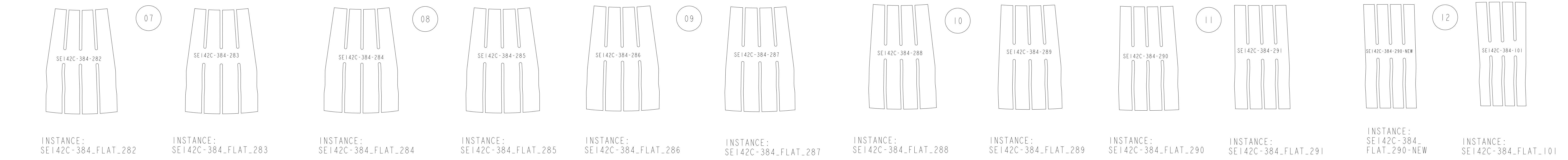
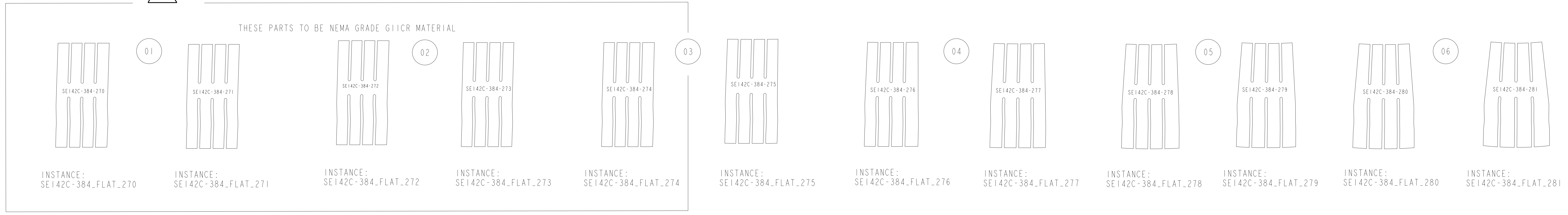

SCALE ALL VIEWS: 1.00

RELEASED FOR FABRICATION / INSTALLATION
 PPPL Drafting:

UT-BATTELLE										Oak Ridge National Laboratory managed for the DEPARTMENT OF ENERGY under U.S. GOVERNMENT CONTRACT DE-AC05-00OR22725 UT-BATTELLE, LLC - Oak Ridge, Tennessee									
PROJECT NAME										NATIONAL COMPACT STELLARATOR EXPERIMENT									
MODULAR COIL TYPE - C										SIDE - A LOWER CLADDING									
FLAT PATTERN LAYOUT																			
VERSION NO.	PLANT	BLDG	FL	SHT	OF	TYPE	CLASS												
4	X-10	5700	3	2	5	S	U												
RELEASE LEVEL		SEI42C-384								REV		REV		REV		REV			
Fabrication																			

SEI42C-384

8

7

6

5

4

3

2

1

NEXT ASS'Y:

FINAL ASS'Y:

H

H

G

G

F

F

E

E

D

D

C

C

B

B

A

A

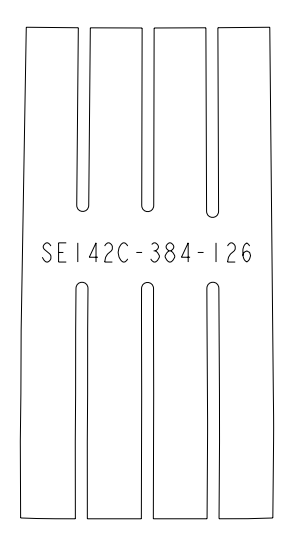

25

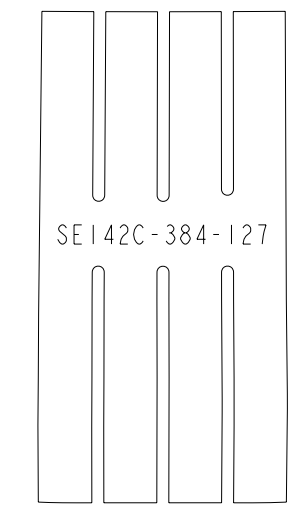

26

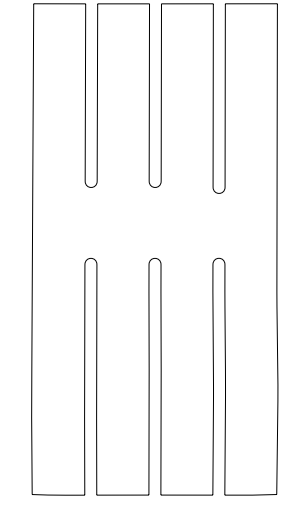

27

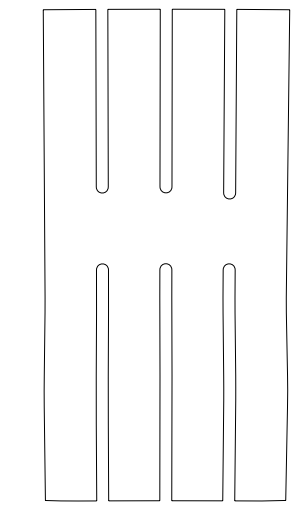

28

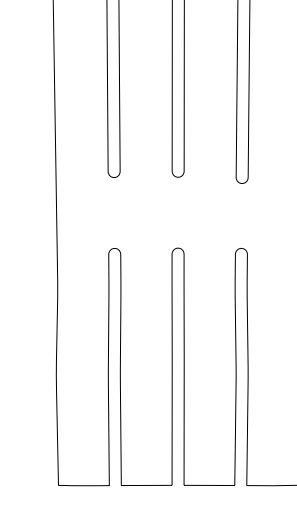

29

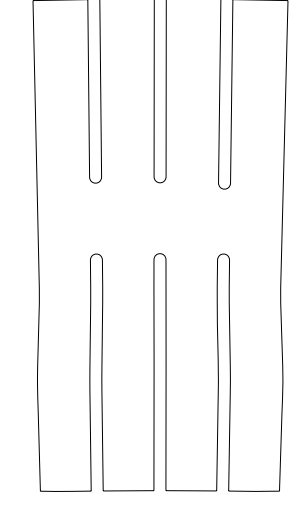

30

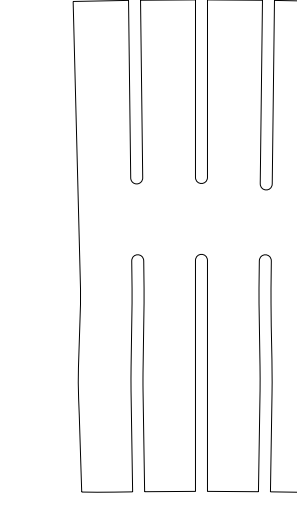

INSTANCE:
SE142C-384_FLAT_126

INSTANCE:
SE142C-384_FLAT_127

INSTANCE:
SE142C-384_FLAT_128

INSTANCE:
SE142C-384_FLAT_129

INSTANCE:
SE142C-384_FLAT_130

INSTANCE:
SE142C-384_FLAT_131

INSTANCE:
SE142C-384_FLAT_132

INSTANCE:
SE142C-384_FLAT_133

INSTANCE:
SE142C-384_FLAT_134

INSTANCE:
SE142C-384_FLAT_135

INSTANCE:
SE142C-384_FLAT_136

INSTANCE:
SE142C-384_FLAT_137

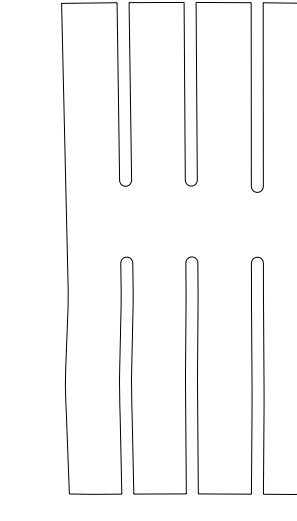

31

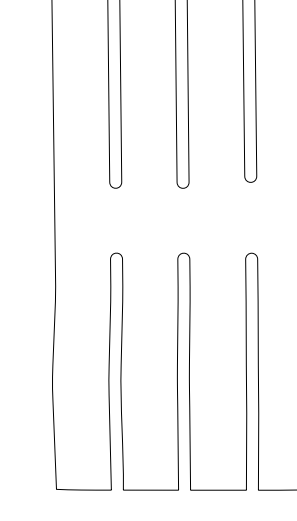

32

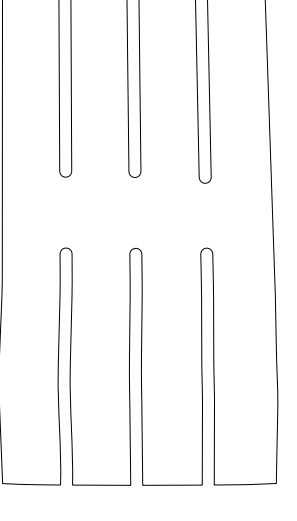

33

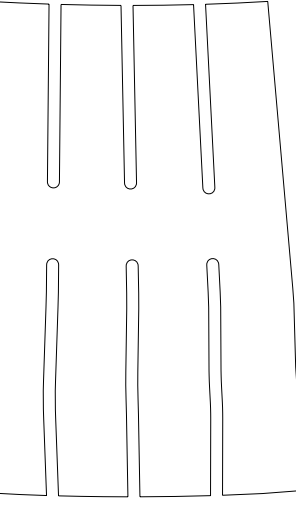

34

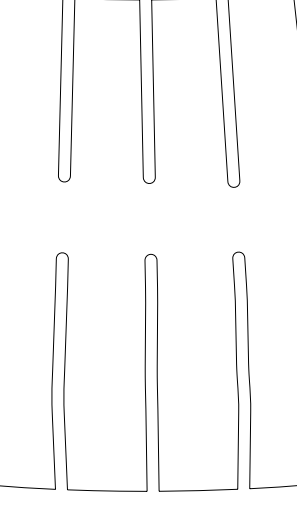

35

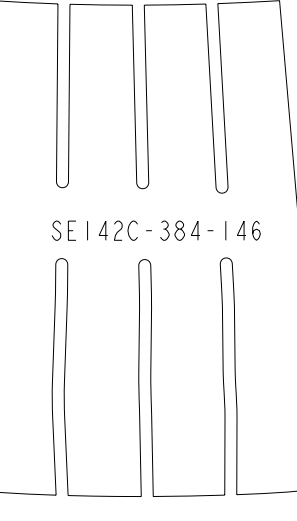

36

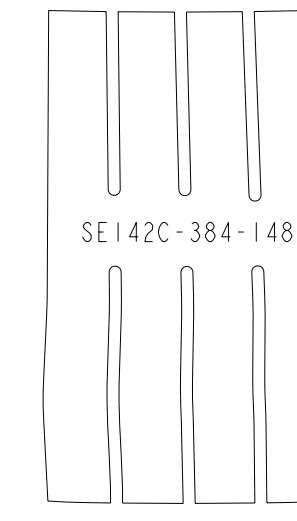

INSTANCE:
SE142C-384_FLAT_138

INSTANCE:
SE142C-384_FLAT_139

INSTANCE:
SE142C-384_FLAT_140

INSTANCE:
SE142C-384_FLAT_141

INSTANCE:
SE142C-384_FLAT_142

INSTANCE:
SE142C-384_FLAT_143

INSTANCE:
SE142C-384_FLAT_144

INSTANCE:
SE142C-384_FLAT_145

INSTANCE:
SE142C-384_FLAT_146

INSTANCE:
SE142C-384_FLAT_147

INSTANCE:
SE142C-384_FLAT_148

INSTANCE:
SE142C-384_FLAT_149

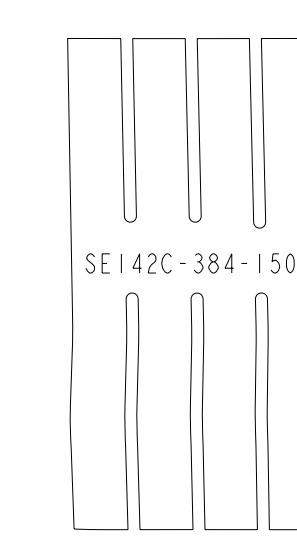

37

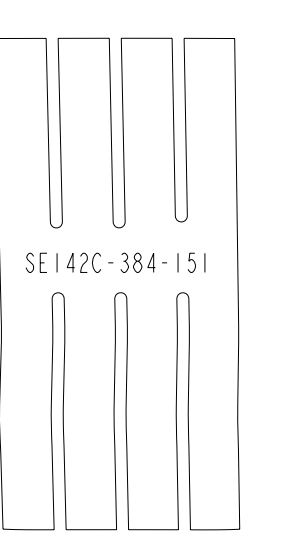

38

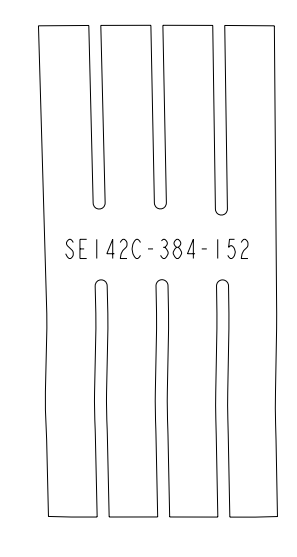

39

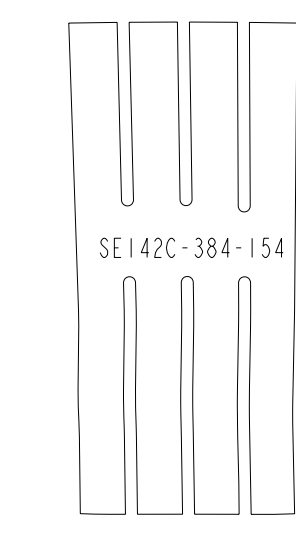

40

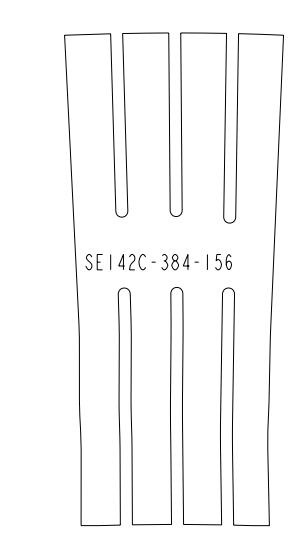

41

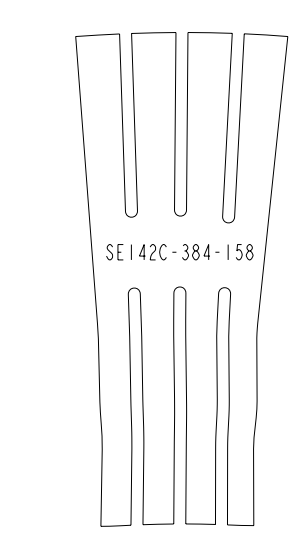

42

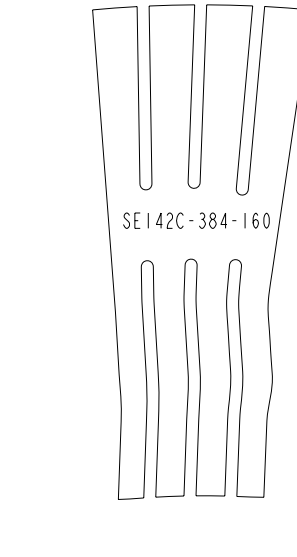

INSTANCE:
SE142C-384_FLAT_150

INSTANCE:
SE142C-384_FLAT_151

INSTANCE:
SE142C-384_FLAT_152

INSTANCE:
SE142C-384_FLAT_153

INSTANCE:
SE142C-384_FLAT_154

INSTANCE:
SE142C-384_FLAT_155

INSTANCE:
SE142C-384_FLAT_156

INSTANCE:
SE142C-384_FLAT_157

INSTANCE:
SE142C-384_FLAT_158

INSTANCE:
SE142C-384_FLAT_159

INSTANCE:
SE142C-384_FLAT_160

INSTANCE:
SE142C-384_FLAT_161

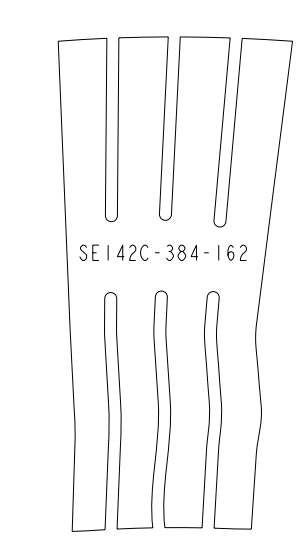

43

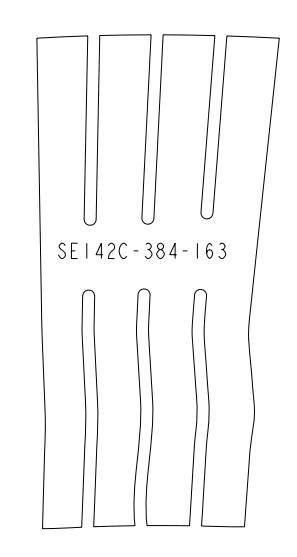

44

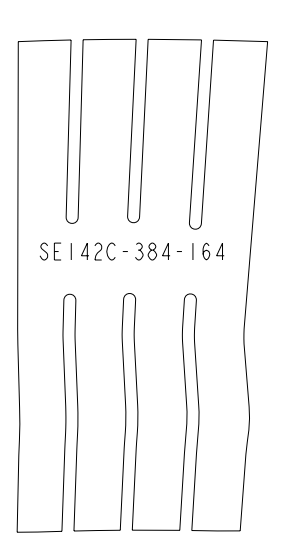

45

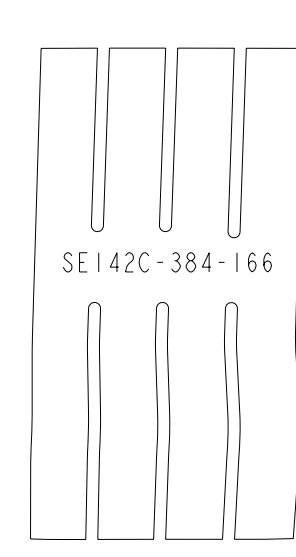

46

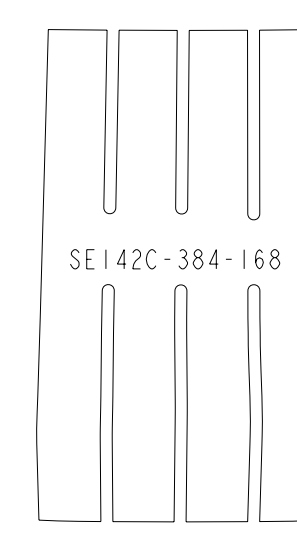

47

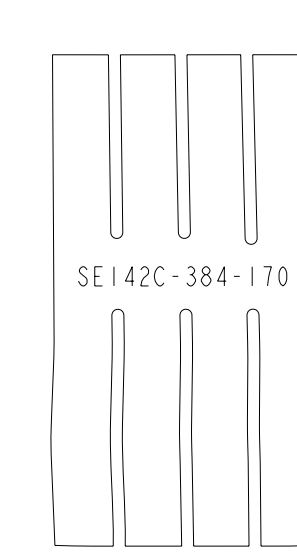

48

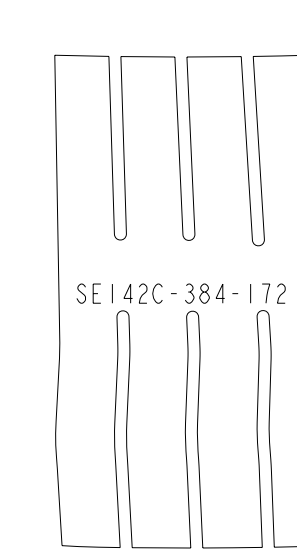

INSTANCE:
SE142C-384_FLAT_162

INSTANCE:
SE142C-384_FLAT_163

INSTANCE:
SE142C-384_FLAT_164

INSTANCE:
SE142C-384_FLAT_165

INSTANCE:
SE142C-384_FLAT_166

INSTANCE:
SE142C-384_FLAT_167

INSTANCE:
SE142C-384_FLAT_168

INSTANCE:
SE142C-384_FLAT_169

INSTANCE:
SE142C-384_FLAT_170

INSTANCE:
SE142C-384_FLAT_171

INSTANCE:
SE142C-384_FLAT_172

INSTANCE:
SE142C-384_FLAT_173

SCALE ALL VIEWS: 1.00

RELEASED FOR FABRICATION/INSTALLATION
PPPL Drafting

Oak Ridge National Laboratory managed for the DEPARTMENT OF ENERGY under U.S. GOVERNMENT CONTRACT DE-AC05-00OR22725 UT-BATTELLE, LLC, Oak Ridge, Tennessee PROJECT NAME:									
NATIONAL COMPACT STELLARATOR EXPERIMENT MODULAR COIL TYPE - C SIDE - A LOWER CLADDING FLAT PATTERN LAYOUT									
VERSION NO.	PLANT	BLDG	FL	SHT	OF	TYPE	CLASS		
4	X-10	5700	3	3	5	S	U		
RELEASE LEVEL		SE142C-384							
Fabrication									

8

7

6

5

4

3

2

1

SE142C-384

A

8

7

6

5

4

3

2

1

NEXT ASS'Y: FINAL ASS'Y:

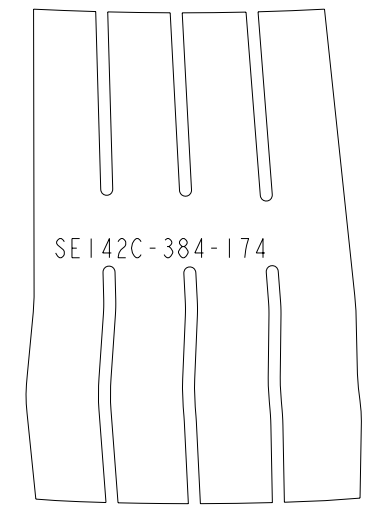

49

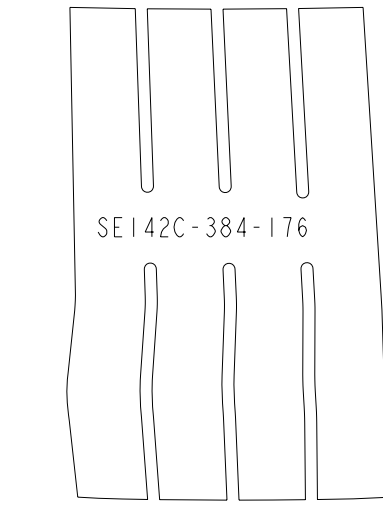
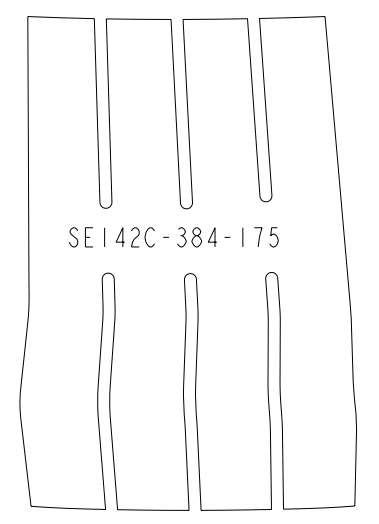

50

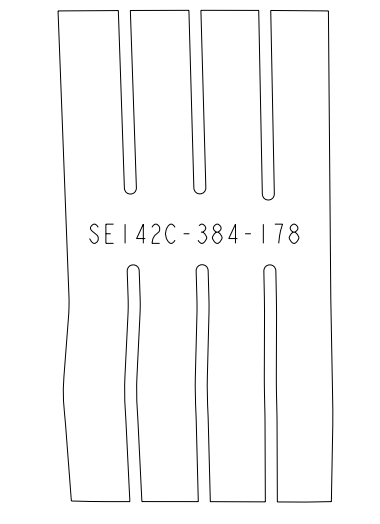
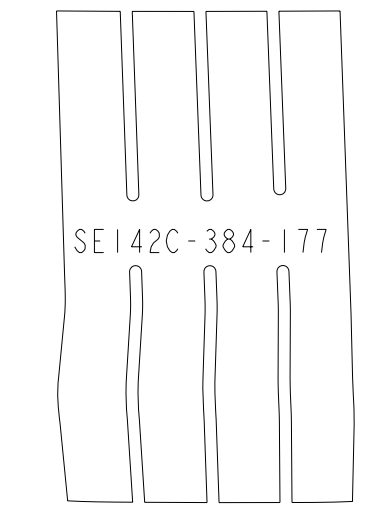

51

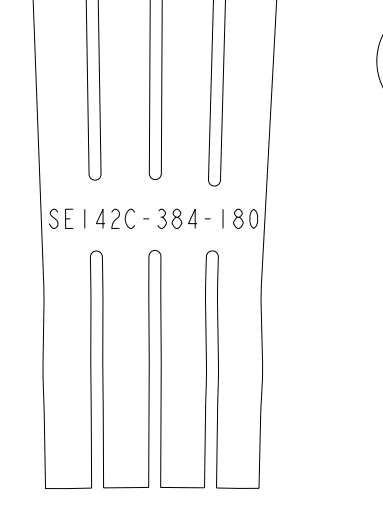
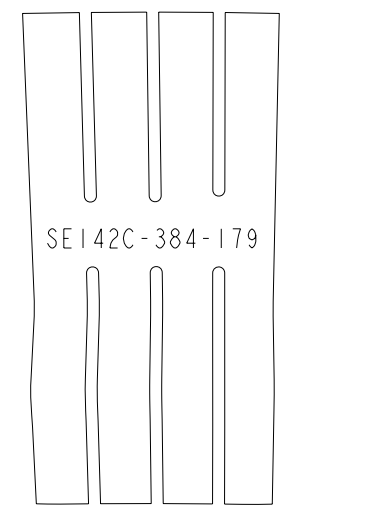

52

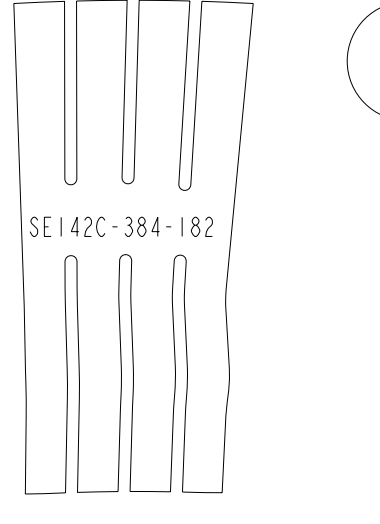
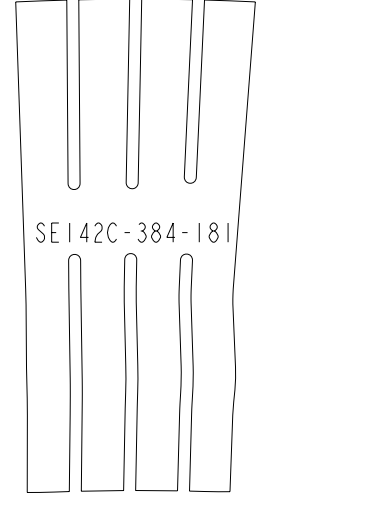

53

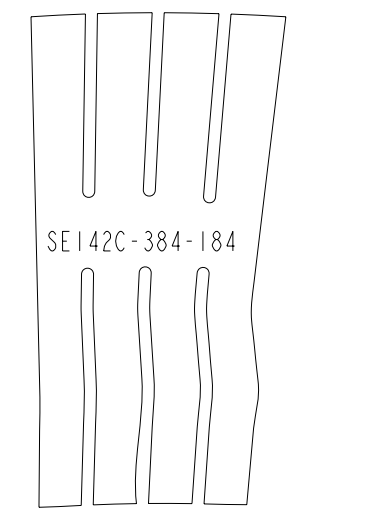
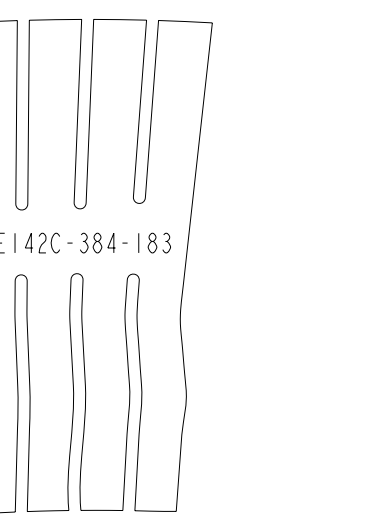

54

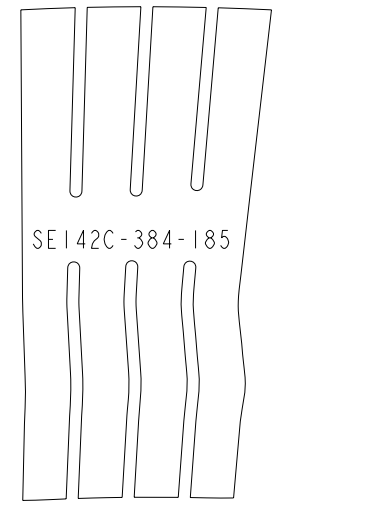

INSTANCE:
SE142C-384_FLAT_174

INSTANCE:
SE142C-384_FLAT_175

INSTANCE:
SE142C-384_FLAT_176

INSTANCE:
SE142C-384_FLAT_177

INSTANCE:
SE142C-384_FLAT_178

INSTANCE:
SE142C-384_FLAT_179

INSTANCE:
SE142C-384_FLAT_180

INSTANCE:
SE142C-384_FLAT_181

INSTANCE:
SE142C-384_FLAT_182

INSTANCE:
SE142C-384_FLAT_183

INSTANCE:
SE142C-384_FLAT_184

INSTANCE:
SE142C-384_FLAT_185

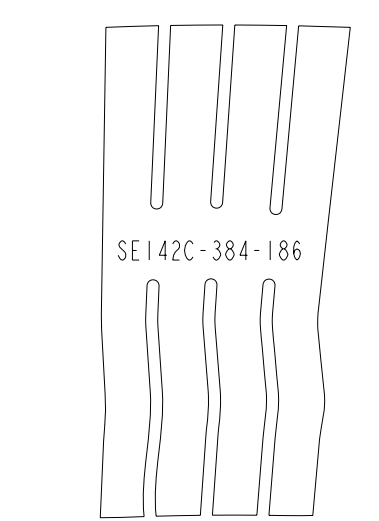

55

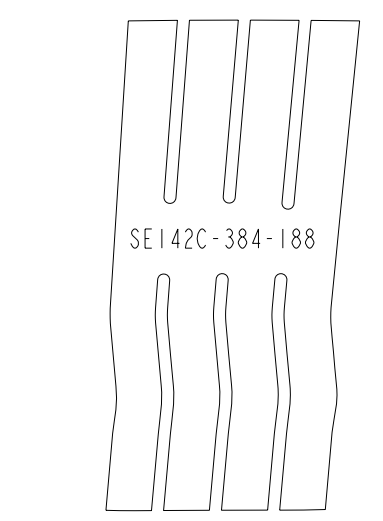
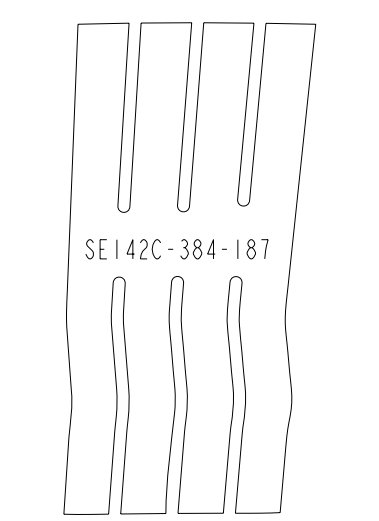

56

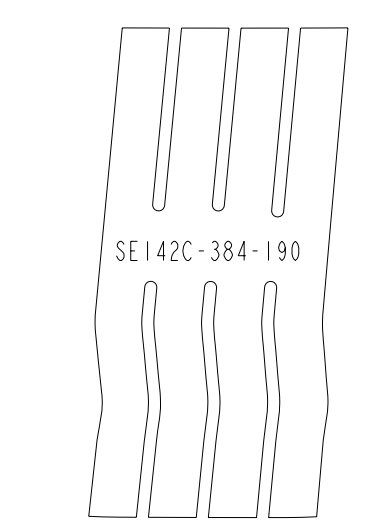
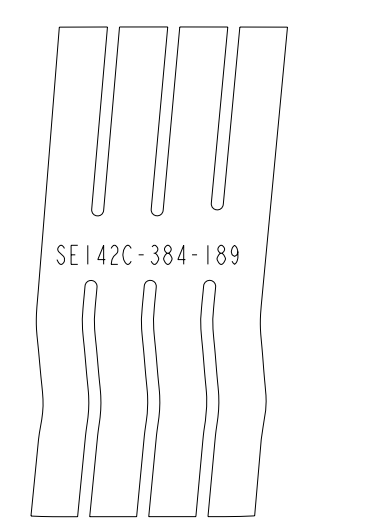

57

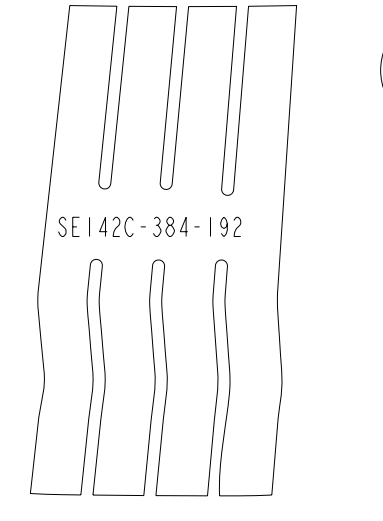
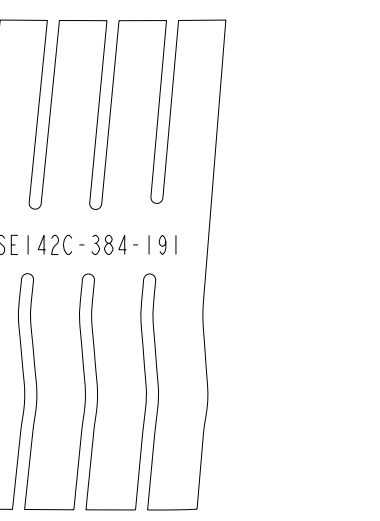

58

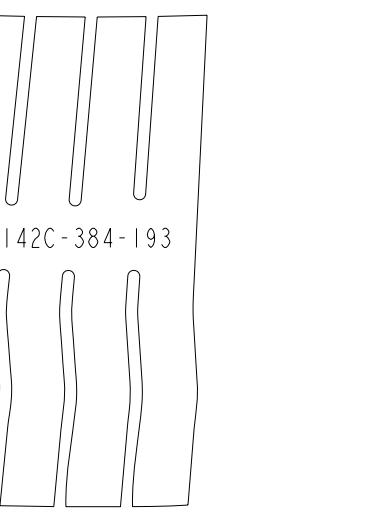

59

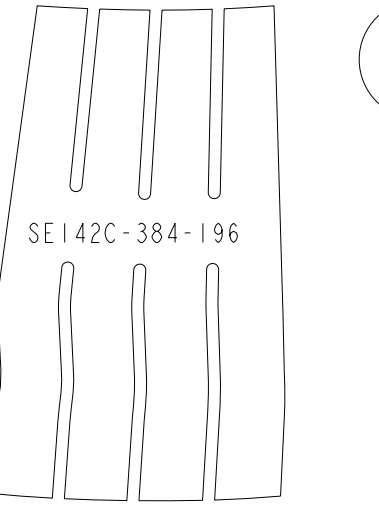
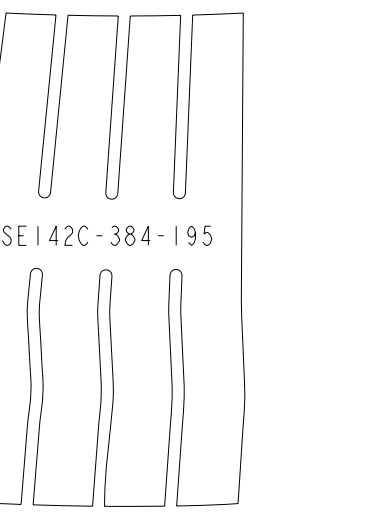

60

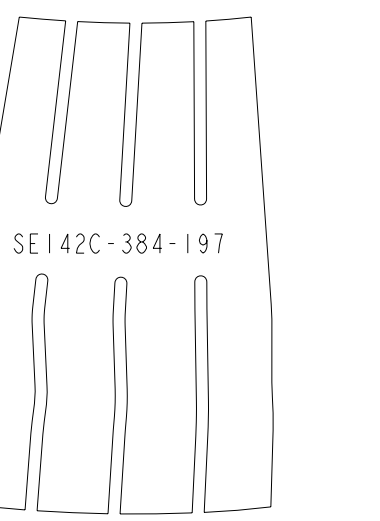

INSTANCE:
SE142C-384_FLAT_186

INSTANCE:
SE142C-384_FLAT_187

INSTANCE:
SE142C-384_FLAT_188

INSTANCE:
SE142C-384_FLAT_189

INSTANCE:
SE142C-384_FLAT_190

INSTANCE:
SE142C-384_FLAT_191

INSTANCE:
SE142C-384_FLAT_192

INSTANCE:
SE142C-384_FLAT_193

INSTANCE:
SE142C-384_FLAT_194

INSTANCE:
SE142C-384_FLAT_195_NEW

INSTANCE:
SE142C-384_FLAT_196

INSTANCE:
SE142C-384_FLAT_197

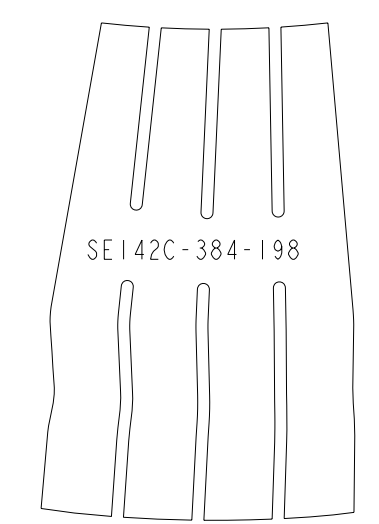

61

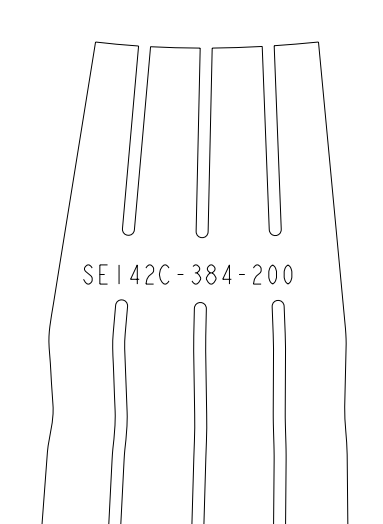
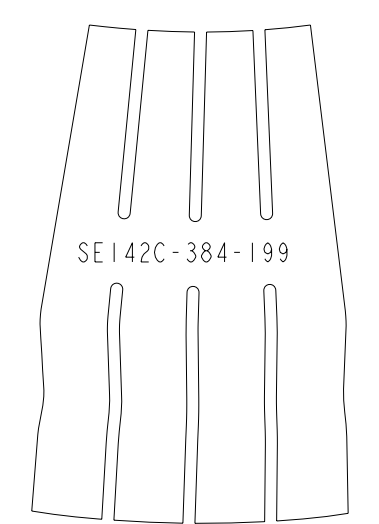

62

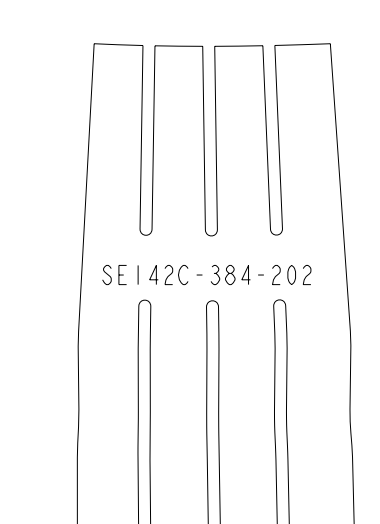
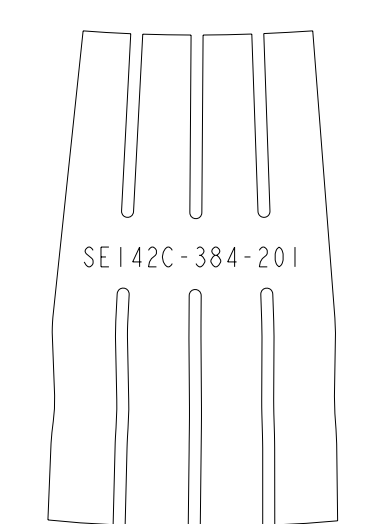

63

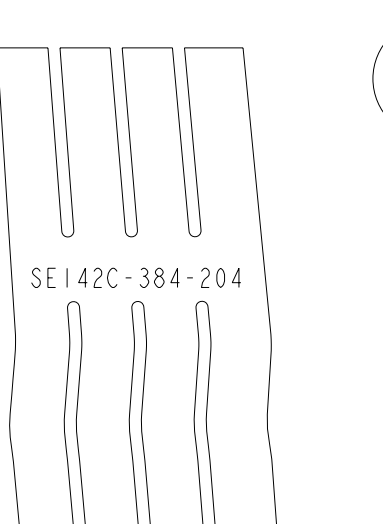
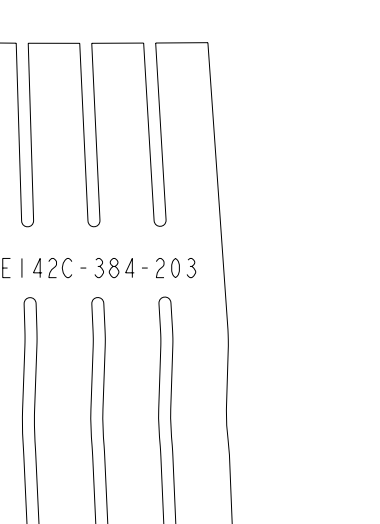

64

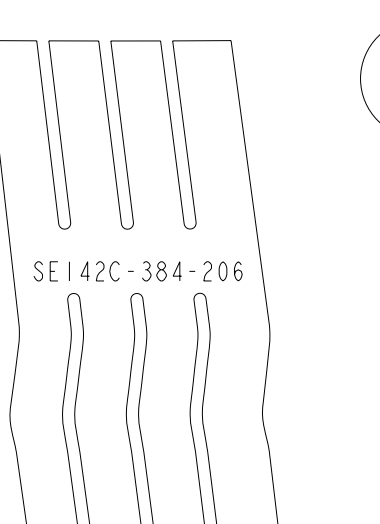
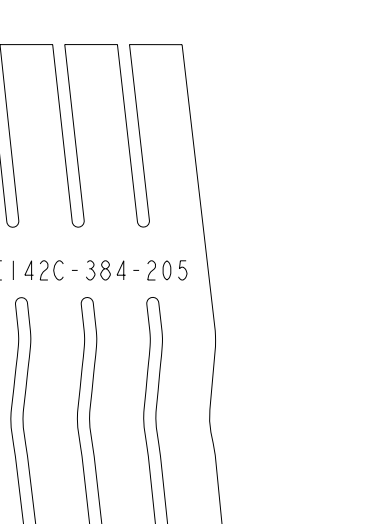

65

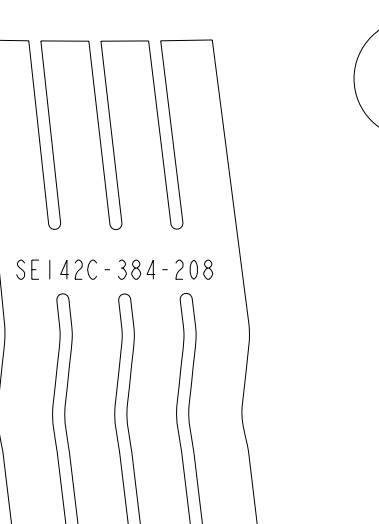
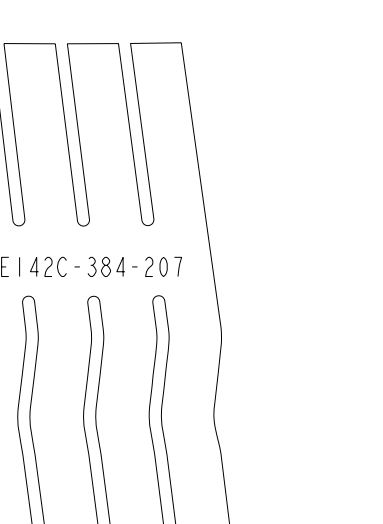

66

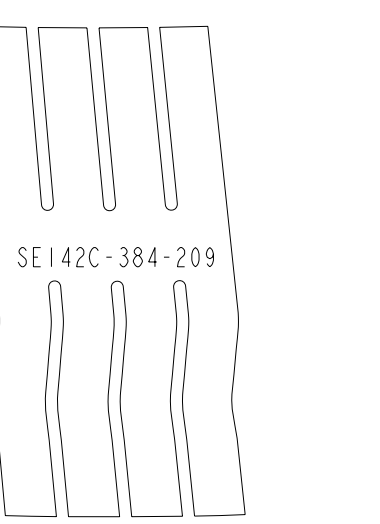

INSTANCE:
SE142C-384_FLAT_198

INSTANCE:
SE142C-384_FLAT_199

INSTANCE:
SE142C-384_FLAT_200

INSTANCE:
SE142C-384_FLAT_201

INSTANCE:
SE142C-384_FLAT_202

INSTANCE:
SE142C-384_FLAT_203

INSTANCE:
SE142C-384_FLAT_204

INSTANCE:
SE142C-384_FLAT_205

INSTANCE:
SE142C-384_FLAT_206

INSTANCE:
SE142C-384_FLAT_207

INSTANCE:
SE142C-384_FLAT_208

INSTANCE:
SE142C-384_FLAT_209

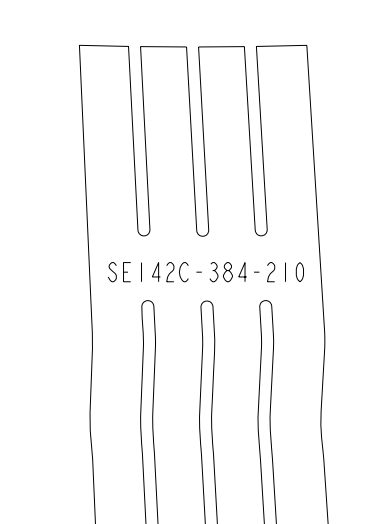

67

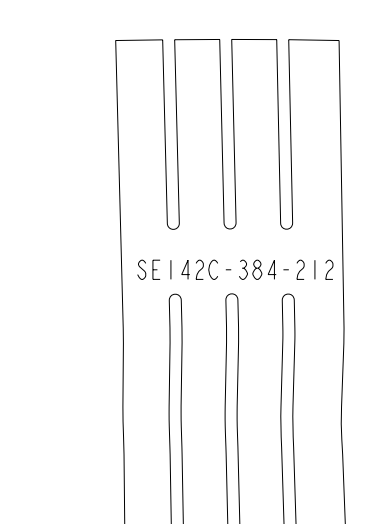
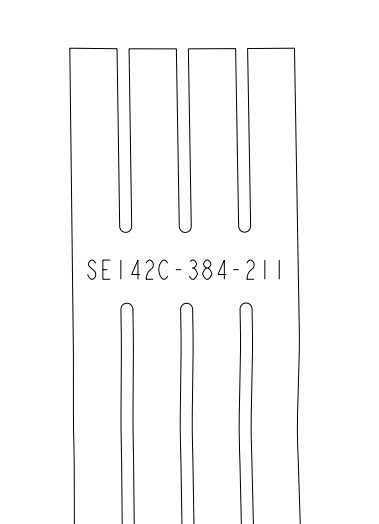

68

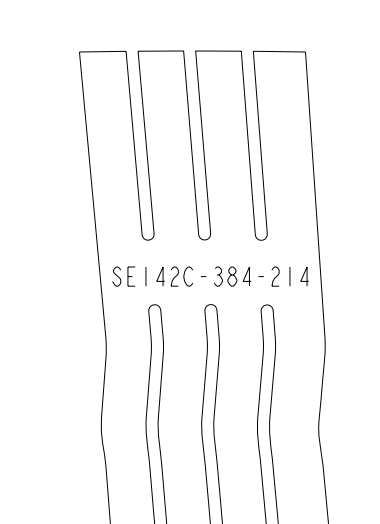
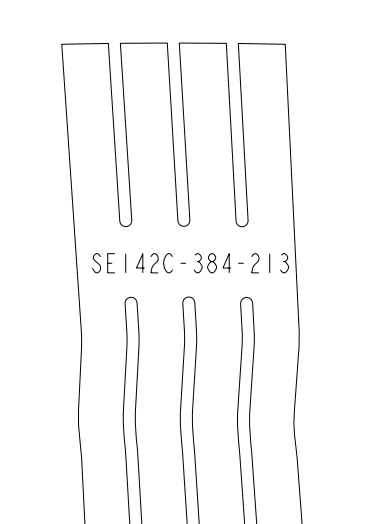

69

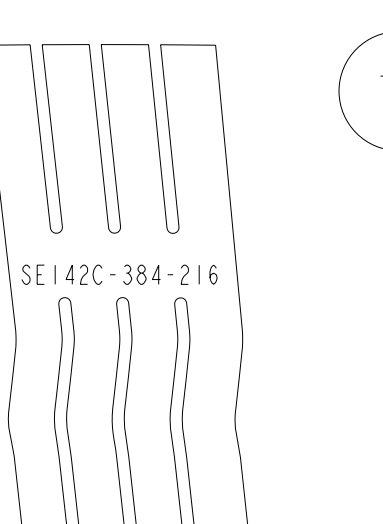
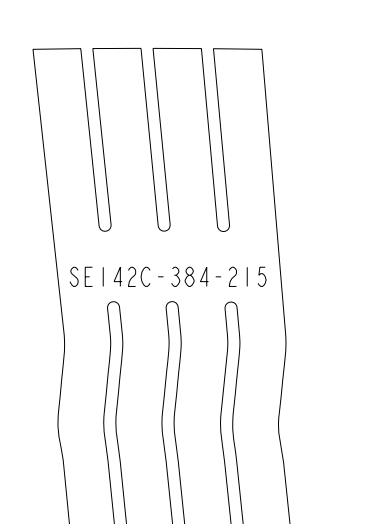

70

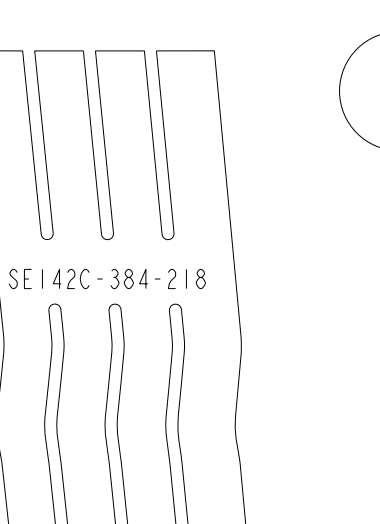
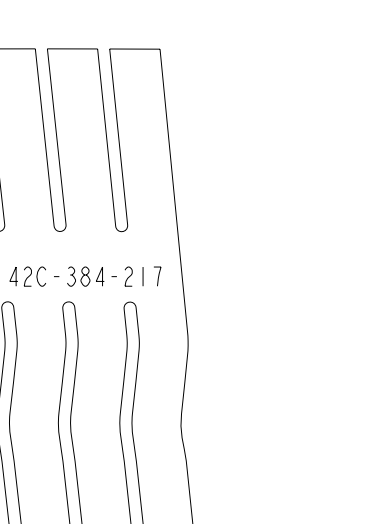

71

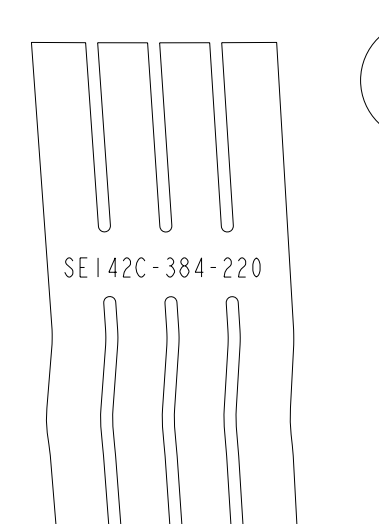
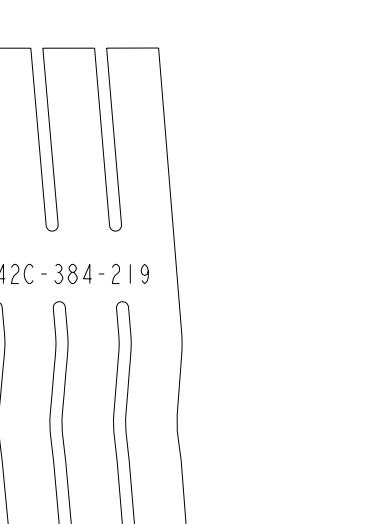

72

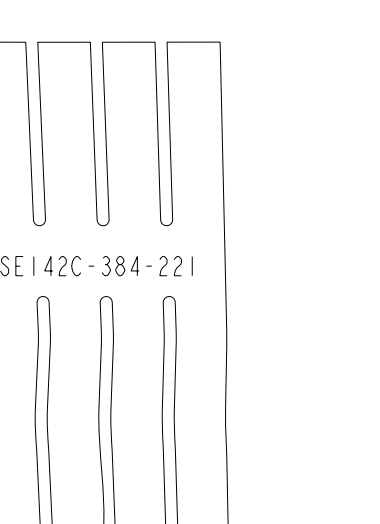

INSTANCE:
SE142C-384_FLAT_210

INSTANCE:
SE142C-384_FLAT_211

INSTANCE:
SE142C-384_FLAT_212

INSTANCE:
SE142C-384_FLAT_213

INSTANCE:
SE142C-384_FLAT_214

INSTANCE:
SE142C-384_FLAT_215

INSTANCE:
SE142C-384_FLAT_216

INSTANCE:
SE142C-384_FLAT_217

INSTANCE:
SE142C-384_FLAT_218

INSTANCE:
SE142C-384_FLAT_219

INSTANCE:
SE142C-384_FLAT_220

INSTANCE:
SE142C-384_FLAT_221

SCALE ALL VIEWS: 1.00

RELEASED FOR FABRICATION / INSTALLATION
PPPL Drafting

UT-BATTELLE										Oak Ridge National Laboratory managed for the DEPARTMENT OF ENERGY under U.S. GOVERNMENT contract DE-AC05-00OR22725 UT-BATTELLE, LLC, Oak Ridge, Tennessee									
PROJECT NAME										NATIONAL COMPACT STELLARATOR EXPERIMENT									
MODULAR COIL TYPE - C										SIDE - A LOWER CLADDING									
FLAT PATTERN LAYOUT																			
VERSION NO.	PLANT	BLDG	FL	SHT	OF	TYPE	CLASS												
4	X-10	5700	3	4	5	S	U												
RELEASE LEVEL		SE142C-384								REV		I							
Fabrication																			

8

7

6

5

4

3

2

1

SE142C-384

A

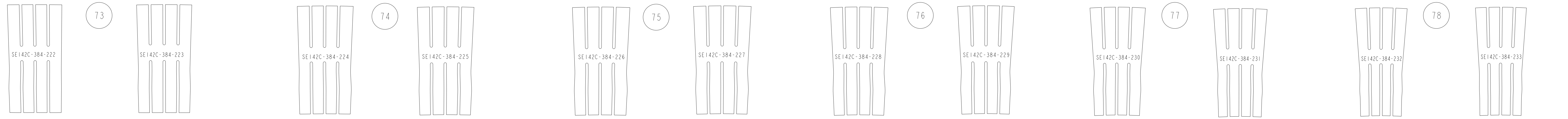

INSTANCE: SEI42C-384_FLAT_222 INSTANCE: SEI42C-384_FLAT_223 INSTANCE: SEI42C-384_FLAT_224 INSTANCE: SEI42C-384_FLAT_225 INSTANCE: SEI42C-384_FLAT_226 INSTANCE: SEI42C-384_FLAT_227 INSTANCE: SEI42C-384_FLAT_228 INSTANCE: SEI42C-384_FLAT_229 INSTANCE: SEI42C-384_FLAT_230 INSTANCE: SEI42C-384_FLAT_231 INSTANCE: SEI42C-384_FLAT_232 INSTANCE: SEI42C-384_FLAT_233

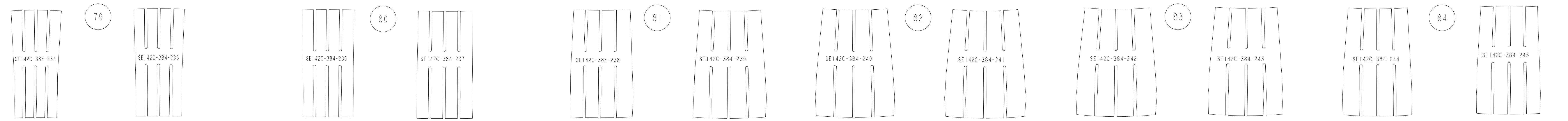

INSTANCE: SEI42C-384_FLAT_234 INSTANCE: SEI42C-384_FLAT_235 INSTANCE: SEI42C-384_FLAT_236 INSTANCE: SEI42C-384_FLAT_237 INSTANCE: SEI42C-384_FLAT_238 INSTANCE: SEI42C-384_FLAT_239 INSTANCE: SEI42C-384_FLAT_240 INSTANCE: SEI42C-384_FLAT_241 INSTANCE: SEI42C-384_FLAT_242 INSTANCE: SEI42C-384_FLAT_243 INSTANCE: SEI42C-384_FLAT_244 INSTANCE: SEI42C-384_FLAT_245

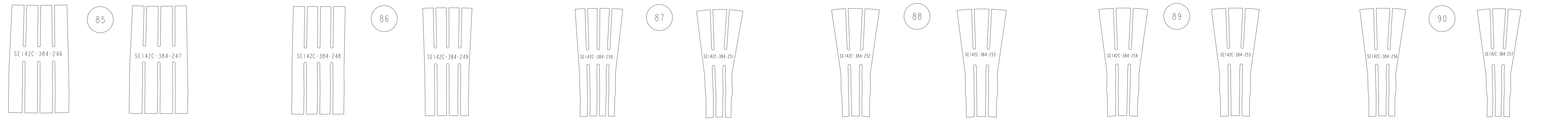

INSTANCE: SEI42C-384_FLAT_246 INSTANCE: SEI42C-384_FLAT_247 INSTANCE: SEI42C-384_FLAT_248 INSTANCE: SEI42C-384_FLAT_249 INSTANCE: SEI42C-384_FLAT_250 INSTANCE: SEI42C-384_FLAT_NEW-251 INSTANCE: SEI42C-384_FLAT_NEW-252 INSTANCE: SEI42C-384_FLAT_NEW-253 INSTANCE: SEI42C-384_FLAT_NEW-254 INSTANCE: SEI42C-384_FLAT_NEW-255 INSTANCE: SEI42C-384_FLAT_NEW-256 INSTANCE: SEI42C-384_FLAT_NEW-257

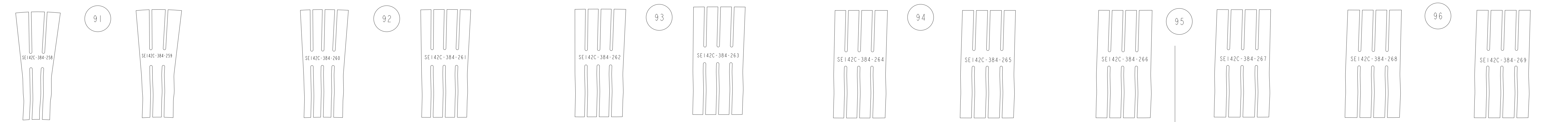

INSTANCE: SEI42C-384_FLAT_NEW-258 INSTANCE: SEI42C-384_FLAT_NEW-259 INSTANCE: SEI42C-384_FLAT_260 INSTANCE: SEI42C-384_FLAT_261 INSTANCE: SEI42C-384_FLAT_262 INSTANCE: SEI42C-384_FLAT_263 INSTANCE: SEI42C-384_FLAT_264 INSTANCE: SEI42C-384_FLAT_265 INSTANCE: SEI42C-384_FLAT_266 INSTANCE: SEI42C-384_FLAT_267 INSTANCE: SEI42C-384_FLAT_268 INSTANCE: SEI42C-384_FLAT_269

1 THESE PARTS TO BE NEMA GRADE GIICR MATERIAL

SCALE ALL VIEWS: 1.00

RELEASED FOR FABRICATION / INSTALLATION PPPI Drafting:

UT-BATTELLE		Oak Ridge National Laboratory managed for the DEPARTMENT OF ENERGY under U.S. GOVERNMENT contract DE-AC05-00OR22725 UT-BATTELLE, LLC. Oak Ridge, Tennessee	
PROJECT NAME			
NATIONAL COMPACT STELLARATOR EXPERIMENT			
MODULAR COIL TYPE - C			
SIDE - A LOWER CLADDING			
FLAT PATTERN LAYOUT			
VERSION NO.	PLANT	BLDG	FL SHT OF TYPE CLASS
4	X-10	5700	3 5 5 S U
RELEASE LEVEL		SEI42C-384	
Fabrication		REV I	