

INSTANCE: SEI42C-482_FLAT_125
INSTANCE: SEI42C-482_FLAT_124

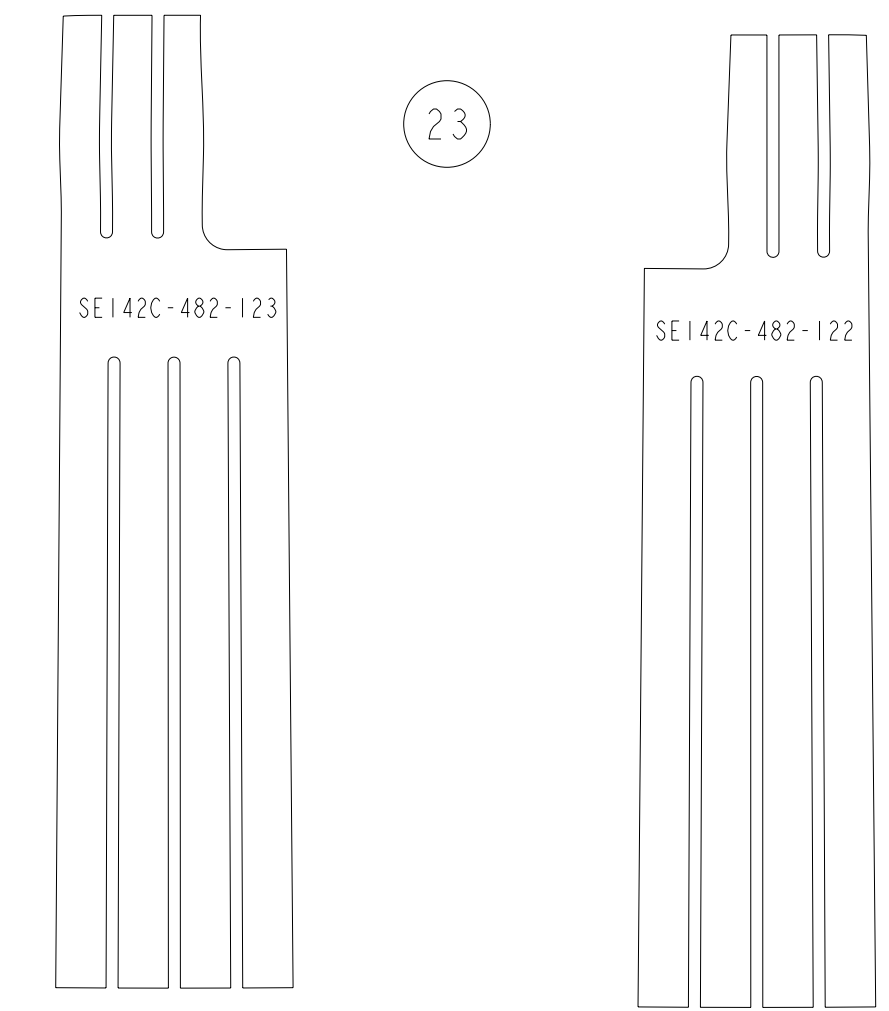

INSTANCE: SEI42C-482_FLAT_123
INSTANCE: SEI42C-482_FLAT_122

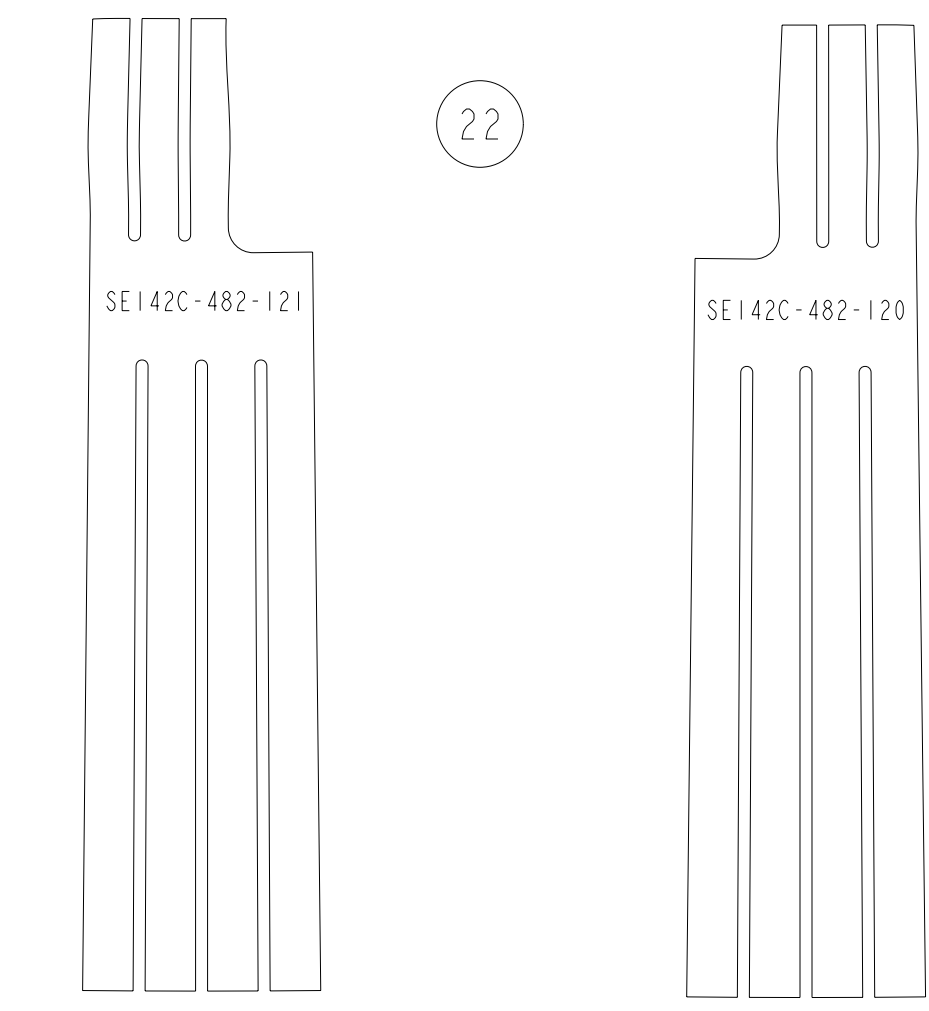

INSTANCE: SEI42C-482_FLAT_121
INSTANCE: SEI42C-482_FLAT_120

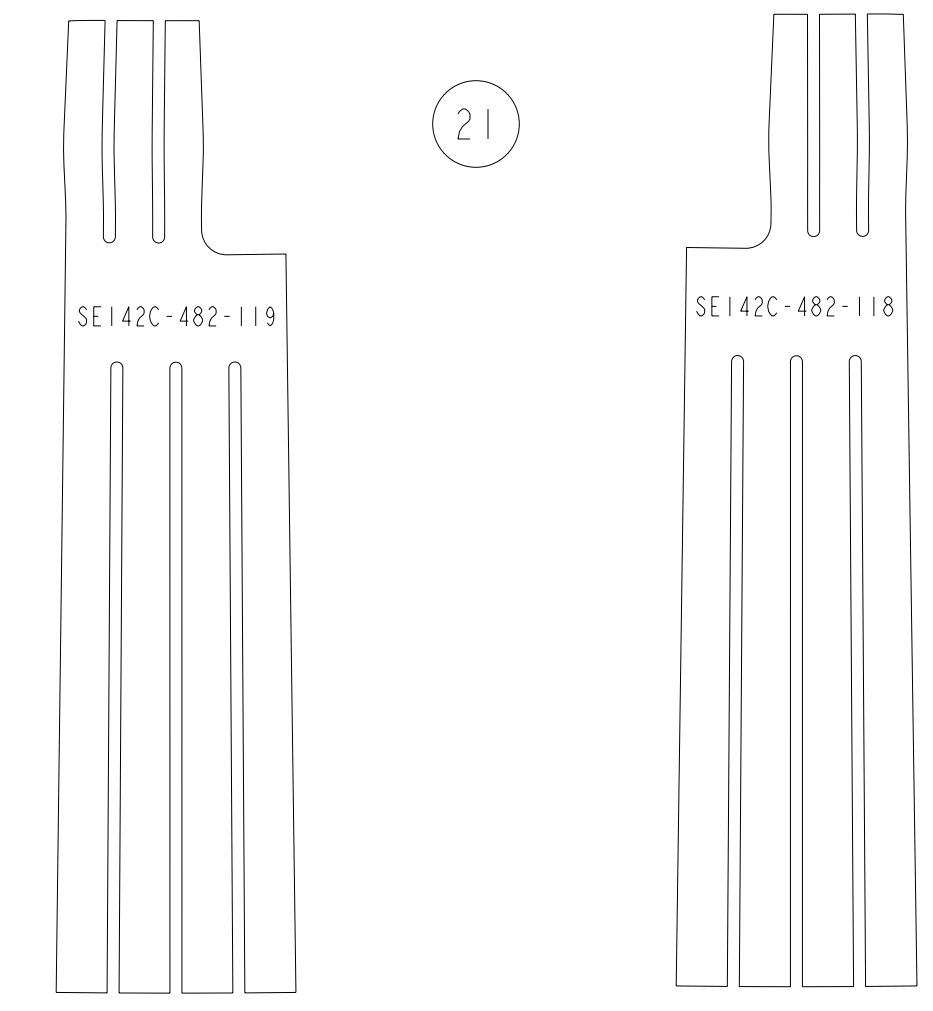

INSTANCE: SEI42C-482_FLAT_119
INSTANCE: SEI42C-482_FLAT_118

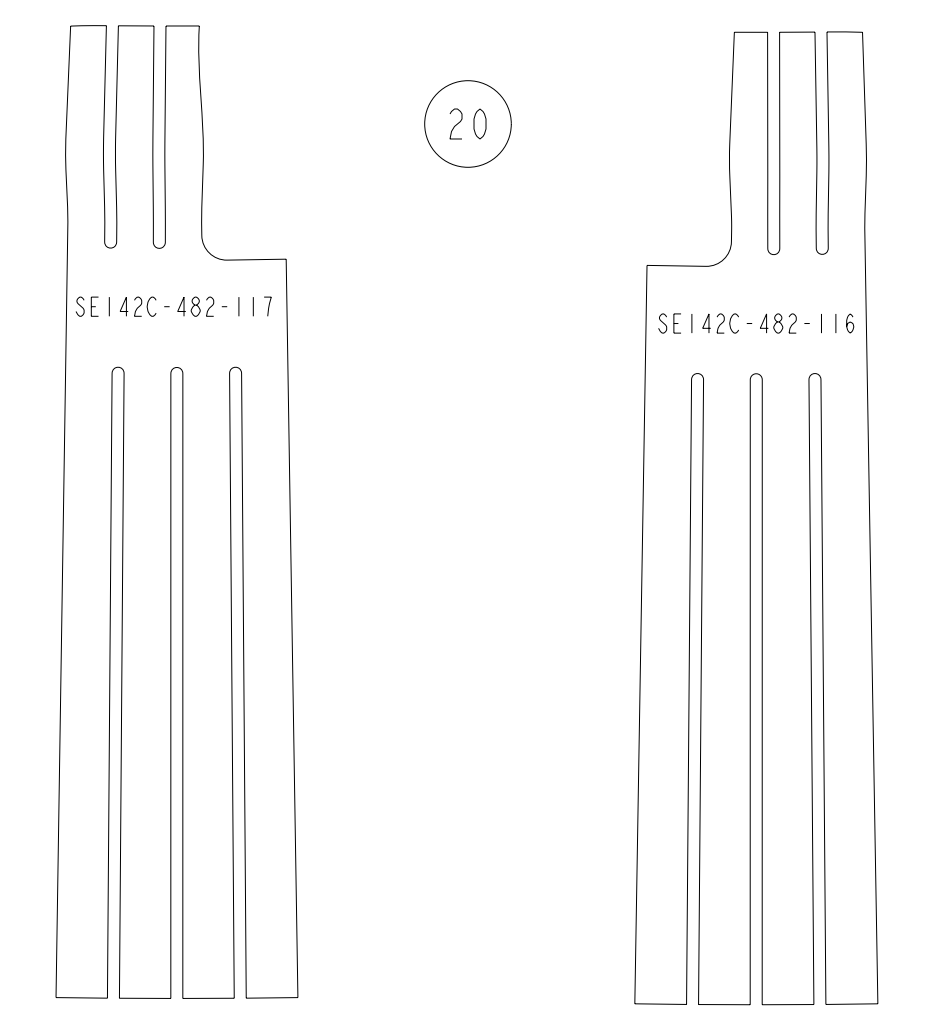

INSTANCE: SEI42C-482_FLAT_117
INSTANCE: SEI42C-482_FLAT_116

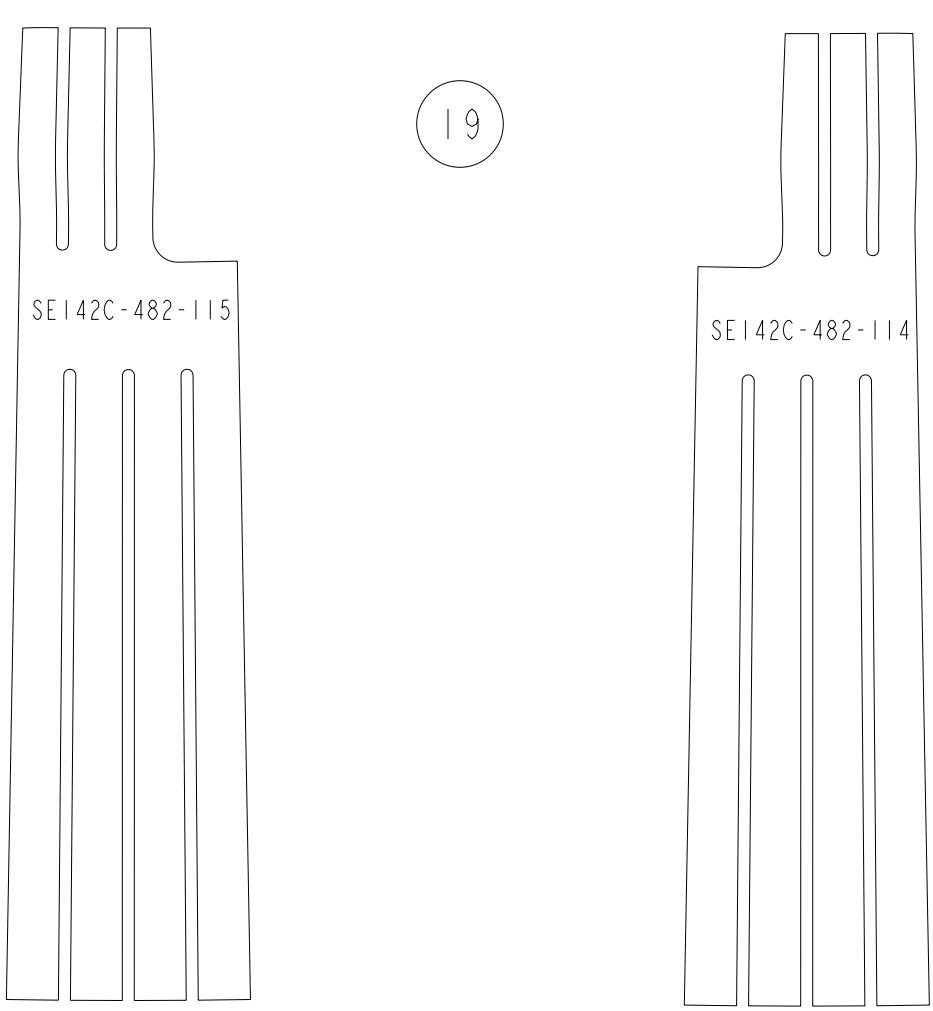

INSTANCE: SEI42C-482_FLAT_115
INSTANCE: SEI42C-482_FLAT_114

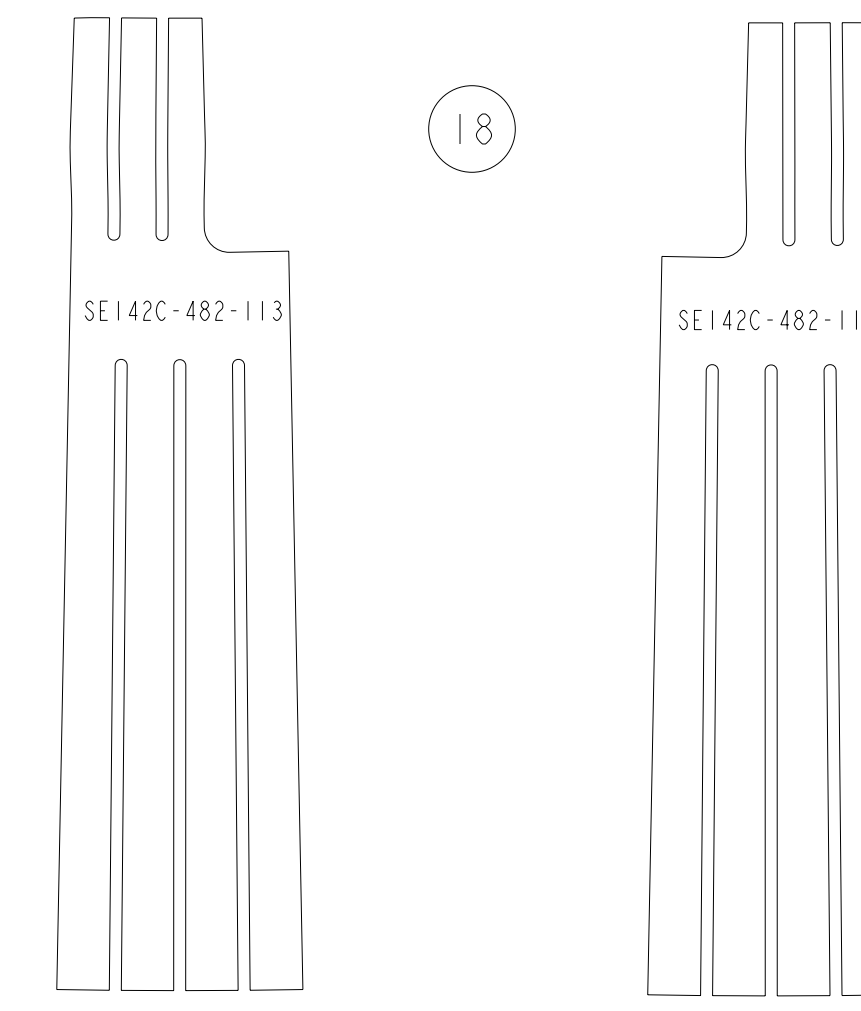

INSTANCE: SEI42C-482_FLAT_113
INSTANCE: SEI42C-482_FLAT_112

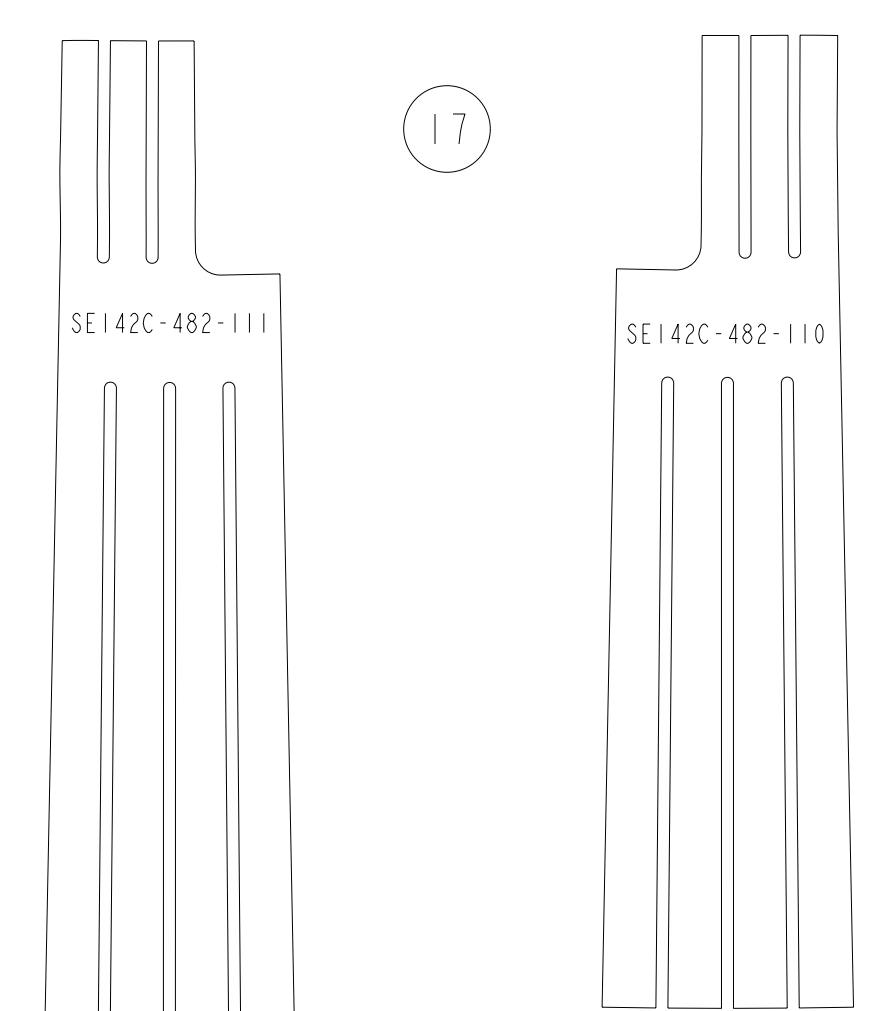

INSTANCE: SEI42C-482_FLAT_111
INSTANCE: SEI42C-482_FLAT_110

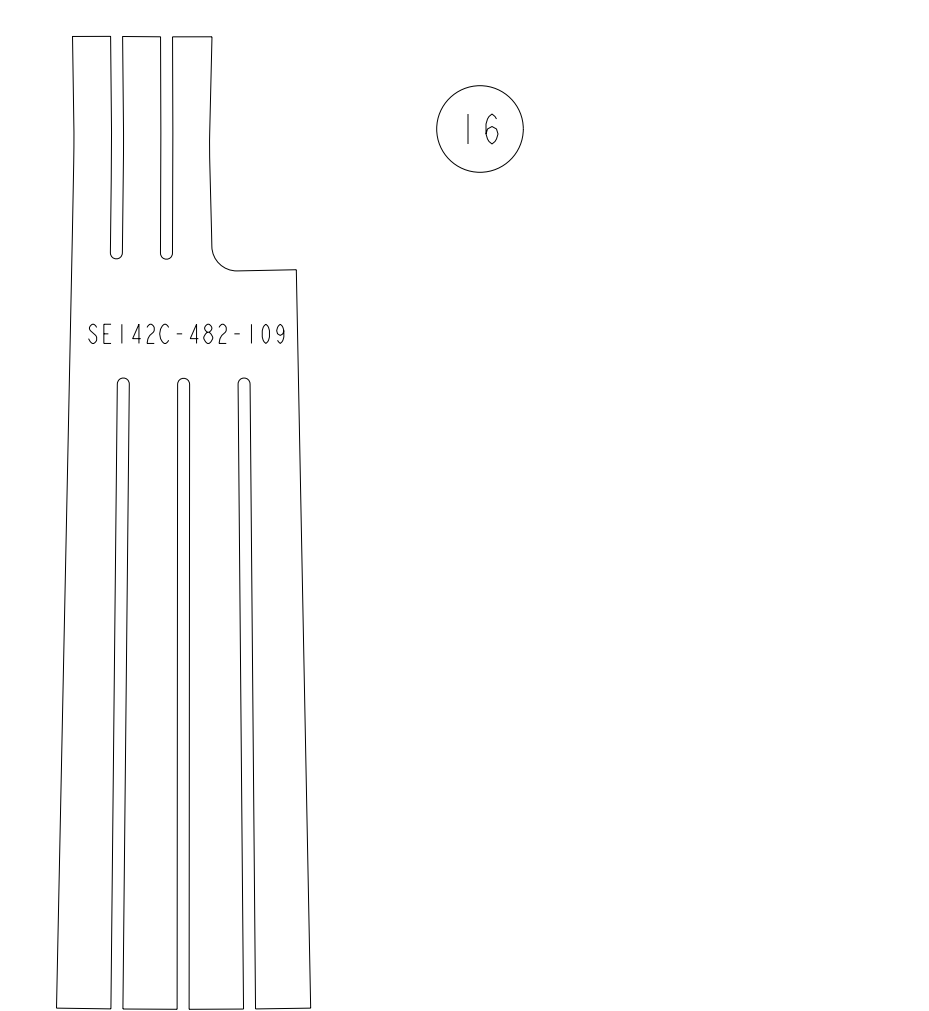

INSTANCE: SEI42C-482_FLAT_109

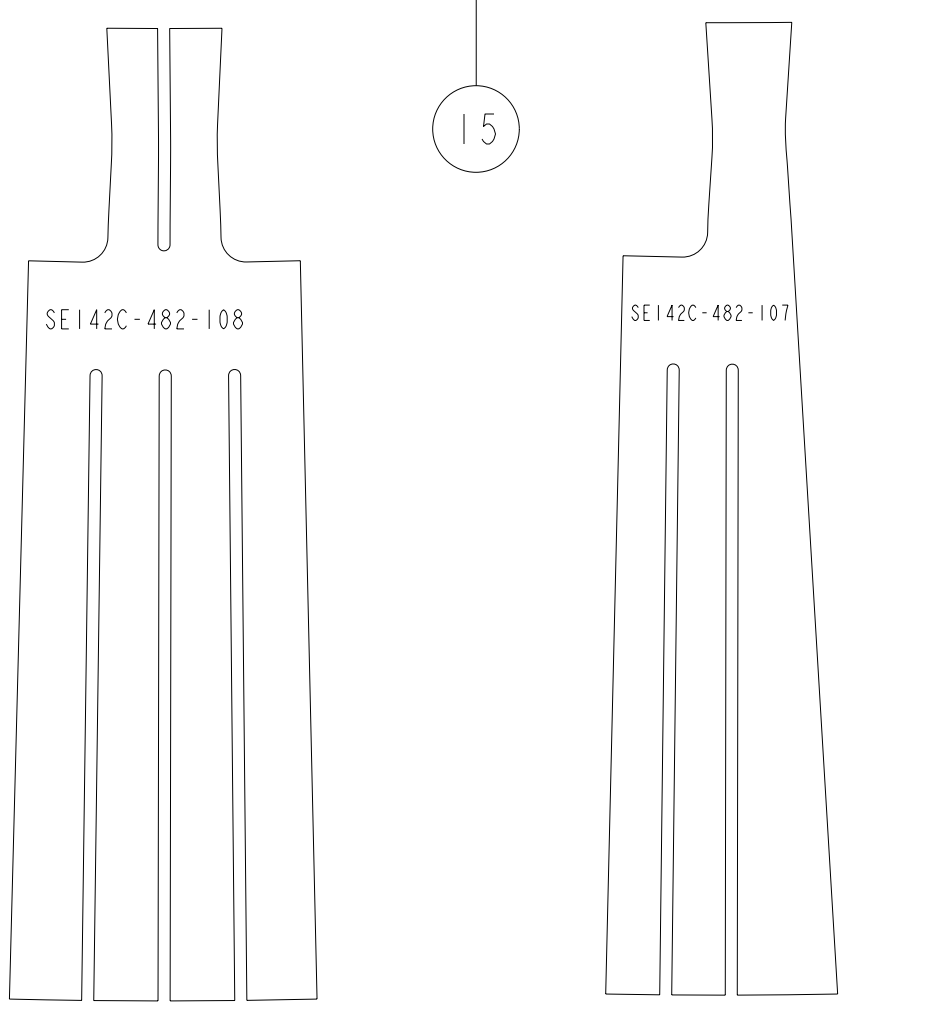

INSTANCE: SEI42C-482_FLAT_108-NEW
INSTANCE: SEI42C-482_FLAT_107-NEW

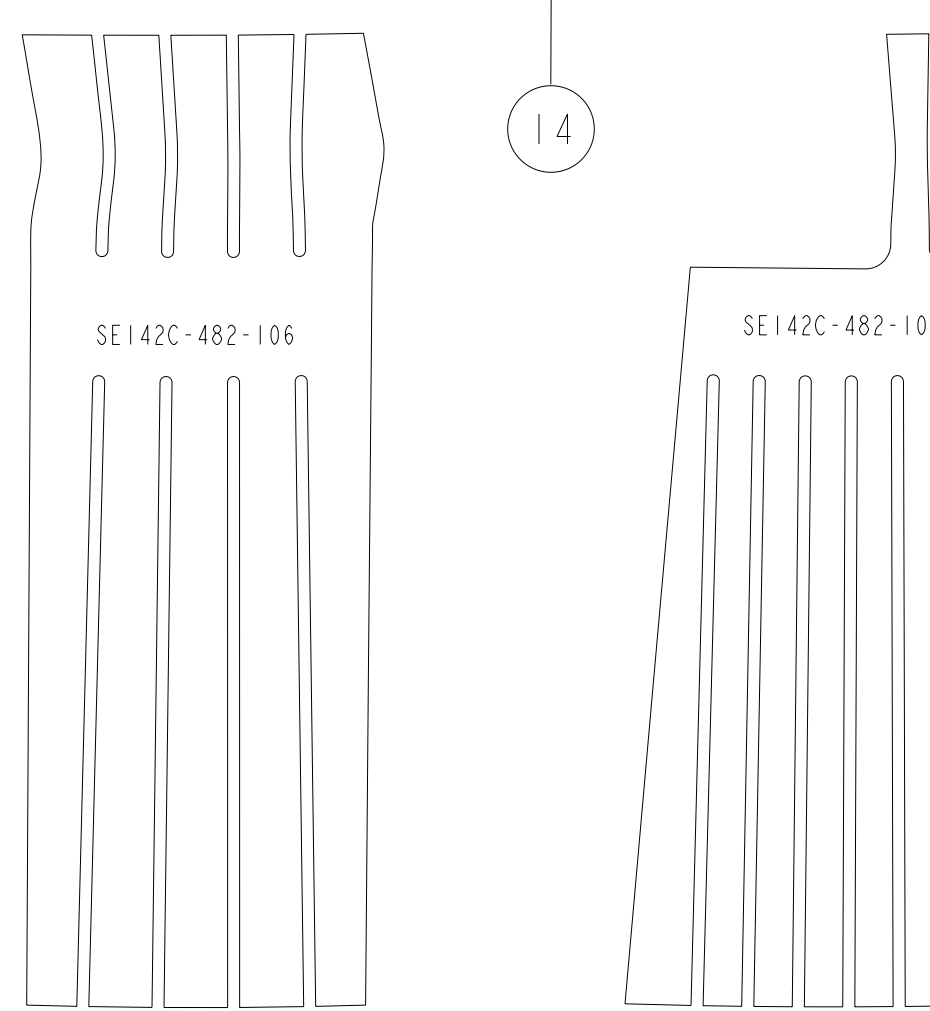

INSTANCE: SEI42C-482_FLAT_106-NEW
INSTANCE: SEI42C-482_FLAT_104-NEW

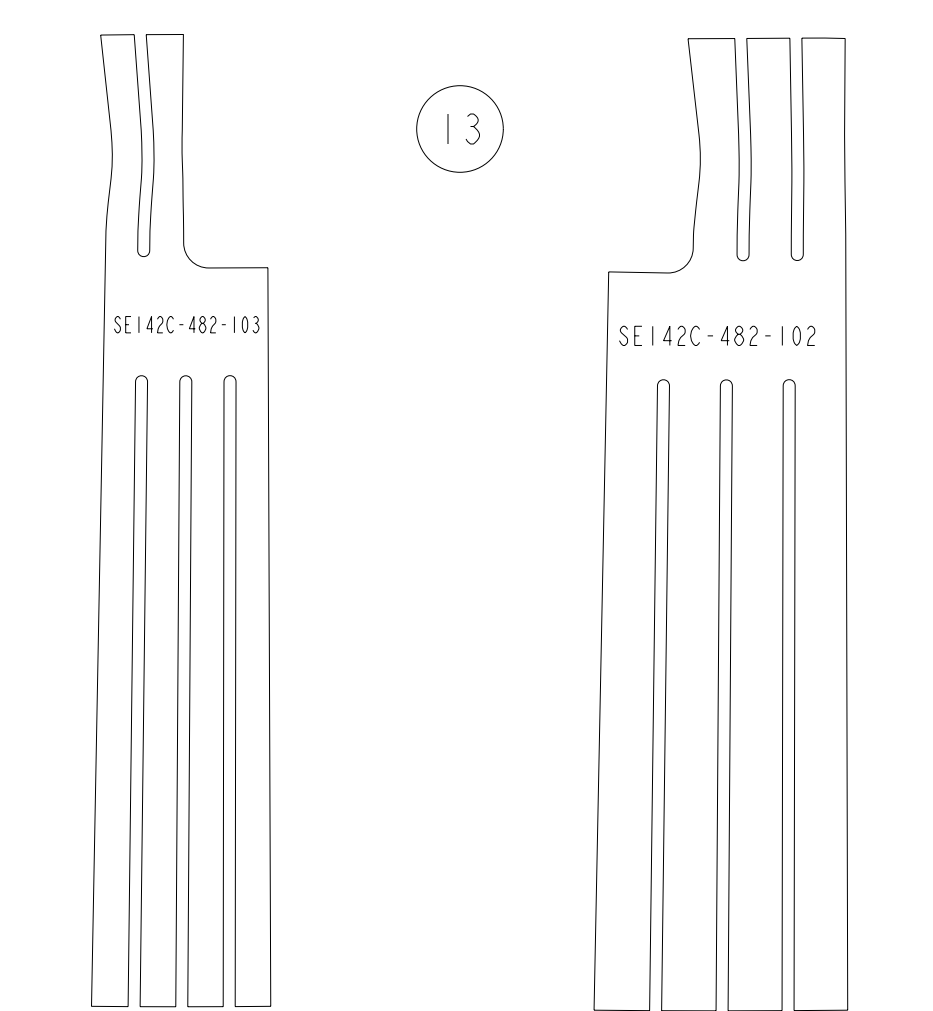

INSTANCE: SEI42C-482_FLAT_103-NEW
INSTANCE: SEI42C-482_FLAT_102-NEW

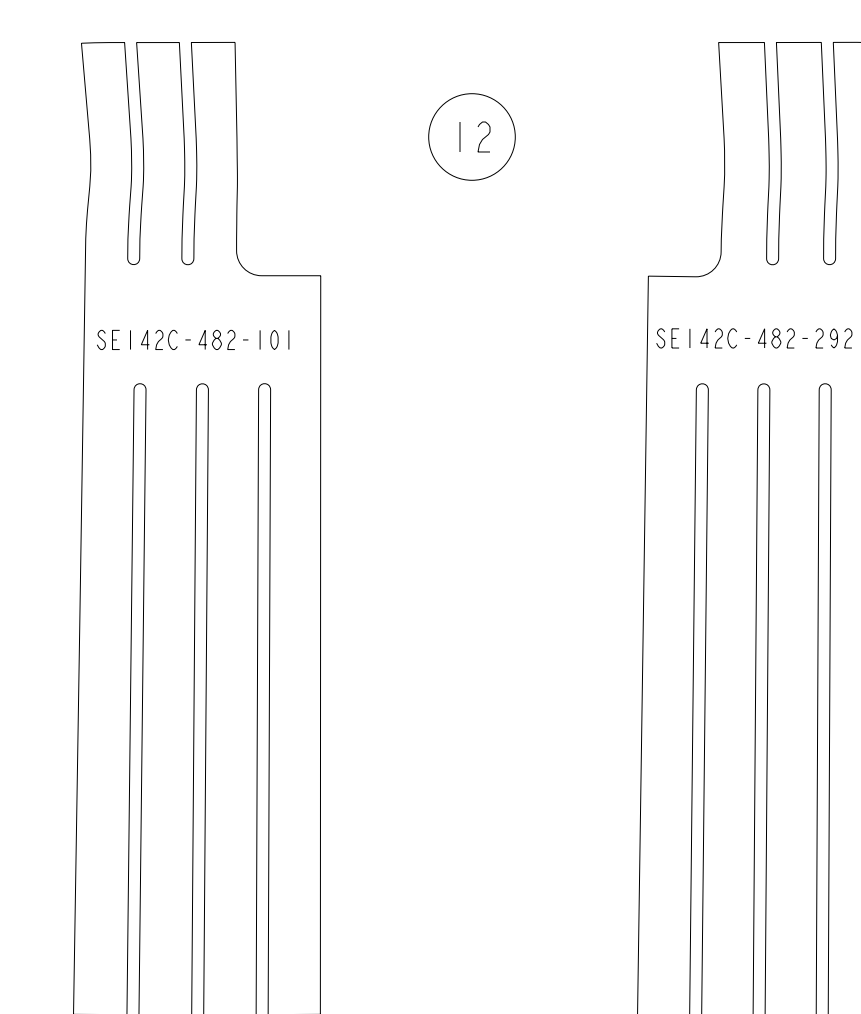

INSTANCE: SEI42C-482_FLAT_101
INSTANCE: SEI42C-482_FLAT_292-NEW

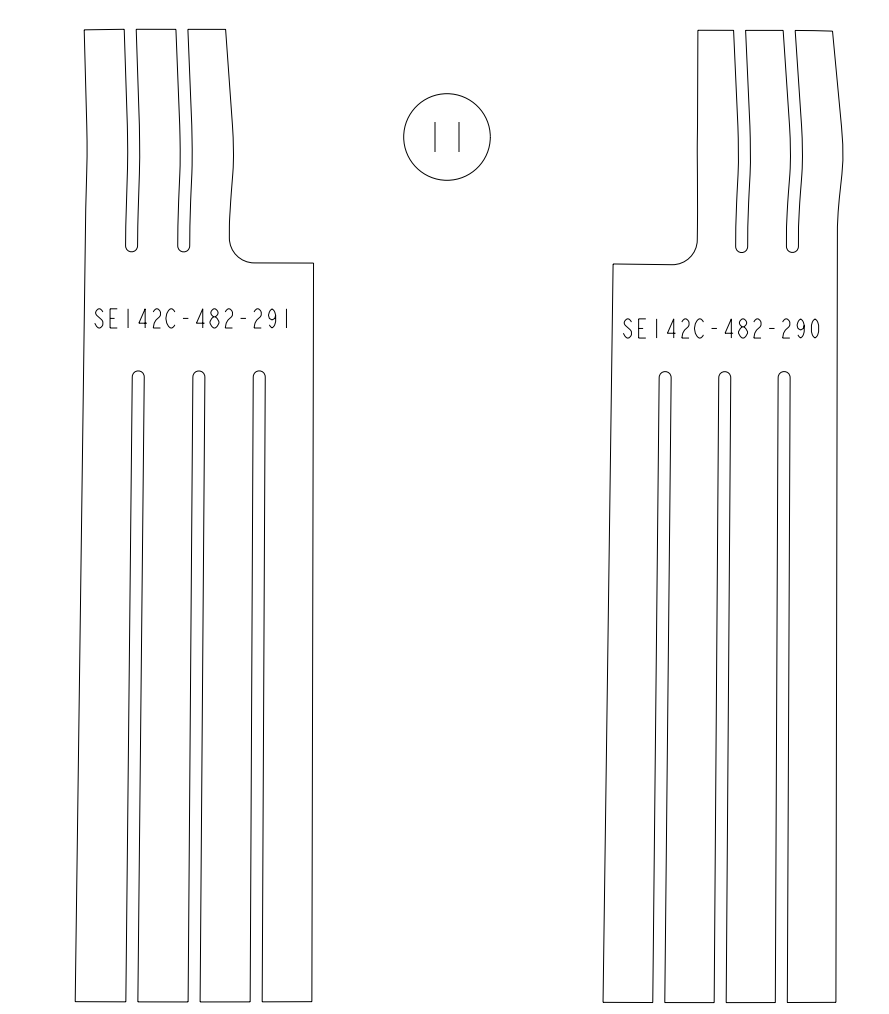

INSTANCE: SEI42C-482_FLAT_291
INSTANCE: SEI42C-482_FLAT_290

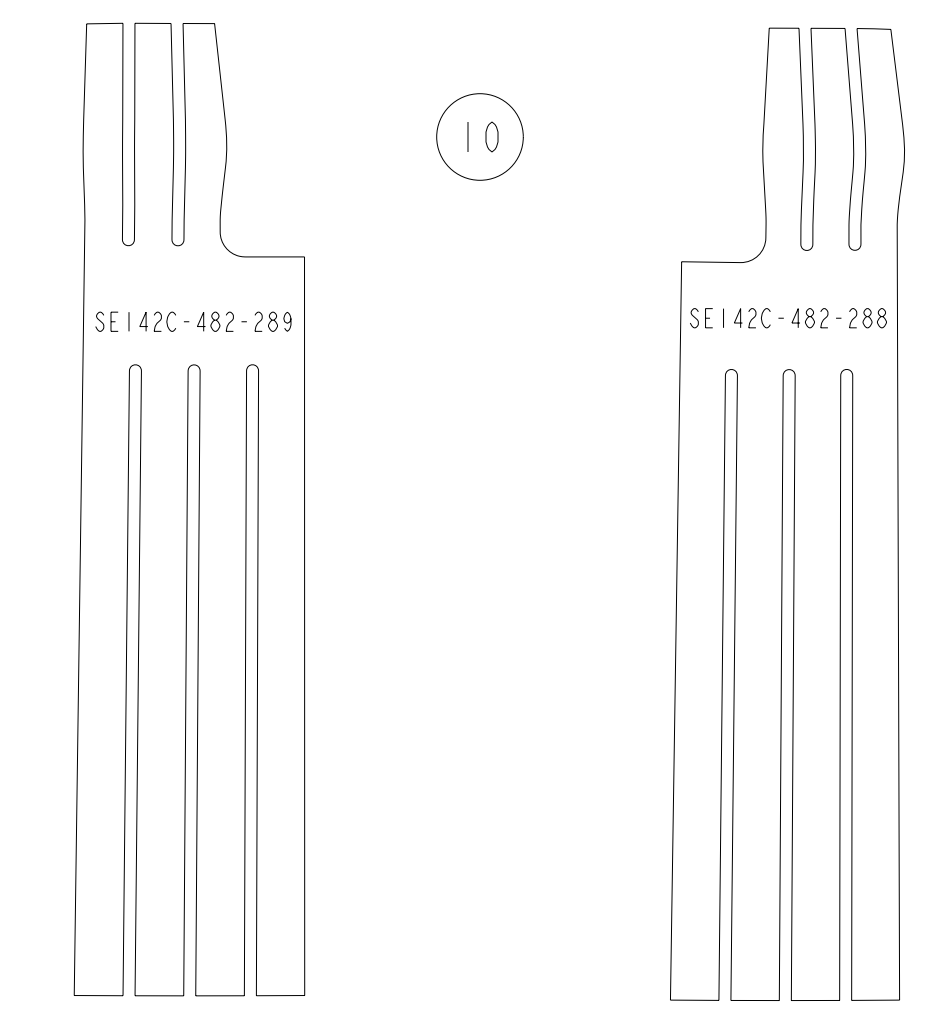

INSTANCE: SEI42C-482_FLAT_289
INSTANCE: SEI42C-482_FLAT_288

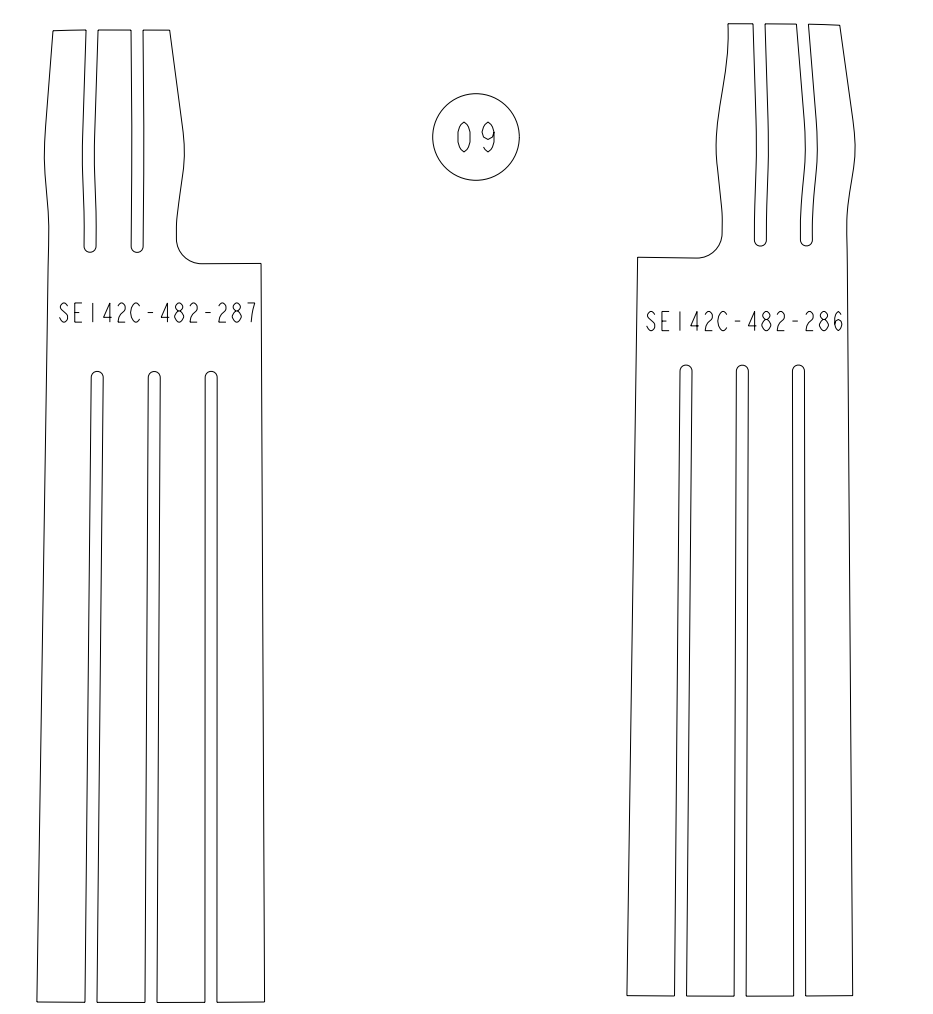

INSTANCE: SEI42C-482_FLAT_287
INSTANCE: SEI42C-482_FLAT_286

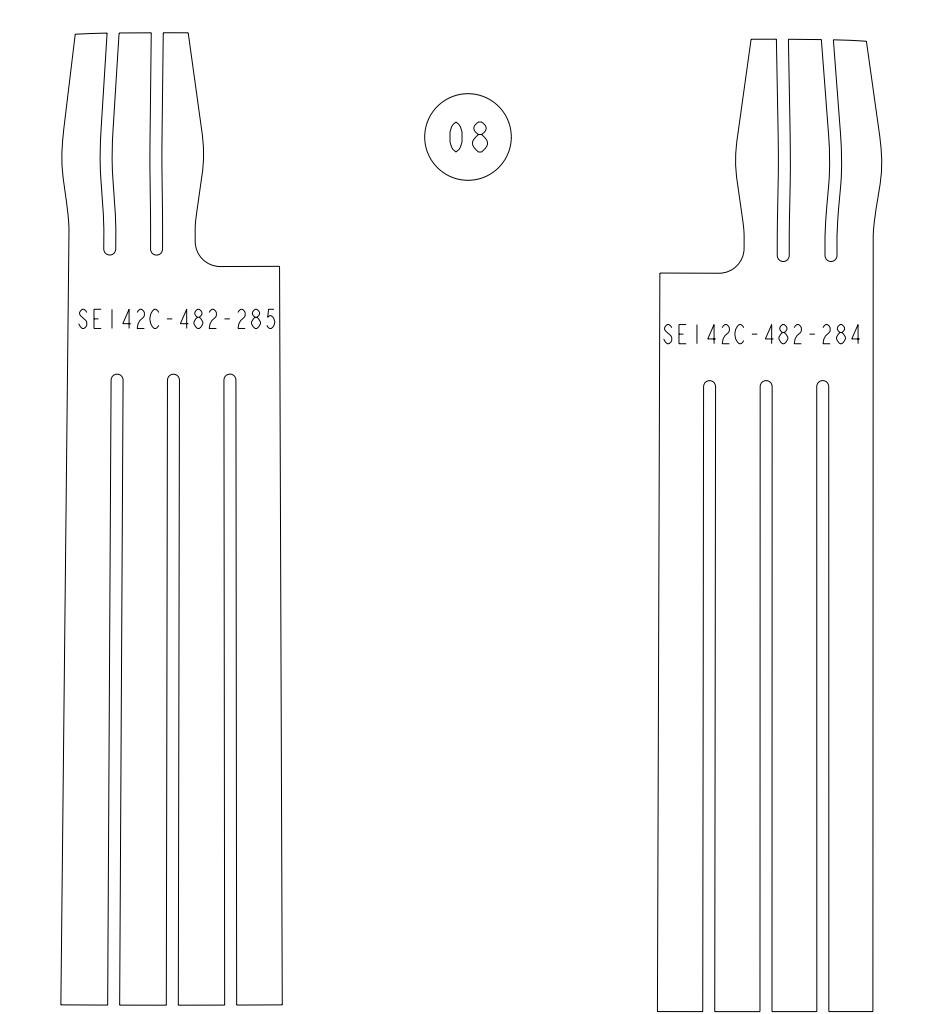

INSTANCE: SEI42C-482_FLAT_285
INSTANCE: SEI42C-482_FLAT_284

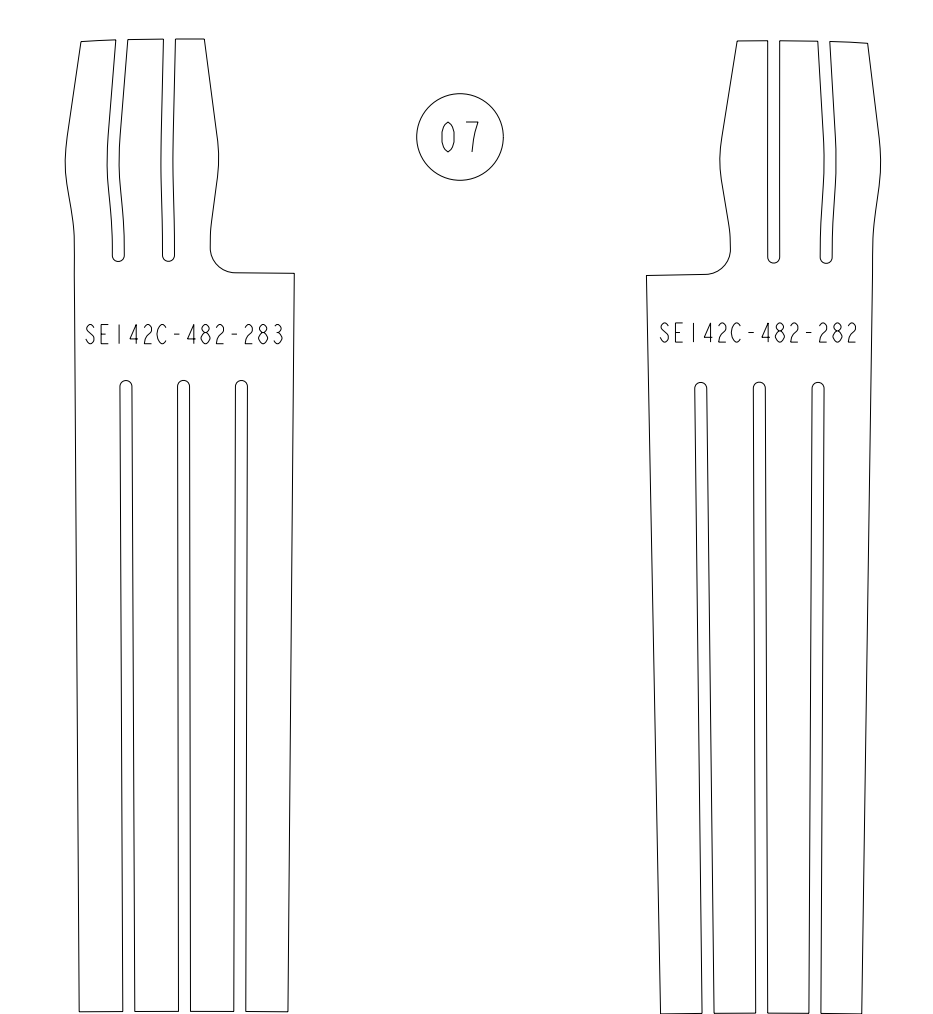

INSTANCE: SEI42C-482_FLAT_283
INSTANCE: SEI42C-482_FLAT_282

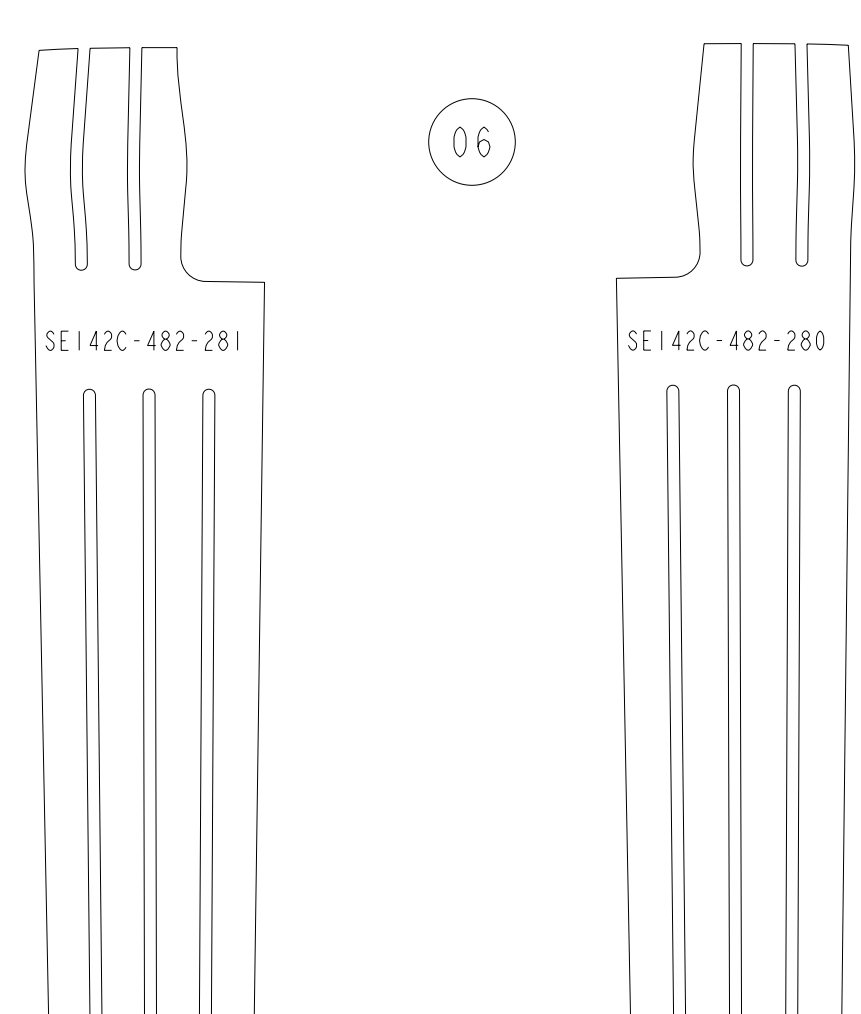

INSTANCE: SEI42C-482_FLAT_281
INSTANCE: SEI42C-482_FLAT_280

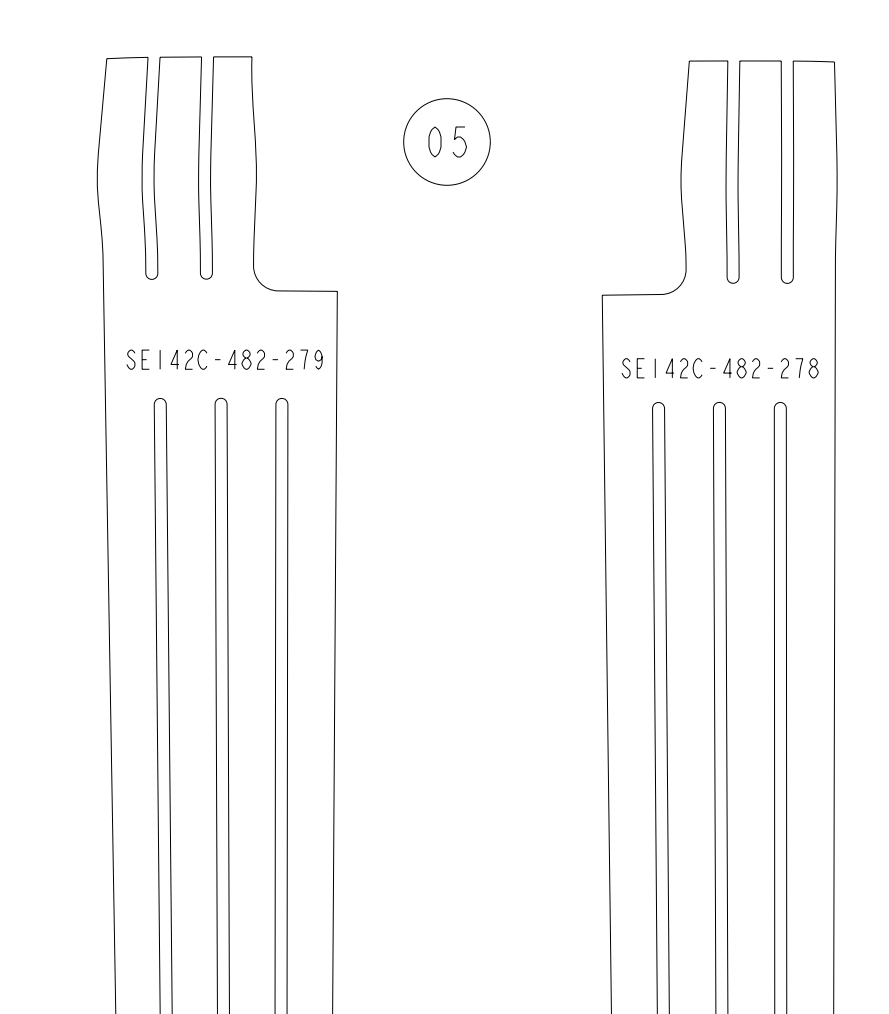

INSTANCE: SEI42C-482_FLAT_279
INSTANCE: SEI42C-482_FLAT_278

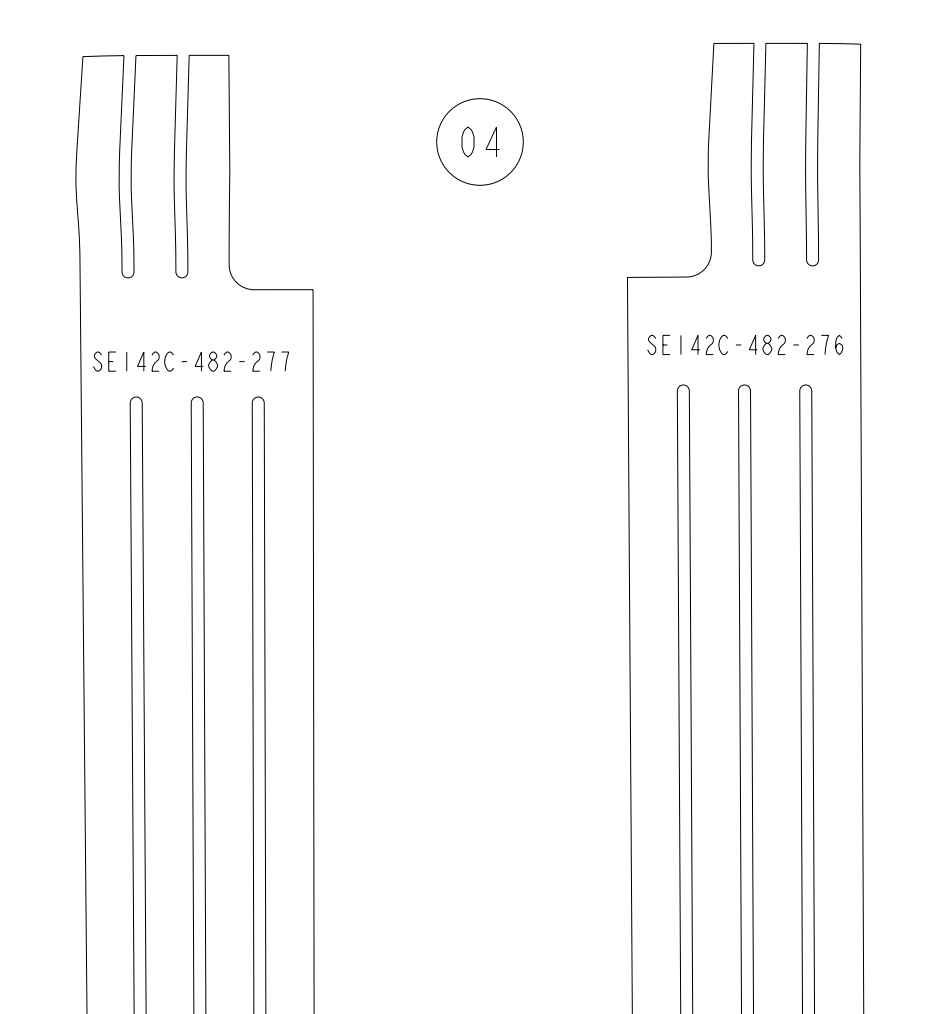

INSTANCE: SEI42C-482_FLAT_277
INSTANCE: SEI42C-482_FLAT_276

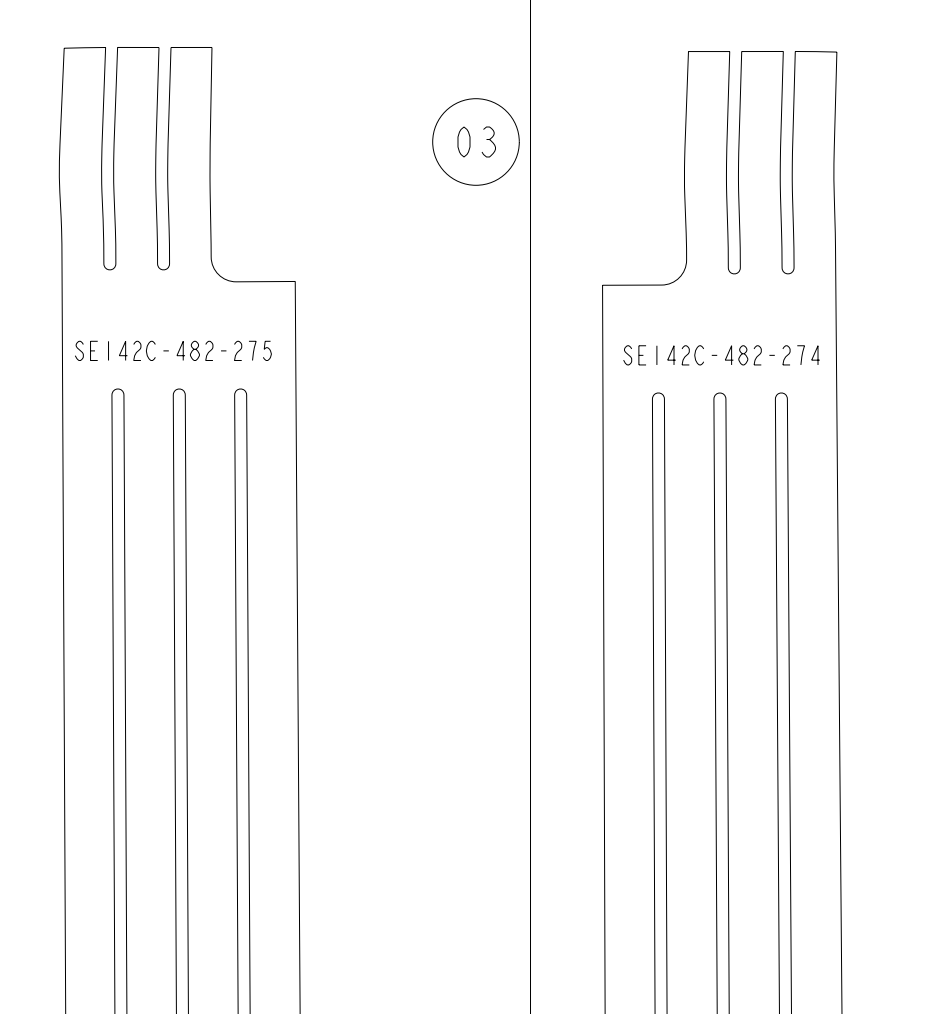

INSTANCE: SEI42C-482_FLAT_275
INSTANCE: SEI42C-482_FLAT_274

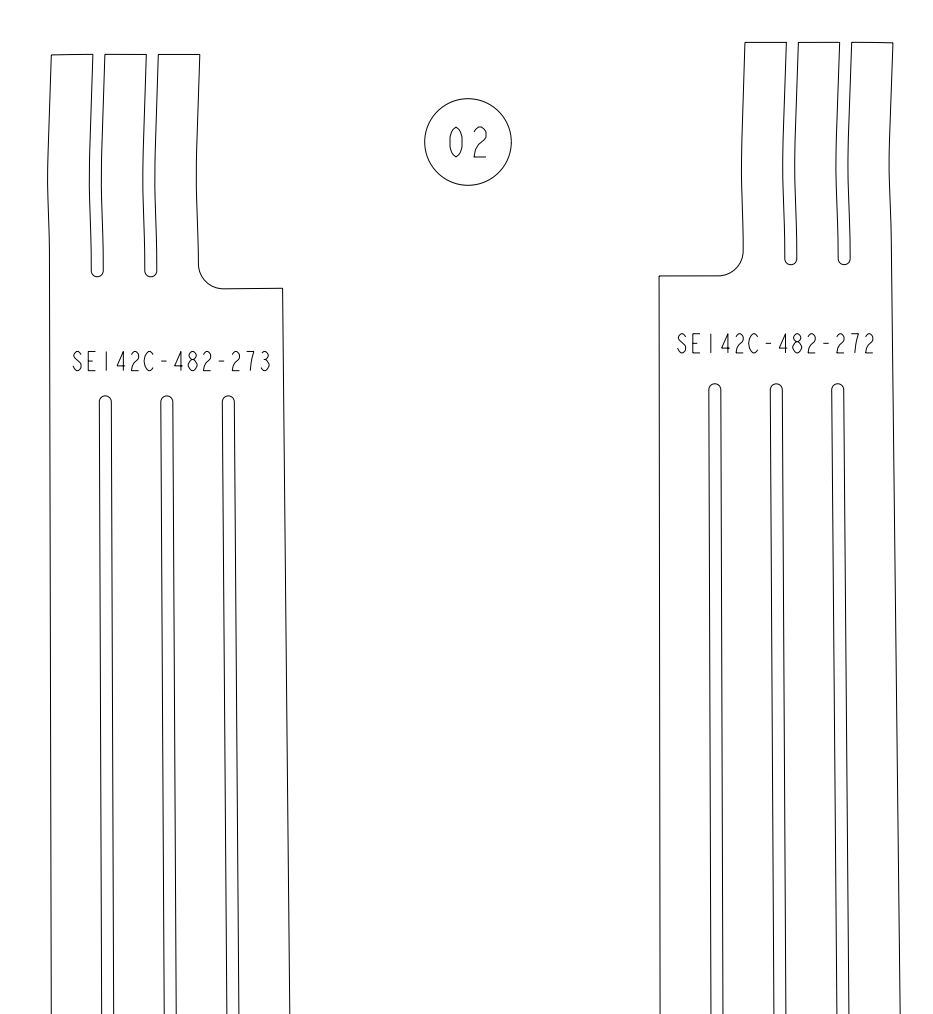

INSTANCE: SEI42C-482_FLAT_273
INSTANCE: SEI42C-482_FLAT_272

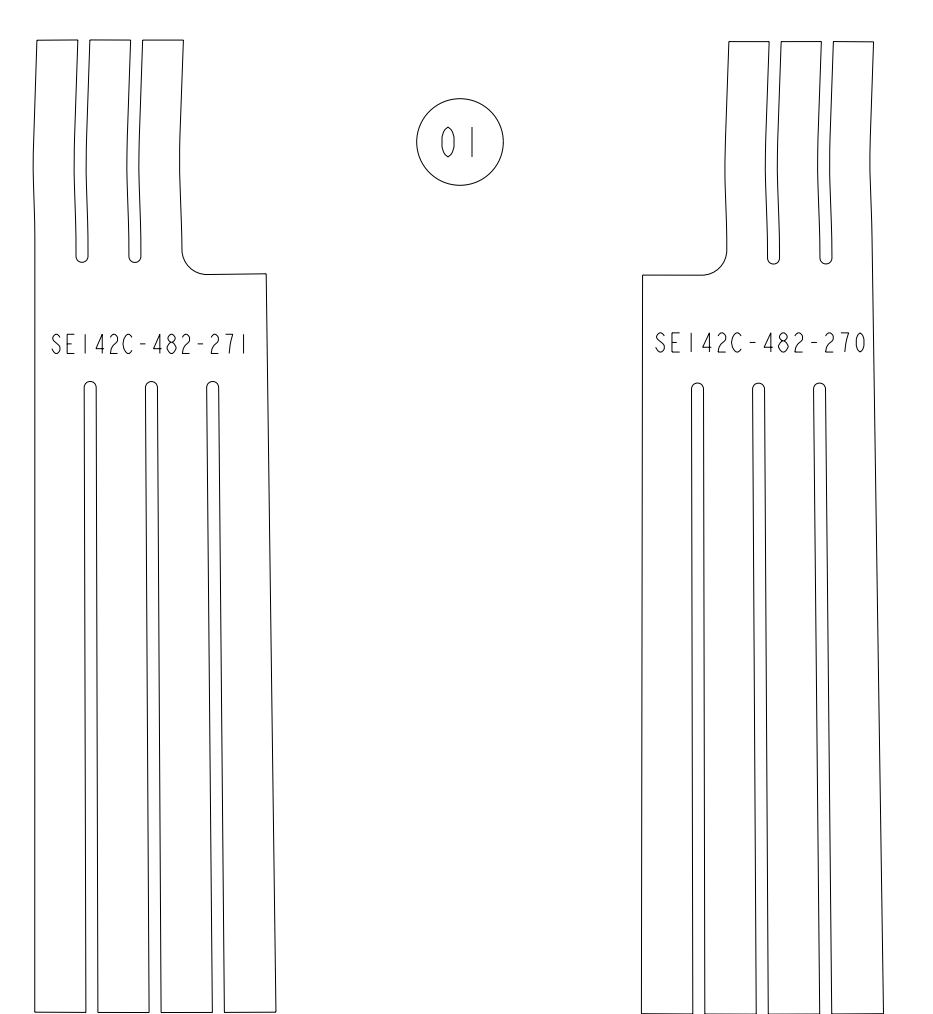

INSTANCE: SEI42C-482_FLAT_271
INSTANCE: SEI42C-482_FLAT_270

THESE PARTS TO BE NEMA GRADE GIICR MATERIAL

SCALE ALL VIEWS: 1.00

RELEASED FOR FABRICATION / INSTALLATION
PPPL Drafting:

Oak Ridge National Laboratory managed for the DEPARTMENT OF ENERGY under U.S. GOVERNMENT CONTRACT DE-AC05-00OR22725 UT-BATTELLE, LLC. Oak Ridge, Tennessee PROJECT NAME:									
NATIONAL COMPACT STELLARATOR EXPERIMENT MODULAR COIL TYPE - C SIDE -B UPPER CLADDING FLAT PATTERN LAYOUT									
VERSION NO.	PLANT	BLDG	FL	SHT	OF	TYPE	CLASS		
3	X-10	5700	3	2	5	S	U		
RELEASE LEVEL		SEI42C-482							
Fabrication									



8

7

6

5

4

3

2

1

NEXT ASS'Y:

FINAL ASS'Y:

INSTANCE:
SEI42C-482_FLAT_173

INSTANCE:
SEI42C-482_FLAT_172

INSTANCE:
SEI42C-482_FLAT_171

INSTANCE:
SEI42C-482_FLAT_170

INSTANCE:
SEI42C-482_FLAT_169

INSTANCE:
SEI42C-482_FLAT_168

INSTANCE:
SEI42C-482_FLAT_167

INSTANCE:
SEI42C-482_FLAT_166

INSTANCE:
SEI42C-482_FLAT_165

INSTANCE:
SEI42C-482_FLAT_164

INSTANCE:
SEI42C-482_FLAT_163

INSTANCE:
SEI42C-482_FLAT_162

INSTANCE:
SEI42C-482_FLAT_161

INSTANCE:
SEI42C-482_FLAT_160

INSTANCE:
SEI42C-482_FLAT_159

INSTANCE:
SEI42C-482_FLAT_158

INSTANCE:
SEI42C-482_FLAT_157

INSTANCE:
SEI42C-482_FLAT_156

INSTANCE:
SEI42C-482_FLAT_155

INSTANCE:
SEI42C-482_FLAT_154

INSTANCE:
SEI42C-482_FLAT_153

INSTANCE:
SEI42C-482_FLAT_152

INSTANCE:
SEI42C-482_FLAT_151

INSTANCE:
SEI42C-482_FLAT_150

INSTANCE:
SEI42C-482_FLAT_149

INSTANCE:
SEI42C-482_FLAT_148

INSTANCE:
SEI42C-482_FLAT_147

INSTANCE:
SEI42C-482_FLAT_146-NEW

INSTANCE:
SEI42C-482_FLAT_145-NEW

INSTANCE:
SEI42C-482_FLAT_144-NEW

INSTANCE:
SEI42C-482_FLAT_143-NEW

INSTANCE:
SEI42C-482_FLAT_142

INSTANCE:
SEI42C-482_FLAT_141

INSTANCE:
SEI42C-482_FLAT_140

INSTANCE:
SEI42C-482_FLAT_139

INSTANCE:
SEI42C-482_FLAT_138

INSTANCE:
SEI42C-482_FLAT_137

INSTANCE:
SEI42C-482_FLAT_136

INSTANCE:
SEI42C-482_FLAT_135

INSTANCE:
SEI42C-482_FLAT_134

INSTANCE:
SEI42C-482_FLAT_133

INSTANCE:
SEI42C-482_FLAT_132

INSTANCE:
SEI42C-482_FLAT_131

INSTANCE:
SEI42C-482_FLAT_130

INSTANCE:
SEI42C-482_FLAT_129

INSTANCE:
SEI42C-482_FLAT_128

INSTANCE:
SEI42C-482_FLAT_127

INSTANCE:
SEI42C-482_FLAT_126

SCALE ALL VIEWS: 1.00

**RELEASED FOR
FABRICATION / INSTALLATION**
PPPL Drafting:

Oak Ridge National Laboratory managed for the DEPARTMENT OF ENERGY under U.S. GOVERNMENT CONTRACT DE-AC05-00OR22725 UT-BATTELLE, LLC, Oak Ridge, Tennessee PROJECT NAME:									
UT-BATTELLE									
NATIONAL COMPACT STELLARATOR EXPERIMENT									
MODULAR COIL TYPE - C									
SIDE -B UPPER CLADDING									
FLAT PATTERN LAYOUT									
VERSION NO.	PLANT	BLDG	FL	SHT	OF	TYPE	CLASS		
3	X-10	5700	3	3	5	S	U		
RELEASE LEVEL		SEI42C-482							
Fabrication									

8

7

6

5

4

3

2

1

SEI42C-482

A



SCALE ALL VIEWS: 1.00

**RELEASED FOR
FABRICATION / INSTALLATION**
PPPL Drafting

Oak Ridge National Laboratory managed for the DEPARTMENT OF ENERGY under U.S. GOVERNMENT contract DE-AC05-00OR22725 UT-BATTELLE, LLC, Oak Ridge, Tennessee PROJECT NAME					
UT-BATTELLE NATIONAL COMPACT STELLARATOR EXPERIMENT MODULAR COIL TYPE - C SIDE -B UPPER CLADDING FLAT PATTERN LAYOUT					
VERSION NO.	PLANT	BLDG	FL	SHT	OF
3	X-10	5700	3	4	5
RELEASE LEVEL	SE142C-482				CLASS
Fabrication					U
					REV
					1

SE142C-482

1

THESE PARTS TO BE NEMA GRADE GIICR MATERIAL

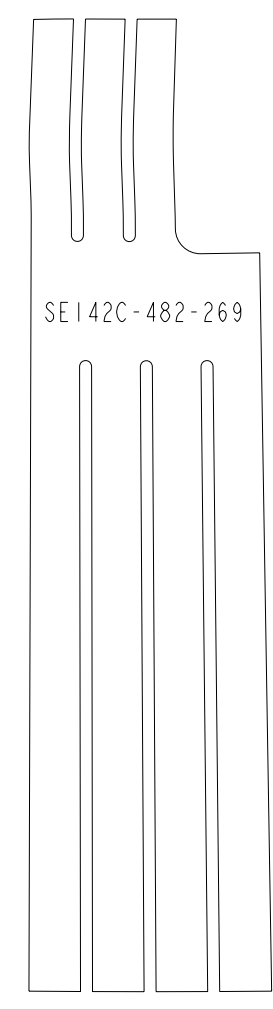

96

INSTANCE:
SE142C-482_FLAT_269

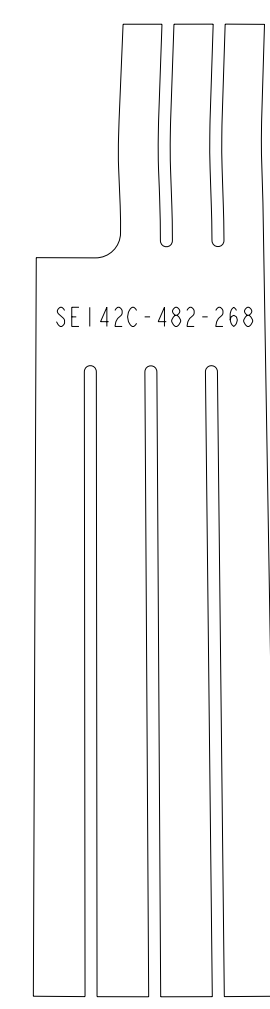

INSTANCE:
SE142C-482_FLAT_268

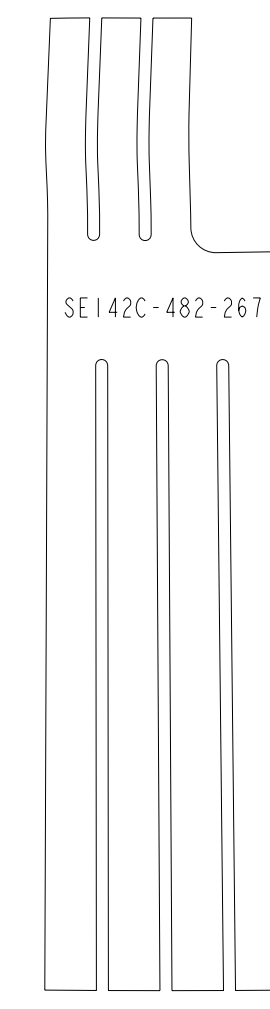

INSTANCE:
SE142C-482_FLAT_267

95

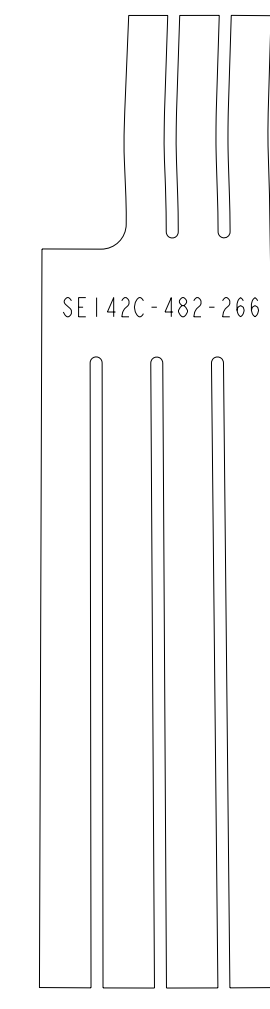

INSTANCE:
SE142C-482_FLAT_266

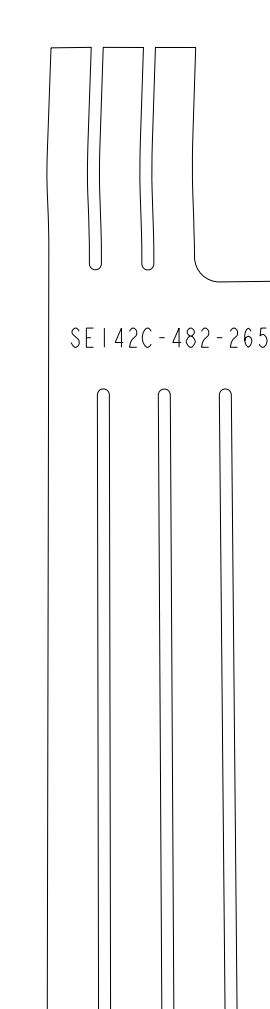

INSTANCE:
SE142C-482_FLAT_265

94

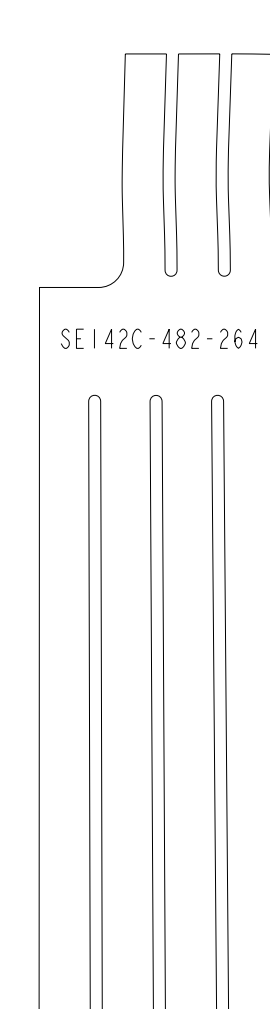

INSTANCE:
SE142C-482_FLAT_264

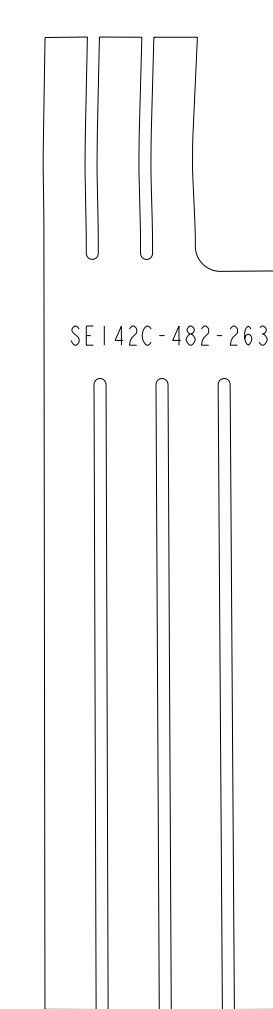

INSTANCE:
SE142C-482_FLAT_263

93

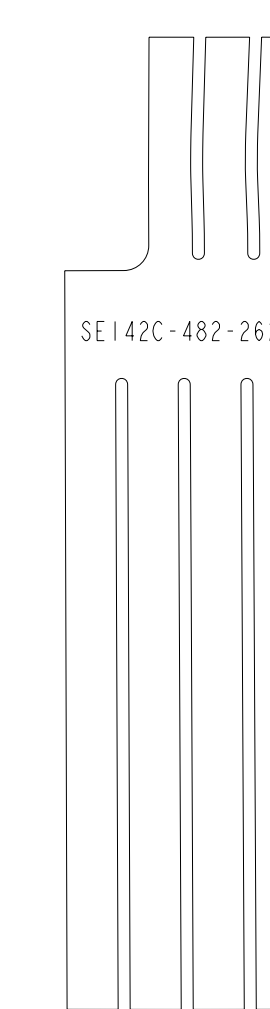

INSTANCE:
SE142C-482_FLAT_262

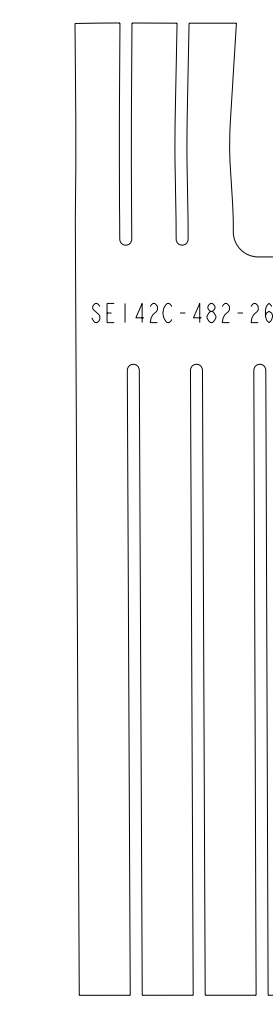

INSTANCE:
SE142C-482_FLAT_261

92

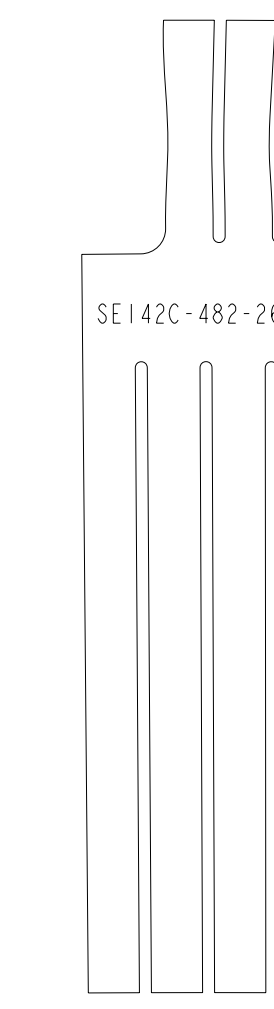

INSTANCE:
SE142C-482_FLAT_260

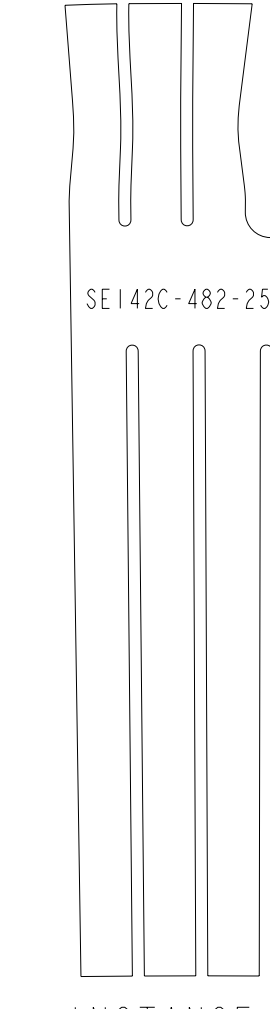

INSTANCE:
SE142C-482_FLAT_259

91

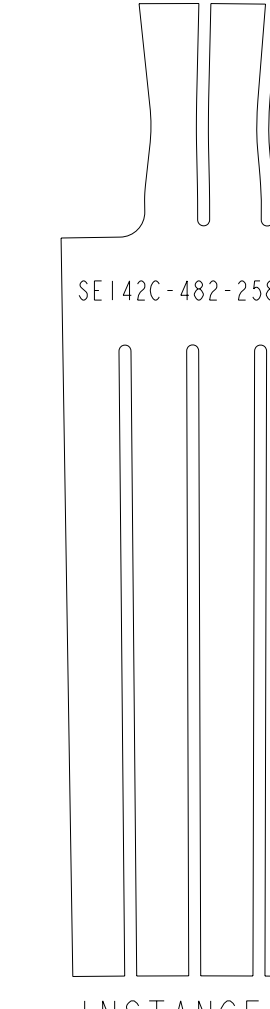

INSTANCE:
SE142C-482_FLAT_258

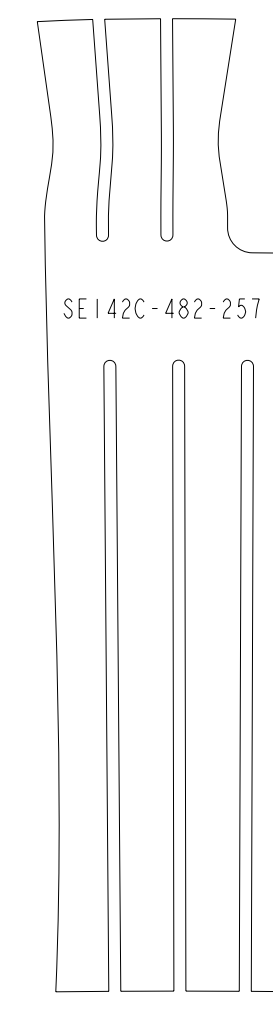

90

INSTANCE:
SE142C-482_FLAT_257

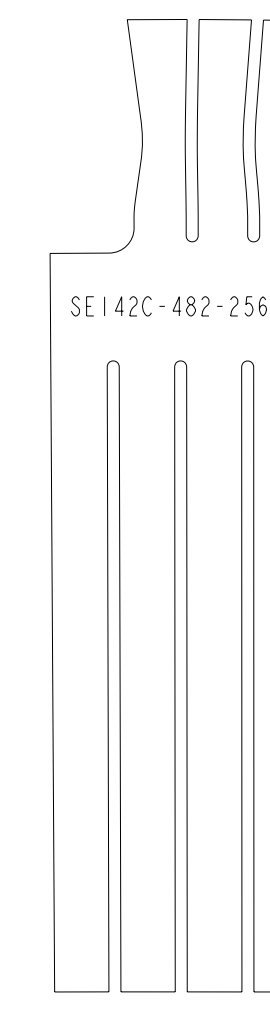

INSTANCE:
SE142C-482_FLAT_256

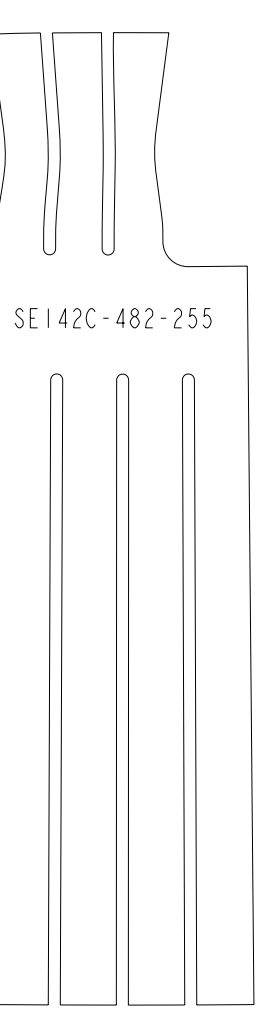

INSTANCE:
SE142C-482_FLAT_255

89

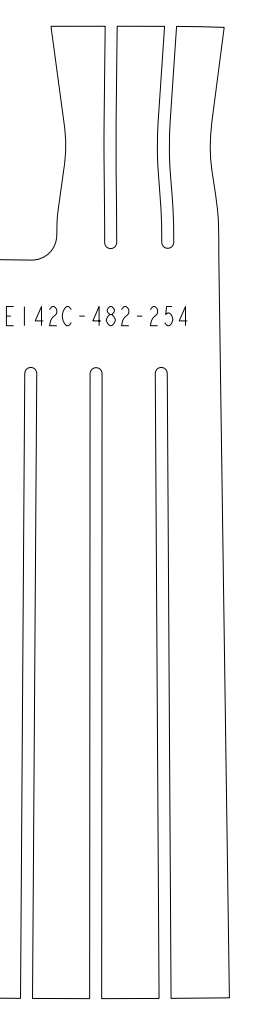

INSTANCE:
SE142C-482_FLAT_254

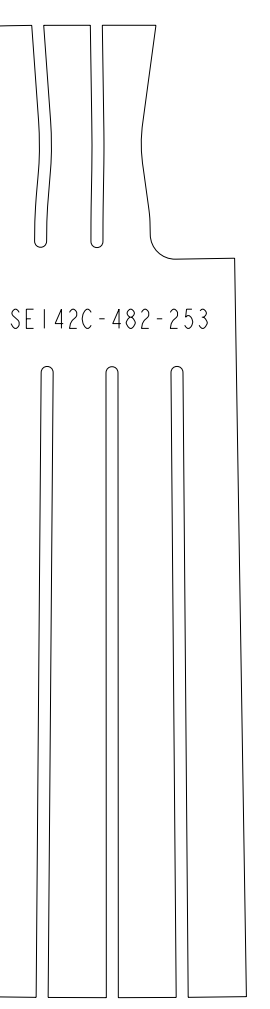

INSTANCE:
SE142C-482_FLAT_253

88

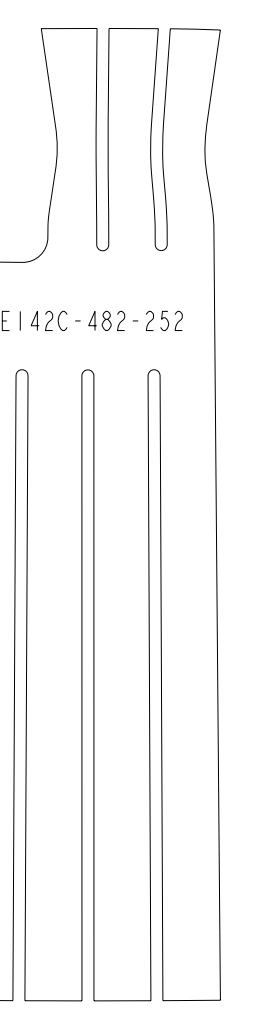

INSTANCE:
SE142C-482_FLAT_252

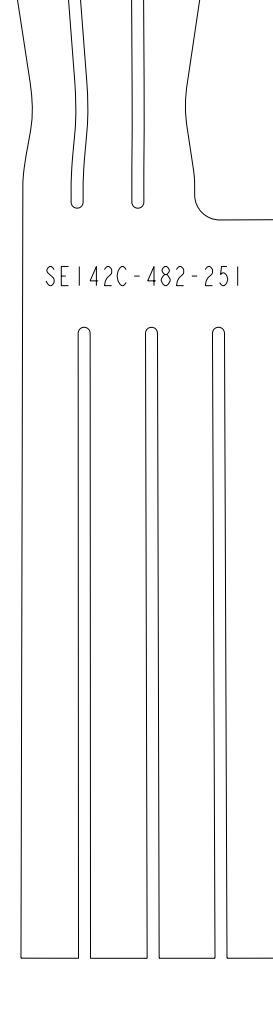

INSTANCE:
SE142C-482_FLAT_251

87

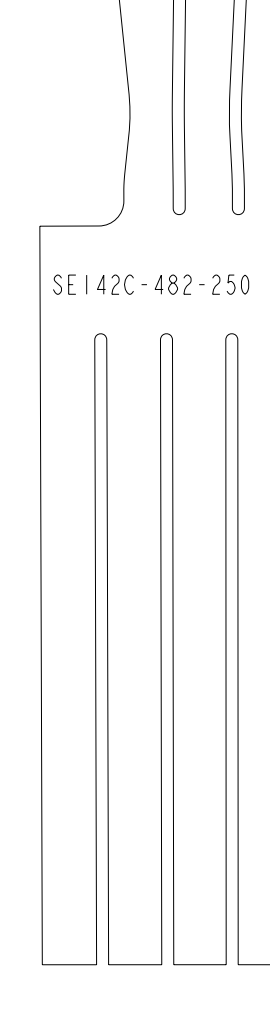

INSTANCE:
SE142C-482_FLAT_250

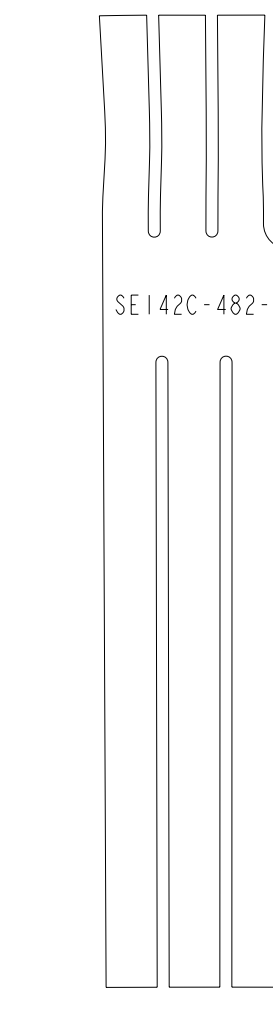

INSTANCE:
SE142C-482_FLAT_249

86

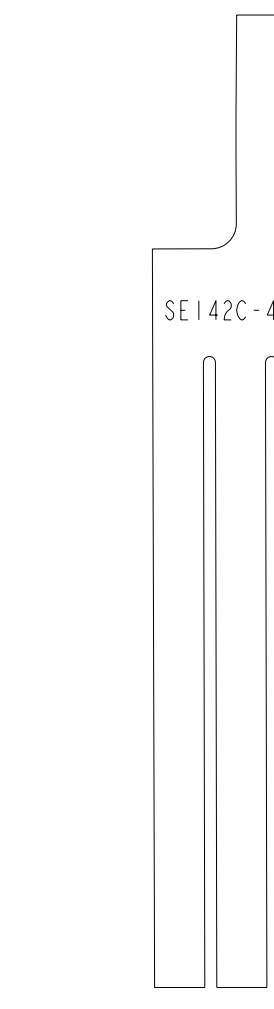

INSTANCE:
SE142C-482_FLAT_248

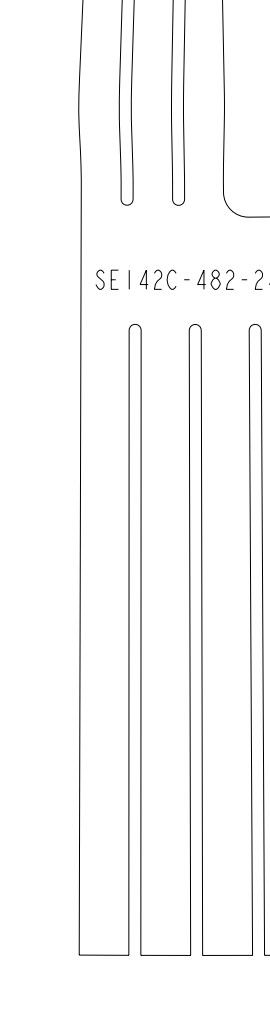

INSTANCE:
SE142C-482_FLAT_247

85

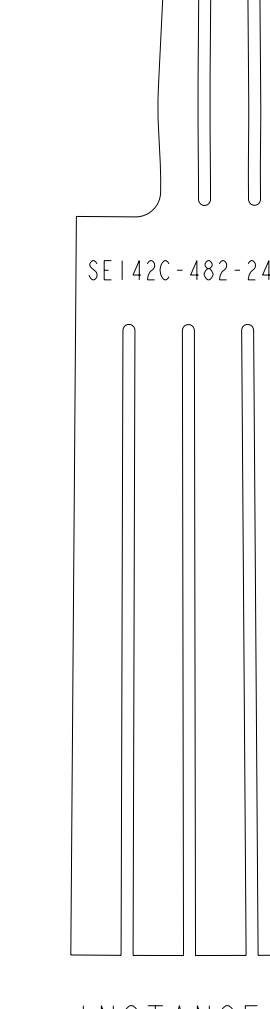

INSTANCE:
SE142C-482_FLAT_246

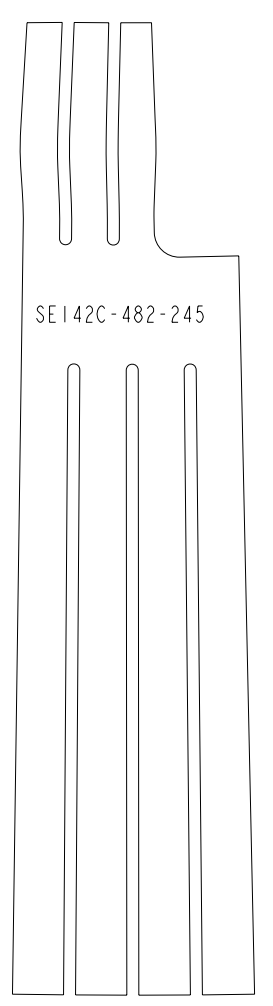

84

INSTANCE:
SE142C-482_FLAT_245

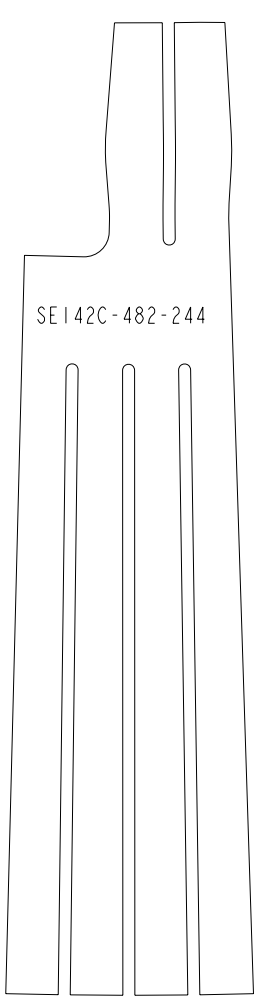

INSTANCE:
SE142C-482_FLAT_244-NEW

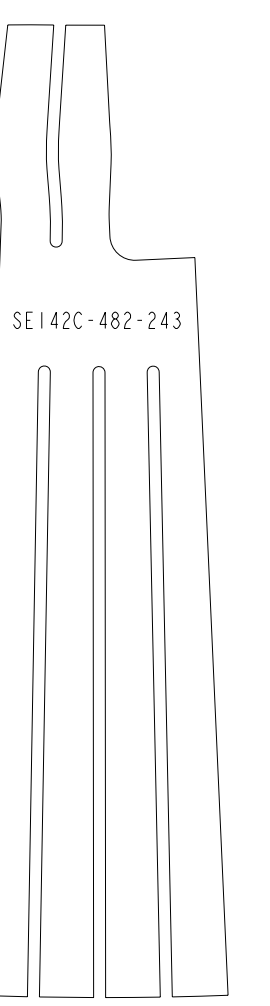

INSTANCE:
SE142C-482_FLAT_243-NEW

83

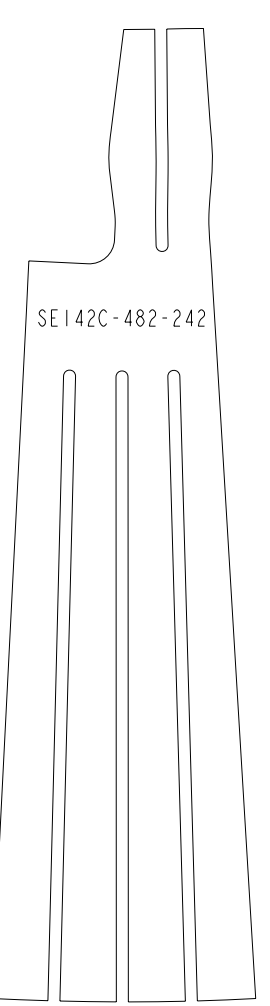

INSTANCE:
SE142C-482_FLAT_242-NEW

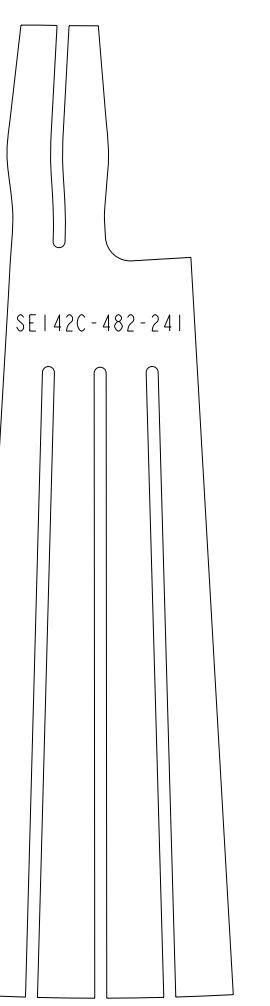

INSTANCE:
SE142C-482_FLAT_241-NEW

82

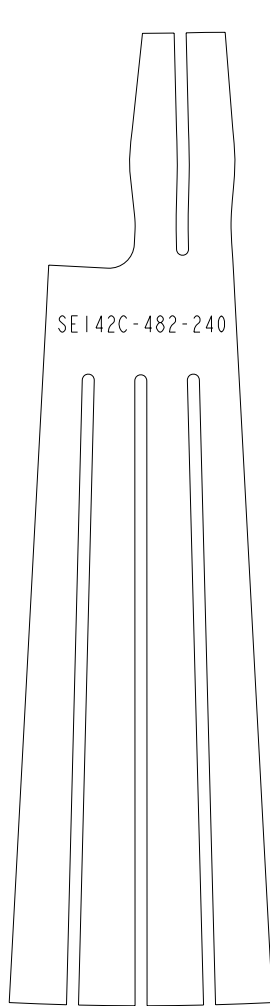

INSTANCE:
SE142C-482_FLAT_240-NEW

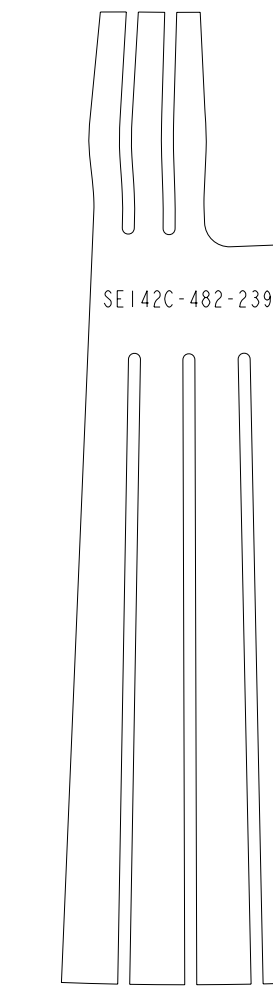

INSTANCE:
SE142C-482_FLAT_239

81

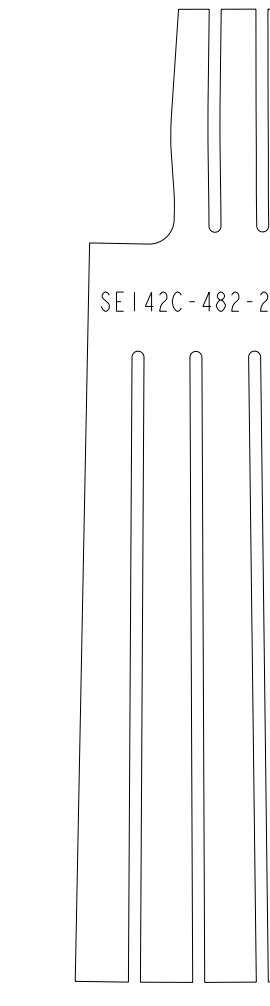

INSTANCE:
SE142C-482_FLAT_238

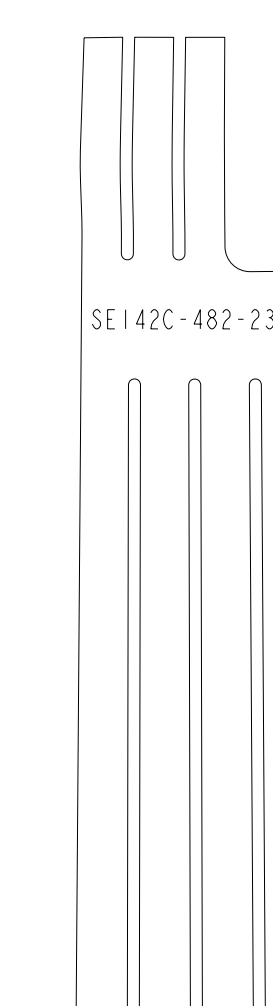

INSTANCE:
SE142C-482_FLAT_237

80

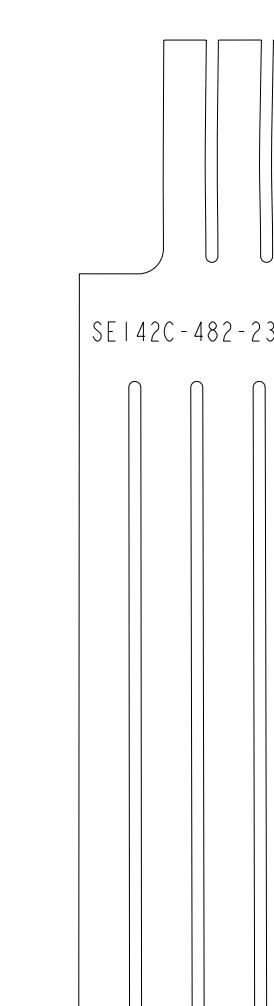

INSTANCE:
SE142C-482_FLAT_236

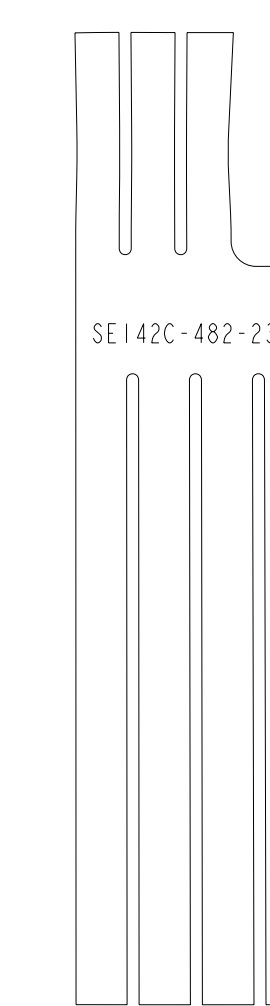

INSTANCE:
SE142C-482_FLAT_235

79

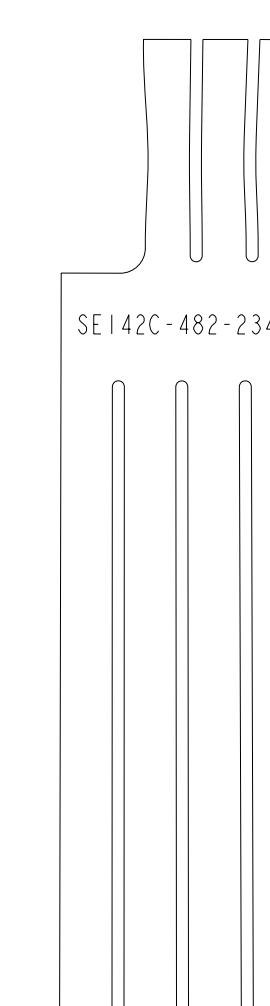

INSTANCE:
SE142C-482_FLAT_234

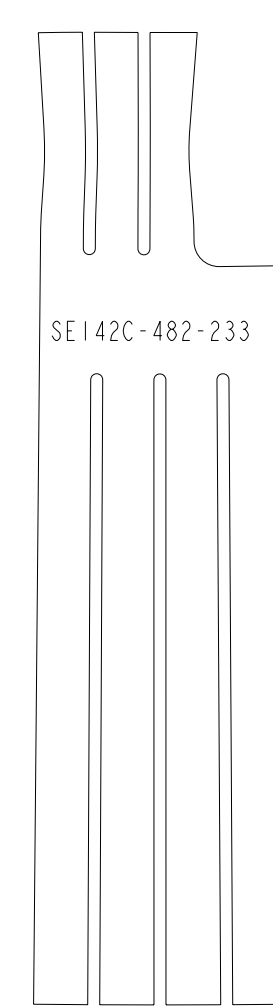

78

INSTANCE:
SE142C-482_FLAT_233

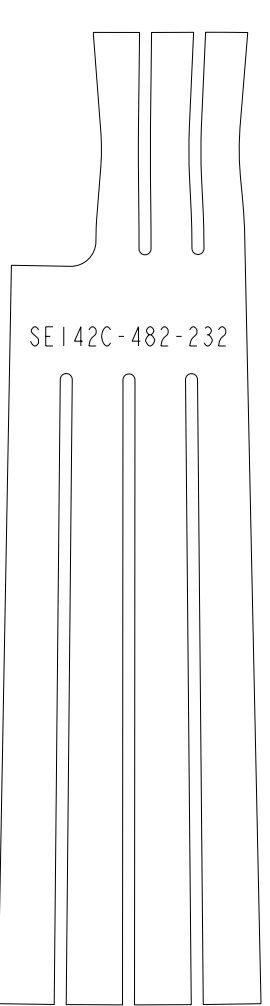

INSTANCE:
SE142C-482_FLAT_232

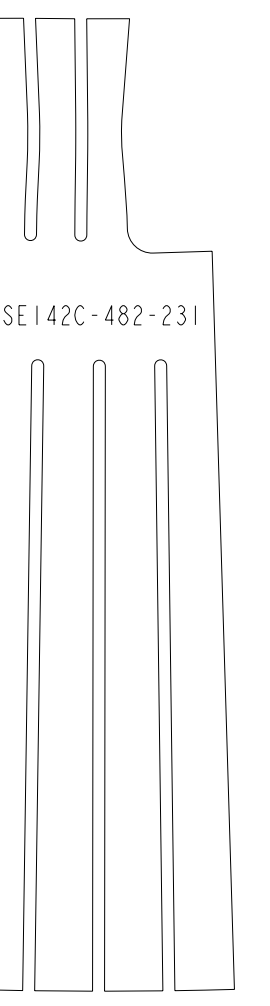

INSTANCE:
SE142C-482_FLAT_231

77

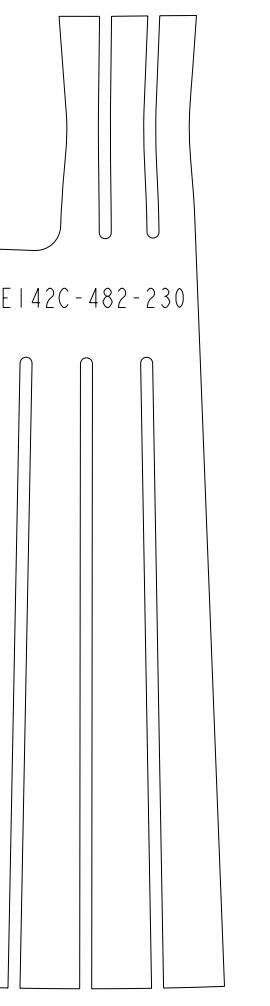

INSTANCE:
SE142C-482_FLAT_230

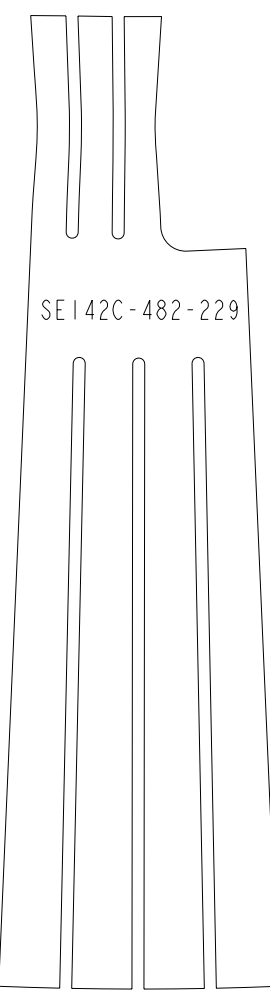

INSTANCE:
SE142C-482_FLAT_229

76

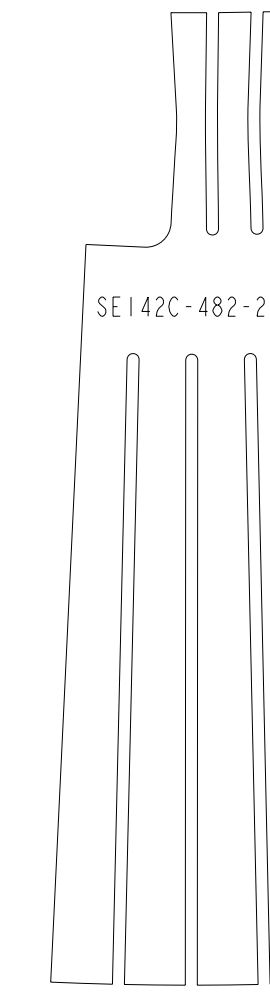

INSTANCE:
SE142C-482_FLAT_228

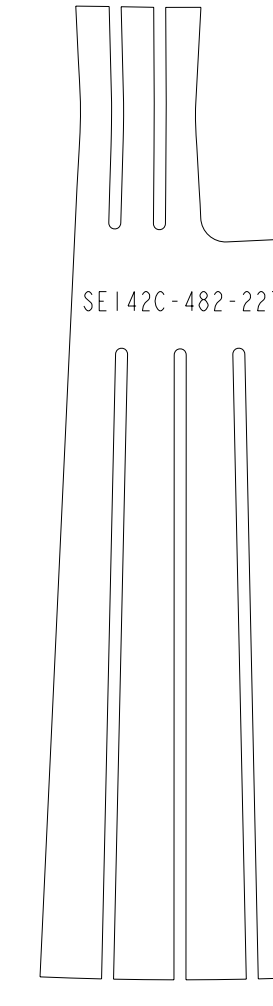

INSTANCE:
SE142C-482_FLAT_227

75

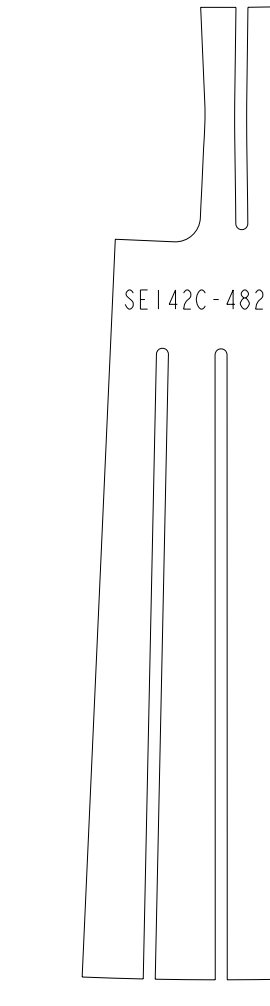

INSTANCE:
SE142C-482_FLAT_226

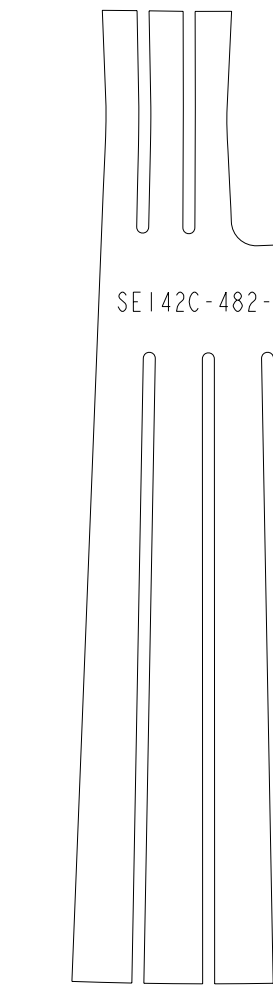

INSTANCE:
SE142C-482_FLAT_225

74

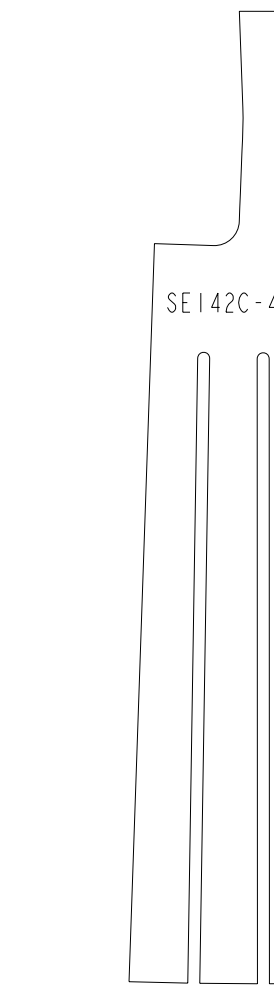

INSTANCE:
SE142C-482_FLAT_224

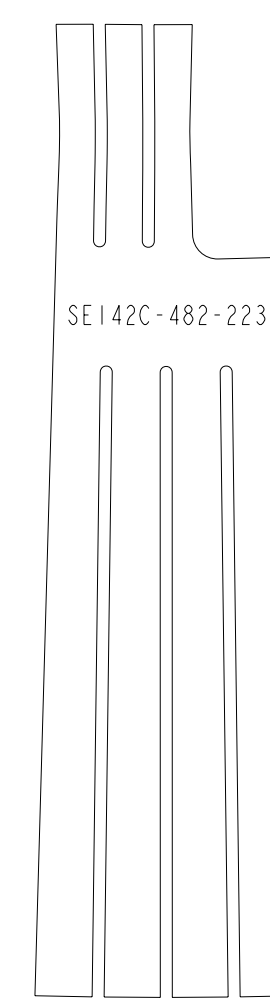

INSTANCE:
SE142C-482_FLAT_223

73

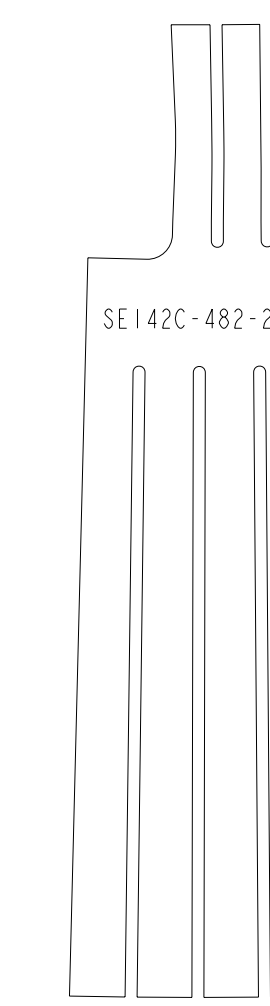

INSTANCE:
SE142C-482_FLAT_222

SCALE ALL VIEWS: 1:00
RELEASED FOR FABRICATION / INSTALLATION
PPPL Drafting

Oak Ridge National Laboratory managed for the DEPARTMENT OF ENERGY under U.S. GOVERNMENT CONTRACT DE-AC05-00OR22725 UT-BATTELLE, LLC., Oak Ridge, Tennessee PROJECT NAME:									
UT-BATTELLE NATIONAL COMPACT STELLARATOR EXPERIMENT MODULAR COIL TYPE - C SIDE -B UPPER CLADDING FLAT PATTERN LAYOUT									
VERSION NO.	PLANT	BLDG	FL	SHT	OF	TYPE	CLASS		
3	X-10	5700	3	5	5	S	U		
RELEASE LEVEL		SE142C-482							
Fabrication									