

8

7

6

5

4

3

2

1

NEXT ASS'Y: FINAL ASS'Y:

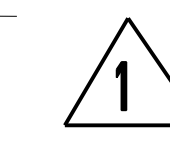

THESE PARTS TO BE NEMA GRADE GIICR MATERIAL

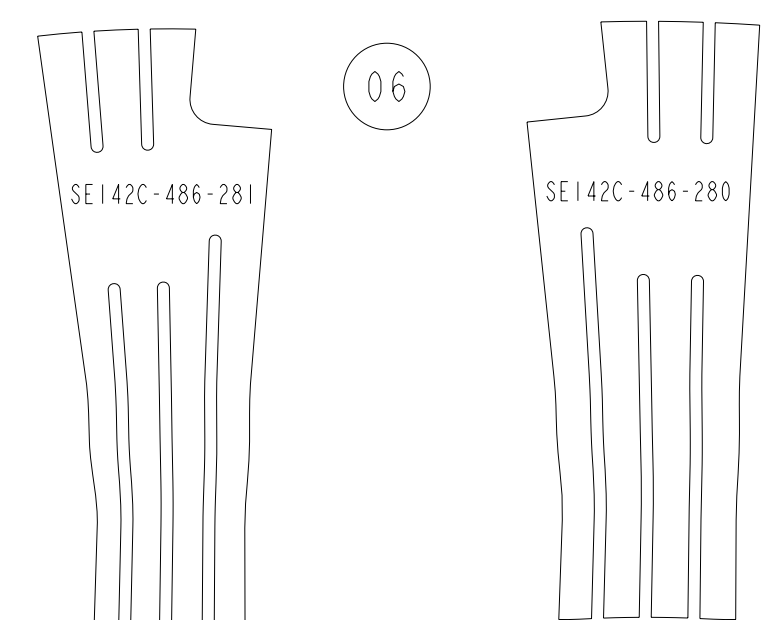

06

INSTANCE:
SE142C-486_FLAT_281

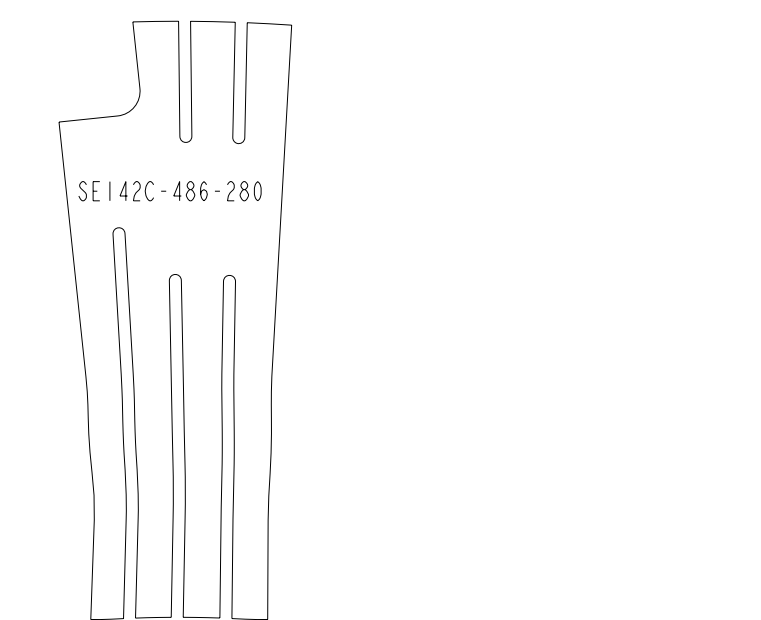

05

INSTANCE:
SE142C-486_FLAT_280

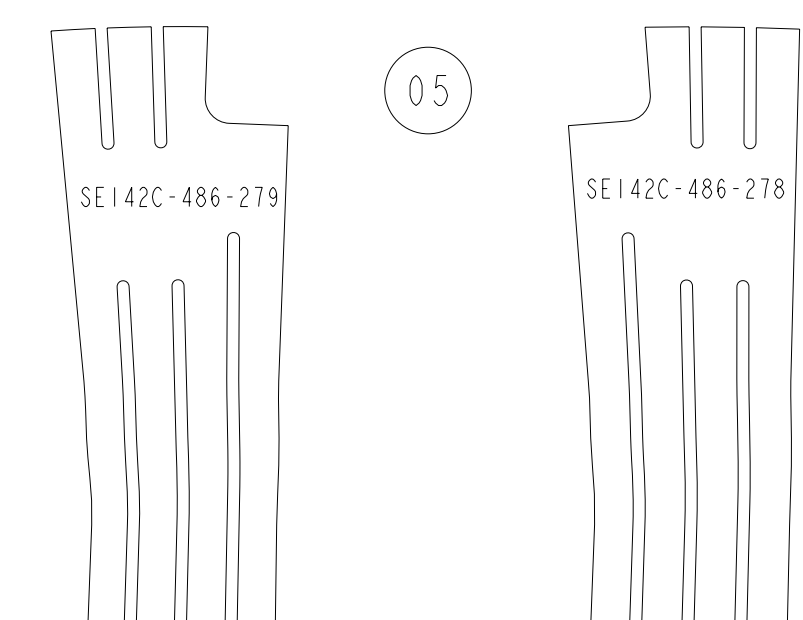

04

INSTANCE:
SE142C-486_FLAT_279

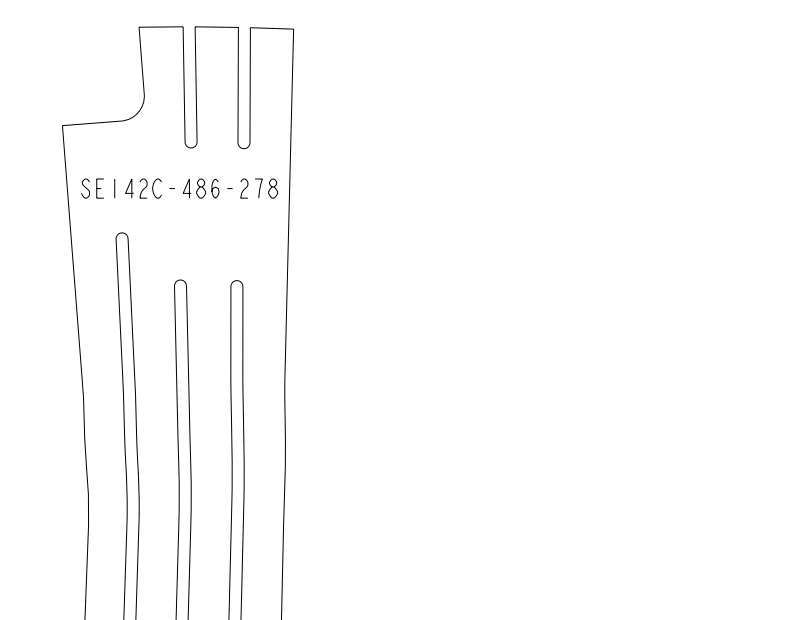

03

INSTANCE:
SE142C-486_FLAT_278

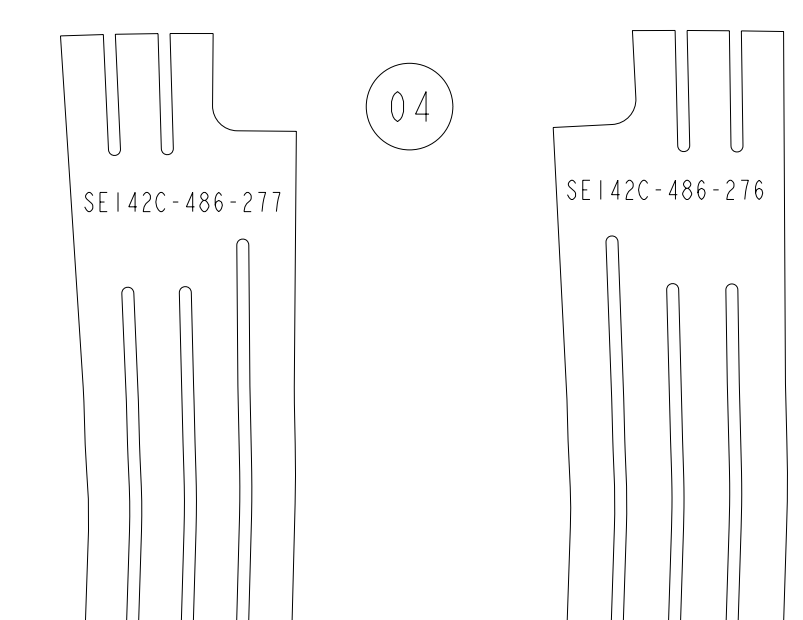

02

INSTANCE:
SE142C-486_FLAT_277

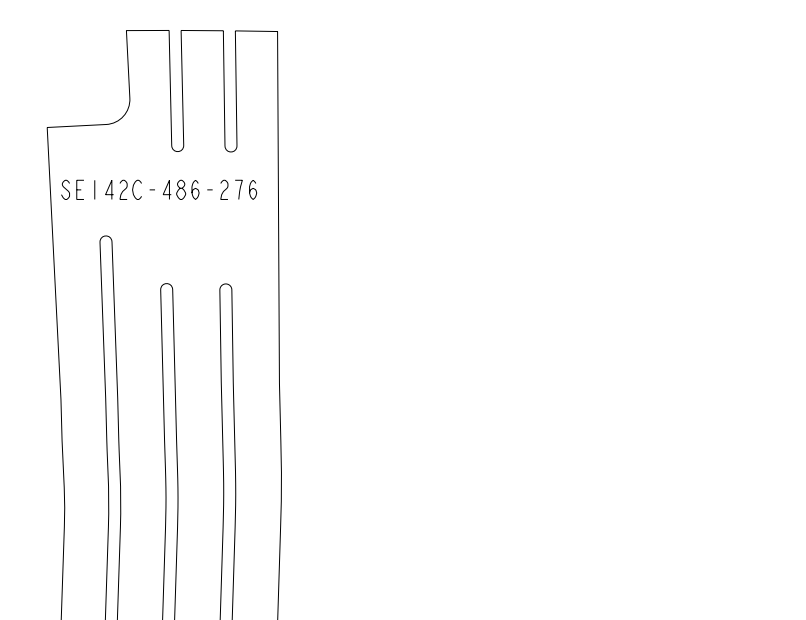

01

INSTANCE:
SE142C-486_FLAT_276

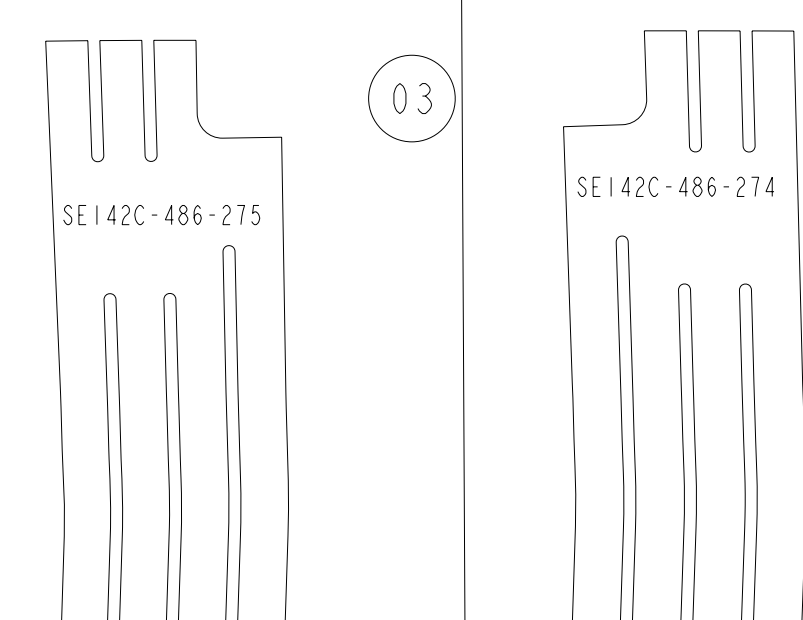

00

INSTANCE:
SE142C-486_FLAT_275

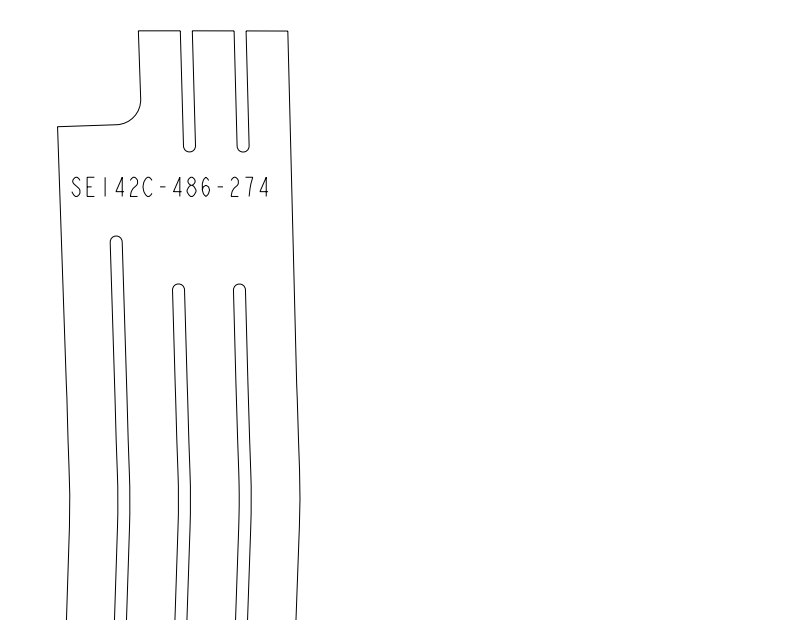

00

INSTANCE:
SE142C-486_FLAT_274

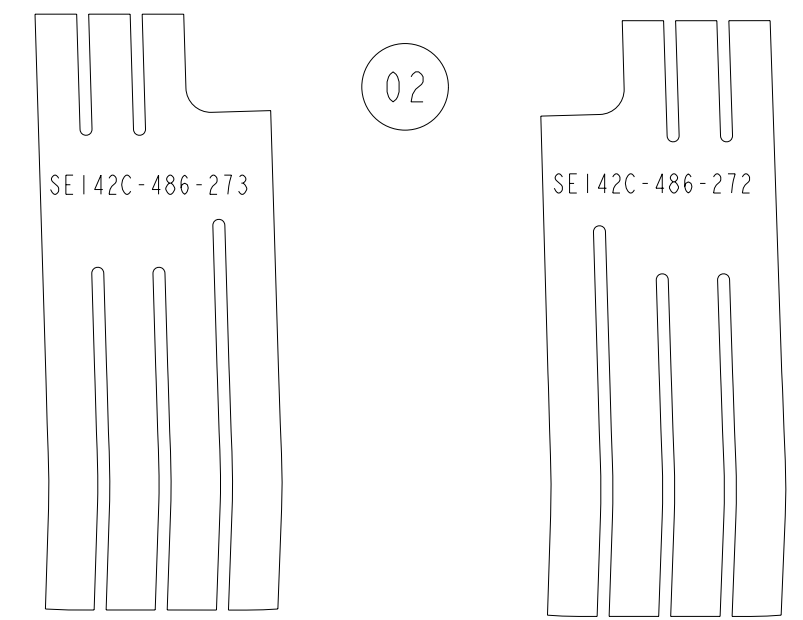

00

INSTANCE:
SE142C-486_FLAT_273

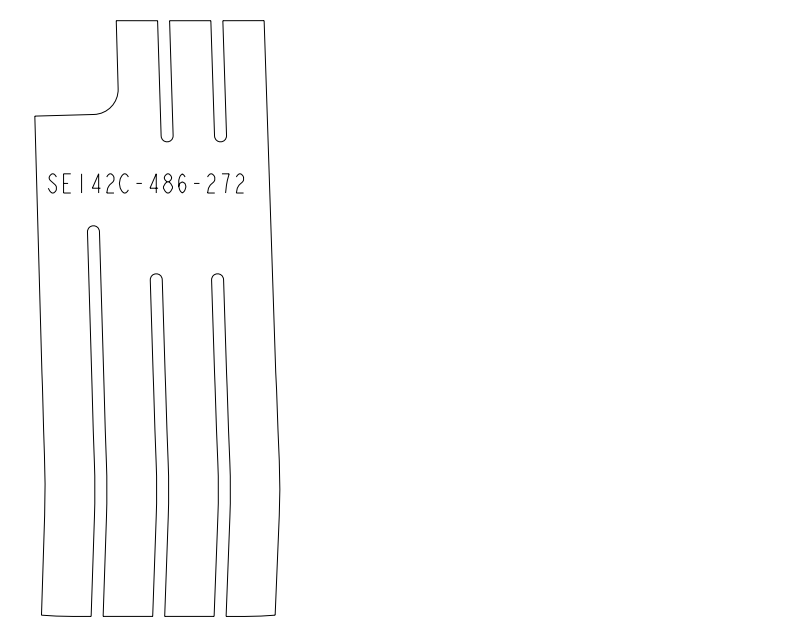

00

INSTANCE:
SE142C-486_FLAT_272

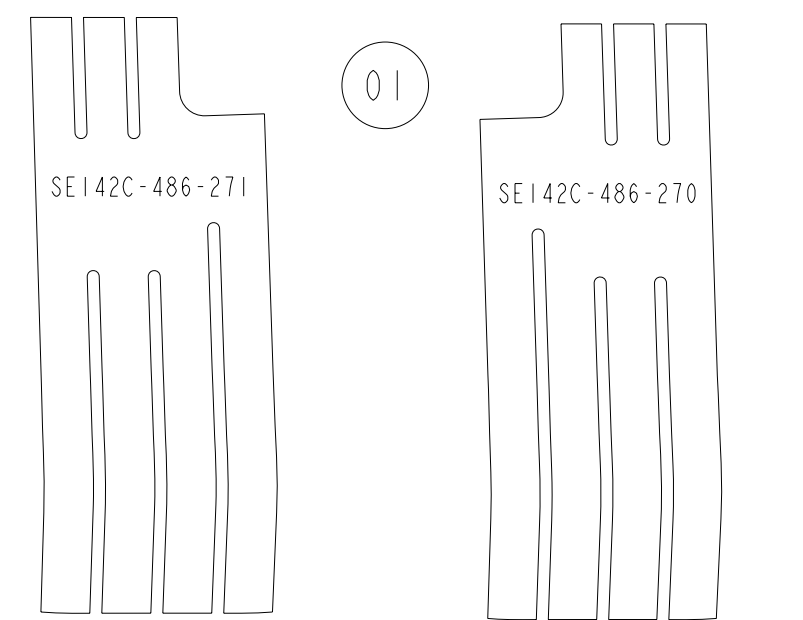

00

INSTANCE:
SE142C-486_FLAT_271

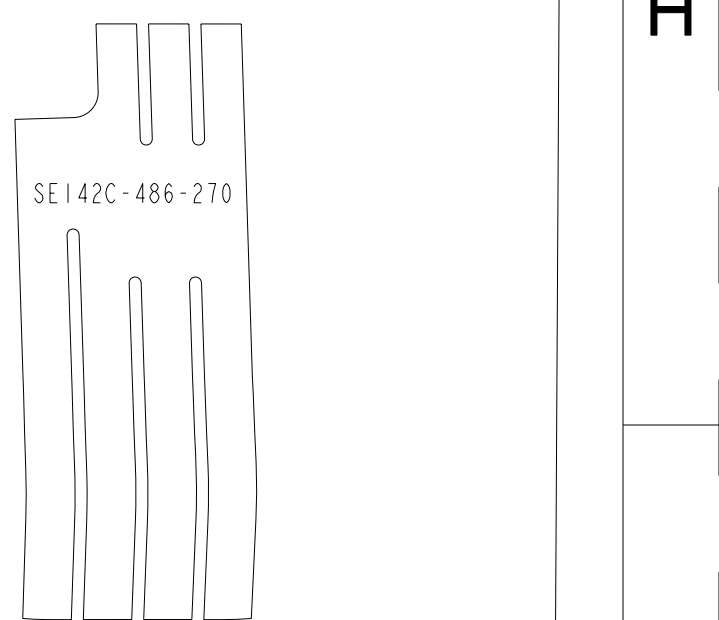

00

INSTANCE:
SE142C-486_FLAT_270

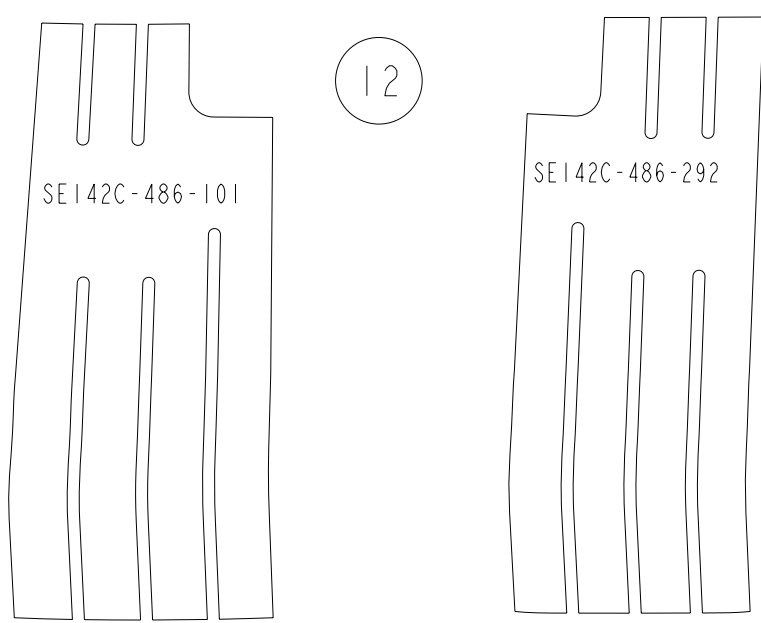

12

INSTANCE:
SE142C-486_FLAT_101

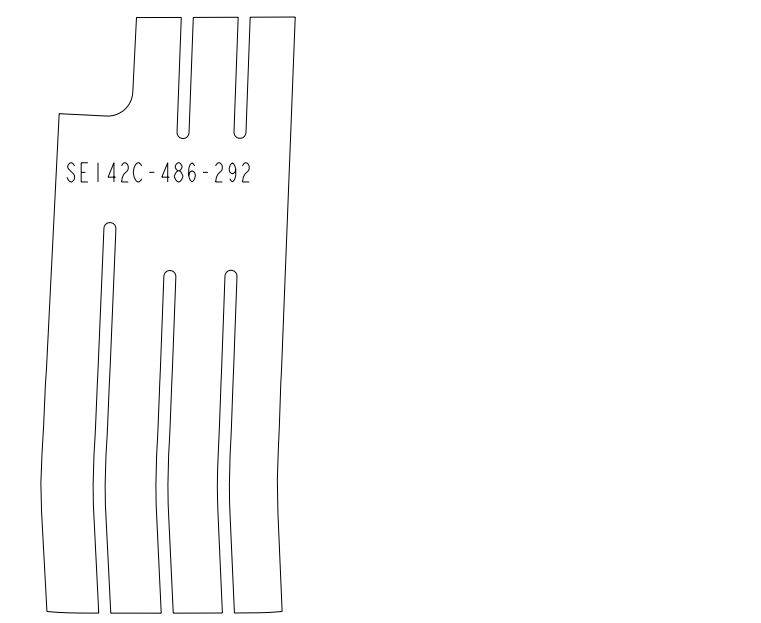

11

INSTANCE:
SE142C-486_FLAT_292-NEW

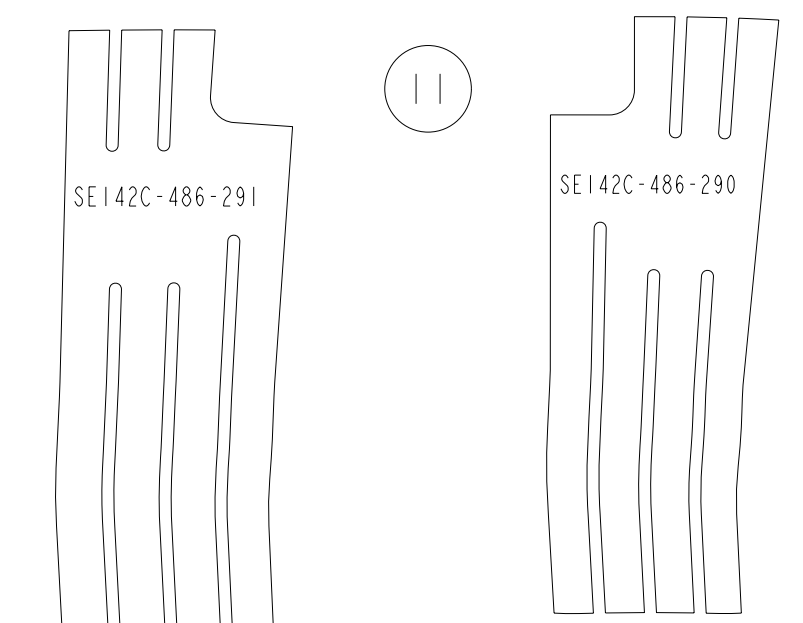

10

INSTANCE:
SE142C-486_FLAT_291

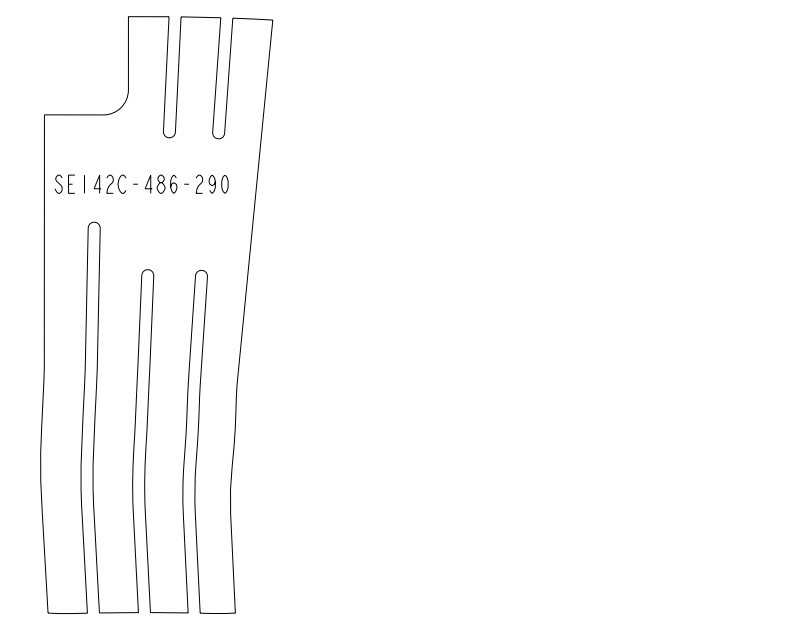

09

INSTANCE:
SE142C-486_FLAT_290

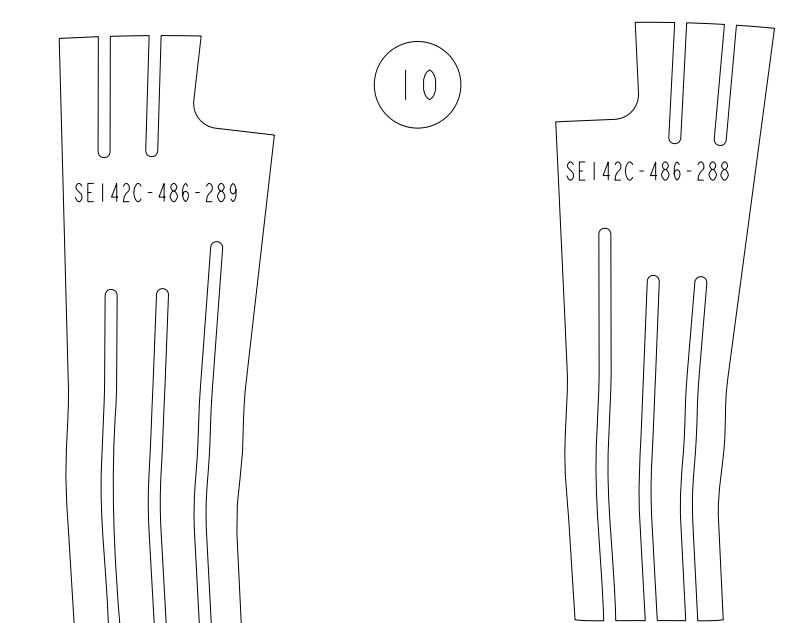

08

INSTANCE:
SE142C-486_FLAT_289

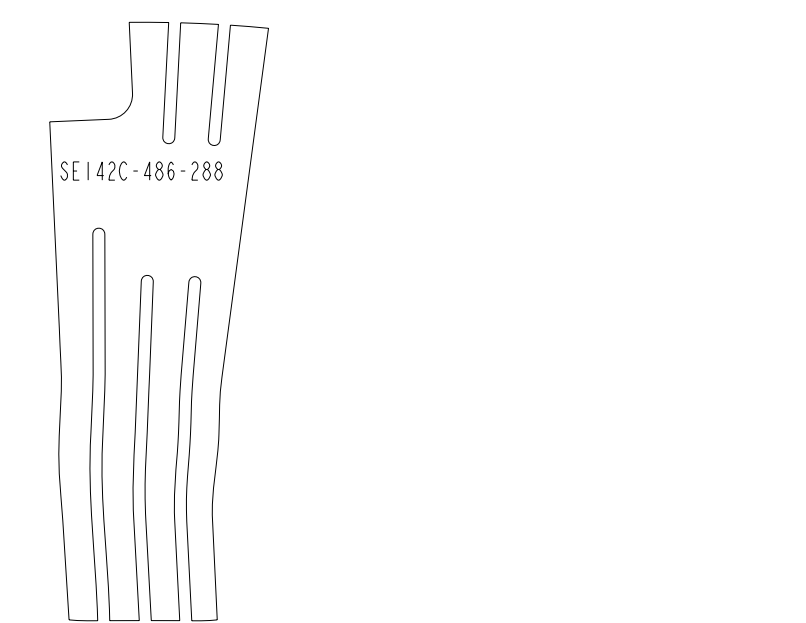

07

INSTANCE:
SE142C-486_FLAT_288

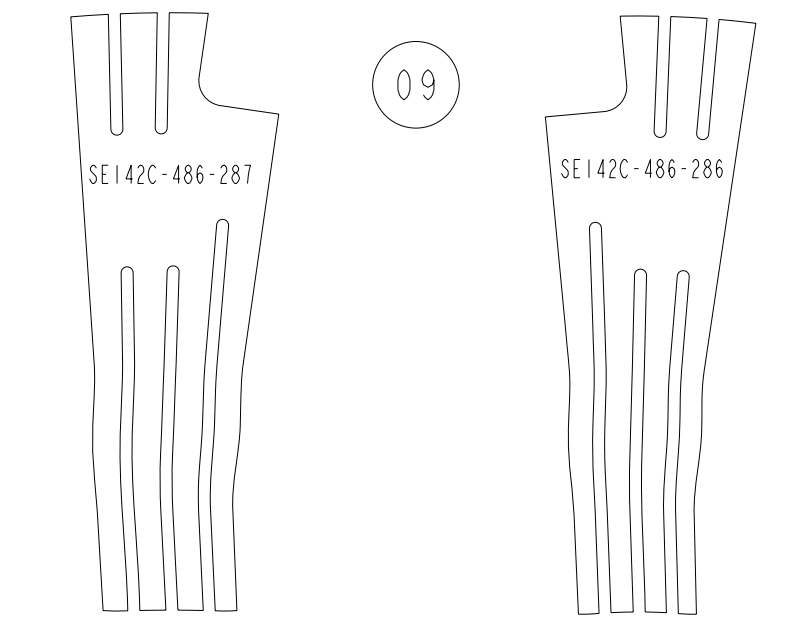

06

INSTANCE:
SE142C-486_FLAT_287

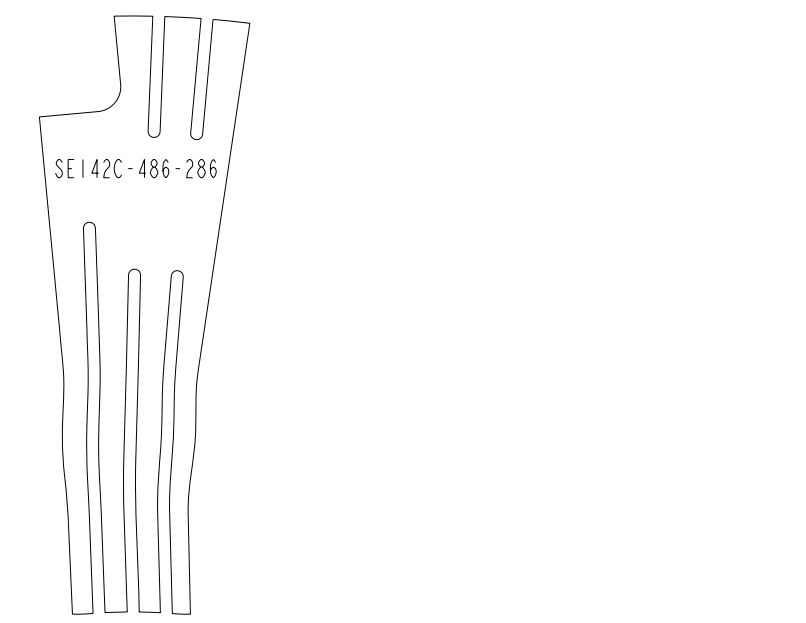

05

INSTANCE:
SE142C-486_FLAT_286

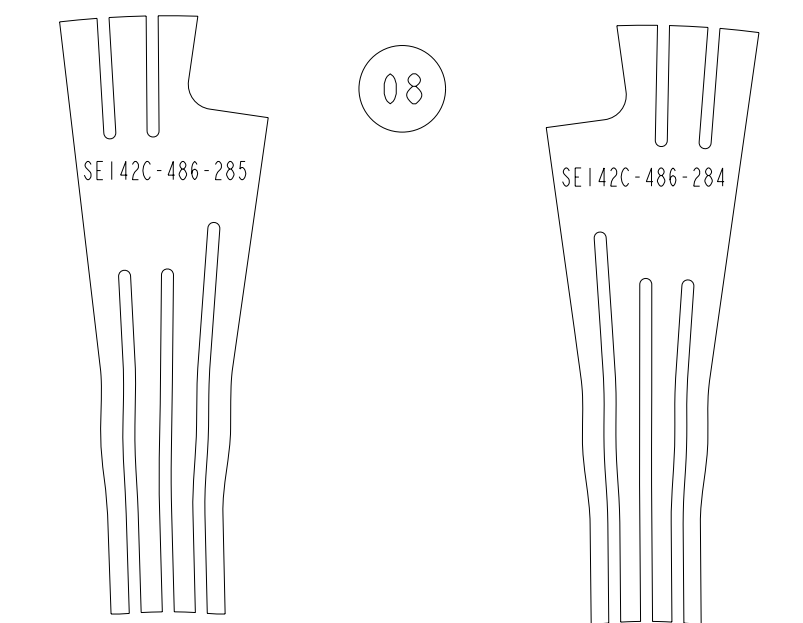

04

INSTANCE:
SE142C-486_FLAT_285

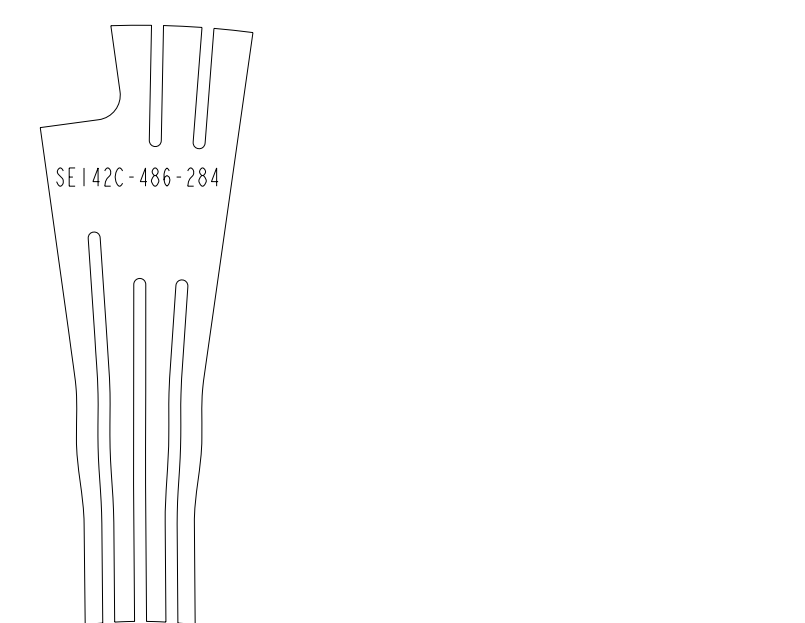

03

INSTANCE:
SE142C-486_FLAT_284

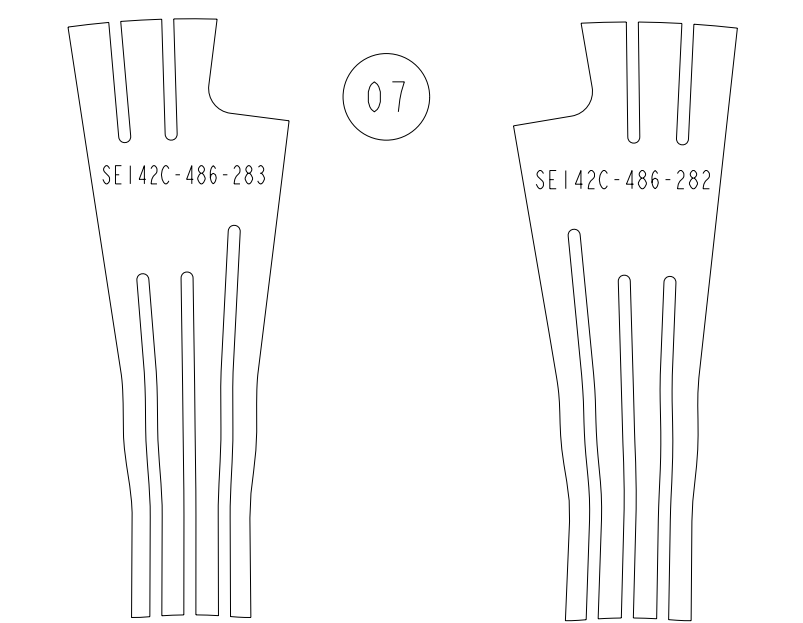

02

INSTANCE:
SE142C-486_FLAT_283

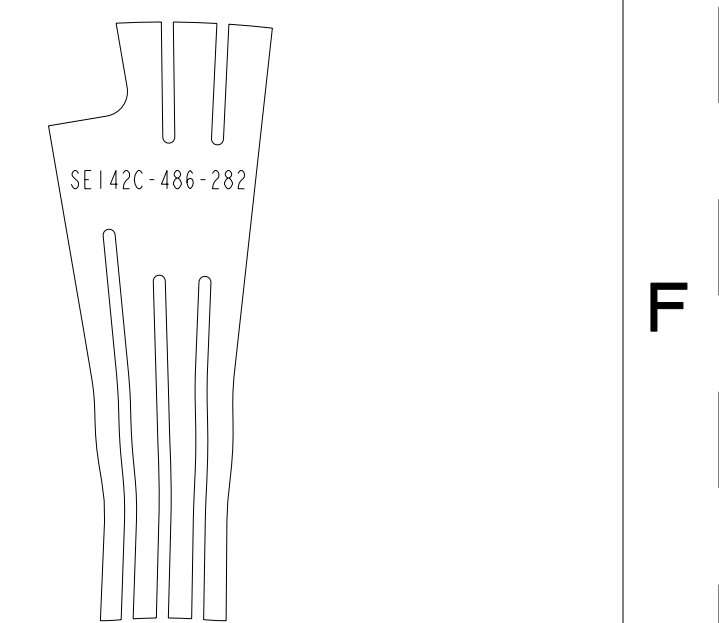

01

INSTANCE:
SE142C-486_FLAT_282

POLODIAL BREAK

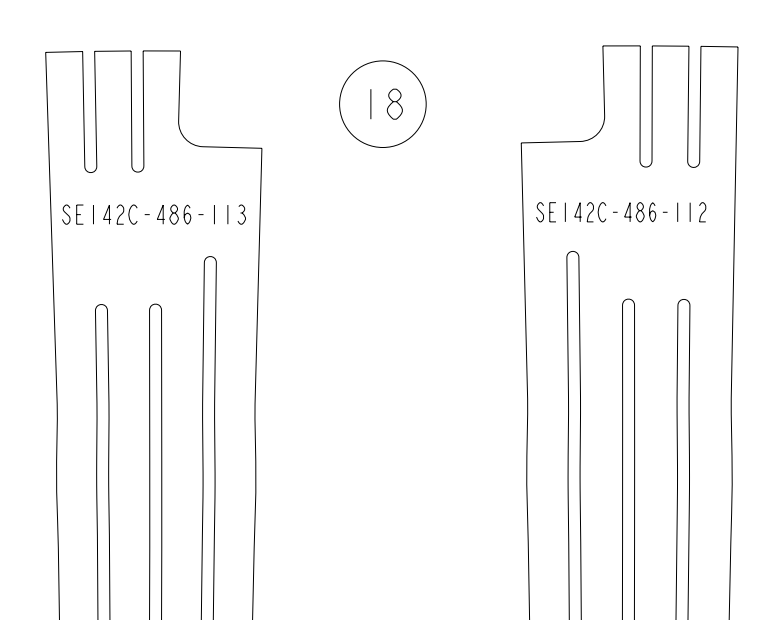

18

INSTANCE:
SE142C-486_FLAT_113

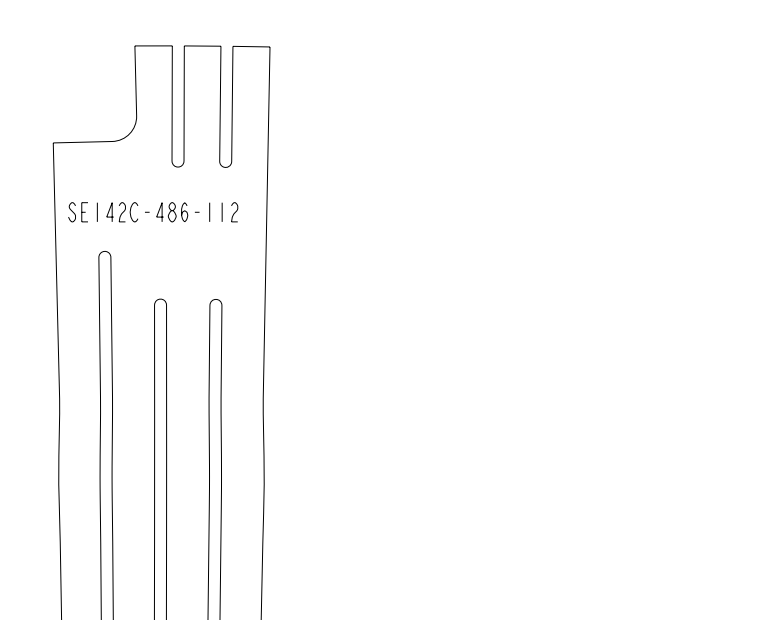

17

INSTANCE:
SE142C-486_FLAT_112

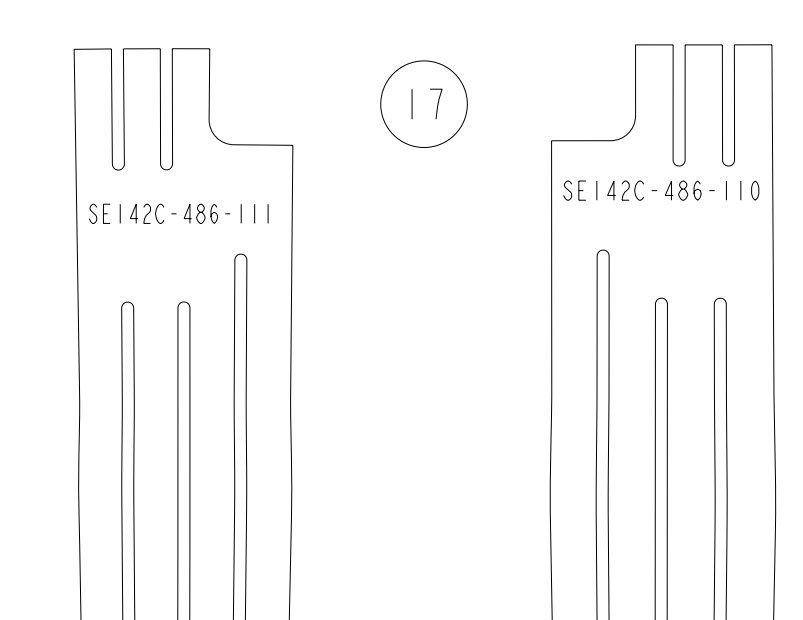

16

INSTANCE:
SE142C-486_FLAT_111

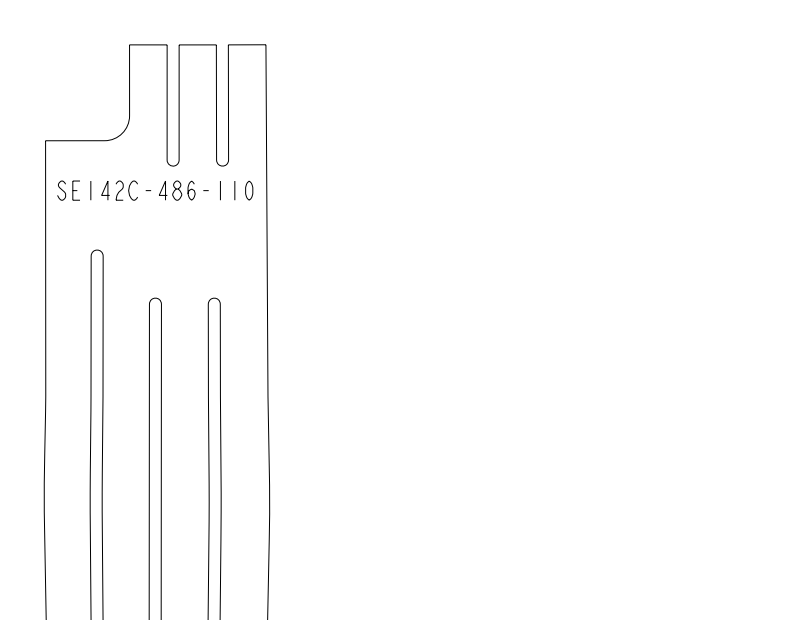

15

INSTANCE:
SE142C-486_FLAT_110

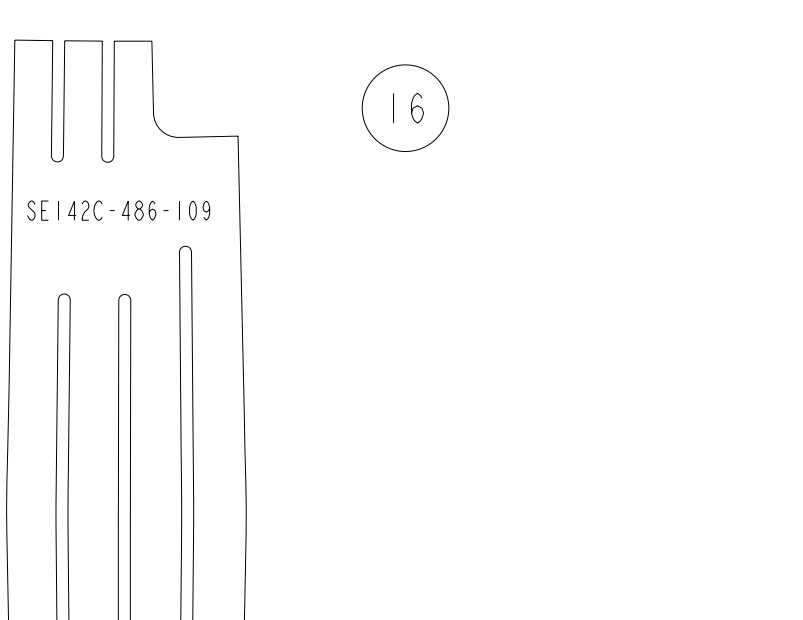

14

INSTANCE:
SE142C-486_FLAT_109

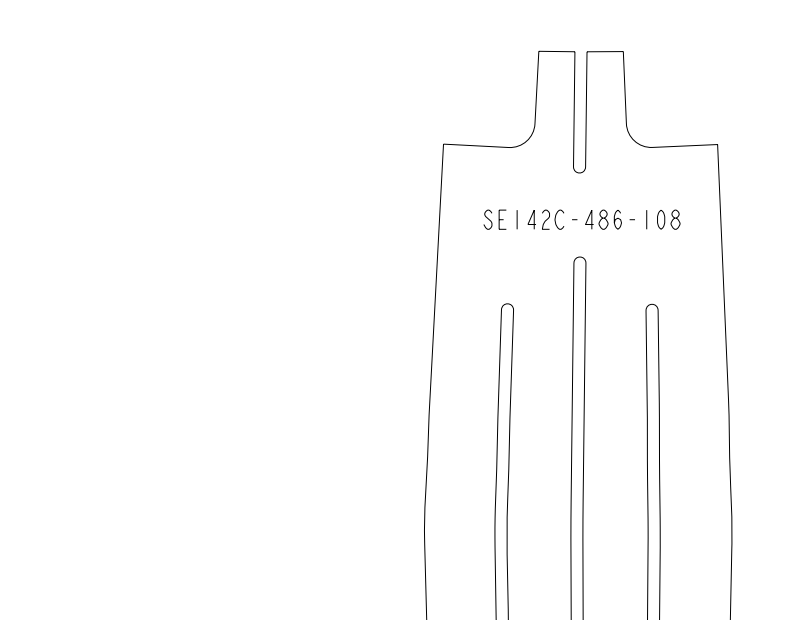

13

INSTANCE:
SE142C-486_FLAT_108-NEW

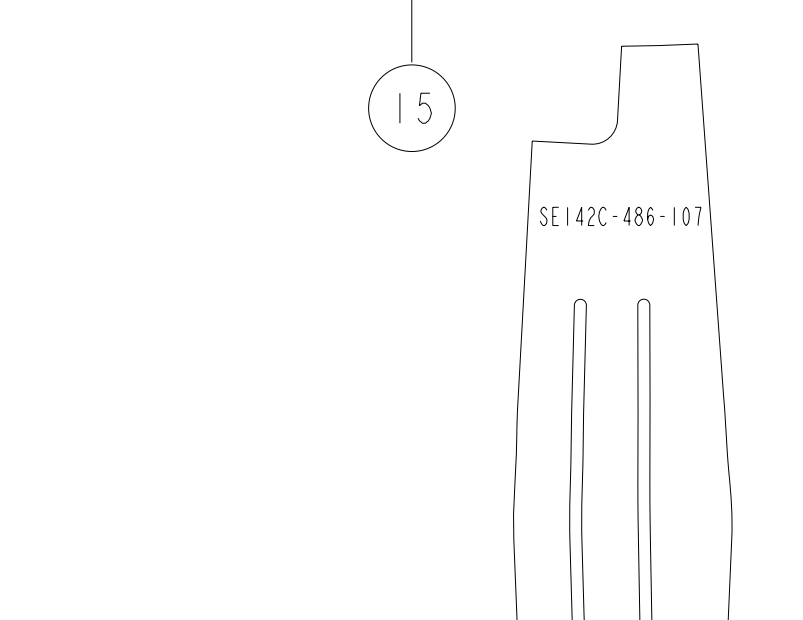

12

INSTANCE:
SE142C-486_FLAT_107-NEW

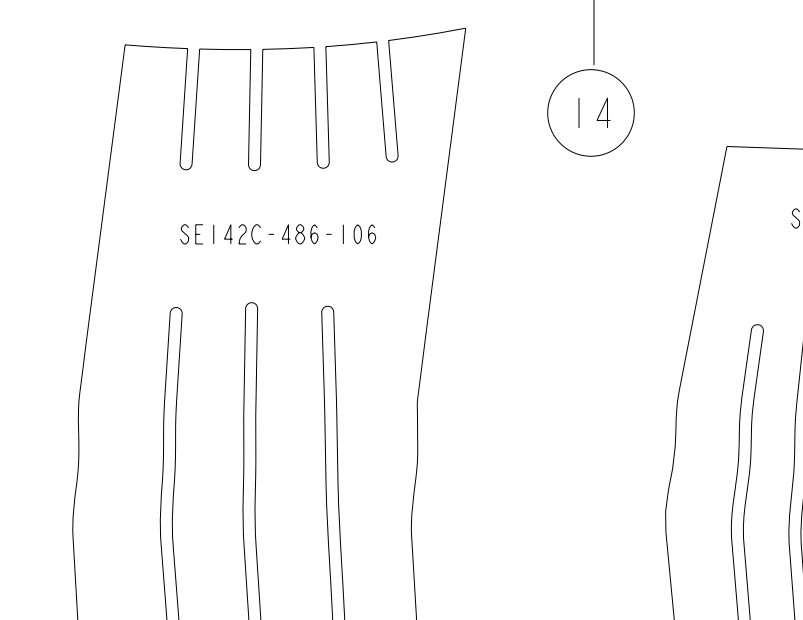

11

INSTANCE:
SE142C-486_FLAT_106-NEW

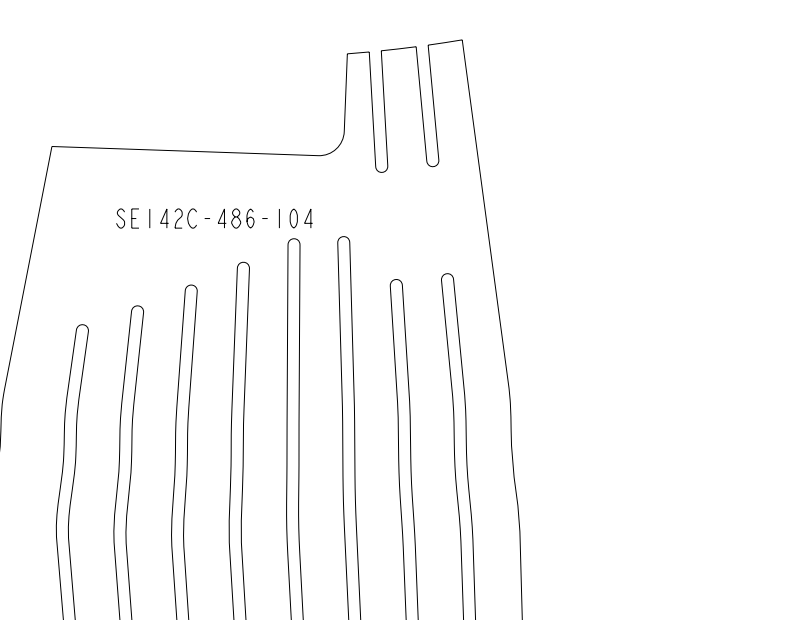

10

INSTANCE:
SE142C-486_FLAT_104-NEW

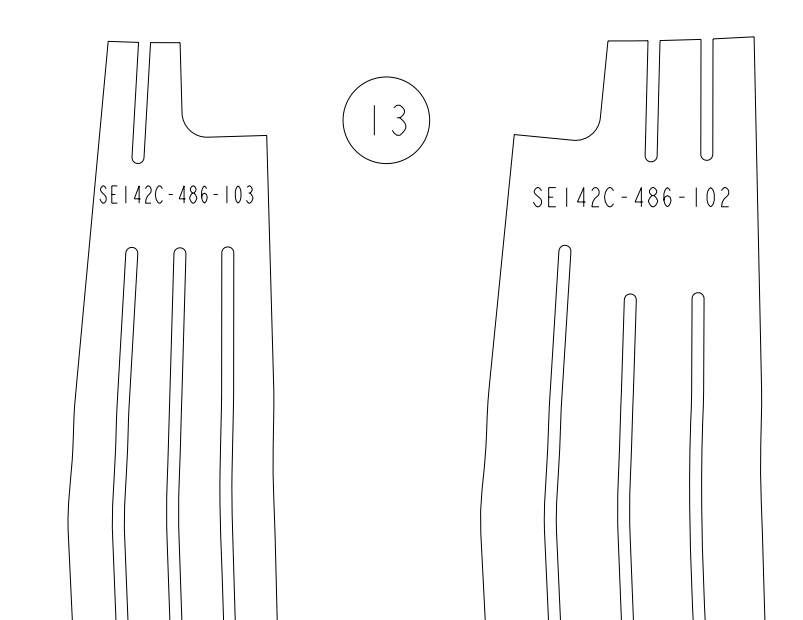

09

INSTANCE:
SE142C-486_FLAT_103-NEW

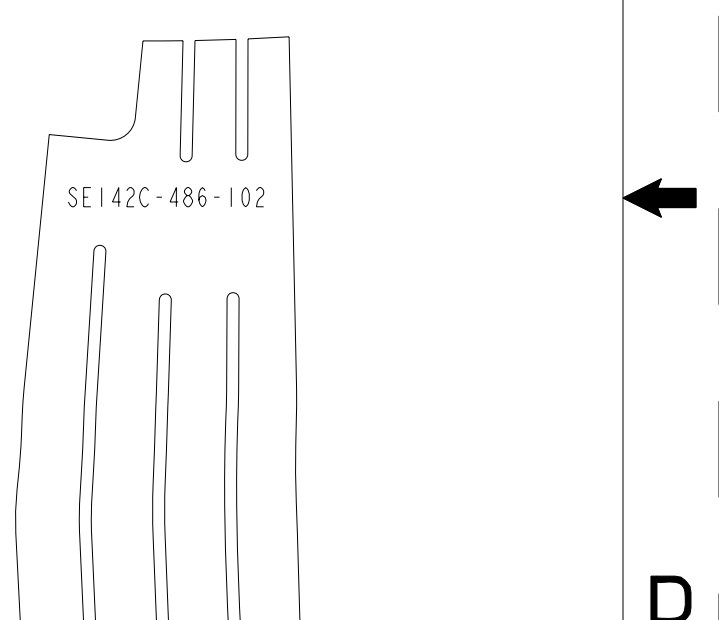

08

INSTANCE:
SE142C-486_FLAT_102

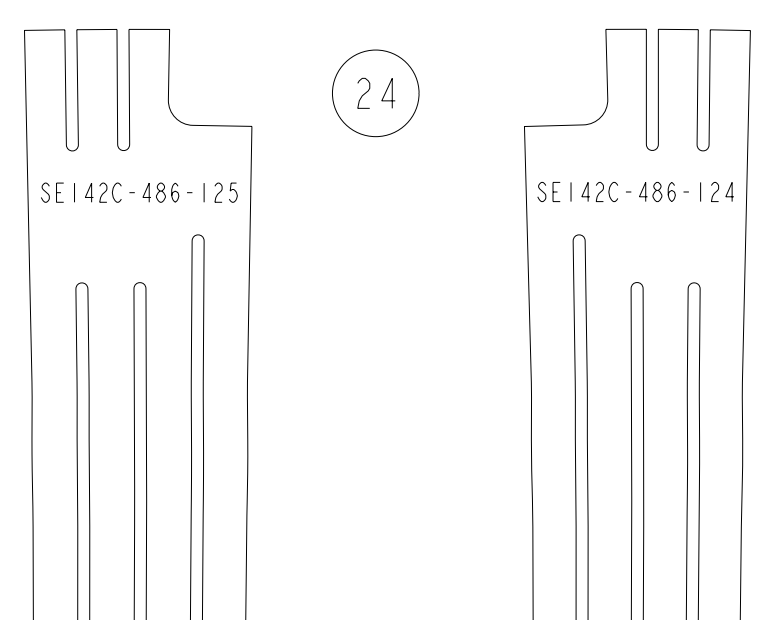

24

INSTANCE:
SE142C-486_FLAT_125

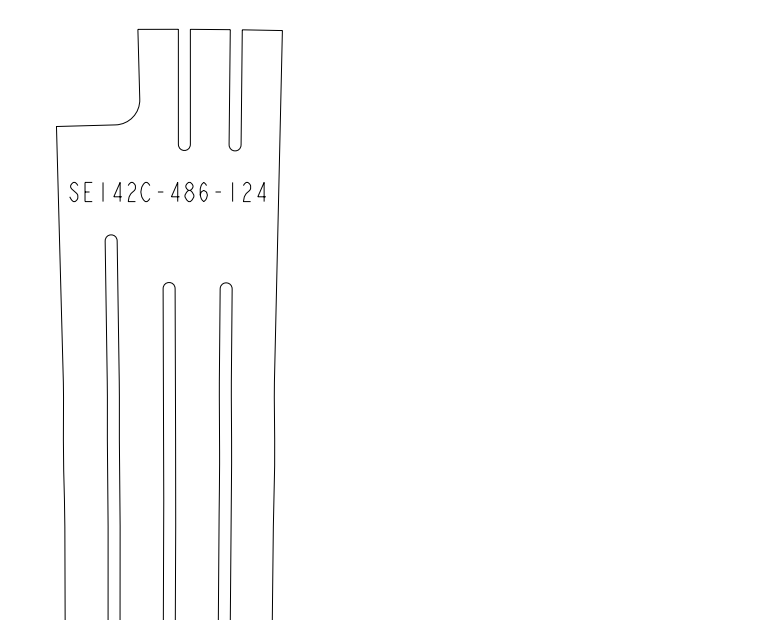

23

INSTANCE:
SE142C-486_FLAT_124

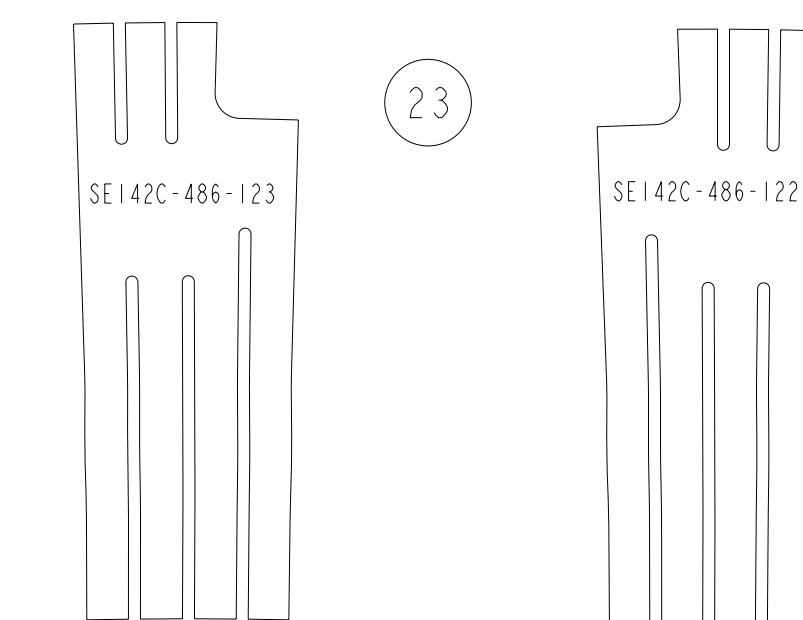

22

INSTANCE:
SE142C-486_FLAT_123

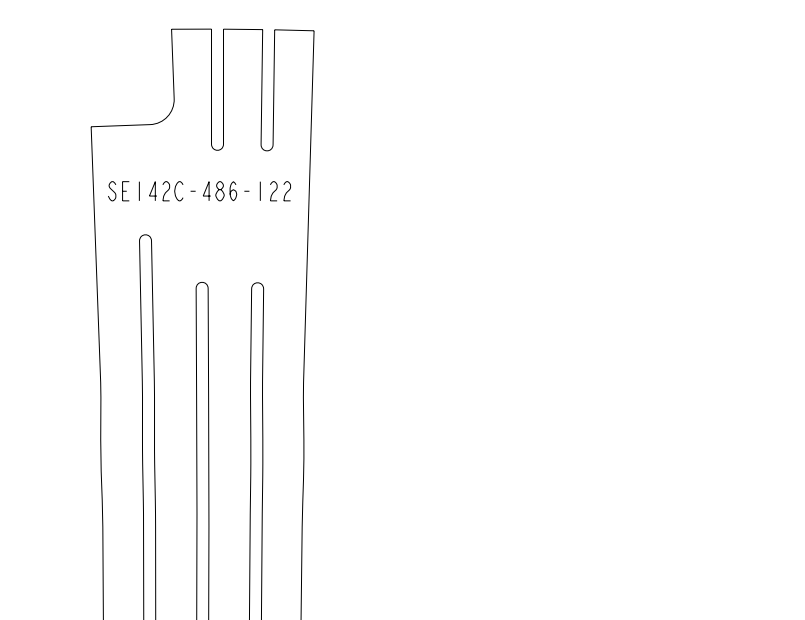

21

INSTANCE:
SE142C-486_FLAT_122

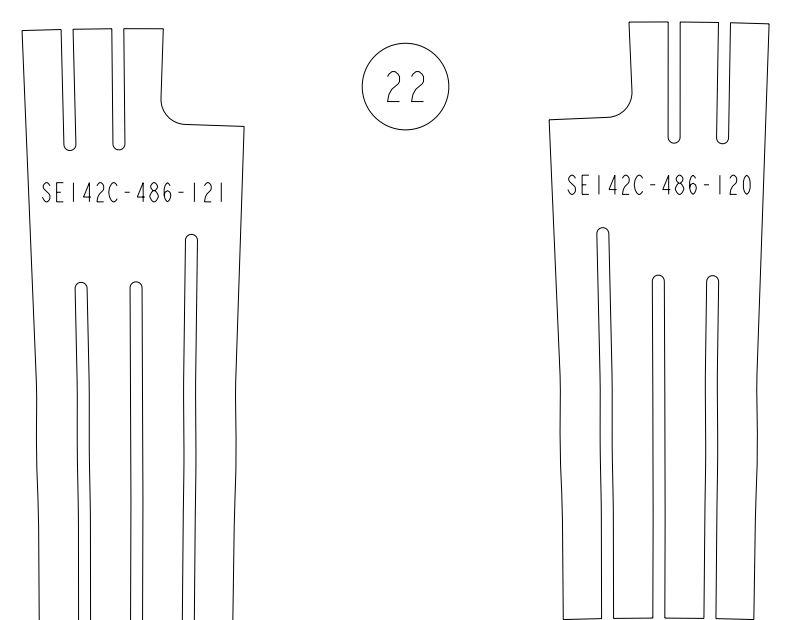

20

INSTANCE:
SE142C-486_FLAT_121

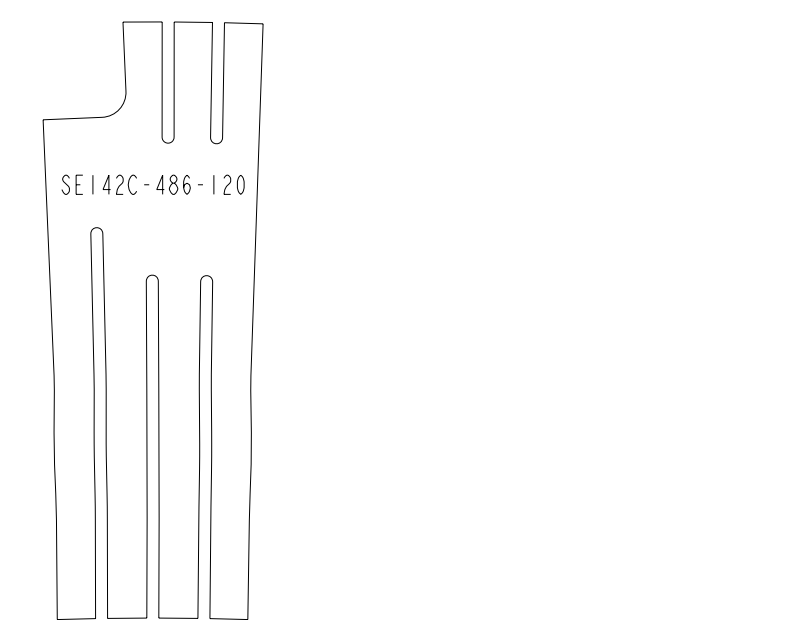

19

INSTANCE:
SE142C-486_FLAT_120

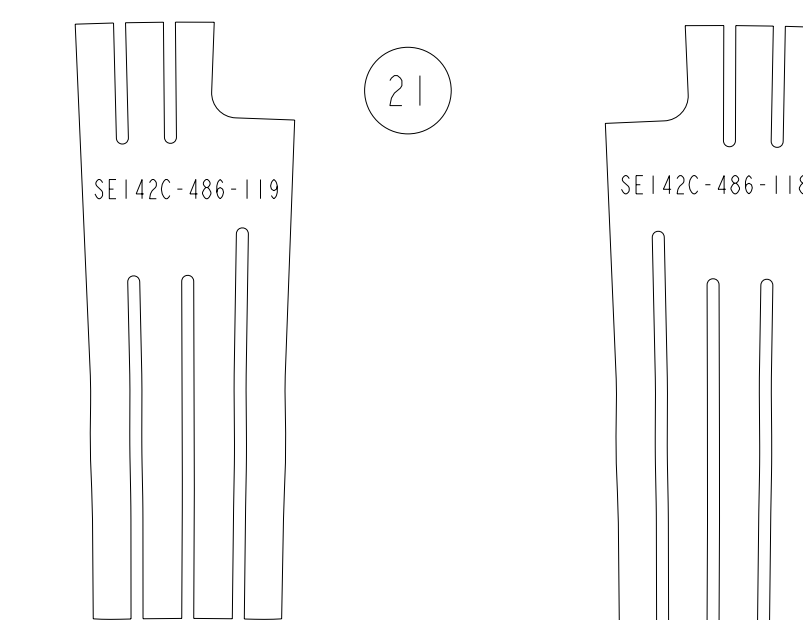

18

INSTANCE:
SE142C-486_FLAT_119

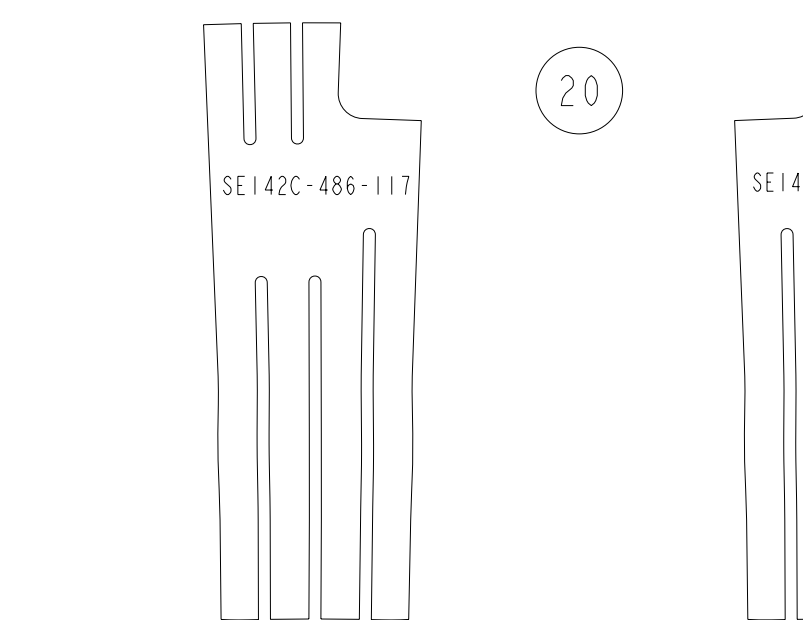

17

INSTANCE:
SE142C-486_FLAT_118

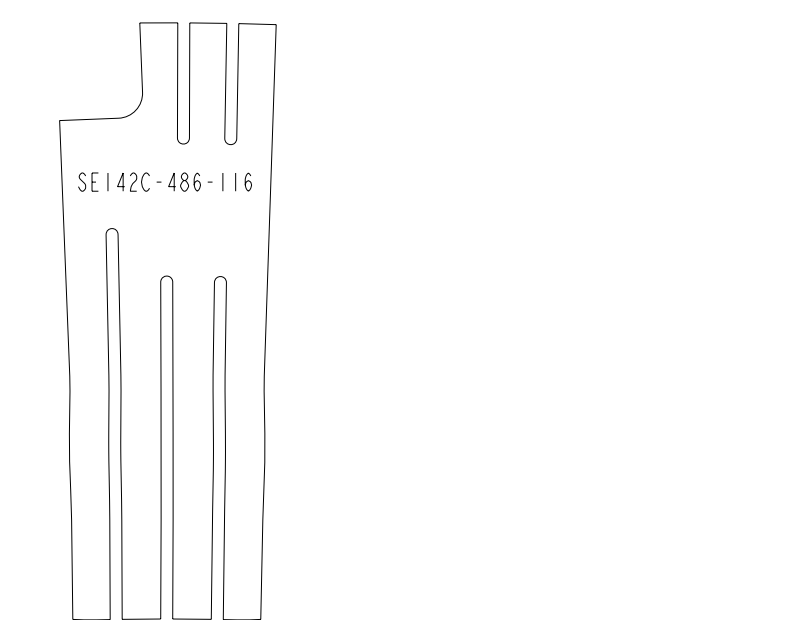

16

INSTANCE:
SE142C-486_FLAT_117

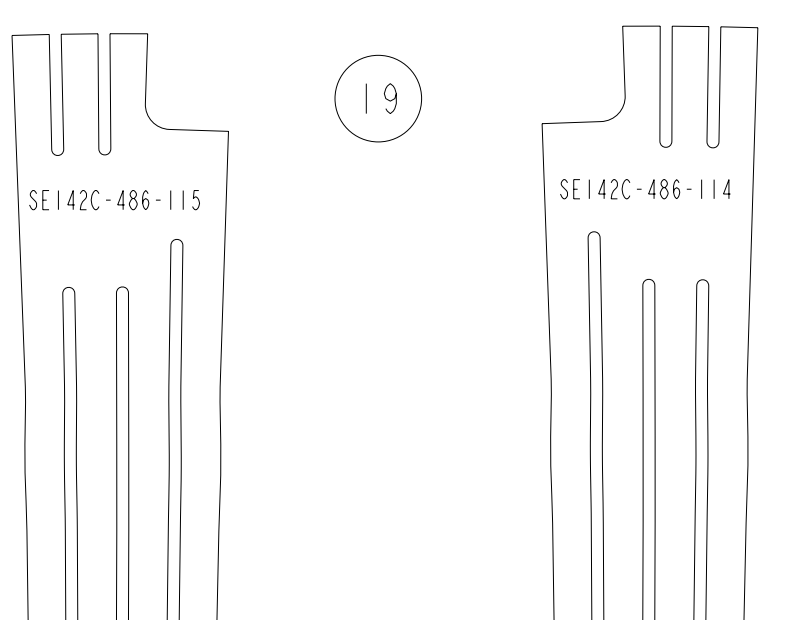

15

INSTANCE:
SE142C-486_FLAT_116

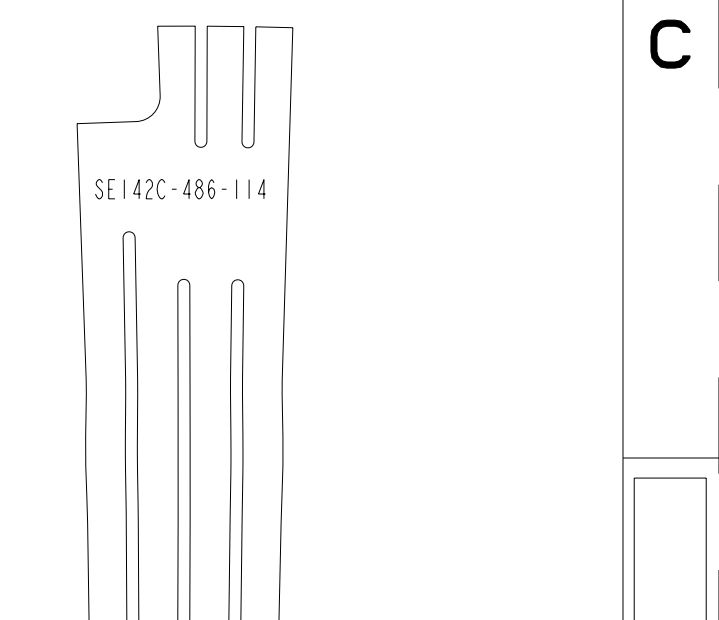

14

INSTANCE:
SE142C-486_FLAT_115

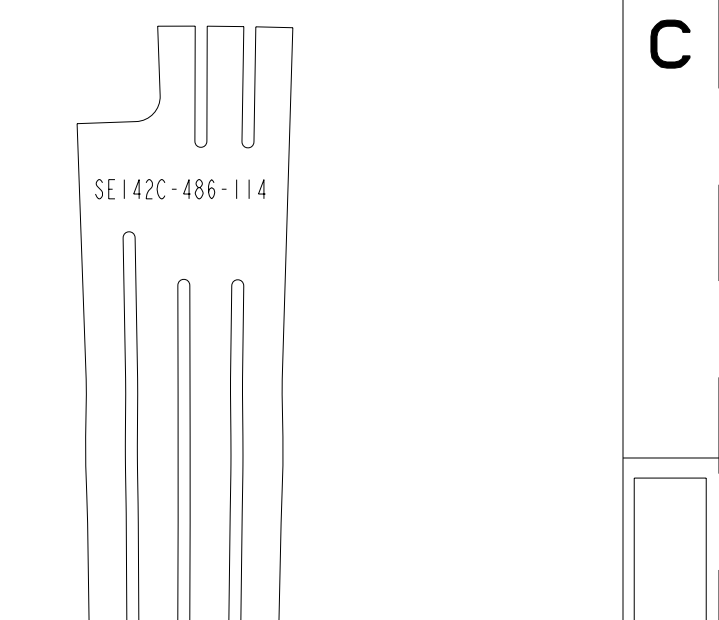

13

INSTANCE:
SE142C-486_FLAT_114

SCALE ALL VIEWS: 1.00

RELEASED FOR FABRICATION / INSTALLATION
PPPL Drafting

UT-BATTELLE		Oak Ridge National Laboratory managed for the DEPARTMENT OF ENERGY under U.S. GOVERNMENT CONTRACT DE-AC05-00OR22725 UT-BATTELLE, LLC, Oak Ridge, Tennessee	
PROJECT NAME			
NATIONAL COMPACT STELLARATOR EXPERIMENT			
MODULAR COIL TYPE - C			
SIDE -B UPPER (TOP) CHILL PLATES			
FLAT PATTERN LAYOUT			
VERSION NO.	PLANT	BLDG	FL SHT OF TYPE CLASS
4	X-10	5700	3 2 5 S U
RELEASE LEVEL		SE142C-486	
Fabrication		REV I	

8

7

6

5

4

3

2

1

SE142C-486

A



**RELEASED FOR
FABRICATION / INSTALLATION**
 PPPL Drafting

SCALE ALL VIEWS: 1.00

UT-BATTELLE		Oak Ridge National Laboratory managed for the DEPARTMENT OF ENERGY under U.S. GOVERNMENT CONTRACT DE-AC05-00OR22725 UT-BATTELLE, LLC, Oak Ridge, Tennessee PROJECT NAME			
NATIONAL COMPACT STELLARATOR EXPERIMENT					
MODULAR COIL TYPE - C SIDE -B UPPER (TOP) CHILL PLATES FLAT PATTERN LAYOUT					
VERSION NO.	PLANT	BLDG	FL	SHT OF	TYPE CLASS
4	X-10	5700	3	3 5	S U
RELEASE LEVEL		SE142C-486			
Fabrication		REV 1			

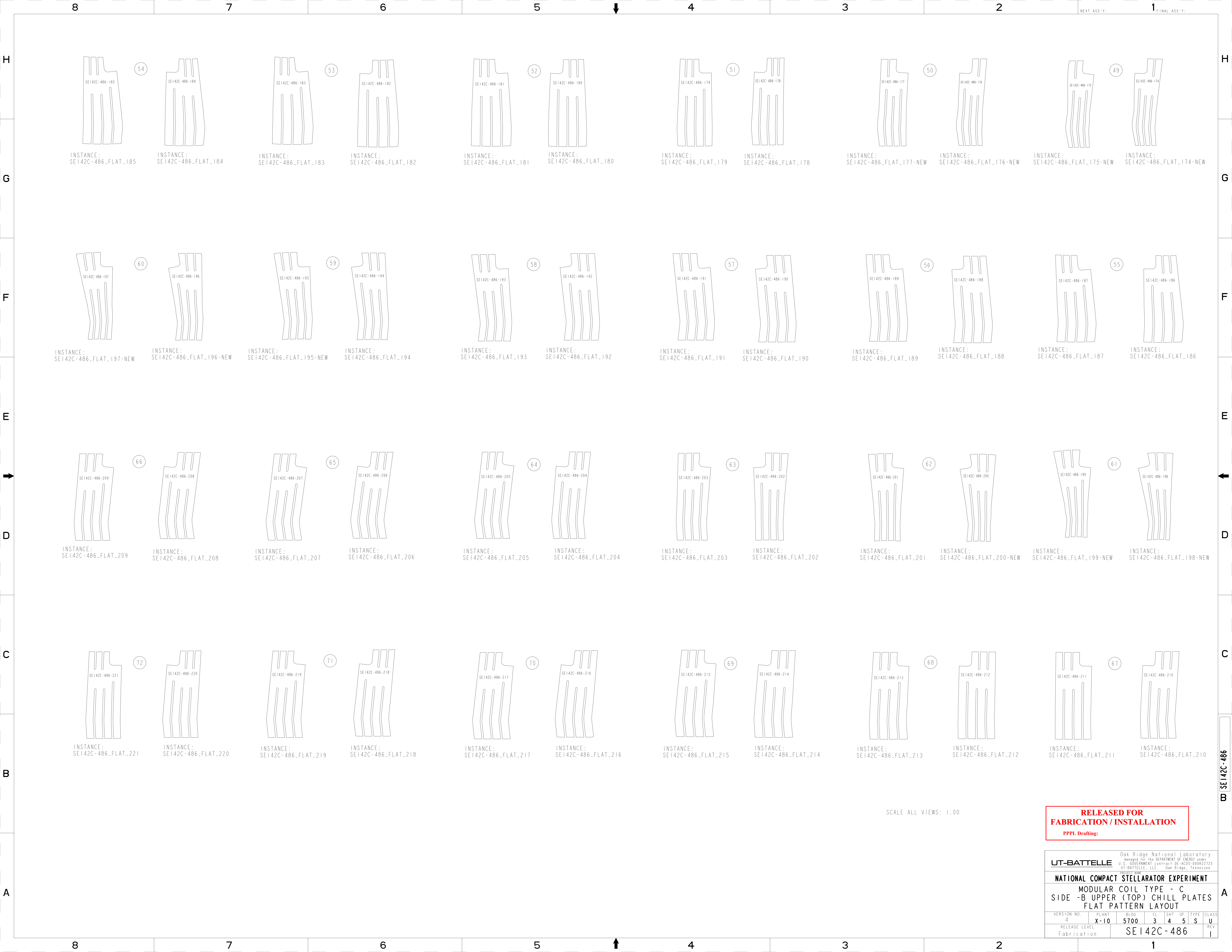

**RELEASED FOR
FABRICATION / INSTALLATION**
PPPL Drafting:

SCALE ALL VIEWS: 1.00

UT-BATTELLE		Oak Ridge National Laboratory managed for the DEPARTMENT OF ENERGY under U.S. GOVERNMENT CONTRACT DE-AC05-00OR22725 UT-BATTELLE, LLC. Oak Ridge, Tennessee			
NATIONAL COMPACT STELLARATOR EXPERIMENT					
MODULAR COIL TYPE - C					
SIDE -B UPPER (TOP) CHILL PLATES					
FLAT PATTERN LAYOUT					
VERSION NO.	PLANT	BLDG	FL	SHT OF	TYPE CLASS
4	X-10	5700	3	4 5	S U
RELEASE LEVEL		SE142C-486			
Fabrication		REV I			

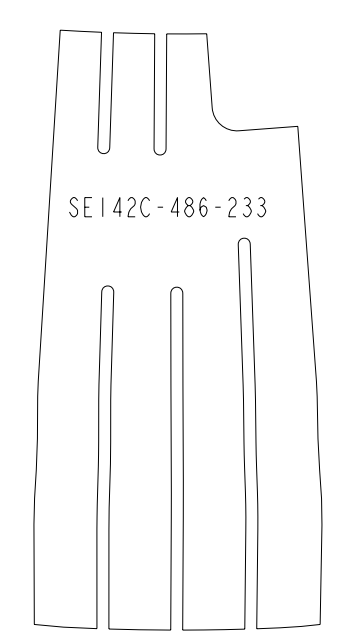

78

INSTANCE:
SE142C-486_FLAT_233

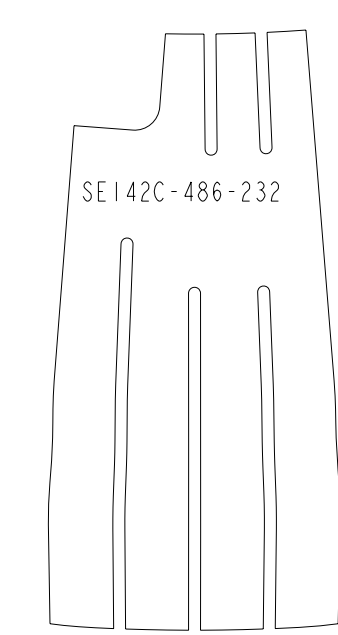

INSTANCE:
SE142C-486_FLAT_232

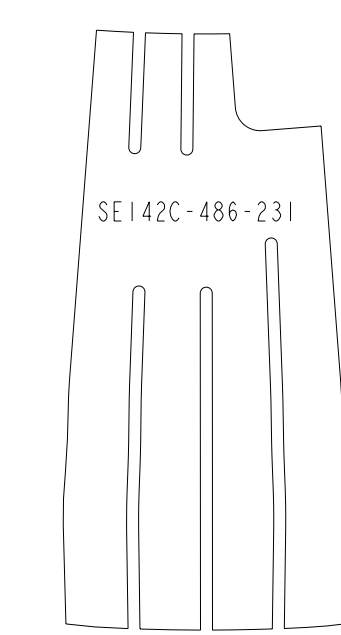

INSTANCE:
SE142C-486_FLAT_231

77

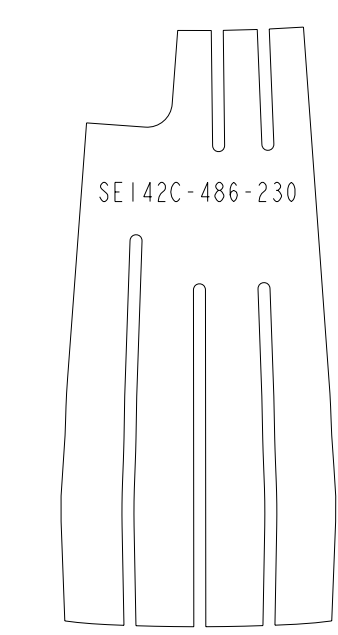

INSTANCE:
SE142C-486_FLAT_230

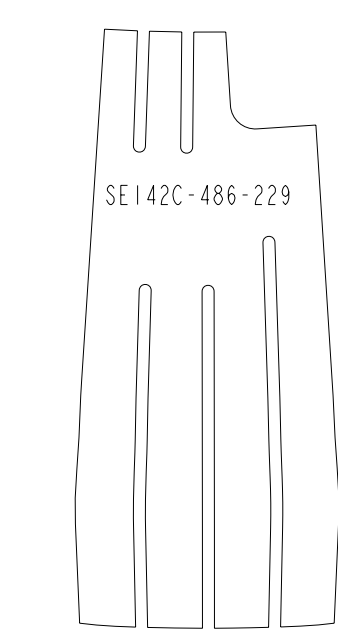

INSTANCE:
SE142C-486_FLAT_229

76

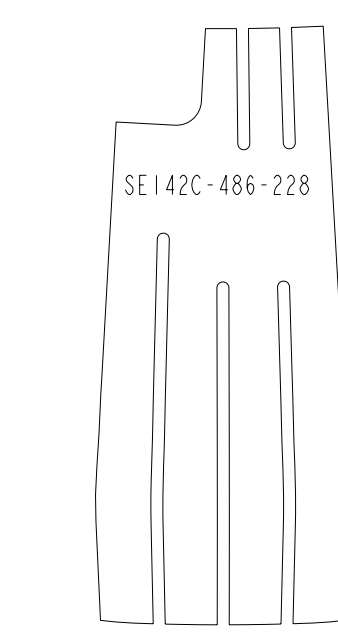

INSTANCE:
SE142C-486_FLAT_228

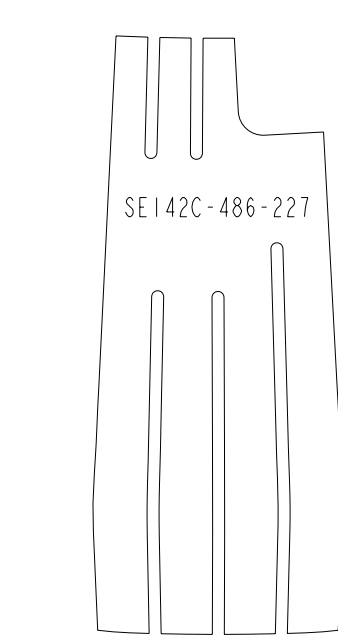

INSTANCE:
SE142C-486_FLAT_227

75

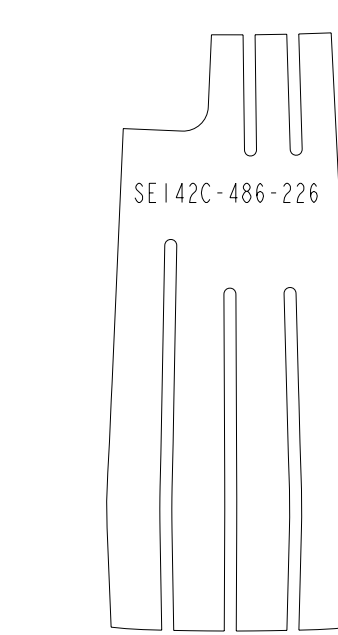

INSTANCE:
SE142C-486_FLAT_226

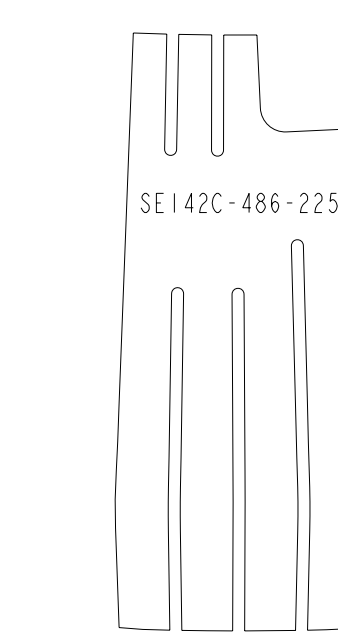

INSTANCE:
SE142C-486_FLAT_225

74

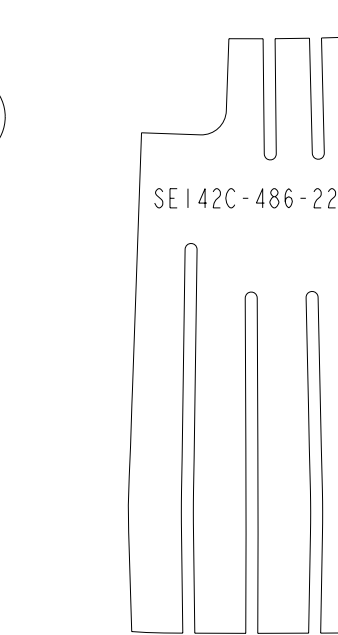

INSTANCE:
SE142C-486_FLAT_224

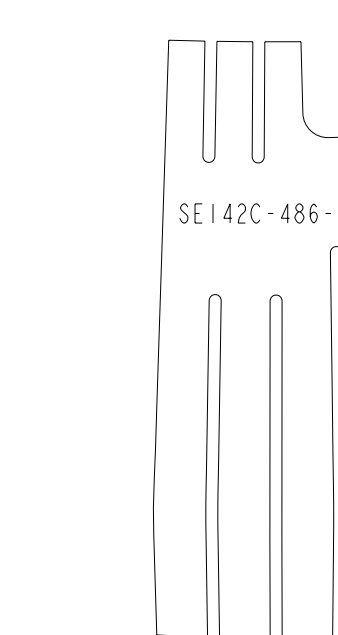

INSTANCE:
SE142C-486_FLAT_223

73

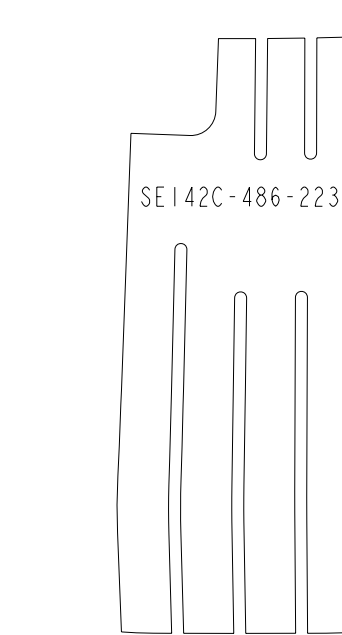

INSTANCE:
SE142C-486_FLAT_222

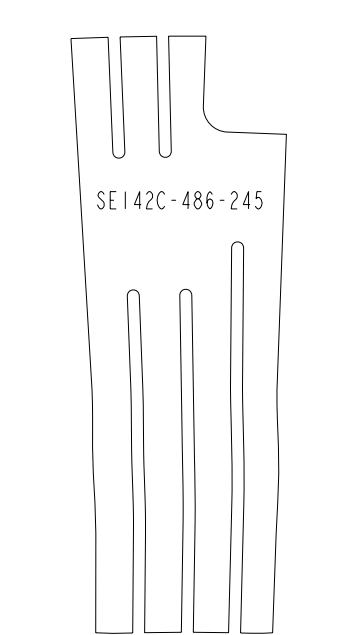

84

INSTANCE:
SE142C-486_FLAT_245

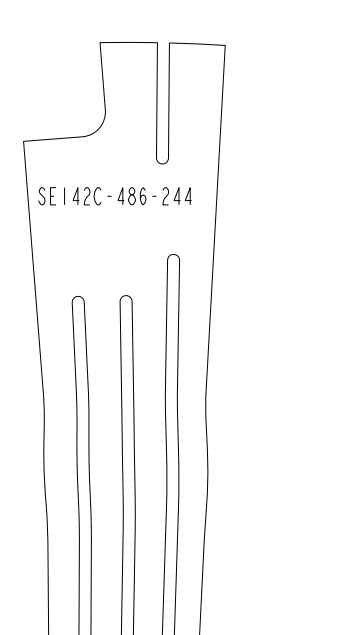

INSTANCE:
SE142C-486_FLAT_244-NEW

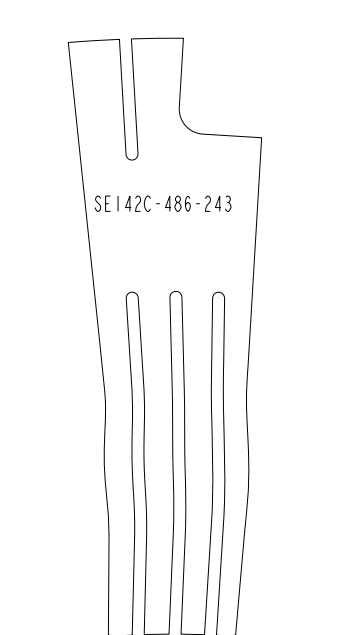

INSTANCE:
SE142C-486_FLAT_243-NEW

83

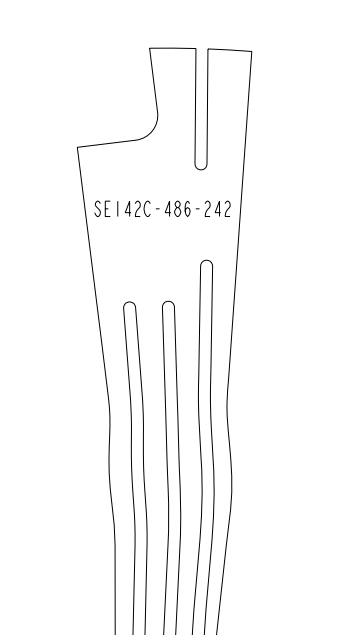

INSTANCE:
SE142C-486_FLAT_242-NEW

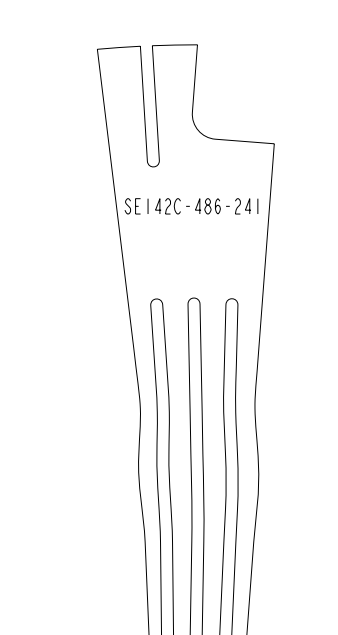

INSTANCE:
SE142C-486_FLAT_241-NEW

82

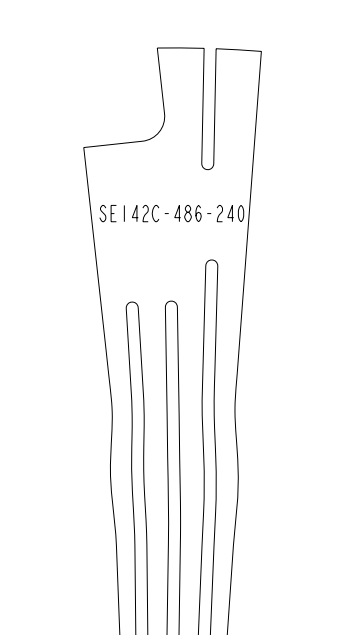

INSTANCE:
SE142C-486_FLAT_240-NEW

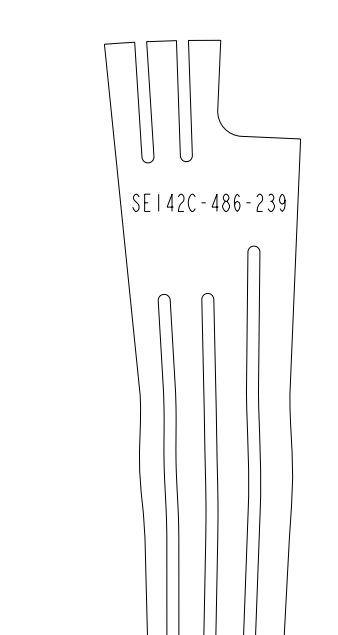

INSTANCE:
SE142C-486_FLAT_239

81

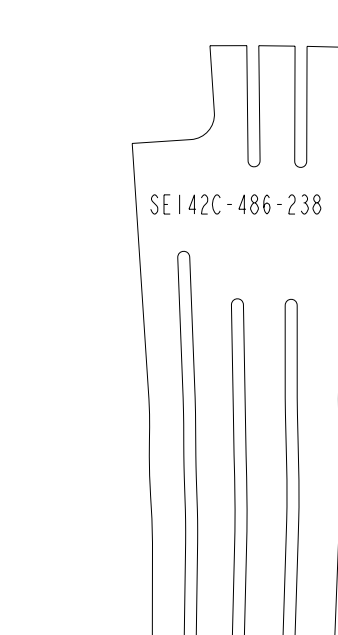

INSTANCE:
SE142C-486_FLAT_238

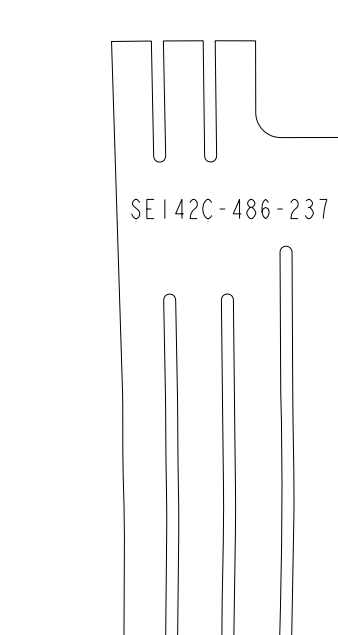

INSTANCE:
SE142C-486_FLAT_237

80

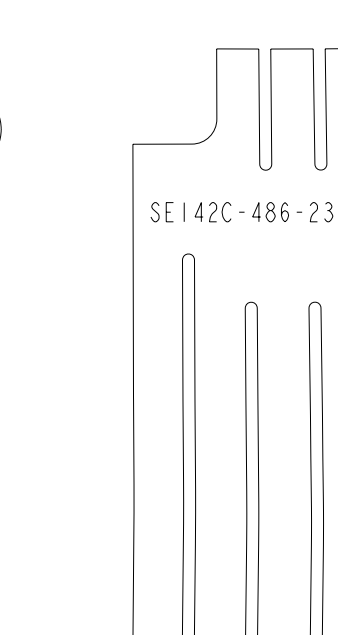

INSTANCE:
SE142C-486_FLAT_236

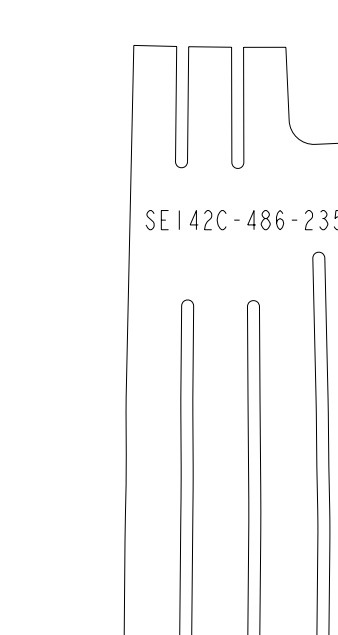

INSTANCE:
SE142C-486_FLAT_235

79

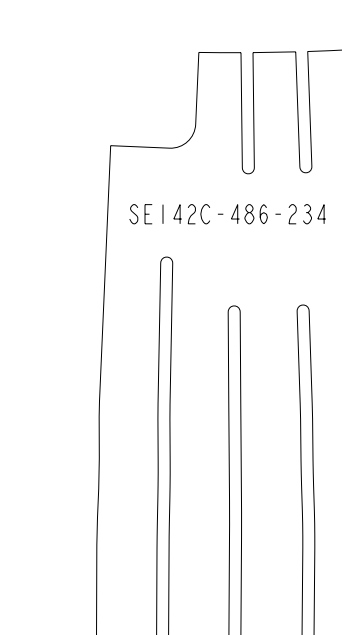

INSTANCE:
SE142C-486_FLAT_234

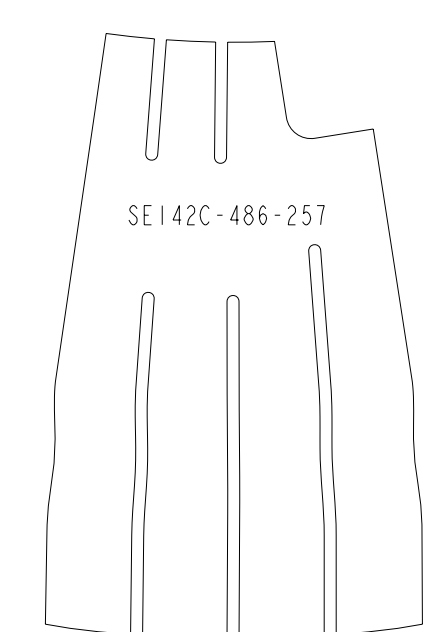

90

INSTANCE:
SE142C-486_FLAT_257

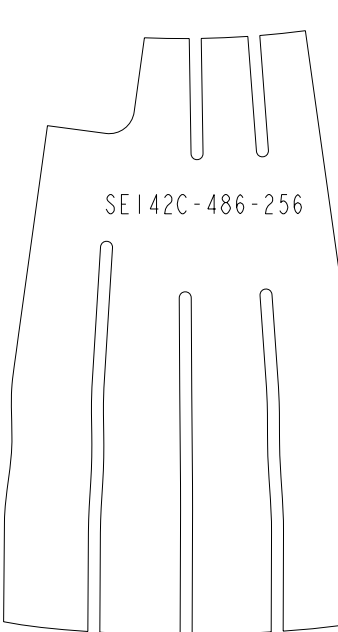

INSTANCE:
SE142C-486_FLAT_256

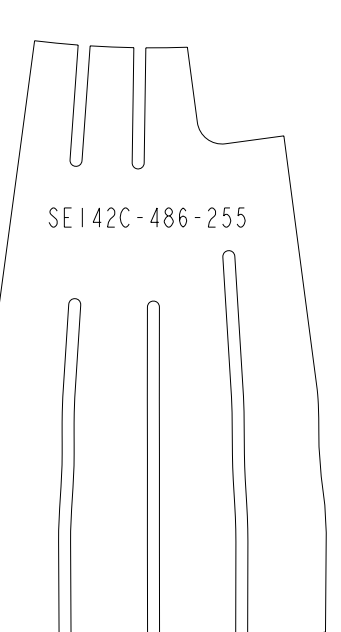

INSTANCE:
SE142C-486_FLAT_255

89

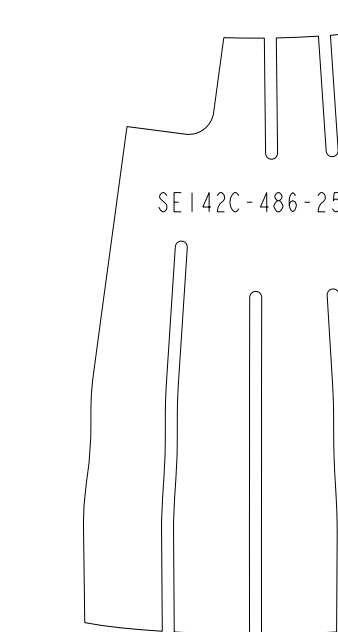

INSTANCE:
SE142C-486_FLAT_254

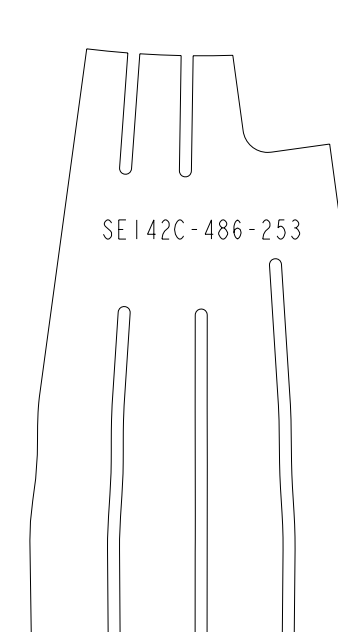

INSTANCE:
SE142C-486_FLAT_253

88

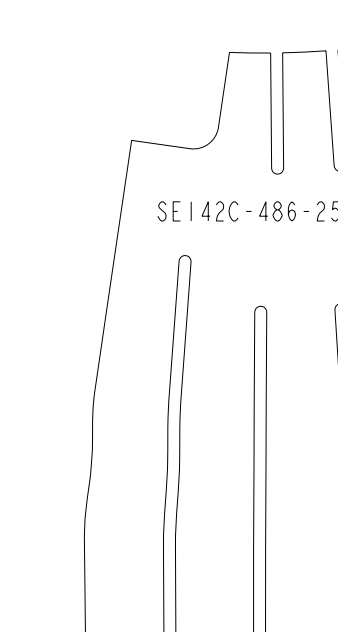

INSTANCE:
SE142C-486_FLAT_252

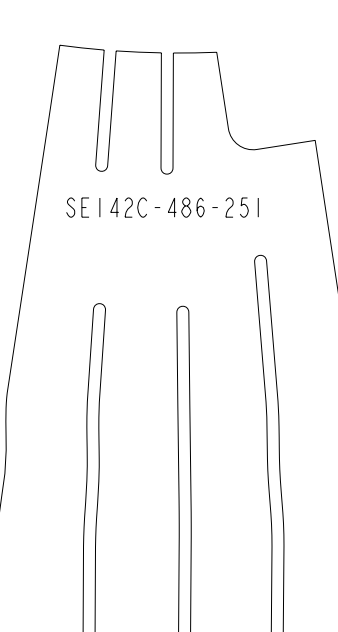

INSTANCE:
SE142C-486_FLAT_251

87

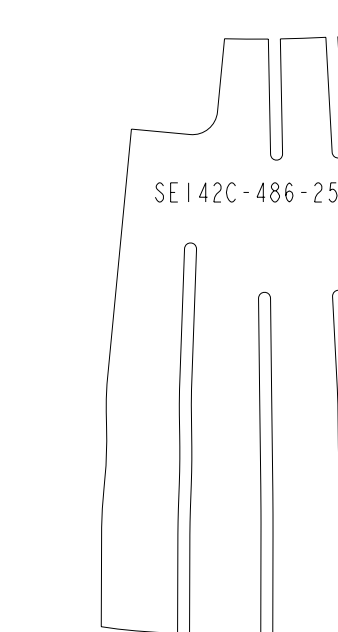

INSTANCE:
SE142C-486_FLAT_250

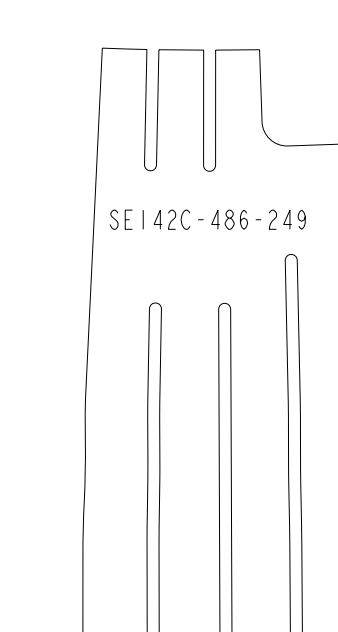

INSTANCE:
SE142C-486_FLAT_249

86



INSTANCE:
SE142C-486_FLAT_248

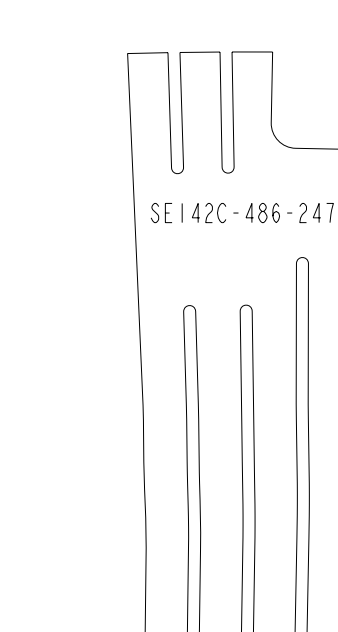

INSTANCE:
SE142C-486_FLAT_247

85

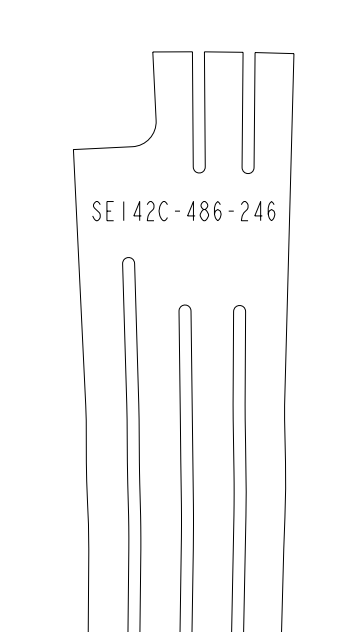

INSTANCE:
SE142C-486_FLAT_246



THESE PARTS TO BE NEMA GRADE GIICR MATERIAL

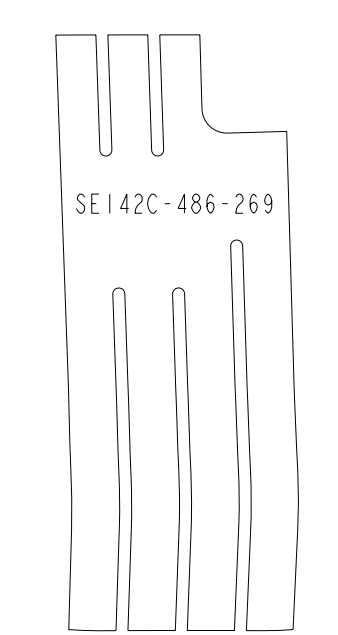

96

INSTANCE:
SE142C-486_FLAT_269

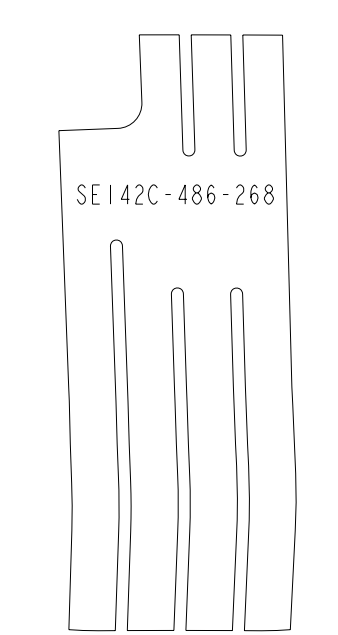

INSTANCE:
SE142C-486_FLAT_268

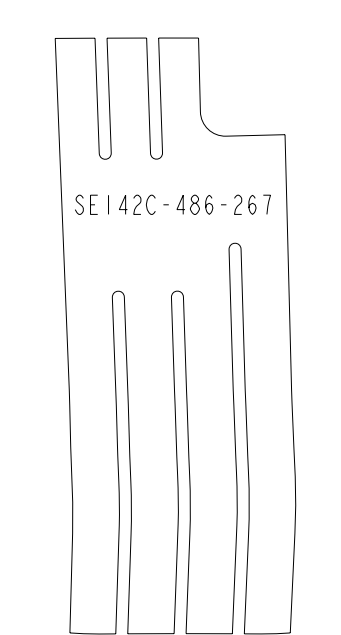

INSTANCE:
SE142C-486_FLAT_267

95

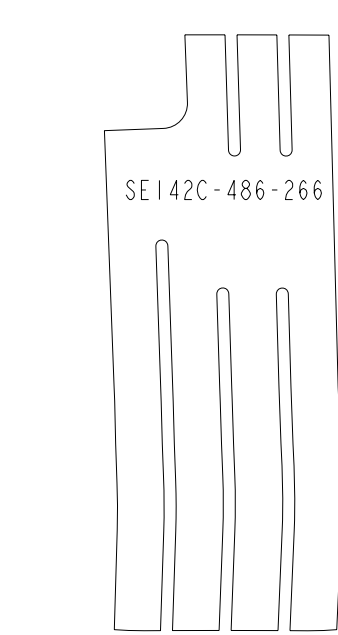

INSTANCE:
SE142C-486_FLAT_266

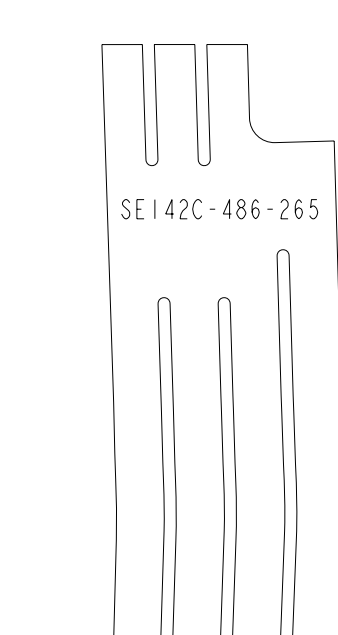

INSTANCE:
SE142C-486_FLAT_265

94

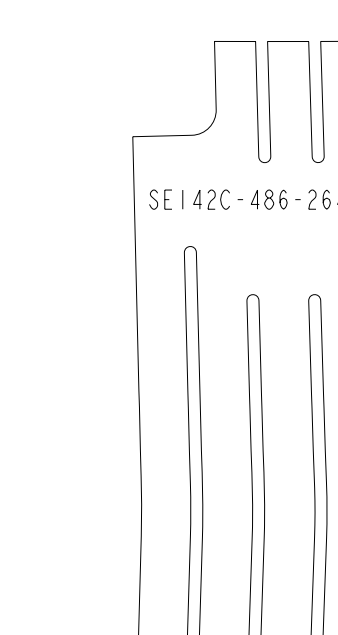

INSTANCE:
SE142C-486_FLAT_264

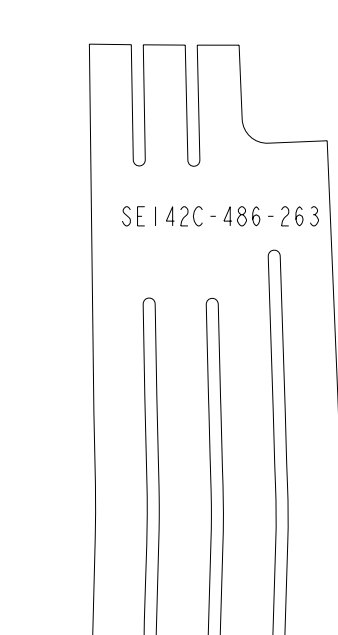

INSTANCE:
SE142C-486_FLAT_263

93

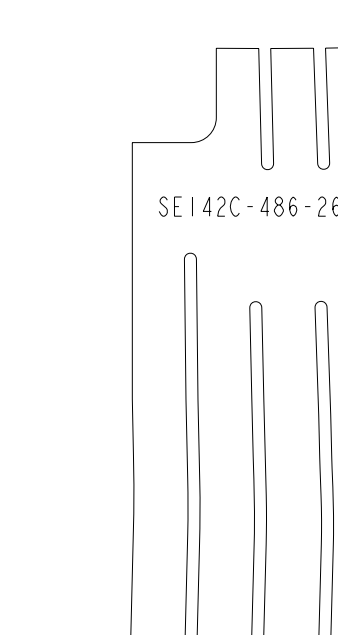

INSTANCE:
SE142C-486_FLAT_262

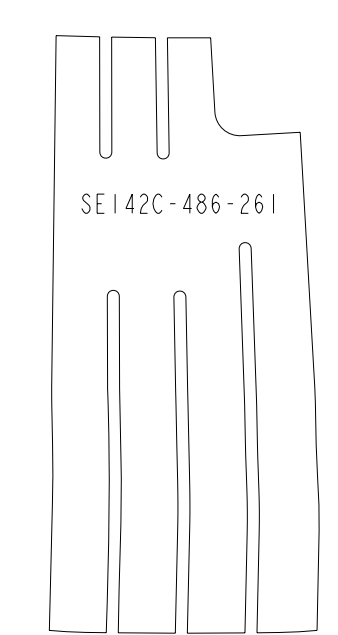

INSTANCE:
SE142C-486_FLAT_261

92

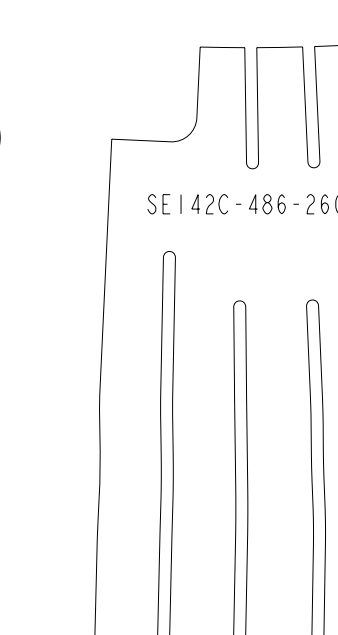

INSTANCE:
SE142C-486_FLAT_260

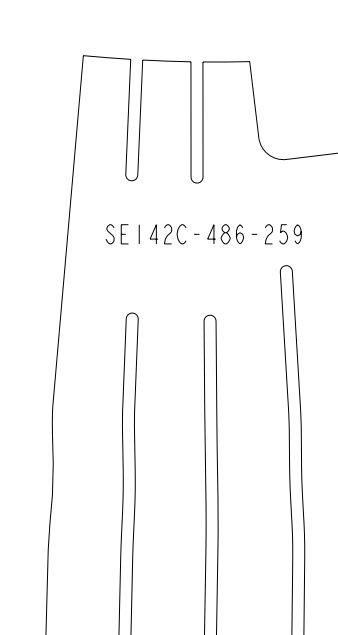

INSTANCE:
SE142C-486_FLAT_259

91

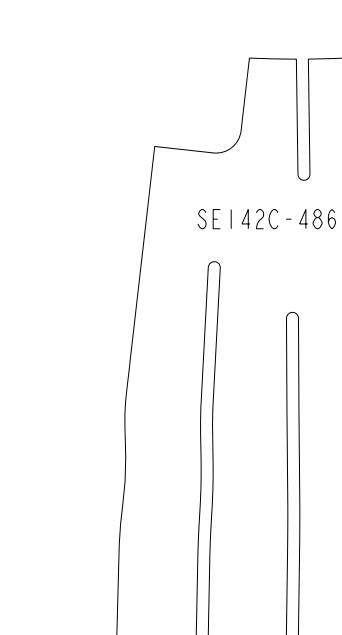

INSTANCE:
SE142C-486_FLAT_258

RELEASED FOR FABRICATION / INSTALLATION
PPPL Drafting

SCALE ALL VIEWS: 1.00

UT-BATTELLE		Oak Ridge National Laboratory managed for the DEPARTMENT OF ENERGY under U.S. GOVERNMENT CONTRACT DE-AC05-00OR22725 UT-BATTELLE, LLC. Oak Ridge, Tennessee	
PROJECT NAME NATIONAL COMPACT STELLARATOR EXPERIMENT			
MODULAR COIL TYPE - C SIDE -B UPPER (TOP) CHILL PLATES FLAT PATTERN LAYOUT			
VERSION NO. 4	PLANT X-10	BLDG 5700	FL SHT OF TYPE CLASS 3 5 5 S U
RELEASE LEVEL Fabrication		SE142C-486	