

NO.	REVISION	BY	CH	SUP	APPROVED	DATE
1	REVISED PER ECN-5371	LM	TB	JS	T. BROWN	6-18-08

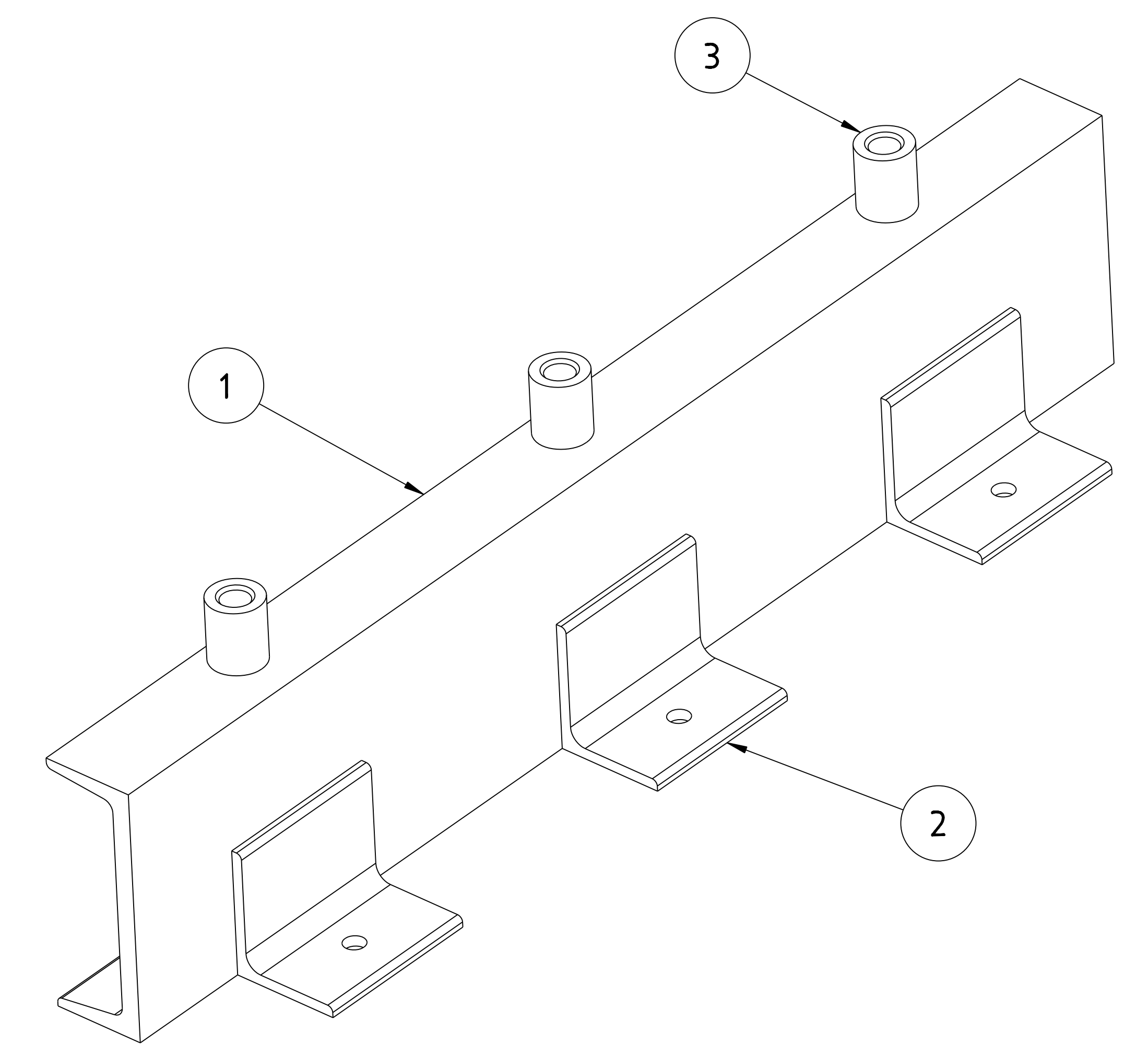
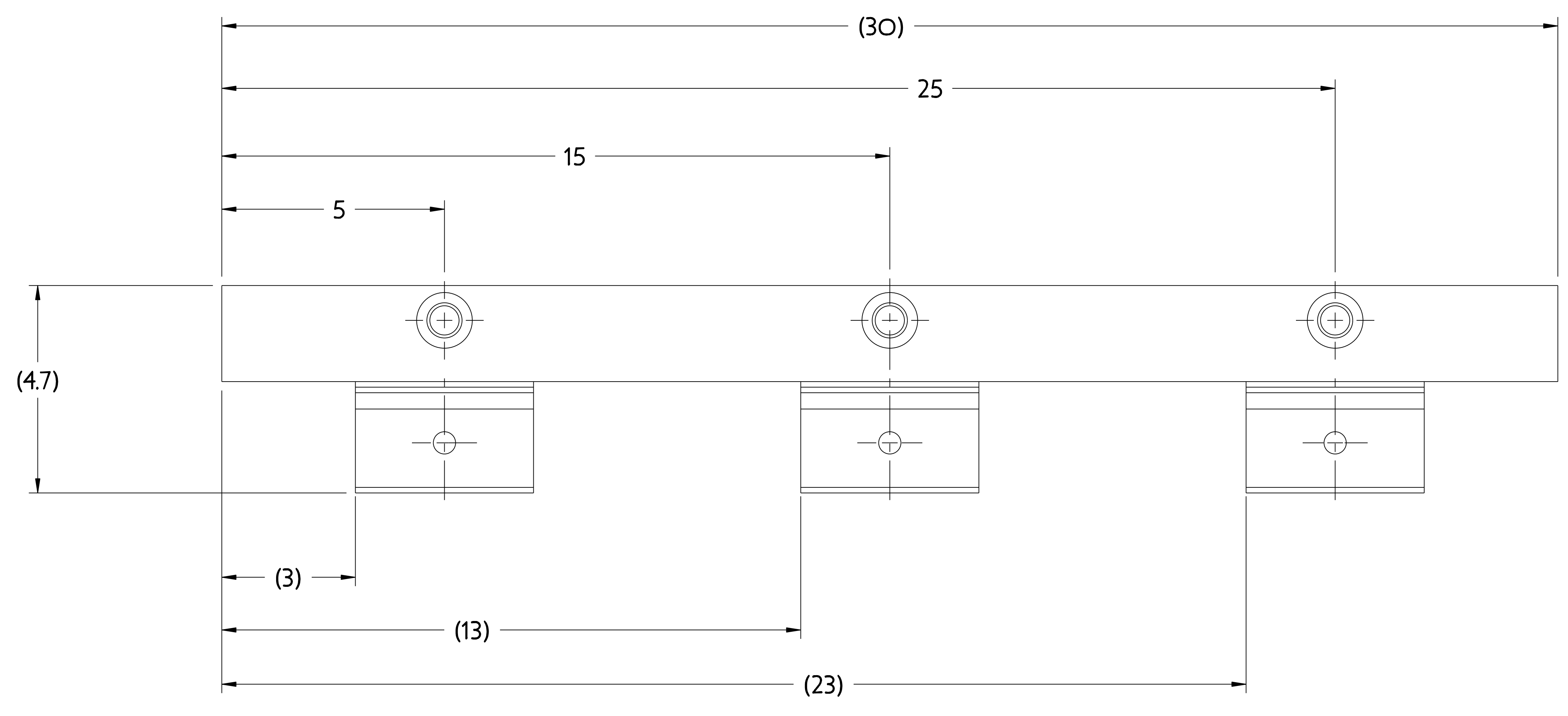

NOTE

WELDING SHALL BE PERFORMED IN ACCORDANCE WITH THE REQUIREMENTS OF AWS D1.1 SECTION 6 OR PPPL PROCEDURE NO. ENG-37.

VISUAL WELD INSPECTION SHALL BE PERFORMED IN ACCORDANCE WITH THE ACCEPTANCE CRITERIA OF AWS D1.1.

NOTE ORIENTATION OF ALL PARTS PRIOR TO WELDING.

SAND BLAST AND APPLY 2 COATS "SAFETY YELLOW" PAINT.

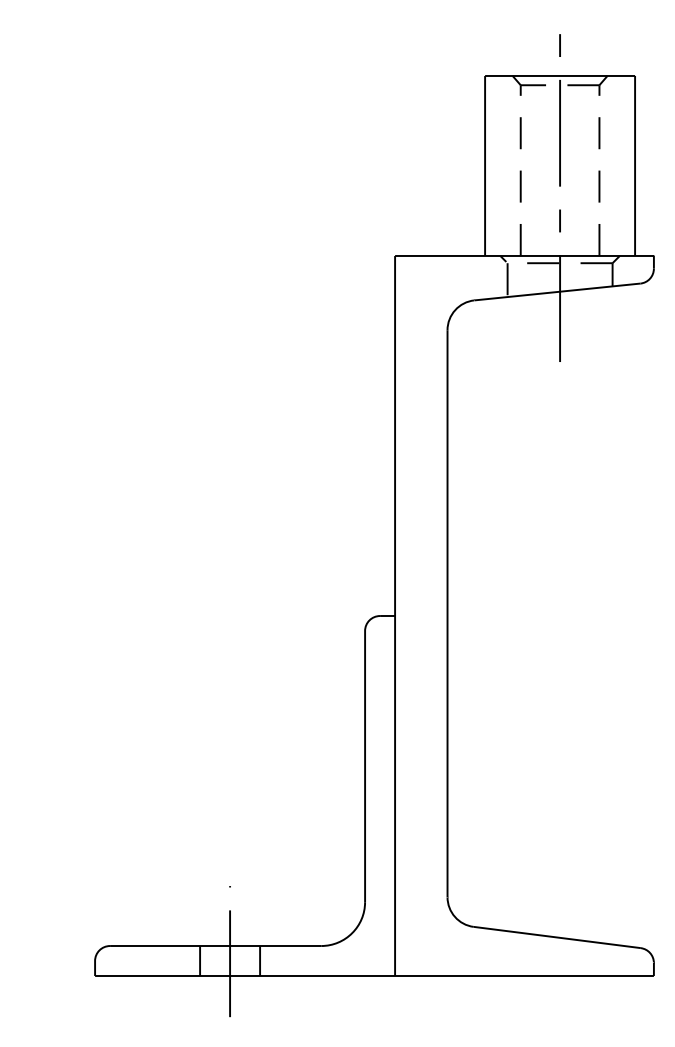
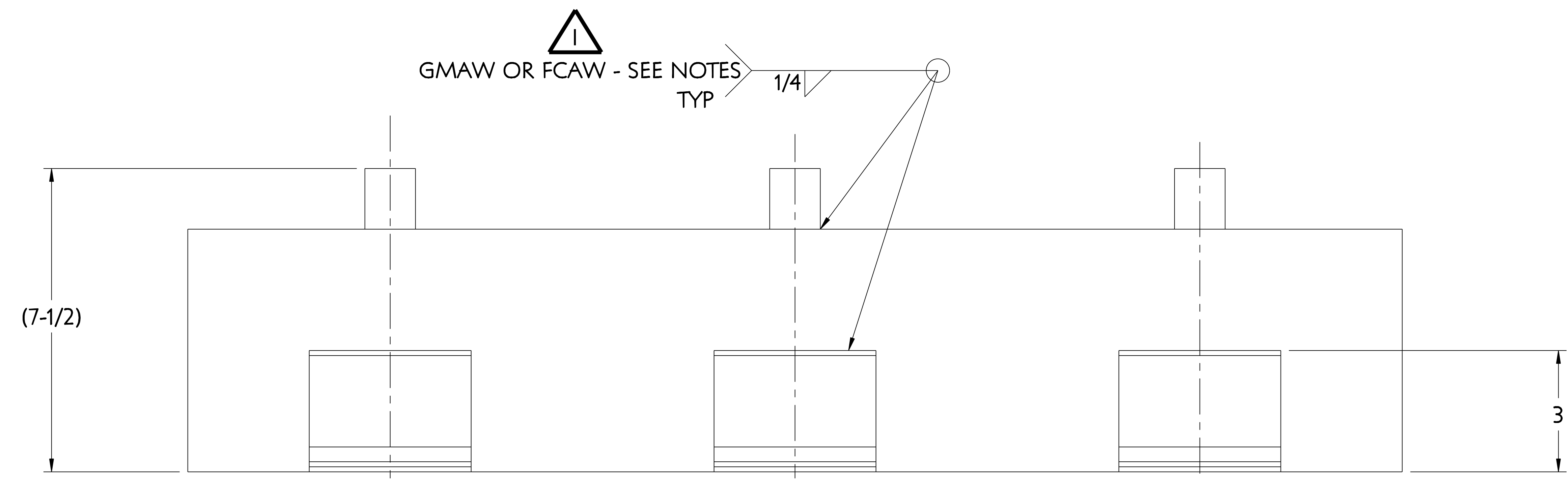

(2) ASSEMBLIES REQ'D

RELEASED FOR
FABRICATION / INSTALLATION
PPPL Drafting

PART NO.	DRAWING NO	NOMENCLATURE OR DESCRIPTION	MATERIAL	QTY REQD
3	SE186-331-4	CLAMPING THREADED BOSS	CARBON STEEL	3
2	SE186-331-3	FLOOR BOLTING CLIP	CARBON STEEL	3
1	SE186-331-2	ANTI-TIP CHANNEL	CARBON STEEL	1

PARTS LIST

COMPUTER GENERATED DRAWING MANUAL CHANGES NOT PERMITTED	CENTRAL FILES: UNLESS OTHERWISE SPECIFIED	PRINCETON PLASMA PHYSICS LABORATORY PRINCETON UNIVERSITY	
Pro E	DIMENSIONS ARE IN INCHES MACHINE SURFACES UNLESS OTHERWISE SPECIFIED	NATIONAL COMPACT STELLARATOR EXPERIMENT	
DO NOT VERIFY INFORMATION BY SCALING DRAWING	BREAK SHARP EDGES .005/.020	STELLARATOR CORE TOOLING DESIGN & FABRICATION ANTI-TIP CHANNEL WELDMENT	
WEIGHT 38.0 lbs	SCALE 0.625	TOLERANCES NON-CUMULATIVE	DSN: J. RUSHINSKI 8-2-2007 DRAWING NO:
MODEL NAME SE186-332	NEXT ASSEMBLY	DECIMAL-INCH FRACTIONS	CHK: M. COLE 8-2-2007
WELDING ENGINEER G. GETTELFINGER 8-2-2007		.XX +/- .000 0°-12° +/- .010	ENGR: T. BROWN 8-2-2007
		.XXX +/- .005 12°-120° +/- .124	SUPV: J. SIEGEL 8-2-2007
		ANGULAR +/- .0°-15° OVER 120° +/- .124	

SE186-332

SHEET 1 OF 1 REV 1

RELEASE LEVEL: Fabrication
DWG VERSION NO: 6

NCSX-SE186-332