

NCSX Field Period Assembly Review and Comments

In the process of completing the conceptual design of the modular coil (MC) turning fixture I looked at the overall baseline Field Period Assembly scheme that was laid out for the PDR to see how the MC turning fixture design would impact it. I also took a shot at laying out assembly tasks which I felt could be applied to a timeline (see table 1). I'm sure that there will be comments and additions/subtractions and changes made; my intent was to identify, what I thought, where the critical assembly steps. I have some comments on the timeline later in this report.

With the Field Period assembly on the critical path schedule a few steps can be taken to improve the timeline of the assembly process. This includes: 1) performing metrology trials long before parts arrive to validate that assembly methods can meet tolerance requirements; 2) fabricate, operate and qualify the accuracy of the modular coil turning fixture leaving sufficient time in the schedule to make adjustments if needed; and 3) preassembling the TF and field error correction coils (shown in Figure 1) to validate fit up and make adjustments in alignment as necessary.

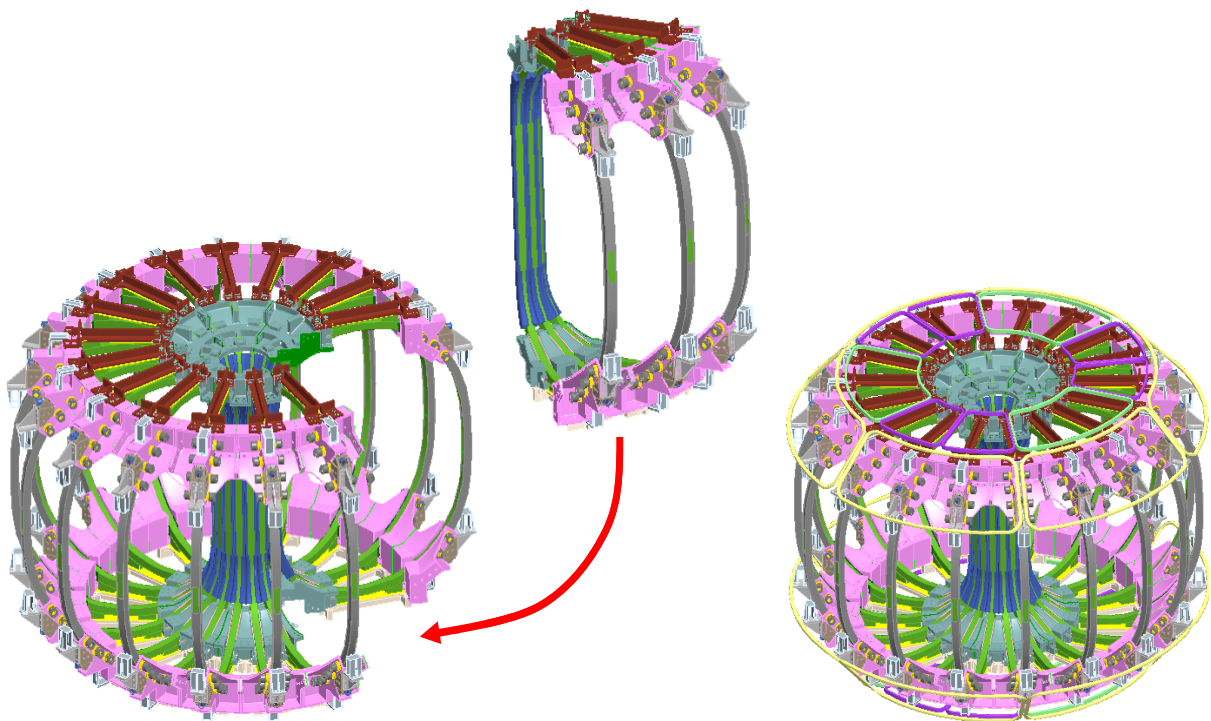

Fig. 1a) Full TF Coil Assembly

Fig 1b) TF Assembly with FECC's

Figure 1. Preassembly of TF and Field Error Correction Coils

The module coil turning fixture assembly (shown in Figure 2) consists of the turning fixture, the base guide rail, the vacuum vessel support stand, and a gantry crane used to off load the right hand module coil once it has been positioned. The design philosophy used in laying out the modular coil turning fixture was to provide six degrees of freedom in motion and adjustment accuracy to properly position a half period modular coil assembly within its designated positional tolerance. The mechanisms defined in the turning fixture design have the capability to meet the assembly tolerances. This also implies that the load transfer from the turning fixture to the gantry crane can be done without degrading this positional tolerance. If this assumption can not be met then additional positional adjustments are needed when supported off the gantry crane, requiring mechanisms / support schemes not yet defined and additional steps added to the timeline schedule. I'm hoping that this will not be necessary. Again, we

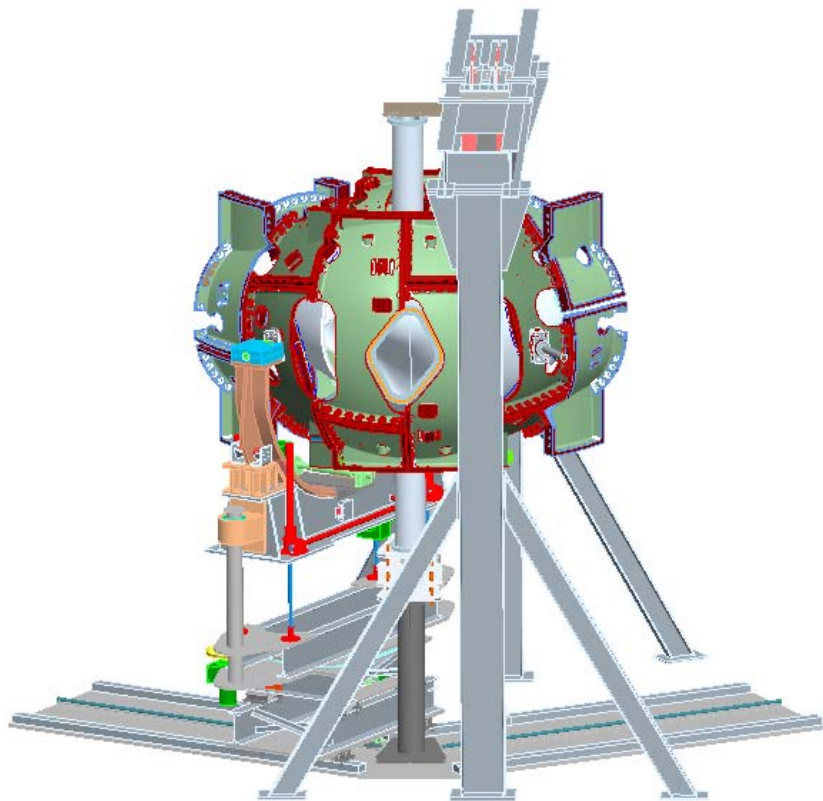

Figure 2 Module Coil Turning Fixture Assembly

need to fabricate the turning fixture assembly and develop performance tests to validate its operational accuracy and make corrective measures if necessary long before components are need to be assembled.

The test cell crane will be used initially to retrieve the half period module coil and support it while it is loaded on the turning fixture. It will also be used to remove the fully assembled module coil assembly. I feel there needs to be a separate assembly station to complete the final stage of the field period assembly (adding the vacuum vessel ports, TF and field error correction coils) for two main reasons. First, the module coil turning fixture assembly will require a higher precision in its construction and to duplicate this at three assembly stations would be cost prohibitive. Second, the rotation of the three coil TF assembly in place will require support adjustments which would require removing the gantry crane and turning fixture; this would take time and require repositioning of the gantry crane and turning fixture and alignment checks. I've concluded that the full period assembly should involve a four stage process. Stage 1 would involve the vacuum vessel preparation (one station required). Stage 2 develops the left and right assembly of the half period module coils (one station required). Stage 3 uses the turning fixture to rotate the module coils over vacuum vessel (one station required). Stage 4 completes the full period assembly involving installing ports, TF and trims coils (possibly three stations required).

I've pictorially illustrated the assembly operations in figure 3 with a corresponding spread sheet listing in Table 1, at the end of this report, showing the timeline "estimate" for the major operations listed. The total time is in line with the original PDR estimate of 179 days.

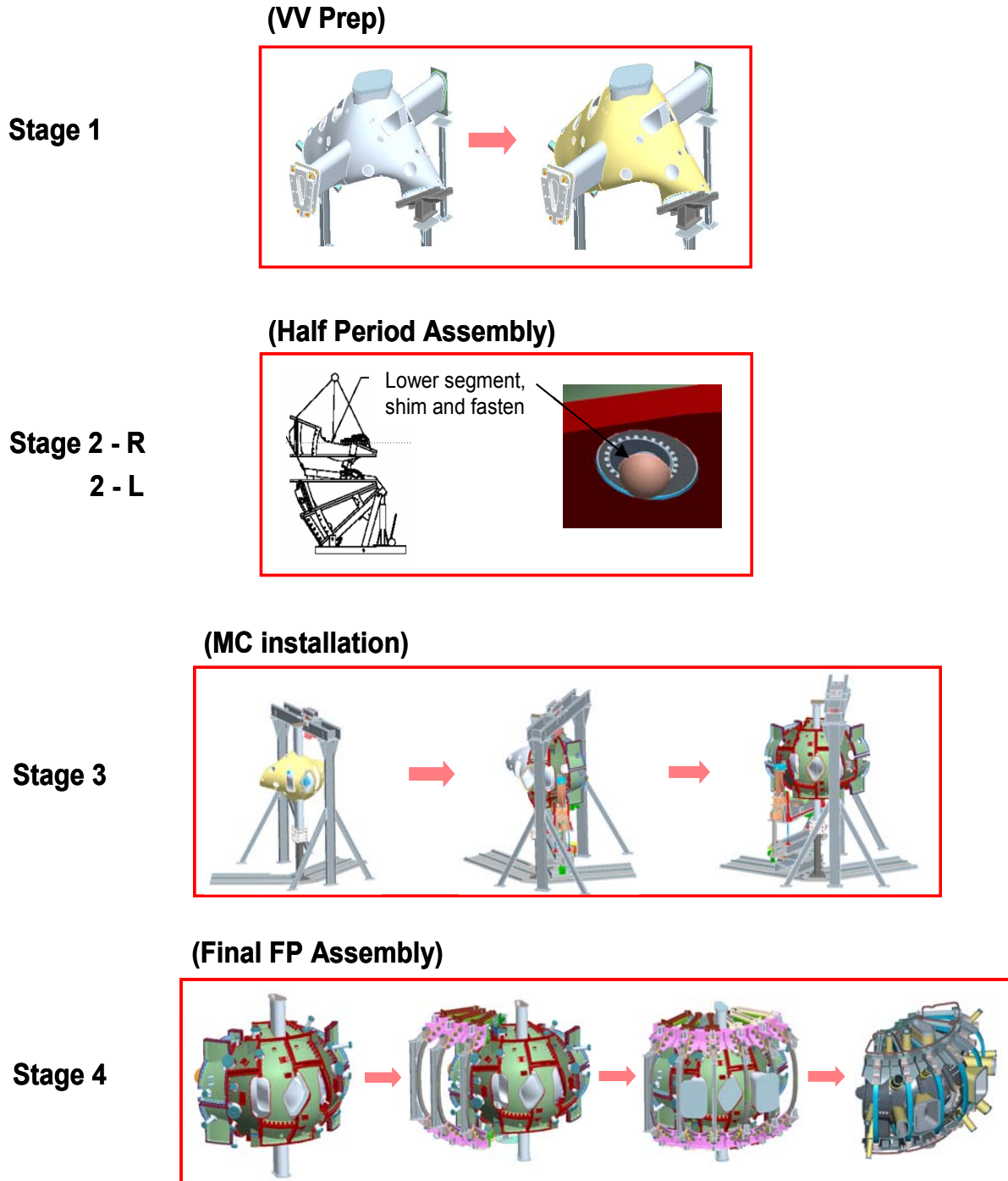

Figure 3 Four Stage Full Period Assembly

ASSEMBLY STEPS

Stage 1 - Vacuum Vessel Preparation

Stage 1 of the Field Period Assembly is the preparation of the vacuum vessel. This involves installing magnetic loops and/or saddle coils, cooling/heating trace lines and thermal insulation. The vessel orientation was shown in a vertical direction in the PDR, see Figure 4a. I did an assessment of this orientation and felt that a horizontal orientation (shown in Figure 4b) would offer assembly advantages with regard to platform construction and overall vacuum vessel access. I've shown the vacuum vessel supported from the shell ends and from one of the vertical ports. The vertical port that will be the bottom is left unsupported so that an alignment plate can be attached to it. The alignment plate will be adjusted to accurately define the orientation of the vacuum vessel when ultimately assembled in the modular coil turning fixture.

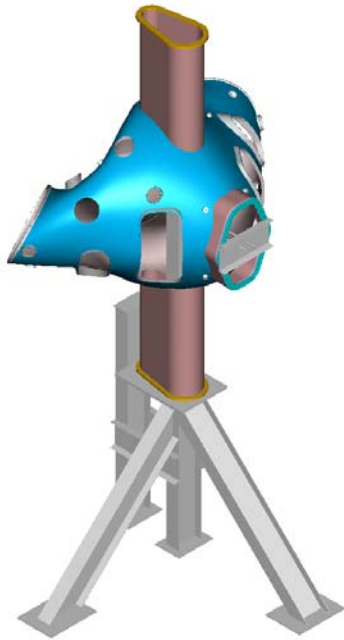

Figure 4a) PDR VV Orientation

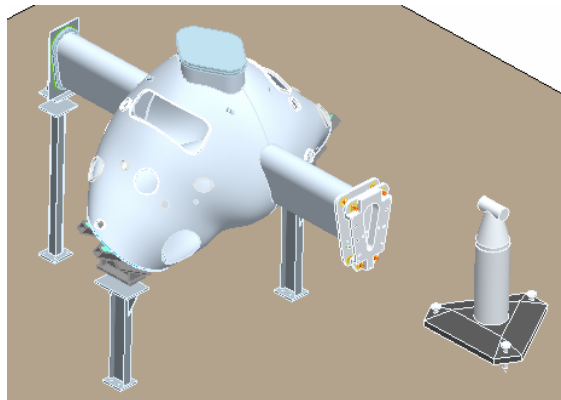

Figure 4b) Proposed New VV Orientation

Figure 4 Stage 1 Assembly

The Leica laser tracker system is shown to signify that metrology measurements will be used to set the position of the alignment plate. In the details of the assembly design the position of the laser tracker and any additional support stands will need to be identified to assure that full viewing of the vacuum vessel monuments can be made. After the alignment plate is set I show (in Figure 5) platforms being brought in to provide access to the vacuum vessel upper surface. Figure 6 shows the platform joined with man access below and above the platform and continuity provided in the gap between the platform and the vacuum vessel shell. I did not alter the 39 day timeline estimates for the tasks associated with the Stage 1 vacuum vessel preparation as defined in the PDR.

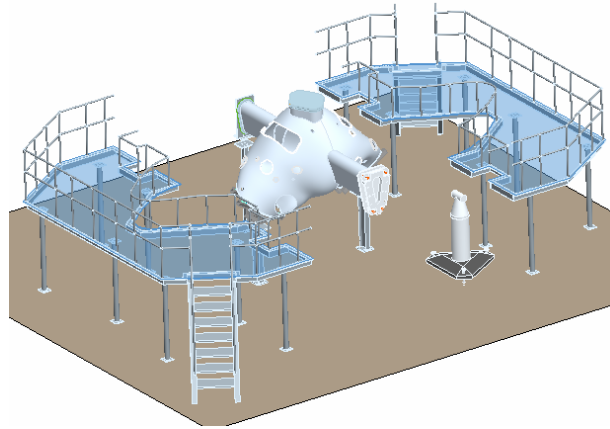

Figure 5 Assembly platforms installed

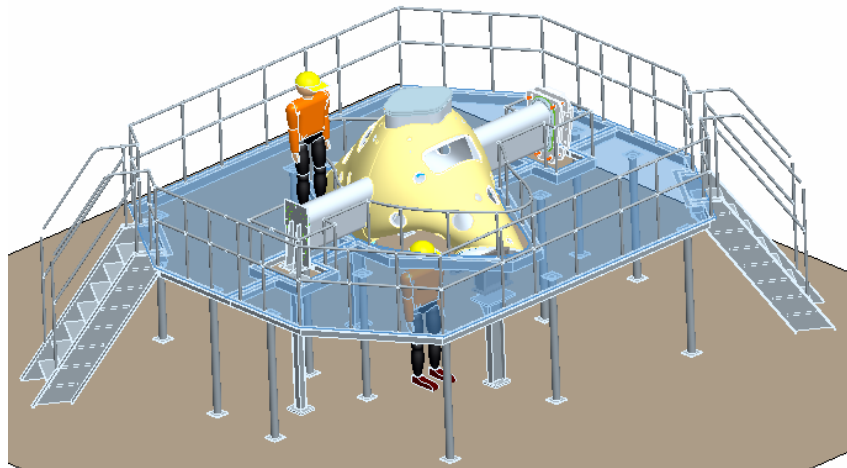

Figure 6 Platform in place to complete assembly

Stage 2 – Half Period Assembly

I have assumed that the dimensional inspection involved with the manufacturing of the modular coil shells and the metrology data collection during the winding process has been accounted for in the Modular Coil Casting Fab task (job 1411) and/or in the Winding/VPI tasks (job 1423). I believe that this was the same assumption made for the PDR field period assembly report. The assembly of the half period is then tasked to provide accurately assembled set of windings of Type A, B and C that are bolted together in an assembly fixture (as shown in Figure 7), ready for assembly in the modular coil turning fixture.

I saw the need of a separate holding fixture (not shown in Figure 7) that would be used to support the individual module coils to allow for dimensional inspection and the attachment of three concentric ball adjustment locators (shown in a local detail in Figure 7). A Leica laser tracker will be needed to position the concentric balls so that a best fit alignment of the module coil can be established in the full half period assembly. It seemed to me that we need to have the mating Type C and Type A module coils available and dimensionally inspected, in addition to the three that make up the half period set, in order to accurately set the mating concentric ball adjustment fittings. I have these steps listed in the timeline of Table 1. After the alignment ball adjustment fittings are set the module coils are loaded on the half period assembly fixture and (except for Type C – first to be assembled) are matted with

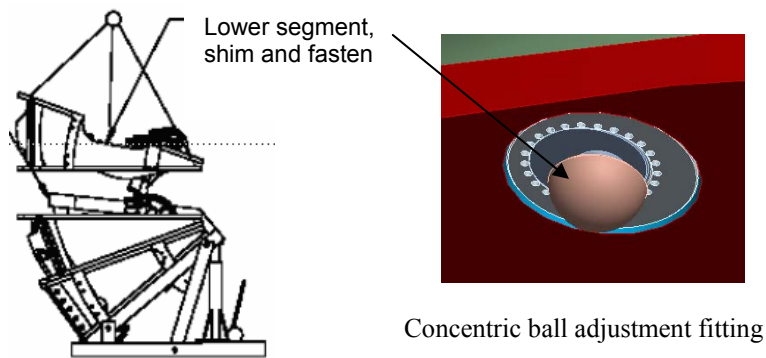

Figure 7 Half Period Assembly

the previously assembled module coil. This assembly approach has merit in that there is no requirement for the assembly fixture to be built with mechanisms to adjust the position of the module coil. Also, the assembly approach can be demonstrated very early; the concentric ball adjustment fitting can be fabricated, test assemblies can be made and the accuracy / repeatability of the system defined. One area of risk that I see for the timeline involves the flange shim definition and installation. After each module coil is placed on the assembly stand and metrology position checks are made to assure its positional accuracy, the gap between flanges must be measured (or a gap impression made) in order to fabricate shims. After the shims are made the mating parts are separated and the shims are put in place; the flanges are bolted together and metrology measurements are retaken to assure that the coil positional accuracy is maintained. The details of the shimming process needs to be further developed to assure that it can be done in a timely manner.

I show a Stage 2-L in the field period assembly pictorial and timeline to indicate that the left side half period needs one less step in its assembly.

Stage 3 – Module Coil Installation

The review and details of the module coil turning fixture has been covered earlier in this report. The timeline set for this stage covers ten steps. I felt that if the turning fixture was demonstrated and well characterized early then the process of rotating the module coils over the vacuum vessel would not take a great deal of time. The greatest time risk in this stage of the assembly process is the ability to maintain the accuracy of the module coil when the load is transferred to the gantry crane and (as in the half period assembly stage) installing the shims; namely the time required to measure, fabricate, install shims and reconfirm the parts positional accuracy. If we demonstrate these processes early the risks can be minimized.

Stage 4 – Final Field Period Assembly

As stated earlier, I feel that a fourth stage is needed in the field period assembly process. I have a crude model started but not completed for this report. Figure 8a shows the position of the initial placement of the left TF three coil assembly and Figure 8b shows the left TF three coil assembly in place. In reviewing the TF assembly it showed that there were no interferences with the vacuum vessel ports except for the horizontal diagnostic port. It seems that there may be an advantage with increased space and reduced restrictions to weld the unaffected ports to the vacuum vessel before the TF is assembled. The horizontal diagnostic port can be attached after the TF system is assembled. I have reflected this assembly approach in the Stage 4 timeline.

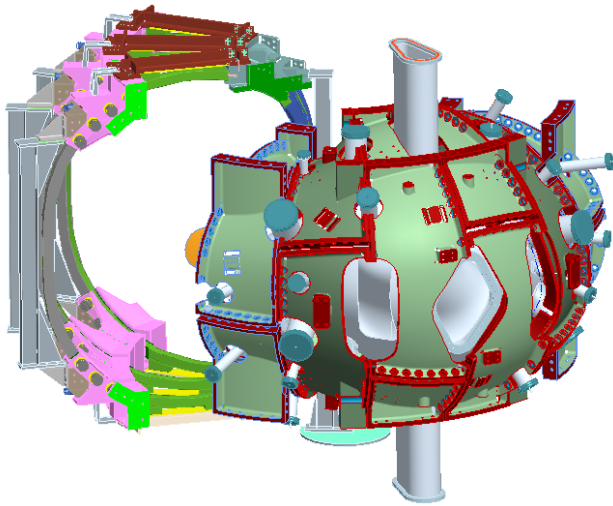

Figure 8a) Initial TF Placement

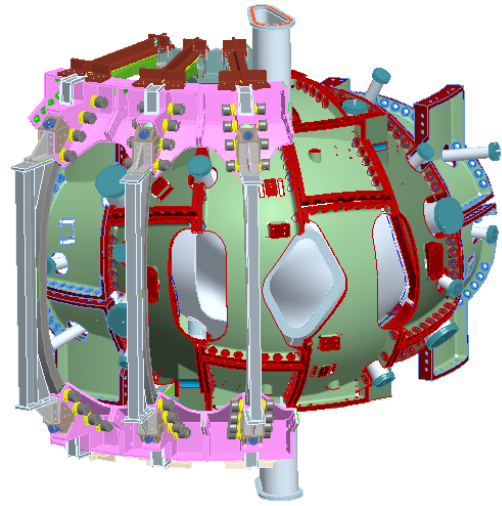

Figure 8b) TF Assembly

Figure 8 Field Period Assembly

Table 1 Field Period Assembly Steps

Field Period Assembly Steps		Days
Stage 1 (VV Prep) Not a critical path task		39
1	Receive VV, inspect and test	
2	Mount to installation fixture and align temporary support base.	
3	Mount magnetic diagnostic sensors to surface.	
4	Install cooling/heating lines to vacuum vessel surface	
5	Install insulation to vacuum vessel	
Stage 2 - R (MC Half Period Assembly - Right side)		26
1	Mount mating Type C in holding fixture; take metrology measurements to define part orientation; mark and store for next period	2
2	Mount another Type C assembly in holding fixture, take metrology measurements to define part orientation and make C to C tooling ball adjustments	2
3	Mount Type C in half period assembly fixture; tilt fixture to accept Type B	1
4	Mount Type B in holding fixture; take metrology measurements to define part orientation; make B to C tooling ball adjustments	2
5	Mount Type B in half period assembly fixture; tilt fixture to accept Type A	0.5
6	Take C to B gap measurements; fabricate shims	5
7	Separate C and B as required to install shims; bolt together; perform metrology position check	2
8	Mount Type A in holding fixture; take metrology measurements to define part orientation; make A to B tooling ball adjustments	2
9	Mount Type A in half period assembly fixture;	0.5
10	Take B to A gap measurements; fabricate shims	5
11	Separate B and A as required to install shims; bolt together; perform metrology position check	2
12	Mount mating Type A in holding fixture; take metrology measurements to define part orientation; make A to A tooling ball adjustments; mark and store for next period	2
Stage 2 - L (MC Half Period Assembly - Left side)		24
1	Mount mating Type C in holding fixture; take metrology measurements to define part orientation; mark and store for next period	2
2	Mount another Type C assembly in holding fixture, take metrology measurements to define part orientation and make C to C tooling ball adjustments	2
3	Mount Type C in half period assembly fixture; tilt fixture to accept Type B	1
4	Mount Type B in a holding fixture; take metrology measurements to define part orientation; make B to C tooling ball adjustments	2
5	Mount Type B in half period assembly fixture; tilt fixture to accept Type A	0.5
6	Take C to B gap measurements; fabricate shims	5
7	Separate C and B as required to install shims; bolt together; perform metrology position check	2
8	Mount Type A in holding fixture; take metrology measurements to define part orientation; make A to B tooling ball adjustments	2
9	Mount Type A in half period assembly fixture;	0.5
10	Take B to A gap measurements; fabricate shims	5

- | | | |
|----|--|---|
| 11 | Separate B and A as required to install shims; bolt together; perform metrology position check | 2 |
| 12 | Not needed for left side half period | |

Stage 3 (MC installation)

- | | | |
|----------------------------------|---|-----------|
| Stage 3 (MC installation) | | 20 |
| 1 | Mount VV to MC turning fixture assembly | 1 |
| 2 | Rotate right MC to stand-off position | 1 |
| 3 | Check position, transfer load to gantry crane and recheck position | 2 |
| 4 | Move MC turning fixture to left side and mount left side MC | 1 |
| 5 | Rotate left MC to stand-off position and check position | 2 |
| 6 | Move left and right MC to final position and take gap measurements for shim fabrication | 5 |
| 7 | Back off left and right MC's slightly to install shims. | 2 |
| 8 | Move MC's to final position with shims in place; perform metrology position check | 2 |
| 9 | Bolt left and right MC's at interface; perform metrology position check | 2 |
| 10 | Assemble VV support hardware to MC structure and attach VV to MC's | 2 |

Stage 4 (Final FP Assembly)

- | | | |
|------------------------------------|--|-----------|
| Stage 4 (Final FP Assembly) | | 60 |
| 1 | Mount MC/VV assembly to support frame at final assembly station | 1 |
| 2 | Position and weld all ports to VV except for the two large horizontal diagnostic ports | 10 |
| 3 | Assemble right TF Coil Assembly | 1 |
| 4 | Assemble left TF Coil Assembly | 1 |
| 5 | Attach TF coils to MC's | 2 |
| 6 | Position and weld two large horizontal diagnostic ports to VV | 5 |
| 7 | Bakeout VV to 150 deg C and leak check | 26 |
| 8 | Assemble external trim coils to TF Coil | 5 |
| 9 | Using metrology measurements adjust final support base interfaces | 2 |
| 10 | Prepare Field Period for shipment | 2 |
| 11 | Ship Field Period | 1 |
| 12 | Field Period ready for installation | 4 |
| | - place Field Period on device core radial support system (1 day) | |
| | - perform metrology measurements to assure final alignment (3 days) | |

Total Elapse Time **169**