

MC Shell NBI port cut
 dimension change on
 part # s17e172-017

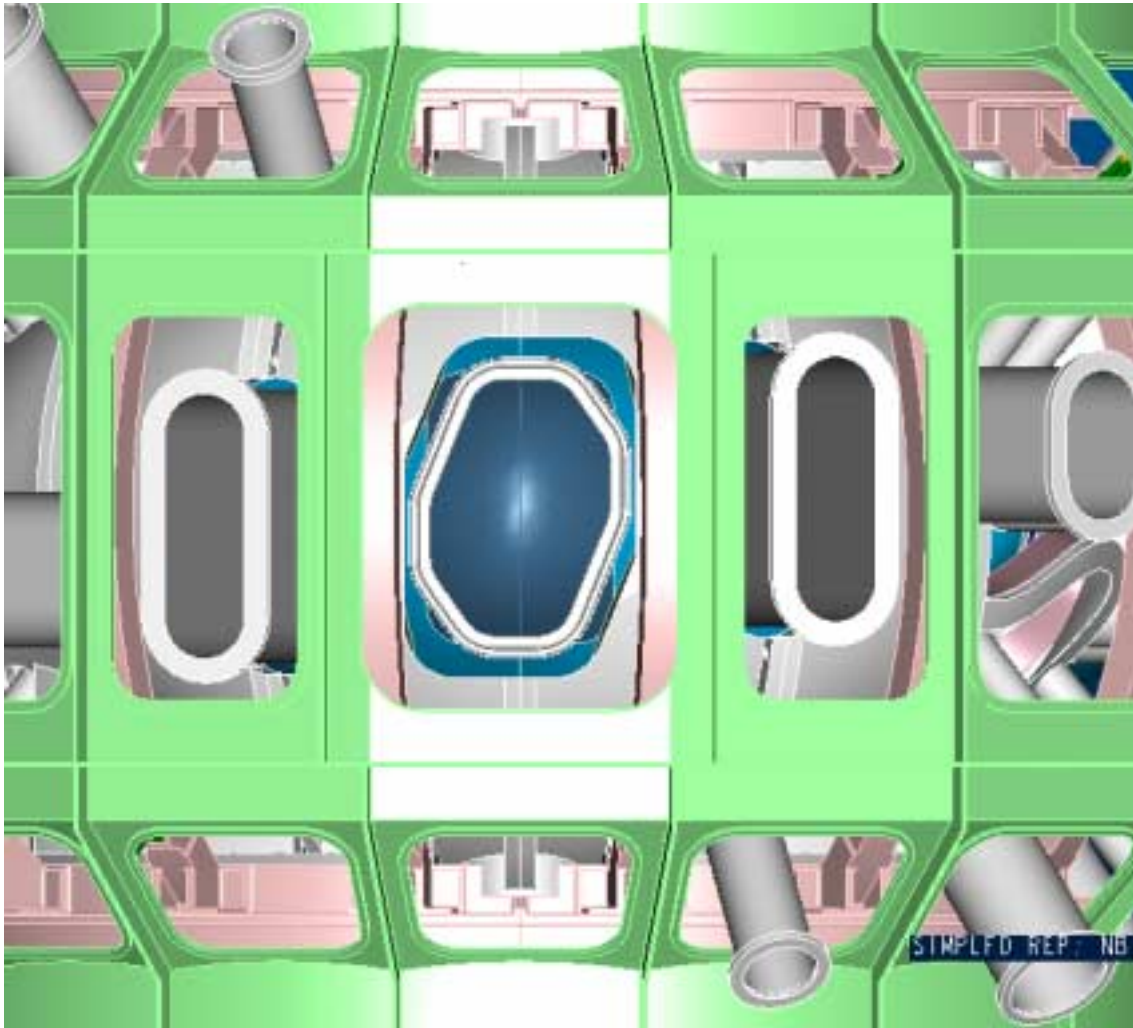

The modular coil shell opening and NBI port were reshaped to eliminate port interference with modular coils.

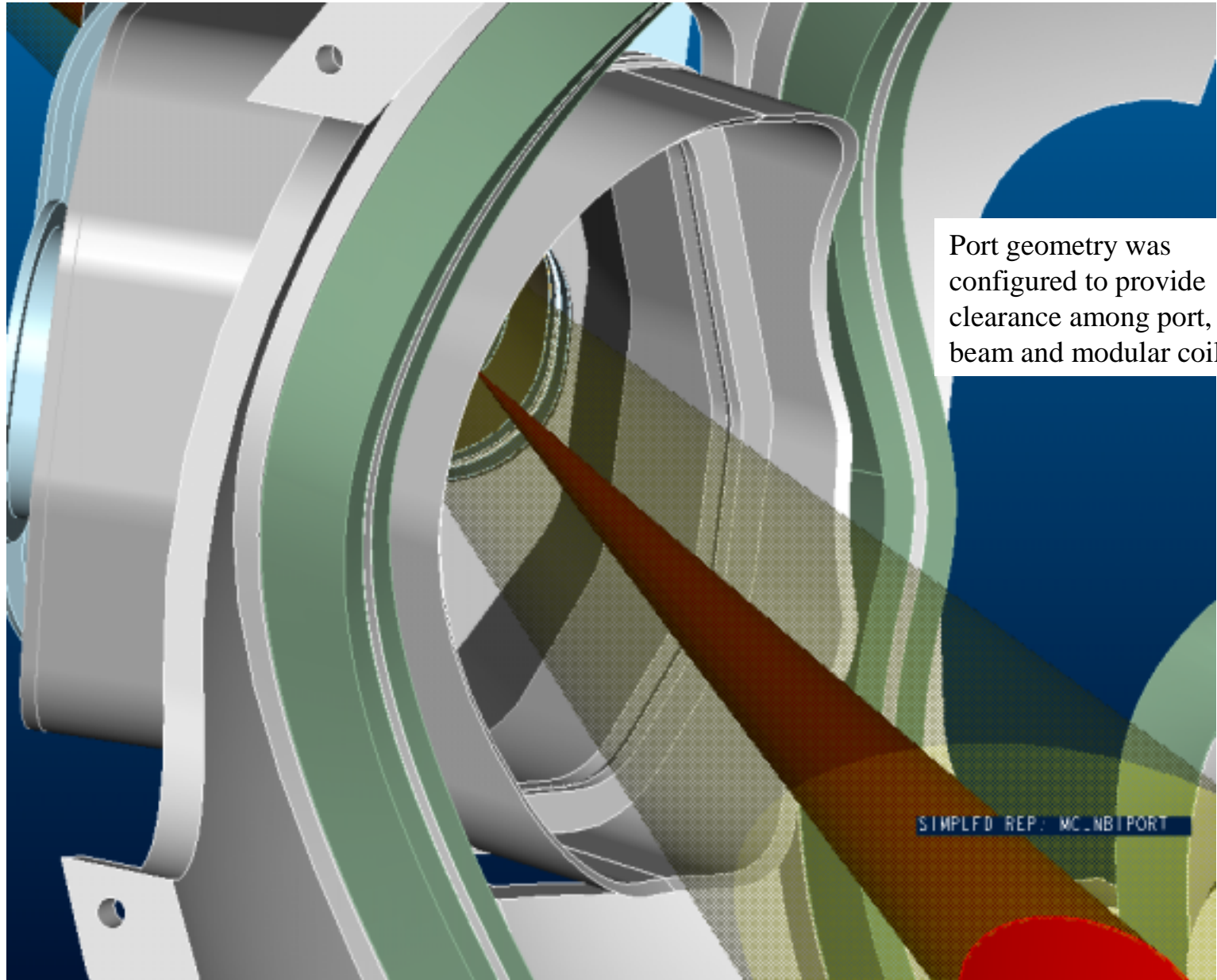

Port geometry was configured to provide clearance among port, NBI beam and modular coil.

SIMPLFD REP: MC_NBI PORT

S17E122-009.ASM

Manned Access
(14" x 25")

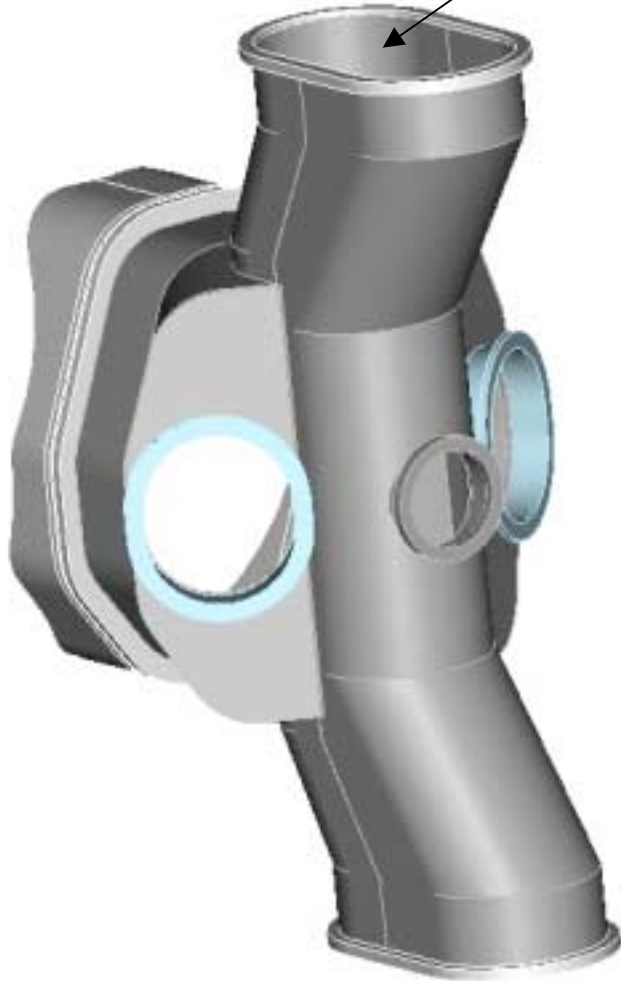

S17E122-056.PRT
which is a part of -
009.asm

S17E122-008.ASM

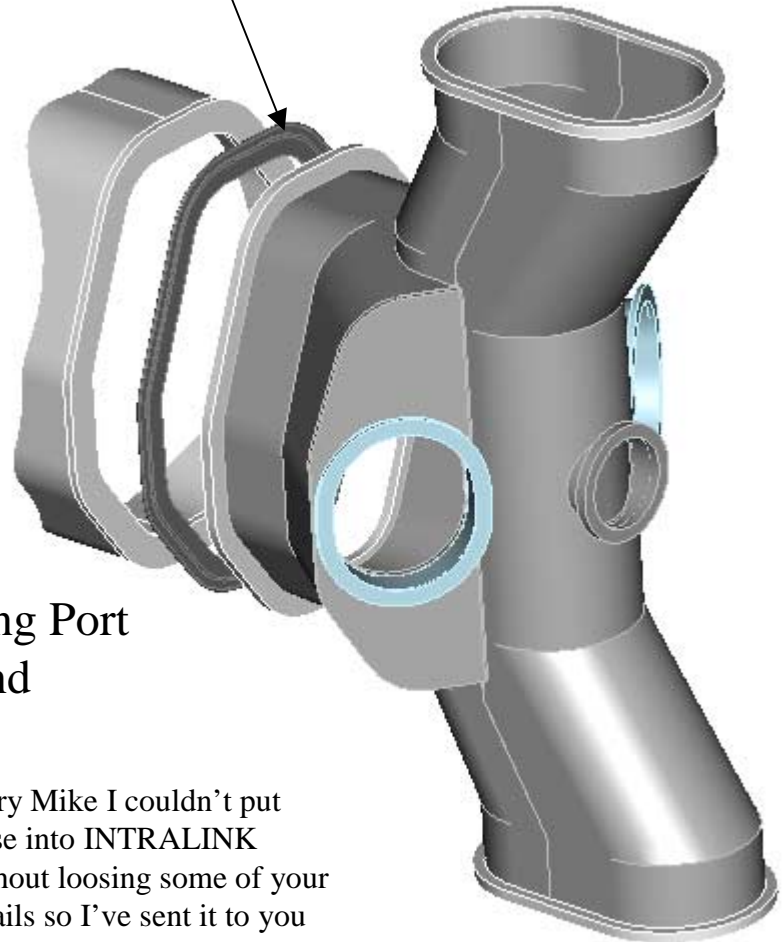

Pumping Port
end

NBI Port Assembly

Sorry Mike I couldn't put these into INTRALINK without losing some of your details so I've sent it to you offline. You'll need to make some number changes.

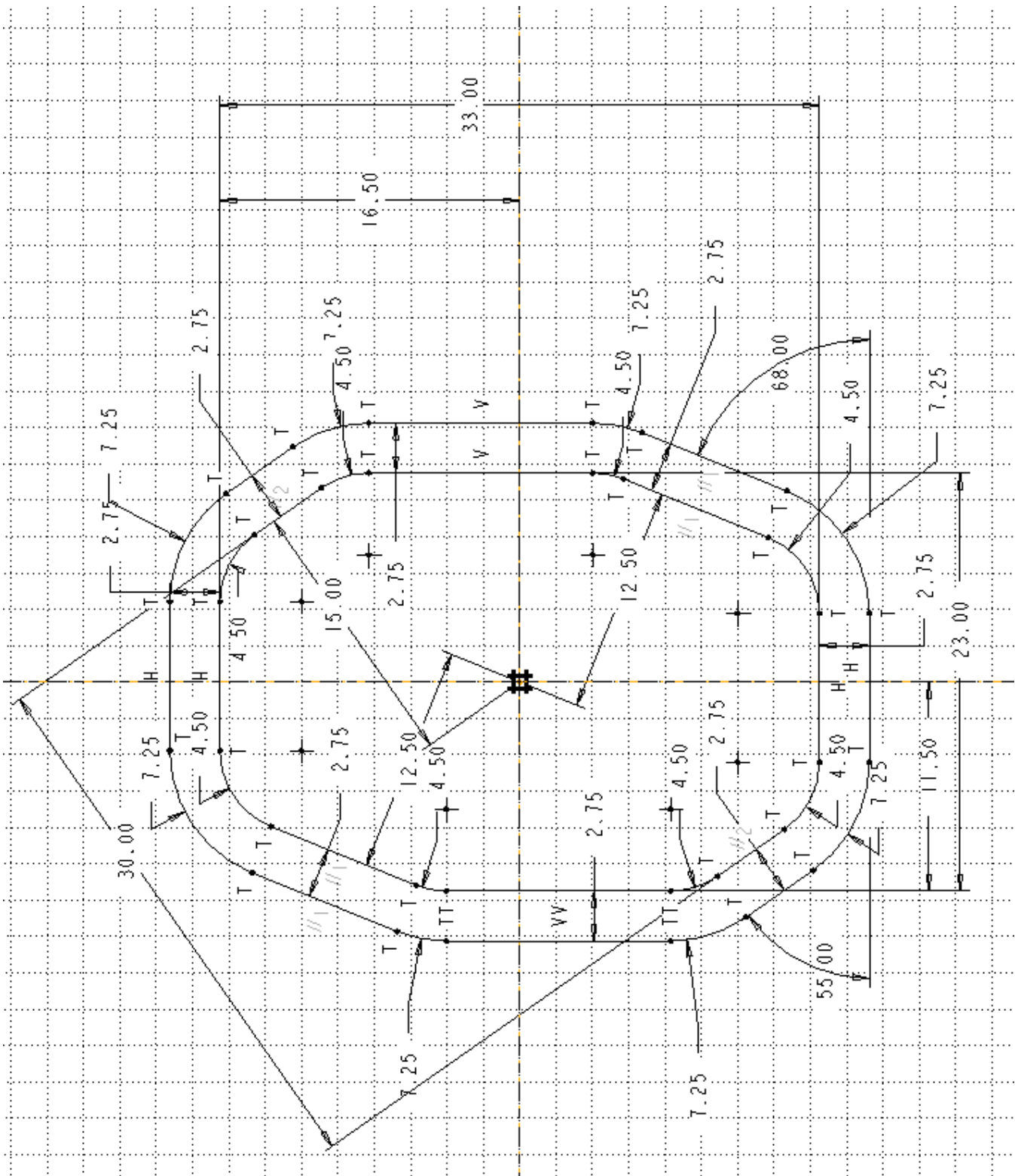

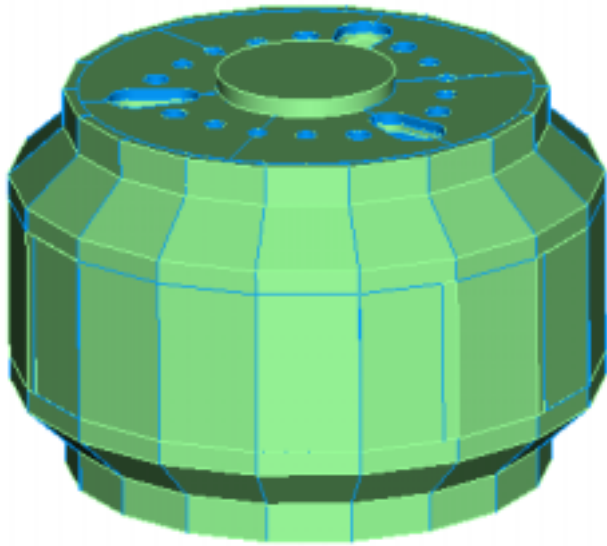

S17e150-005.asm

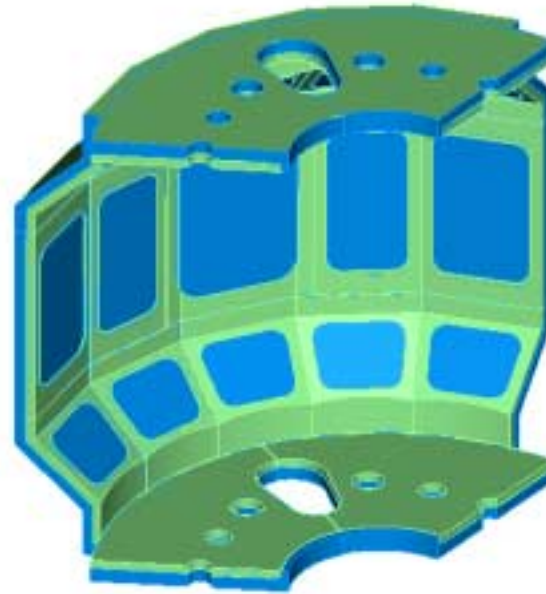

S17e150-006.asm

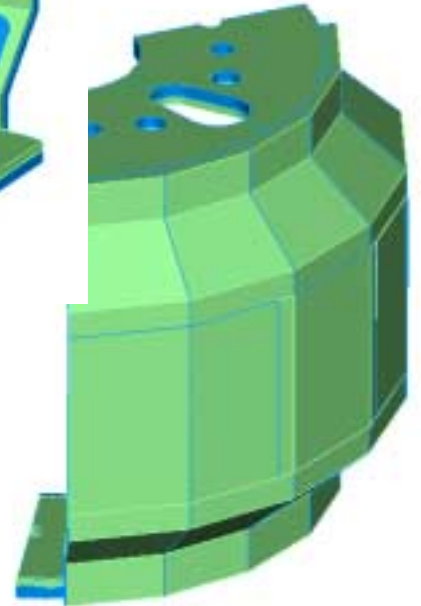

THERMAL SHIELD

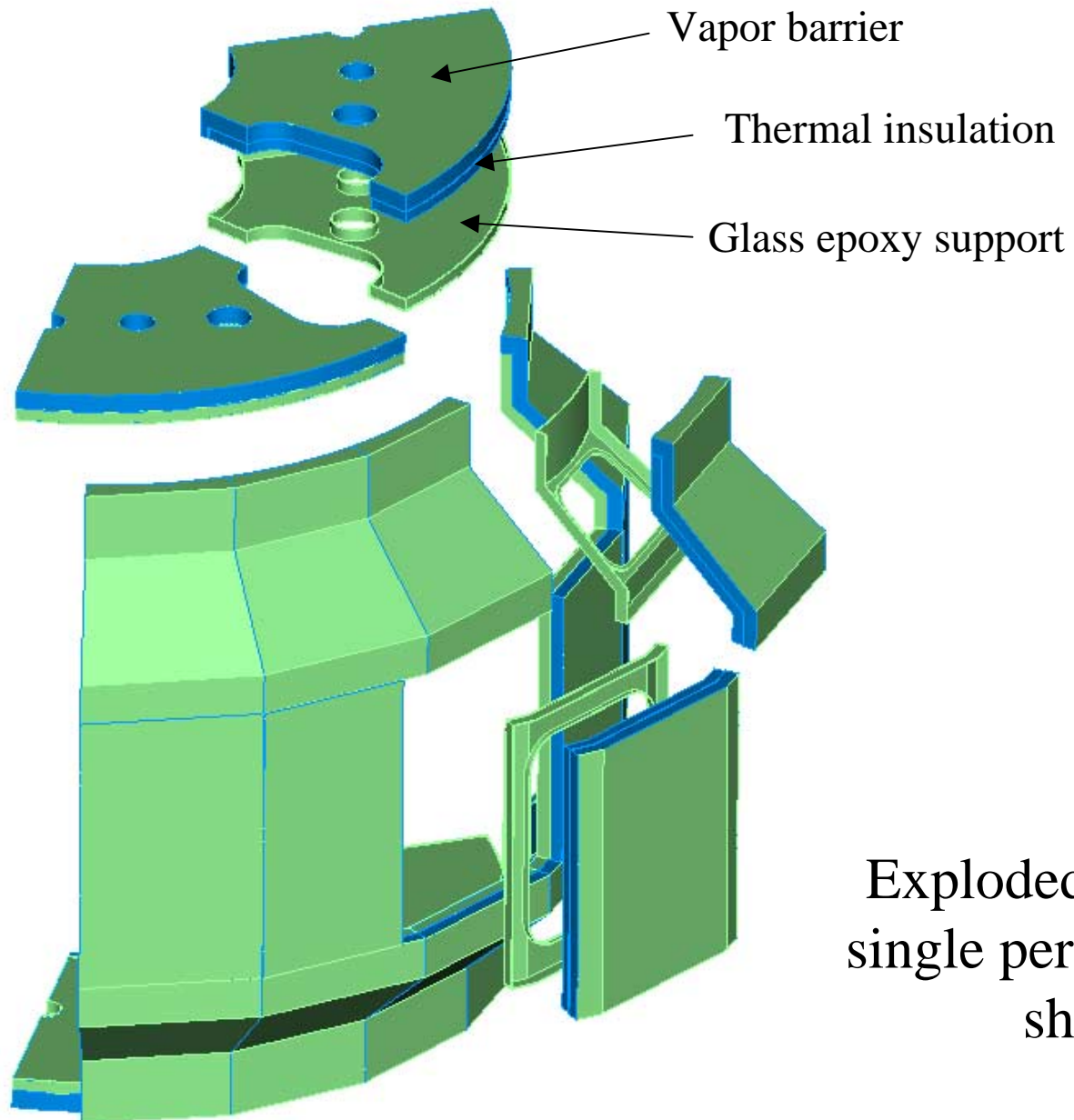

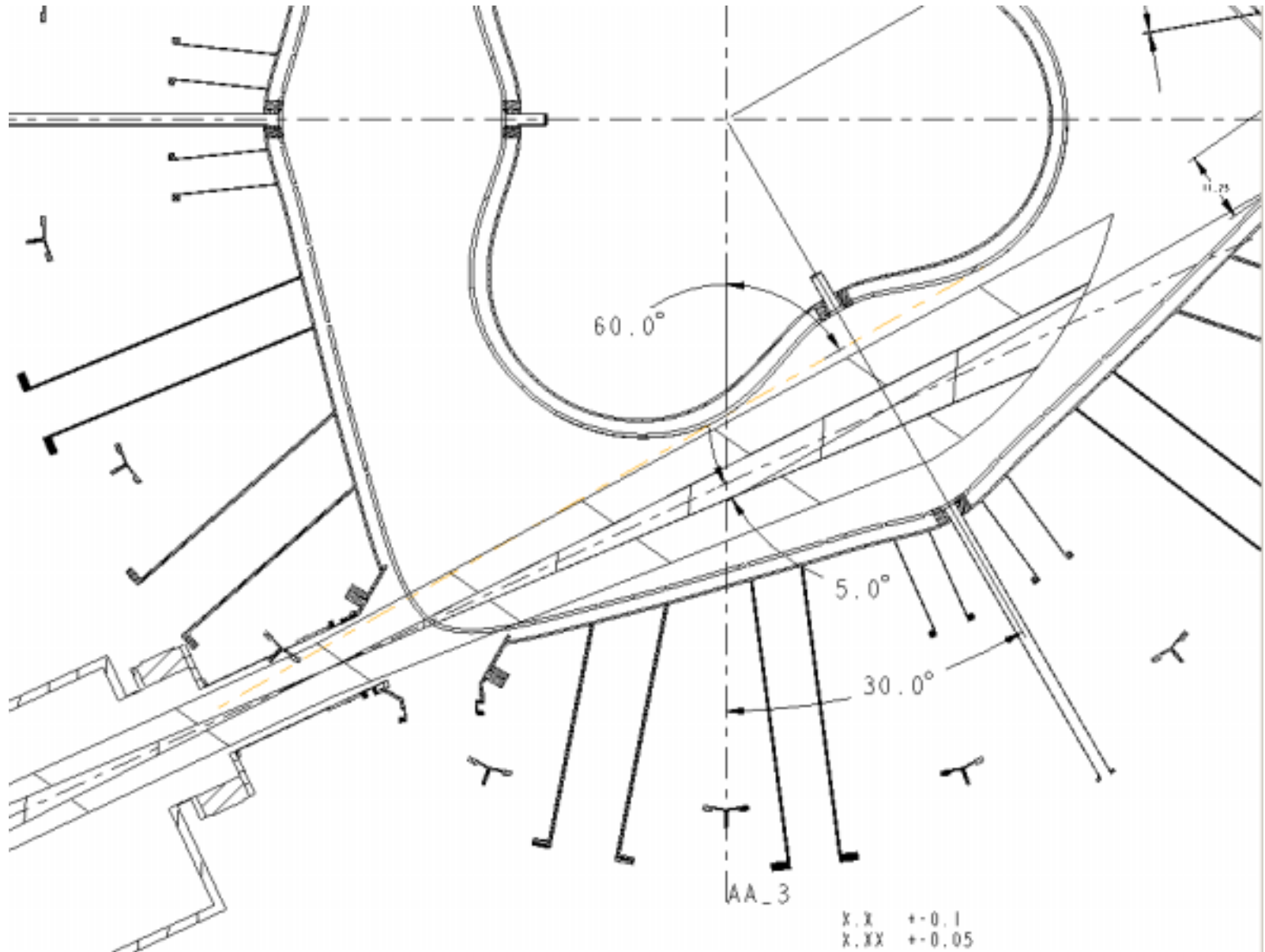

Baseline NBI position

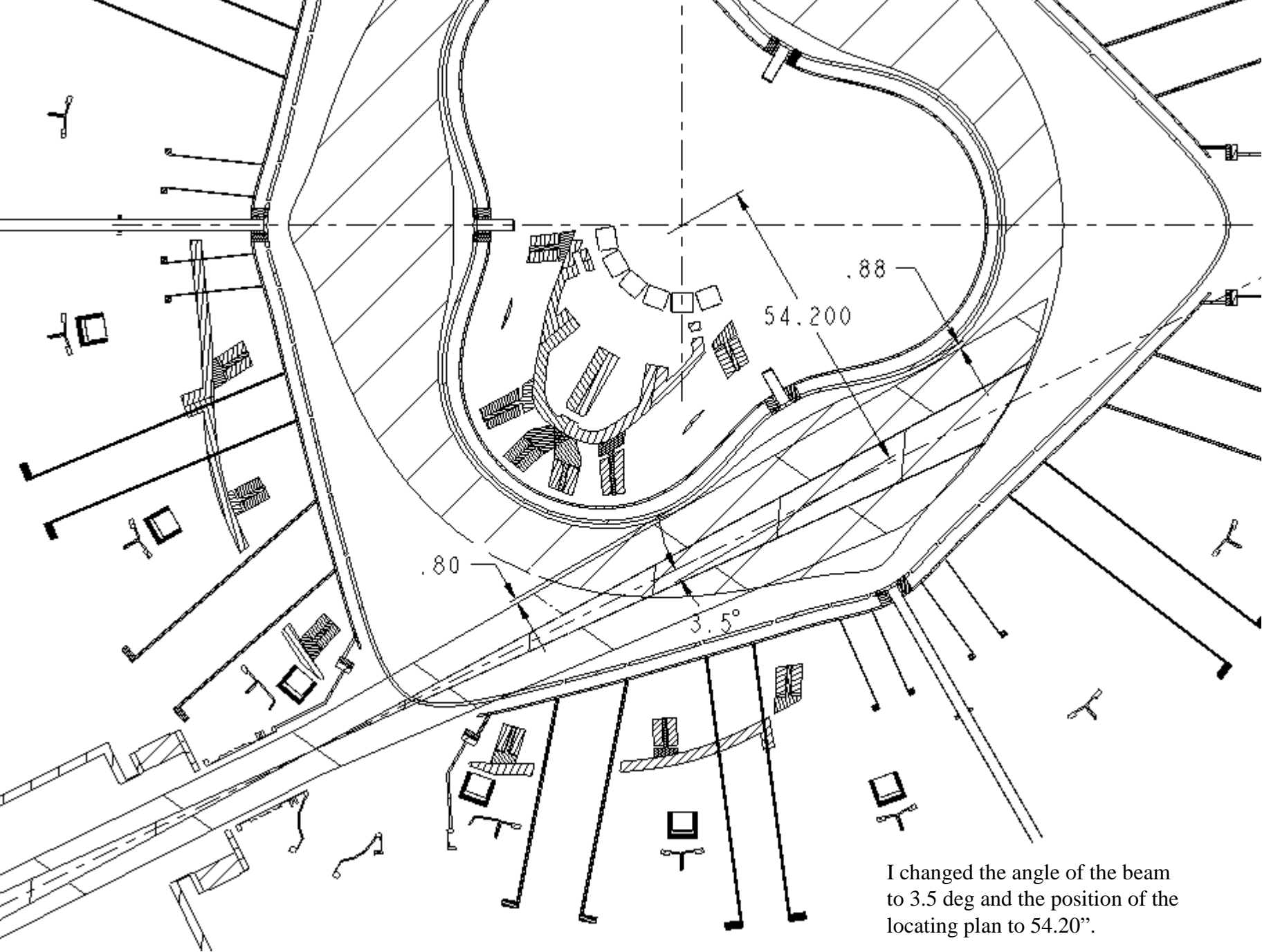

I changed the angle of the beam to 3.5 deg and the position of the locating plan to 54.20".

