

# NCSX

## Product Specification For The Modular Coil Type C Assembly

**NCSX-CSPEC-142-05-00**

**14 November 2005**

Prepared by: \_\_\_\_\_

D. Williamson, Modular Coil System (WBS 14) Manager

Concur: \_\_\_\_\_

J. Chrzanowski, ATI for Modular Coil Fabrication

Concur: \_\_\_\_\_

L. Dudek, RLM for Modular Coil Fabrication

Concur: \_\_\_\_\_

B. Nelson, RLM for Stellarator Core Systems (WBS 1) Design and Procurement

Concur: \_\_\_\_\_

F. Malinowski, Quality Assurance

Concur: \_\_\_\_\_

J. Levine, ES&H

Approved by: \_\_\_\_\_

W. Reiersen, Engineering Manager

**Controlled Document**

*This is a controlled document. Check the NCSX Engineering Web prior to use to assure that this document is current.*

**Record of Revisions**

---

Revision	Date	ECP	Description of Change
Rev. 0	11/14/05	---	Initial Release

---

## Table of Contents

<b>1</b>	<b>Scope</b> .....	<b>1</b>
<b>2</b>	<b>Applicable Documents</b> .....	<b>1</b>
2.1	NCSX Documents .....	1
2.2	Other Documents.....	1
<b>3</b>	<b>Requirements</b> .....	<b>1</b>
3.1	Item Definition .....	1
3.2	Characteristics .....	3
3.2.1	Performance.....	3
3.2.1.1	Design Verification.....	3
3.2.1.2	Timeline for Coil Cool-down to Cryogenic Temperature.....	4
3.2.1.3	Coil Warm-up Timeline.....	4
3.2.1.4	Pre-Pulse Temperature.....	4
3.2.1.5	Field Error Requirements .....	4
3.2.1.5.1	Poloidal Electrical Breaks .....	4
3.2.1.5.2	Winding Tolerance.....	4
3.2.1.6	Reference Scenario Requirements .....	5
3.2.1.7	Pulse Repetition Rate.....	5
3.2.1.8	Electrical Requirements.....	5
3.2.1.8.1	Electrical Isolation of the Conductor .....	5
3.2.1.8.2	Turn-to-turn Voltage Standoff .....	5
3.2.1.8.3	Electrical Isolation and Grounding of Other Components .....	5
3.2.1.8.4	Electrical Resistance .....	6
3.2.2	Physical Characteristics .....	7
3.2.2.1	Winding Form.....	7
3.2.2.2	Attachments .....	7
3.2.2.3	Winding Packs .....	7
3.2.2.3.1	Cladding.....	7
3.2.2.3.2	Chill Plates and Coolant Tubes.....	7
3.2.2.3.3	Conductor .....	7
3.2.2.3.4	Ground Insulation .....	7
3.2.2.3.5	Lead Blocks .....	7
3.2.2.3.6	Terminal Assembly.....	8
3.2.2.3.7	Clamps .....	8
3.2.2.3.8	Co-wound Diagnostic Loops .....	8
3.2.2.3.9	Instrumentation .....	8
3.2.2.3.10	Bag Mold Assembly .....	8

3.2.2.4	Weight .....	8
3.2.3	System Quality Factors .....	8
3.2.3.1	Reliability, Availability, and Maintainability .....	8
3.2.3.2	Design Life .....	9
3.2.4	Transportability .....	9
3.2.5	Interface Requirements .....	9
3.2.5.1	Vacuum Vessel System (WBS 12) Interface Requirements .....	9
3.2.5.2	Conventional Coils (WBS 13) Interface Requirements .....	10
3.2.5.3	Coil Support Structures (WBS 15) Interface Requirements .....	10
3.2.5.4	Liquid Nitrogen Distribution System (WBS 161) .....	10
3.2.5.5	Electrical Power Systems (WBS 4) .....	10
3.2.5.6	Central I&C (WBS 5) .....	11
3.3	Design and Construction .....	11
3.3.1	Materials, Processes, and Parts .....	11
3.3.1.1	Production Drawings .....	11
3.3.1.2	Magnetic Permeability .....	11
3.3.1.3	Corrosion Prevention and Control .....	11
3.3.1.4	Flammable Materials .....	11
3.3.1.5	Metrology .....	11
3.3.2	Labels .....	12
3.3.3	Workmanship .....	12
3.3.4	Interchangeability .....	12
<b>4</b>	<b>Quality Assurance Provisions.....</b>	<b>12</b>
4.1	General .....	12
4.2	Verification Methods .....	12
4.3	Quality Conformance .....	13
4.3.1	Verification of Design Verification Requirement.....	13
4.3.1.1	Verification of Coil Cool-down and Warm-up Timelines .....	13
4.3.1.2	Verification of Pre-Pulse Temperature .....	13
4.3.1.3	Verification of Field Error Requirements .....	13
4.3.1.3.1	Verification of the Poloidal Electrical Breaks.....	13
4.3.1.3.2	Verification of Winding Tolerance .....	13
4.3.1.4	Verification of Reference Scenario Requirements.....	13
4.3.1.5	Verification of Pulse Repetition Rate .....	14
4.3.1.6	Verification of Electrical Requirements .....	14
4.3.1.6.1	Verification of Electrical Isolation of the Conductor.....	14
4.3.1.6.2	Verification of Turn-to-turn Voltage Standoff.....	14

4.3.1.6.3 Verification of Electrical Isolation and Grounding of Other Components ..... 14

4.3.1.6.4 Verification of Electrical Resistance..... 14

4.3.2 Verification of Physical Characteristics ..... 14

4.3.2.1 Weight ..... 14

4.3.3 Verification of System Quality Factors ..... 15

4.3.3.1 Reliability, Availability, and Maintainability ..... 15

4.3.3.2 Design Life ..... 15

4.3.3.3 Transportability ..... 15

**5 Appendices ..... 16**

5.1 Assembly Models and Drawings ..... 16

5.1.1 Modular Coil Assembly Type C..... 16

**Table of Figures**

**Figure 3-1 Type C Assembly..... 2**

**Figure 3-2 Terminal Assembly Isometric View ..... 3**

**Figure 3-3 Electrical isolation and grounding of coolant loops ..... 6**

## **1 SCOPE**

The Modular Coil System (WBS 14) consists of eighteen (18) modular coils. There are three (3) types of modular coils and six (6) of each type. The three types of modular coils are Type A, Type B, and Type C. This specification defines the modular coil Type C assembly (the Assembly) and requirements for its fabrication.

## **2 APPLICABLE DOCUMENTS**

### **2.1 NCSX Documents**

NCSX-ASPEC-GRD, NCSX General Requirements. This document is referred to herein as the GRD.

NCSX-BSPEC-14-00, System Requirements for the Modular Coil System (SRD)

NCSX-CSPEC-14-01, Product Specification for the Three-Coil Assembly.

NCSX-CSPEC-141-03, Product Specification for the Modular Coil Winding Forms

NCSX-CSPEC-142-03, Product Specification for the Modular Coil Conductor

NCSX-CRIT-CRYO, Structural and Cryogenic Design Criteria

### **2.2 Other Documents**

ASTM A703/M-01, Specification for Steel Castings

ASTM B152/M-00, Standard Specification for Copper Sheet

ASTM B280-03, Standard Specification for Seamless Copper Tube

## **3 REQUIREMENTS**

### **3.1 Item Definition**

The Assembly consists of a winding form with a machined tee profile onto which a coil is wound and is illustrated in Figure 3-1. Major components of the Assembly are listed below.

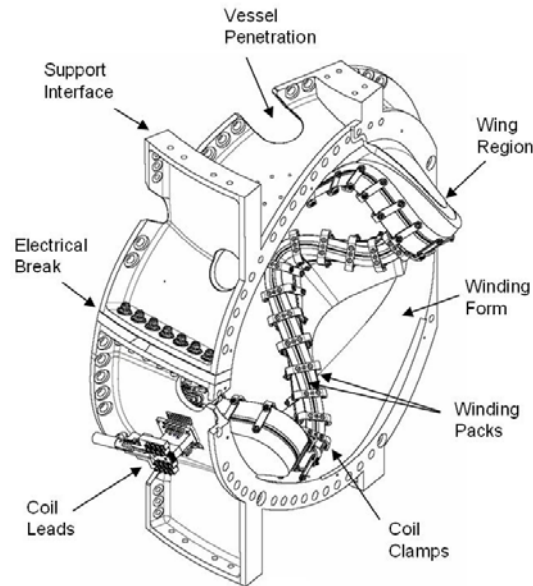

**Figure 3-1 Type C Assembly**

- a. **Winding Form.** The Type C winding form (the Winding Form) is a cast stainless steel structure with a machined “tee” feature. The Product Specification for the Modular Coil Winding Forms (NCSX-CSPEC-141-03) defines the Winding Form and requirements for its fabrication. The Winding Form will be fabricated in industry and delivered to PPPL as a completed assembly.
- b. **Winding Clamp Studs.** After delivery to PPPL, studs will be welded to the base of the tee below the groove used to seal the bag mold. The studs hold the side pieces of the winding clamps during coil fabrication. Special clamp stud adapters will be required in some locations where the side of the base is not parallel to the tee.
- c. **Cladding.** The cladding is a layer of copper that lies against the tee and cools the winding pack by conduction to the chill plates.
- d. **Chill Plates.** The chill plates are the outer layer of copper and coolant tubes for LN<sub>2</sub> cooling. The chill plates are mechanically connected to the cladding.
- e. **Conductor.** The conductor is stranded copper wire compacted into a rectangular cross-section and wrapped in fiberglass insulation. The Product Specification for the Modular Coil Conductor (NCSX-CSPEC-142-03) defines the insulated conductor and requirements for its fabrication. The Conductor will be fabricated in industry and delivered to PPPL on spools ready for coil manufacture.
- f. **Ground Insulation.** The ground insulation consists of epoxy impregnated fiberglass and Kapton tape surrounding the winding pack.
- g. **Lead Blocks.** The lead blocks are insulated supports for conductor entry and exit from winding pack.
- h. **Terminal Assembly.** The Terminal Assembly consists of the hardware required to electrically connect the conductors from Side A winding pack to the Side B winding pack and to the electrical power feed. This hardware includes the base blocks, insulators, jumpers, and lugs. The Terminal Assembly is illustrated in Figure 3-2.

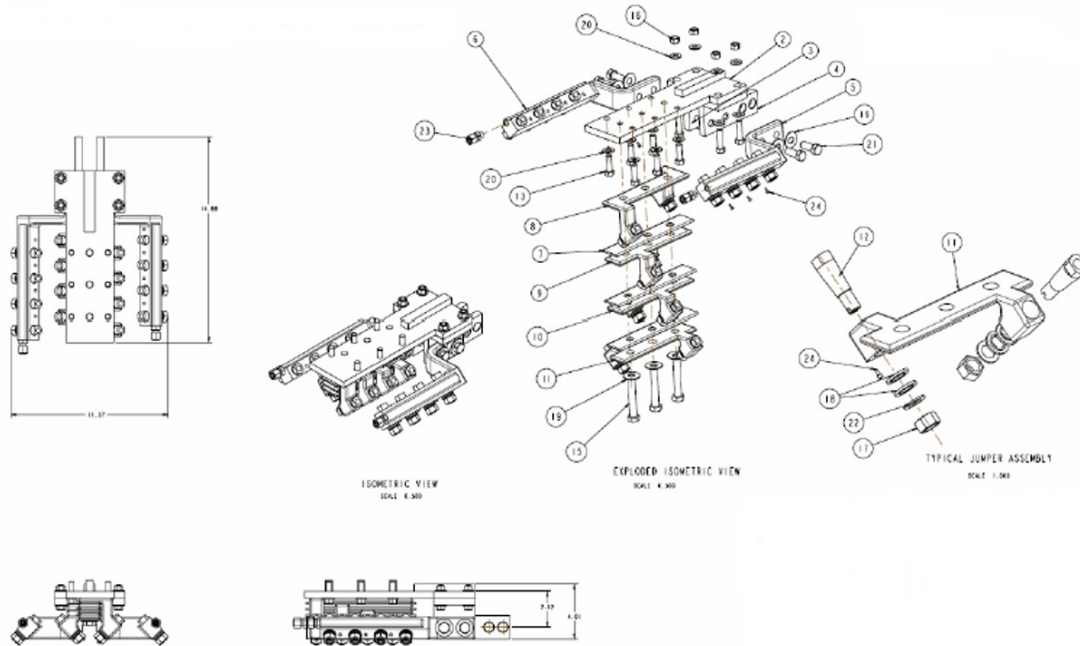

**Figure 3-2 Terminal Assembly Isometric View**

- i. Clamps. There are two sets of clamps. Winding clamps are used to position and hold the winding packs during coil fabrication. Production clamps serve to provide lateral (toward the tee) and vertical (toward the base of the tee) preloads on winding pack.
- j. Co-wound Diagnostic Loops. Two co-wound diagnostic loops are included in the Assembly.
- k. Instrumentation. Assembly instrumentation includes strain gages, thermocouples, and voltage taps.
- l. Bag Mold Assembly. The bag mold consists of strips of self-vulcanizing silicone rubber tape that are used to provide a vacuum barrier around the winding packs for vacuum pressure impregnation (VPI). The bag mold is sealed to the Winding Form at the base of the tee with copper tubing inserted into a groove. G-11CR pads are placed under the bag mold to provide a flat surface for the clamps to push against. The bag mold is sealed by painting it with room temperature vulcanizing silicone (RTV). A chopped fiberglass and epoxy shell is built outside the bag mold to provide structural support during VPI. After VPI, the glass/epoxy shell is removed and the bag mold is cut away from the G-11CR pads. The winding clamps are removed and the production clamps are installed. The G-11CR pads are the only elements of the bag mold assembly that provide a required function for coil operation.

## 3.2 Characteristics

### 3.2.1 Performance

#### 3.2.1.1 Design Verification

The first article shall be instrumented such that key performance parameters (stresses, deflections, temperatures, pressures, etc.) can be measured and compared to calculated values to assure that the Assembly is performing consistent with expectations prior to First Plasma. [Ref. SRD Section 3.2.1.1.1.3 Design Verification]



### 3.2.1.2 Timeline for Coil Cool-down to Cryogenic Temperature

The Assembly shall be capable of being cooled down from room temperature (293K) to the pre-pulse operating temperature within 96 hours with the vacuum vessel at room temperature (20°C). [Ref. SRD Section 3.2.1.2.2.1 Timeline for Coil Cool-down to Cryogenic Temperature]

### 3.2.1.3 Coil Warm-up Timeline

The Assembly shall be capable of being warmed up from operating temperature (80K) to room temperature (293K) within 96 hours. [Ref. SRD Section 3.2.1.3.1 Coil Warm-up Timeline]

### 3.2.1.4 Pre-Pulse Temperature

The Assembly shall return to a pre-pulse temperature of about 80K, so as to prevent overheating during repeated operation. [Ref. SRD Section 3.2.1.2.4]

### 3.2.1.5 Field Error Requirements

#### **Background**

Field errors are a major concern in the design of the modular coils. The fundamental global requirement is that the toroidal flux in island regions due to fabrication errors, magnetic materials, and eddy currents shall not exceed 10% of the total toroidal flux in the plasma (including compensation). To implement this requirement, external trim coils have been provided for field error correction. Poloidal and toroidal electrical breaks are required in the modular coil structure to reduce the size of the eddy current loops and to reduce the longest eddy current time constant in the modular coils such that the calculated field errors are acceptably low. The electrical breaks also facilitate field penetration from the modular and conventional (PF, TF and external trim) coils. The modular coils will be fabricated and assembled to tight tolerances which are calculated to introduce acceptably low field errors (after correction).

#### 3.2.1.5.1 Poloidal Electrical Breaks

- a. A poloidal electrical break shall be provided within each Assembly. [Ref. SRD Section 3.2.1.2.5.1.2a Poloidal Electrical Breaks]
- b. The resistance of the insulation and of the bolt insulation shall be >500 k-ohms when tested at 100 VDC. [Ref. SRD Section 3.2.1.2.5.1.2a Poloidal Electrical Breaks]

#### 3.2.1.5.2 Winding Tolerance

#### **Background**

The requirement for the installed coils is that the local current centroid of each Assembly shall be located within 1.5 mm of the nominal location defined in GRD Section A.1.1 Coil Centroids with the Assembly at the pre-pulse operating temperature with zero current. [Ref. SRD Section 3.2.1.2.5.4]. There are three major steps at which errors can be introduced: [1] coil manufacture; [2] field period assembly; and [3] final machine assembly. In the absence of better knowledge, it was decided to apportion this tolerance equally for each step.

#### **Requirement**

The local current centroid of each Assembly shall be located within 0.5 mm of the nominal location defined in GRD Section A.1.1 Coil Centroids with the Assembly at the pre-pulse operating temperature with zero current.

### 3.2.1.6 Reference Scenario Requirements

#### Background

NCSX is designed to be a flexible, experimental test bed. To ensure adequate dynamic flexibility, a series of reference scenarios has been established. TF, PF, and modular coil systems and the vacuum vessel will be designed for a plasma with a nominal major radius of 1.4 m and capability to meet the requirements of all the reference scenarios. Electrical power systems shall be designed and initially configured to meet the requirements of the First Plasma and Field Line Mapping Scenarios and shall be capable of being upgraded to meet the requirements of all other reference scenarios.

Reference scenario definitions are provided in Section 3.2.1.5.3.3.1 of the General Requirements Document. Reference waveforms of engineering parameters such as coil currents, voltages, power dissipation, etc. are derived from the scenario specifications and are documented in GRD Appendix A.

#### Requirement

The Assembly will be designed to meet the requirements of all the reference scenarios. [Ref. SRD Section 3.2.1.2.6.2 Reference Scenario Requirements]

### 3.2.1.7 Pulse Repetition Rate

The Assembly shall be designed for pulses to be initiated at intervals not exceeding 15 minutes when constrained by coil cooldown and 5 minutes otherwise. [Ref. SRD Section 3.2.1.2.7 Pulse Repetition Rate]

### 3.2.1.8 Electrical Requirements

#### 3.2.1.8.1 Electrical Isolation of the Conductor

The Assembly shall provide the following voltage standoff capability between the electrical circuit (conductor) and all other components outside the electrical circuit.

- a. **Maximum Operating Voltage.** The maximum operating voltage is 2kV.
- b. **Field Maintenance Test Voltage.** The field maintenance test voltage shall be twice the maximum operating voltage to ground plus 1 kV, i.e. 5kV.
- c. **Manufacturing Test Voltage.** The manufacturing test voltage shall be 1.5 times the field maintenance test voltage, i.e. 7.5kV.
- d. **Design Voltage Standoff.** The design voltage standoff shall be twice the manufacturing test voltage, i.e. 15kV.

#### 3.2.1.8.2 Turn-to-turn Voltage Standoff

The Assembly shall be designed to provide a design voltage standoff from one turn of conductor to any adjacent turn of conductor of 600V which is approximately thirty-six times the maximum turn-to-turn voltage of 16.7V.

#### 3.2.1.8.3 Electrical Isolation and Grounding of Other Components

Electrical isolation and grounding requirements for components of the Assembly other than the conductor are listed below. The resistance of the electrical isolation features (e.g. electrical breaks in the coolant tubes and Kapton sheets on the cladding) shall be greater than 10 MOhms when tested at 1 kVDC. High resistance grounds shall have a resistance of 100 ohms (TBR).

- a. Winding form. The winding form is connected to a high resistance, single point ground.

- b. Clamps. The production clamps are electrically connected to the winding form through their mechanical attachments and electrically isolated from all other components. Pre-loads are applied to the winding pack through an insulating, G-11CR plate.
- c. Cladding. The cladding is electrically connected to the chill plates and electrically isolated from all other components.
- d. Chill plates. The chill plates are electrically connected to the cladding and coolant tubes and electrically isolated from all other components.
- e. Coolant tube. Each coolant tube shall have an insulating break at the supply and return ends as shown in the loop labeled B in Figure 3-3. For those loops which span the poloidal break in the winding form, an additional insulating break is required at the location of the poloidal break as shown in the loop labeled A in Figure 3-3. Each electrically isolated coolant tube shall be electrically connected to the winding form through a high resistance ground that can be lifted to test the electrical isolation. All insulating breaks and high resistance grounds shall be located outside the winding form in a region accessible for maintenance.
- f. Co-wound diagnostic loops. The co-wound diagnostic loops are electrically isolated from all other components by shrink tubing. In addition, all diagnostics and instrumentation leads shall be isolated via optical and/or magnetic (isolation transformer) means prior to exiting the cryostat. The isolation shall be rated to withstand a one minute AC hipot test at 20 kV AC rms.

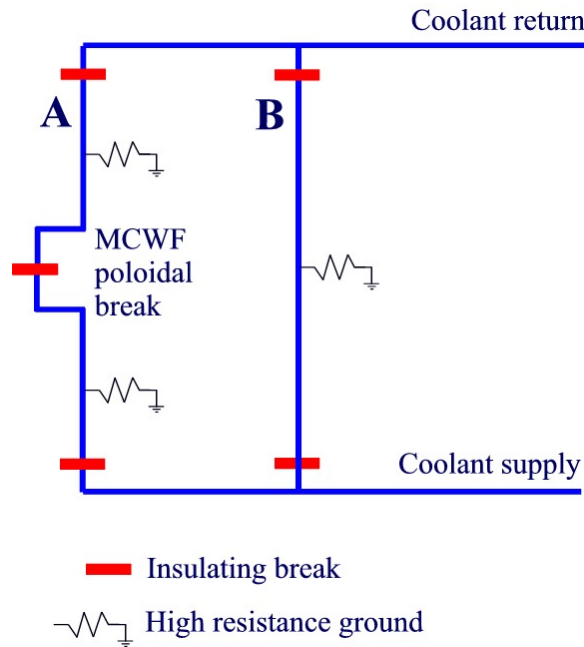

Figure 3-3 Electrical isolation and grounding of coolant loops

3.2.1.8.4 Electrical Resistance

The electrical resistance of the modular coil assembly shall be  $9.7 \pm 0.1$ -milliohm at room temperature and  $1.4 \pm 0.1$ -milliohm at 80K.

### **3.2.2 Physical Characteristics**

#### **3.2.2.1 Winding Form**

The product specification, NCSX-CSPEC-141-03, and its associated drawings defines the winding form assembly and requirements for its fabrication.

#### **3.2.2.2 Attachments**

Threaded studs and other attachments are welded to the winding form in order to facilitate winding operations. Some attachments are to be removed after winding in order prevent interference during field period assembly. Details and requirements are defined on the attachments and post-VPI assembly drawings.

#### **3.2.2.3 Winding Packs**

The winding pack assemblies, designated "Side-A" and "Side-B", are composed of conductor and ground insulation surrounded by an assembly of cladding and chill plates for cooling. The winding pack assembly shall slip relative to the winding form and not be permanently bonded to it. Further requirements are as follows:

##### **3.2.2.3.1 Cladding**

The cladding is a segmented layer of copper that lies between the winding pack and the winding form. All cladding parts shall be free of burrs and sharp edges that might damage the conductor, and all surfaces shall be roughened to promote bonding during the vacuum-pressure impregnation process. The cladding shall not be permanently bonded to the winding form.

##### **3.2.2.3.2 Chill Plates and Coolant Tubes**

The chill plates are a segmented layer of copper that covers the outer surfaces of the winding pack. All chill plates shall be free of burrs and sharp edges that might damage the conductor, and all surfaces shall be roughened to promote bonding during the vacuum-pressure impregnation process. Tubes are attached to the chill plates by soldering to form ten closed cooling loops per coil assembly.

##### **3.2.2.3.3 Conductor**

The product specification, NCSX-CSPEC-142-03, defines the physical requirements for the conductor and turn insulation. Supplemental turn insulation is required where the conductor penetrates the ground insulation at the leads. The supplemental insulation shall be composed of two half-lapped layers of 1-in wide x 0.007-in S2 glass and 0.75-in wide x 0.0065-in adhesive Kapton tape, for a total thickness of 0.041-in.

##### **3.2.2.3.4 Ground Insulation**

The ground insulation is composed of S2 glass and adhesive Kapton. The total thickness of 0.0445-in is composed of three layers: 1) a butt-lapped layer of 0.007-in S2 glass, 2) a half-lapped layer consisting of 2-in wide x 0.007-in S2 glass and 1.5-in wide x 0.0065-in adhesive Kapton tape, and 3) a butt-lapped layer of the same composite.

##### **3.2.2.3.5 Lead Blocks**

As shown on the referenced assembly drawings, the conductor lead blocks shall be pre-assembled to the winding form in order to align the starting lead blocks. All components shall be free of burrs and sharp

edges that might damage the conductor, and all surfaces shall be roughened to promote bonding during the vacuum-pressure impregnation process. Verify by visual and dimensional inspection.

#### **3.2.2.3.6 Terminal Assembly**

The terminal assembly includes the crossover jumpers and terminal lugs, as defined in the referenced drawings. All electrical contact surfaces shall be clean, and all bolted connections shall be torqued to specified values. All demountable electrical connections shall be accessible for maintenance and have provisions which ensure adequate contact pressure over time, i.e. under repeated thermal and mechanical loading.

#### **3.2.2.3.7 Clamps**

The clamps are defined by subassembly drawings and feature adjustable, spring loaded pads that provide a preload of ~125 lbs to the top and side of each winding pack. Verify installation, including location per the assembly drawings, by inspection.

#### **3.2.2.3.8 Co-wound Diagnostic Loops**

Diagnostic flux loops, composed of 0.032-in diameter mineral insulated wire, are located between the chill plates and VPI bag mold near the plasma facing surface of each winding pack. Supplemental insulation composed of shrink tubing shall be provided where the wire enters/exits the mold. A length of wire, approx 20-ft, shall be left outside the VPI envelope for routing to a junction box on the vacuum vessel. The location of the installed loops shall be measured prior to vacuum pressure impregnation.

#### **3.2.2.3.9 Instrumentation**

Each modular coil assembly shall be equipped with thermocouples on the winding form and voltage taps at the leads. Each assembly shall be instrumented with RTDs and strain gages as shown on the referenced drawings.

#### **3.2.2.3.10 Bag Mold Assembly**

The bag mold is composed of two layers of half-lapped, self-fusing gray silicone tape and painted with 2-part RTV-11 (white). The bag mold is sealed to the winding form using 0.25-in diameter copper tubing, which is to be removed after fabrication. A structural shell, composed of glass-epoxy paste that is cured at room temperature, shall be provided to restrain the bag mold during vacuum pressure impregnation (VPI). The shell is removed after VPI.

#### **3.2.2.4 Weight**

The maximum weight of a completed modular coil assembly shall not exceed 6500 lbs.

### **3.2.3 System Quality Factors**

#### **3.2.3.1 Reliability, Availability, and Maintainability**

#### **Background**

The overall objective is to provide a device with high operational availability, meaning that the number of plasma discharges achieved in a run period is a large percentage (greater than 75%) of the number planned after the initial shakedown and commissioning phases of the facility. Bottoms-up reliability predictions are difficult to perform and have large uncertainties for first-of-a-kind experimental devices such as NCSX. Therefore, quantitative RAM requirements on NCSX will be few. Rather, NCSX will rather rely on sound

engineering practice to assure high availability in NCSX, which has been the tried-and-true approach on similar scale fusion devices. Sound engineering practices include:

- Applying design principles that promote reliability (e.g., employing an adequate factor of safety on mechanical and electrical stresses, avoiding unnecessary complexity, using proven design approaches and well characterized materials, etc.)
- Optimizing designs for reliability and maintainability through systematic evaluation of design options,
- Performing failure modes, effects and criticality analysis (FMECAs) for RAM design improvement and verification, and
- Employing peer reviews as a mechanism to enhance the design process.

The NCSX RAM Plan defines the processes that will be used by the Project to achieve a device with high availability.

### **Requirements**

- a. The Assembly shall incorporate reliability and maintainability features in the design that are consistent with achieving a very high (greater than 99%) operational availability for each Assembly.
- b. Provisions for recovery shall be made for every credible failure mode in the Assembly.
- c. Provisions for lifting, e.g. lifting eyes, other sling attachment provisions, or equivalent provisions, shall be made in the design of the Assembly.

[Ref. SRD Section 3.2.3.1 Reliability, Availability, and Maintainability]

### **3.2.3.2 Design Life**

- a. The Assembly shall have a design life of >10 years when operated per the reference scenarios in Section 3.2.1.6.
- b. The Assembly shall be designed for the following maximum number of pulses when operated per the reference scenarios defined in Section 3.2.1.6 and based on the factors for fatigue life specified in the NCSX Structural and Cryogenic Design Criteria Document:
  - 100 per day;
  - 13,000 per year; and
  - 130,000 lifetime.

[Ref. SRD Section 3.2.3.2 Design Life]

### **3.2.4 Transportability**

The Assembly shall be transportable via overhead crane and forklift as required for testing in the Coil Test Facility (CTF) and for assembling into field periods in the Tokamak Fusion Test Reactor (TFTR) Test Cell.

### **3.2.5 Interface Requirements**

#### **3.2.5.1 Vacuum Vessel System (WBS 12) Interface Requirements**

#### **Background**

The vacuum vessel is physically supported from the modular coil shell for vertical (gravity and net electromagnetic loads) and lateral loads. The vacuum vessel is thermally insulated to reduce heat leakage from the vacuum vessel to the modular coils. The vacuum vessel port extensions penetrate the modular

coil shell. During field period assembly, the modular coils must be able to be assembled over the vacuum vessel.

#### Requirements

The modular coil assembly shall provide sufficient interior clearance to install over the vacuum vessel with port extensions and insulation. Minimum clearance is defined by post-VPI modular coil assembly drawings.

### **3.2.5.2 Conventional Coils (WBS 13) Interface Requirements**

#### Background

The TF, PF, and trim coils are attached to the Coil Support Structures, which are in turn attached to the Modular Coils. The conventional coils introduce electromagnetic loads on the modular coils and vice versa. During field period assembly, the TF coils must be able to be assembled over the modular coils.

#### Requirements

The modular coil assembly shall provide sufficient exterior clearance to be installed inside the TF coil subassembly. Minimum clearance is defined by post-VPI modular coil assembly drawings.

### **3.2.5.3 Coil Support Structures (WBS 15) Interface Requirements**

#### Background

The support structure is composed of structural plates above and below the modular coils. The upper plate supports the gravity and net electromagnetic loads from the upper PF ring coils, upper external trim coils, central solenoid assembly, and cryostat. The upper plate also provides out-of-plane support for the TF coils. These loads are transmitted through the modular coil shell to the lower plate along with gravity loads from the modular coils, vacuum vessel, and in-vessel components. Gravity loads from the stellarator core are transmitted through the lower plate to the Base Support Structure.

#### Requirements

The modular coil assembly shall interface with the support structure through the winding form shelf feature at R=39- and 79-inch locations.

### **3.2.5.4 Liquid Nitrogen Distribution System (WBS 161)**

#### Background

Liquid nitrogen for coil cooling is supplied from the Cryogenic Systems (WBS 62) to the LN2 Distribution System (WBS 161), which in turn supplies the liquid nitrogen to the individual modular coils.

#### Requirements

The modular coil assembly shall interface with LN2 distribution through connections on the outside of the winding form at the top, bottom, and outboard midplane locations.

### **3.2.5.5 Electrical Power Systems (WBS 4)**

#### Background

The current and voltage required to drive the modular coils is supplied from the Electrical Power Systems (WBS 4) to the Electrical Leads (WBS 162), which in turn supplies the direct current (DC) power to the individual modular coils. Electrical Power Systems (WBS 4) provide coil protection via parameters measured in the power supply circuitry based on parameters provided by Coil Protection System (WBS 163) activities. Electrical Power Systems (WBS 4) also provides coil protection via permissives and trip signals provided by Central I&C (WBS 5) in response to the output from sensors included in the local I&C

within the Modular Coil System (WBS 14). Electrical Power Systems (WBS 4) are responsible for providing single point grounds for the modular coil winding forms.

#### Requirements

The modular coil assembly shall interface with the Electrical Leads (WBS 162) near the outboard midplane. Connections to the Electrical Power Systems (WBS 4) shall be outside the cryostat at room temperature.

### **3.2.5.6 Central I&C (WBS 5)**

#### Background

Central I&C (WBS 5) is responsible for taking the output from the sensors (e.g. strain gauges, resistance temperature detectors, and thermocouples) provided in the local I&C in the Modular Coil System (WBS 14), processing those signals, displaying and storing the data, and providing permissives and trip signals for coil protection to Electrical Power Systems (WBS 4) in accordance with the coil protection logic and parameters specified by the Coil Protection Systems (WBS 163).

#### Requirement

The design of the Assembly shall meet the physical interface requirements as defined by the referenced drawings.

### **3.3 Design and Construction**

#### **3.3.1 Materials, Processes, and Parts**

##### **3.3.1.1 Production Drawings**

The Assembly shall be fabricated in accordance with the models and drawings listed in Section 5.1.

##### **3.3.1.2 Magnetic Permeability**

The Assembly shall have a relative magnetic permeability less than 1.02 unless otherwise authorized by the Project. [Ref. SRD Section 3.3.1.1 Magnetic Permeability]

##### **3.3.1.3 Corrosion Prevention and Control**

Materials, processes, and protective surface treatments or finishes shall be provided to ensure that equipment capability during its service life is not degraded due to corrosion. Where possible, contact between dissimilar metals shall be avoided. [Ref. SRD Section 3.3.1.2 Corrosion Prevention and Control]

##### **3.3.1.4 Flammable Materials**

The use of flammable materials shall be minimized. [Ref. SRD Section 3.3.6.3 Flammability]

##### **3.3.1.5 Metrology**

The Assembly shall provide features (e.g., fiducial markers) as required to facilitate accurately measuring and locating components relative to the magnetic field for the life of the machine. [Ref. SRD Section 3.3.1.3 Metrology]



### 3.3.2 Labels

#### Background

Equipment and any parts of that equipment to be used by personnel shall be identified with appropriate labels. Labels shall indicate clearly and concisely the function and purpose of the item being labeled. Hierarchical labeling shall be used to facilitate component location on control panels. The terminology used for equipment, procedures, and training materials shall be the same for each case. Label design shall be consistent to promote simplicity and avoid clutter. The use of abbreviations and acronyms shall be minimized. Permanent labels shall be attached to the specific component or equipment in such a manner that environmental conditions or usage by personnel will not remove or destroy the label. Temporary labels shall be used only when necessary and shall not obscure other information or equipment. If a temporary label is to designate a device that is out of service, the label shall be applied so that it prevents the use of that device. Labeling shall be legible and conform to human visual capabilities and limitations in regard to physical characteristics. [Ref. SRD Section 3.3.3.1 Labels]

#### Requirement

- a. The Assembly shall have a permanent label with the following minimum information – the name of the item and the part and serial number of the item, e.g. NCSX Modular Coil Type C Assembly, P/N SE140-103, S/N 1. The label shall be located to be most easily viewed by maintenance personnel.
- b. Component parts of the Assembly shall be appropriately labeled.

### 3.3.3 Workmanship

During Assembly fabrication and finishing, particular attention shall be given to freedom from blemishes, defects, burrs, and sharp edges; accuracy of dimensioning radii of weld fillets; making of parts; thoroughness of cleaning; quality of brazing, welding, riveting, painting, and wiring; alignment of parts; and tightness and torquing of fasteners. [Ref. SRD Section 3.3.4 Workmanship]

### 3.3.4 Interchangeability

Design tolerances shall permit Assemblies of the same part number to be used as replacement parts without degrading the specified performance of the parent item. [Ref. SRD Section 3.3.5 Interchangeability]

## 4 QUALITY ASSURANCE PROVISIONS

### 4.1 General

The Assembly will be fabricated at PPPL in the Coil Manufacturing Facility (CMF) located in the TFTR Test Cell. Acceptance testing of subsequent articles will be performed in the CMF at the conclusion of Assembly fabrication. The design of the Assembly will be qualified by testing the first article at high current in the Coil Test Facility (CTF) to the extent practical.

The Project has sole responsibility for inspections and tests. The Manager of the CMF has responsibility for those inspections and tests performed in the CMF. The Manager of the CTF has responsibility for inspections and tests performed in the CTF.

### 4.2 Verification Methods

Verification of qualification shall be by analysis, demonstration, inspection, or test. Definition of analysis, demonstration, inspection, and test is as follows:

Analysis: Verification of conformance with required characteristics by calculation or simulation, including computer modeling based on established material or component characteristics.

Inspection: Verification of conformance by measuring, examining, testing, and gauging one or more characteristics of a product or service and comparing the results with specified requirements.

Test: Verification by physically exercising a component or system under appropriate loads or simulated operating conditions, including measurement and analysis of performance data.

### **4.3 Quality Conformance**

This section establishes the specific methods for verification of requirements in Section 3.

#### **4.3.1 Verification of Design Verification Requirement**

Verification of conformance with the design verification requirement (Section 3.2.1.1) shall be by inspection of the design to be accomplished during Final Design of the Assembly.

##### **4.3.1.1 Verification of Coil Cool-down and Warm-up Timelines**

Verification of conformance with the timeline requirements for coil cool-down (Section 3.2.1.2) and warm-up (Section 3.2.1.3) shall be by qualification testing in the Coil Test Facility for the first article.

##### **4.3.1.2 Verification of Pre-Pulse Temperature**

Verification of conformance with the pre-pulse temperature requirement in Section 3.2.1.4 shall be [1] by analysis performed during Final Design and [2] by qualification testing in the Coil Test Facility for the first article.

##### **4.3.1.3 Verification of Field Error Requirements**

###### **4.3.1.3.1 Verification of the Poloidal Electrical Breaks**

Verification of conformance with the poloidal electrical break resistance requirement in Section 3.2.1.5.1 shall be by [1] acceptance testing each completed modular coil winding form at the Supplier and [2] acceptance testing of each completed Assembly in the Coil Manufacturing Facility.

###### **4.3.1.3.2 Verification of Winding Tolerance**

- a. Verification of conformance with the winding tolerance requirement in Section 3.2.1.5.2 shall be by done by in-process inspection upon completion of coil winding. The location of the local current centroid will be inferred from measurements of the winding form surface prior to winding and measurements of the conductor surface upon completion of winding. The winding clamps will be used to move the location of the local current centroid to within the winding tolerance requirement. Fiberglass straps will be used to stabilize the winding pack. The torque values required to set the winding clamps in the proper position shall be recorded and used to re-set the winding clamps each time they are removed. This procedure shall be used to maintain the location of the local current centroid within the winding tolerance requirement for the remainder of Assembly fabrication.
- b. During acceptance testing of the completed Assembly, magnetic measurements shall be taken to locate the local current centroid and verify conformance with the winding tolerance requirement in Section 3.2.1.5.2.

###### **4.3.1.4 Verification of Reference Scenario Requirements**

- a. Verification of conformance with the reference scenario requirements in Section 3.2.1.6 shall be by analysis during Final Design.

- b. During qualification testing in the Coil Test Facility on the first article, key performance parameters (stresses, deflections, temperatures, pressures, etc.) shall be measured and compared to calculated values to assure that the Assembly is performing consistent with expectations, i.e. analysis.

#### **4.3.1.5 Verification of Pulse Repetition Rate**

Verification of conformance with the pulse repetition rate requirement in Section 3.2.1.7 shall be [1] by analysis during Final Design and [2] by qualification testing of the first article in the Coil Test Facility.

#### **4.3.1.6 Verification of Electrical Requirements**

##### **4.3.1.6.1 Verification of Electrical Isolation of the Conductor**

Verification of conformance with the electrical isolation requirements in Section 3.2.1.11.1 shall be accomplished as follows.

- a. **Verification of Design Voltage Standoff.** The insulation system shall be qualified to the design voltage standoff (15kV) by testing during Final Design.
- b. **Verification of Manufacturing Test Voltage.** Each Assembly shall be meggar tested at room temperature to the manufacturing test voltage (7.5kV) during acceptance testing in the Coil Manufacturing Facility. In addition, the first article shall be meggar tested at cryogenic temperature to the manufacturing test voltage (7.5kV) during qualification testing in the Coil Test Facility.

##### **4.3.1.6.2 Verification of Turn-to-turn Voltage Standoff**

Verification of conformance with the turn-to-turn voltage standoff requirement in Section 3.2.1.8.2 shall be performed by testing the insulation system during Final Design.

##### **4.3.1.6.3 Verification of Electrical Isolation and Grounding of Other Components**

Verification of conformance with electrical isolation and grounding requirements in Section 3.2.1.8.3 shall be by [1] in-process tests during Assembly manufacture and [2] acceptance testing of the completed Assembly. In addition, electrical isolation features shall be qualified during Final Design. Specifically, the design of the electrical breaks in the coolant tubes shall be qualified by testing under representative conditions.

##### **4.3.1.6.4 Verification of Electrical Resistance**

Verification of conformance with the Electrical Resistance requirements in Section 3.2.1.8.4 shall be accomplished as follows:

- a. The electrical resistance of each Assembly (terminal-to-terminal) shall be measured at room temperature (20°C) during acceptance testing in the Coil Manufacturing Facility.
- b. The electrical resistance of the first article (terminal-to-terminal) will be measured at cryogenic temperature (80K) during qualification testing in the Coil Test Facility.

#### **4.3.2 Verification of Physical Characteristics**

##### **4.3.2.1 Weight**

Verification of conformance with the weight requirements in Section 3.2.2.4 shall be accomplished during acceptance testing of the completed Assembly in the Coil Manufacturing Facility.

**4.3.3 Verification of System Quality Factors****4.3.3.1 Reliability, Availability, and Maintainability**

Verification of conformance with the reliability, availability, and maintainability requirements in Section 3.2.3.1 shall be accomplished by design inspection and analysis in Final Design.

**4.3.3.2 Design Life**

Verification of conformance with the design life requirements in Section 3.2.3.2 shall be accomplished by analysis and R&D testing accomplished prior to the completion of Final Design.

**4.3.3.3 Transportability**

Verification of conformance with the transportability requirements in Section 3.2.4 shall be accomplished by design inspection prior to the completion of Final Design.

**5 APPENDICES**

**5.1 Assembly Models and Drawings**

**5.1.1 Modular Coil Assembly Type C**

DRAWING NO.	REV	REL DATE	MODEL NO.	PART NO.	QTY	DESCRIPTION	MATERIAL / SPECIFICATION	WEIGHT (LBS)	FIND NO.	NEXT ASM
SE141-103	2	8/5/05	SE141-103	-1	AR	MOD COIL WINDING FORM ASM TYPE-C	---	5092	1	SE140-103
SE141-078	1	9/23/04	SE141-078	-1	AR	POL BREAK SHIM ASM TYPE-C	---	129	1	SE141-103
SE141-116	6	8/5/05	SE141-116	-1	AR	PRODUCTION WINDING FORM TYPE-C	SS, CSPEC-141-03	---	1	SE141-103
DS141-036	1	8/5/05	SE141-036	-1	AR	STUD, 1.375-6UNC-2A X 9.5 LG	A286	---	1	SE141-103
DS141-060	0	7/20/04	SE141-060	-1	AR	NUT, 12PT HEX 1.375-6UNC-2B	A286	---	1	SE141-103
DS141-079	0	7/20/04	SE141-079	-1	AR	WASHER, 2.75 OD X 1.86 ID X 0.5 THK	A286	---	1	SE141-103
SE141-123	1	WIP	SE141-123	-1	AR	TYPE-C WINDING FORM MODS ASM	---	5616	1	SE140-103
SE780-011	0	5/12/05	SE141-127	-1	AR	METROLOGY TARGET	SS, UNS S31600	---	1	SE141-123
SE141-137	0	10/5/05	SE141-137	-1	AR	BEARING PLATE	SS, UNS S31600	---	1	SE141-123
SE141-138	0	10/5/05	SE141-138	-1	AR	BEARING PLATE	SS, UNS S31600	---	1	SE141-123
SE142C-280	0	10/14/05	SE142C-280	-1	AR	TYPE-C LEADS ALIGNMENT FIXTURE	---	TBD	1	SE140-103
SE142C-281	0	10/14/05	SE142C-281	-1	AR	LOWER MOUNTING PLATE	AL 6061 T6	---	1	SE142C-280
SE142C-282	0	10/14/05	SE142C-282	-1	AR	LEAD SLOT POSTS	BRASS UNS C36000	---	1	SE142C-280
SE142C-284	0	10/14/05	SE142C-284	-1	AR	SIDE BAR	AL 6061 T6	---	1	SE142C-280
SE142C-285	0	10/14/05	SE142C-285	-1	AR	BUSHING, .61 OD x .41 ID x 5 LG	BRASS UNS C36000	---	1	SE142C-280
SE142C-286	0	10/14/05	SE142C-286	-1	AR	UPPER MOUNTING PLATE	SS, UNS S31600	---	1	SE142C-280
SE142C-287	0	10/14/05	SE142C-287	-1	AR	CENTERING NUT	SS, UNS S31600	---	1	SE142C-280
SE142C-080	0	WIP	SE142C-080	-1	AR	TYPE-C LEAD BLOCKS PRE-FIT ASM	---	TBD	1	SE140-103
SE142C-134	1	8/12/05	SE142C-134	-1	AR	TYPE-C COIL SIDE-A LOWER LEAD BLOCK	STL - ABS / POLY	---	1	SE142C-080
SE142C-134	2	10/4/05	SE142C-134	-1	AR	TYPE-C COIL SIDE-A LOWER LEAD BLOCK	NEMA GRADE G-11CR	---	1	SE142C-080
SE142C-135	0	8/12/05	SE142C-135	-1	AR	TYPE-C COIL SIDE-B LOWER LEAD BLOCK	STL - ABS / POLY	---	1	SE142C-080
SE142C-135	1	10/4/05	SE142C-135	-1	AR	TYPE-C COIL SIDE-B LOWER LEAD BLOCK	NEMA GRADE G-11CR	---	1	SE142C-080
SE142C-136	0	7/8/05	SE142C-136	-1	AR	TYPE-C COIL SIDE-A UPPER LEAD BLOCK	NEMA GRADE G-11CR	---	1	SE142C-080
SE142C-136	0	7/8/05	SE142C-136	-1	AR	TYPE-C COIL SIDE-A UPPER LEAD BLOCK	STL - ABS / POLY	---	1	SE142C-080
SE142C-137	0	7/8/05	SE142C-137	-1	AR	TYPE-C COIL SIDE-B UPPER LEAD BLOCK	NEMA GRADE G-11CR	---	1	SE142C-080
SE142C-137	0	7/8/05	SE142C-137	-1	AR	TYPE-C COIL SIDE-B UPPER LEAD BLOCK	STL - ABS / POLY	---	1	SE142C-080
SE142C-184	0	7/20/05	SE142C-184	-1	AR	TYPE-C COIL LEADS ENCLOSURE TOP PLATE	NEMA GRADE G-11CR	---	1	SE142C-080
SE142C-184	0	7/20/05	SE142C-184	-1	AR	TYPE-C COIL LEADS ENCLOSURE TOP PLATE	STL - ABS / POLY	---	1	SE142C-080
SE142C-226	0	WIP	SE142C-226	-1	AR	FILLER STRIP	COPPER, ANNEALED UNS C10100, C10200	---	1	SE142C-080
SE142C-183	0	WIP	SE142C-183	-1	AR	TYPE-C COIL LEADS AREA CHILL PLATE	COPPER, ANNEALED UNS C10100, C10200	---	1	SE142C-080
SE142C-220	0	7/26/05	SE142C-220	-1	AR	TYPE-C COIL SIDE-A LEADS SIDE PLATE	NEMA GRADE G-11CR	---	1	SE142C-080
SE142C-221	0	7/26/05	SE142C-221	-1	AR	TYPE-C COIL SIDE-B LEADS SIDE PLATE	NEMA GRADE G-11CR	---	1	SE142C-080
SE142C-050	0	WIP	SE142C-050	-1	AR	LEADS TERMINAL ASSEMBLY	---	TBD	1	SE140-103
SE142C-211	0	9/16/05	SE142C-211	-1	AR	INS SHEET, 3.47 X 12.38 X .063 THK	NEMA GRADE G-11CR	---	1	SE142C-050
SE142C-047	0	WIP	SE142C-047	-1	AR	JUMPERS BASE BLOCK	---	2.5	1	SE142C-050
SE142C-049	0	9/16/05	SE142C-049	-1	AR	INS SHEET, 1.5 X 8 X 0.13 THK	NEMA GRADE G-11CR	---	1	SE142C-050
SE142C-051	0	8/12/05	SE142C-051	-1	AR	TERMINAL JUMPER #1	OFHC COPPER UNS C10100/102	---	1	SE142C-050
SE142C-051	0	8/12/05	SE142C-051	-1	AR	TERMINAL JUMPER #1	STL - ABS / POLY	---	1	SE142C-050
SE142C-052	0	8/12/05	SE142C-052	-1	AR	TERMINAL JUMPER #2	OFHC COPPER UNS C10100/102	---	1	SE142C-050
SE142C-052	0	8/12/05	SE142C-052	-1	AR	TERMINAL JUMPER #2	STL - ABS / POLY	---	1	SE142C-050
SE142C-053	0	8/12/05	SE142C-053	-1	AR	TERMINAL JUMPER #3	OFHC COPPER UNS C10100/102	---	1	SE142C-050
SE142C-053	0	8/12/05	SE142C-053	-1	AR	TERMINAL JUMPER #3	STL - ABS / POLY	---	1	SE142C-050
SE142C-054	0	8/12/05	SE142C-054	-1	AR	TERMINAL JUMPER #4	OFHC COPPER UNS C10100/102	---	1	SE142C-050
SE142C-054	0	8/12/05	SE142C-054	-1	AR	TERMINAL JUMPER #4	STL - ABS / POLY	---	1	SE142C-050
SE142C-055	0	WIP	SE142C-055	-1	AR	TERMINAL LUG, SHORT	OFHC COPPER UNS C10100/102	---	1	SE142C-050
SE142C-056	0	WIP	SE142C-056	-1	AR	TERMINAL LUG, LONG	OFHC COPPER UNS C10100/102	---	1	SE142C-050
SE142C-212	0	9/16/05	SE142C-212	-1	AR	INS SHEET, 3.34 X 5.75 X 0.13 THK	NEMA GRADE G-11CR	---	1	SE142C-050
SE142C-263	0	WIP	SE142C-263	-1	AR	TERMINAL SPLICE PLATE	OFHC COPPER UNS C10100/102	---	1	SE142C-050
SE142C-059	1	7/25/05	SE142C-059	-1	AR	CABLE CONNECTOR	AG BEARING COPPER, UNS C10300/105/107	---	1	SE142C-050
SE142C-251	0	WIP	SE142C-251	-1	AR	TYPE-C COIL SIDE-A ASSEMBLY	---	TBD	1	SE140-103
SE142C-382	0	WIP	NONE	-1	AR	TYPE-C COIL SIDE-A UPPER CLADDING ASM	---	TBD	1	SE142C-251
SE142C-382* (19 GEN)	0	WIP	SE142C-382* (19 GEN)	-2	191	CLADDING PARTS	COPPER, ANNEALED UNS C10100, C10200	---	2	
SE142C-384	0	WIP	NONE	-1	AR	TYPE-C COIL SIDE-A LOWER CLADDING ASM	---	TBD	1	SE142C-251
SE142C-384* (21 GEN)	0	WIP	SE142C-384* (21 GEN)	-2	191	CLADDING PARTS	COPPER, ANNEALED UNS C10100, C10200	---	2	
SE142C-386	0	WIP	NONE	-1	AR	TYPE-C COIL SIDE-A UPPER CHILL PLATE ASM	---	TBD	1	SE142C-251
SE142C-386* (21 GEN)	0	WIP	SE142C-386* (21 GEN)	-2	191	CHILL PLATE PARTS	COPPER, ANNEALED UNS C10100, C10200	---	2	
SE142C-388	0	WIP	NONE	-1	AR	TYPE-C COIL SIDE-A LOWER CHILL PLATE ASM	---	TBD	1	SE142C-251
SE142C-388* (21 GEN)	0	WIP	SE142C-388* (21 GEN)	-2	191	CHILL PLATE PARTS	COPPER, ANNEALED UNS C10100, C10200	---	2	
SE142C-241	0	WIP	SE142C-241	-1	AR	TYPE-C COIL SIDE-B ASSEMBLY	---	TBD	1	SE140-103
SE142C-482	0	WIP	NONE	-1	AR	TYPE-C COIL SIDE-B UPPER CLADDING ASM	---	TBD	1	SE142C-241
SE142C-482* (21 GEN)	0	WIP	SE142C-482* (21 GEN)	-2	191	CLADDING PARTS	COPPER, ANNEALED UNS C10100, C10200	---	2	
SE142C-484	0	WIP	NONE	-1	AR	TYPE-C COIL SIDE-B LOWER CLADDING ASM	---	TBD	1	SE142C-241
SE142C-484* (21 GEN)	0	WIP	SE142C-484* (21 GEN)	-2	191	CLADDING PARTS	COPPER, ANNEALED UNS C10100, C10200	---	2	
SE142C-486	0	WIP	NONE	-1	AR	TYPE-C COIL SIDE-B UPPER CHILL PLATE ASM	---	TBD	1	SE142C-241
SE142C-486* (21 GEN)	0	WIP	SE142C-486* (21 GEN)	-2	191	CHILL PLATE PARTS	COPPER, ANNEALED UNS C10100, C10200	---	2	
SE142C-488	0	WIP	NONE	-1	AR	TYPE-C COIL SIDE-B LOWER CHILL PLATE ASM	---	TBD	1	SE142C-241
SE142C-488* (21 GEN)	0	WIP	SE142C-488* (21 GEN)	-2	191	CHILL PLATE PARTS	COPPER, ANNEALED UNS C10100, C10200	---	2	
SE142C-291	0	WIP	SE142C-291	-1	AR	TYPE-C VPI ASSEMBLY	---	TBD	2	SE140-103
SE142C-291	0	WIP	TBD	-2	AR	PAD	NEMA GRADE G-11CR	---	2	SE140-103
SE142C-291	0	WIP	TBD	-3	AR	BAG MOLD	VULCANIZING TAPE CHOPPED GLASS	---	3	SE140-103
SE142C-291	0	WIP	TBD	-4	AR	SEAL TUBE	COPPER	---	4	SE140-103
SE142C-270	0	WIP	SE142C-270	-1	AR	CLAMP ASSEMBLY	---	TBD	1	SE140-103
SE142C-271	0	WIP	SE142C-271	-1	AR	CLAMP BAR	SS, UNS S31600	---	1	SE142C-270
SE142C-272	0	WIP	SE142C-272	-1	AR	BUSHING, SPACER	SS, UNS S31600	---	1	SE142C-270
SE142C-273	0	WIP	SE142C-273	-1	AR	WASHER, SPHERICAL CONVEX	SS, UNS S31600	---	1	SE142C-270
SE142C-274	0	WIP	SE142C-274	-1	AR	WASHER, SPHERICAL CONCAVE	SS, UNS S31600	---	1	SE142C-270
SE142C-275	0	WIP	SE142C-275	-1	AR	KEEPER	SS, UNS S31600	---	1	SE142C-270
SE142C-311	0	WIP	SE142C-311	-1	AR	MAG WIRE LAYOUT	---	---	1	SE140-103
SE142C-321	0	WIP	SE142C-321	-1	AR	POST VPI MODS	---	---	1	SE140-103
SE142C-331	0	WIP	SE142C-331	-1	AR	I&C DRAWING, PREP FOR COLD TEST	---	---	1	SE140-103
SE142C-341	0	WIP	SE142C-341	-1	AR	DIAGNOSTICS	---	---	1	SE140-103
SE142C-351	0	WIP	SE142C-351	-1	AR	CURRENT FEED INSULATION COVER	---	---	1	SE140-103
SE142C-361	0	WIP	SE142C-361	-1	AR	BUSHING INSTALLATION	---	---	1	SE140-103