

NCSX

Modular Coil Winding Dimensional Control Plan

NCSX-PLAN-MCWDC-00

November 1, 2005

Author: _____
Brent Stratton- Dimensional Control Coordinator

Reviewed By: _____
Steve Raftopoulos- Metrology Engineer

Reviewed By: _____
Mike Zarnstorff- NCSX Project Physics Manager

Reviewed By: _____
Arthur Brooks- Technical Assurance Coordinator

Reviewed By: _____
James Chrzanowski- Modular Coil Facility Manager

Reviewed By: _____
Dave Williamson- WBS Manager for Modular Coils
(WBS14)

Reviewed By: _____
Brad Nelson- Project Engineer for Stellarator Systems
(WBS 1) Manager

Reviewed By: _____
Larry Dudek – Stellarator Core On-Site Fabrication RLM

Approved By: _____
Wayne Reiersen – NCSX Engineering Manager

Controlled Document
THIS IS AN UNCONTROLLED DOCUMENT ONCE PRINTED.
Check the NCSX Engineering Web prior to use to assure that this document is current.

**Modular Coil Winding Dimensional Control Plan
NCSX-PLAN-MCWDC-00**

RECORD OF CHANGE

Revision	Date	Description of Change
00	11/1/05	Initial release

TABLE OF CONTENTS

1	Introduction and Scope.....	1
1.1	Introduction	1
1.2	Scope	1
2	Overview and Assumptions	2
3	Coil Winding and Dimensional Control Steps.....	4
3.1	Casting Preparation Station Activities	4
3.2	Winding Station [Groundwrap & winding] Activities- Station 2 or 4	8
3.3	Winding Station [Post Groundwrap] Activities- Station 2 or 4	10
Appendix 1.....		11

List of Figures

Figure 2-1 Cross Section of Modular Coil.....	3
Figure 3-1 Locations of Measurement Monuments on Winding Form	4
Figure 3-2 Points for Measurement of Winding Form and Pack with Romer Arm	5
Figure 3-3 Clamp Numbering Scheme for Type C Coil.....	6
Figure 3-4 Fit to Measured Variation of Winding Pack Height on Side A of TRC Showing Correlation with In- and Out-of Plane Curvature and Torsion.....	7

Modular Coil Winding Dimensional Control Plan

NCSX-PLAN-MCWDC-00

1 Introduction and Scope

1.1 Introduction

This plan describes the steps that will be taken to ensure adequate dimensional control of the modular coils to be manufactured at the Princeton Plasma Physics Laboratory (PPPL) for the National Compact Stellarator Experiment (NCSX). Six of each of three types of modular coils will be manufactured. These coils are denoted types A, B, and C. The coils are fabricated by winding flexible copper rope conductor onto a precision machined winding form. Other components, such as copper cladding and chill plates, ground wrap, and the Vacuum Pressure Impregnation (VPI) bag mold are also installed during the fabrication process. The coil is then made into a rigid structure by injecting it with epoxy using the VPI process and curing the epoxy at high temperature. In order to minimize field errors in the NCSX plasma, the current centroid of each coil must be everywhere within ± 0.060 " of the design value in the completed NCSX device. In addition to the uncertainty in the current centroid due to the winding process, there will be uncertainties in assembling the coils into field periods and in assembling the field periods into the completed device. An uncertainty of ± 0.020 " in the position of the current centroid is assigned to each of these three sources. Thus, each coil must be fabricated in such a way that the current centroid is everywhere within ± 0.020 " of the design location. To ensure stellarator symmetry, it is also important that the positions of the current centroids of all the coils of each type are as similar to each other as possible.

1.2 Scope

This document describes the dimensional control steps that will be taken to ensure that the position of the current centroid of each modular coil is within ± 0.020 " of the design value and that the position is accurately known with respect to the measurement monuments that will be used to position the coils during machine assembly. It does not address the uncertainties mentioned above that arise during machine assembly. This document is not a coil fabrication procedure. It is meant to provide an overview of the dimensional control strategy for the winding of the modular coils and to provide input into the fabrication procedures.

1.2.1 Relevant Documents

This document along with the "NCSX Coil Manufacturing Facility Operations Plan" [NCSX-PLAN-CMFOP-01-00] and the "Modular Coil Manufacturing, Inspection, Test and Quality Assurance Plan" [NCSX-PLAN-MITQA-142-01] will govern the processes by which the modular coils will be fabricated.

Modular Coil Winding Dimensional Control Plan

NCSX-PLAN-MCWDC-00

1.2.2 Relevant Procedures

The coils will be fabricated according to the latest version of the following procedures and other documents referred to in these procedures:

- “Modular Coil Fabrication-Winding Form Preparation Activities” [D-NCSX-MCF-001]
- “Modular Coil Fabrication-Winding Station Activities” [D-NCSX-MCF-002]
- “Modular Coil Fabrication-VPI/Autoclave Activities” [D-NCSX-MCF-003]
- “Modular Coil Fabrication-Post VPI Preparation Activities” [D-NCSX-MCF-004]
- “Dimensional Control and Metrology for NCSX Modular Coils” [D-NCSX-MCF-005]

2 Overview and Assumptions

The dimensional control steps outlined in this document are the result of experience gained during the fabrication of the “Twisted Racetrack Coil” (TRC) prototype modular coil, and on the “straight tee” winding form during the period February-August 2005. The winding surfaces of the winding forms have a tee-shaped cross section, as shown in Figure 2-1. Each coil has two winding packs, one on each side of the central septum. Each winding pack is wound onto the winding form base on one side of the septum. The two sides of each coil are denoted “A” and “B”. During winding, the winding pack is held in place by side and top clamps. These clamps must be removed to add each layer of conductor and then replaced to hold the conductor in place. The winding packs are 4 conductors wide, with 10 turns for the type C coils and 11 turns for the type A and B coils.

Modular Coil Winding Dimensional Control Plan NCSX-PLAN-MCWDC-00

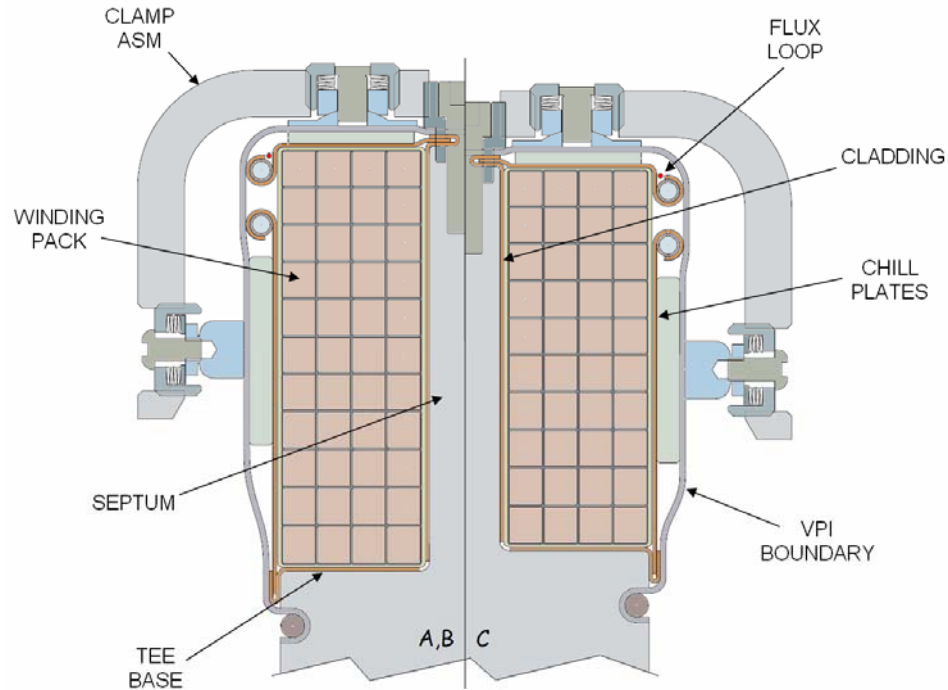

Figure 2-1 Cross Section of Modular Coil

The basic winding strategy is to wind “into the box” by setting the side clamps to predetermined positions before the start of winding. The side clamps will be returned to these positions after being removed to add each layer of conductor. The top clamp screws will be set to a specific torque value when they are replaced after a layer of conductor is added. This strategy was employed in winding side A of the TRC, and it replaces the original plan of winding one less turn for each coil type and using shims to control the height of each turn. The original plan was tried on side B of the TRC and was unsatisfactory because it was not possible to adequately control the position of each layer of conductor. The TRC experience showed that the compression required to fit the extra turn required by the “wind into the box” strategy is achievable. The side clamps will be set to positions calculated to achieve the desired height and width of the completed winding pack. When winding is complete, the height and width of the winding pack will be adjusted using the side and top clamps to place the current centroid of the coil within ± 0.020 ” of the design location. Note that this strategy controls the position of the current centroid by controlling the external dimensions of the winding pack. This assumes uniform compression of the winding pack during winding and adjustment. The validity of this assumption will be tested when the TRC winding pack is cut into sections and removed from the winding form.

Once the winding packs are complete and have been adjusted to put the current centroid in the desired location, they will be stabilized by binding them between the winding clamps with glass cloth strips. The purpose of these binding strips is to minimize changes in the height and width of the pack when the top and side clamps

Modular Coil Winding Dimensional Control Plan NCSX-PLAN-MCWDC-00

are temporarily removed a few at a time to complete the ground wrap and add the chill plates, cooling tubes, and bag mold.

The measurement tools to be used include the Romer measuring arm and gauge blocks.

3 Coil Winding and Dimensional Control Steps

This section outlines the dimensional control steps that will be taken through the coil manufacturing process. Only coil fabrication steps that are important to dimensional control are given in this outline. Note: measurement steps in italics will be performed on at least the first coil of each type. They may be eliminated for subsequent coils if the measurement results from the first coil are consistent with the expected stack up of components.

3.1 Casting Preparation Station Activities

- 3.1.1 Spot weld measurement monuments to inside surface of winding form near flanges, as shown in Figure 3-1. Six to eight monuments will be welded to each side of winding form in locations that can be accessed with the Romer arm mounted in one location. The monuments will be of the conical seat type.
- 3.1.2 Set up Romer arm and check its calibration against NIST-traceable standard.

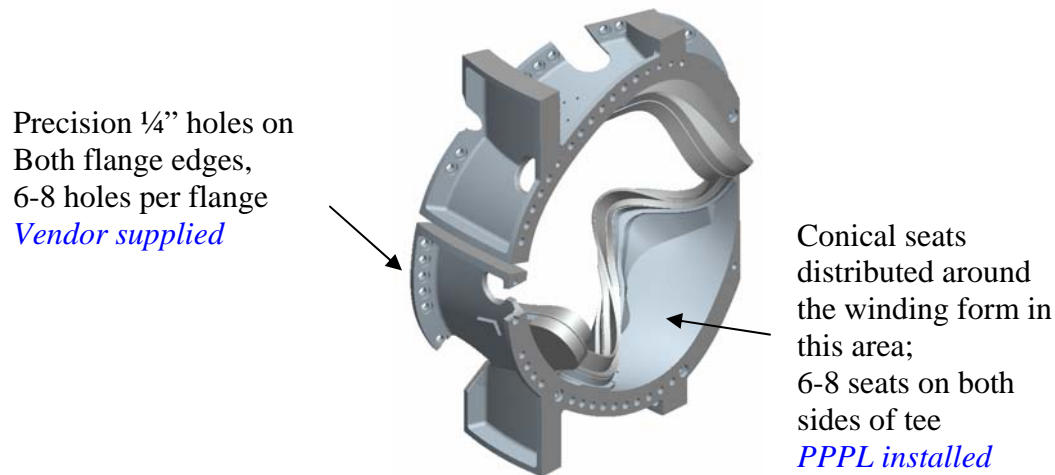

Figure 3-1 Locations of Measurement Monuments on Winding Form

- 3.1.3 Install Tooling balls into holes into holes on modular coil winding form flanges provided by winding form manufacturer. Using Romer arm, measure

**Modular Coil Winding Dimensional Control Plan
NCSX-PLAN-MCWDC-00**

the location of the tooling balls and perform a best-fit alignment to the coordinates provided by the manufacturer.

- 3.1.4 Measure the conical seat monuments and incorporate them into the CAD model.
- 3.1.5 Re-measure monuments.
- 3.1.6 Measure winding surfaces in the same pattern as will be used for measurements taken during coil winding. This is necessary to determine component stack up from measurements during winding. The measurements shall be made in the same pattern as was used on the TRC. There will be 12 measurement points in three groups of four on the base of the winding surface between each pair of clamps, as shown in Figure 3-2. There will be either 10 or 11 points on the septum at each of these three locations, depending on the type of coil (10 for type C and 11 for types A and B). A measurement fixture that can be installed at each clamp position will be used to define the measurement points. The clamp numbering scheme shown in Figure 3-3 will be used. Clamp number one is defined as being in the center of the lead penetration in the winding form. Sides A and B shall be uniquely defined for each coil type. Side A of the type C coil is shown in red in figure 3-3.

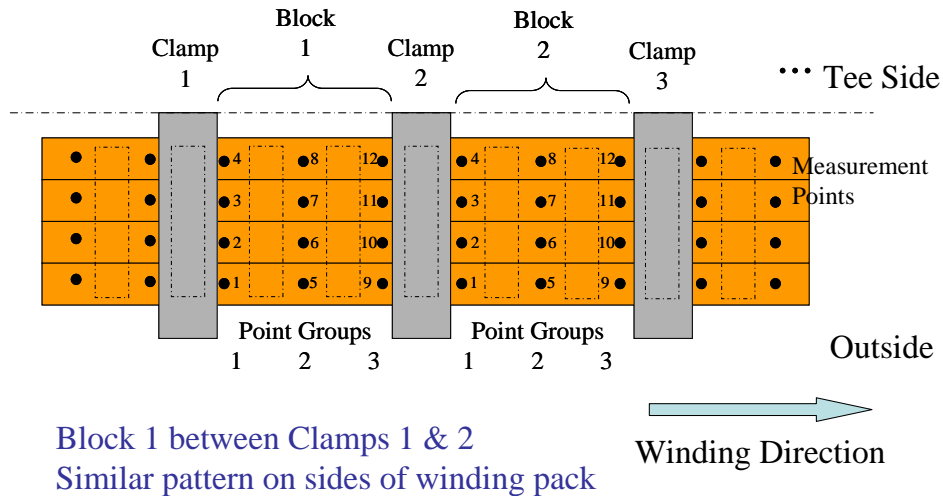
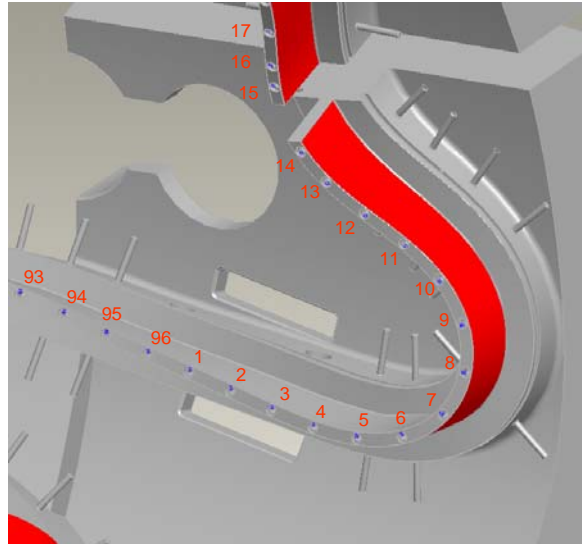

Figure 3-2 Points for Measurement of Winding Form and Pack with Romer Arm

**Modular Coil Winding Dimensional Control Plan
NCSX-PLAN-MCWDC-00**



**Figure 3-3 Clamp Numbering Scheme for Type C Coil
Red Denotes Side A of the coil**

- 3.1.7 Measure the flanges, bolt holes, and any other areas relevant to field period assembly.
- 3.1.8 Re-measure monuments.
- 3.1.9 Spot check measurements of winding form and monuments (steps 3.1.5-3.1.8) to verify that they are reproducible.
- 3.1.10 Calculate the side clamp positions using the expressions in Section 1 of M. Zarnstorff's memo "Determining Clamping Target Deviations" (reproduced in Appendix 1) and the measurements from step 3.1.6. Note that these expressions assume that the winding form septum surfaces are straight, perpendicular to the base, and in the desired orientation. More general expressions are needed if these conditions are not satisfied, e. g., if the septum is tilted or if the tee is rotated. To allow for variations in the pack width due to torsion and curvature, these predictions should be adjusted using the fit to the TRC side A layer 10 height measurements shown in Figure 3-4. An Excel spreadsheet to perform these calculations has been developed and tested.

Modular Coil Winding Dimensional Control Plan
NCSX-PLAN-MCWDC-00

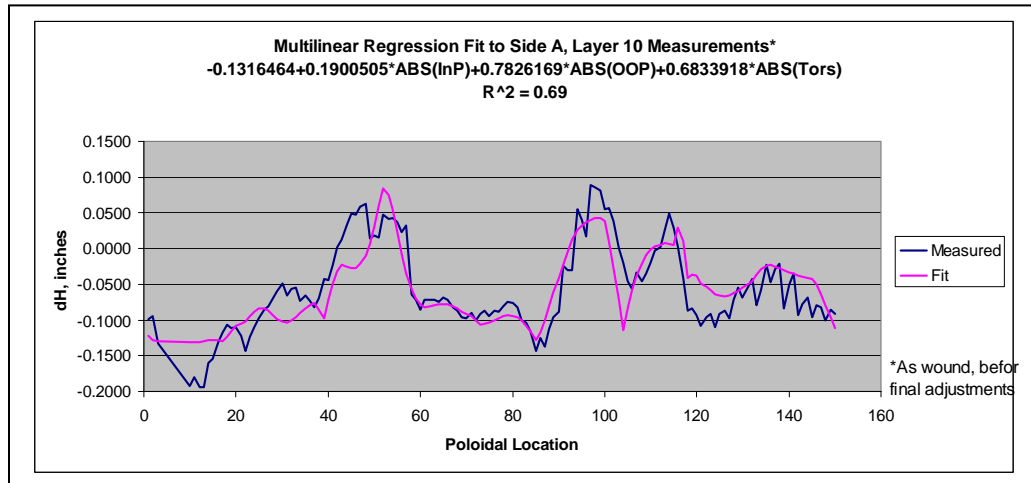

Figure 3-4 Fit to Measured Variation of Winding Pack Height on Side A of TRC Showing Correlation with In- and Out-of Plane Curvature and Torsion

- 3.1.11 Assess whether any shimming of the winding form is needed and where. Shimming is only be required in locations where the winding surfaces are so far out of tolerance that the deviation is beyond the range that can be compensated for by setting the side clamps (approximately $\pm 0.100''$).
- 3.1.12 Prepare an inspection report with sign-off for winding form measurements, comparison with measurements supplied by winding form vendor, calculated side clamp positions, and shim locations and thicknesses, if any.
- 3.1.13 Shim winding form where required. Use glass cloth tape underneath chill plates to shim.
- 3.1.14 Install cladding, taking care to minimize thickness of glue between winding surfaces and cladding.
- 3.1.15 *Measure cladding surfaces on base and septum using standard measurement pattern. Check that dimensions are consistent with winding surface measurements and nominal cladding thickness (0.040") plus any shims.*

Modular Coil Winding Dimensional Control Plan
NCSX-PLAN-MCWDC-00

3.2 Winding Station [Groundwrap & winding] Activities- Station 2 or 4

- 3.2.1 Install ground wrap, trimming as needed in bends to maintain uniform thickness.
- 3.2.2 *Measure winding surfaces on top of compressed ground wrap using standard measurement pattern. Check that dimensions add up to nominal thickness of cladding and compressed ground wrap plus any shims (cladding: 0.040"; compressed ground wrap: 0.045"-0.010"=0.035"; total buildup: 0.075").*
- 3.2.3 Install binding straps of ½"-wide, 0.004" thick glass tape on top of ground wrap and adjacent to clamps on both sides.
- 3.2.4 Measure cross sectional dimensions of conductor under standard clamping torque (30 in-lbs) for spools that will be used to wind side A. Measure both dimensions simultaneously. Use these conductor dimensions in predictions of desired winding pack dimensions. Use calipers with wide jaws for this measurement. Note that if these dimensions are significantly different from the nominal values, the calculations in step 3.1.10 should be repeated using the measured conductor dimensions.
- 3.2.5 For side A, set the side clamps parallel to the septum at the width of the winding pack calculated in step 3.1.10 using gauge blocks. Use shim washers to set side clamps. Record side clamp settings used.
- 3.2.6 Repeat the operation for the side B side clamps.
- 3.2.7 Wind side A to complete winding pack, reforming conductor by tamping as was done on TRC. Remove minimum number of clamps at a time necessary to work in a given region of the coil. Set top clamps to 30 in-lbs torque when clamps are replaced during winding. Use torque wrenches for which this torque value falls in the middle of the operating range.
- 3.2.8 Measure height and width of completed side A winding pack using standard measurement pattern.
- 3.2.9 *Measure cracks between turns on side of completed winding pack to determine if compression of pack is uniform.*

Modular Coil Winding Dimensional Control Plan
NCSX-PLAN-MCWDC-00

- 3.2.10 Use Romer arm to set top clamps to height of winding pack calculated in step 3.1.10. In places where this can not be achieved without exceeding 30 in-lbs torque on to clamps, get as close as possible.
- 3.2.11 Measure height and width of completed side A winding pack.
- 3.2.12 Wind side B, following same steps for side A (steps 3.2.4 through 3.2.11).
- 3.2.13 Adjust height and width of both winding packs starting with side A. This adjustment attempts to keep the current centroid of the coil within $\pm 0.020''$ of the design position at all locations. Work systematically in regions of 3-5 clamps, removing the minimum number of clamps necessary to work in a given region. Start in regions of the coil where the deviation of the height and width of the winding pack measured in steps 3.2.8 and 3.2.12 from the values calculated in step 3.1.10 is greatest. Set the top and side clamps to the values from the expressions in Section 2 of M. Zarnstorff's memo (Appendix 1), using the measured height and width (steps 3.2.8 and 3.2.12) to evaluate these expressions. Use the Romer arm to set the top clamps and adjust the shims to set the side clamps. Note that the expressions in Section 2 of Appendix 1 assume that the winding form septum surfaces are straight, perpendicular to the base, and in the desired orientation. More general expressions are needed if these conditions are not satisfied, e. g., if the septum is tilted or if the tee is rotated. Steps 3.2.13.1 through 3.2.13.9 below outline the winding pack adjustment steps.
- 3.2.13.1 Measure height and width of side A winding pack.
- 3.2.13.2 Readjust the side A winding pack to put height and width within $\pm 0.005''$ of calculated values where possible.
- 3.2.13.3 Measure height and width of side A winding pack.
- 3.2.13.4 Use expressions in Section 2 of Appendix 1 to calculate adjustments to side B winding pack required to put the overall current center of the coil at the design location. Use the measurements of the adjusted side A winding pack from step 3.2.13.3 and measurements of the side B winding pack from step 3.2.12 as input.
- 3.2.13.5 Adjust side B top and side clamps to calculated values.
- 3.2.13.6 Measure the height and width of side B winding pack.
- 3.2.13.7 Readjust the side B winding pack to put height and width within $\pm 0.005''$ of calculated values where possible.
- 3.2.13.8 Measure height and width of sides A and B of winding pack.

Modular Coil Winding Dimensional Control Plan
NCSX-PLAN-MCWDC-00

- 3.2.13.9 If the position of current centroid is not satisfactory, repeat adjustment of both sides (steps 3.2.13.1 through 3.2.13.8) using height and width measurements from step 3.2.13.8 to evaluate expressions in Section 2 of Appendix 1.
- 3.2.14 Measure height and width of both winding packs after adjustment is complete. Perform final analysis to verify that design position of current centroid of coil is achieved. Use final measurements of winding packs on both sides as input. Prepare a report with signoff.
- 3.2.15 Complete bindings of winding packs by tensioning them using tightening tool and attaching ends of glass tape together using double-sided tape while the glass tape is under tension. Make a mark on lever of tightening tool and pull lever to this point for each binding so that tension is reproducible. Place double sided tape on side of winding pack, leaving at least one inch of glass tape overlapped below the double-sided tape.
- 3.2.16 Perform final measurement of height and width of both winding packs after bindings are complete. Verify that completion of the bindings did not significantly change the pack dimensions.
- 3.2.17 Secure binding straps by painting about 1” of the overlapped region with room-temperature curing epoxy.
- 3.3 Winding Station [Post Groundwrap] Activities- Station 2 or 4**
- 3.3.1 Install the chill plates in regions of 3-5 clamps each. Remove the minimum number of clamps necessary to work in one part of the coil. Ensure that chill plates are in good contact with the winding packs. Reset top and side clamps to be snug to the chill plates.
- 3.3.2 Install the cooling tubes and solder them in place, removing the minimum number of clamps necessary to work in a given area. Reset top and side clamps to be snug to the chill plates.
- 3.3.3 Install co-wound magnetic diagnostic loops on top of the chill plates at the outer corner (away from the tee) of the winding pack. Measure location of loops with the Romer arm.
- 3.3.4 Install the bag mold, removing the minimum number of clamps necessary to work in a given area. Reset top and side clamps to be snug to the bag mold.

**Modular Coil Winding Dimensional Control Plan
NCSX-PLAN-MCWDC-00**

APPENDIX 1

Determining Clamping Target Deviations

M.C. Zarnstorff, 19 April 2005. V 2.

This note addresses two issues during the Modular Coil winding process: (1) How to position the winding clamps to adjust for a deviation in the machining of the winding form from the ideal CAD model; and (2) How to adjust the winding clamps if one of the desired clamp positions cannot be achieved. We will see that a solution is available in both cases that preserves the current center location.

We assume that the winding form T is straight, perpendicular to the base, and in the desired orientation. If these properties are not present, different compensating expressions for the clamp positions would be needed. It is also assumed that the turns uniformly distribute themselves within the overall coil pack, so that the current center can be controlled via the locations of boundaries of the winding packs.

1. Clamp positions to compensate for winding form deviations

Consider the following geometry of the two winding packs, separated by the winding T.

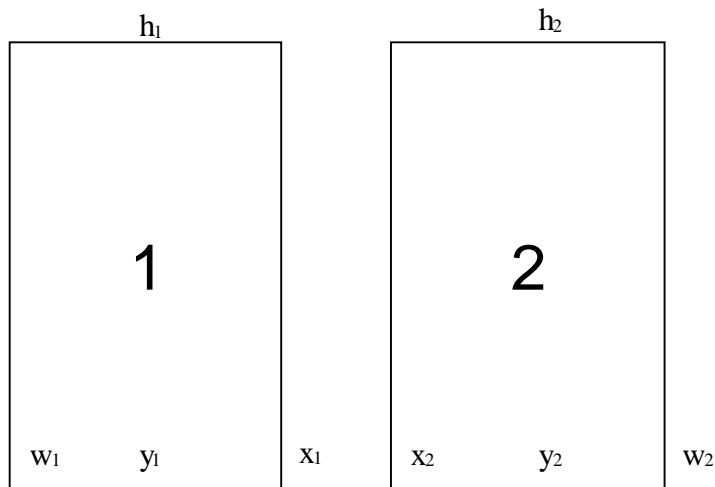

Let x_1, x_2 be the deviation in the horizontal location of the faces of the winding-T; y_1, y_2 be the deviation in the vertical location of the winding base. Let w_1, w_2 be the deviation in the horizontal location of the outside of the winding packs, as determined by the clamp locations. Let h_1, h_2 be the deviation of the vertical location of the tops of the winding packs, again determined by the clamps. In addition, let W and H be the design width and height of each winding pack.

Modular Coil Winding Dimensional Control Plan
NCSX-PLAN-MCWDC-00

Then, at each location along the length of the coil, the goal is to adjust the clamp positions (w_1, w_2, h_1, h_2) so that there is no deviation in the winding center location, while preserving the area WH of each winding pack. The equations representing these conditions are:

$$0 = y_1 + h_1 + y_2 + h_2, \quad (1)$$

$$0 = x_1 + w_1 + x_2 + w_2, \quad (2)$$

$$0 = H(x_1 - w_1) + W(h_1 - y_1), \quad (3)$$

$$0 = H(w_2 - x_2) + W(h_2 - y_2), \quad (4)$$

where terms second order in the perturbations have been neglected. When we prepare to wind the coil, the x_i and y_i are determined by measurements from the bare winding form, and we have four equations in four unknowns (the clamp positions). The solution for the desired clamp locations is:

$$h_1 = -\frac{H}{W}(x_1 + x_2) - y_2$$

$$h_2 = \frac{H}{W}(x_1 + x_2) - y_1$$

$$w_1 = -\frac{W}{H}(y_1 + y_2) - x_2$$

$$w_2 = \frac{W}{H}(y_1 + y_2) - x_1$$

If these clamp location perturbations are imposed and achieved, the winding form deviations will be completely compensated (without shims!).

Other types of fabrication deviations of the winding form are possible. For example, the T and the base may not be perpendicular. Or, the T and base may be rotated relative to their design orientation. These types of distortions can probably also be compensated for, but have not been analyzed yet.

2. Adjusting clamp positions for conductor winding deviations.

What if we cannot achieve the desired clamp locations during the winding process? This occurred on the TRC in regions of strong twisting, and represents a non-recoverable change in the total area required for the windings. During the winding process, this will initially take the form of the height of the pack being incorrect, as the horizontal clamp location will (presumably) be fixed at the desired location. Let $\tilde{W}_{1,2}$ and $\tilde{H}_{1,2}$ be the achieved width and height of each winding pack at a particular location under standard conditions (e.g. 35 in-lbs. torque on the top clamp). Define $x_{1,2}, y_{1,2}, h_{1,2}$, and $w_{1,2}$ as before, as deviations relative to the design locations.

Assuming that the new area of the winding packs can be preserved when adjusting the clamps, equations (3) and (4) become:

$$S_1 \equiv \tilde{W}_1 \tilde{H}_1 - WH = H(x_1 - w_1) + W(h_1 - y_1), \quad (3')$$

$$S_2 \equiv \tilde{W}_2 \tilde{H}_2 - WH = H(w_2 - x_2) + W(h_2 - y_2), \quad (4')$$

Modular Coil Winding Dimensional Control Plan
NCSX-PLAN-MCWDC-00

where terms second order in the perturbations have been neglected again. Again we have four equations in four unknowns. The solution is:

$$h_1 = -\frac{H}{W}(x_1 + x_2) - y_2 - \frac{1}{2W}(S_2 - S_1),$$

$$h_2 = \frac{H}{W}(x_1 + x_2) - y_1 + \frac{1}{2W}(S_2 - S_1),$$

$$w_1 = -\frac{W}{H}(y_1 + y_2) - x_2 - \frac{1}{2H}(S_2 + S_1),$$

$$w_2 = \frac{W}{H}(y_1 + y_2) - x_1 + \frac{1}{2H}(S_2 + S_1).$$

Again, we see that the winding center location can be preserved precisely without the need for shims.