

NCSX Engineering Design Document

Design Description

Central Instrumentation and Control (WBS 5)

NCSX CDR

May 21-23, 2002

Lead Author: Gary Oliaro

Table of Contents

1	Introduction.....	1
2	Design Requirements and Constraints.....	1
3	Design Description and Performance.....	3
4	Design Basis.....	9
5	Design Implementation.....	9
6	Reliability, Maintainability, and Safety.....	10
7	Cost, Schedule, and Risk Management.....	10

Table of Figures

Figure 1	Schematic of Network Infrastructure.....	4
Figure 2	Shared Plasma Control Systems.....	6
Figure 3	NCSX Control Room Conceptual Layout.....	8

Tables

Table 1	Central I&C (WBS 5) Costs.....	10
---------	--------------------------------	----

1 INTRODUCTION

The Central Instrumentation and Control System (WBS 5) will provide the remote control and monitoring, diagnostic data acquisition and data management for the various subsystems on NCSX. This WBS includes seven elements, which are all related to the primary mission of WBS 5. They are:

- TCP/IP Network Infrastructure (WBS 51)
- Central Facilities I&C (WBS 52)
- Diagnostic Data Acquisition and Facility Computing (WBS 53)
- Facility Timing and Synchronization (WBS 54)
- Real Time Plasma and Power Supply Control (WBS 55)
- Central Safety and Interlock System (WBS 56)
- Control Room Facility (WBS 57)

2 DESIGN REQUIREMENTS AND CONSTRAINTS

TCP/IP Network Infrastructure

The TCP/IP Network Infrastructure will provide the common backbone for all data acquisition, and I&C communications.

- Network Communications for critical and high-energy subsystems are required to be protected from intrusion from the local PPPL network and the wide area.
- Network Communications for critical protective systems will be implemented with dual power supply switches fed from house and UPS sources.
- The network is required to operate in a high noise environment close to the machine and its power sources.
- Isolation of diagnostic data acquisition network traffic and the facility subsystems network traffic is required to insure that high data load will not impact facility control and monitoring.
- A fiber optic facility will be required for the Timing and Synchronization System, diagnostic video cameras and real time plasma control system communications.

Central Facilities I&C

A central process control system will provide supervisory control and monitoring (with a common user interface), to all engineering subsystems and high-energy systems. It must be a distributed control system (DCS) to provide communication to remote I/O throughout PPPL using standards based network protocols.

- The central process control system will provide the synchronization between two or more operating machines at PPPL using shared power conversion resources.
- The central process control system will provide current and historical trending, alarm logging, mimic displays, machine state archival, and process control and monitoring functions for NCSX.

Diagnostic Data Acquisition and Facility Computing

The Diagnostic Data Acquisition System will provide a data management software structure to catalog and manage experimental results for subsequent retrieval and analysis.

- It will be a “shot” mode time system where initialization sequences are started before the experimental discharge, and data archival is completed at some period after the discharge. This period must be shorter than the maximum repetition rate of NCSX.

- Access to current Engineering process control data will be required for diagnostic operations.
- All experimental data, for the life of the machine, will be available online, on fast rotating magnetic storage.
- To achieve high performance and fault tolerance, all experimental data will be stored on RAID 5 storage units with dual power supplies, battery backup cache RAID controllers, with online spare disks which will be automatically configured into the RAID set after a disk failure.
- Three copies of the raw data will be archived, one nightly backup of the local data acquisition computer, one nightly backup of the central data server, and one copy of the raw data will be continuously maintained for the life of NCSX on the central RAID 5 storage array.

Facility Timing and Synchronization

The Facility Timing and Synchronization System will provide up to 256 preprogrammed events triggers to define the NCSX shot cycle.

- One master clock encoder using a fiber optic broadcast transmission system will provide event triggers for all timing receivers used throughout the NCSX facility.
- The timing resolution will be no greater than 100ns. The timing facility will provide +/-1 microsecond or less simultaneity for diagnostic data acquisition and engineering facilities.

Real Time Plasma and Power Supply Control

The real time software is divided into two functions, the Power Supply Real Time Control System (PSRTC) and the Plasma Control System (PCS). The PSRTC will calculate the alpha control signal required by the power conversion firing generators. This signal is calculated using coil currents, machine state permissives, and fault conditions. The PCS can also provide inputs to the PSRTC algorithms. The PCS will use the existing user-interface/data server software system developed at General Atomics. It consists of real time "control category" routines (i.e. gas, shape, position, etc.), a waveform manager, hooks to IDL user interfaces and internal messaging and lock management software. The data acquisition system will include 64 digitizer channels for magnetics sensors in the test cell.

Central Safety and Interlock System

The Central Safety Interlock System will provide system wide coordination of personnel and hardware interlocks. Its primary man machine interface will be EPICS.

- The Central Safety Interlock System will be designed using fail-safe design techniques.
- Each NCSX high-energy subsystem will interface with the Central Safety Interlock System. The subsystem will be responsible for ensuring that the design of its interlocks and safety features are adequate.
- An access control system will be incorporated to grant access to the Test Cell for only authorized/trained personnel.
- UPS and Standby power will be used for critical components.

Control Room Facility

The Control Room Facility will provide a centralized location for researchers (PPPL physicists, engineers and collaborators) to direct and monitor the experimental operation of NCSX.

- Raised flooring will be required to route network, fiber optic, and power cables to the control racks and Operator Interface Units located in this area.
- A minimal space of 3200 square feet will be required to support a similar level of activity as presently seen in the NSTX Control Room.
- A "Comfort Display" system capable of displaying 24-36 waveforms in a central location is required for Physics Operations planning.
- Telecommunications, test cell video and audio, and a test cell PA system will be required in the control room.

- Control Room workstation tables and chairs will be required.

3 DESIGN DESCRIPTION AND PERFORMANCE

TCP/IP Network Infrastructure

The TCP/IP network Infrastructure will provide a minimum of 100Mbps Ethernet connectivity to all facilities and users of NCSX. Uplink and backbone bandwidth of Gigabit Ethernet or faster will be deployed. The network will consist of three distinct branches: Physics, Engineering and Plant networks. A schematic of the Network Infrastructure is provided in Figure 1. The Physics Network will support all users and diagnostic control. The Engineering network will support facility and high-energy subsystems, while the Plant network will provide connectivity for low level PLC communications. The Engineering and Plant networks will be behind a secure firewall. The NCSX Physics and Engineering network branches will be extensions of the corresponding NSTX networks.

The primary switch hubs will be deployed in five locations:

- D-Site FCPC for Power conversion and Plasma Control
- D-Site MG
- C-Site S1 area for RF connectivity
- C-Site NCSX Control Room for Test Cell, NBI connectivity
- PPLCC for facility computing

NCSX will use the existing network fiber optic infrastructure between C-site and D-site. Several short fiber optic runs will be installed at D-site and at C-site to include new NCSX hubs. Two fiber optic distribution panels will be located in the Test Cell on each side of the machine.

A fiber optic infrastructure will also be deployed for facility timing and synchronization.

- 12 fiber optic cables between C-Site and D-Site will be deployed for “utility” I&C requirements.
- 96 Diagnostic fiber optic cables for video cameras and other diagnostic requirements will be deployed between the control room and the test cell.
- 12 fiber optic cables between C-Site and D-Site will be deployed for real time plasma control communications.

Wireless Ethernet transceivers will be deployed in the test cell to aid in troubleshooting, and also in the control room for use by collaborators.

Figure 1 Schematic of Network Infrastructure

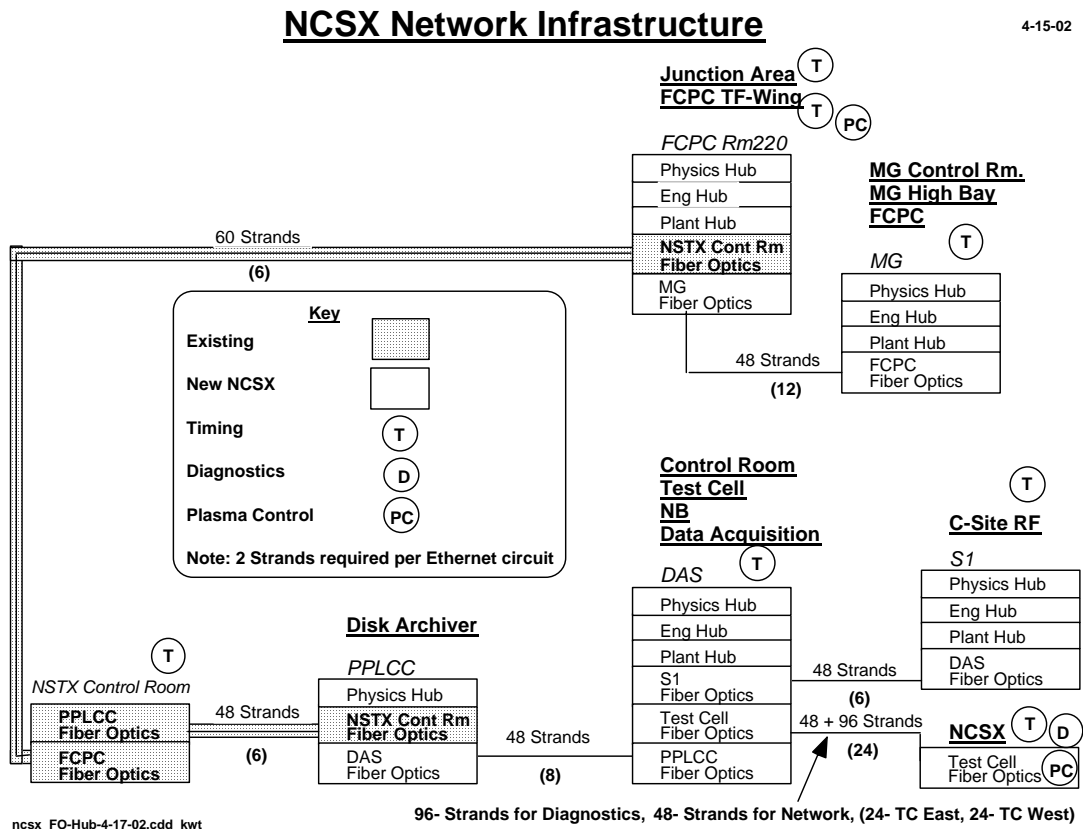

Central Facilities I&C

The central process control system will be designed using the Experimental Physics and Industrial Control System (EPICS). This system is maintained through a global collaboration, principally at Argonne National Laboratories (ANL). EPICS is a set of software tools and applications used worldwide to develop distributed control systems for large scientific experiments. ANL is the repository for the operational and beta releases of these tools and supports an active worldwide development community. As a DOE-funded facility, EPICS is free to PPPL.

A total of 14 Input Output Controllers (IOC) will be deployed for the following subsystems:

- WBS 21 Fueling Systems
- WBS 22 Vacuum Pumping Systems
- WBS 23 First Wall Conditioning Thermocouples for Bakeout, GDC
- WBS 24 RF Heating Systems, ICH
- WBS 25 Neutral Beam Heating Systems
- WBS 42 Motor Generators
- WBS 43 Magnet Power Systems
- WBS 62 Water Systems
- WBS 63 Cryogenic Systems

Each IOC will consist of chassis, CPU, Ethernet interface, timing & synchronization interfaces, interfaces to common commercial hardware such as Allen-Bradley PLC I/O and Data-Highway plus, and digital and analog I/O.

CPU and I/O will be primarily based on the PCI bus. The format is now envisioned as Compact PCI (CPCI), however the less expensive generic PCI format of the common PC architecture is also attractive. VME equipment may be deployed and is fully supported by EPICS. Due to age and maintenance issues of PPPL's existing CAMAC inventory, it will not be used in the design. It should be noted, however, that CAMAC is supported by EPICS tools.

The IOC will run the EPICS Channel Access protocol and act as a data server to remote Channel Access clients. A Channel Access gateway will be used to provide EPICS clients on the Physic network with secure access to the engineering conditions, such as the shot cycle events and shutter status.

EPICS Display client software will be running on 11 Operator Interface Units (OIU) in the NCSX control room and throughout the facility. These OIUs will display process control system status displays, current and historical trending, alarm logging, mimic displays, and control and monitoring displays.

Diagnostics Data Acquisition and Facility Computing

The design will use the existing MIT developed MDSplus software for data acquisition, data archiving and display. Individual diagnostic local control and data acquisition hardware will be designed with standard PC architecture or in Compact PCI chassis. 8 diagnostic operator interface units will be configured and deployed for day 1 operations. Approximately 7 PC's or CPCI units with I/O channels, as specified by WBS3, will be purchased and deployed for day 1 operations. Legacy CAMAC will not be used in the design of the NCSX DAS.

An additional facility compute server/cluster, tape library expandable to 0.5PB-1.0PB, and disk storage area network (RAID 5) will be deployed for the data acquisition system.

An NCSX Computing Interface Specification will be developed for use at PPPL and for remote collaborators. The standard will be composed of a set of interfaces specifications to MDSplus, Timing Systems, EPICS, Inter-process Communications (IPCS), and networking which when used, will insure a smooth integration of diagnostics into the DAS. For example, the MDSplus specification will include interface specifications for Labview VIs, IDL functions, Visual Basic DLLs, COM objects, VC++ DLLs, Java, Fortran and EPICS.

The Data Acquisition System will make use of existing PPPL compute and data storage resources as much as possible. Additional capacity will be added to meet NCSX requirements. Due to rapidly changing technology, the software and hardware which will be deployed will be reviewed as the start of operation approaches.

Facility Timing and Synchronization

A new timing and synchronization technology is required for NCSX. The CAMAC based TFTR Timing System was developed in the late 70's. Typical resolution was 1ms for periods over 1 second. A requirement to use off-the-shelf or existing solutions for NCSX is highly desirable.

A VME based system from BNL used on the Relativistic Heavy Ion Collider (RHIC) is being investigated. This system is used on the Spallation Neutron Source (SNS) at ORNL and will provide the basis for the NCSX design.

Design specifications include:

1. Timing granularity of 100ns
2. Overall accuracy +/- 1us with asynchronous event contention
3. 256 event triggers
4. Fiber optic broadcast transmission

This activity will provide the engineering to convert the existing SNS V102 timing modules to CPCI and PCI formats. Additional manpower to write software drivers will also be provided.

Figure 2 Shared Plasma Control Systems

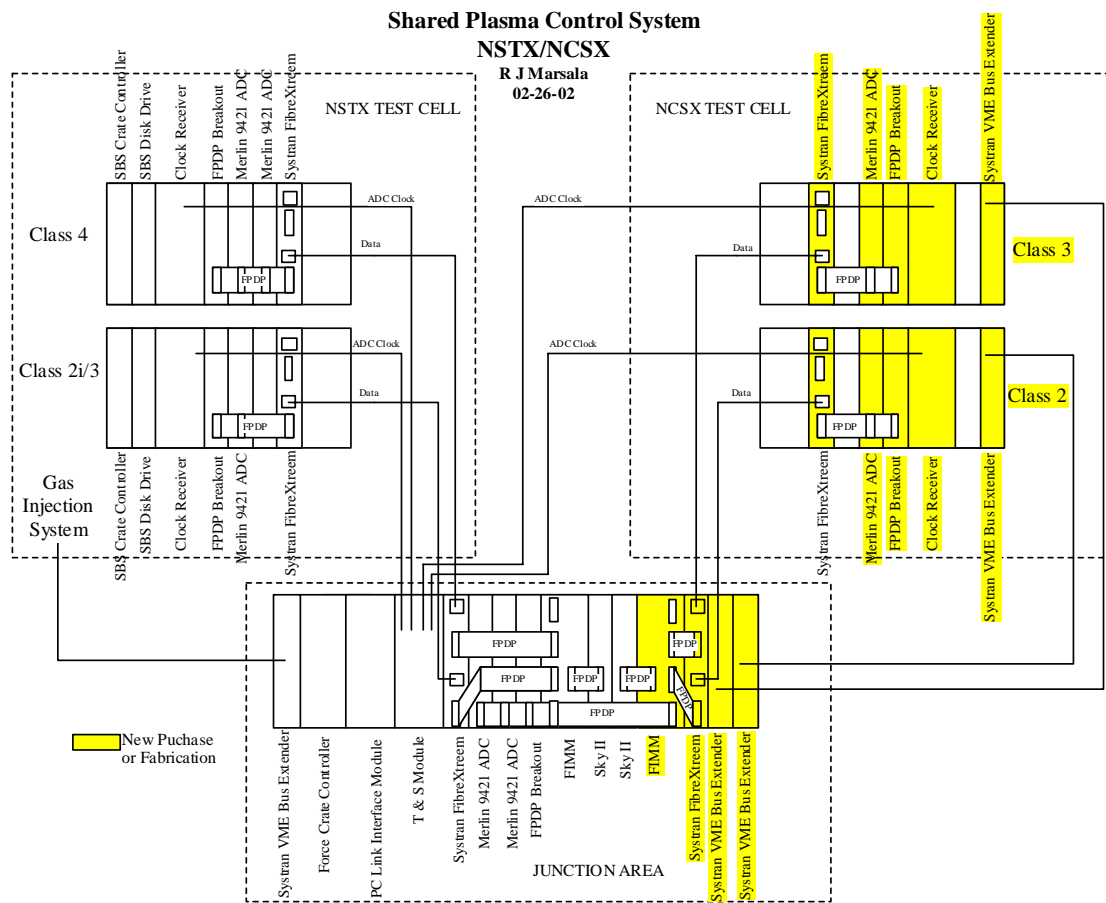

Real Time Plasma and Power Supply Control

Real Time Plasma Control System will share portions of the control system used for NSTX. The NSTX system consists of a Sky Computer Inc. high-speed array processors and a Force Inc. host control computer, a real time data acquisition system and Fiber Channel Communication links to remote digitizers.

The PCS will use the existing user-interface/data server software system developed at General Atomics. It consists of real time “control category” routines (i.e. gas, shape, position, etc.), a waveform manager, hooks to IDL user interfaces and internal messaging and lock management software. The alpha control signal will be sent to the power supply building via a custom designed fiber link, however a new link may be in place in 2005.

NCSX will require a new real time data acquisition system in the NCSX test cell. It will consist of 64 ADC channels, timing and clock interfaces, Digital I/O, and a communication interface to the existing NSTX real-time processor at D-Site. Sysran FiberExtreem Fiber Channel communications links will provide real time data transfer between the two voltage classes in the Test Cell and Power Supply building The Day 1 system will consist of a new PSRTC to support NCSX requirements. The PCS infrastructure will be available for limited plasma control on Day 1, however, the system will be capable of expansion to several hundred real time signals.

Central Safety and Interlock System

The Central Safety Interlock System will be a fail-safe, hybrid system. Mechanical components and hardwired devices will provide primary protective functions. To reduce the cost of system maintenance and to support flexible operational scenarios, secondary safety and interlock functions will use a redundant PLC system that will be distributed throughout the NCSX facility.

Each NCSX high-energy subsystem will interface with the Central Safety Interlock System. The access control system will interface with the Central Safety and Interlock System to grant access to the Test Cell for only authorized/trained personnel. UPS and Standby power will be used to power critical components. To aid operations, the primary man machine interface will be EPICS.

Control Room Facility

The PLT and PBX control room area is approximately 2400 sq. ft. Approximately 1400 sq. ft. of the contiguous PLT DAS computer area will be integrated with the main control room for a total of 3800 feet, providing ample space for research and operations staff. Approximately 600 sq. ft. of this space, adjacent to the test cell wall, will be reserved for diagnostic instrumentation racks. A layout of the control room area is provided in Figure 3.

WBS57 will be responsible for providing the following facilities:

Installation of raised flooring.

- Installation of 25 dual workstation tables wired for network and power.
- Installation of 6-12 equipment racks wired for network and power.
- Expandable closed circuit TV system with 3 PTZ cameras
- Test Cell PA system
- Diagnostic machine microphones data included in MDSplus tree
- Dual screen, multi window “comfort” display system
- Wireless Ethernet for the Physics network to support visitors and laptop computers

Figure 3 NCSX Control Room Conceptual Layout

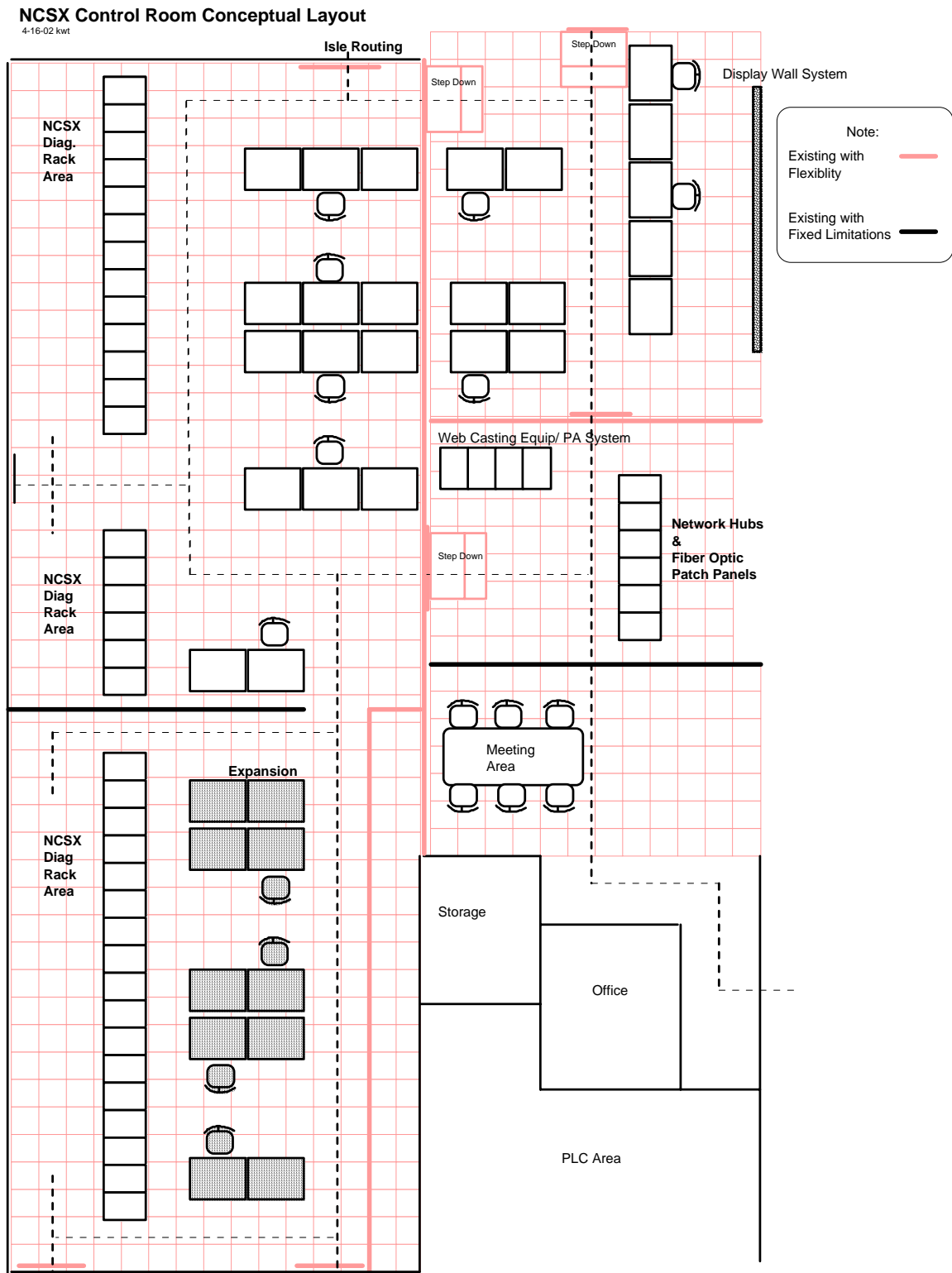

4 DESIGN BASIS

TCP/IP network Infrastructure

The design basis for the NCSX network infrastructure is the model used on NSTX and the network technology used for the growth of the PPPL network. Since PPPL Network Engineering staff will be responsible for this design we are assured of component commonality with the much larger PPPL network infrastructure.

Central Facilities I&C

The design basis for the NCSX Central I&C system is EPICS, which is also being used on NSTX. All system software and hardware components have been used and tested on NSTX and a group of experienced personnel is available for design and implementation. Since the beginning of 2001, PPPL has moved from using CAMAC instrumentation to PCI based technologies. Our experience with these technologies indicates that they are the proper choice for NCSX.

Diagnostic Data Acquisition and Facility Computing

The design basis for the NCSX Diagnostic Data Acquisition System is the MIT developed MDSplus, which is also being used on NSTX. All system software and hardware components have been used and tested on NSTX and a group of experienced personnel is available for design and implementation.

Facility Timing and Synchronization

The design basis for Facility Timing and Synchronization is a VME based system from BNL used on the Relativistic Heavy Ion Collider (RHIC) and on the Spallation Neutron Source (SNS) at ORNL. This is not a commercial product, however, documentation packages are available for immediate manufacturing. We expect that this system will mature over the next few years and possibly be available in CPCI and PCI formats, which will make this product the universal timing solution for NCSX.

Real Time Plasma and Power Supply Control

The design for the plasma control system will be based on the current VME design used on NSTX. We will share the existing array processor and current monitoring digitizers with NSTX since the power conversion system will be shared. The NSTX PCS software from GA will also be the framework for the NCSX design.

Central Safety and Interlock System

The experience with the NSTX safety interlock and access control system is not applicable to NCSX since we used the existing TFTR interlock and access control system. However, the principles of failsafe operation, and redundancy are well understood and a group of experienced personnel is available for design and implementation.

Control Room Facility

The design for the NCSX Control Room Facility will be based on the current NSTX control room.

5 DESIGN IMPLEMENTATION

Except for the WBS 54 Facility Timing and Synchronization System, all WBS 5 elements are to be designed with commercial off the shelf (COTS) components with delivery times of under 6 weeks. The acquisition strategy will be just-in-time purchase to take advantage of the current technologies.

Most components of the WBS 54 Facility Timing and Synchronization System have already been designed and implemented for other DOE projects (e.g. the RHIC and SNS projects). Documentation (design, fabrication, test, and procurement) of these components will be acquired from the other DOE laboratories for NCSX. Fabrication of the equipment will be straightforward, and will be implemented using the best available methods.

Since most of the hardware is COTS, assembly, installation, and testing will follow NCSX and industrial methods for subsystem assembly, installation, and testing. No special requirements apply.

6 RELIABILITY, MAINTAINABILITY, AND SAFETY

The reliance on COTS equipment for non-safety control and data acquisition applications promotes a cost-effective and reliable system. An onsite supply of spare parts will be available for the majority of the equipment. Support subcontracts for commercial software and selected hardware components will be used to provide special support from the commercial sector. The use of COTS promotes (long-term) maintainability because the commercial market supports an adequate supply of compatible replacement parts. For safety-related controls, a fail-safe philosophy and several layers of redundancy have been incorporated into the system design for high reliability and safety.

7 COST, SCHEDULE, AND RISK MANAGEMENT

Table 1 is a summary of estimated costs for Central Instrumentation and Control in the NCSX Fabrication Project. The total cost is estimated to be \$3997K in year of expenditure dollars with an overall contingency of 10%. The relatively low contingency is due to the very accurate and recent picture of the labor hours and M&S costs associated with this work on NSTX.

The schedule for implementing Central Instrumentation and Control may be seen in the Project Master Schedule, provided as part of the Conceptual Design Report. Central Instrumentation and Control design will generally be completed quite late in the Project, around mid-FY06. Installation and testing will occur in parallel with machine assembly during the months preceding first plasma in mid-FY07.

The cost, technical, and schedule risks for Central Instrumentation and Control are low. The primary basis for this is that NCSX is using proven hardware and software components. The COTS computing, networking, and process control hardware are widely applied in many industries. Specialized hardware and software components have been used for several projects at several laboratories, including NSTX. Where the technology has not yet been fully developed, such as MDSplus serving on Unix, or the Timing System’s PCI circuit board, prototypes will be used to verify the design. Collaborators can also provide technical expertise for components such as MDSplus, EPICS, and the Timing System, which will also lower the risks.

Table 1 Central I&C (WBS 5) Costs

Total Estimated Cost (K\$)		51 Total	52 Total	53 Total	54 Total	55 Total	56 Total	57 Total	5 Total
Manufacturing Development	Labor/Other								
	M&S								
	Total								
Design (Title I & II)	Labor/Other	45	300	103	167	56	56	33	761
	M&S		7	7	3				16
	Total	45	307	109	171	56	56	33	777
Fabrication/Assembly (incl Title III)	Labor/Other	366	328	156	404	230	214	147	1846
	M&S	289	314	372	66	74	127	132	1374
	Total	655	642	528	471	304	341	279	3220
Installation/test	Labor/Other								
	M&S								
	Total								
Grand Total		700	949	637	641	360	397	312	3997