

8

7

6

5

4

3

2

1

NEXT ASS'Y: 1 FINAL ASS'Y:

- NOTES
1. INTERPRET DRAWING PER MECHANICAL ENGINEERING DRAFTING STANDARD ES-3.1-2.
 2. INTERPRET DIMENSIONS AND TOLERANCES PER ANSI Y14.5M.
 3. DIMENSIONS ARE IN IN OR MM.

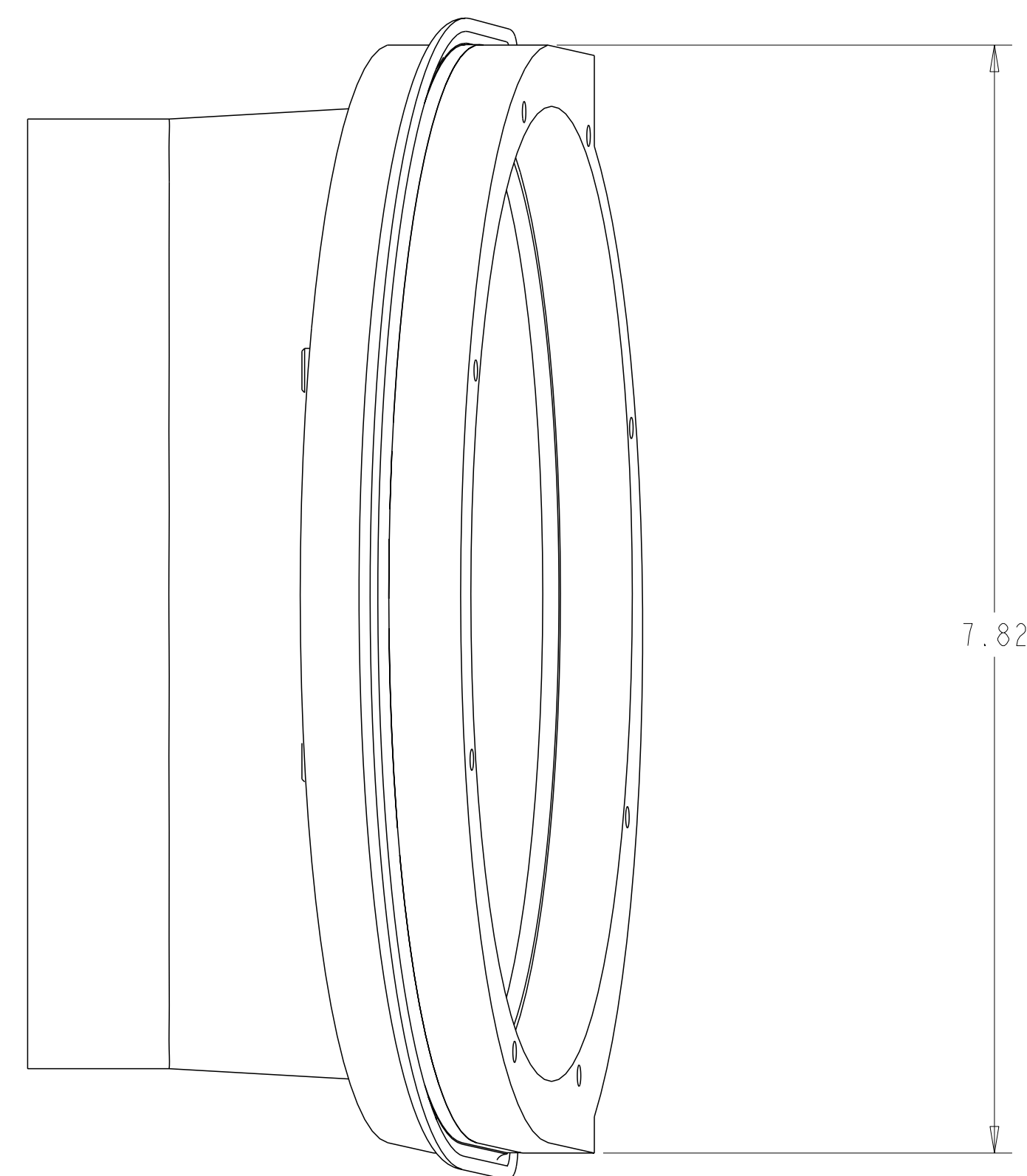
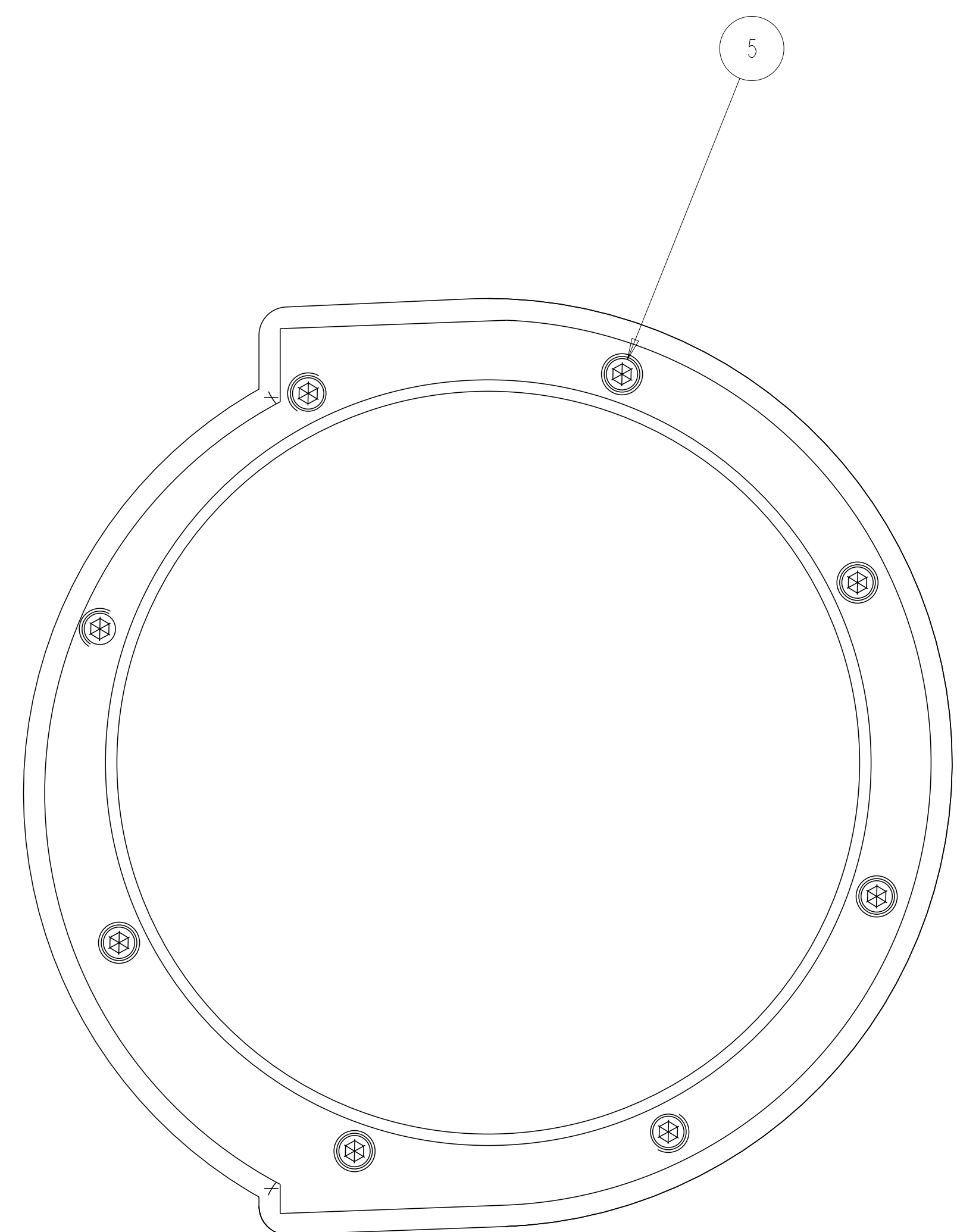
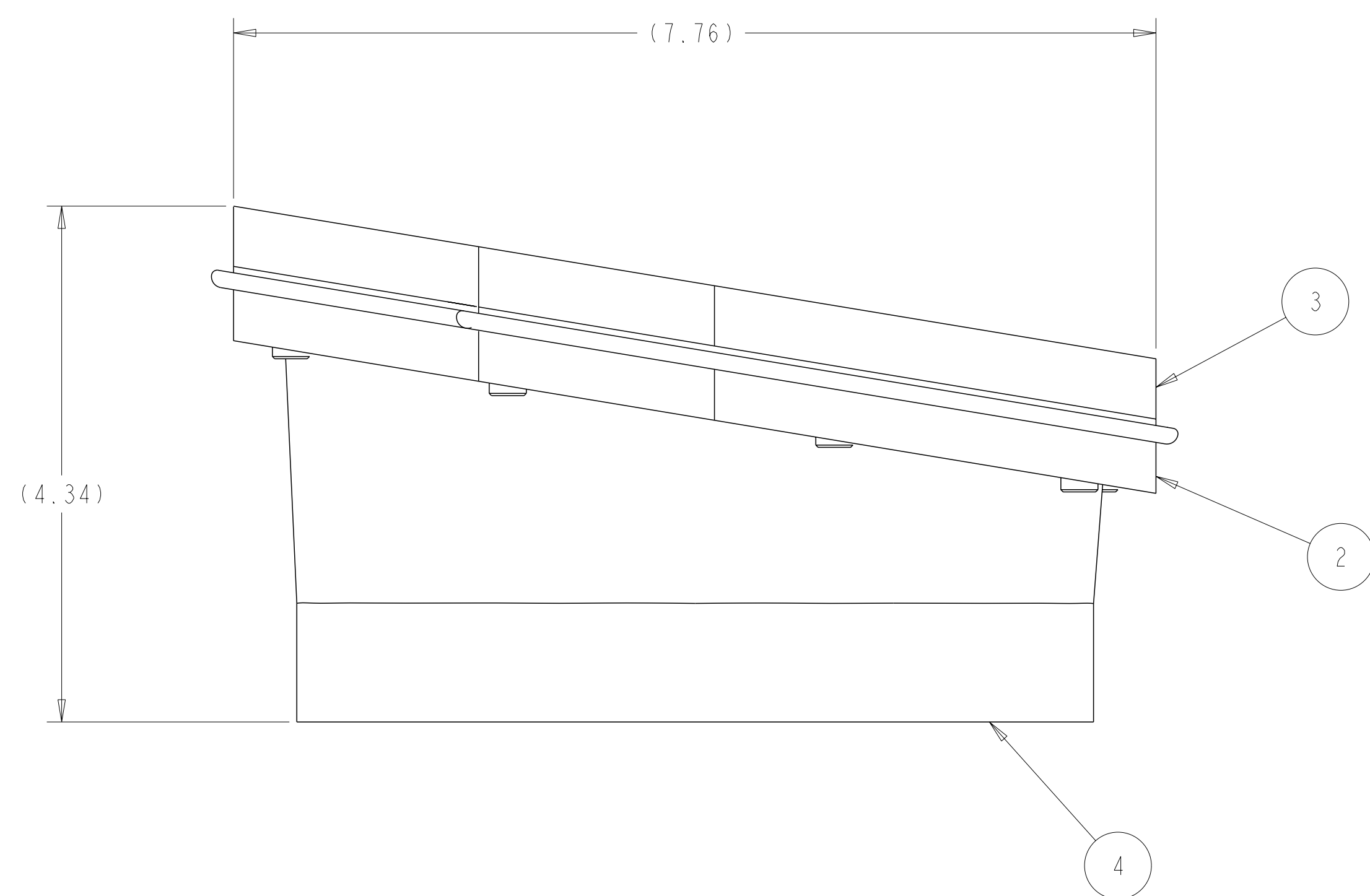

SCALE 1.000

REV	DESCRIPTION	BY	DATE	CHK	DEPT	DATE	PE	REQ	DATE	ORNL	DOE	DATE
0	ORIGINAL ISSUE											
1												

SCALE	NOTED	DES	DESIGNER	XX
	TOLERANCES UNLESS OTHERWISE SPECIFIED	CHK	DETAILER	XX
	FRACTIONS	SECT		
	XX DECIMALS ±.01	DEPT		
	XXX DECIMALS ±.005	PE		
	ANGLES ±0°15'	CR		
	BREAK SHARP EDGES .06 MAX	PJ		
	FINISH .125 UNLESS OTHERWISE SPECIFIED	RED		
		PPPL	DRFT	

CAGE CODE	PART OR IDENTIFYING NO	NOMENCLATURE OR DESCRIPTION	MATERIAL	SPECIFICATION	FIND NO
	-5	SHCS-10-24 X 1			5
	SE122-343-1	PORT 2 WINDING FORM SEAL BOOT			4
	SE122-342-1	PORT 2 WINDING FORM SEAL INNER PLATE			3
	SE122-341-1	PORT 2 WINDING FORM SEAL OUTER PLATE			2
	-1	PORT 2 WINDING FORM SEAL ASSEMBLY			1

← NEXT ASSEMBLY

PARTS LIST

NO REPRESENTATION OR WARRANTY, EXPRESSED OR IMPLIED, IS MADE AS TO THE ACCURACY, COMPLETENESS OR USEFULNESS OF THE INFORMATION OR STATEMENTS CONTAINED IN THESE DRAWINGS, OR THAT THE USE OR DISCLOSURE OF ANY INFORMATION, APPARATUS, METHOD OR PROCESS DISCLOSED IN THESE DRAWINGS MAY NOT INFRINGE PRIVATE RIGHTS OF OTHERS. NO LIABILITY IS ASSUMED WITH RESPECT TO THE USE OF, OR FOR DAMAGES RESULTING FROM THE USE OF, ANY INFORMATION, APPARATUS, METHOD OR PROCESS DISCLOSED IN THESE DRAWINGS. DRAWINGS MADE AVAILABLE FOR INFORMATION TO BIDDERS ARE NOT TO BE USED FOR OTHER PURPOSES, AND ARE TO BE RETURNED UPON REQUEST OF THE FORWARDING CONTRACTOR.

P THIS DRAWING PRODUCED ON PRO-ENGINEER

REV	DESCRIPTION	BY	DATE	CHK	DEPT	DATE	PE	REQ	DATE	ORNL	DOE	DATE
0	ORIGINAL ISSUE											
1												

Oak Ridge National Laboratory
managed for the DEPARTMENT OF ENERGY under
U.S. GOVERNMENT CONTRACT DE-AC05-00OR2225
UT-BATTELLE, LLC, Oak Ridge, Tennessee

UT-BATTELLE

NATIONAL COMPACT STELLARATOR EXPERIMENT

PORT 2 WINDING FORM SEAL ASSEMBLY

VERSION NO.	PLANT	BLDG	FL	SHT	OF	TYPE	CLASS
1	ORNL	5700	3	1	1	A	U

RELEASE LEVEL: prot.release

SE122-340

REV 0

8

7

6

5

4

3

2

1

SE122-340