

NOTES

1. INTERPRET DIMENSIONS AND TOLERANCES PER ANSI Y14.5M.
2. DIMENSIONS ARE IN INCHES
3. WELDING PROCEDURES AND PERFORMANCE QUALIFICATIONS SHALL BE PERFORMED IN ACCORDANCE WITH THE REQUIREMENTS OF ASME CODE, SECTION IX. WELDS MAY BE MADE BY THE GTAW OR GMAW PROCESSES. WELDS USING SMAW PROCESS ARE NOT PERMITTED.
4. WELD INSPECTIONS SHALL BE PERFORMED BY VISUAL EXAMINATION: ALL WELDS ARE TO BE VISUALLY INSPECTED IN ACCORDANCE WITH ARTICLE 9, SECTION V OF THE ASME CODE. WELDS DESIGNATED WITH A VT IN THE REFERENCE AREA OF A WELD SYMBOL SHALL ALSO BE VISUALLY EXAMINED WITH 8X MAGNIFICATION. IN ACCORDANCE WITH ARTICLE 6, SECTION V OF THE ASME CODE, THE ACCEPTANCE CRITERIA FOR THE VISUALLY INSPECTED WELDS IS GIVEN IN AWS D1.6, PARAGRAPH 6.29.1.

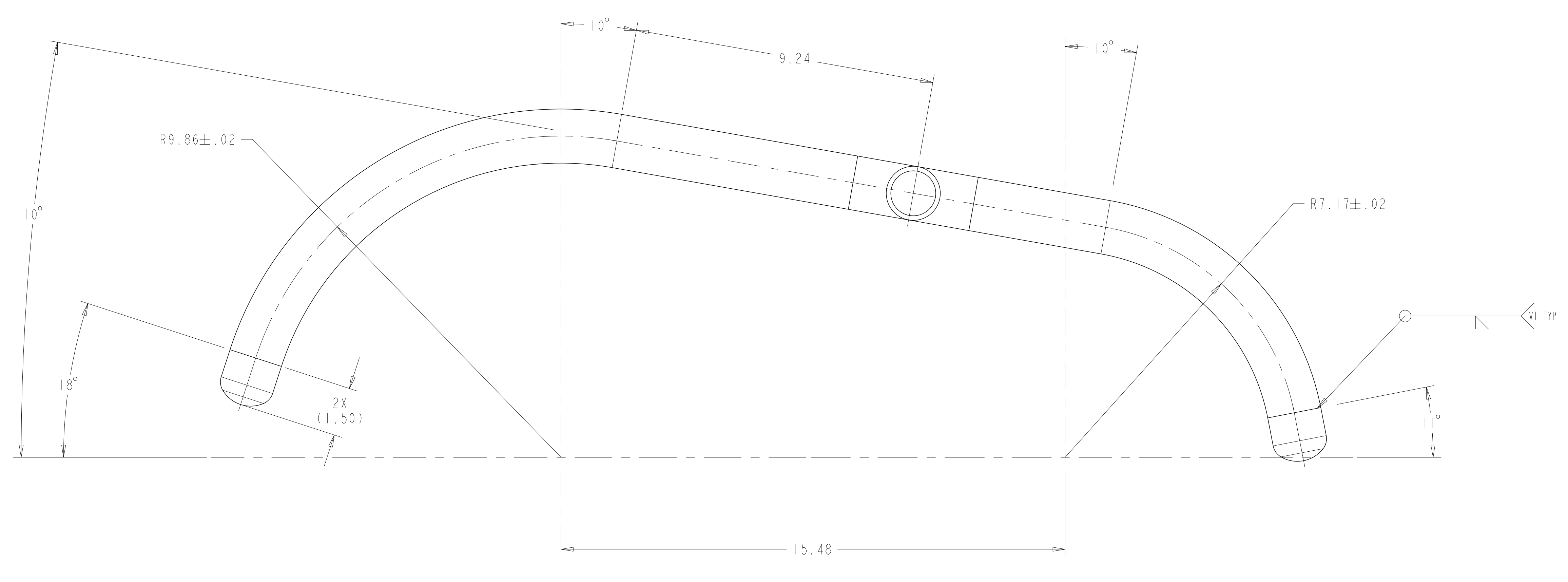

VIEW FOR TUBE FABRICATION

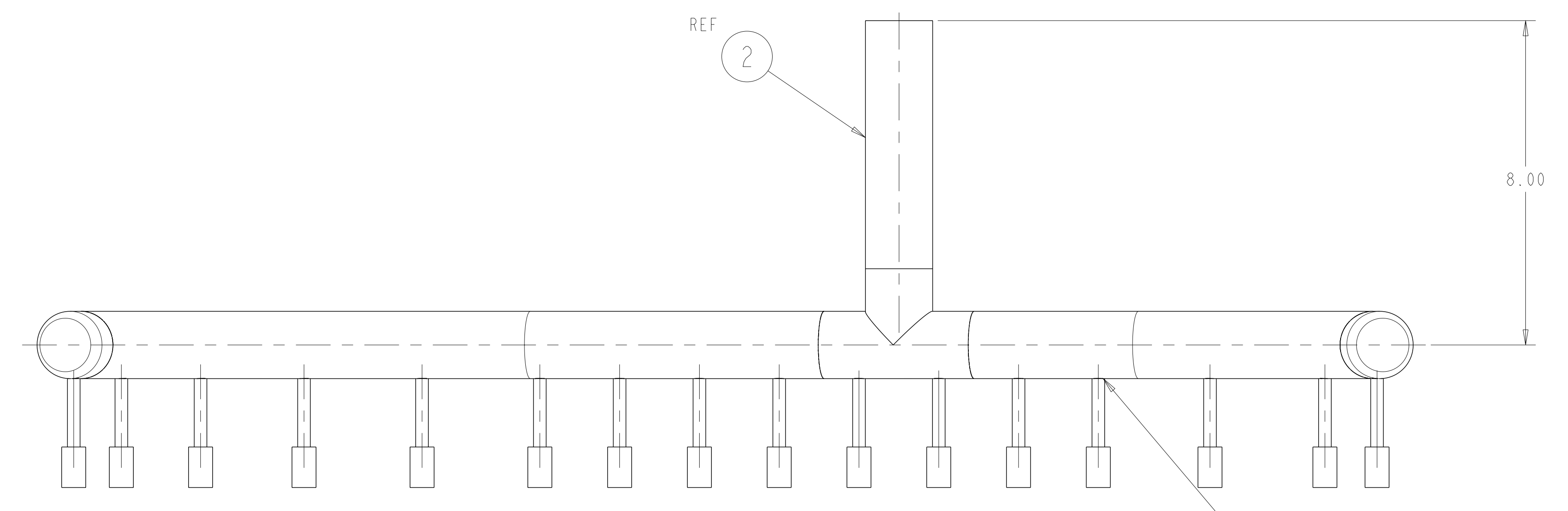

ISOMETRIC VIEW
SCALE 0.500

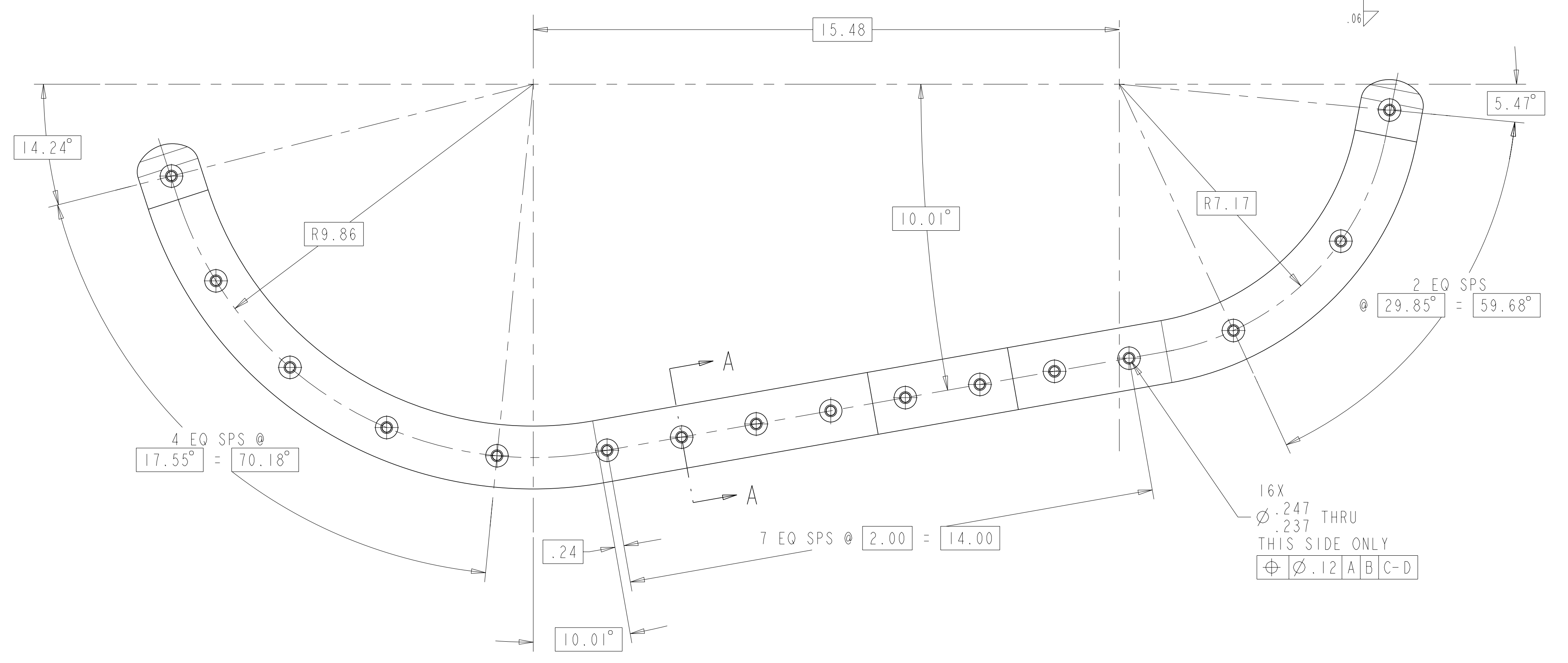

VIEW FOR HOLE LOCATION

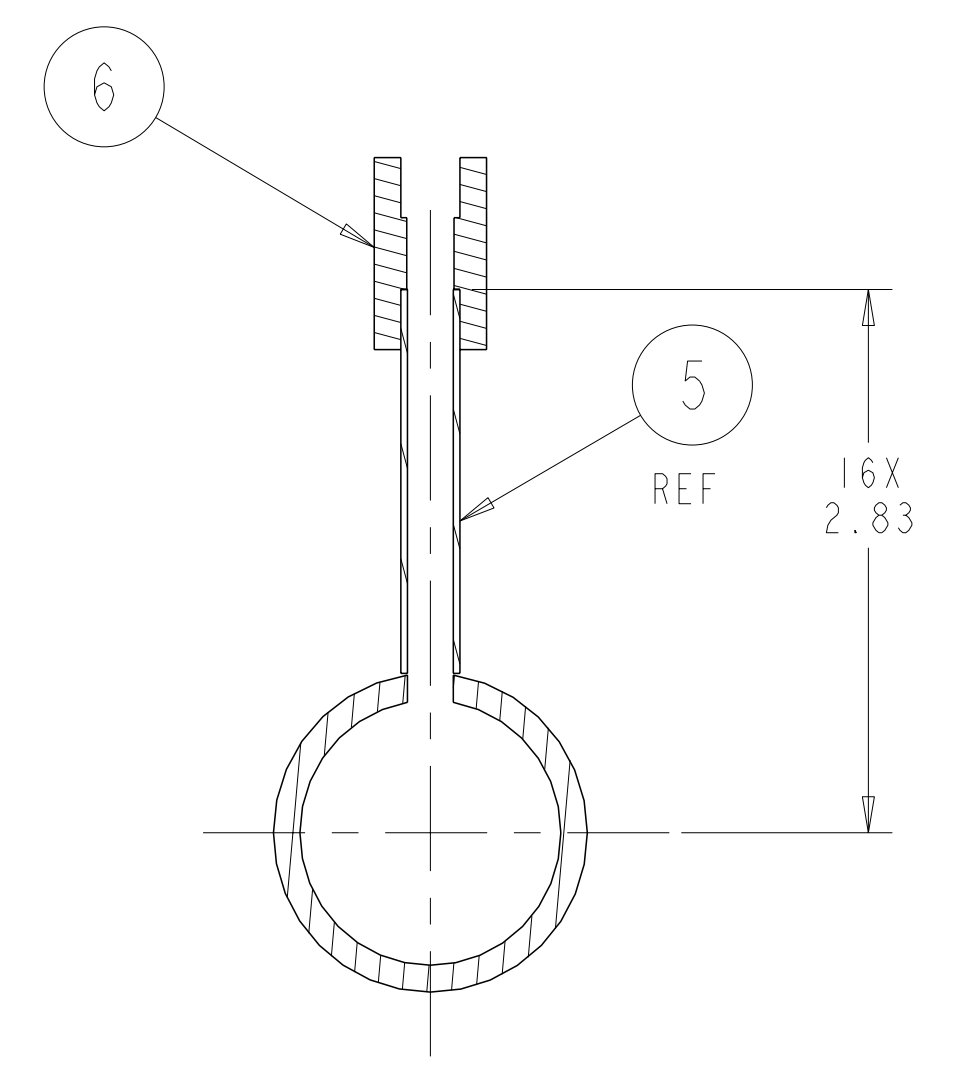

SECTION A-A
SCALE 1.00

WELDING ENGINEER
APPROVED _____ DATE: _____

AR	CAGE CODE	PART OR IDENTIFYING NO	NOMENCLATURE OR DESCRIPTION	MATERIAL	SPECIFICATION	FIND NO
AR	-7		WELD FILLER METAL			7
16	5 HW		SOCKET WELD TUBE UNION 5/16 X 5/16	316L	PARKER HANFIFIN CORP INSTRUMENTATION CONNECTIONS	6
16	-5		TUBE, 5/16 O.D. X .035 WALL	316L SST ANNEALED	ASTM A269	5
2	-4		BUTT WELD END CAP, 1 1/4 SCH 40	316L SST ANNEALED	ASTM A351	4
1	-3		BUTT WELD TEE, 1 1/4 SCH 40	316L SST ANNEALED	ASTM A351	3
AR	-2		PIPE, 1 1/4 SCH 40	316L SST ANNEALED	ASTM A312	2
AR	-1		INNER HEADER B WELDMENT			1

PARTS LIST

NO REPRESENTATION OR WARRANTY, EXPRESSED OR IMPLIED, IS MADE AS TO THE ACCURACY, COMPLETENESS OR USEFULNESS OF THE INFORMATION OR STATEMENTS CONTAINED IN THESE DRAWINGS, OR THAT THE USE OR DISCLOSURE OF ANY INFORMATION, APPARATUS, METHOD OR PROCESS DISCLOSED IN THESE DRAWINGS MAY NOT INFRINGE PRIVATE RIGHTS OF OTHERS. NO LIABILITY IS ASSUMED WITH RESPECT TO THE USE OF, OR FOR DAMAGES RESULTING FROM THE USE OF, ANY INFORMATION, APPARATUS, METHOD OR PROCESS DISCLOSED IN THESE DRAWINGS. DRAWINGS MADE AVAILABLE FOR INFORMATION TO BIDDERS ARE NOT TO BE USED FOR OTHER PURPOSES, AND ARE TO BE RETURNED UPON REQUEST OF THE FORWARDING CONTRACTOR.

P THIS DRAWING PRODUCED ON PRO-ENGINEER

SCALE: .50

REV	DESCRIPTION	BY	DATE	CHK	DEPT	DATE	PE	REQ	DATE	ORNL	DOE	DATE
0	ORIGINAL ISSUE											
	REVISION OR ISSUE PURPOSE											

SCALE	NOTED	DES	DATE
		P. L. GORANSON	04/07/05
		G. H. JONES	04/07/05
		S. PARSON	05/05

VERSION NO.	PLANT	BLOG	FL	SHT	OF	TYPE	CLASS
14	X10	5700	3	1	1	B	U
RELEASE LEVEL	SEI23-161						
WIP							