

- NOTES
1. DRAWING PREPARED IN ACCORDANCE WITH ASME Y14.100-2004.
 2. INTERPRET DIMENSIONS AND TOLERANCES PER ASME Y14.5M-1994.
 3. DIMENSIONS ARE IN INCHES
 4. MAGNETIC PERMEABILITY NOT TO EXCEED 1.02 AS TESTED BY A SEVERN INDICATOR. AVAILABLE FROM:
SEVERN ENGINEERING
AUBURN, ALABAMA 36830
WWW.SEVERNENGINEERING.COM

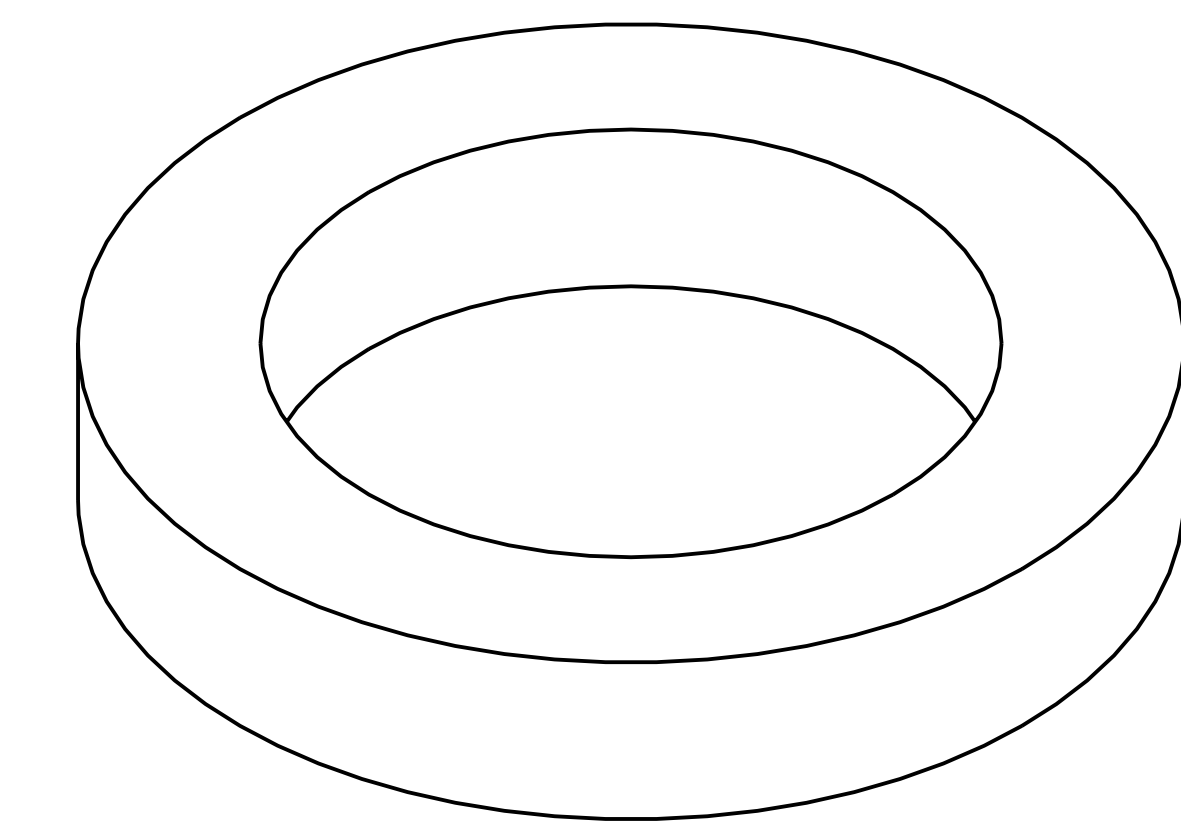

ISOMETRIC VIEW
SCALE 2.00

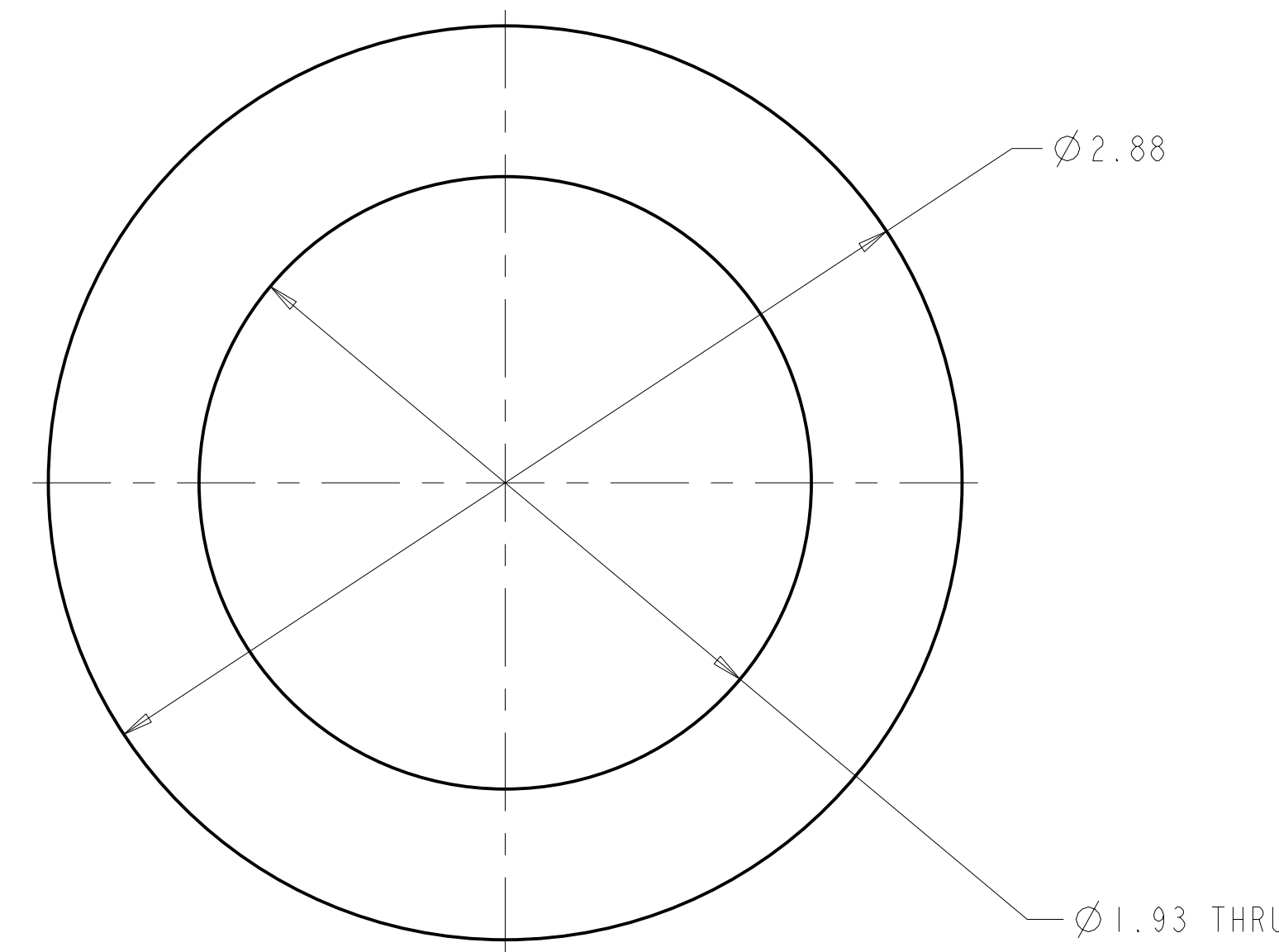

-1 WASHER
SCALE 2.000

**RELEASED FOR
FABRICATION / INSTALLATION**
PPPL Drafting:

AR	AR	AR	AR	CAGE CODE	PART OR IDENTIFYING NO	NOMENCLATURE OR DESCRIPTION	MATERIAL	SPECIFICATION	FIND NO
SE100-001	SE100-002	SE140-003	SE140-190		-1	WASHER	UNS R56400 Ti6Al4V	ASTM B265 GRADE 5	1
← NEXT ASSEMBLY						PARTS LIST			

NO REPRESENTATION OR WARRANTY, EXPRESSED OR IMPLIED, IS MADE AS TO THE ACCURACY, COMPLETENESS OR USEFULNESS OF THE INFORMATION OR STATEMENTS CONTAINED IN THESE DRAWINGS, OR THAT THE USE OR DISCLOSURE OF ANY INFORMATION, APPARATUS, METHOD OR PROCESS DISCLOSED IN THESE DRAWINGS MAY NOT INFRINGE PRIVATE RIGHTS OF OTHERS. NO LIABILITY IS ASSUMED WITH RESPECT TO THE USE OF, OR FOR DAMAGES RESULTING FROM THE USE OF, ANY INFORMATION, APPARATUS, METHOD OR PROCESS DISCLOSED IN THESE DRAWINGS. DRAWINGS MADE AVAILABLE FOR INFORMATION TO BIDDER ARE NOT TO BE USED FOR OTHER PURPOSES, AND ARE TO BE RETURNED UPON REQUEST OF THE FORWARDING CONTRACTOR.

P THIS DRAWING PRODUCED ON PRO-ENGINEER

DES: D WILLIAMSON 02/07		DRW: G MCGINNIS 02/07		CHK: M COLE 02/07		SECT: : :		DEPT: : :		PPPL DRFT J SIEGEL 02/07		VERSION NO. 0		PLANT ORNL		BLDG 5700		FL 3		SHT 1		OF 1		TYPE I		CLASS S		U	
TOLERANCES UNLESS OTHERWISE SPECIFIED		FRACTIONS ±.01		XX DECIMALS ±.005		XXX DECIMALS ±.0015		ANGLES ±0°15'		BREAK SHARP EDGES OR MAX		FINISH .125 UNLESS OTHERWISE SPECIFIED		DRAWING APPROVALS		DATE		RELEASE LEVEL WIP		SE140-193		REV 1							
REV		DESCRIPTION		BY		DATE		CHK		DEPT		DATE		PE		REQ		DATE		ORNL		DOE		DATE					
		1 REVISED MAT PER ECN-5232		DW		3/07		MC																					
		0 ORIGINAL ISSUE		GM		02/07																							

Oak Ridge National Laboratory
managed for the DEPARTMENT OF ENERGY under
U.S. GOVERNMENT contract DE-AC05-00OR22725
UT-BATTELLE, LLC. Oak Ridge, Tennessee
PROJECT NAME
NATIONAL COMPACT STELLARATOR EXPERIMENT

WASHER

SE140-193