

NCSX Cryostat and Cooling of Stellarator Core

Steve Raftopoulos
NCSX Cryostat WBS(171+623)

Introduction

The cryostat (WBS 171) is an insulating, semi-hermetic barrier that will allow the surrounding of the stellarator core with a cold nitrogen atmosphere down to a temperature of 77K.

The semi-hermetic nature of the cryostat excludes the components of atmosphere from approaching the stellarator core in the design temperature range (77K to 311K).

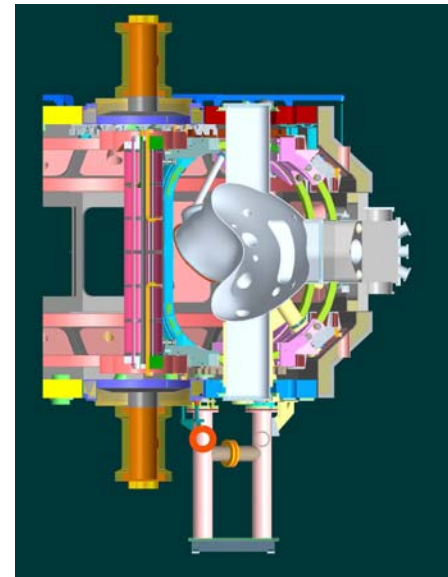
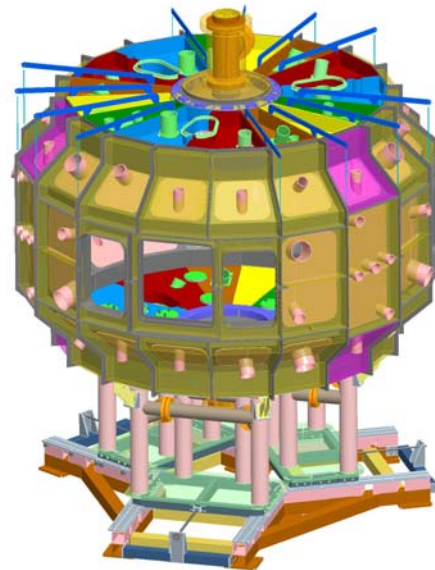

Requirements WBS 171 (cryostat)



- Must be gas-tight to internal positive pressure.
 - Small leaks are a nuisance, large leaks are expensive, very large leakage may risk ability to operate stellarator, in-leakage of air may damage components.
- Must provide penetrations for vessel extensions, electrical & hydraulic lines, stellarator supports, etc.
 - Shall be have provisions for custom configuration, i.e. future penetrations.
- Shall allow access to internal volume for stellarator maintenance
 - Demountable design
 - Removable panels.
- Shall withstand vacuum vessel displacements ($\sim 1/4$ " radial) due to thermal expansion/contraction.
- Shall withstand displacements ($\sim 1/4$ " radial) due to movement of the coil/coil support structure during magnet pulse and cooldown.
- The cryostat design, including penetrations and joint sealing, shall limit the influx of ambient heat to about 14 kW.
 - In order to limit LN2 usage to ~ 2 trailers per week.

Requirements WBS 171 (cryostat)



- Cryostat panels shall contain a feature allowing the admission of ambient temperature nitrogen gas.
 - Inhibits the oxygen enrichment of the panel system
 - Retards frost build up.
- Ability to relieve overpressure situation.
 - Pressure monitoring, LN2 isolation
- Shall be compatible with all identified ES&H requirements and best practices.

Interfaces

- **MECHANICAL**
 - EVERYTHING is either within or passes through the cryostat. A system interface document will address all interfaces, including planned (and unplanned) maintenance.
- **ELECTRICAL**
 - Coil buss work
 - Signal and control cabling
- **ENVIRONMENTAL/SAFETY**
 - Test cell (maintain environment safe for occupation)
 - Oxygen deficiency in Test Cell and Test Cell Basement must be addressed
 - Oxygen enrichment must be avoided.
 - HVAC (nitrogen gas must be vented outside via ducting).

Cryostat Design

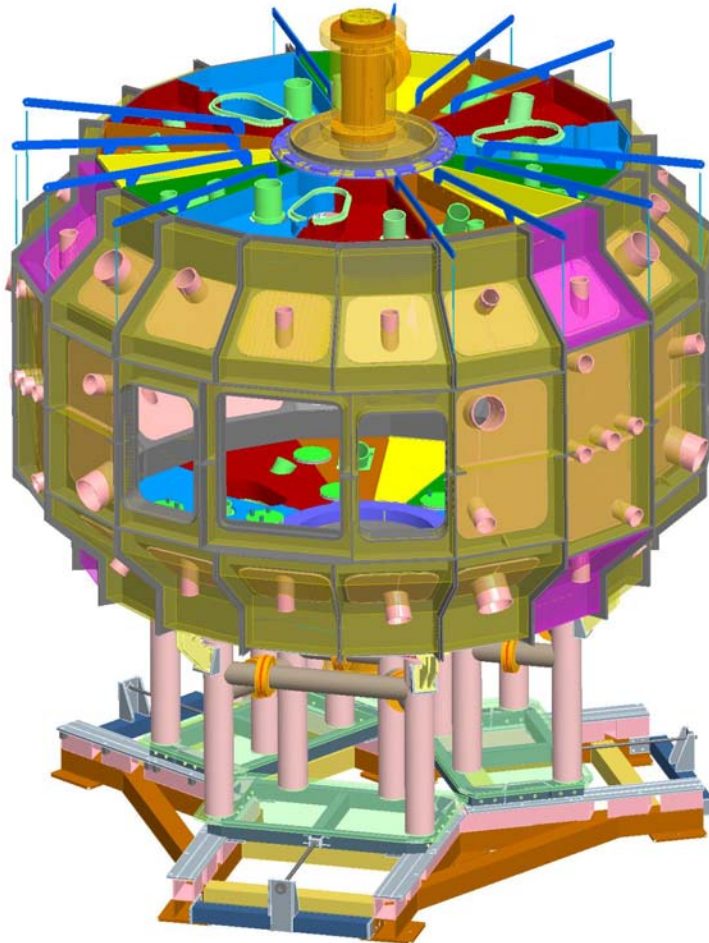

- It arrives at the Test Cell in finished sub assemblies
- Keeping with the modular concept, the cryostat is an array of panels edge-bolted together.
- The tubs have gas seals at their joining edges
- An alternative is to “foam-in-place” for the gaps between panels.

Cryostat Panel

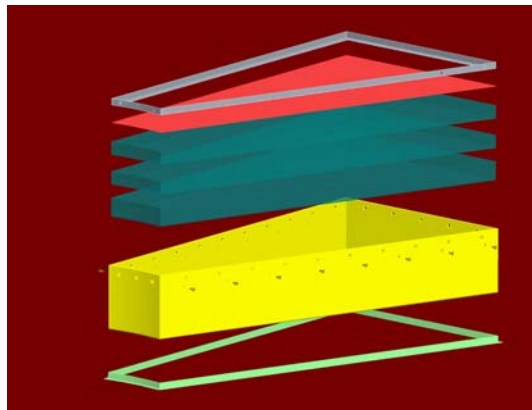
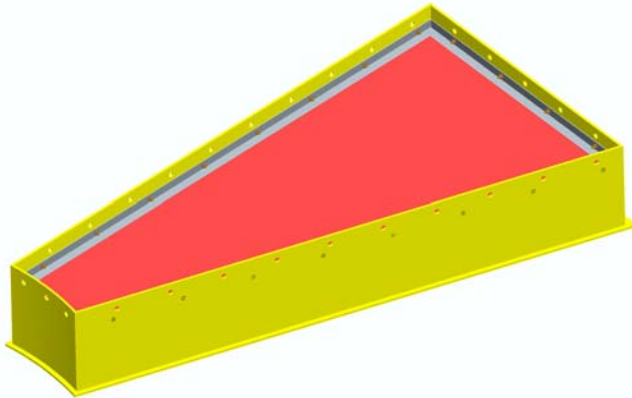

- The simple yellow panel is shown here with its cover in place.
- The cover, properly installed, results in leak-tight (1-in Water, bubble check) module.
- The module will be provided with a purge fitting for low press N2 gas to keep moisture out.
- The panel is loaded with 17 cm of closed cell polyisocyanurate board stock in layers. Any joints in the layers are staggered by several inches.
- The green 2 x 1 cm unequal leg angle is bonded in place to serve as a seal limiter for the inter-panel packing.
- The flat-head screws for the cover are insulating material (for accidental drops).

Panel seal system

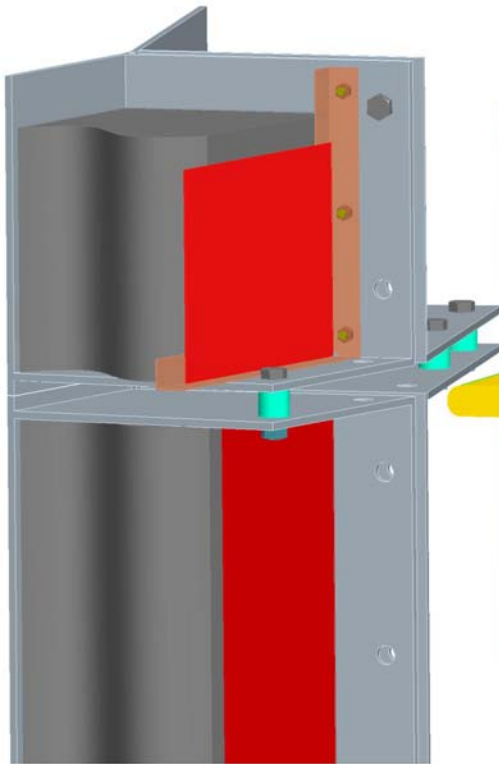

Intersection of 4 panels.

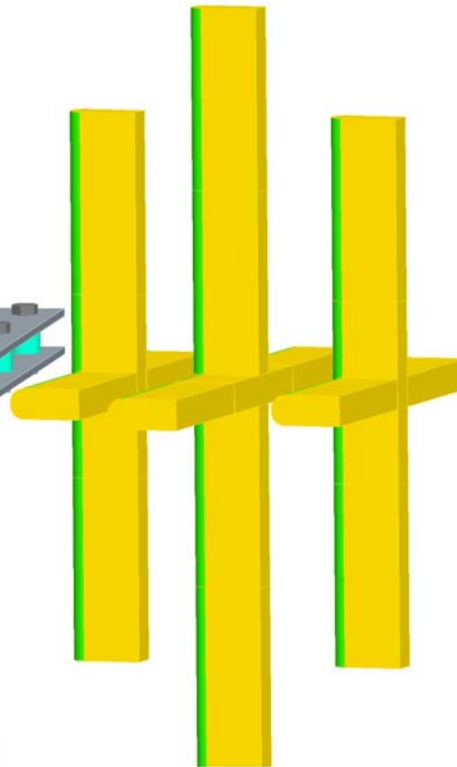

**Foam seal system
(solomide + kapton)**

- Adjacent panels are joined with screw-bushing-nylok nut combinations.
- The bushings will be of insulating materials in case of accidental drop-in.
- This method of joining the warm edges of the panels together with a controlled gap between adjacent seal limiters will tolerate dimensional change in the cryostat during cool-down and warm-up cycles.
- Layers of over-thick resilient foam with PTFE tape on the edges serve as the packing for joints and for MOST penetrations
- Multiple PTFE (or kapton) membranes end reliance on a single inboard seal
- This scheme is fully serviceable from the outside of the cryostat.
- A final circular bead (not shown) seals the joint from atmosphere

Thermal Characteristics of Candidate Materials



Material	Thermal Conductivity	Coeff of Thermal Expansion
Dow Trymer 2000 Closed Cell Foam	0.027 W/mK @ 293K	9e-5 /K @ 300K Unknown @ 77K
Inspec Solimide Open Cell Foam	0.040 @ 293K	Resilient at all temperatures of interest
G-10 Warp Direction (Inconel 718 is similar)	0.85 W/mK @ 300K 0.30 W/mK @77K	1.16e-5 /K @ 300K 5.5e-6 /K @ 77K
Teflon	0.26 W/mK @ 300K 0.23 W/mK @77K	4.2e-5 /K @ 300K 3.4e-5 /K @ 77K
304 SS	14.9 W/mK @ 300K 8.2 W/mK @77K	1.6e-5 /K @ 300K 7.5e-6 /K @ 77K

Partial Parasitic Heat Load



- The 0.027 W/mK associated with the candidate closed cell foam suggest a constant heat load of about 5 kW through the panels only.
- 5 kW suggests the vaporization of
 - 4900 gallons of LN2 or
 - $\frac{3}{4}$ trailers per week
- The GRD offers a non-bakeout parasitic load of 2.12 trailers per week
 - The panels claim 36% of this number

Differential Thermal Expansion

	R = 152 cm Vertical Port	R = 193 cm Outboard Leg	R = 320 cm Midpland Diag Cover
Cryostat, G-10 300K to 80K	-0.35cm	-0.44 cm	-0.74 cm
Vessel and Graded Extensions, Inconel 300K to 650K	0.65 cm		~0.8 cm (assuming some gradients in ports & ext.)
Machine Base, 300 Series SS 300K to 80K		-0.56cm	

Differential expansion between the vessel and the penetrations is not trivial at 1 cm & 1.5 cm!

The cold inboard seal must tolerate this displacement AND this assumes no asymmetric vessel constraints (NB tugging vs. diags)

Design considerations

- Pros
 - Modular panel design, allows access to stellarator as required.
 - Rigid panelized system, fabricated in relatively small sections that are easy to transport and handle.
 - Readily repairable in-situ if damaged.
 - Preliminary mechanical and thermal analysis has been done.
- Cons
 - Incorporates many linear feet of seals.
 - Unproven sealing technique – needs prototyping/proof of principle (or validation by cryo experts)
 - Panelized base of cryostat may not contain LN2 if gas condenses and accumulates as liquid.

Special area of concern

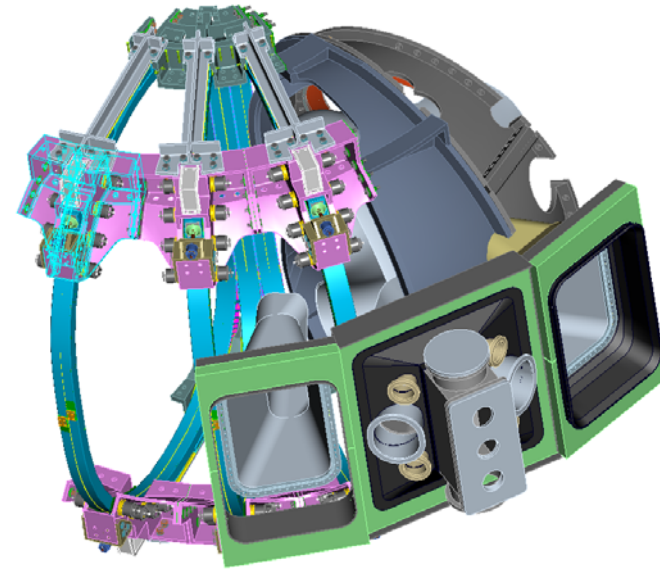
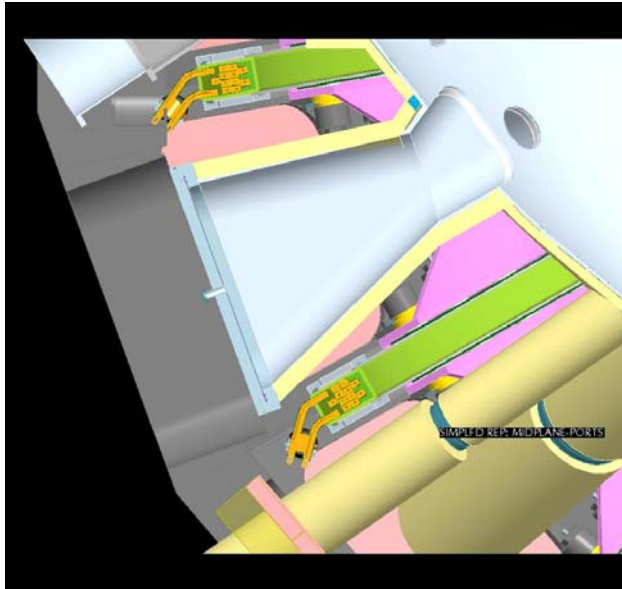

- The large VV ports intersect the volume space otherwise allocated for the cryostat. Cannot install the desired thickness of insulation.
- NB and large port seals need further development.
- We could consider a vacuum-jacketed solution in these areas.

Design Alternatives

- A simpler cryostat (like the Alcator C-Mod), that uses a upper/lower “dome” and minimally segmented cylinder.
- One derivative of this approach would be to increase the diameter to allow access for an individual to maneuver within the cryostat
 - Pros
 - More easily sealable, reliable
 - Lower, one-piece dome would contain liquid.
 - Cons
 - Loose a large degree of accessibility
 - Adds length to the port tubes used by diagnostics (reduced aperture)
- Instead of pliable foam seal, we could “foam-in” the joints and cut them out when access is needed.

Penetration Sealing Schematic

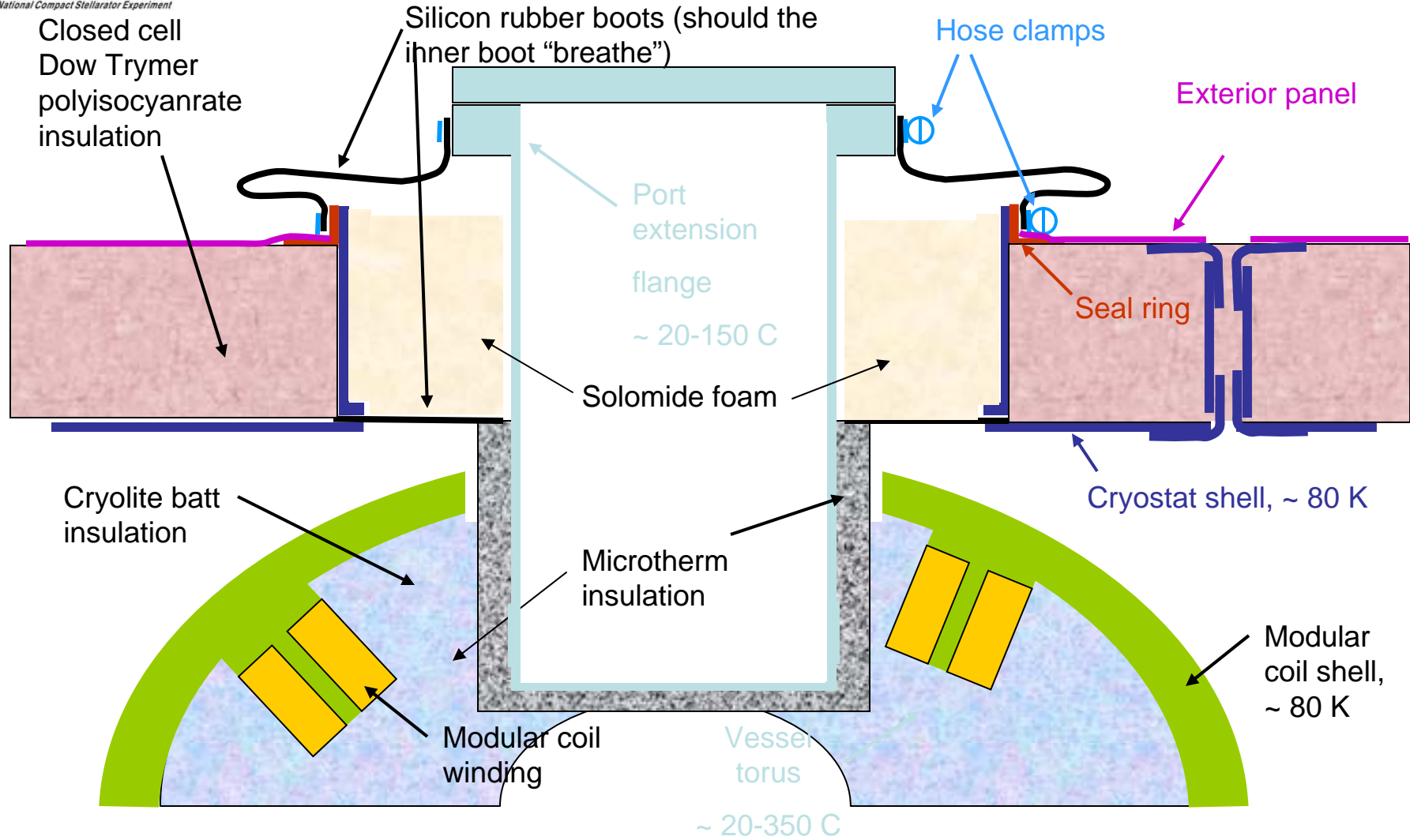

Penetration Basics

- Inner boot is historically fiberglass cloth impregnated with Dow silicone compound
- The penetrations be entirely serviceable from the exterior of the machine
 - Our ever-growing concern about confined spaces AND time-for-rescue tends to call for exterior serviceability
- Inboard travel limiter to prevent packed joint seals from falling in
 - Limiter included in basic tub would be expensive
 - A value-minded engineer might glue non-conductive angle on the tub

Penetration (bag) sealing prototypes

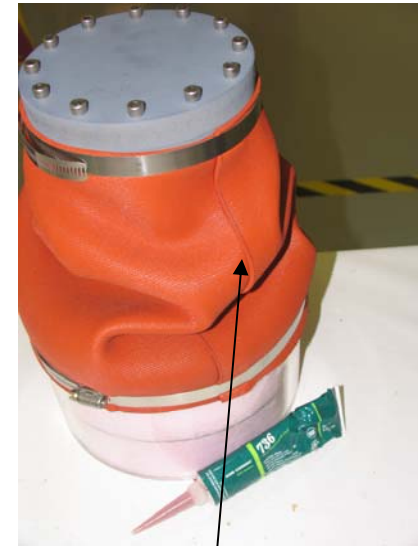
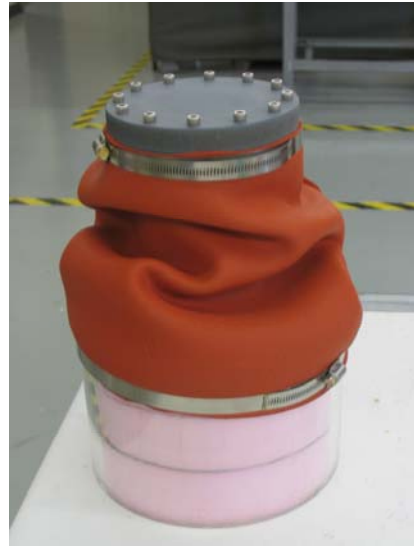

seam glued with dow
corning RTV 736

Diagnostic Ports

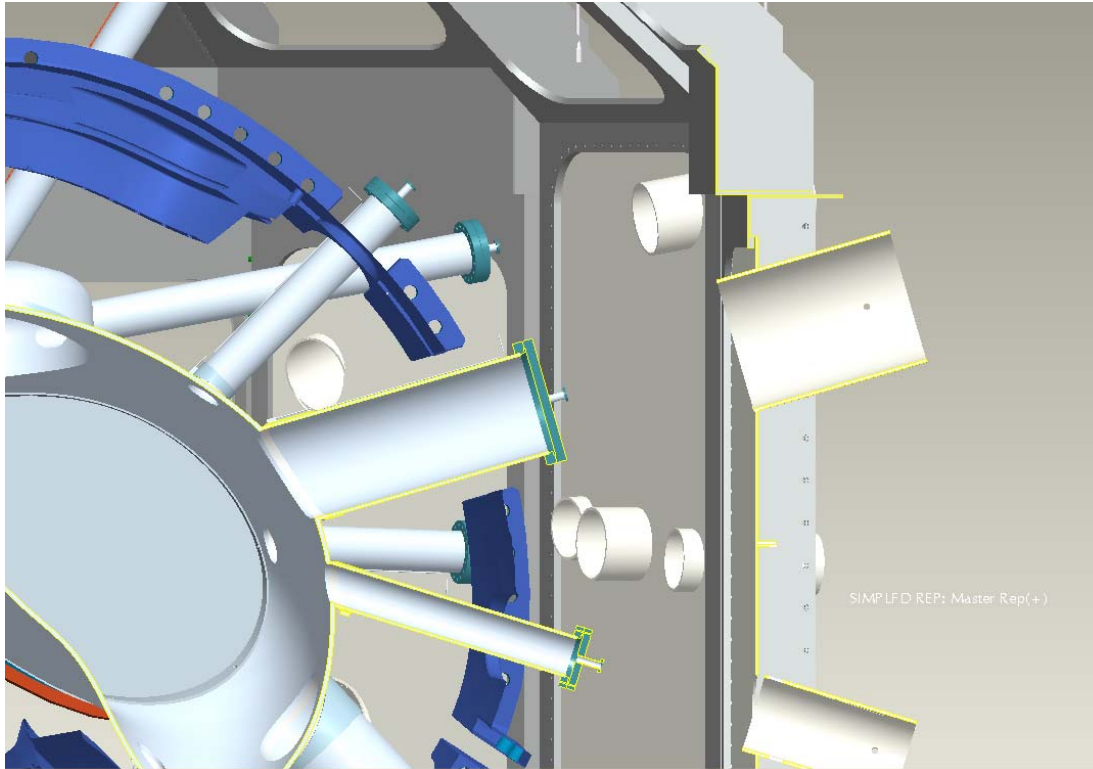

- **Diagnostic ports penetrate at varying angles, trapping the cryostat panel.**

- **Diameter of cryostat port will have to be large enough to allow workers to access flange**

Cooling the Contents of the Cryostat

Cooling the Contents of the Cryostat - Requirements



- Cool the stellarator in 96 hours (soft requirement)
- Cool stellarator without introducing thermal stresses or compromising dimensional control. Limit ΔT to 50K
- Cool the coils at the same rate as the surrounding environment.
 - May need to control the flow of cold fluid through conductors' cooling channels to ensure this is met.
- GRD also asks for the ability to warm the coils to room temperature in 96 hours

Concerns

- Stratification of GN2 temperatures may result in uneven cooling of the structures.
- Cool down and warm up of system in a reasonable timeframe and without creating temperature variations.
- Cooling the coils and the structure at the same rate.
- Using LN2 for cooling may result in accumulation/condensation of liquid at bottom of cryostat. This may cause sealing issues resulting in LN2 and cold gas leaks.

Cooling the Contents of the Cryostat - Considerations



- The Modular, Poloidal Field and Toroidal Field coils (total weight ~50,000 lb) are actively cooled via cooling channels either within or bonded to the magnet.
- The rest of the structure (~100,000 lbs in modular coil shell, and 100,000 lbs widely distributed mass) must be cooled via secondary system.
- The interface between the modular coil pack and the winding form (shell) was designed to be thermally decoupled, so conduction from the 18,000 lbs of cooled copper and 100,000 lbs of stellaloy (300 series SS derivative) is limited.
- Coil Test Facility's cryostat showed that without any mechanism to actively "mix" the cold gas, temperature stratification will result – we should expect the same result for the stellarator cryostat.
- Temperature stratification may result in temperature gradients between or across structural components and magnets. This could result in mechanical stresses and/or displacements of coil centroids which are painstakingly fabricated and positioned with very precise dimensional control. **Analysis is needed here to identify limits.**
- We are considering the used of ducted cold gas, internal mixing fans, multiple LN2 spray heads as a means to minimize stratification.

SIMPLIFIED GN2 CRYOSTAT COOLING SUPPLY

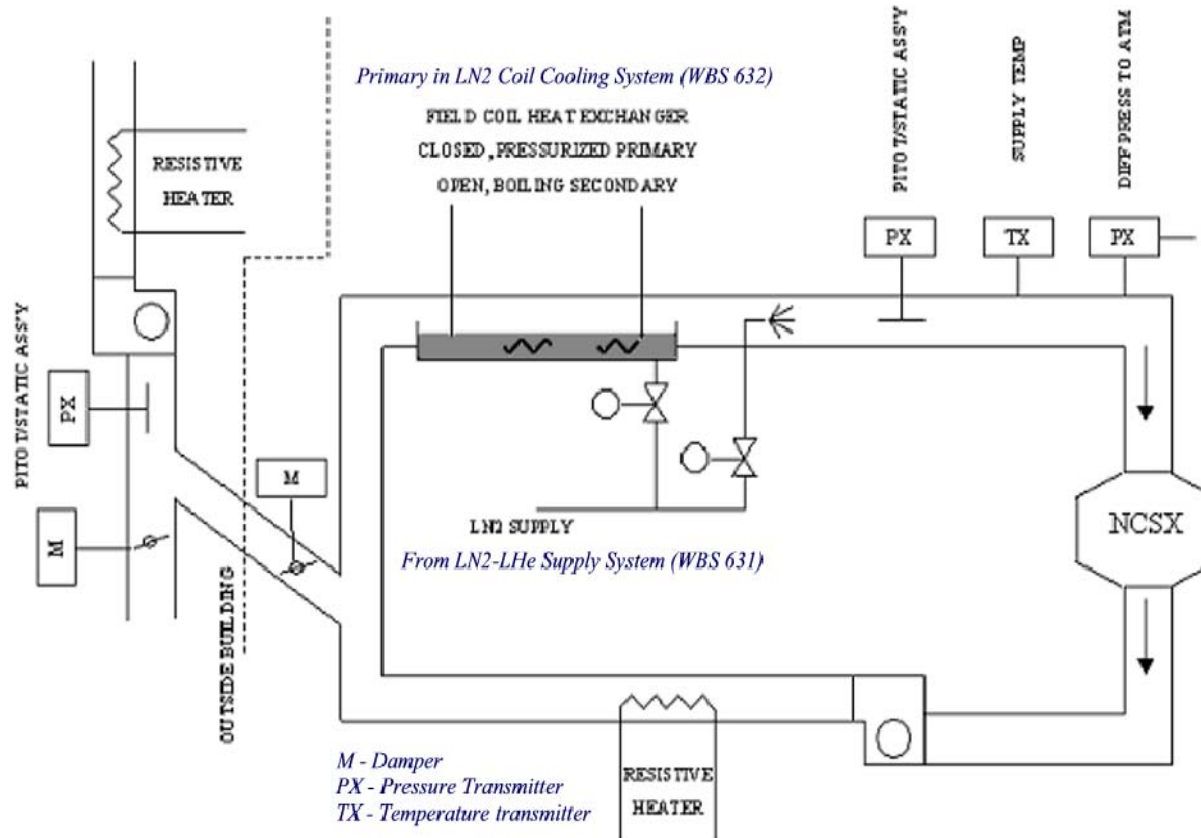

The actual cryostat attachment points for the insulated supply and return ducts have not yet been selected. Top and bottom center are favored to promote a flow pattern having radial symmetry. Dominant loads are heat leakage from bakeout and from port extension penetrations. The cryostat's nitrogen pressure will be kept slightly positive relative to the atmosphere.

Stellarator Cool Down Process

- Introduce temperature-controlled N₂ gas into the coil cooling passages and into the cryostat.
- Using thermocouple data, drive the temperature of coils and structures down in steps at approximately 2 degree/hour (average).
- When the system is sufficiently cold (this was done @ 130K for the C1 cold testing), introduce LN₂ into coil coolant passages.

Possibilities??

- We could spray LN2 directly onto structures that are shielded from convective cooling.
- Fans for mixing operating within the cryostat.
- Conduction cooling via plates or tubing? (Alcator C-MOD recommendation).
 - May be feasible for the modular coil mass, but the 100,000 lbs of distributed mass will be difficult to cool this way