

NCSX Autoclave PDR

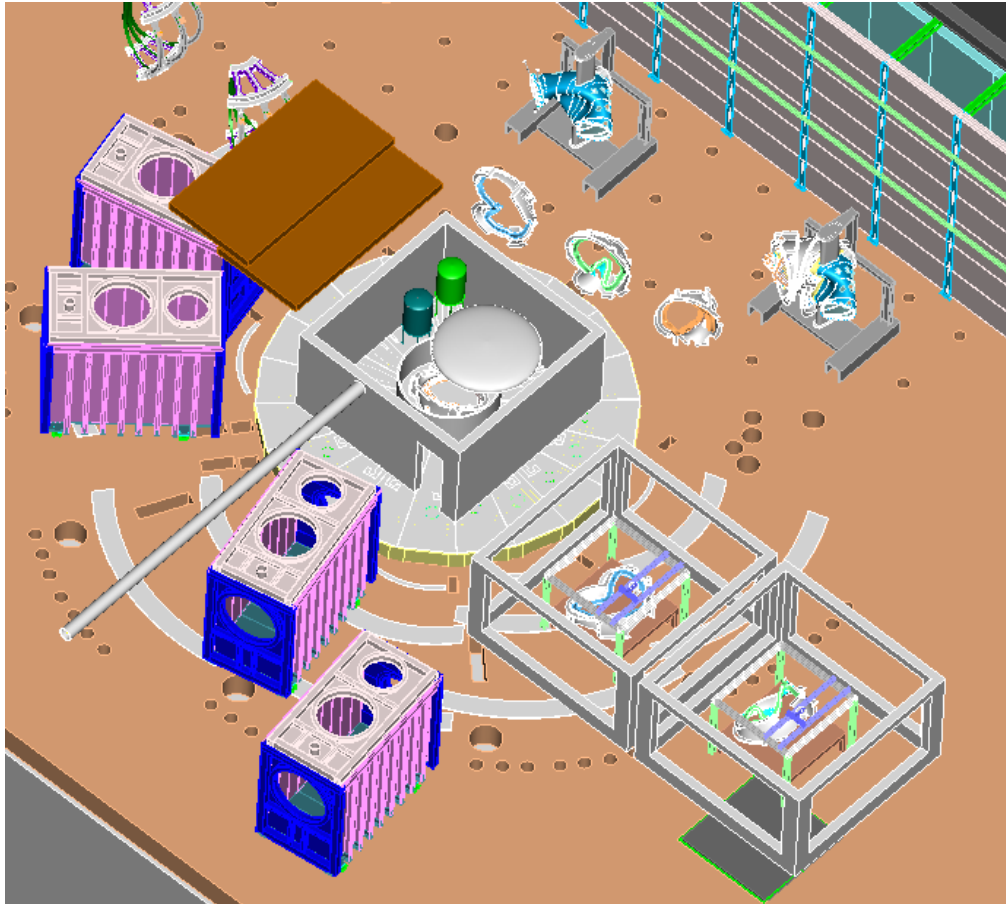

Steve Raftopoulos

Frank Jones

1/8/03

Scope

- This review covers the mechanical and electrical design of an autoclave chamber that will be used for the epoxy impregnation/curing of the NCSX Modular coils.

Agenda

- Intro & Background
- Requirements
- Design/Drawings
- Analysis (preliminary calculations)
- Test requirements & Plans
- Review of Peer Review Chits
- Manufacturability
- Electrical Presentation (F. Jones)
- Cost/Schedule

Background

For epoxy impregnation, typically a sealed case is built around the coil. Vacuum is pulled on the case, enabling the epoxy to flow into the winding and very effectively fill voids.

The shape of the NCSX modular coil makes it impractical to build a rigid metal case, therefore a fiberglass case will be hand formed around the twisting geometry.

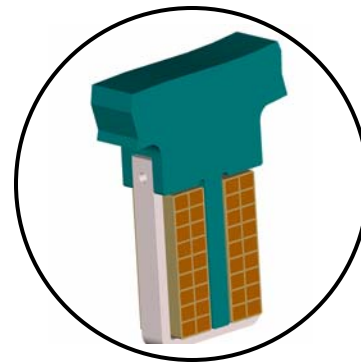
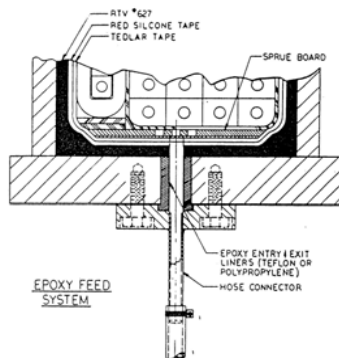
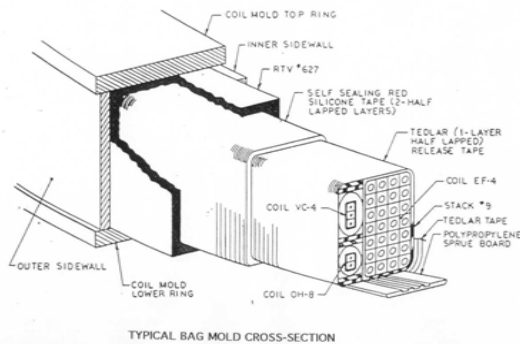

Coil X-section

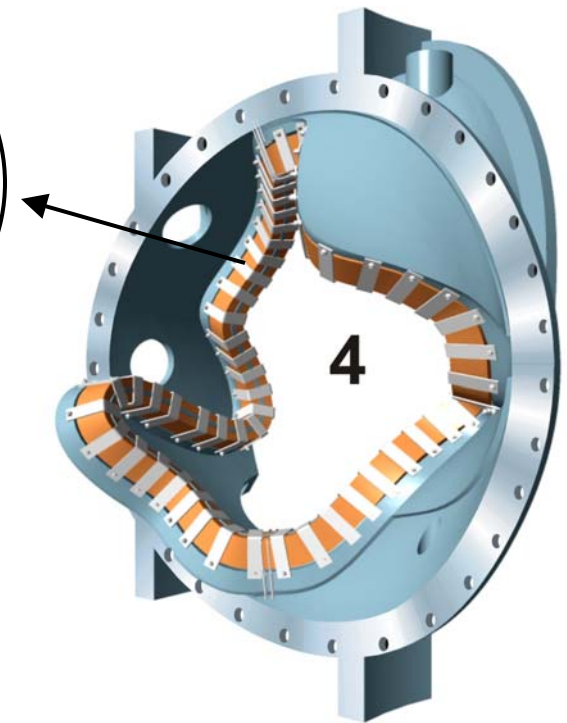

Background (cont.)

Since this case is substantially weaker than a metal case, a vacuum will be pulled on both sides, minimizing the stress from differential pressure.

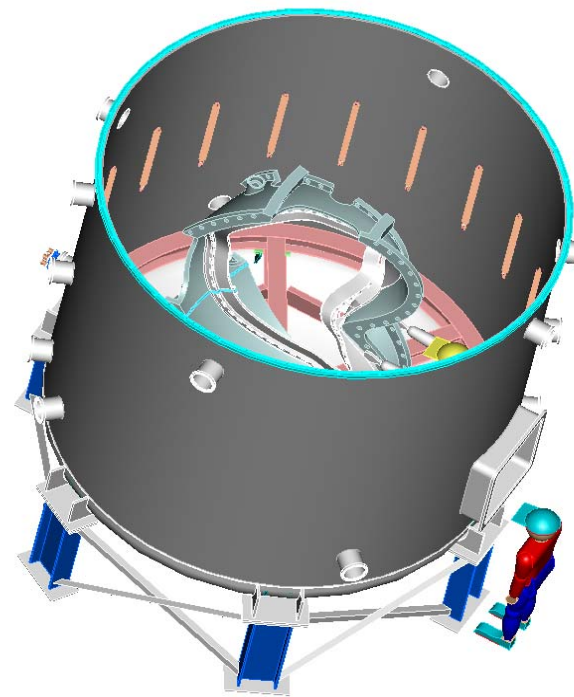

SIMPLFD REP

Major Design Requirements

- Large enough to accommodate the NCSX modular coil sections.
- Can achieve and maintain a base vacuum of 1 torr in ~ four hours.
- Can heat coil sections to 130 degrees centigrade.
- Can accommodate a positive pressure of 15 psig.
- Provide ports for:
 - Epoxy feedthroughs
 - Thermocouple feedthroughs
 - Viewports
 - Man entry

Design

- Dimensions - 5/8" thick, 14' dia x 11" tall tube.
- ASME dome heads (std catalog item).
- 304SS vacuum chamber.
- Support stand

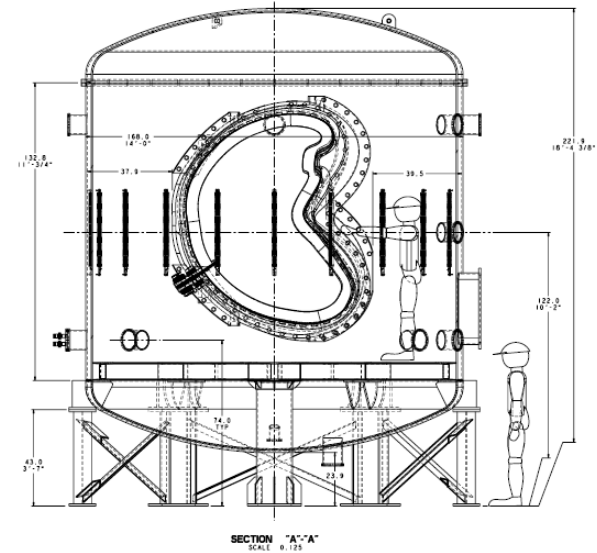
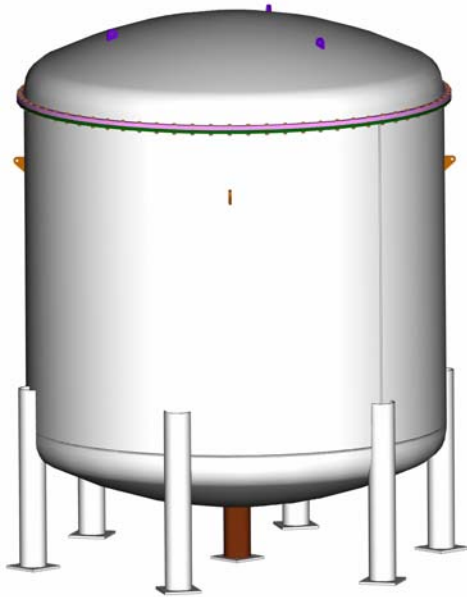
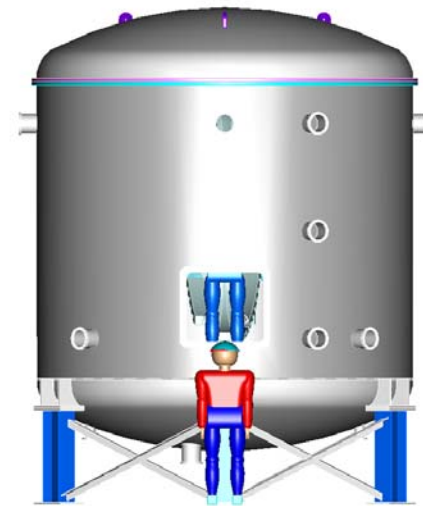

Design (cont.)

- Floor at bottom of tank capable of supporting the modular coil (8 k#).
- Platforms, external and internal to facilitate epoxy tanks, personnel ingress/egress, access to attachment of thermocouples and epoxy sprus.
- 60-70 kilowatt resistive heating
- Circulating air as heating fluid

LOWER DOME

PLATFORM & VESSEL SUPPORT STRUCTURE

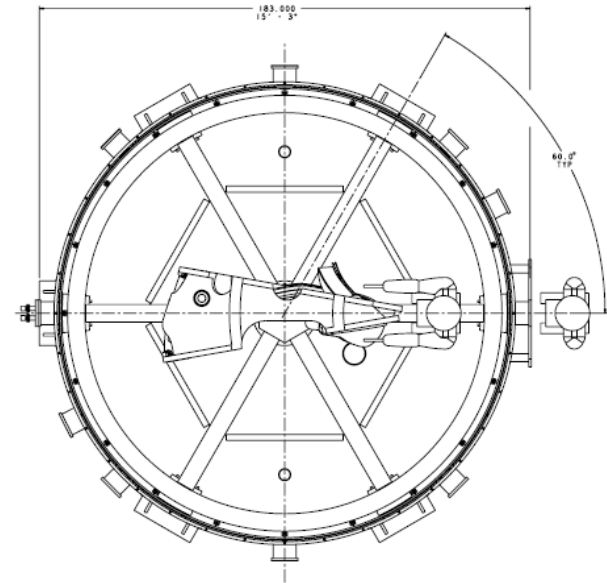
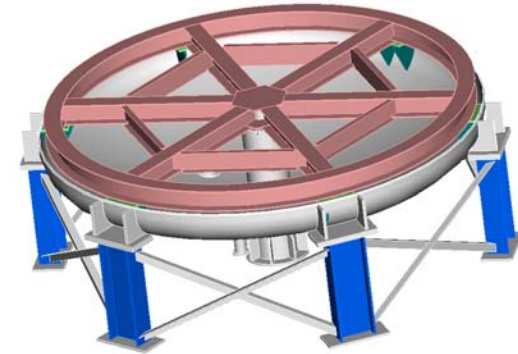

Design (cont.)

- Circulating, heated air will provide the heating.
- Resistive heating elements, bolted to tank surface and in the air-stream will heat the air and maintain temps during vacuum operation
- Thermocouple readings shall provide feedback control of the heater power and/or airflow.

Design (cont.)

- Ports:
 - Two, 16.5-inch diameter ports for epoxy feedthroughs, each containing 19 sprus, will be available. One port just above midplane and one port at top of cylinder.
 - One, 16.5-inch diameter port that contains multiple, smaller (2.75”) thermocouple feedthroughs.
 - Two, eight inch ports for the circulating heated air. Inlet port located in the lower dome, while the return port is located at the top of the cylinder.
 - One 10-inch diameter port that contains electrical feedthrough(s) for internal lighting.

Design (cont.)

- Ports

- Four racetrack-shaped or six 8-inch dia. round viewports for inspection, located to provide full viewing coverage of the spru attachment points to coil.

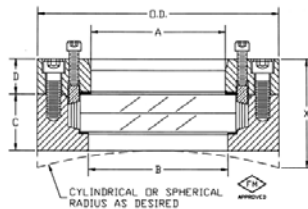
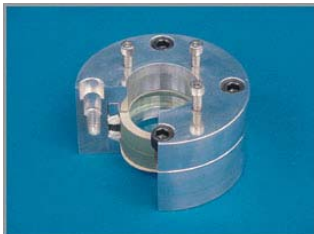
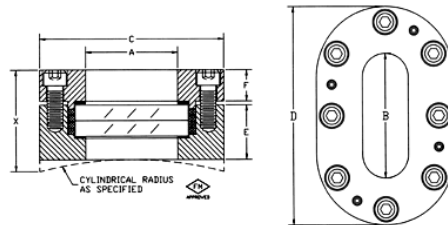

- Ports

- One 32-inch man-way, with T-bolt, hinged closure.



Design (cont.)

- Heating system
 - Heating system consists of 36, 2kwatt electric resistive heaters, mounted to the outside surface of the tank.
 - Additionally, 10 kwatt of resistive heating shall be available within the air circulating piping to provide heated air for vent up from vacuum at 50 degree centigrade.
 - Elements can be turned on in banks, allowing variable heating rates tailored to accommodate the modes of operation.
 - Circulating air will improve heat transfer (convection oven effect)
 - Air is introduced at lower dome and is diffused by the perforated floor.

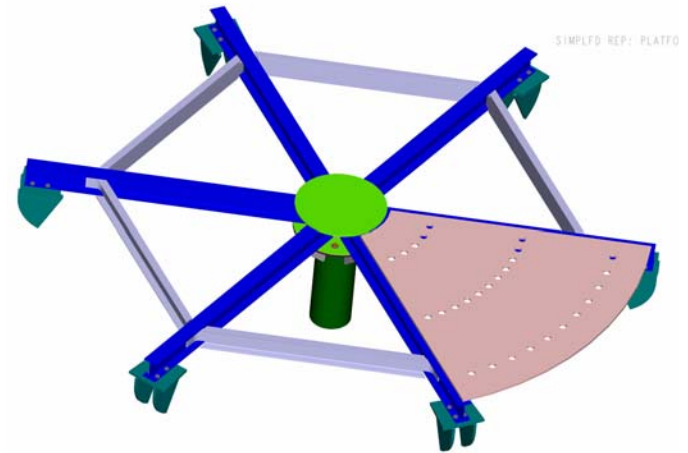

Operating modes

- In Air @ STP, heat entire mass from room temp. to 45 Deg C.
- Pull vacuum, maintain 45 C and impregnate coil.
- Vent with air to STP and raise temperature (slowly) from 45 to 110 C.
- Hold at 110 C for 5 hours
- Raise temperature to 125 C and hold for 16 hours
- Turn off heating system and allow to cool naturally.

Manufacturing Requirements

- 304 SS chamber.
- Magnetic permeability not important.
- O-ring seals.
- Man-entry door for access when lid is in place.
- Internal lighting.
- Viewports for inspection during impregnation phase.

Operational Requirements

- Achieve vacuum <1 torr in 4 hours.
- Room temp to 45 C in 4 hours.
- 45 C to 110 C in 15 hours.
- Temperature monitoring and feedback control of heating.

Analysis (preliminary calculations)

- Calculations have been performed for the following:
 - Mechanical loads
 - Hoop stresses are very low.
 - Have FS of ~5 for buckling critical pressure.
 - Thermal
 - Tank and components will require ~ 50 kW to heat in desired time frame. This considers heat loss from convection and conduction (very minor). 1.5 inch of thermal insulation will be installed onto tank.
 - Vacuum
 - One 50cfm pump should be able to pump down the chamber to ~1 torr in 4-5 hours. Recommend that we have 2 pumps available.
 - **These calculations will be formally checked and approved prior the FDR.**

Peer Review Chits

- Avoid overly complicated weld details.
 - Working with shop in developing details
- Save cost by welding legs directly to the tank.
 - Detail changed
- Consider using less expensive ANSI flanges for feedthrough connections.
 - Will review on case by case basis, need some vacuum flanges.
- Protect pumps from VPI Process
 - Effluents will be cryo-trapped before getting to pump.
- Remove ring girder for floor.
 - Removed.
- Keep man access door away from facing south. NB Boxes (tritium source)
 - Will orient door away from NB boxes.
- Consider vendor fabrication of tank, including flanges.
 - This is the default plan.
- Consider removing the circulating system and have an internal fan.
 - Need a heated section of pipe for warm air introduction.

ES&H concerns

- The project is committed to the use of engineering and administrative controls to eliminate and/or minimize hazards to workers and the environments
- Environmental
 - We'll be pumping the off-gassing from the epoxy (Hysol or equivalent) through the vacuum pumps and into the test cell. We will cold-trap these vapors.
- Safety/IH
 - The autoclave chamber will be a confined space. Hazards include:
 - Oxygen deficiency
 - Electrical
 - Hot surfaces
 - Lifting/rigging
 - Elevated workspace
 - Vacuum hazards
- These are hazards that have been successfully dealt with

Manufacturability (buy vs. build)

- We plan to have the tank fabricated at outside vendor. The ports/flanges will be fabricated at PPPL.
 - We will furnish procurement with a set of approved drawings for the basic tank within the next 2 weeks.
- We plan to purchase (or locate on-site) all other components that integrate into the system.
- We see no major procurement issues at this time. All components are standard catalog items. Even tank domes are std. ASME design.

Testing Requirements & Plans

- Manufacturing:
 - Weld inspections
 - Conformity to print
- Operational:
 - Vacuum leak check
 - Heating system check
 - Vacuum pump check
- PTP:
 - Perform dry run (to operating temperature) with empty chamber
- Impregnation tests:
 - Impregnate the curved T-section test castings
 - Impregnate the prototype modular coil

Primary Goals (Electrical)

- Develop a portable low cost power system.
- Provide adequate 480v power for heater and vacuum pumps.
- Provide 208/120v power for secondary systems, control systems and general use.
- Develop a flexible control system.
- Incorporate personnel safety into operations.

Heater Layout

Mount all heaters in pairs on exterior of tank in 3 rings. The top and bottom rings are primary heaters consisting of 24-2000w strips. The center ring has 12- 2000w strips for secondary heat.

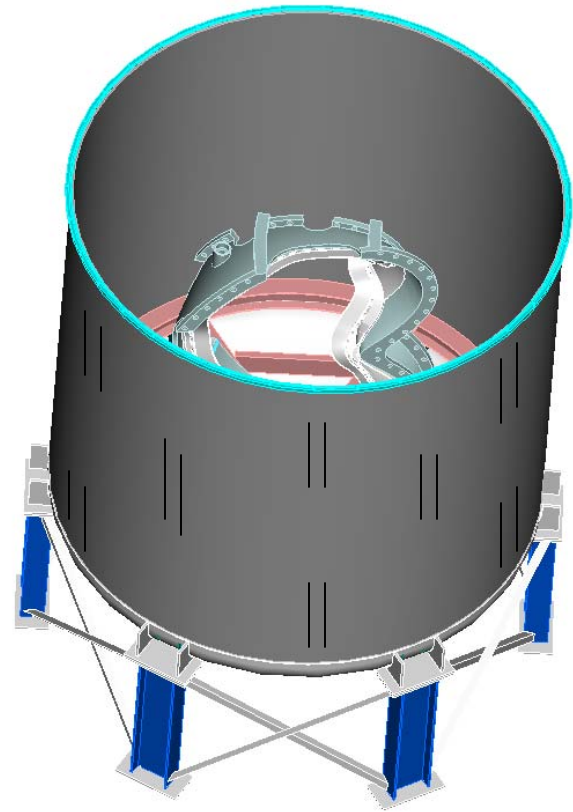

AC Power Schematic

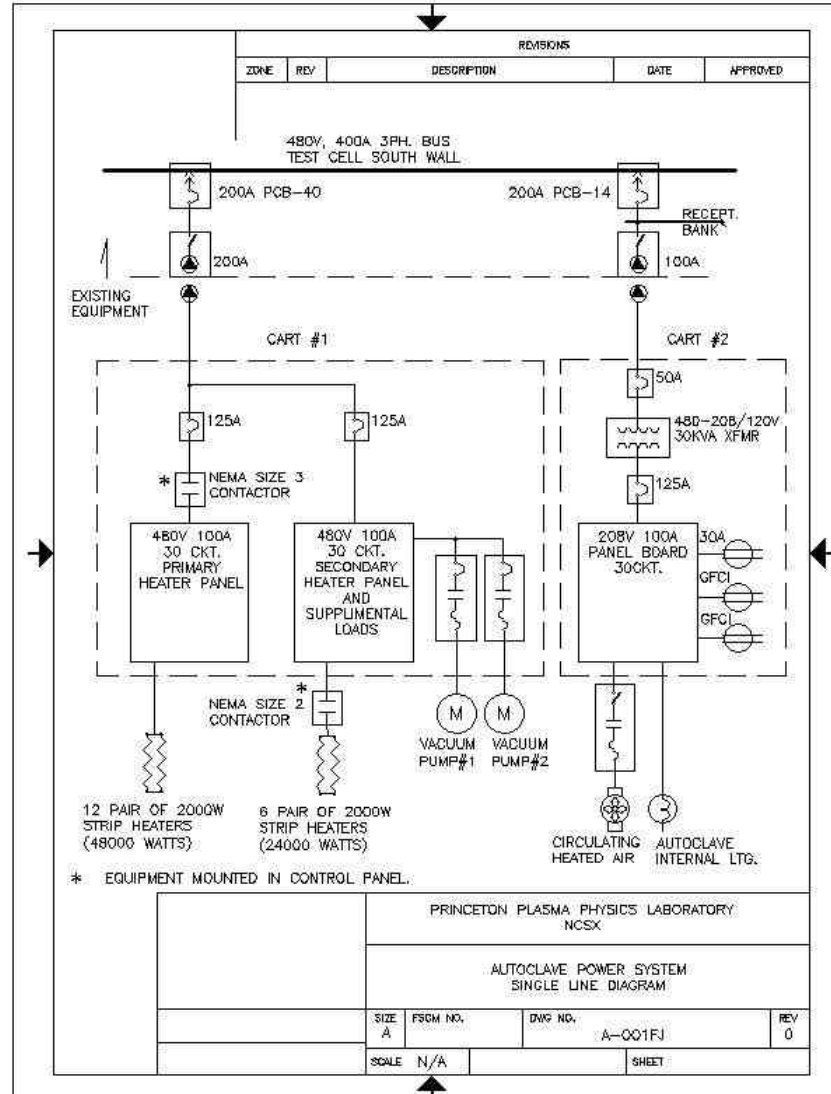

Electrical Power/Controls/Instrumentation

- Power Requirements

- Heating Elements (Approx. 75 KW total)
- Lighting
- Heated Air and Circulation Fan
- Vacuum Systems

All of the above can easily be supplied from two 480v, 3 phase feeders readily available in the Test Cell (1- 200A receipt. And 1- 100A receipt.)

- Control

Contactors will be used for on/off control of Heaters, Fan and Vacuum pumps in order to allow the possibility of future upgrade to automatic control (PC or PC/PLC based). Initial design will employ Thermocouple Controllers (with manual override) to maintain oven temperature.

- Safety

- All heaters and vacuum pumps can be locked out/isolated when personnel access the autoclave.
- Autoclave shell temperature will be monitored.

Electrical Power/Controls/Instrumentation

- Instrumentation

- Internal and external thermocouples will be wired to a Patch Panel so as to provide flexibility in choice of which thermocouples to monitor and which to use as control thermocouples during oven operation.
- Vacuum/Pressure will be monitored

- Wiring/Layout

- All internal connections to autoclave internals will be made through electrical vacuum feedthroughs
- External wiring and equipment layout will be designed such that the autoclave may be relocated in the future with minimal re-wiring.

Costs

- Major M&S expenditures

– Vacuum chamber	\$30,000
– Viewports	\$2000
– Man-way	\$1500
– TC feedthroughs	free
– Pumps	free
– Piping	\$2,000
– Valves	\$2,000
– Insulation	\$3,000
– Epoxy feedthrough ports	free
– Heating elements	\$6,000
– Structural steel	\$5,000
– Electrical M&S	\$15,000

Costs

- Shop Labor estimates (mechanical & electrical)

– Vacuum chamber machining	20 man-days	SM
– Ports (fab/weld/install)	20 man-days	SM
– Chamber legs/floor	15 man-days	SM
– Install heating elements	15 man-days	TB
– Chamber setup in TC	10 man-days	TB
– Vacuum piping fab	5 man-days	SM
– Vacuum system setup	5 man-days	TB
– Chamber setup in TC	10 man-days	TB
– Insulation	5 man-days	TB
– Platforms	10 man-days	TB
– Misc. Shop	15 man-days	TB
– Electrical Shop	40 man-days	TB
– Electrical Field	26 man-days	TB
- Totals
 - 60 M-days SM, 56 M-days in budget
 - 136 M-days TB, 100 M-days in budget

Schedule

- Drafting/design Nov. 25
- Peer Review 12/9/02
- PDR 1/8/03, today
- RFQ Tank & lids Jan
- Place tank/lids order early Feb
- Fab stand and ports Feb-March
- Receive Tank/Lids April 1
- Mod Tank/Lids April/May
- Ready for leak check June 1
- Transfer to Test Cell June 5
- Connect to services July 1
- Shakedown/PTP July
- Ready to go August 1

TBD by FDR

- Review/approve specification
- FMEA
- Complete detail drawings
- Check/approve calculations
- Tentative date 1/31/03