

Table of Contents

STARTING A V-STARS PROJECT	1
New Project.....	1
OPENING AN EXISTING V-STARS PROJECT	4
Open Project.....	4
TEMPLATE PROJECTS	6
Introduction.....	6
Creating a New Template Project.....	6
Opening a Template Project.....	7
Destination folder	8
IMPORTING FILES	9
Import Images.....	9
Setting the Image Path	9
Default	9
Manually Setting the Image Path	9
Picture from Disk	10
Import the Images into the Project	11
Importing Driver Files	11
Import Driver from Project Menu	12
Import Driver from Advanced Edit.....	13
Import Driver from Right Click on Data	13
Set Driver from Existing Data File.....	14
Importing Data Files	14
Import Data from Project Menu	15
Import Data File from Right Click on 3D Data Icon	16
PICTURE VIEW	17
Introduction.....	17
Picture Tools.....	17
Picture Icons.....	18
Picture Bar.....	18
Cursors Bar	19
View Bar	21
Status Bar.....	21
AUTOMEASURING	22
AutoMeasure Components	22
SuperStart.....	23
Initial Bundle	23
AutoMatch	23
Final Bundle	23
The AutoMeasure Dialog.....	24

SCALING MEASUREMENTS	26
Adding Scale Bars	26
Applying Scale	28
THE BUNDLE.....	29
Overview.....	29
Running a Bundle	29
Bundle Dialog.....	31
Bundle Setup	38
Bundle.....	38
Rejection Limit	38
Maximum Iterations.....	39
Triangulation	39
Rejection Limit	39
Sub-Sampling	39
Bundle Statistics	41
Introduction	41
Criteria Tests.....	41
The Number Test (#).....	41
The Percentage Test (%)	41
The Value Test (V).....	41
The Median Test (M).....	41
Icons.....	42
Viewing Picture Summary.....	42
Viewing Points Summary	43
Viewing Scale Summary	45
Bundle Automatic Scale Rejection.....	45
GSI32.INI File Default Settings	46
Bundle General.....	46
Bundle Weak Criteria	49
Bundle Bad Criteria	51
3D VIEWER	53
Introduction.....	53
Viewpoint.....	53
Viewpoint Manipulation.....	53
Using the mouse	53
Panning	53
Zooming.....	54
Using the keyboard	54
Fitting.....	54
Rotating.....	54
Zooming.....	55
Panning	55
Selection	55
Selection Types	55
Single Selection.....	56
Multiple Selection	56
Identification	56

Delete and Rename	57
Delete	57
Rename	57
Display Options	58
View Setup	58
General	59
Tolerances	66
Adjusting the Tolerance	66
Setting the color	67
Color Schemes	68
Display Colors	69
Invert Print	69
Invert Save	69
Additional Display Options	69
Clipping Planes	70

ALIGNMENTS	71
-------------------------	-----------

Introduction	71
Design Data	72
Introduction	72
Importing	73
Comparing Measured to Design	74
Viewing the Differences Graphically	75
Creating Design Data	77
Importing Data from a File	77
Driver File with Design Points	78
Alignment Options	79
Residuals Quick/Standard	79
Axis	80
Quick	81
Standard	81
Changing Standard Deviation Fields	82
File	83
Manual	84
Alignment Setup	84

BASIC MEASUREMENT FUNCTIONS	85
--	-----------

Introduction	85
Functions	85
Average	85
Distance Basic Measurement Functions	86
Vector	86

SOLIDS	87
---------------------	-----------

Introduction	87
Creating Objects	88
Planes	88
Lines	90
Circles	91
Spheres	94

Curves.....	94
Measurements	95
Plane to Plane.....	95
Line to Line	97
Plane to Line	98
Point to Object.....	99
Plane Positive Direction	101
Offsetting Planes.....	102
Point to Object Projection	103
Point to Curve	105

SURFACES	106
-----------------------	------------

Introduction	106
Importing	106
Terminology	107
Commands.....	108
Measurement.....	108
Projection.....	111
Positive Direction	111
Surfaces in the Project	113

CONSTRUCTION OBJECTS.....	114
----------------------------------	------------

Introduction	114
Importing	115
Construction Objects.....	115
Vector Points	115
Average Points.....	116
SOLIDS Objects	118
Measurement Objects	119

REPORTS.....	123
---------------------	------------

Introduction	123
Setup	123
Creating.....	125
Template Files.....	126
The general section	126
The data section.....	126

FILE MENU	128
------------------------	------------

New Project.....	128
Open Project.....	128
Close.....	129
Save.....	129
Save Image As.....	129
Export Data Files	130
Report.....	132
Report Setup	132
Print.....	133

Print Preview	133
Print Setup.....	134
Recent Projects.....	134
Exit.....	134

PROJECT MENU	135
---------------------------	------------

Advanced Edit.....	136
Import	136
General Parameters	137
General - Camera.....	137
General - M Mode.....	137
Scanning Parameters –S-Mode	138
Scanning Parameters – M-Mode.....	138
Target Criteria.....	139
Ring Criteria	140
Code Criteria.....	141
Bundle.....	142
INCA Camera	142
Coded Target	143
Scale Bars.....	144
AutoMeasure	145
Global Point Edit.....	145
Update	146
Restore	147
Import.....	148
AutoBar.....	148
Driver	149
Data File	149
Probes	149
Images.....	150
Setup.....	150
Bundle	151
Triangulate.....	152
All Points.....	152
New Point(s).....	153
Bundle	153
MMode	153
AutoMatch	153
All Pictures.....	154
Three Pictures	154
Setup.....	154
Label Setup	154

MMODE MENU.....	155
------------------------	------------

Introduction.....	155
-------------------	-----

COMMAND MENU	156
---------------------------	------------

SuperStart	156
AutoStart.....	157
Resect	157

Line	158
Find	158
Next String.....	158
Target Search.....	158

PICTURE MENU	159
---------------------------	------------

From Camera.....	159
From Disk.....	159
Next	160
Previous.....	160
Close.....	160
Reset.....	160
Delete.....	161
Contrast	161
Set Label	161
Quit Review Mode.....	161

VIEW MENU	162
------------------------	------------

Picture Bar	162
Cursors Bar	163
View Bar	164
Status Bar	164
Construction Bar	165
Movement Bar	165
Show Data Window	165
Show Zoom Window	165
Show Labels.....	165
Show Crosses.....	165
Show Scan Points.....	165
Show Objects.....	165

TOOLS MENU	166
-------------------------	------------

Customize	166
Zippping a Project.....	167

RIGHT CLICK MENUS	168
--------------------------------	------------

Cameras Icon	168
Pictures Icon.....	169
Data Icon.....	171
Right-click on Design Points.....	175
Right-click on Multiple 3D Files.....	175
Right Click on Points in Design	176
Right-click on Measured Points.....	176
Right-click on Created Objects.....	177
Right-click on Measurement objects.....	179
ScaleBars Icon.....	187
Recycle Bin Icon.....	188
Right Click on Picture Thumbnails	188

Right Click in Picture.....	189
SuperStart.....	189
Right Click in Graphical View	190
Solids.....	191
Alignment.....	191
AutoMatch	191
Average	192
Distance	192
Vector	192
Scale	193
Measured.....	194
Design	194
Probe.....	194
Import.....	194
Update	195

ICONS.....	196
-------------------	------------

Introduction.....	196
-------------------	-----

KEYBOARD COMMANDS	200
--------------------------------	------------

Basic Keyboard Commands.....	200
View	200
Display	201
Object Analysis and Creation.....	201
Surface Analysis.....	201
Advanced Keyboard Commands.....	202
New Keys.....	202

INDEX.....	203
-------------------	------------

Starting a V-STARS Project

New Project

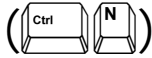

The **New** command is used to commence a new V-STARS project. The **New** command is located under the **File** menu.

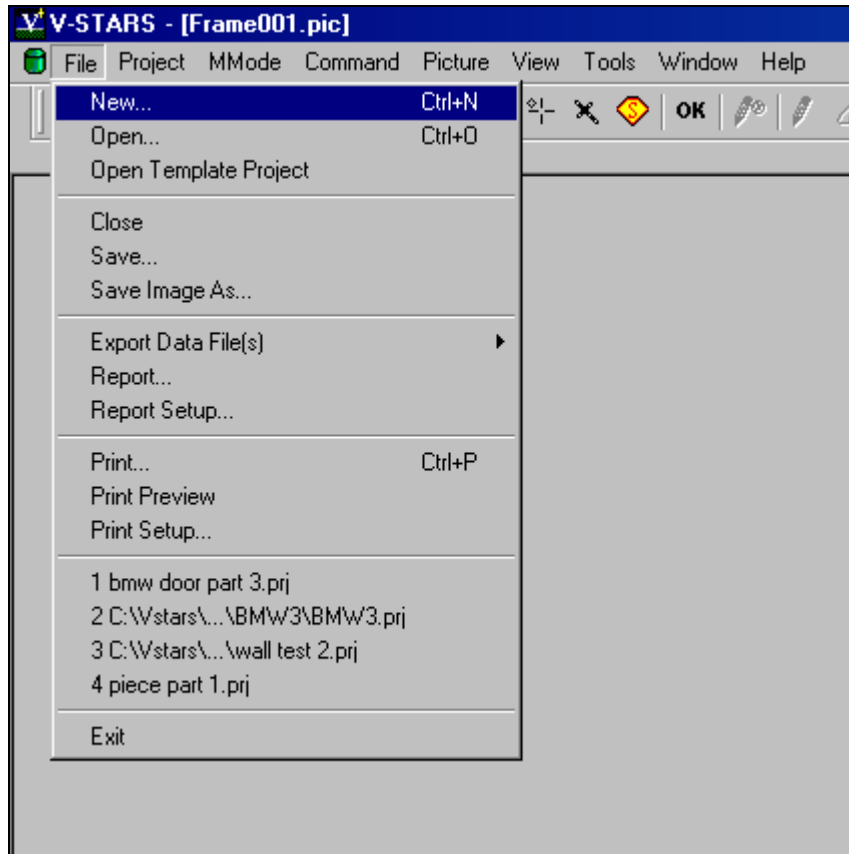

A new project will be started using the default V-STARS settings. If only one camera is present in the system directory, then this camera will be automatically added to the project. If multiple cameras are present, then you will be prompted to select the camera used to collect the images. If the PCMCIA drive is present, then V-STARS will prompt you to indicate the JOB folder the images are stored in. The image path can also be set manually.

Refer to the [Importing Images](#) section for more information on importing images.

Once **New** is selected, the **New** Dialog box will be opened. You are required to specify a directory and project name. The default directory is typically C:\V-STARS\Projects and the project is normally given a meaningful name. The **Open** button will create the new project and all the necessary setup files used by V-STARS.

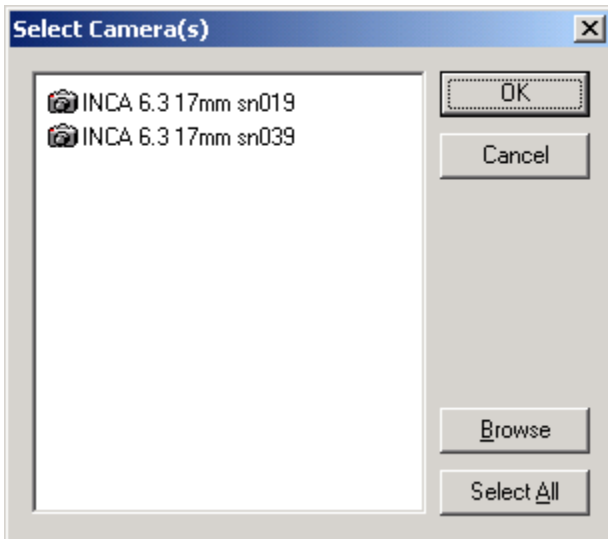
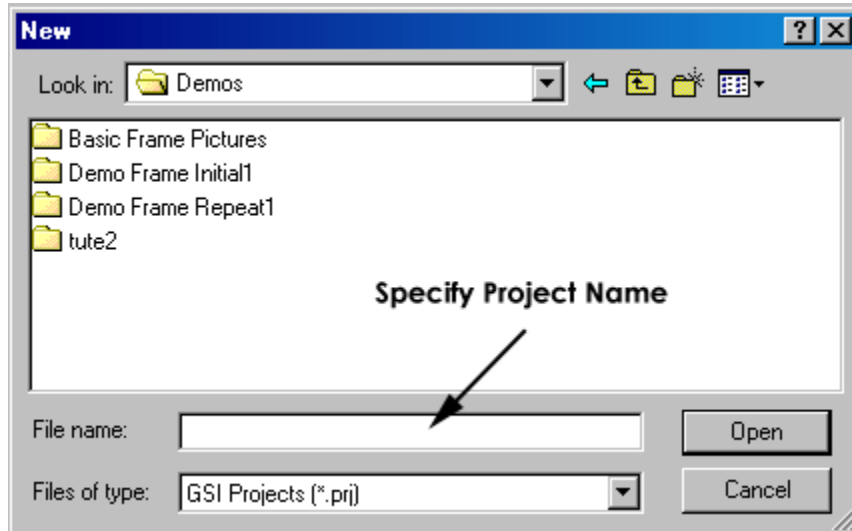

If more than one camera is present in the system directory, then the **Select Camera(s)** dialog will appear. The cameras located in the C:\GSI\System directory are listed. If the camera used to collect the images is in the list, select it and press the **OK** button.

If the camera used is not listed, press the **Browse** button to locate the camera. The camera can typically be found on the PCMCIA card used to collect the pictures.

If two or more cameras are selected, then the last selected in the list will be the default or active camera. A green icon  denotes the active camera. To change the default camera double click on the camera you wish to make the active.

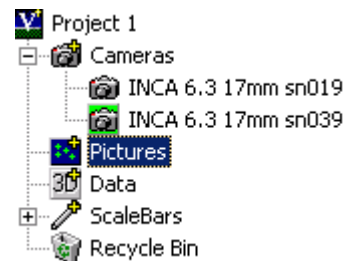

 If the **Cancel** button is pressed on the **Select Camera(s)** dialog, then the new project will be terminated.

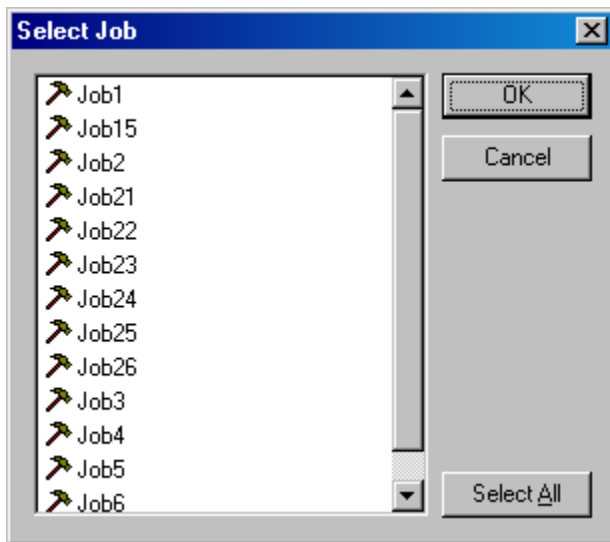

If the PCMCIA disk is in the PC, and is the active drive, then the **Select Job** dialog will appear.

Select the Job that contains your pictures and press the **Open** button. The images thumbnails will appear in your project.

If there is no PCMCIA active or the images are stored directly on another drive refer to the [Importing Images](#) section.

Opening an Existing V-STARS Project

Open Project

The **Open** command is used to open an existing V-STARS project. The **Open** command is located under the **File** menu. The project will be opened using the same settings as when the project was closed or saved.

Once **Open** is selected, the **Open** Dialog box will be opened. Select the directory and then the project name you wish to open. Press the **Open** button. The project will load.

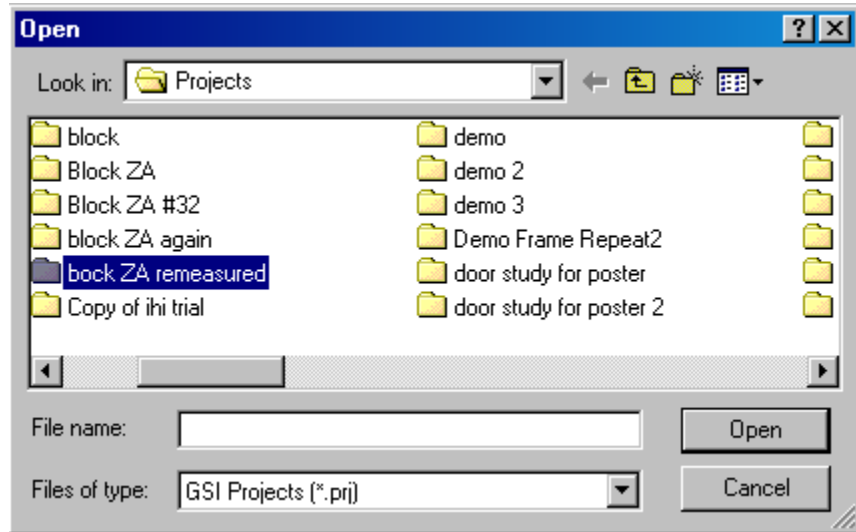

If the image thumbnails are grayed out, you will need to re-specify their location.

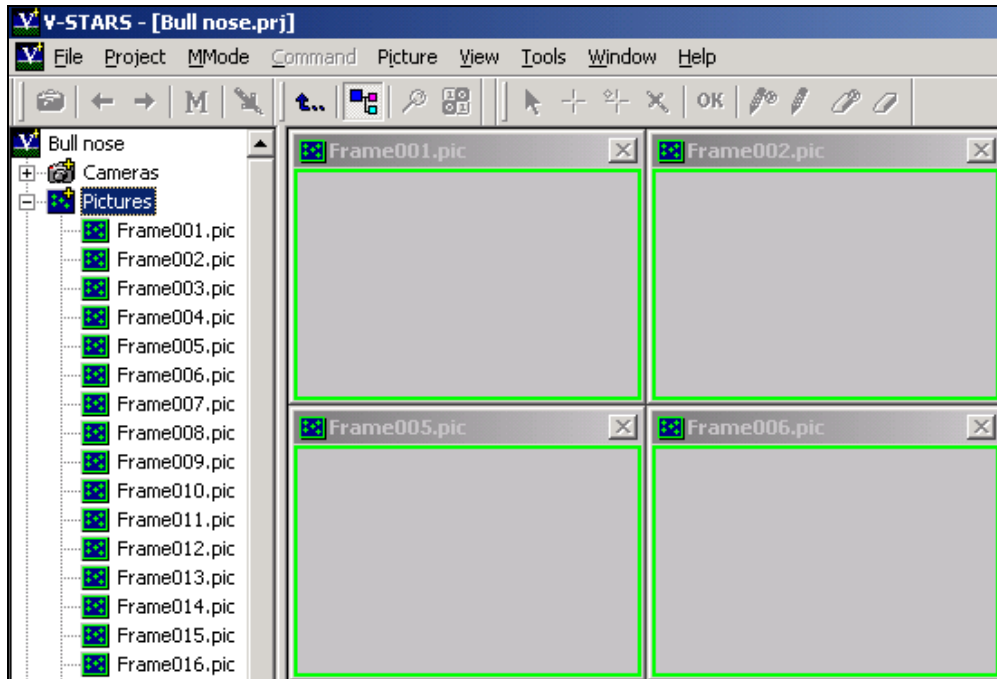

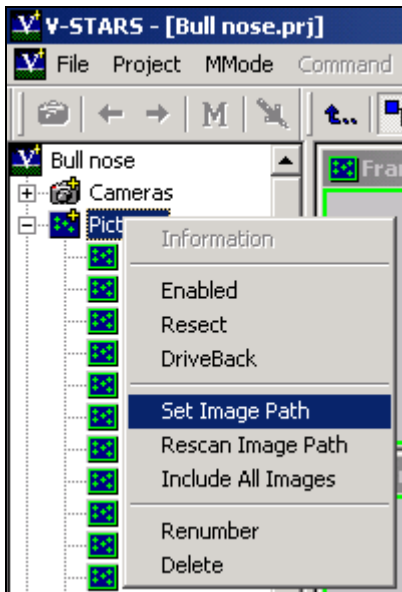

To reset the image path, right click on the Pictures [icon](#) and select **Set Image Path**. Set the directory to the location of the images and click the **Open** button.

Alternatively, the **From Disk** command located under the **Picture** menu can be used to reset the image path. It will load a dialog that can be used to navigate to an image path. The dialog is shown below:

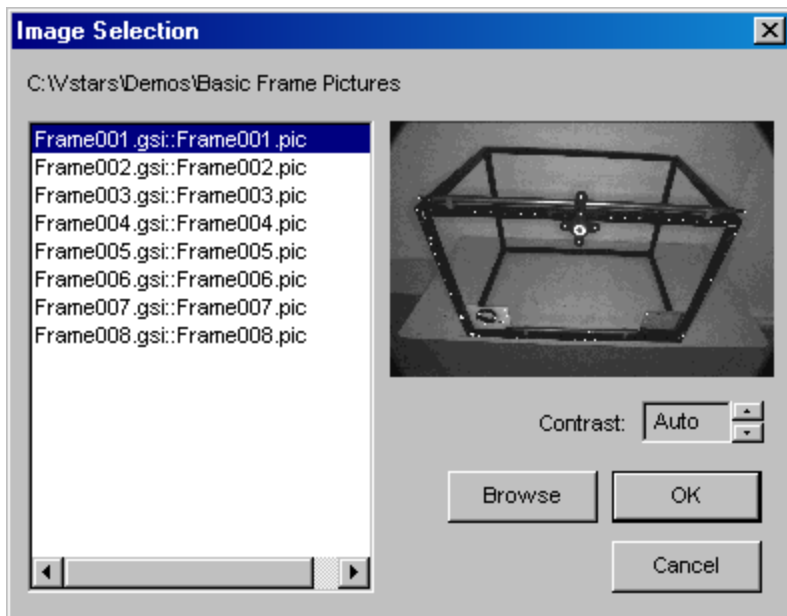

Press **Browse** to select the path that the images can be found in. When a folder with GSI images has been located, a thumbnail of the selected file will be displayed. Adjust the Contrast controls to adjust the image contrast.

This command is also very useful to view different Jobs and carry out Job housekeeping.

Template Projects

Introduction

V-STARS allows the use of template projects. Template projects greatly improve repeat measurements by allowing you to set up a template that contains all the necessary project files. Once set up, the template can be used repeatedly. A template project is setup by creating a new V-STARS project and importing all of the desired files into this project. Once the project is configured with all desired files and settings, it is saved into a special file folder:

C:\Gsi\System\Templates\Projects.

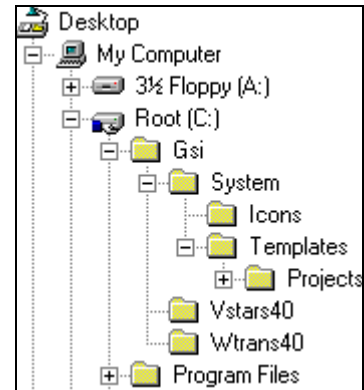

Creating a New Template Project

Create a new template in the same manner that you create any new project, by selecting **New** from the **File** menu.

However, when creating a template project, create it in the

C:\Gsi\System\Templates\Projects directory.

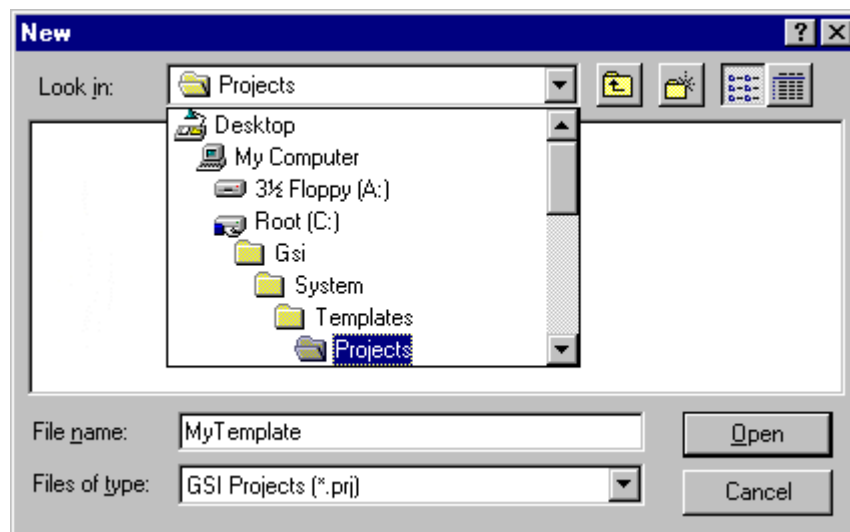
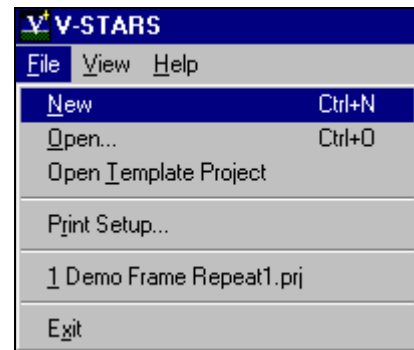

In this example, the new template project is given the name *MyTemplate*. Continue by selecting the appropriate camera, importing the desired Driver File etc. In addition, you may copy into the template project directory any related files that are not part of V-STARS. For instance, if an Excel Spreadsheet is used in conjunction with this project, that file can be copied into the template project directory. When a new project is created from this template, V-STARS will copy all files from the template project directory, including files not directly associated with V-STARS.

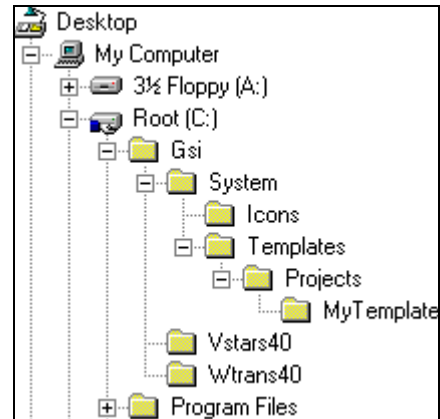

 If you do not include a camera in your template project, V-STARS will prompt you to select one when the template project is opened.

Opening a Template Project

Once a template project is created, select **Open Template Project** from the **File** menu.

You will then be asked to choose from a list of templates.

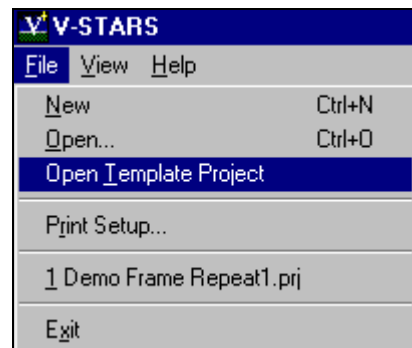
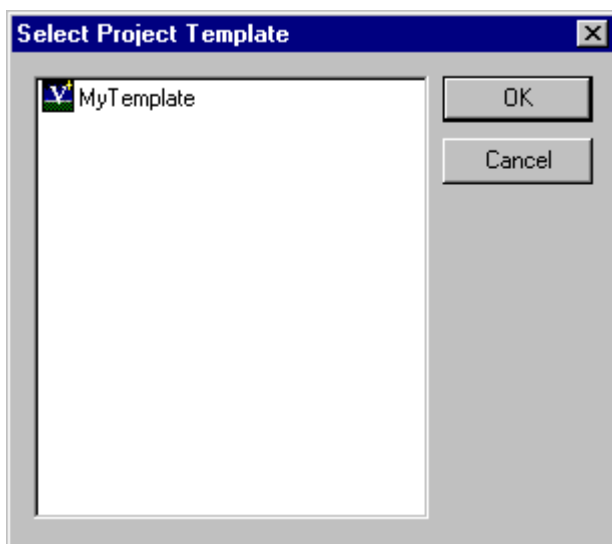

Select the desired template and press **OK**.

Destination folder

The destination folder of a project opened from a template depends on an entry in the GSI32.INI. The entry is in the general section and is called `ask project template root`.

```
ask project template root=TRUE
```

If `ask project template root` is set to `TRUE`, upon selecting the desired template from the **Select Project Template** dialog, you are prompted for a destination folder and name for the new project. This way, you can specify any location as the project directory.

If, however, `ask project template root` is set to `FALSE`, the destination folder is `C:\Vstars\Projects\MyTemplate_x` where `x` continues to increment each time the template is used.

Importing Files

Import Images

Setting the Image Path

The image path can be set in a number of ways. The method used will largely depend on your preference. The Default occurs at the start of a project and is largely taken care of by V-STARS. The various methods are described below.

Default

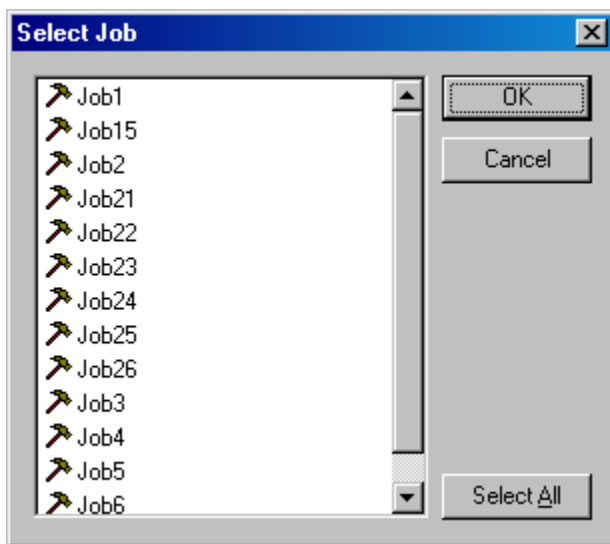

When starting a new project, if the PCMCIA disk is in the PC, and is the active drive, then the **Select Job** dialog will appear.

Select the Job that contains your pictures and press the **Open** button. The images thumbnails will appear in your project.

Manually Setting the Image Path

To set the image path, right click on the Pictures icon (🖼️) and select **Set Image Path**.

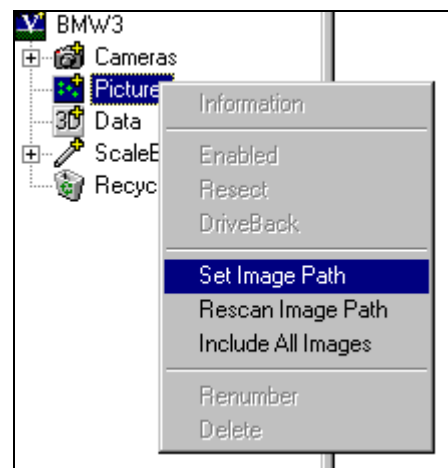

Set the directory to the location of the images and click the **Open** button.

The images thumbnails will appear in your project.

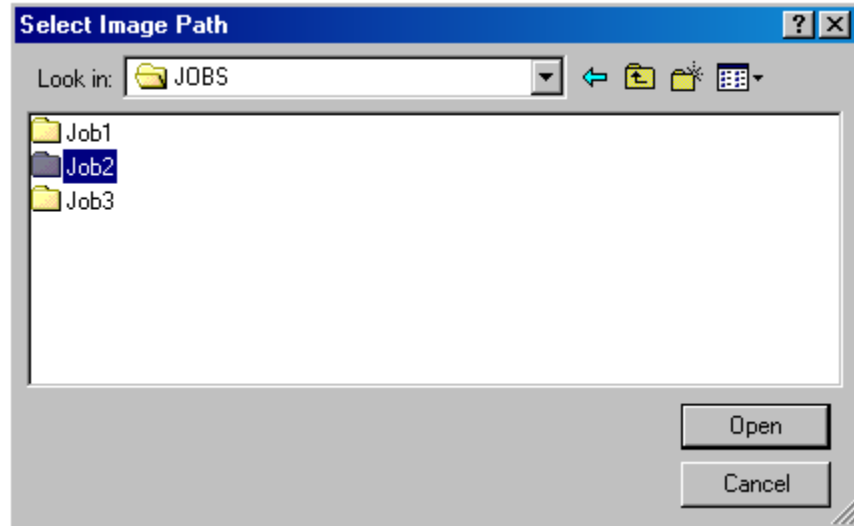

Picture from Disk

The **From Disk** command is located under the **Picture** menu and can be used to set or reset the image path. It will load a dialog that can be used to navigate to an image path. The dialog is shown below.

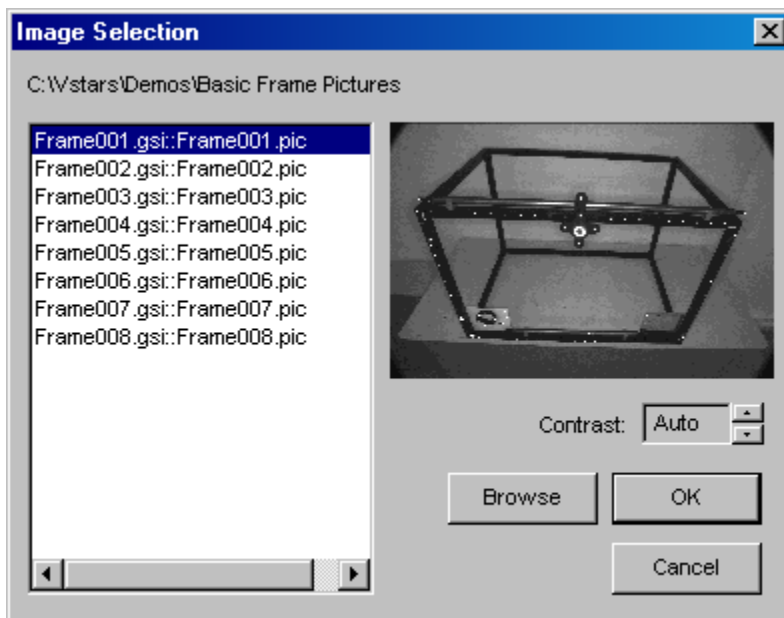

Press **Browse** to select the path that the images can be found in. When a folder with GSI images has been located, a thumbnail of the selected file will be displayed. Adjust the Contrast controls to adjust the image contrast.

This command is also very useful to view different Jobs and carry out Job housekeeping.

Import the Images into the Project

The **Import Images** command is used to copy the image path images directly into the Project Directory. If the images are not already GSI files, they are converted during the import.

The **Import Image(s)** command is under the **Project** menu. The image path that has been set determines what images will be imported. If the image path has not been set the following dialog will appear.

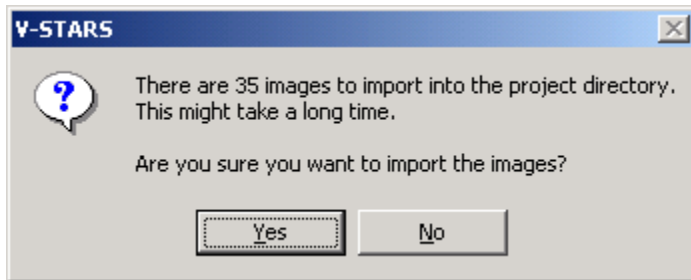
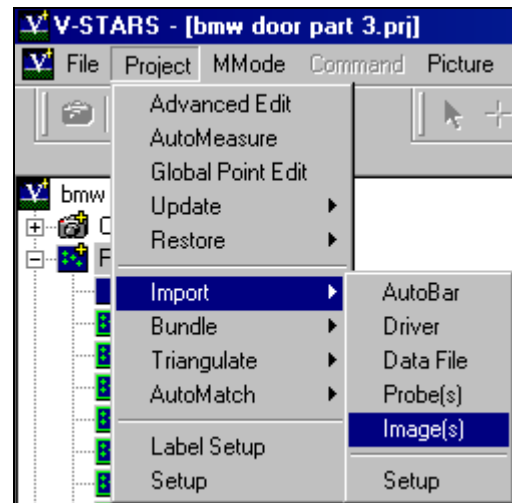
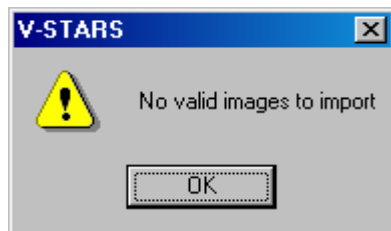

Prior to the import, you will be given a warning relating to the time it may take to import the images to your project. Press **No** to cancel the import.

 Import images prior to using the [Zip With Images](#) command under the **Tools** menu.

Importing Driver Files

Driver files can be imported in a number of ways. The method used will largely depend on your preference. The driver files that can be imported are **3D**, **XYZ** or **IGES** files.

Import Driver from Project Menu

The **Import** command opens the following dialog. Select a 3D, XYZ or IGES file to import it into the project and set it as the current driver. If this file is in the "XYZ" format V-STARs will prompt you for the files units.

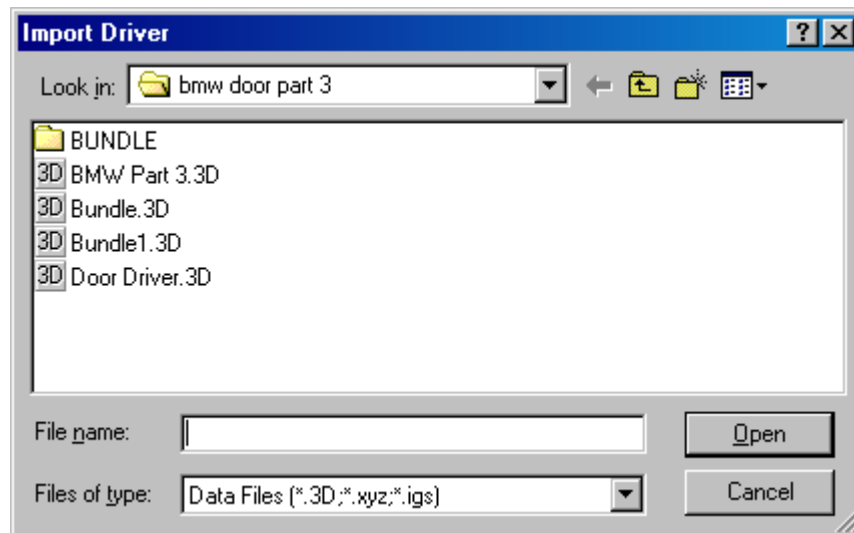
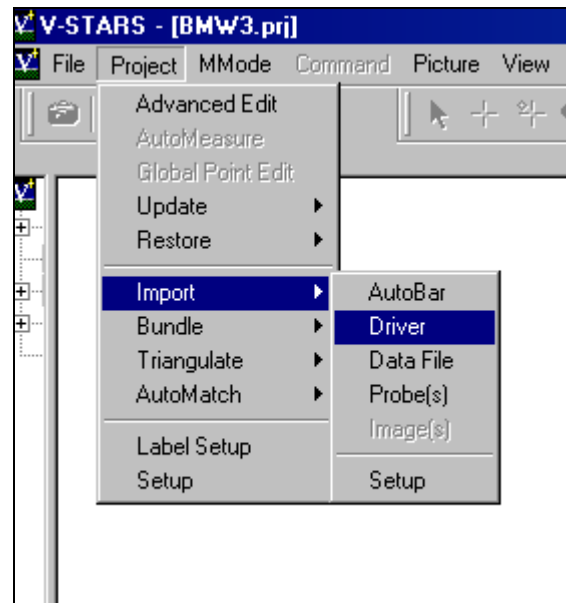



A summary of the imported points is shown and the file is added to the project as the driver.

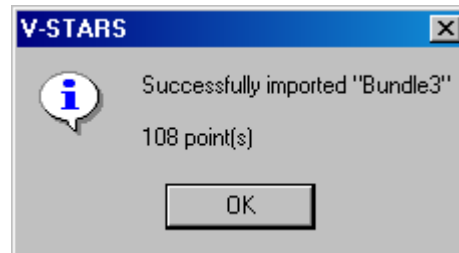

Import Driver from Advanced Edit

The **Import** command can also be accessed via the **Advanced Edit** dialog under the **Project** menu. Once the **Import** command is pressed the procedure to import a driver is the same as the one described in the [Import Driver From Project Menu](#) section.

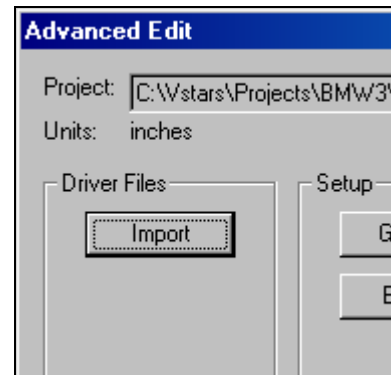

Import Driver from Right Click on Data

A right click on the 3D data node in the main project tree will access the **Import** command.

Once again, the import procedure is the same as the one described on the [Import Driver From Project Menu](#) section.

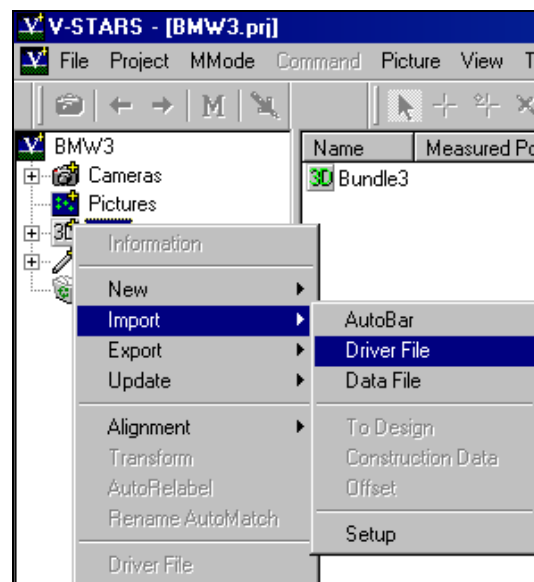

Set Driver from Existing Data File

To set a 3D file as the driver file, right click on it and select **Driver File**. If the file is already the driver file then it will become a normal 3D file.

When a new file is selected as a driver, you will be prompted to re-reset all the pictures in the project.

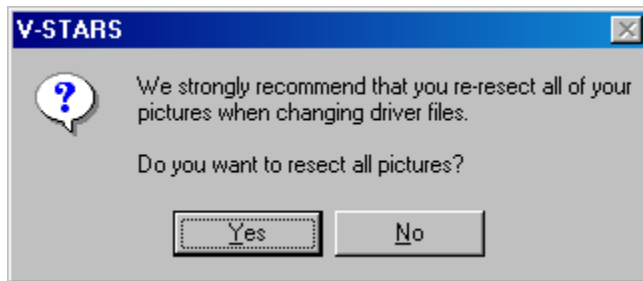

It is advisable to re-reset the images.

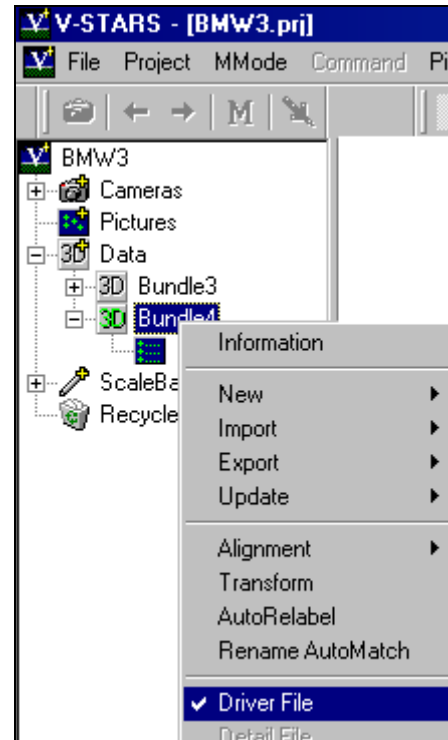

Importing Data Files

Data files are imported using the **Import Data** command under the **Project** menu or by right clicking on the 3D Data [Icon](#) of the project tree. The data files that can be imported include **3D**, **XYZ** and **IGES** files. The files imported are saved as 3D files.

 A driver file can be converted into a regular data file by right clicking on it and deselecting the **Driver** setting. Conversely, a data file, can be set as a driver file by selecting the same flag. Refer to [Set Driver from Existing Data File](#) for more information.

Import Data from Project Menu

The **Import** command opens the following dialog. Select a 3D, XYZ or IGES file to import it into the project. If this file is in the "XYZ" format V-STARS will prompt you for the files units.

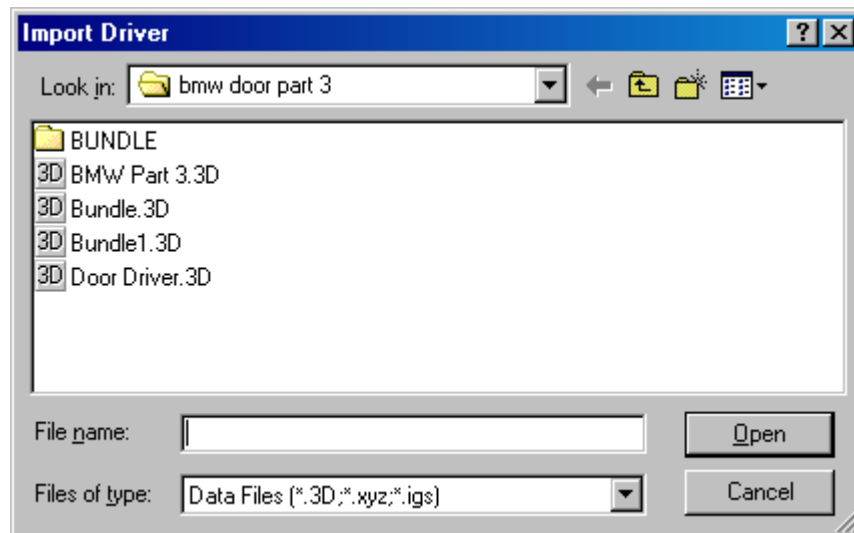
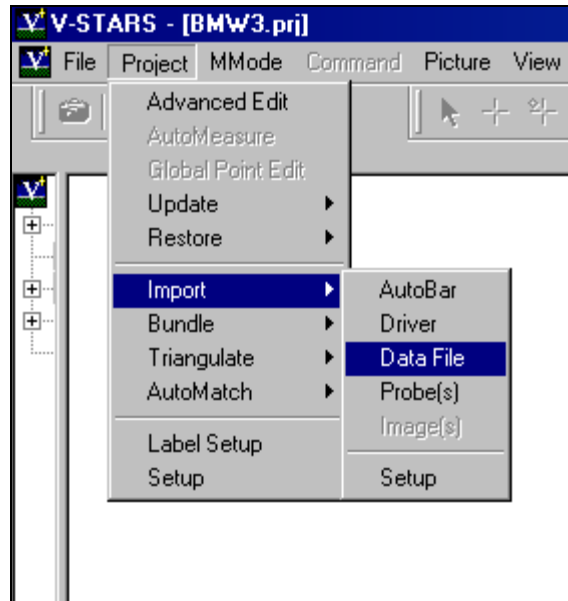

A summary of the imported points is shown and the file is added to the project.

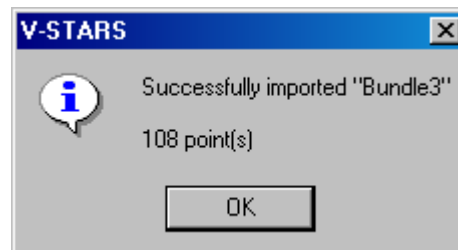

 If the name of the file already exists in the project, then the name will be incremented numerically to the next available name.

Import Data File from Right Click on 3D Data Icon

A right click on the 3D data [icon](#) in the main project tree will access the **Import** command.

The import procedure is the same as the one described on the [Import Data from Project Menu](#) section.

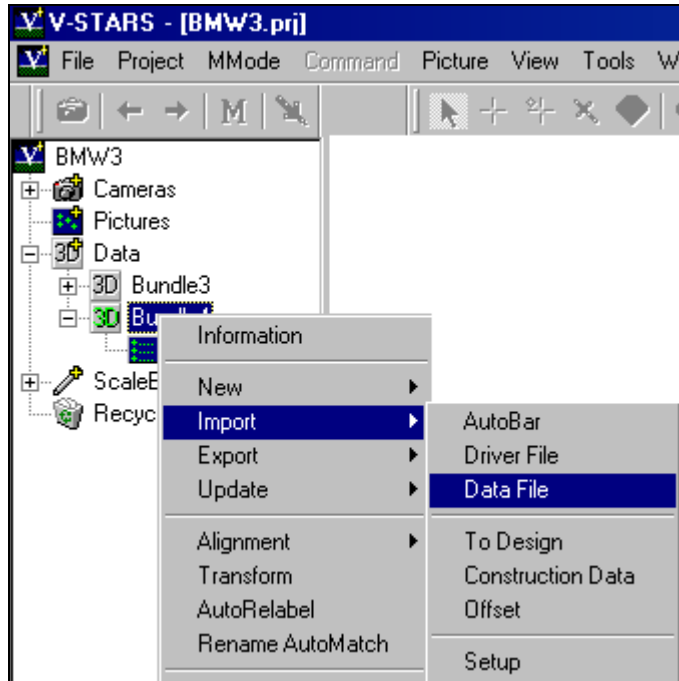





Picture View

Introduction

This section of the manual describes some of the aspects of the Picture View. To open a picture, click on its thumbnail. A "picture window" will appear with the full image.

Picture Tools

The small window seen in the picture is called the Zoom window. It is like a magnifying glass into the picture window. As you move the cursor over the picture, you will see a magnified view in the Zoom window. The green rectangle in the Zoom window is the measuring area, also known as the Region of Interest (ROI); the target center must be inside this rectangle to be measured. You can zoom in and out of image using the  /  keys. The Zoom window contrast can be adjusted using the  /  keys.

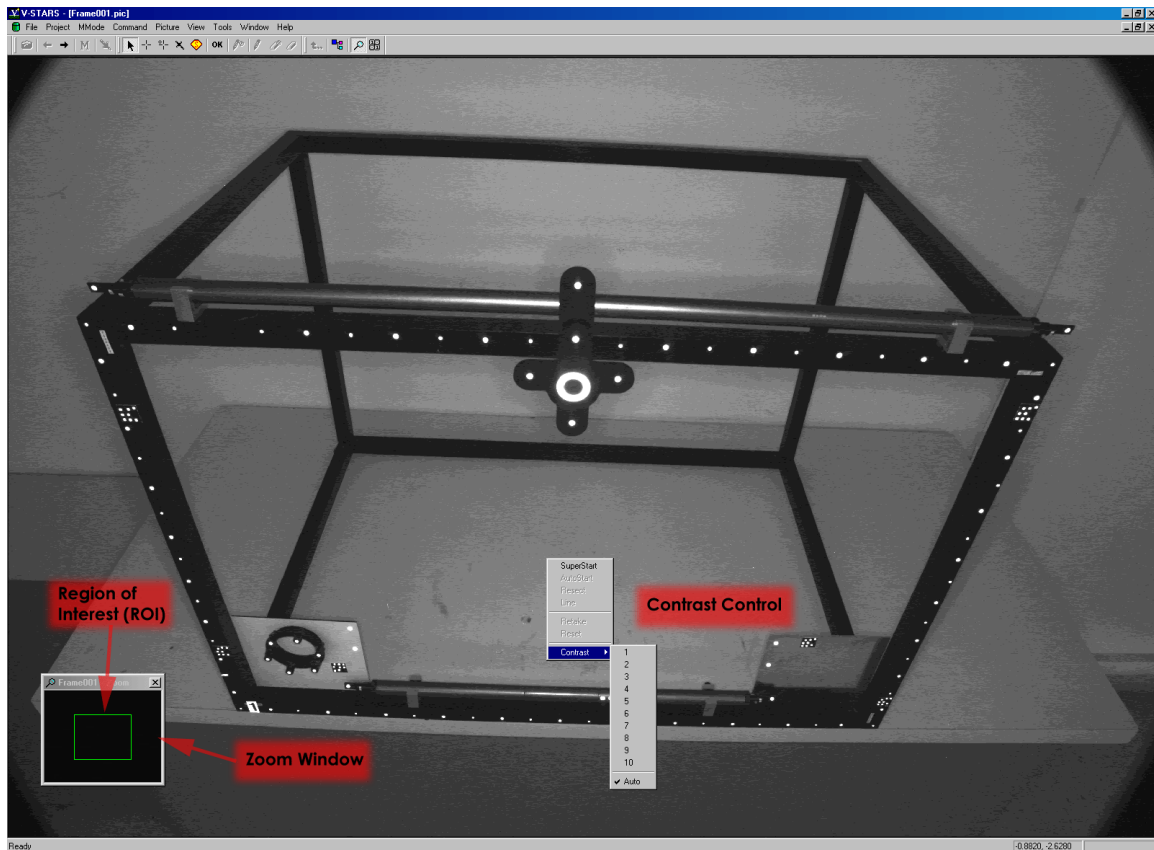

Generally, the picture contrast will be enhanced. To see what the picture actually looks like, select **Contrast** from the **Picture** menu and select "1". Notice now the picture is darker. We have deliberately underexposed the background

to make the targets easier to find and measure. V-STARS can automatically adjust the contrast for each picture when the contrast is set to **Auto**. We usually recommend you use this setting.

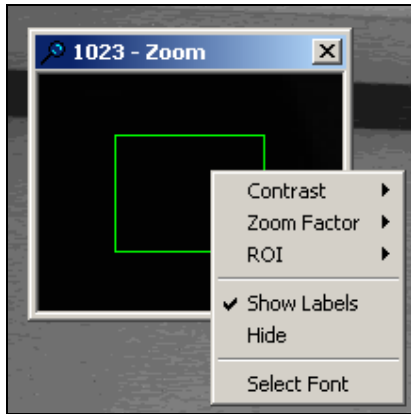

Contrast – Adjust the contrast of the Zoom Window.

Zoom Factor – Adjust the Zoom Window zoom factor.

ROI – Adjust the Region of Interest size.

Show Labels – Toggle the label display.

Hide – Hide the Zoom Window.

Select Font – Change the Zoom Window font.

 You can also access some of the more frequently used commands by right-clicking the mouse in the picture window, and selecting the command from the pop-up menu.

 The picture contrast setting has no effect on the measurement; it only helps you see the picture.

Picture Icons

Many of the functions accessible in the Picture View are controlled using the Picture Icons.

Picture Bar





The Picture Bar features five icons. These have the following functionality.

 **Camera Icon** – Take a picture. Only active if one or more cameras are online. This command can also be initiated from the **Picture – From Camera** menu.

 **Previous Image** – Go back one image. When the first image is already active, the left arrow will be dimmed.

 **Next Image** - Go forward one image. When the last image is already active, the right arrow will be dimmed.

 **M Icon** – Initiate Multi-camera mode. Only active if two or more cameras are online

 **Probe Icon** – Trigger the cameras in Multi-camera mode to fire simultaneously. This icon is only active if two or more cameras are online, and in M Mode.

Cursors Bar



The Cursor Bar is made up of nine icons. These have the following functionality.

 **Selection Cursor** (F1) – This is the default cursor. This cursor must be active when you wish to do any point selection.



 **Cross Cursor** (F2) – Use this cursor is manually locate points in the image that are located in the driver file. If the label of a driver point is set the cursor will automatically change from the Selection Cursor to the Driver Points Cursor.

 **New Points Cursor** (F3) – Use this cursor is manually measure new points.

 **SuperFind Cursor** (F4) - This feature allows new points to be measured in all images (in which they exist) by measuring them in a single image. The point is measured in the current picture and then automatically in any other pictures that see the point. The point is then automatically triangulated and added to the current driver file. SuperFind is especially useful for picking up occasional points that were not AutoMatched, or for re-measuring points that were inadvertently deleted. For best results, you should usually re-run the bundle after you have measured any new points with SuperFind.

For SuperFind to work, you must have a good solution for the camera calibration, and a good resection solution for each picture. Normally, you will use SuperFind after you have let the AutoMeasure process run to conclusion. In this case, you will have a converged bundle solution, so the conditions above will be met. You can also use SuperFind after the AutoMatch portion of AutoMeasure is completed, but your success will depend on how good the camera and picture solutions are at that time.

This feature is implemented in much the same way you globally relabel a point.

1. Open the picture that has the point(s) that you wish to measure.
2. Select the SuperFind cursor  from the measurement toolbar.
3. The cursor will change to the shape of the SuperFind cursor. 
4. Type in the point label that you wish to assign to the new point.
5. Move the point inside the measurement window.
6. Click on the point. The point should now be marked with a cross and labeled.
7. Repeat steps 3-6 for any other points. If there are other points you want to measure that are not in this picture, just close the current picture, and open those picture(s) one at a time and repeat steps 3-6.
8. The 3D coordinates of the points will be automatically added to the current driver file. For the highest accuracy, you should re-run the bundle after all points are measured.



The point must be in at least three pictures for SuperFind to work. If the point is not measured, the point will not be marked with a cross or relabeled. Otherwise, the point will be added to the current driver file. If you know the point is in at least three pictures, but is not measured, then the camera and/or picture solutions are probably not good enough to use SuperFind yet. If this is the case, it is advisable to run the bundle to get a better solution.



OK Cursor – AKA "God Mode". This cursor is used in conjunction with the Driver and New point cursor. When activated all the target criteria rules are disabled. This means that targets that fail the acceptance criteria can still be measured. **WARNING** – Including unacceptable targets in the measurement can produce inconsistent and inaccurate results.



Global Rename Cursor – Use this cursor when you wish to rename points in the images or driver file. All observations to the point will be renamed with the new label. Note that points in the previous Bundles will NOT be renamed.



Rename Cursor – Use this cursor when you wish to rename points only in the current image or 3D file.



Global Delete Cursor – Use this cursor when you wish to delete points in the images or driver file. All observations to the point will be deleted. Note that points in the previous Bundles will NOT be deleted.



Delete Cursor – Use this cursor when you wish to delete points only in the current image or 3D file.

View Bar



The View Bar is made up of four icons. These have the following functionality.

Up on level – Press this icon to move one level up the directory tree.

Bring Project to Top (F12) – Press this icon to bring the V-STARS directory to the foreground.

Show/Hide Zoom Window (F9) – Press this icon to activate or deactivate the data zoom window. This icon is only active if a picture window is open.

Show/Hide Data Window (F10) – Press this icon to activate or deactivate the image data window. This icon is only active if a picture window is open. Right click in the data window to view the additional options.

Pixel View – Display pixel grayscale values.

Target View – Display potential target pixels.

Size to Zoom – Resize Data window to match Zoom window.

Hide – Close Data window.

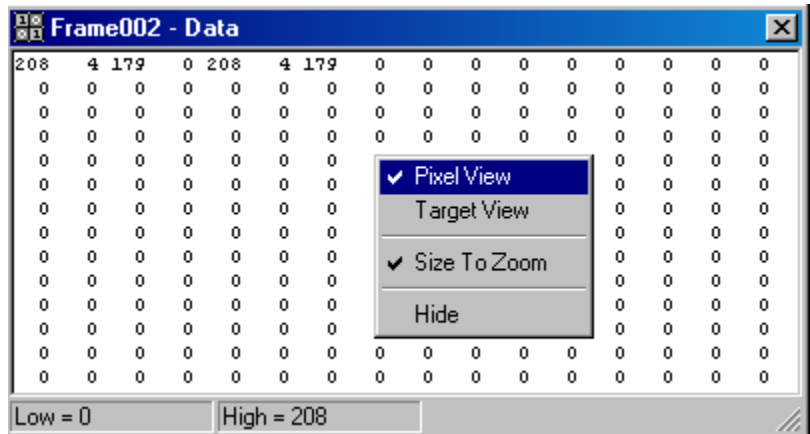

Status Bar



The Status Bar displays the status of V-STARS. If an image is open, the XY location of the cursor will also be displayed.

AutoMeasuring

AutoMeasure Components

The AutoMeasure procedure is a collection of V-STARs routines that are automatically called to automate the measurement of the project. The AutoMeasure flowchart below describes the general steps undertaken by the AutoMeasure routine.

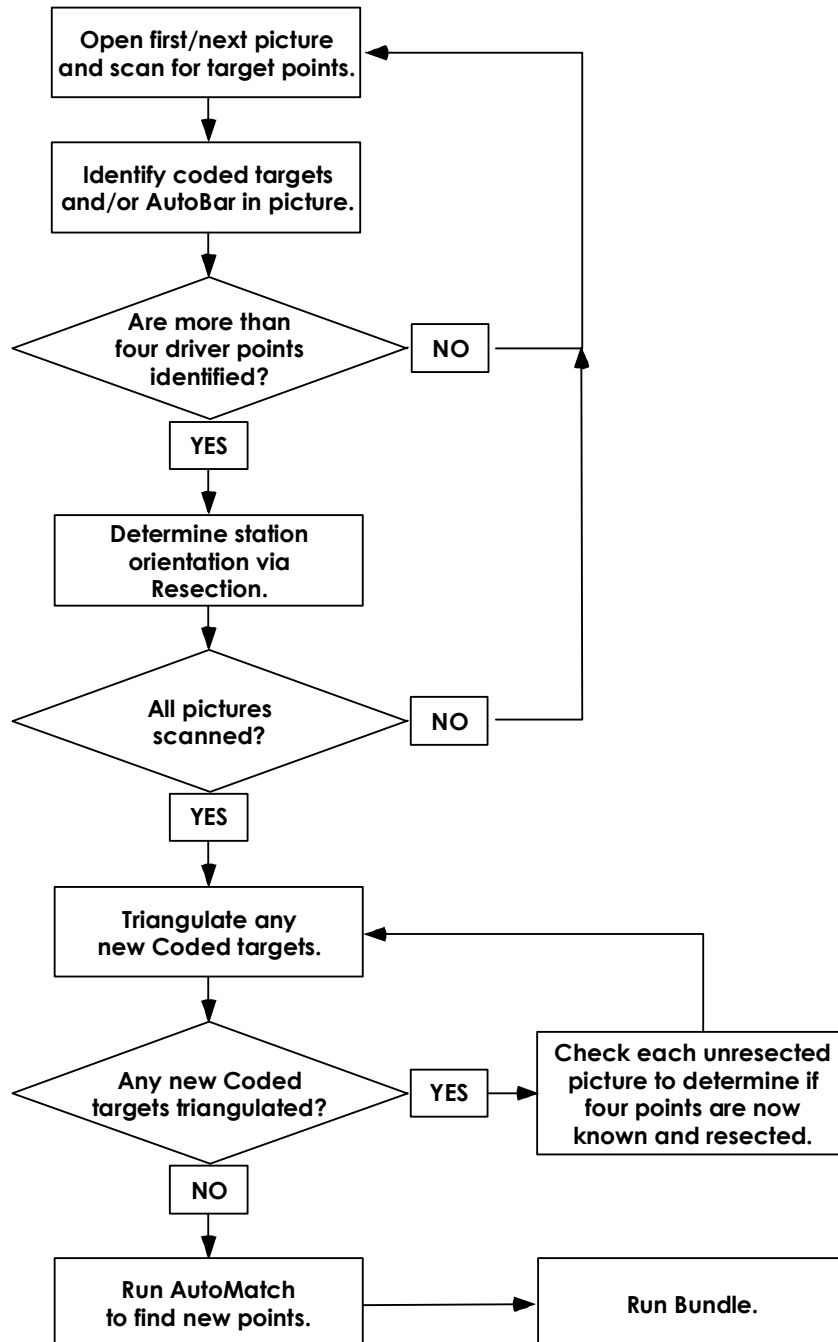

SuperStart

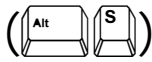

The **SuperStart** command will open the picture and complete the following processes:

- 1) Scan image for potential targets.
- 2) Determine whether an AutoBar is present.
- 3) Decode any codes that are present.
- 4) Use the known (coordinated) coded targets and AutoBar found to determine the location in space (resection) of the image.
- 5) Driveback to any points in the Driver file.

Initial Bundle

The **Initial Bundle** is typically carried out after all the images have been SuperStarted. The objective of the Initial Bundle is to establish with greater accuracy the location of the camera stations and of the points found in the SuperStart portion. These values are needed for the AutoMatching phase of the process. The initial bundle differs from the full bundle in that the Camera Calibration parameters are held fixed. For a more detailed explanation of the bundle process, refer to the [Basics of Photogrammetry](#).



If the **Solve Picture Stations** box is unchecked, the Initial Bundle is skipped.

AutoMatch

The AutoMatch is a routine designed to automatically measured target points in the V-STARS project. The routine uses a sophisticated search routine to determine image point correspondence between points in different images. These observations are then combined to produce a point XYZ for each point AutoMatched. New points found by AutoMatch will be given the keyword name `TARGET` and appended to a number. For example, `TARGET2032`.



If the **Find New Points** box is unchecked, the AutoMatch is skipped.

Final Bundle

All the data that has been produced is passed into the Final Bundle process. The bundle is a very sophisticated mathematical routine that combines all the data together to produce an accurate set of coordinate data. As a byproduct of this process, the camera calibration and camera station values are also determined. For more information, please refer to the [Bundle](#) Section in this manual.

The AutoMeasure Dialog

The **AutoMeasure** command opens the **Measure Project** dialog shown. From this dialog, it is possible to complete the entire V-STARS measurement. The dialog is the interface for a convenient way to automate the measurement process.

The key aspects of the dialog are described below.

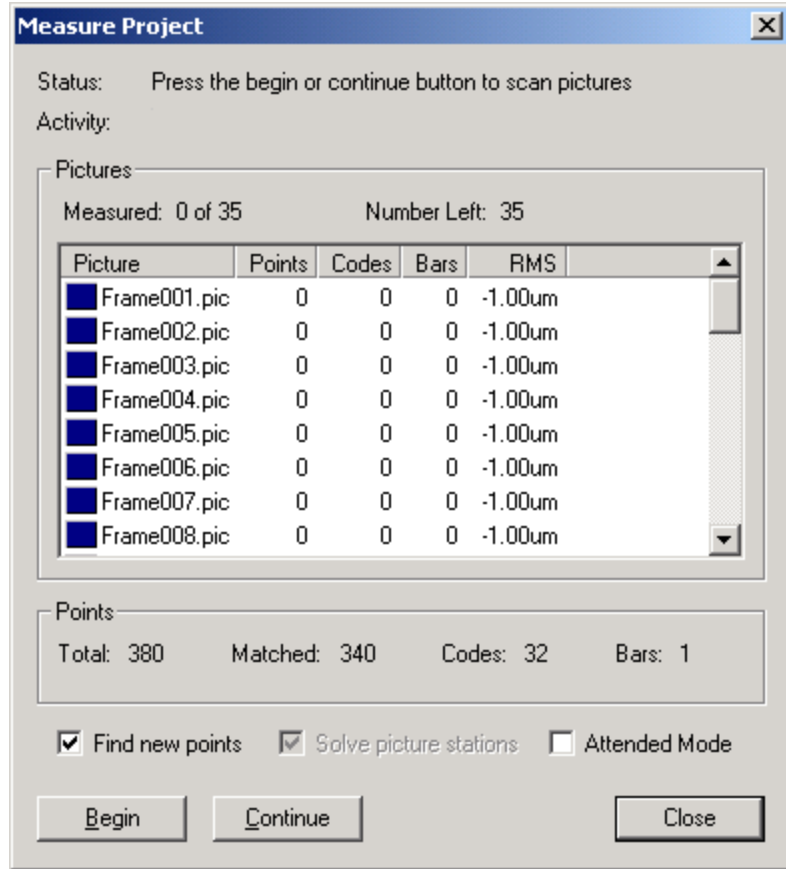

Status – The status area provides you with feedback on what commands need to be pressed to complete the measurement.

Status: Press the begin or continue button to scan pictures

Status: Press the continue button to solve picture stations

Activity – The activity area gives you an indication of how far into a process the procedure is or what stage has been completed.

Activity: Done scanning pictures

Activity: running bundle [6, 1.25um, 34%]

Pictures – This section lists information about the pictures in the project. The number of pictures measured and the number left to be measured are displayed at the top of the frame.

Measured: 35 of 35 Number Left: 0

Picture	Points	Codes	Bars	RMS
Frame001.pic	158	16	1	0.56um
Frame002.pic	153	19	1	0.50um
Frame003.pic	158	17	1	1.13um
Frame004.pic	179	17	1	2.93um
Frame005.pic	82	9	0	0.33um
Frame006.pic	62	8	0	0.51um
Frame007.pic	92	17	1	0.84um
Frame008.pic	148	20	1	0.50um

In the main frame, information about individual pictures is displayed. The number of points, codes, if an AutoBar is present, and the image space RMS values are shown.

Points – The points frame summarizes information about the points in the project. The total number of points, the number matched, the number of codes, and the occurrence of the AutoBar are reported.

Total: 379 Matched: 339 Codes: 32 Bars: 1

Find new points – If this box is checked then the software will run the AutoMatch routine to measure any new points in the images.

Solve Picture Stations – If this box is checked, the system will run an initial bundle after the image scanning to solve for the unknown picture stations. If **Find new points** is checked, then this option will be checked and grayed out.

Attended Mode – If this is checked the AutoMeasure routine will stop at the end of each stage and wait for you to press the **Continue** command.

Begin – Press **Begin** to scan or re-scan the images.

Continue – Press the **Continue** command to continue the next step of the AutoMeasure process.

Scaling Measurements

Photogrammetric measurements are inherently dimensionless and hence must be scaled using an external scale standard. For more information, please refer to the [Basics of Photogrammetry](#).

Adding Scale Bars

Right click on the ScaleBars [icon](#) to add, create or modify scale bars.

New – Create a new scale bar using the following dialog. Enter the scale bar name, the end point labels and the scale distance. Press **Save** to add the new scale bar to the project.

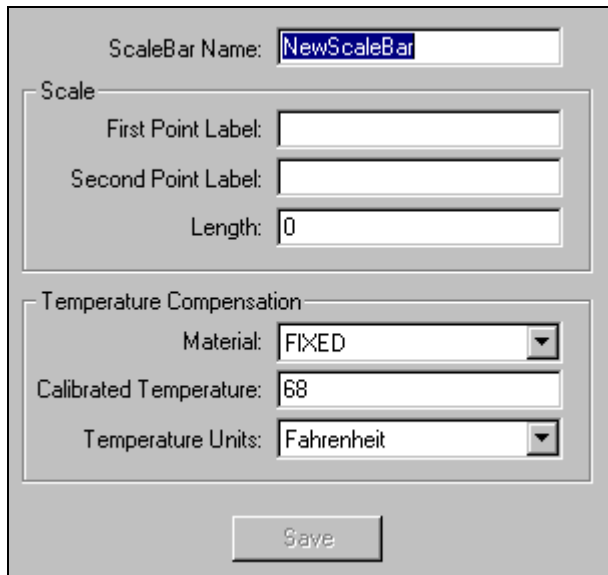

The dialog box for creating a new scale bar. It contains the following fields and options:

- ScaleBar Name:
- Scale section:
 - First Point Label:
 - Second Point Label:
 - Length:
- Temperature Compensation section:
 - Material:
 - Calibrated Temperature:
 - Temperature Units:
- Save button at the bottom.

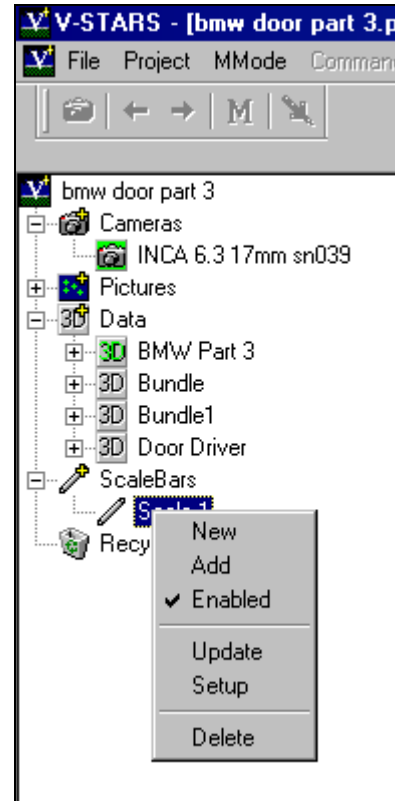

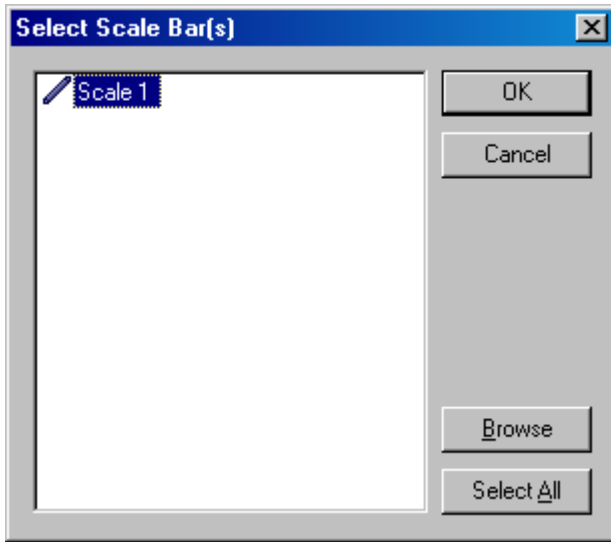

Add – Add a scale bar from the system directory or browse for one from the computer or network.

Enabled – Enable or disable a scale bar by clicking on **Enabled**.

The **Scale Bars** command under the **Advanced Edit** dialog of the **Project** Menu opens the following **Add Scale Bar** dialog.

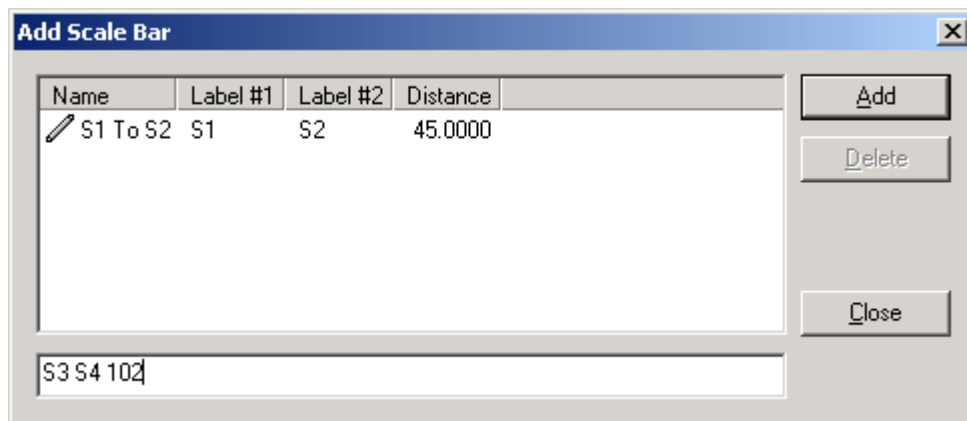

The dialog lists any of the scale bars in the current project. It is also possible to add a new scale bar by typing in the input box at the bottom of the dialog. The input format is as follows

Label1 Label2 Distance

Press the **Add** command to add the scale bar to the project. To delete a scale bar, highlight it, and then press the **Delete** command.

Applying Scale

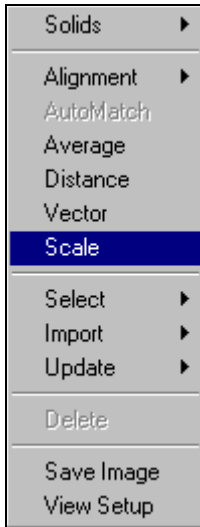

To apply scale to a particular 3D file, right click in the graphical viewer and select **Scale**. The **Scale** function is a convenient way to scale a 3D file without running the Bundle again. The results of the scaling are summarized in a dialog box.

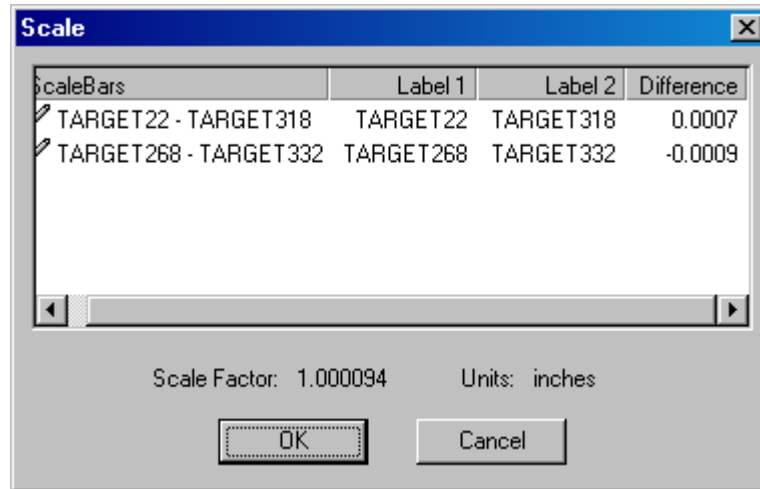

The Bundle

Overview

The Bundle Adjustment is the program that processes the photographic measurements to produce the final XYZ coordinates of all the measured points. In order to do this, it must Triangulate the target points, Resect the pictures and Self-calibrate the camera. The Bundle Adjustment program is called STAR, which stands for Self-Calibration, Triangulation and Resection. Refer to the [Basics of Photogrammetry](#).

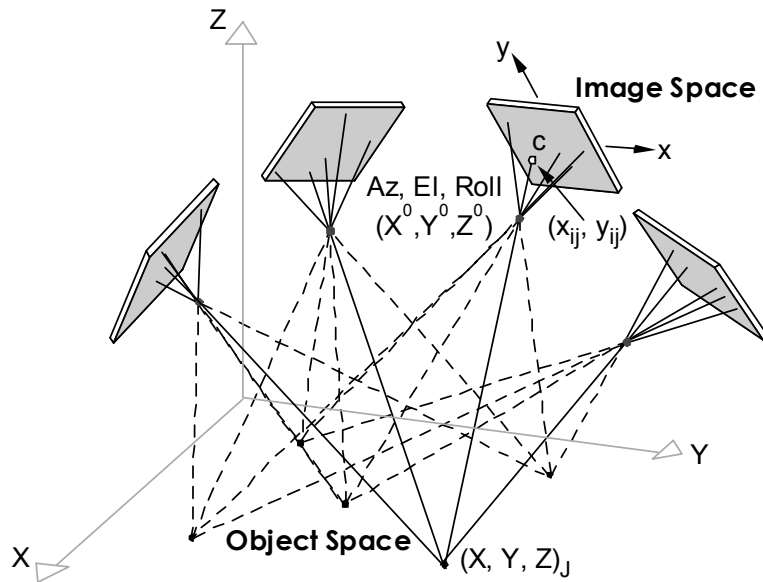

Running a Bundle

The **Bundle** command under the **Project** menu has three options. These are shown below.

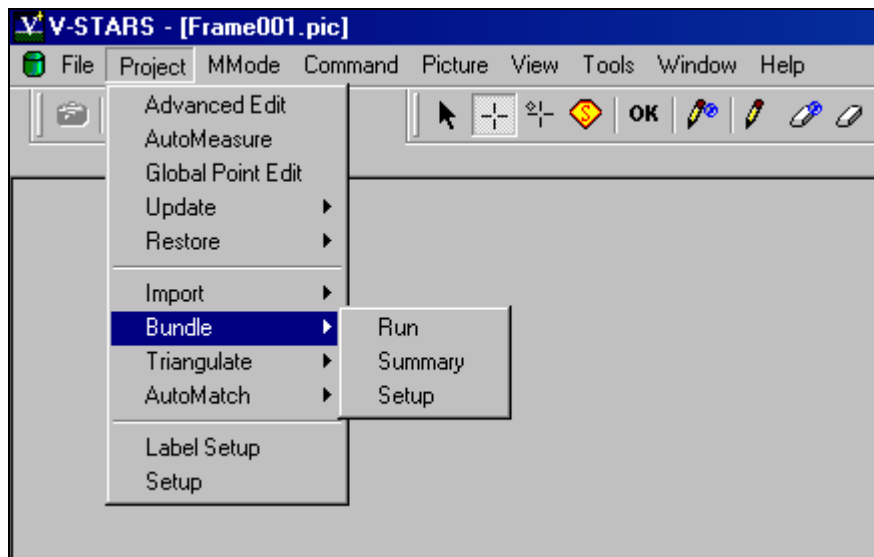

Run When **Run** is selected the main Bundle dialog will be opened.

The **Run** command is dimmed if there are no images scanned or frames resected. It is also dimmed if there are not at least two frames resected.

Summary When Summary is selected, the **Bundle Summary** dialog is opened. A typical summary is shown below.

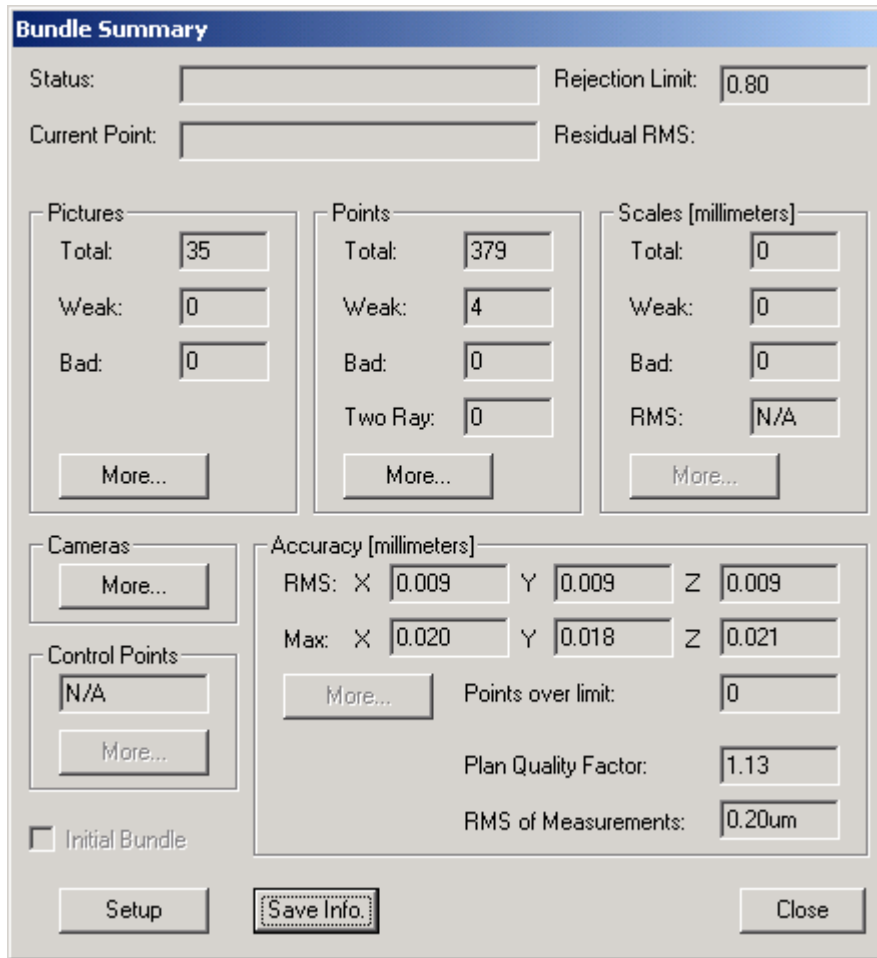

Setup When **Setup** is selected, the **Bundle Setup** dialog is opened. Refer to the [Bundle Setup](#) Section for more information.

Bundle Dialog

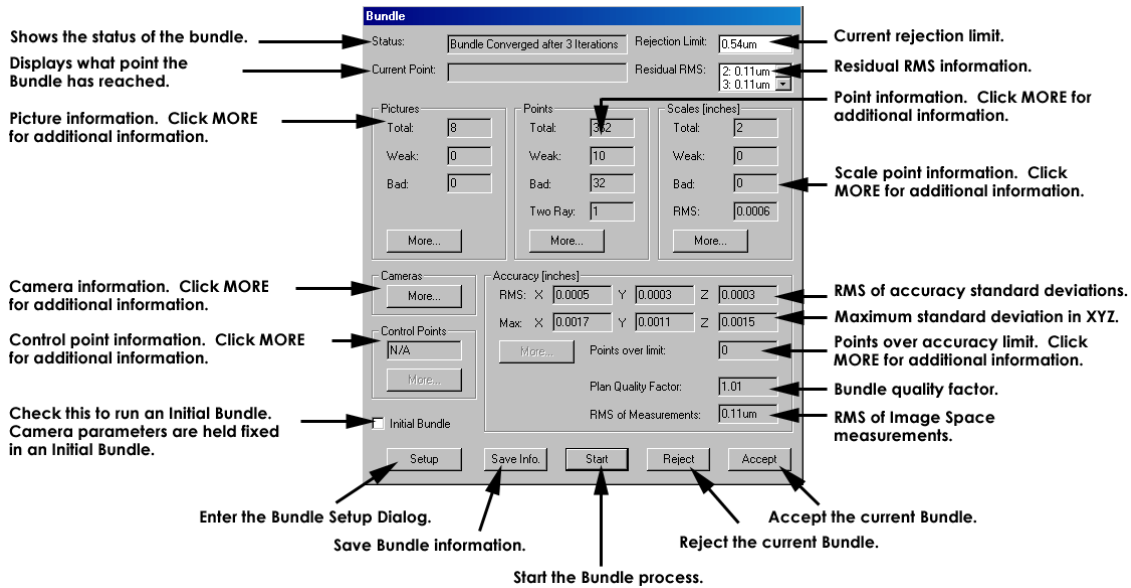

Status – The status box displays the progress of the Bundle. While the Bundle is running it will display the current iteration number. When the Bundle has converged it will display a Bundle Converged message.

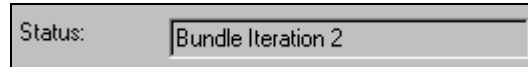

Current Point – The Current Point box displays the progress of the Bundle within the current iteration.

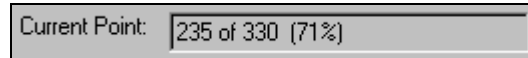

Rejection Limit – The Rejection Limit box displays the value at which picture point observations are being rejected in the Bundle solution. When the Bundle is run with "fixed" rejection, a rejection value can be manually entered in this box.



Residual RMS– The Residual RMS box contains information about the global image closure for all the pictures. Use the up and down arrow keys to view the other entries in the information box.

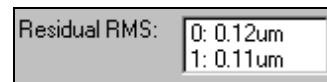

The Residual RMS values are your best indication of how things are going within the bundle. If the bundle is converging, the RMS values should be getting smaller. If the RMS is getting larger or oscillating, then the Bundle may be diverging. This may indicate a more serious problem with the network.

Pictures – The Picture section contains information about the images in the project. The total number of images along with the number of bad and weak images is displayed. Press the **More** button for more information about the Pictures. Refer to the [Bundle Statistics](#) section for more information on the **More** command in the Picture section.

Pictures

Total:	8
Weak:	0
Bad:	0

More...

Points – The Points section contains information about the points in the project. The total number of points along with the number of bad and weak points is displayed. The number of Two Ray points is also displayed. A Two Ray point is any point that only has two observations to it. Press the **More** button for more information about the Points. Refer to the [Bundle Statistics](#) section for more information on the **More** command in the Points section.

Points

Total:	330
Weak:	10
Bad:	0
Two Ray:	1

More...

Scales – The Scales section contains information about the scale bars in the project. The total number of scales along with the number of bad and weak points is displayed. Press the **More** button for more information about the Scale Bars. Refer to the [Bundle Statistics](#) section for more information on the **More** command in the Scales section.

Scales [inches]

Total:	2
Weak:	0
Bad:	0
RMS:	0.0006

More...

Camera – Click the **More** button to view the camera calibration information. Press the **More** button in the Camera Summary to view the additional calibration parameters

Cameras

More...

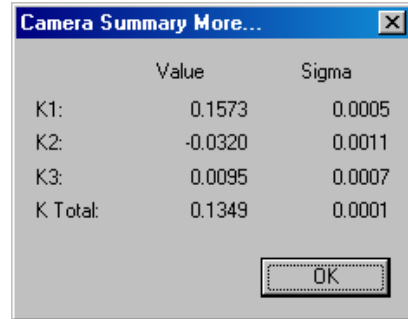
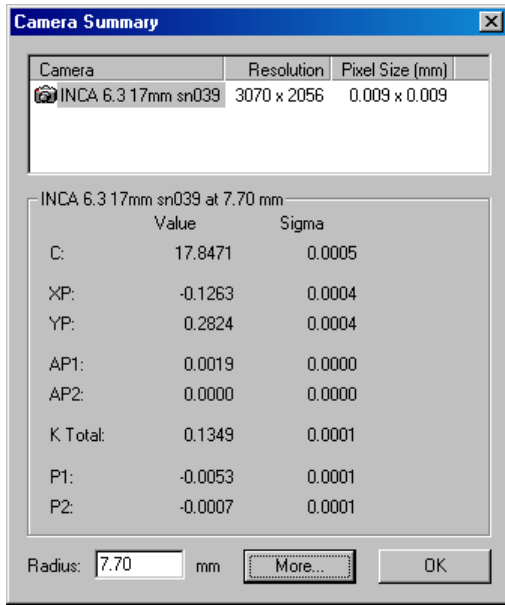

Control– The control box displays the number of control points in the bundle. Control points are held fixed in the bundle process and are usually used when there is good external control available.

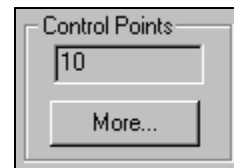

To create control, import the control point into the Design folder of the current driver. Open the Design folder and list the points. To create the control points, highlight the points you wish to mark. Right click over the points and select the **Control** option. Points marked as control will be displayed with a different icon. Control points are shown in the adjacent image.

	CONTROL1	3.7352
	CONTROL2	3.4914
	CONTROL3	3.2584
	CONTROL4	3.0229



Points must be in the Design folder to be set as control.

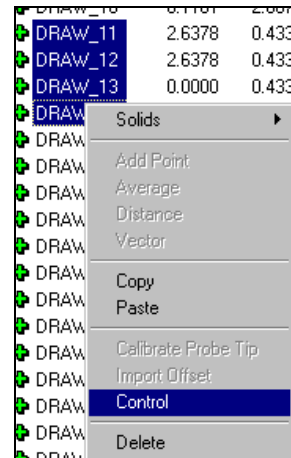

Click the **More** button to view the Control Point Summary.

Points	DX	DY	DZ
+ CONTROL1	0.001091	-0.01092	0.0003601
+ CONTROL2	0.00326	-0.01186	-0.00133
+ CONTROL3	0.003978	-0.01198	-0.002526
+ CONTROL4	0.003555	-0.01151	-0.002889
+ CONTROL5	0.002021	-0.01055	-0.002644
+ CONTROL6	-9.574e-005	-0.009039	-0.002569
+ CONTROL7	-0.0009235	-0.008033	-0.002991
+ CONTROL8	0.0004553	-0.008327	-0.003864

Accuracy – The accuracy box displays information about the Bundle result. The bundle units are listed in the brackets at the top.

Accuracy [inches]

RMS: X [0.0005] Y [0.0003] Z [0.0003]

Max: X [0.0017] Y [0.0011] Z [0.0015]

More... Points over limit: [10]

Plan Quality Factor: [1.01]

RMS of Measurements: [0.11um]

RMS X, Y, Z – The RMS is the Root Mean Square and is computed using the standard deviations of all the points.

Max X, Y, Z – The Max boxes display the maximum standard deviation value in X, Y and Z.

Points over limit – The Points over limit box displays the number of points above a certain limit. This limit value is set in the GSI32.ini file. Refer to the [GSI32.ini](#) section for more information.

If **More** is pressed then all the points over the limit are listed with their respective standard deviations. The Accuracy Limit used is also displayed at the top of the dialog.

Accuracy Limit: 0.0020 inches

Points	sx	sy	sz
+ AUTOBAR1	[0.0099]	0.0011	[0.0033]
+ AUTOBAR2	[0.0233]	[0.0086]	0.0012
+ AUTOBAR3	[0.0367]	[0.0134]	0.0016
+ AUTOBAR4	[0.0310]	[0.0083]	0.0019
+ AUTOBAR5	[0.0192]	[0.0025]	[0.0034]
+ AUTOBAR6	[0.0292]	[0.0095]	0.0012
+ CODE41	[0.1197]	[0.0282]	[0.0095]
+ CODE75	[0.0977]	[0.0571]	[0.0216]

Plan Quality Factor – The plan quality factor is a global measure of how good the network was. Typically, the Plan Quality Factor should be between 1-2. Values exceeding 2 indicate less than ideal geometry or overlap, or a poor calibration.

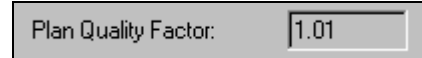

Plan Quality Factor: 1.01

RMS of Measurement - The RMS box displays the final global image closure for all the pictures. The RMS of measurements indicates the quality of the measurement. The lower the number, the better the measurement accuracy.

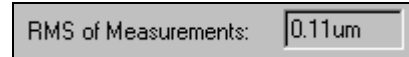

RMS of Measurements: 0.11um

A number of 0.40µm or less is typical. A larger number could be caused by many problems including:

1. A dirty lens. It is important to keep the lens clean and dry.
2. Dirty targets. Targets should be kept clean and dry.
3. Deformation of the object. The measured object must not change shape during the photography. This includes any artifacts (AutoBar, scale bars, etc.) attached to the object.
4. Extremely overexposed or underexposed targets.

Initial Bundle – When checked, an Initial Bundle is run instead of a full Bundle. In an Initial Bundle, the camera calibration parameters are held fixed.

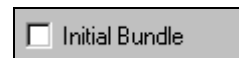

Initial Bundle



Setup Save Info. Start Reject Accept

Setup - The **Setup** button will take you directly to the Bundle Setup dialog. In previous versions of V-STARS, you had to exit the Bundle to make changes to the setup. For more information on the Bundle Setup, please refer to the section on the [Bundle Setup](#).

Save Info - The **Save Info** button will save the bundle summary dialog's information into a text file. This is particularly useful if you wish to review the Bundle Summary later or include the summary in a report.

A typical Bundle summary is shown below:

Bundle Dialog Information

Status: Bundle Converged after 2 Iterations
Current Point:
Rejection Limit: 0.86um
Residual RMS:
0: 0.22um
1: 0.22um
2: 0.22um

Pictures

Total: 19
Weak: 0
Bad: 0

Points

Total: 175
Weak: 0
Bad: 0
Two Ray: 0

Scales

Total: 0
Weak: 0
Bad: 0
RMS: N/A

Control Points

Control Points: N/A

Accuracy

RMS:
X: 0.019
Y: 0.008
Z: 0.009
Max:
X: 0.039
Y: 0.014
Z: 0.017
Points over limit: 0
Plan Quality Factor: 1.05
RMS of Measurements: 0.22um

Start – Press the **Start** Button to commence the Bundle process. Once Started a **Stop** button will appear. When stopped the dialog buttons will change as shown in the adjacent dialog.

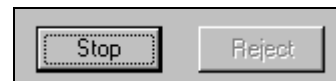

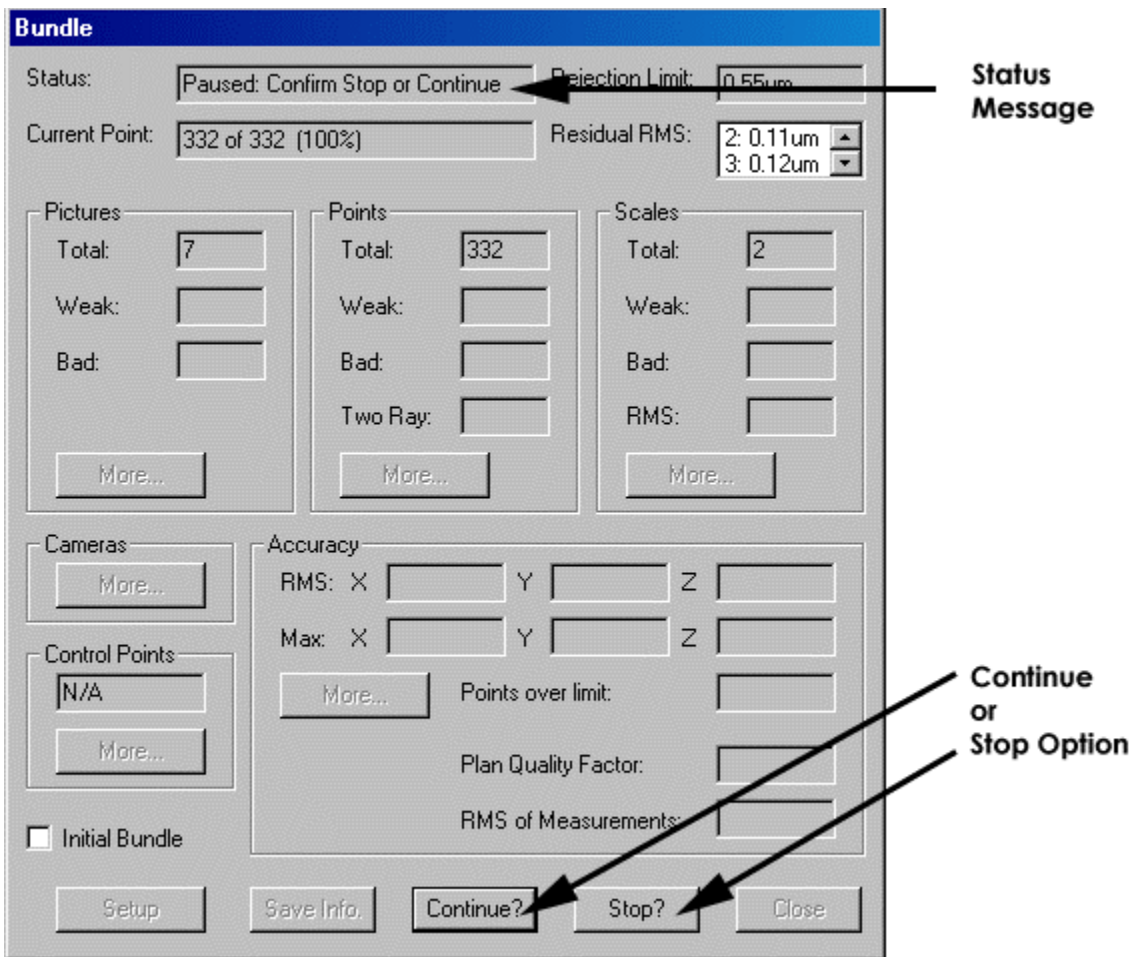

Press **Continue?** to continue from where the bundle stopped, or **Stop?** to stop the bundle. If **Stop?** is pressed again the following dialog appears.

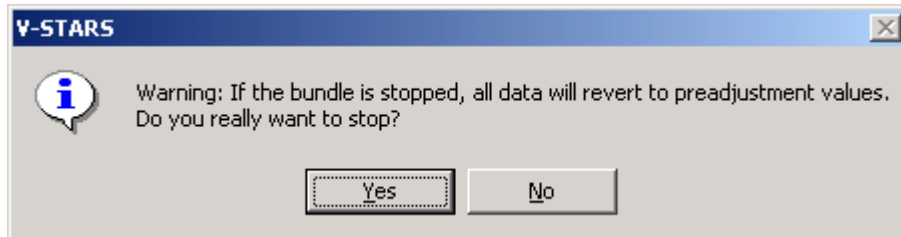

Press **Yes** to stop the bundle and revert to its original starting values. Press **No** to continue the Bundle process.

Reject – once the Bundle has converged, press the **Reject** button to reject the bundle and reset the values to their pre-bundle state.

Accept - Once the Bundle has converged, press the **Accept** button to accept the bundle close the bundle dialog.

Bundle Setup

The **Bundle Setup** command opens the **Bundle Setup** dialog. The dialog is shown below.

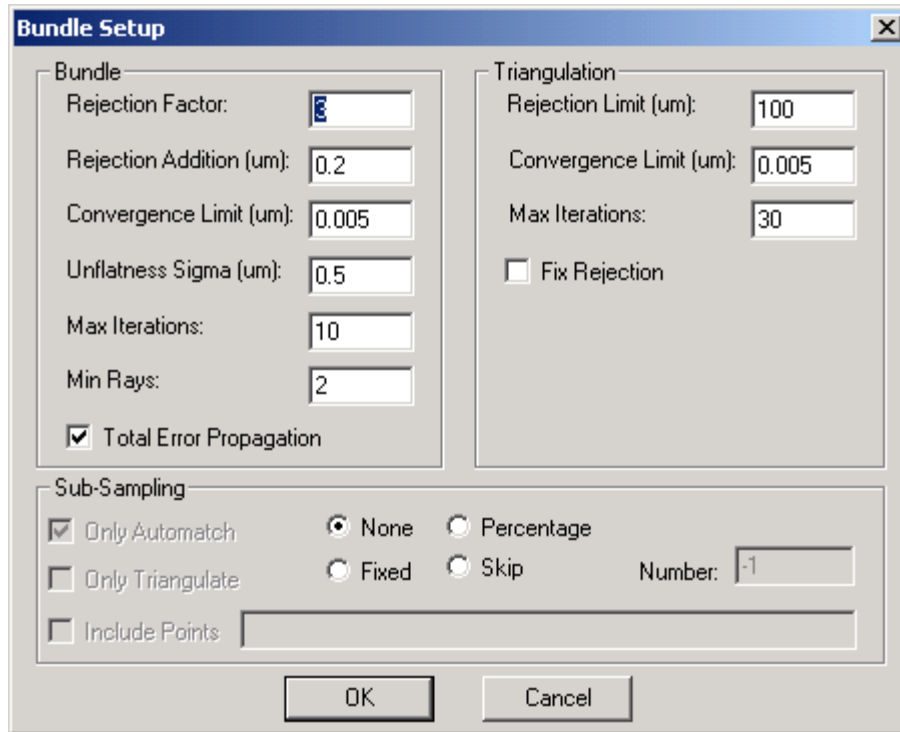

The Bundle Setup dialog is divided into three parts. They are Bundle, Triangulation and Sub-Sampling. For the most part, you don't need to worry about changing the setup values. In fact, it is probably advisable not to change the Bundle and Triangulation section values at all.

Bundle

Rejection Limit

The Rejection Limit for each iteration (in microns) of the bundle is calculated by multiplying the RMS of the previous iteration by the rejection factor and adding the rejection addition.

Convergence Limit

The bundle converges and stops when the RMS of the residuals between two successive iterations is less than this value (in microns).

Unflatness Sigma

Accounts for influence of unflatness of sensor on accuracy. Value is in microns.

- Maximum Iterations** If the bundle has not converged, it stops after this number of iterations. Pressing the **Start** button will re-start the bundle at the next iteration.
- Minimum Rays** Minimum number of rays for a point to be included in the bundle.
- Total Error Propagation** If checked the total accuracy estimates for points in the bundle is calculated. If unchecked, only the limiting accuracy estimates are calculated.
- The Total accuracy estimates take more time, but are more accurate. The bundle's Plan Quality Factor cannot be calculated unless this box is checked.

Triangulation

- Rejection Limit** The Rejection Limit for each iteration (in microns) of the triangulation is calculated by multiplying the RMS of the previous iteration by the rejection factor and adding the rejection addition.
- Convergence Limit** The triangulation converges and stops when the RMS of the residuals between two successive iterations is less than this value (in microns).
- Maximum Iterations** Maximum number of Triangulation iterations.
- Fixed Rejection** If checked the triangulation rejection limit is fixed. If unchecked, the rejection limit is allowed to adjust.

Sub-Sampling

Sub-sampling is used to speed up the bundling of projects with many points. The four main Sub-Sampling options as described below.

None - when selected the Sub-Sampling will be disabled. In this mode, all the input areas are grayed out. All points will be used in the bundle adjustment.

Percent - The Percent option will use the specified percentage of the total number of sub-samplable points. This percentage is set in the **Number** input box.

Fixed - The Fixed option will use a fixed number of the total sub-samplable points. The number of points is set in the **Number** input box.

Skip - The Skip option will select every n^{th} sub-samplable point as it is encountered. Once again, n is defined in the **Number** input box.

Sampling Options

None Percent

Fixed Skip Number: 50

 By default the number input box is set to -1. Please enter an appropriate number once you have decided on the type of sub-sampling you wish to do.

 In sub-sampling, the software selects the points from the set of sub-samplable points by selecting every n^{th} point in the measurement (points are ordered alphanumerically by label); n is determined by the sub-sampling option chosen above.

If a sub-sampling option is selected, additional options are available. These are:

Triangulate Only or **Re-Bundle** - When the bundle solution using the sub-sampled set of points is complete, you have two choices. You can select **Triangulate Only** to use that solution to triangulate all the points.

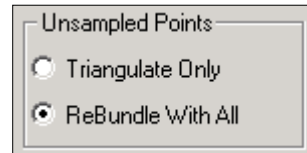

The screenshot shows a dialog box titled "Unsampled Points" with two radio button options: "Triangulate Only" and "ReBundle With All". The "ReBundle With All" option is selected.

Alternatively, by selecting **ReBundle with All**, you can automatically re-run the bundle adjustment using all the points and use that solution to triangulate all the points. The first choice is faster; the second choice is more accurate (however, the accuracy improvement should be negligible if you have selected a good sub-sample set; see  below).

AutoMatch Only – When checked, only AutoMatched points will be sub-sampled. AutoMatched points begin with the prefix TARGET. All other points will be included in the bundle adjustment. When unchecked, all points (except codes, nuggets, and control, see above) will be sub-sampled.

Include Points – The include points option will include in the bundle any of the points that are listed in



The screenshot shows a dialog box titled "Point Sets" with two checked checkboxes: "AutoMatched Only" and "Include Points". The "Include Points" checkbox has a text input field containing the string "S1,S2,DE23>DE34".

the adjacent text box. The text box supports the "*" and "?" wildcards. Multiple strings can be entered; a space or a comma must separate them; case does not matter. A range of points can be specified by separating them with the ">" symbol (i.e. "line1 > line120" would include all points with labels from line1 to line120 inclusive); spaces are allowed between the > symbol and the two labels.

 You should be careful when sub-sampling. Make sure there are still enough points in the bundle adjustment to get a good solution. This means you should have at least 20 well-distributed points (preferably 40) in each picture, and at least 50 well-distributed points (preferably 100) total. When in doubt about the number of points or whether they are well distributed, include more points. Also, make sure that any tie and/or fill points you have used for the measurement are included in the sub-sampled data set.

Bundle Statistics

Introduction

After a bundle, V-STARS will examine the data, classify the pictures, points, and scale bars as good, weak, or bad based on user specified criteria. The criteria will in no way effect the bundle results and are only used to indicate to you the quality of the measurement.

Criteria Tests

Four basic tests are performed on the data. Each test has its own set of weak criteria and bad criteria. A picture or point is classified good, weak or bad depending upon which criteria it fails (or passes). If the picture or point passed all criteria then it is classified good. If it fails the weak criteria but not the bad criteria then it is classified weak. If it fails the bad criteria then it is classified bad. Scale bars are tested the same way but only one point has to fail the criteria for the entire scale bar to be classified weak or bad. The point values that fail a criteria are marked with either a pair of * * to denote failure of a BAD criteria or [] to denote failure of a WEAK criteria. The values are enclosed within the asterix (* *) or the brackets ([]).

The Number Test (#)

This test examines the number of points in a picture and the number of rays on a point. The default limits are described in [GSI32.ini](#) Settings description.

The Percentage Test (%)

This test examines the percentage of points accepted in a picture and the percentage of rays accepted on a point. The default limits are described in [GSI32.ini](#) Settings description.

The Value Test (V)

This test examines the sigma X, sigma Y, sigma Z, sigma azimuth, sigma elevation and sigma roll of a picture and the sigma X, sigma Y and sigma Z of a point. If the value is greater than the criteria then this test has failed. The default limits are described in [GSI32.ini](#) Settings description.

The Median Test (M)

This test examines the sigma X, sigma Y, sigma Z, sigma azimuth, sigma elevation and sigma roll of a picture and the sigma X, sigma Y and sigma Z of a point. If the value is greater than the criteria multiplied by the median of all the like values then this test has failed. The default limits are described in [GSI32.ini](#) Settings description.



Icons

The pictures, points and scale bars will be associated with one of the following icons depending upon the classification that V-STARS assigns. Refer to the [Icons](#) section for a full listing of the V-STARS icons



Pictures

-  Good Picture
-  Weak Picture
-  Bad Picture

Points

-  Good Point
-  Weak Point
-  Bad Point









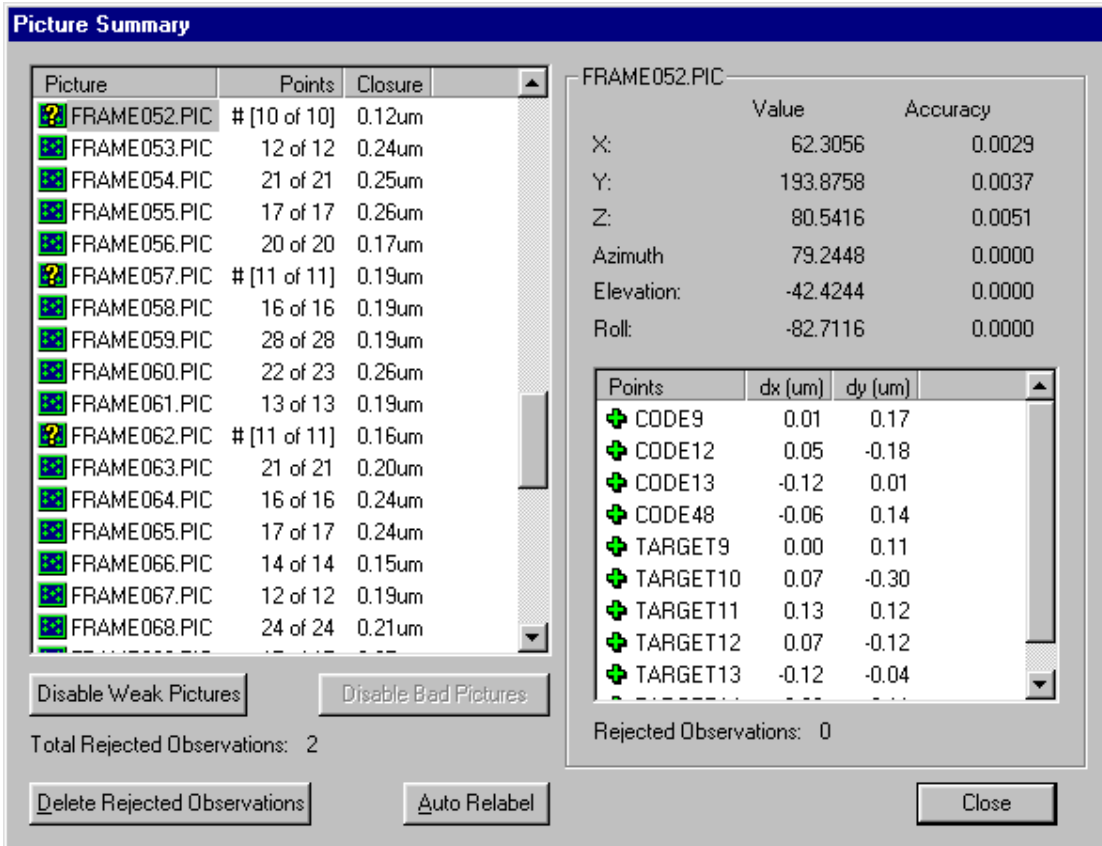







Scale Bars

-  Good Scale Bar
-  Weak Scale Bar
-  Bad Scale Bar









Viewing Picture Summary

The statistics are viewed by selecting the **More** buttons from the Bundle dialog. If a picture or point is weak then the reason it is weak will be highlighted with brackets and preceded by a #, %, V or M, indicating that it failed the number, percentage, value or median tests respectively. If a picture or point is bad then the reason it is bad will be highlighted with asterisks and preceded by a #, %, V or M, indicating which test it failed. Below is the Picture Summary dialog after a bundle.



Picture	Points	Closure
 FRAME052.PIC	# [10 of 10]	0.12um
 FRAME053.PIC	12 of 12	0.24um
 FRAME054.PIC	21 of 21	0.25um
 FRAME055.PIC	17 of 17	0.26um
 FRAME056.PIC	20 of 20	0.17um
 FRAME057.PIC	# [11 of 11]	0.19um
 FRAME058.PIC	16 of 16	0.19um
 FRAME059.PIC	28 of 28	0.19um
 FRAME060.PIC	22 of 23	0.26um
 FRAME061.PIC	13 of 13	0.19um
 FRAME062.PIC	# [11 of 11]	0.16um
 FRAME063.PIC	21 of 21	0.20um
 FRAME064.PIC	16 of 16	0.24um
 FRAME065.PIC	17 of 17	0.24um
 FRAME066.PIC	14 of 14	0.15um
 FRAME067.PIC	12 of 12	0.19um
 FRAME068.PIC	24 of 24	0.21um

FRAME052.PIC		
	Value	Accuracy
X:	62.3056	0.0029
Y:	193.8758	0.0037
Z:	80.5416	0.0051
Azimuth	79.2448	0.0000
Elevation:	-42.4244	0.0000
Roll:	-82.7116	0.0000

Points	dx (um)	dy (um)
 CODE9	0.01	0.17
 CODE12	0.05	-0.18
 CODE13	-0.12	0.01
 CODE48	-0.06	0.14
 TARGET9	0.00	0.11
 TARGET10	0.07	-0.30
 TARGET11	0.13	0.12
 TARGET12	0.07	-0.12
 TARGET13	-0.12	-0.04

Total Rejected Observations: 2

Rejected Observations: 0

FRAME052, FRAME57 and FRAME062 are classified as weak (2). They are weak because they all failed the number test using the weak criteria (note the brackets around the number of points).

Viewing Points Summary

The Points Summary dialog contains a great deal of statistical data related to the bundle. The following information is provided in the dialog.

Points	Point Label for the point.
Sigma X	The final standard deviation in the X direction for the point
Sigma Y	The final standard deviation in the Y direction for the point
Sigma Z	The final standard deviation in the Z direction for the point
RSS	RSS stands for square Root of the Sum of Squares. The formula for the RSS accuracy of a point is:

$$RSS = \sqrt{\sigma_X^2 + \sigma_Y^2 + \sigma_Z^2}$$

The RSS is a useful statistic that combines the separate coordinate accuracy estimates into one meaningful quantity. It represents the accuracy estimate of the distance of the measured point from its true value.

Rays	The number of rays the point is seen by.
Closure	The overall image space closure for the point.

Below is a typical Point Summary dialog after a bundle.

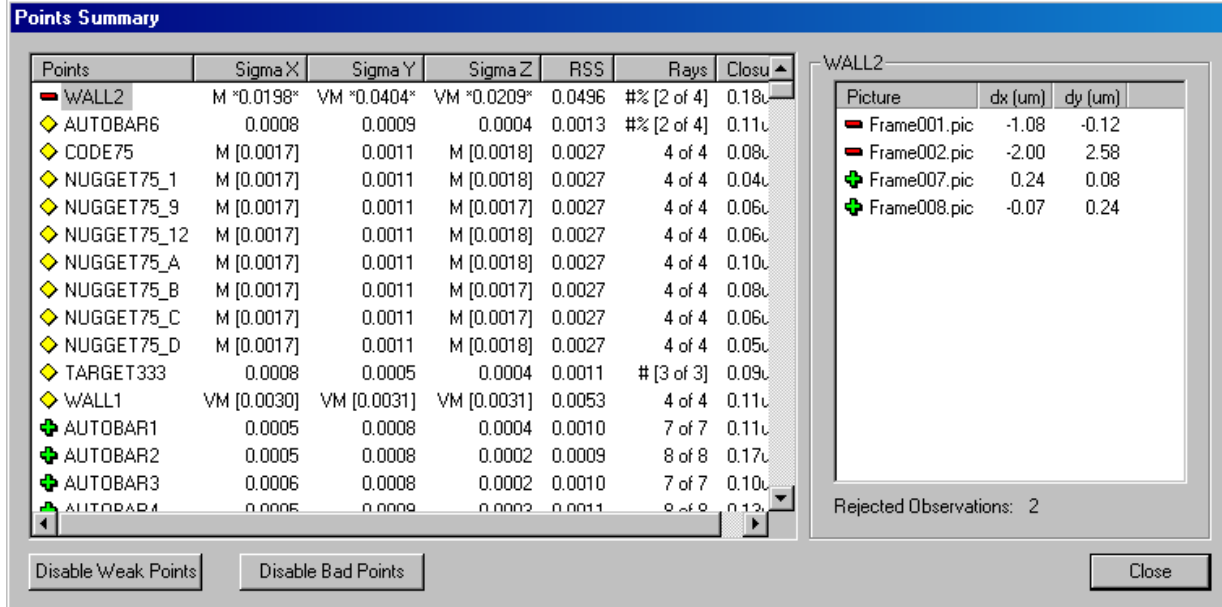

WALL2 is classified bad (■) because it failed the percentage and number test. Note that it also failed the sigma Y and sigma Z value and the sigma X, sigma Y and sigma Z median tests. The rejected observations for WALL2 are shown in the frame on the right of the dialog. The majority of the points with the yellow icons are classified weak (◆) because they failed the sigma X and sigma Z median test. Note that WALL1 also failed the sigma X, sigma Y, sigma Z value and median tests. TARGET333 is weak because it failed the weak number test.

Viewing Scale Summary

Adjacent is the Scale Bar Summary dialog after a bundle. Bar1 is classified weak because point 122 failed the sigma Y value test using the weak criteria. Note that point 121 passed all the tests but the scale bar is still classified weak because only one point has to fail in order for the scale bar to fail.

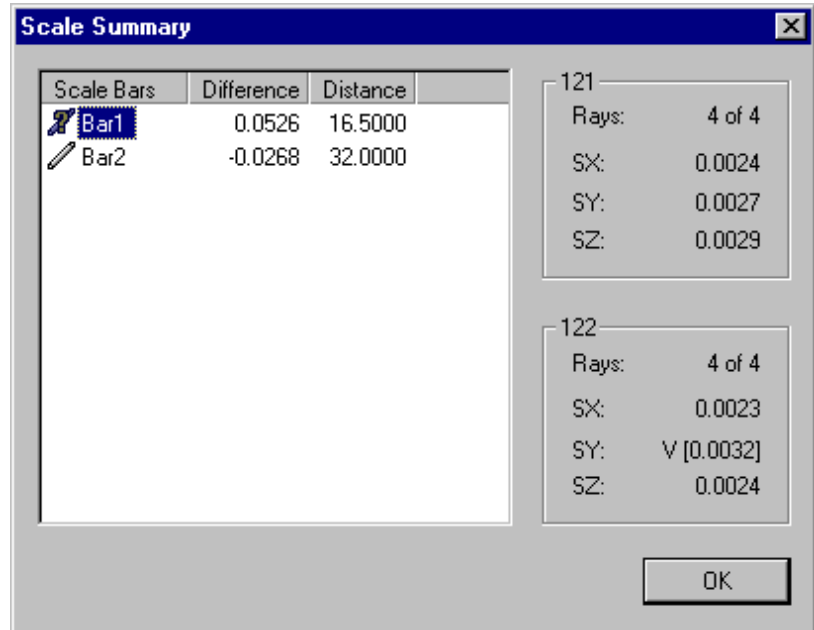

Bundle Automatic Scale Rejection

The bundle can automatically reject scale bars based on criteria defined in the GSI32.ini file. Criteria are provided for rejecting scale bars with deviations that are large relative to the other scale bars (as defined by the RMS of their deviations), or larger than a fixed value.

By default, this feature is disabled (-1). The following lines in the GSI32.ini file control the scale bar rejection.

<code>scalebar rejection factor =-1</code>	< 0 : Relative scale bar rejection disabled. > 0 : Multiply RMS of all scale bars by this factor to get the rejection limit.
<code>scalebar rejection value=-1</code>	< 0: Absolute scale bar rejection disabled. > 0: Any scale bar deviation with an absolute value greater than this value is rejected.  The units for this value are defined by the "accuracy units" variable in the GSI32.INI file.

GSI32.INI File Default Settings

All values listed are default values.

Bundle General

This section contains items related to the general operation of the bundle. Many of these can also be set in the Bundle Setup dialog.

GSI32.ini Entry	Comment
rejection factor=3.0 rejection addition=0.0002	Rejection level for each iteration (in mm) of the bundle is calculated by multiplying the RMS of the previous iteration by the rejection factor and adding the rejection addition. The fixed rejection flag value must be false to enable these values.
convergence limit=0.000005	The bundle converges and stops when the RMS of the residuals between two successive iterations is less than this value (in mm).
maximum iterations=10	If the bundle has not converged, it stops after this number of iterations. Pressing the Start button will re-start the bundle at the 11 th iteration.
total error propagation=FALSE	TRUE= calculate total accuracy estimates for points in the bundle. FALSE= calculate only the limiting accuracy estimates. The Total accuracy estimates take more time but are more accurate. The bundle's Plan Quality Factor cannot be calculated unless this value is True.
minimum rays=2	Minimum number of rays for a point to be included in the bundle.
minimum automatched rays=3	Minimum number of rays an automatched point must have in order to be included in the bundle.
triangulation rejection limit=0.1	Triangulation rejection limit (mm).
triangulation initial rejection limit=0.05	Initial triangulation rejection limit (mm).
triangulation convergence limit=0.000005	Triangulation convergence limit (mm).

GSI32.ini Entry	Comment
<pre>triangulation maximum iterations=30 resection rejection limit=0.002 auto resection rejection=FALSE</pre>	<p>Maximum triangulation iterations to perform.</p> <p>Resection rejection limit (mm).</p> <p>TRUE = Reject resection points that are > RMS resection rejection factor. FALSE= Reject resection points that are > resection rejection limit.</p>
<pre>resection rejection factor=3</pre>	<p>Multiplier used to calculate the resection rejection limit.</p>
<pre>resection convergence limit=0.00001</pre>	<p>The resection converges and stops when the RMS of the residuals between two successive iterations is less than this value (in mm).</p>
<pre>resection maximum iterations=30</pre>	<p>If the resection has not converged, it stops after this number of iterations.</p>
<pre>confidence factor=1.0</pre>	<p>All bundle estimated accuracies for points (sigmas) are multiplied by this confidence factor (allows estimates to be scaled to reflect actual accuracies achieved). If =1, then estimated accuracies are not changed.</p>
<pre>unflatness sigma=0.0005</pre>	<p>Accounts for influence of unflatness of sensor on accuracy. Value is in mm.</p>
<pre>fixed rejection limit=FALSE</pre>	<p>TRUE = Adjust bundle rejection limit using rejection factor and rejection addition. FALSE = Use a fixed rejection limit for the bundle. Initially, the bundle rejection limit is 10 times the largest RMS of the residuals of all the resected pictures.</p>
<pre>weighted=FALSE</pre>	<p>TRUE = weight image sigmas for each point based on target size (not usually used) FALSE = use 0.0005 mm for the image sigmas.</p>
<pre>accuracy limit units=inches</pre>	<p>Units of the accuracy limit.</p>

GSI32.ini Entry	Comment
accuracy limit=0.002	If the accuracy estimate (sigma) for any of the three coordinates of a point is larger than this value, the point is over the accuracy limit. The count of these points is given in the Bundle Summary dialog. Details are available using the more button. A value < 0 disables this check.
write old input file=FALSE	If TRUE input.txt file is created
resection triangle goodness=-1	The resection triangle test is disabled.
impossibly close units=inches impossibly close distance=0.05	Used to merge automatched points that are in fact the same point. If, after the bundle converges, any points are found within this distance of each other, they are combined.  This is impossible for targets, but not for projected dots.
power user mode=TRUE	TRUE allows you to do things not normally allowed (run "singular" bundles, etc.)
subsample type=0	Set type of points to subsample. Set this value from the Bundle Setup dialog.
subsample number=10	Set subsample number. Set this value from the Bundle Setup dialog.
subsample only automatch=FALSE	TRUE = subsample all points, FALSE = subsample only Automatched points (TARGET# pts).
subsample only triangulate=FALSE	Subsample options. Set this value from the Bundle Setup dialog.
scalebar rejection factor=-1	-1 : Disabled
scalebar rejection addition=0	>0 : Factor to multiply scale bar RMS by Rejection level for each scale bar (in mm) is calculated by multiplying the RMS by the rejection factor and adding the rejection addition.
scalebar rejection value=-1	Absolute value at which the scale bar is rejected.

Bundle Weak Criteria

This section contains the values used to determine if a picture, point or scale bar is weak. To disable one of the tests change the value to -1. The criteria below are used for general bundle adjustments. Weak data are summarized in the bundle dialog summary, and weak values are flagged in the listings that are accessed by pressing the **More** button in the bundle summary dialog. Weak criteria are meant to identify things that are probably OK but may need to be looked at.

GSI32.ini Entry	Comment
<code>units = inches</code>	Units used for all the dimensional values in this section (such as coordinate sigmas)
<code>picture number of points = 12</code>	Picture number test. A picture is weak if its number of accepted points is less than this value.
<code>picture percentage of points = 80.0</code>	Picture percentage test. A picture is weak if its number of accepted points is less than this percentage.
<code>picture sigma x = -1.0</code> <code>picture sigma y = -1.0</code> <code>picture sigma z = -1.0</code> <code>picture sigma azimuth = -1.0</code> <code>picture sigma elevation = -1.0</code> <code>picture sigma roll = -1.0</code>	Picture value test. A picture is weak if any of its accuracy estimates (sigmas) are greater than the specified value. If the value is < 0 then the test is disabled. These checks are usually disabled.
<code>picture sigma median x = -1.0</code> <code>picture sigma median y = -1.0</code> <code>picture sigma median z = -1.0</code> <code>picture sigma median azimuth = -1.0</code> <code>picture sigma median elevation = -1.0</code> <code>picture sigma median roll = -1.0</code>	A picture is weak if any of the accuracy estimates (sigmas) are greater than the specified value multiplied by the median sigma for all the pictures. This checks if a picture has weak accuracy compared to the "average" picture. A value < 0 means the weakness check is disabled. These checks are usually disabled.

GSI32.ini Entry	Comment
point number of rays = 4	Point number test. A point is weak if its number of accepted image measurements is less than this value.
point percentage of rays = 75.0	Point percentage test. A point is weak if its percentage of accepted image measurements is less than this value.
point sigma x = 0.002 point sigma y = 0.002 point sigma z = 0.002	A point is weak if any of its 3 accuracy estimates (sigmas) are greater than the specified value.
point sigma median x = 3.0 point sigma median y = 3.0 point sigma median z = 3.0	This check compares the accuracy to a fixed value. A value < 0 means the weakness check is disabled.
scalebar number of rays = 4	Scale bar number test. A scalebar is weak if the number of accepted image measurements for either of its points.
scalebar percentage of rays = 75.0	Scale bar percentage test. A scalebar is weak if its percentage of accepted image measurements for either of its points is less than this value.
scalebar sigma x = 0.002 scalebar sigma y = 0.002 scalebar sigma z = 0.002	A scalebar is weak if any of the three accuracy estimates (sigmas) for either of its points are greater than the specified value. This check compares the accuracy to a fixed value. A value < 0 means the weakness check is disabled.
scalebar sigma median x = 2.0 scalebar sigma median y = 2.0 scalebar sigma median z = 2.0	A scalebar is weak if any of the three accuracy estimates (sigmas) for either of its points are greater than the specified value multiplied by the median sigma for all the points. This checks if a scalebar has weak accuracy compared to the "average" scalebar. A value < 0 means the weakness check is disabled.

Bundle Bad Criteria

This section contains the values used to determine if a picture, point or scale bar is bad. To disable one of the tests change the value to -1. The criteria below are used for general bundle adjustments. Bad data are summarized in the bundle dialog summary, and bad values are flagged in the listings that are accessed by pressing the **More** button in the bundle summary dialog. Bad criteria are meant to identify things that are probably going to have to be removed from the Bundle.

GS132.ini Entry	Comment
<code>units = inches</code>	Units used for all the dimensional values in this section (such as coordinate sigmas)
<code>picture number of points = 6</code>	Picture number test. A picture is bad if its number of accepted points is less than this value.
<code>picture percentage of points = 50.0</code>	Picture percentage test. A picture is bad if its number of accepted points is less than this percentage.
<code>picture sigma x = -1.0</code> <code>picture sigma y = -1.0</code> <code>picture sigma z = -1.0</code> <code>picture sigma azimuth = -1.0</code> <code>picture sigma elevation = -1.0</code> <code>picture sigma roll = -1.0</code>	Picture value test. A picture is bad if any of its accuracy estimates (sigmas) are greater than the specified value. If the value is < 0 then the test is disabled. These checks are usually disabled.
<code>picture sigma median x = -1.0</code> <code>picture sigma median y = -1.0</code> <code>picture sigma median z = -1.0</code> <code>picture sigma median azimuth = -1.0</code> <code>picture sigma median elevation = -1.0</code> <code>picture sigma median roll = -1.0</code>	A picture is bad if any of the accuracy estimates (sigmas) are greater than the specified value multiplied by the median sigma for all the pictures. This checks if a picture has bad accuracy compared to the "average" picture. A value < 0 means the badness check is disabled. These checks are usually disabled.
<code>point number of rays = 2</code>	Point number test. A point is bad if its number of accepted image measurements is less than this value.
<code>point percentage of rays = 50.0</code>	Point percentage test. A point is bad if its percentage of accepted image measurements is less than this value.

GSI32.ini Entry	Comment
point sigma x = 0.02 point sigma y = 0.02 point sigma z = 0.02	A point is bad if any of its 3 accuracy estimates (sigmas) are greater than the specified value.
point sigma median x = 10.0 point sigma median y = 10.0 point sigma median z = 10.0	This check compares the accuracy to a fixed value. A value < 0 means the badness check is disabled.
scalebar number of rays = 2	Scale bar number test. A scalebar is bad if the number of accepted image measurements for either of its points.
scalebar percentage of rays = 50.0	Scale bar percentage test. A scalebar is bad if its percentage of accepted image measurements for either of its points is less than this value.
scalebar sigma x = 0.02 scalebar sigma y = 0.02 scalebar sigma z = 0.02	A scalebar is bad if any of the three accuracy estimates (sigmas) for either of its points are greater than the specified value. This check compares the accuracy to a fixed value. A value < 0 means the badness check is disabled.
scalebar sigma median x = 5.0 scalebar sigma median y = 5.0 scalebar sigma median z = 5.0	A scalebar is bad if any of the three accuracy estimates (sigmas) for either of its points are greater than the specified value multiplied by the median sigma for all the points. This checks if a scalebar has bad accuracy compared to the "average" scalebar. A value < 0 means the badness check is disabled.

3D Viewer

Introduction

To help visualize your data, a graphical three-dimensional viewer is included in V-STARS. You can easily view your measured object from any perspective, and compare the measured results to design values. You can also transform the data into the design coordinate system before comparison. Several different types of transformations are possible. Simple measurements are also available with the viewer such as point-to-point distances, vector point calculations, and average point calculations. These are described in the [Basic Measurement Functions](#) Section of the manual.

Viewpoint

Viewpoint Manipulation

Viewpoint manipulation involves changing the position of the entire scene relative to your screen. The primary tool used to manipulate the scene is the mouse.

Using the mouse

The most common use of the mouse is to rotate the scene. To rotate the scene, click and hold the right mouse button and move the cursor. If the cursor is moved to the right, the scene will rotate to the right and if the cursor is moved to the left, the scene will rotate to the left. Likewise, if the cursor is moved up the scene will rotate up and if the cursor is moved down to scene will rotate down.

The sensitivity of the rotation is affected by the value of the Rotation Multiplier. This figure can be changed in the View Setup Dialog. Refer to the [View Setup](#) Section for more information.

Panning

To pan the scene, click and hold the right mouse button and move the cursor while also holding the  key down. If the cursor is moved to the right, left, up or down the scene will pan to the right, left, up or down.

Zooming





To zoom the scene, click and hold the right mouse button and move the cursor while also holding the  key down. If the cursor is moved up the scene will zoom out. If the cursor is moved down the scene will zoom in.

If you are using the Microsoft IntelliMouse and are running Windows NT 4.0 or later then, you may use the mouse wheel to pan and zoom the scene. To pan using the mouse wheel, click and hold the wheel and move the cursor. This will perform the same panning action described earlier. To zoom simply rotate the wheel. Rotating the wheel away from you will cause the scene to zoom out, and rotating the wheel towards you will cause the scene to zoom in.



The sensitivity of the pan and zoom is affected by the Translation Multiplier. Refer to the [View Setup](#) Section for more information on changing the Translation Multiplier.







Using the keyboard

Fitting

The most commonly used keyboard command is the Fit command. The Fit command will adjust the scene so that all the entities will fit onto the display. Press the  to perform a Fit. Three additional commands related to the Fit command are the Fit X, Fit Y and Fit Z commands. These commands will adjust the scene so you are looking down the negative X, Y, or Z-axis. Press the ,  and  keys to perform these actions. Once you are fitted to the axis, pressing the key again will adjust the scene so you look up the positive axis.





Rotating

To rotate the scene about the screen use the  and  arrow keys. Pressing the left arrow key will rotate the scene counter clockwise 1°. Pressing the right arrow key will rotate the scene clockwise 1°. If the  key is held while this operation is performed then the rotation amount is multiplied by 10.







To rotate the scene up, down, left and right hold the  key down while pressing the , , , and  arrow keys. The scene is rotated in 1° increments. If the  key is held while this operation is performed then the rotation amount is multiplied by 10.

The sensitivity of the rotation is affected by the value of the Rotation Multiplier. Refer to the [View Setup](#) Section for more information on changing the Rotation Multiplier.

Zooming

To zoom the scene use the  and  arrow keys. Pressing the  arrow will zoom in and pressing the  arrow will zoom out. If the  key is held while this operation is performed then the zoom amount is doubled.



Panning



To translate the scene up, down, left and right hold the  key down while pressing the , , , and  arrow keys. The scene is translated in one-unit increments. If the  key is held while this operation is performed then the translation amount is multiplied by 10.

The Translation Multiplier affects the sensitivity of the pan and zoom. Refer to the [View Setup](#) Section for more information on changing the Translation Multiplier.

Selection

Selection Types

There are two types of selection operations that can be performed using the 3D viewer: Single Selection and Multiple Selection. When performing a selection you may hold the  key down to add entities to the current selection. If the  key is not held down then current selections will be deselected.

If  is on, then the selection function is reversed. New selections will be added to the current selection by default and if the  key is held down then the current selections are deselected. To deselect the points, switch the  to off and click anywhere in the viewer.



Single Selection

To perform a single selection, position the cursor over a particular object and click the left mouse button. The selected object will be highlighted. If two objects lie on top of one another then both objects will be selected. Alternatively, a point can be selected by clicking and holding the left mouse button and moving the cursor. As you move the cursor, a rectangle will form. When you release the button, the points within the square will be selected.

Multiple Selection

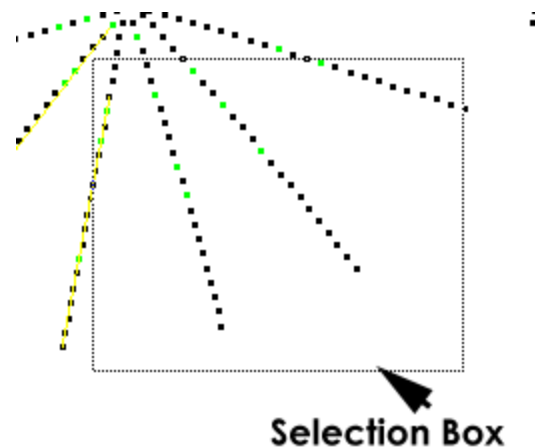
To perform a multiple selection, click and hold the left mouse button and move the cursor. As you move the cursor, a rectangle will form. When you release the left button, everything that lies entirely within that rectangle will be selected. Alternatively, hold

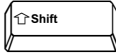

The  key and select multiple points or use the  feature described in the [Selection Types](#) section.

Identification

To identify an entity, position the cursor over the entity. If enabled, the Tool Tip window will pop up with information about the entity. If the Tool Tip window is disabled the information will appear in the lower left corner of the display. To enable or disable the Tool Tip, go to the second page of the View Setup dialog and check or uncheck the Tool Tip check box. Refer to the [View Setup](#) section for information on switching the Tool Tip on.

Measured Point
Label: TARGET86
X: 992.029
Y: -38.627
Z: -12.559

 The residual and measurement information is directly tied to the component vector options. For example, if you are only displaying the Delta X vector component then only the Delta X value will be displayed.

Delete and Rename



Delete

To delete objects you must first select them. Once selected, you may delete them by using the Delete command from the right click menu or by pressing the  key. You may also use the delete cursor to delete objects.

The delete cursor works the same as the standard selection cursor except when a selection is made the selected objects are deleted (you will be given a warning message before the deletion takes place).

 If the objects you are deleting are points and the data file is the current driver file then you may use the global delete cursor.

The global delete cursor behaves the same way it does when you are deleting points in a picture. All points selected will be removed from the driver file and from all pictures (you will be given a warning message before the deletion takes place).

Rename

To rename points from within the graphical view you must use the rename cursor.

The rename cursor works the same as the standard selection cursor except when a selection is made the selected objects are renamed to the current point label. When the rename cursor is active, you may use the keyboard to enter the current point label just as you would while editing a picture. The current point label is displayed in the lower left of the screen.

 If the data file is the current driver file then you may use the global rename cursor. The global rename cursor behaves the same way it does when you are renaming points in a picture. All points selected will be renamed in the driver file and in all pictures.

 When renaming points in the graphical view you cannot use the line following command.

Display Options

View Setup

Many display options are accessed through the **View Setup** dialog. To access the **View Setup** dialog select **View Setup** from the right click menu or press the  key

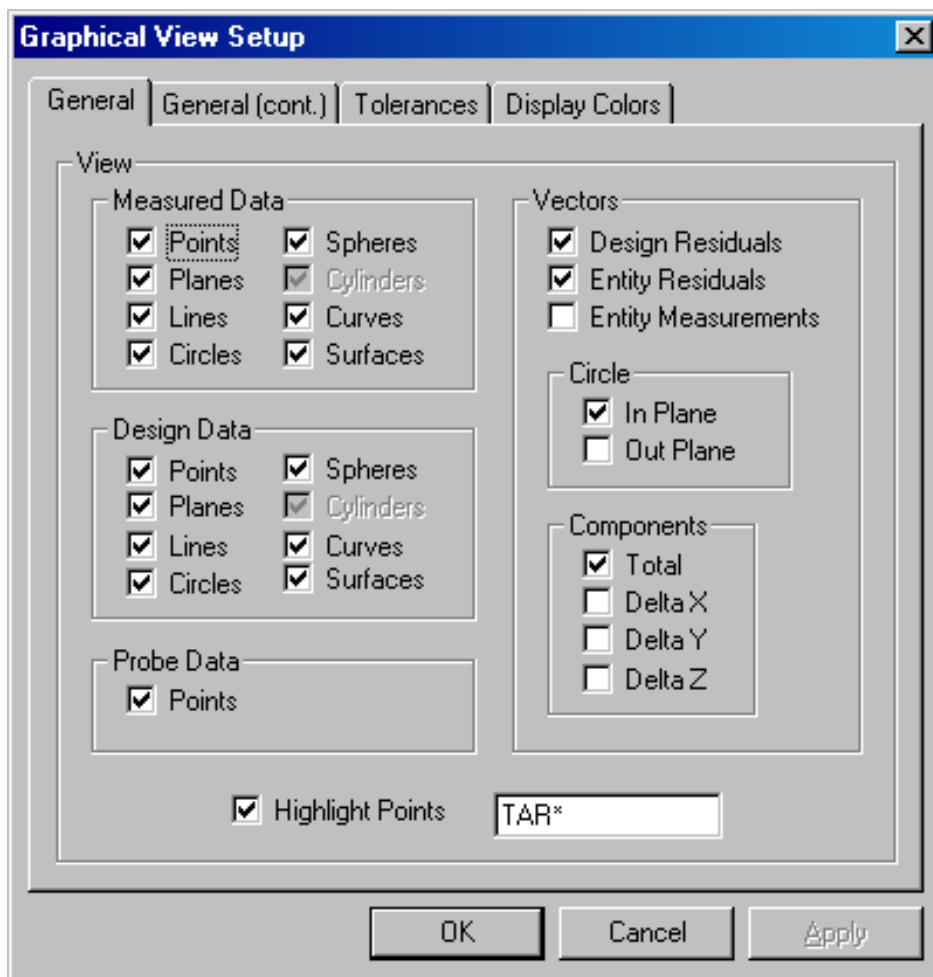

General

View – Measured Data

When the measured items (entities) listed are checked they are visible in the graphical view. To switch off a particular entity simply uncheck the relevant box and press the **Apply** button or **OK**. Refer to the Solids section of the manual for more information on the different entities.



The Cylinder option is dimmed, as this entity has not been incorporated into V-STARS at this time.

View – Design Data

When the design items (entities) listed are checked they are visible in the graphical view. To switch off a particular entity simply uncheck the relevant box and press the **Apply** button or **OK**.

View – Probe Data

If the project includes data that has been collected using a probe it will be visible if this option is checked.

Vectors – Design Residuals

When checked, the measured to design data residuals are shown. Design Residuals are the difference vectors between measured and design data.

Vectors – Entity Residuals

When checked, the residuals for any entity measurements are shown. Entity Residuals are the difference vectors between an entity and the points used to create it.

Vectors – Entity Measurements

When checked the residuals for any measurement made to an entity is shown. Entity Measurements are the difference vectors between an entity and the points that were measured to it after it was created. Entity Measurements are displayed as dotted lines, whereas Design Residuals and Entity Residuals are displayed as solid lines.

Circle – In Plane

When checked the in-plane residuals for a circle are shown. The Circle In Plane check box controls the in plane circle vectors and Circle Out Plane controls the out of plane vectors. The in plane vector is the component of the circle vector that is parallel to the plane of the circle. Refer to the Solids section of this manual for more information on Circles.

Circle – Out Plane



When checked the out plane residuals for a circle are shown. The out plane vector is the component of the circle vector that is perpendicular to the plane of the circle.

Components – Total

The Components group of check box allows you to choose which type of vector is displayed. When checked the total component of the vector is shown. The Total vector represents all the individual XYZ components. The total vector can be switched on or off using the  key.

Components - XYZ

Check the appropriate box to view the individual XYZ vector residuals. If Delta X is checked then the X component of the vector is displayed. If Delta Y is checked then the Y component of the vector is displayed. If Delta Z is checked then the Z component of the vector is displayed.

The vectors can also be switched on or off using the    keys for the X, Y and Z components respectively.



Highlight Points

The Highlight Points text box supports the "*" and "?" wildcards. Multiple strings can be entered; a space or a comma must separate them; case does not matter. A range of points can be specified by separating them with the ">" symbol (i.e. "line1 > line120" would highlight all points with labels from line1 to line120 inclusive); spaces are allowed between the > symbol and the two labels. By default, highlighted points are displayed with a yellow marker. The highlight color can be changed in the **Display Colors** section of the **Graphical View Setup**.

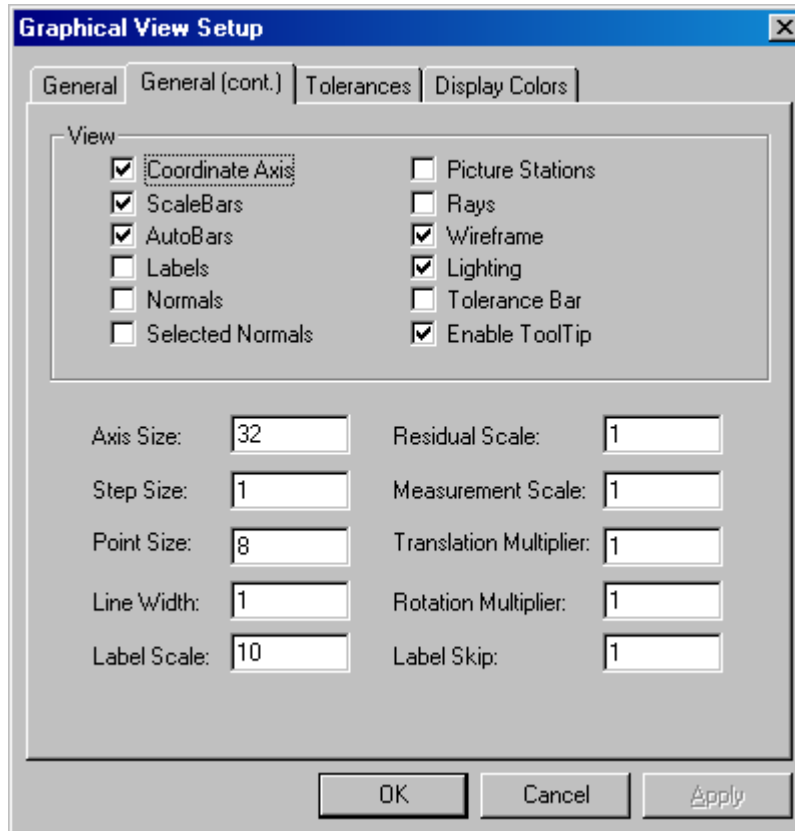
General (cont.)



View – Coordinate Axis

Switch on the coordinate axis in the graphical view. The size of the axis can be controlled using the Axis Size input box or the  or  keys.

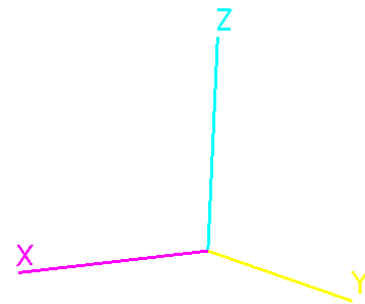

View – Scale Bars



Any scale bars listed in the project scale bars folder will be signaled using a yellow line drawn between the two ends.

View – AutoBar

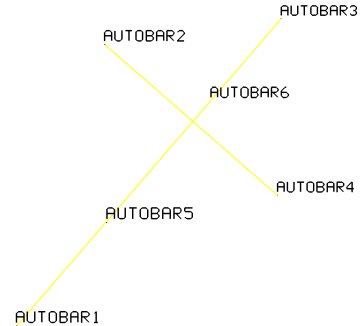
If an AutoBar is present, then yellow lines will be drawn through the ends of the AutoBar points. (AutoBar 1 – AutoBar3 and AutoBar2 – AutoBar4)



View – Labels

Switch the labels on or off for a 3D file. The labels can also be toggled using the  key. The size of the labels can be controlled using the Label Scale input box or the  or  keys.

View – Normals

The positive direction of a plane or surface may be determined by viewing the normals. Within V-STARS, the normals indicate the positive direction of the plane or surface.

Switch the normals on or off for planes and surfaces. The normals are denoted by a line perpendicular to the surface/plane in the positive direction.

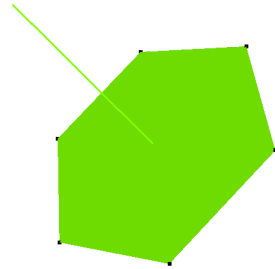



View – Normals Selected

Only view the normals when the surface or plane is selected.

View – Picture Stations

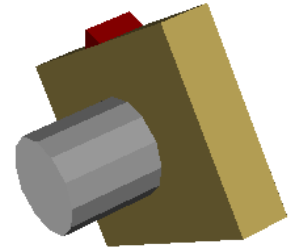
Switch the picture stations on or off. This option is only applicable to the current driver file. This command can also be implemented using the  key.



 Double-click on a camera station to view the picture taken from that station.

View – Rays

All of the points seen from a picture station and all of the picture stations that see a point can be visualized by viewing the picture and point rays. The 3D file must be the active driver in order for this feature to be active. Select a picture station to see all of the points that are seen by that particular picture station. A green line is drawn from the picture station to each point seen. A red line means that the point is rejected at that particular station. Select a point to see all of the picture stations that see that particular point. A green or red line is drawn from the point to the picture station depending upon whether or not the point was rejected. Selecting a camera displays all the points seen from that particular station. Double clicking the camera will open the image captured from the station.

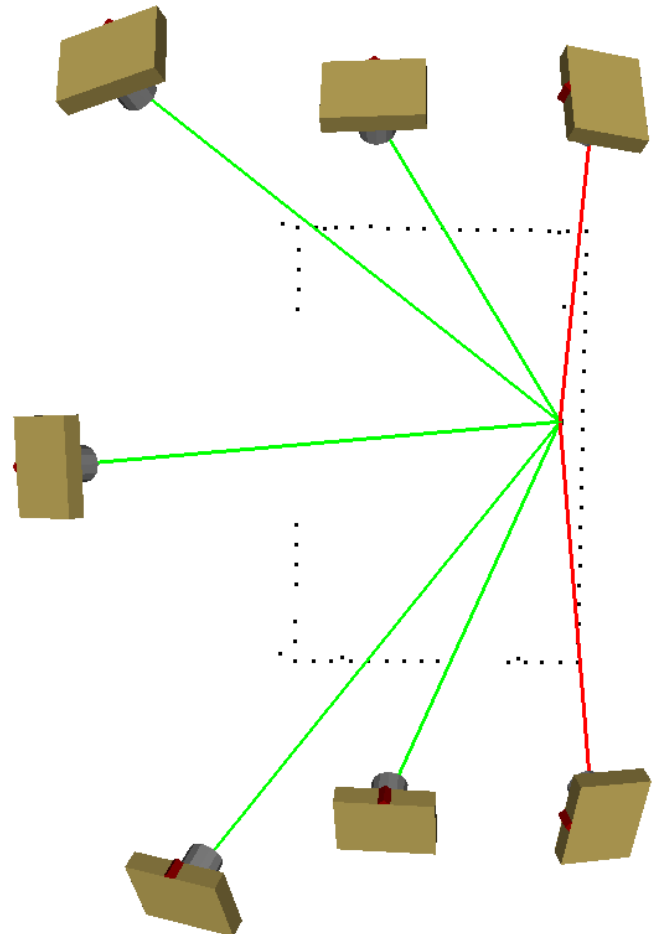

This command can also be implemented using the  key.

 The picture stations must be switched on before the rays will be active.

 The rays are only available in the active bundle.

View – Wireframe

Switch off the solid modeling of surfaced and planes.

This command can also be implemented using the

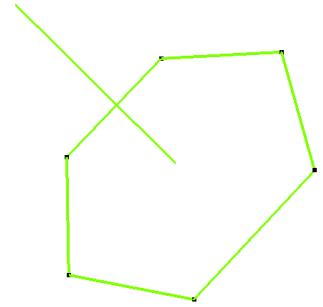

View Lighting

When lighting is switched on, surfaces, planes and cameras are shaded based on a light source being present at the viewpoint in the 3D file. This gives the object a more realistic 3D feel. This command can also be implemented using the



Tolerance Bar

When the tolerance bar is switched on, it will be displayed on the right hand side of the screen. To change the tolerance bar, check the tolerance tab of the View Setup. This command can also be

implemented using the  key.

Enable Tool Tip

When the tool tip is switched on, it will be displayed information about the object the mouse is over in a tool tip box.

Measured Point
Label: TARGET86
X: 992.029
Y: -38.627
Z: -12.559

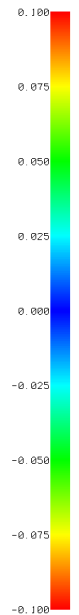



Axis Size

This input box controls the size of the Axis.



Step Scale

The Step size is used to control how much the keyboard commands increment and decrement certain settings. The residual, measurement and label scale commands are affected by this value.

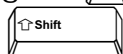

Point Size

This input box controls the size of the point entities. The size of the points can also be controlled using the  or  keys to decrease and increase the size respectively. Hold the  key to augment the step.

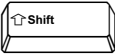

Line Width

This input box controls the width of the line entities. The width of the lines can also be controlled using the  or  keys to decrease and increase the width respectively. Hold the  key to augment the step.



Label Scale

This input box controls the size of the labels. The size of the labels can also be controlled using the  or  keys to decrease and increase the size respectively. The  key can be used to switch on the labels.

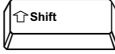
Residual Scale

In cases where the vectors are very small, it is desirable to add a scaling factor. The size of the vectors can also be controlled using the  or  keys to decrease and increase the vector scale. Hold the  key to augment the step.

Measurement Scale

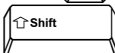
This input box controls the size at which measurements to entities are displayed. The size of the vectors can also be controlled using the  or  keys to decrease and increase the vector scale. Hold the  key to augment the step.



Translation Multiplier

The Translation Multipliers control the sensitivity of the viewpoint manipulations. A value of 1.0 indicates normal sensitivity, a value of 2.0 will double the sensitivity and a value of 0.5 will halve the sensitivity.

Rotation Multiplier

The Rotation Multipliers control the sensitivity of the viewpoint manipulations. A value of 1.0 indicates normal sensitivity, a value of 2.0 will double the sensitivity and a value of 0.5 will halve the sensitivity.

Label Skip

The label skip determines how many points to skip when displaying the labels. If the skip is set to one then all labels are displayed, if the skip is set to two then every second label is displayed. Press the  and  keys to decrease and increase the label skip.

Tolerances

The color of the difference vectors may be setup by selecting the Tolerance tab of the **View Setup Dialog**. A color Tolerance Bar shows what range value is associated with what color is available. On the second page of the View Setup dialog, under the **General (cont.)** is the Tolerance Bar check box. This check box will turn the Tolerance Bar on and off. The Tolerance Bar may also be toggled on and off by pressing the  key.

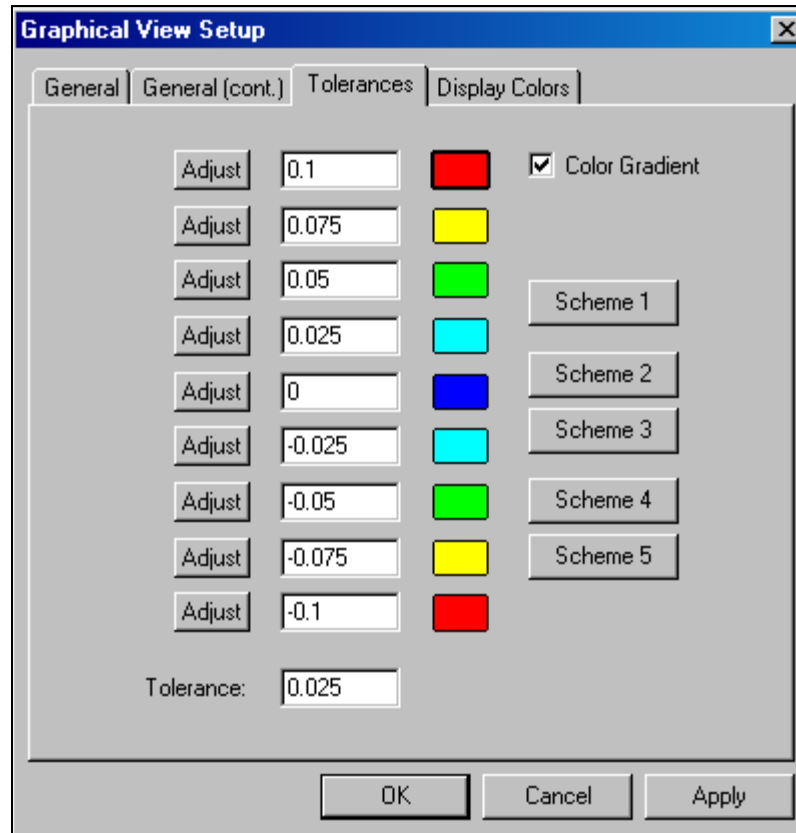

Adjusting the Tolerance

The center column of edit fields contains the numerical ranges that correspond to the colors to the right. You may edit these values directly (keeping in mind that the upper value must be larger than the lower value) or you can use the **Adjust** buttons.

The **Adjust** buttons allow you to automatically set all of the ranges based on a standard tolerance value. To use the **Adjust** buttons first enter a tolerance value in the tolerance field at the bottom of the page. Next, select one of the edit fields above and enter a value. If you wish the tolerance bar to have a middle value of zero, then simply press the **Adjust** button in the middle of the range. All other tolerance values are adjusted from this field using the tolerance range in the input box.

Setting the color

On the right side of the page is a column of color buttons. To change color, click the color button and you will be presented with the standard Windows color dialog. Select the color you want and click **OK**.

Color Gradient

Check the gradient check to create a smooth gradient between adjacent colors.

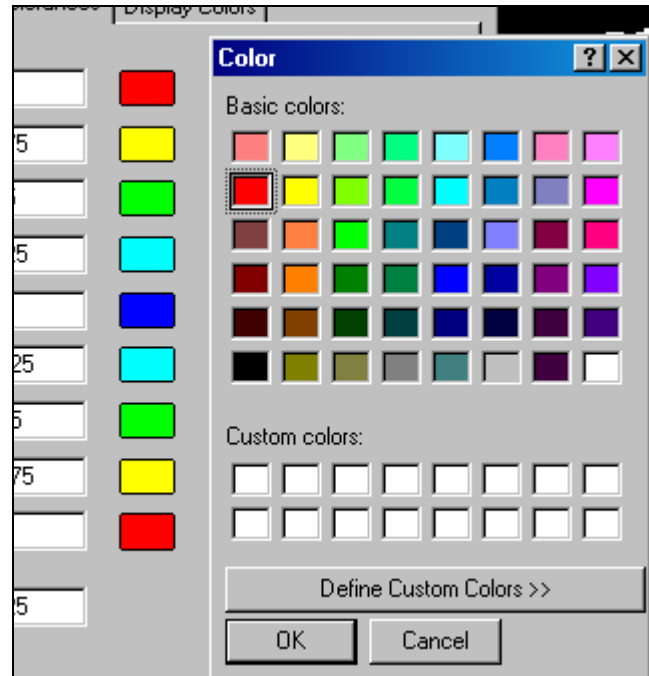
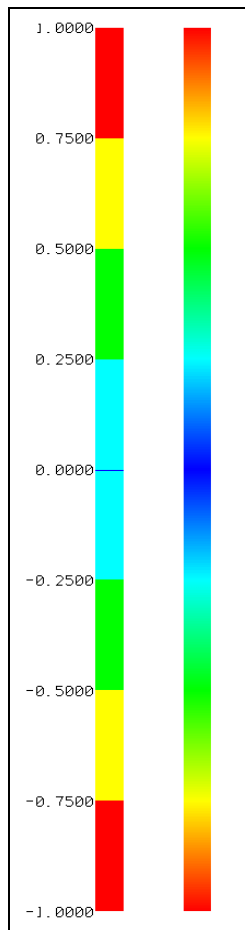

Color Schemes

There are five standard color schemes available. These are shown below.

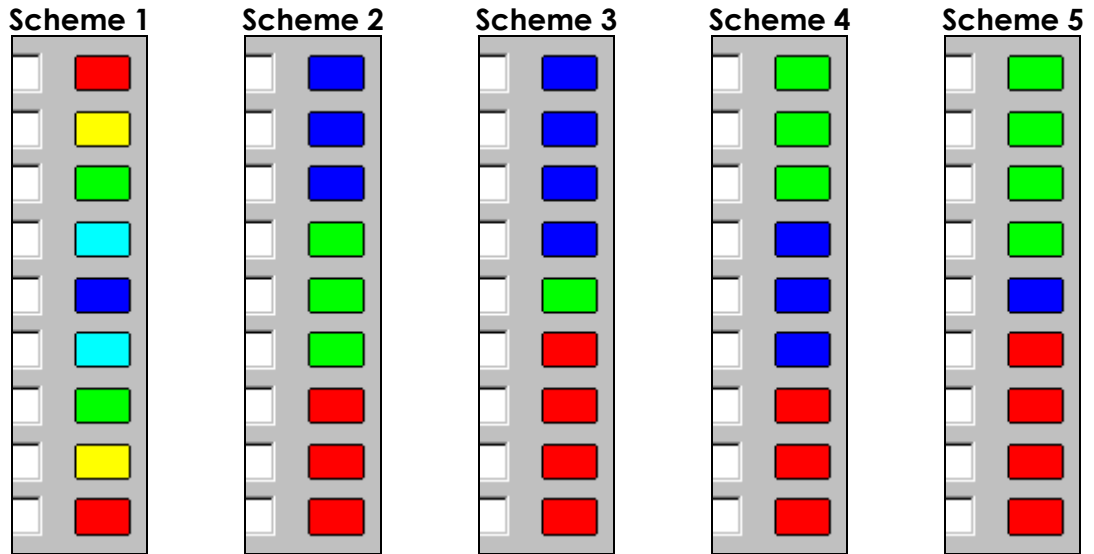

Display Colors

The colors of the various entities can be set in the Display Colors dialog. To change color click the color button and you will be presented with the standard Windows color dialog. Select the color you want and click **OK**.

Invert Print

Check the box to invert points and the background for a screen print. This is a handy way to save printer toner!

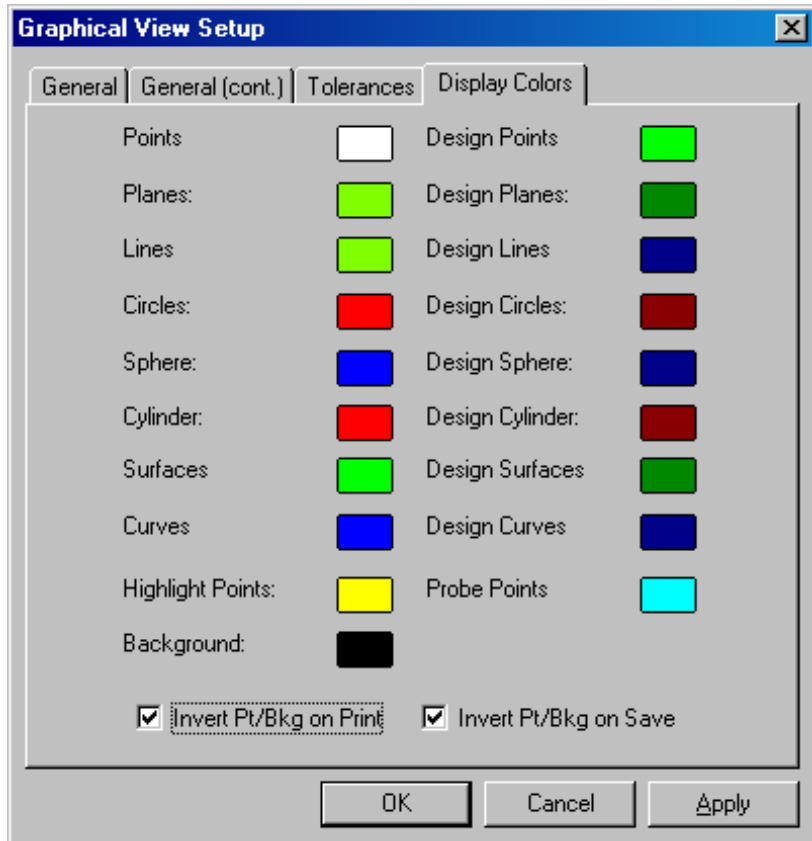



Invert Save

Check the box to invert points and the background for a screen save.

Additional Display Options

Title and Window Dimensions

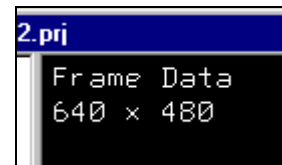

Press the  key to toggle the name of the 3D file on and off. Press the  key to toggle the window dimensions on and off.



Perspective and Orthographic



There are two main view settings: Perspective and Orthographic. The default is Perspective because this is how the real world is perceived. The further the objects are from the viewpoint the smaller they appear. Orthographic view is a mode in which all objects appear to be the same size regardless of their distance from the viewpoint. Perspective and Orthographic views may be toggled using the  key .

Center of Rotation

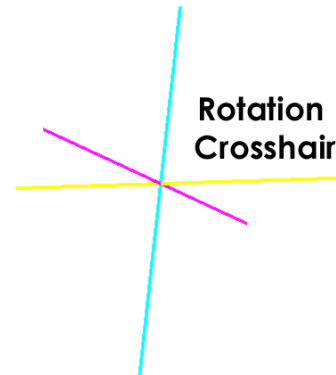
The center of rotation is displayed with a cross hair. By default, the cross hair is hidden. Press the  key to show the cross hair. This will increase the divisor value to one. The size of the cross hair is equal to the size of the coordinate axis divided by the cross hair divisor. To increase the cross hair division, thus decreasing the cross hair size press the  key. To decrement the cross hair divisor, thus increasing the cross hair size, press the  key. When the cross hair divisor is equal to zero the cross hair is hidden.



Field of View

The field of view is controlled using the  and  keys. The field of view is only used while in the Perspective view and can range from 0° to 180°.

Clipping Planes

The clipping planes control how much of the scene is displayed. Usually the 3D viewer takes care of the clipping planes and you should never have to modify them. There are two clipping planes used, the near plane and the far plane.

Near clipping plane, Inc / Dec



Far clipping plane, Inc / Dec



Alignments

Introduction

Alignments are normally used to transform from the local V-STARS coordinate system into your desired coordinate system. If the AutoBar is used, the V-STARS measurement is in the coordinate system defined by the AutoBar. If an AutoBar is not used, the measurement is in the coordinate system defined by whatever driver is used at the start of the measurement. In either case, this is not usually the final coordinate system desired. Often, the coordinate system is defined by a subset of the measured points that have coordinates in your desired coordinate system. These points may consist of precisely made tooling targets that are located in bushed holes, or they may be defined by features on the measured object (such as part edges, or hole locations or intersections of lines, planes, etc.) that are targeted in some way. In any case, it is important that the points representing your defined coordinate system be targeted precisely or else the accuracy of the transformation will be degraded. In fact, the accuracy of placing the targets precisely on your coordinate system's defining features often is the determining factor in overall measurement accuracy.

V-STARS can perform several different types of coordinate transformations. These include:

- **Axis Alignment** - The Axis Alignment Transformation exactly aligns three specified points with the coordinate axes. Axis alignment is also often called 321 alignment or Point-Line-Plane alignment. The Axis Alignment coordinate system is defined by the location of the first point (called the Anchor point), by the line connecting the first point to the second point (called the Axis Point), and by the plane defined by the first two points and the third point (called the Plane Point).
- **Quick** - The Quick transformation uses all of the common points in the Design and Measured folders for the transformation. Quick transformation is commonly used when all the control points are considered equally accurate (for example, when some previously measured or otherwise established tooling points on a part are used to define your coordinate system). The Quick transformation gets its name from the fact that the operator normally has to do very little to run the transformation. Since the accuracies for all the points are identical, there is no need to setup the accuracy estimates in the Design file; the Quick transformation will do it for you.

The Quick transformation can also be useful when trying to get the best possible comparison between two sets of measurements. By comparing the two sets of measurements after transformation into a

common coordinate system, the best possible agreement between the two sets is achieved.

- **Standard** – The Standard transformation is the most powerful since it provides the operator with the greatest control over the transformation, but it involves the most work to setup. Use the Standard transformation when the control points are of unequal accuracy. This is appropriate, for example, when there is alignment data that may only be accurate in one or two directions. For example, points on a base plane may define the Z value, but not the X and Y. In a Standard transformation, the Z value would be held FIXED and the X and Y allowed to remain APPROXIMATE or UNKNOWN.
- **File** – Transformations based on imported transformation parameters.
- **Manual** – Transformations based on manual shifting, rotation and scaling of the data.

The Quick and Standard transformations are so-called “rigid-body” transformations. Rigid-body transformations allow up to seven parameters in the transformation. These include three translations (in X, Y and Z), three rotations (one about each axis) and scale. Such a transformation is called rigid body because it does not allow the shape of the object to change; it only allows the object to be moved, rotated and (optionally) re-scaled into your defined coordinate system.

In general, V-STARS transforms the Measured point coordinates into the desired coordinate system using the Design data.

Design Data

Introduction

Starting with version 4.0, V-STARS introduced a new concept called design data. Design data normally represents engineering nominal values for points being measured. By proper use of design data, a measurement can be set up to automatically transform into a desired coordinate system. In addition, the differences between the measured and design data are automatically computed and can be viewed graphically.

Importing

Consider a project with two 3D files, Final Frame and Frame Points. Final Frame contains newly bundled measurements and Frame Points are engineering nominals of the part. We desire to compare Final Frame to Frame Points. Therefore, we wish to have Frame Points as design data within Final Frame. We do this by importing Frame Points into Final Frame as design data.

This is done by right clicking on the Final Frame 3D file and selecting **Import**. Then, select **To Design**. When the file open dialog is displayed, Frame Points is selected. A summary of the number of points imported will be displayed.

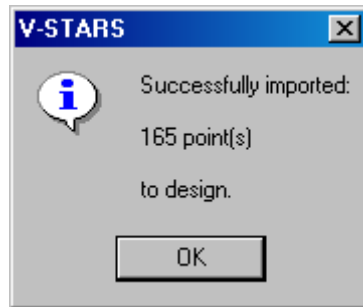
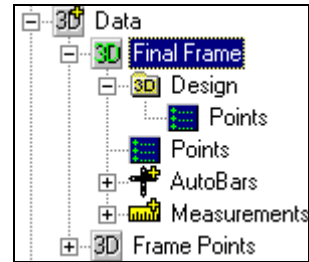
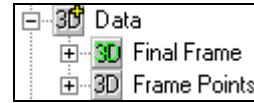

The data from Frame Points is now in the design folder of Final Frame.

The XYZ values of the design points can be viewed by clicking on the design points as shown below.

Point Label	X	Y	Z	Sigma X	Sigma Y	Sigma Z	Offset
1001	0.000	0.000	0.000	FIXED	FIXED	FIXED	0.000
1002	53.206	0.865	-0.313	FIXED	FIXED	FIXED	0.000
1003	101.471	1.007	-0.303	FIXED	FIXED	FIXED	0.000
1004	154.099	0.405	-0.316	FIXED	FIXED	FIXED	0.000
1005	203.360	0.574	-0.304	FIXED	FIXED	FIXED	0.000
1006	256.103	0.463	-0.302	FIXED	FIXED	FIXED	0.000
1007	305.809	0.393	-0.296	FIXED	FIXED	FIXED	0.000
1008	356.789	0.865	-0.327	FIXED	FIXED	FIXED	0.000
1009	408.328	0.936	-0.309	FIXED	FIXED	FIXED	0.000
1010	459.342	1.692	-0.307	FIXED	FIXED	FIXED	0.000
1011	509.156	0.895	-0.295	FIXED	FIXED	FIXED	0.000
1012	560.821	0.316	-0.270	FIXED	FIXED	FIXED	0.000
1013	611.524	0.446	-0.248	FIXED	FIXED	FIXED	0.000
1014	661.561	0.953	-0.257	FIXED	FIXED	FIXED	0.000
1015	711.838	1.027	-0.213	FIXED	FIXED	FIXED	0.000
1016	763.557	0.894	-0.195	FIXED	FIXED	FIXED	0.000
1017	813.917	1.253	-0.191	FIXED	FIXED	FIXED	0.000
1018	866.385	0.684	-0.164	FIXED	FIXED	FIXED	0.000
1019	915.115	0.993	-0.110	FIXED	FIXED	FIXED	0.000
1020	966.582	0.201	-0.099	FIXED	FIXED	FIXED	0.000
1021	1017.551	0.994	-0.108	FIXED	FIXED	FIXED	0.000
1022	1063.332	1.275	-0.090	FIXED	FIXED	FIXED	0.000

Comparing Measured to Design

Once design data is imported into a 3D file, the two data sets can be easily compared. V-STARS compares two data sets by aligning them to the same coordinate system. A comparison is automatically done by virtue of an alignment. To compare the two data sets, begin by right clicking on the Bundle you wish to transform and select **Quick** from the **Alignment** menu.

The Alignment - **Quick** dialog will appear. Press **Begin** to start the alignment calculation. After the calculation is made, summary information is shown. Refer to the [Alignment](#) option section for more information.

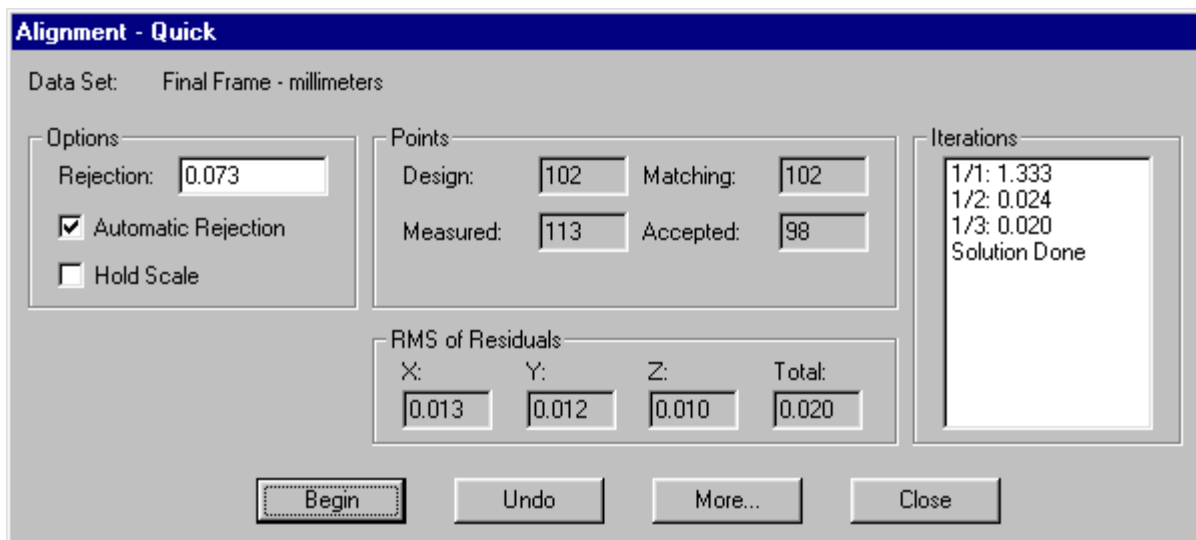
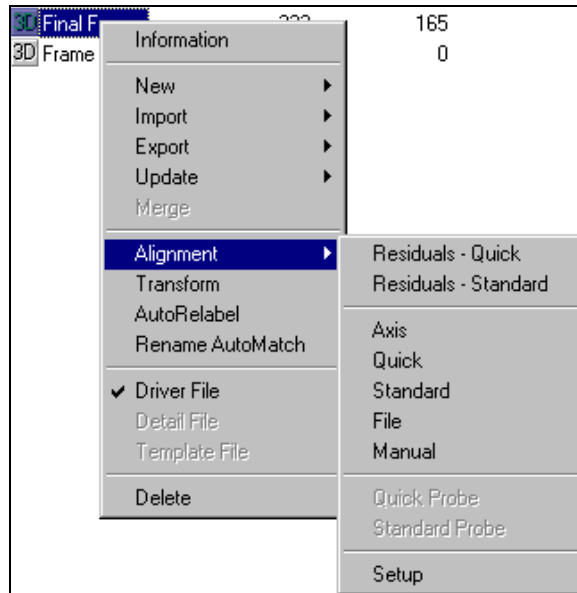

To see full details of the point-to-point differences between measured and design, press the **More** button. The **More** button brings up the Alignment Information dialog. This dialog shows individual point deviations. Rejected points are placed at the top of the list.

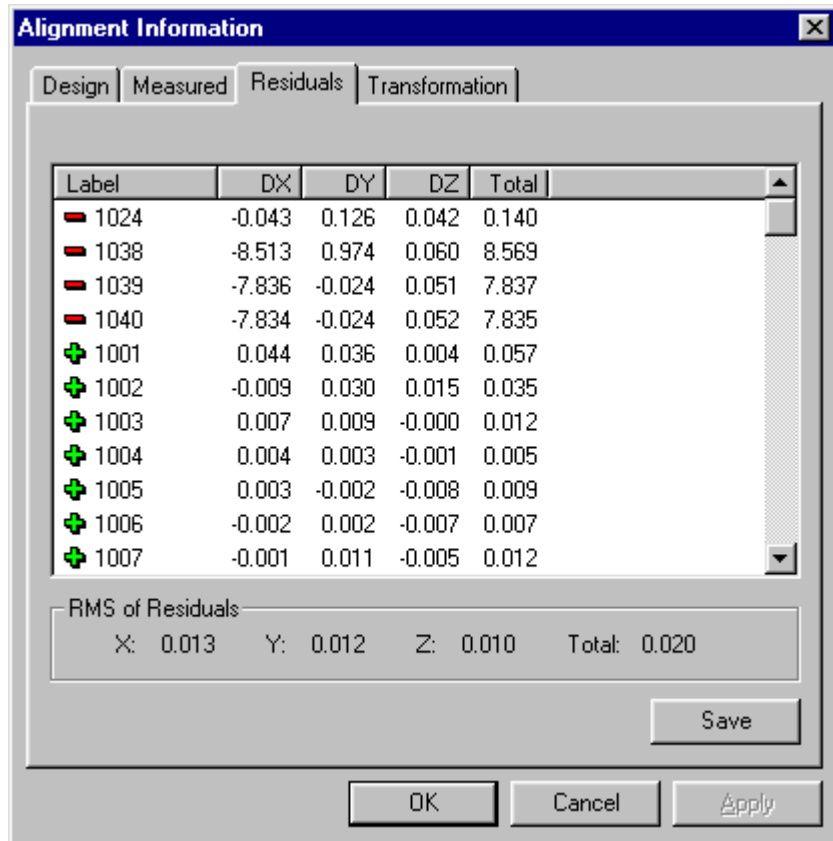

Press the **Save** button to save the results of the alignment to a text file.

Viewing the Differences Graphically

In addition to calculating differences (measured to design), V-STARS also allows those differences to be viewed graphically. To do this, select the appropriate 3D file. Then, activate the 3D viewer by clicking in the view.

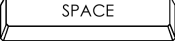
Press the  to Fit the points to the display.

Since measured to design residuals are usually small, we must use a magnification factor to make the difference vectors visible. To set the magnification factor, right click in the view and select **View Setup**. Verify that the Design Residuals check box of the Vectors group is checked and the Total check box of the Components group is checked.

On the second page change the Residual Scale to a value of say 1000 and press the **Apply** button. Move the View Setup Dialog so that you can see the 3D graphic. If the vectors are too large or still too small, change the Residual scale value again. Reduce or increase the value until you are satisfied with the vector display and then press **OK**. After changing the residual scale, the difference vectors should be easily visible. A typical example is shown below.

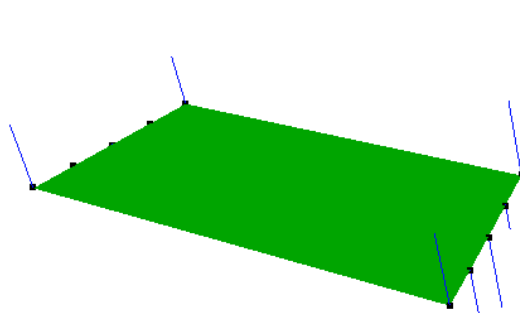
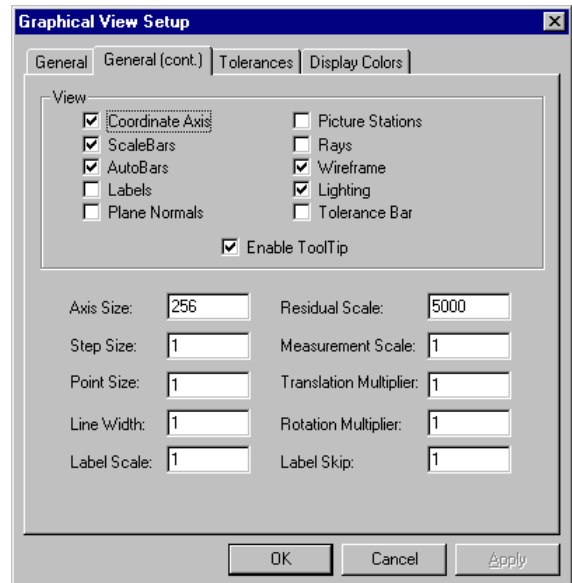
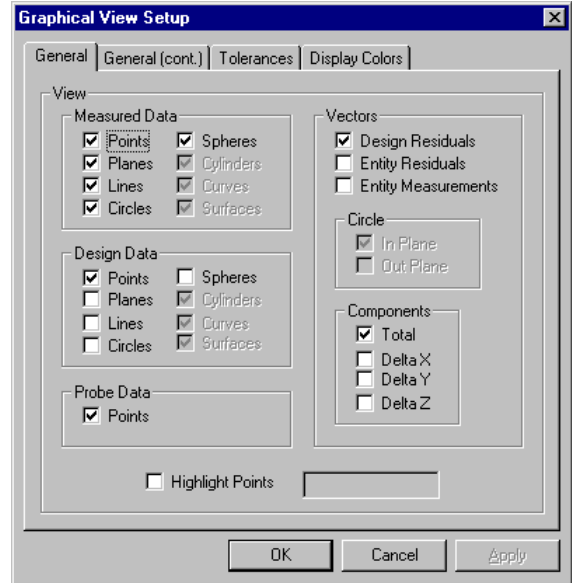

Residual Scale = 100

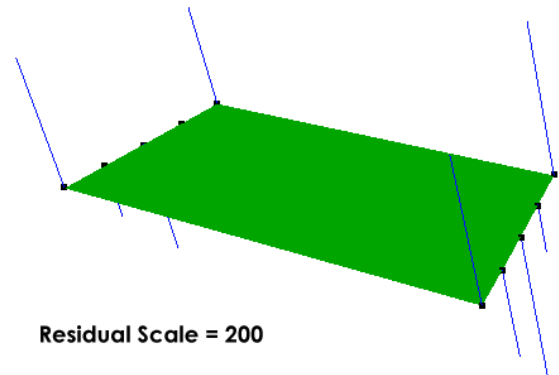

Residual Scale = 200

Creating Design Data

Design data cannot be edited directly. Design data is intentionally read-only. One way to create (and edit) a set of data to use as design coordinates is to first create a new 3D file. Do this by right clicking the 3D data folder and select **Data File** from the **New** menu option.

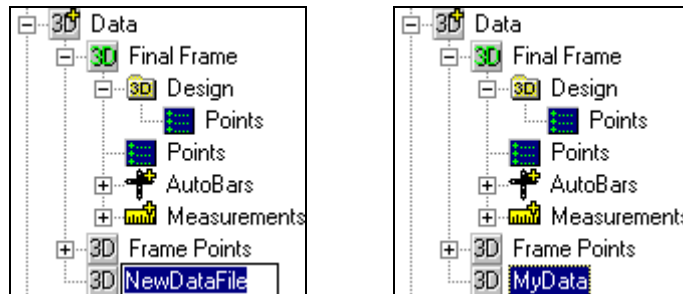

A new 3D file will be created. The new file has the default name NewDataFile and is ready to be renamed. In this example, the file was renamed to MyData.



To start adding new points, right click on MyData and select **New**. Then, select **Point**. The screen changes to a list with a single new point added.

Point Label	X	Y	Z	Sigma X	Sigma Y	Sigma Z	Offset
+ NEWPOINT	0.000	0.000	0.000	FIXED	FIXED	FIXED	0.000

Additional new points can be added by pressing the  key.

Each field can be edited by double-clicking the cell. Double click a label cell, for instance, to edit the label. You can use the  key and   to navigate between cells. Once you prepare the data inside the list editor, that data can be imported to design data of a different data file.

Point Label	X	Y	Z	Sigma X	Sigma Y	Sigma Z	Offset
+ NEWPOINT	1.000	1.000	2.000	FIXED	FIXED	FIXED	0.000
+ NEWPOINT1	1.500	1.500	2.75	FIXED	FIXED	FIXED	0.000

Importing Data from a File

Data can also be imported from external files. V-STARS can read any ASCII file of coordinates that has the following format (in addition to V-STARS' native "3D" format, and the IGES format).

Label X Y Z SX* SY* SZ*

* - Optional fields.

Where:

1. One or more spaces or tabs separate each field.
2. Label contains any alphanumeric combination of characters (16 chars max) not containing spaces.
3. X, Y, and Z are decimal numbers separated by spaces or tabs.
4. [Optional] SX, SY, and SZ are decimal numbers separated by spaces or tabs.

The above format is commonly called the "XYZ" format.

To import a file, right-click on the 3D data folder and select **Import**. Then, select **Data File**. Navigate to the desired file, select it and press the **Open** button. If this file is in the "XYZ" format V-STARS will prompt you for the files units. A summary of the imported points is shown and the file is added to the project.

Once an external file is imported, it can be imported to design data of a different data file. Refer to [Importing Data Files](#) Section.

Driver File with Design Points

Design points in a driver file are driven back to just like measured points. When a bundle is run and the current driver file has design points, these design points are copied to the design folder of the newly bundled file. At the end of the bundle, an automatic coordinate transformation (standard) takes place fine-tuning the alignment of the newly bundled (measured) points into the system of the design points.

Alignment Options

Residuals Quick/Standard

Selecting the **Residuals – Quick** option will display the usual residuals dialog. However, selecting the **Residuals – Standard** will display a dialog similar to the one below. The dialog has brackets around any residuals that were not included in the standard transformation (due to their sigmas not being fixed). In addition, the statistics at the bottom of the display will not include any bracketed values in their calculation.

Point Label	X	Y	Z	Sigma X	Sigma Y	Sigma Z
ERS1	298.4934	21.9827	146.2924	FIXED	FIXED	FIXED
ERS2	298.4948	-0.2246	151.4334	APPROX	FIXED	FIXED
ERS3	298.4712	-21.4437	146.4561	APPROX	APPROX	FIXED
ERS4	298.4606	-41.6743	154.9358	UNKNOWN	UNKNOWN	FIXED
ERS5	298.4563	-41.5792	176.3950	UNKNOWN	UNKNOWN	FIXED
ERS6	298.5018	-0.4182	176.8844	UNKNOWN	UNKNOWN	FIXED
ERS7	298.5383	41.5906	154.6425	UNKNOWN	UNKNOWN	FIXED
ERS8	298.5186	41.5327	176.9134	UNKNOWN	UNKNOWN	FIXED
ERS9	298.5411	41.3769	206.1472	UNKNOWN	UNKNOWN	FIXED

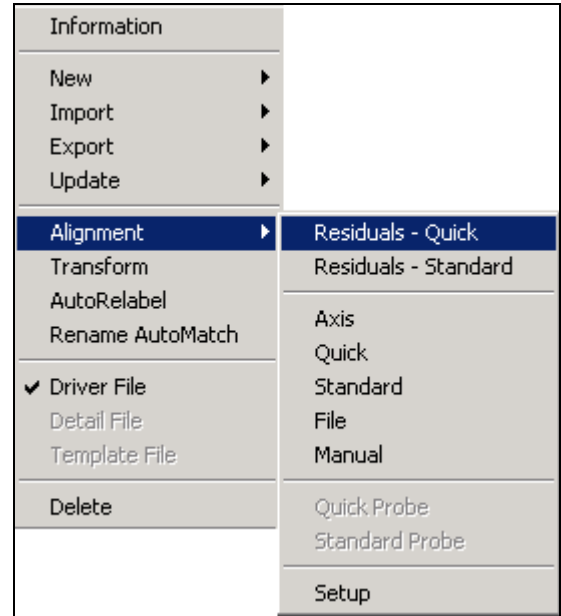

Another feature is that the transformation can be re-computed by typing in a new rejection value and pressing the **Apply** button. The results of the transformation can also be saved using the **Save** button. The results are saved to a standard ASCII format in a text file.

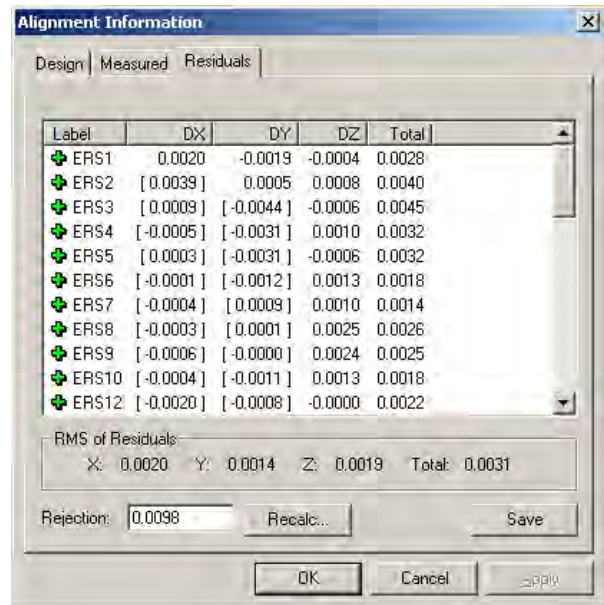

Axis

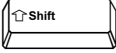
The 3D viewer portion of the axis alignment involves selecting the Anchor, Axis and Plane points in that order. Using the  key perform a single selection of the three points and select **Axis** from the **Alignment** the right click menu. The following dialog will appear.

The Anchor point, Axis point and Plane point should be set to the points you highlighted. They can be selected manually by using the pull down menus. The Anchor point can also be set by typing in the appropriate values.

The Axis direction and Plane point direction can also be set via the radio buttons. Press **Begin** to initiate the Axis alignment. Press **Undo** to reverse the alignment.

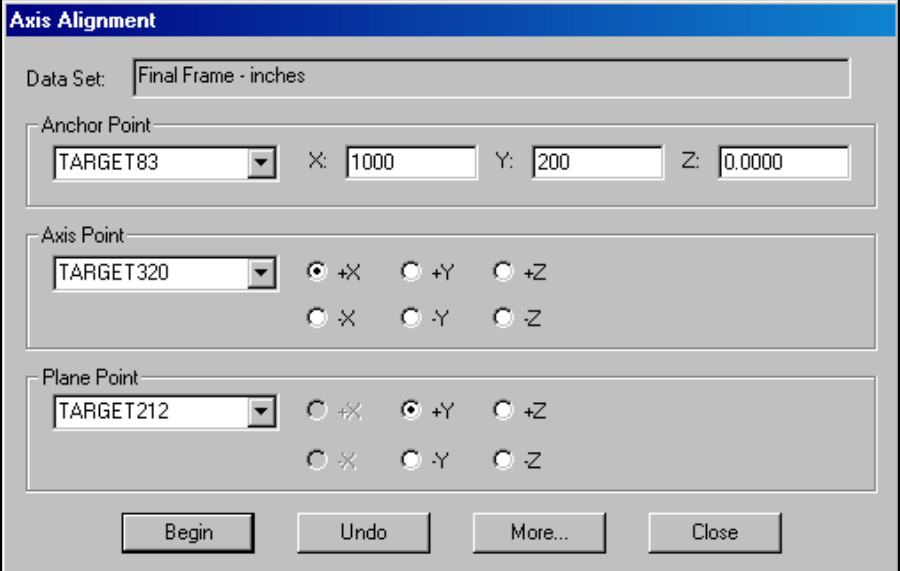

The image shows a software dialog box titled "Axis Alignment". At the top, there is a "Data Set" field containing "Final Frame - inches". Below this are three sections: "Anchor Point", "Axis Point", and "Plane Point". The "Anchor Point" section has a dropdown menu showing "TARGET83" and three input fields for X (1000), Y (200), and Z (0.0000). The "Axis Point" section has a dropdown menu showing "TARGET320" and six radio buttons for axis directions: +X (selected), +Y, +Z, -X, -Y, and -Z. The "Plane Point" section has a dropdown menu showing "TARGET212" and six radio buttons for axis directions: +X, +Y (selected), +Z, -X, -Y, and -Z. At the bottom of the dialog are four buttons: "Begin", "Undo", "More...", and "Close".

Press the **More** button to view additional information on the transformation.

Quick

Select the **Quick** option to complete a transformation in which all the points are treated equally. The dialog is shown below.

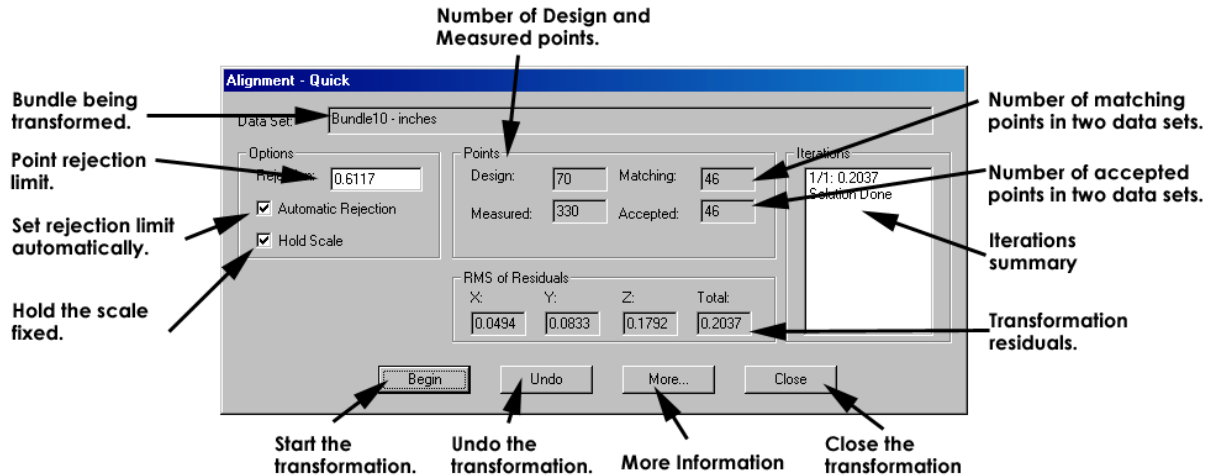

Automatic Rejection – When checked, V-STARS computes the optimal rejection limit. Uncheck this button if you wish to apply a fixed rejection limit.

Hold Scale – When checked the scale factor in the transformation is held fixed. It is common to unfix the scale when you wish the design to scale the measurements.

Points – The points frame summarizes the points involved in the in the alignment.

RMS of Residuals – The RMS frame summarizes the results of the transformation.

More – Press **More** to view additional information about the transformation.

Undo - Press **Undo** to reverse the alignment. 📄 only the last transformation can be undone.

Close – Press **Close** to accept the transformation.

Standard

The Standard transformation is very similar to the Quick transformation. The difference lies in the Design file. In a Standard transformation, the Standard Deviations of each coordinate are considered in the transformation solution. The following Standard Deviation settings are available.

FIXED	The coordinate is used in the transformation.
APPROXIMATE	The coordinate is used to help initiate the transformation, but is not used in the final transformation.
UNKNOWN	The coordinate is used in the transformation.

Changing Standard Deviation Fields

Changing an entire column – To change the entire column simply click on the Sigma X, Sigma Y or Sigma Z tab at the top of the point listing. The input dialog will appear.

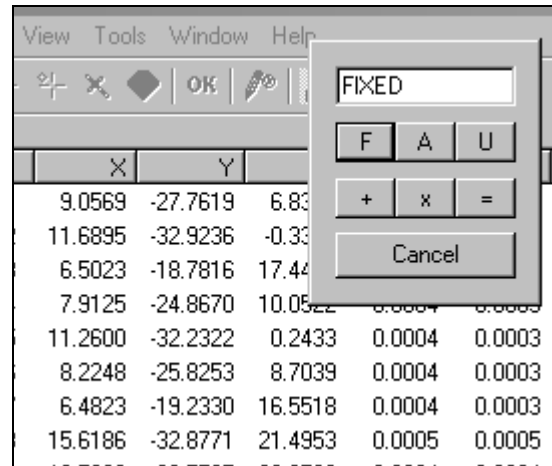

Select the appropriate

(setting and then the key to

accept the change. The entire column will change.

Z	Sigma X	Sigma Y	Sigma Z
6.8332	FIXED	0.0003	0.0003
-0.3352	FIXED	0.0003	0.0003
17.4437	FIXED	0.0003	0.0003
10.0522	FIXED	0.0003	0.0003
0.2433	FIXED	0.0003	0.0003
8.7039	FIXED	0.0003	0.0003
16.5518	FIXED	0.0003	0.0003

The addition and multiplication signs can also be used to add or multiply the values in the column. For example, if you wanted to flip the values in the Y column, you would type in and then the .

Changing selected entries – To change only a selection of entries simply select the entries you wish to change and press the Tab you wish to modify. Enter the setting and press the key.

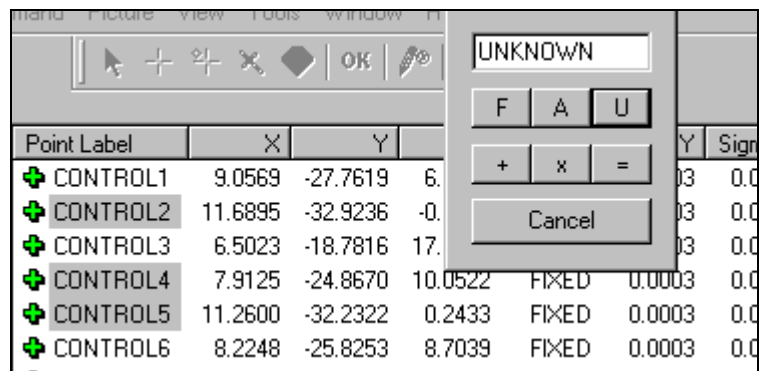

The dialog on the right shows how the Sigma X values of Control2, 4, and 5 have been changed to UNKNOWN.

Point Label	X	Y	Z	Sigma X	Sigma Y	Sigma Z
CONTROL1	9.0569	-27.7619	6.8332	FIXED	0.0003	0.0002
CONTROL2	11.6895	-32.9236	-0.3352	UNKNOWN	0.0003	0.0002
CONTROL3	6.5023	-18.7816	17.4437	FIXED	0.0003	0.0002
CONTROL4	7.9125	-24.8670	10.0522	UNKNOWN	0.0003	0.0002
CONTROL5	11.2600	-32.2322	0.2433	UNKNOWN	0.0003	0.0002
CONTROL6	8.2248	-25.8253	8.7039	FIXED	0.0003	0.0002
CONTROL7	6.4823	-19.2330	16.5518	FIXED	0.0003	0.0002
CONTROL8	15.6186	-32.8771	21.4953	FIXED	0.0005	0.0002

Changing single entries – To change a single entry, simply double click in the field you wish to enter and type in the value. Press the  to move to the next field.

0.3352	UNKNOWN	0.0003	0.0002
7.4437	FIXED	0.0003	0.0002
10.0522	UNKNOWN	0.0003	0.0002
0.2433	UNKNOWN	0.0003	0.0002

 The data in the Design is protected and cannot be changed. If changes are necessary, make the change in a 3D file and re-import the data into the Design area.

File.

The **File** alignment allows you to perform a transformation using a transformation file that is in a compatible third party package's format. Currently, transformation files from CATS, HOLOS, and GSI are supported.

Selecting the **File** option will display the following dialog. **Browse** to select the file that contains the pre-defined values. Press **OK** to implement the transformation.

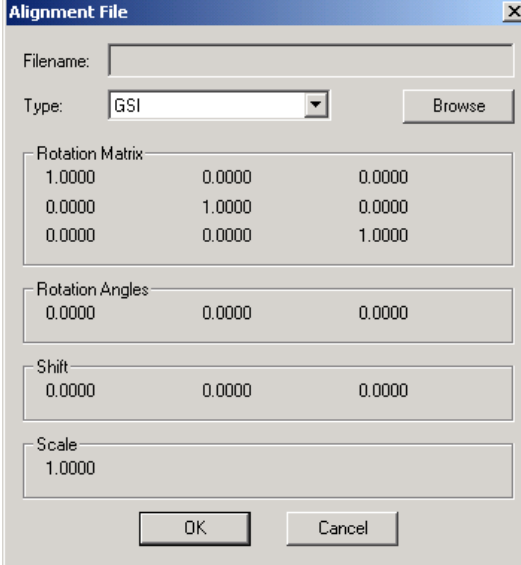

The dialog box is titled "Alignment File" and contains the following fields and sections:

- Filename: [Empty text field]
- Type: GSI (dropdown menu) with a "Browse" button to the right.
- Rotation Matrix: A 3x3 grid of text boxes containing the values:

1.0000	0.0000	0.0000
0.0000	1.0000	0.0000
0.0000	0.0000	1.0000
- Rotation Angles: A 1x3 grid of text boxes containing the values: 0.0000, 0.0000, 0.0000.
- Shift: A 1x3 grid of text boxes containing the values: 0.0000, 0.0000, 0.0000.
- Scale: A single text box containing the value: 1.0000.
- Buttons: "OK" and "Cancel" at the bottom.

Manual

The **Manual** alignment allows you to manually shift, rotate or scale a 3D file into a new position.

Select the 3D file that needs to be manually aligned and select the **Manual** option from the right-click **Alignment** menu. The following dialog will be displayed. You can shift the data in each of the three coordinate axes; you can rotate around each of the three axes, and you can change the scale.

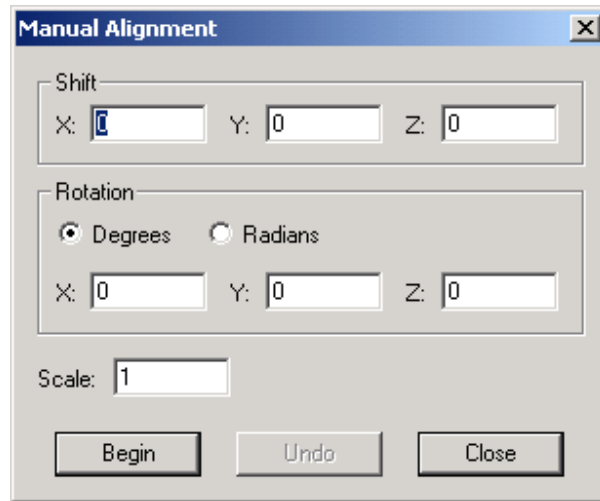

To shift the data in X, Y or Z, type the shift values in the boxes and press the **Begin** button. The value in the boxes will be added to every point in the file. To rotate the data around the X, Y, or Z-axis, enter the rotation value in the appropriate box, and press the **Begin** button. You can only rotate around one axis at a time. A positive value rotates counter-clockwise around the axis as viewed down the positive axis.

To scale the data, enter a value in the scale box and press **Begin**. Every point coordinate will be multiplied by the scale value.

 The **Undo** button will only undo the most recent alignment.

Alignment Setup

Setup – Modify the default alignment settings. By default the scale in the Quick and Standard are allowed to adjust. By default the **Automatic Rejection** is also enabled. If the Automatic Rejection is disabled, then the **Rejection Limit** can be set manually.

The **Convergence Limit** and **Maximum Iterations** can also be set.

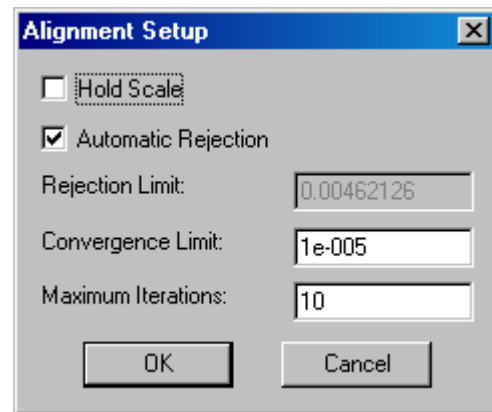

Basic Measurement Functions

Introduction



V-STARS can perform several different types of basic measurement and point creation functions. Functions that are more comprehensive are available in the optional Solids and V-SURF modules. The options can be reached by right clicking in the graphical view.

 Many of the SOLIDS objects have a **Create Template Object** check box. This check box is used to create Construction object. Refer to [Construction Objects](#) for more information.



Functions

Average

Create the average of a number of different points. Select the points and then select the **Average** command. Enter a name in the Label field and press **OK** to create the point. The **Average** command can also be reached by using the  key in the graphical view or   in the text view.

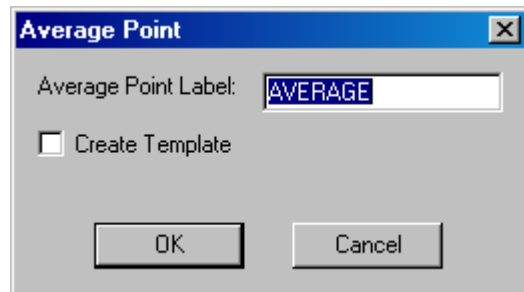

Distance

Compute the distance between two points. If two points are selected the distance will be computed immediately. If not, a point dialog appears and the two points must be selected. The Distance command can also be reached by using the  key.

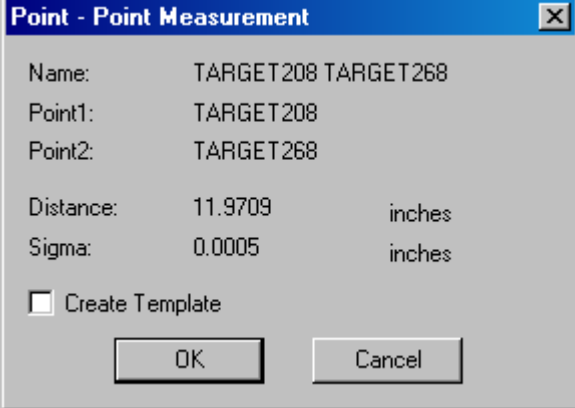

The dialog box titled "Point - Point Measurement" displays the following information:

Name:	TARGET208 TARGET268	
Point1:	TARGET208	
Point2:	TARGET268	
Distance:	11.9709	inches
Sigma:	0.0005	inches

Create Template

Buttons: OK, Cancel

Basic Measurement Functions

Vector

To create a vector point, select the two points that define the vector and select **Vector** from the right click menu or press the  key. The Vector Point dialog is displayed. Enter an offset and a new point label and press **OK** to add the point to the 3D file. To create a point in the opposite direction enter a negative number in the offset field.

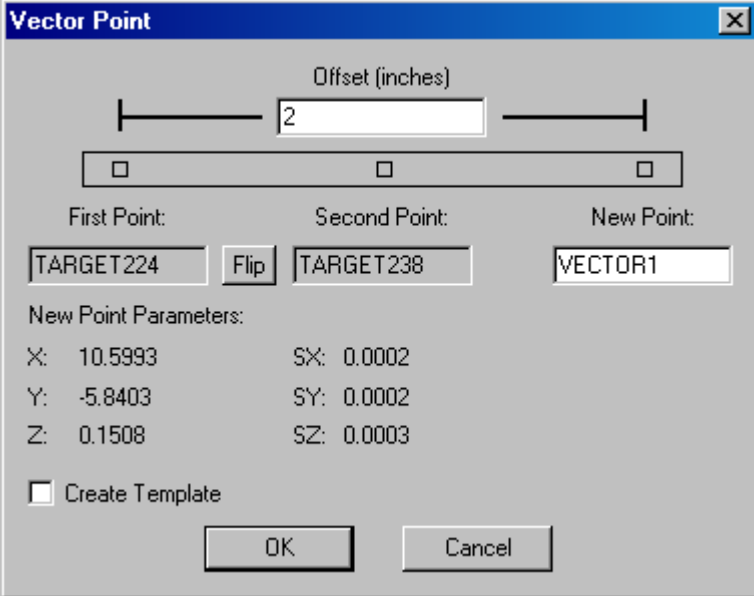

The dialog box titled "Vector Point" displays the following information:

Offset (inches):

First Point: Second Point: New Point:

New Point Parameters:

X:	10.5993	SX:	0.0002
Y:	-5.8403	SY:	0.0002
Z:	0.1508	SZ:	0.0003

Create Template

Buttons: OK, Cancel

Press the **Flip** button to flip the first and second points.

SOLIDS

SOLIDS is sold as a separate add-on to V-STARS. Please contact GSI for more information.

Introduction

SOLIDS is V-STARS' built-in graphical analysis module. Using SOLIDS, you can create Planes, Lines, Circles, Curves and Spheres by fitting point data. In addition, measurements between these entities can be calculated. For instance, Plane-to-Plane measurements can be made to determine the angle between the planes. Finally, intersecting these entities can generate new entities. For example, the line of intersection between two planes can be created. The SOLIDS menu can be reached by right clicking in the graphical window or on the 3D node or a 3D file.

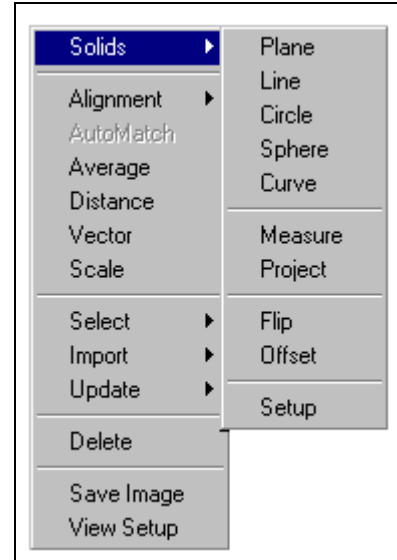

 Many of the SOLIDS objects have a **Create Template Object** check box. This check box is used to create Construction object. Refer to [Construction Objects](#) for more information.

Creating Objects

Planes

Select the data file, which contains the points to fit. Select the points that are to be included and select **Plane** from the right click menu. The Plane command can also be reached using the  key

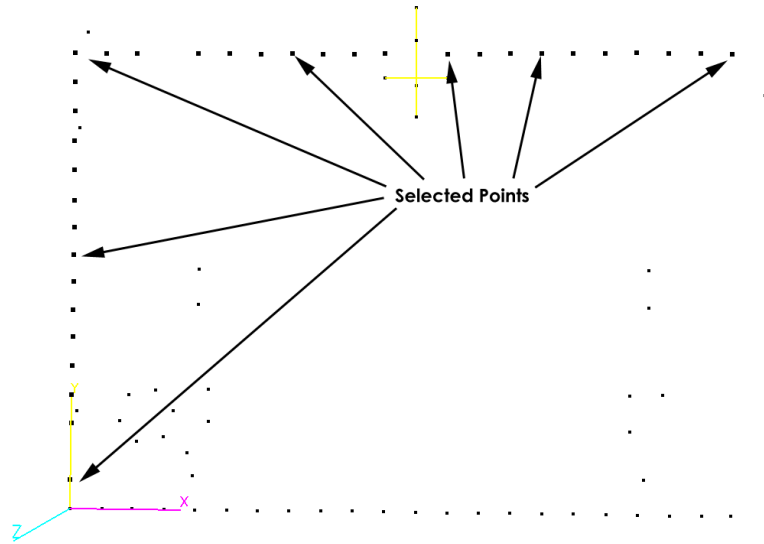

The Plane Parameters dialog appears. This dialog is used to give a name to the plane. Also shown in this dialog are the residuals and the RMS of the plane fit. If there are rejected points, they will be displayed at the top of the list.

Press **OK** to accept and add this plane to the 3D file

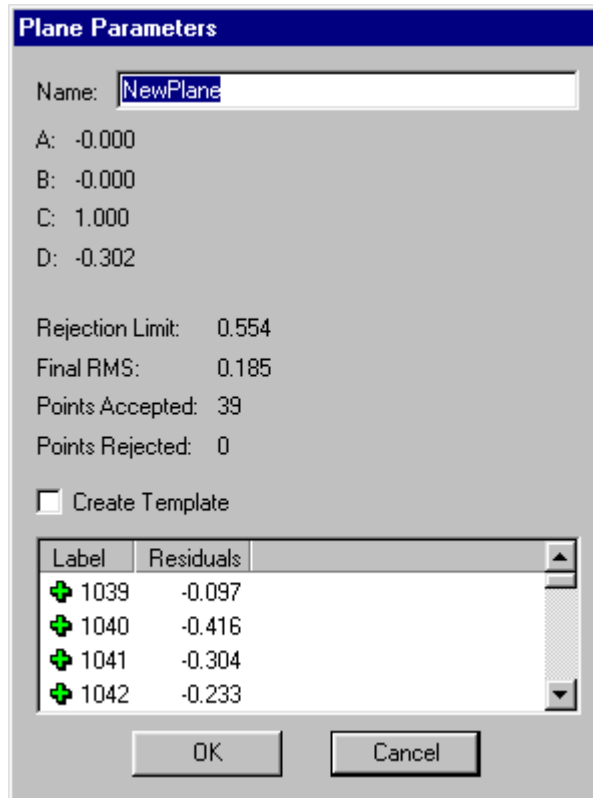

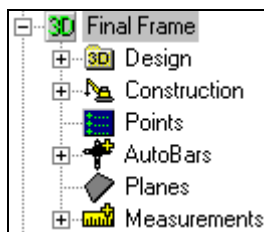
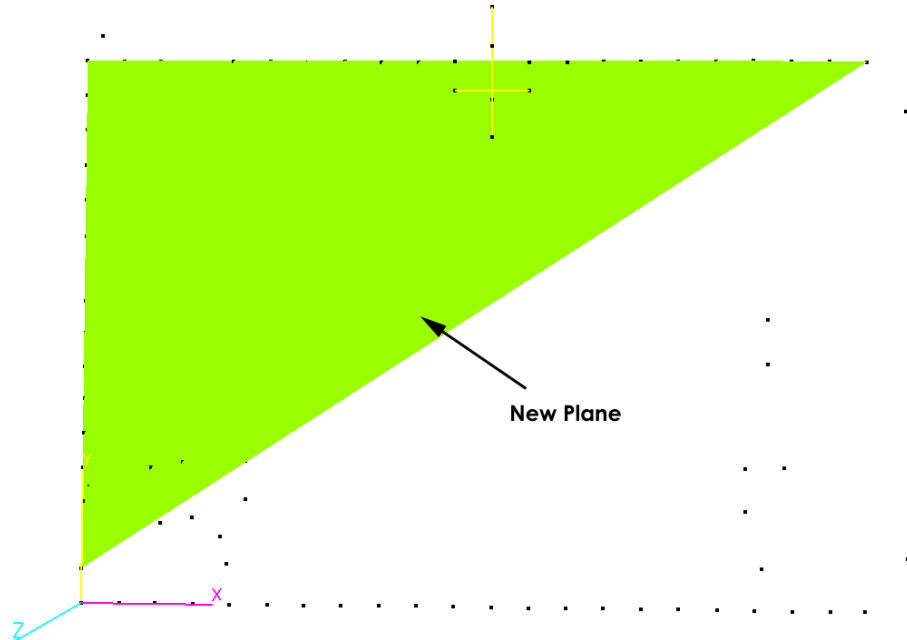



Click on the "Planes" folder in the 3D file to view the plane that has been created. A list of the planes in this 3D file is shown below.

Name	A	B	C	D	RMS
NewPlane	-0.000	-0.000	1.000	-0.302	0.185

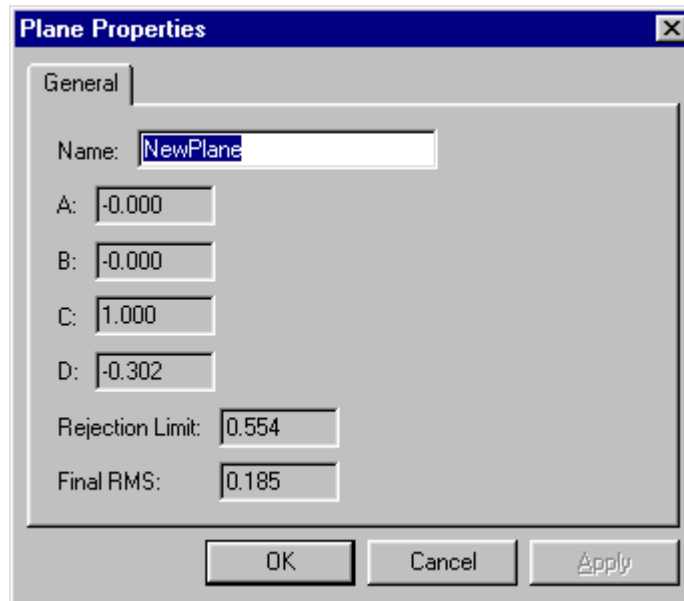
Double click on a plane in the list to display more information.



If points are obscured by the plane turn on the wireframe view of the data by pressing the  key.

Lines

To illustrate a different way of creating a SOLIDS object select the **Line** command from the right click menu without selecting any points. A list of all the points is displayed. The Line command can also be

reached using the  key.

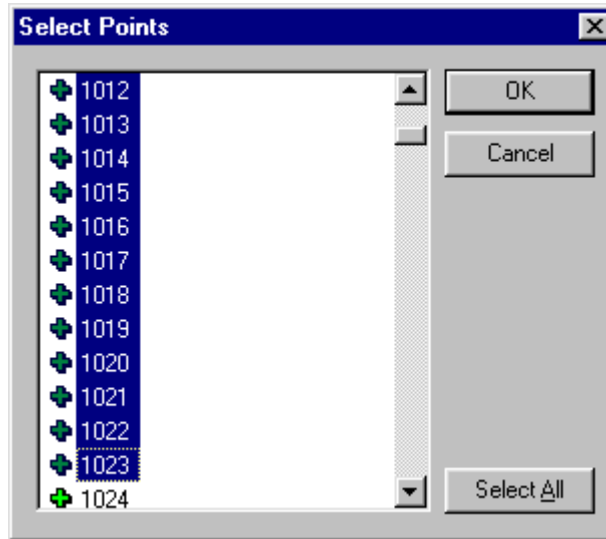

Select the desired points and press **OK**. The Line Parameters dialog appears. This dialog is used to give a name to the line. Also shown in this dialog are the residuals and the RMS of the line fit. If there are rejected points, they will be displayed at the top of the list.

Press **OK** to accept and add this line to the 3D file.

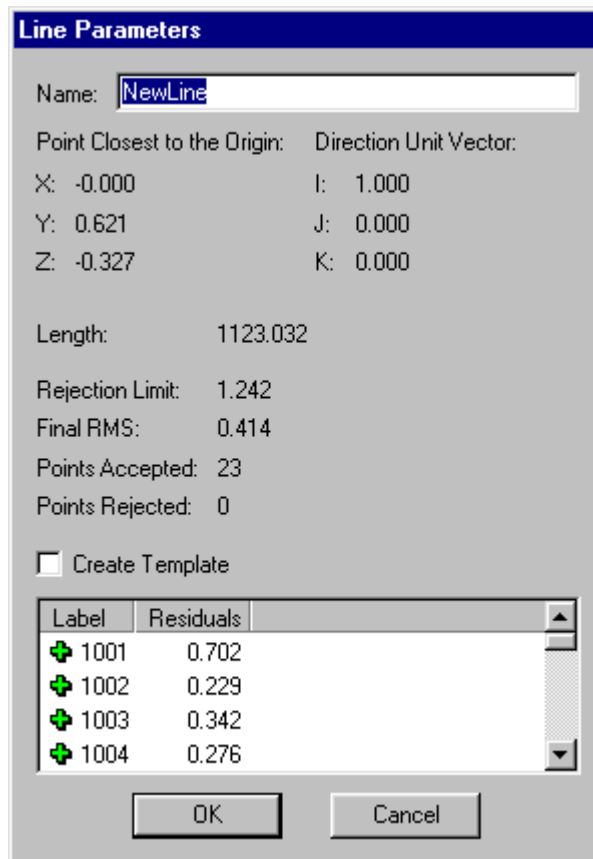
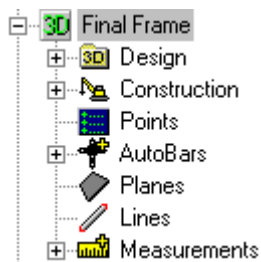

Just as with planes, the lines are now displayed on the tree.

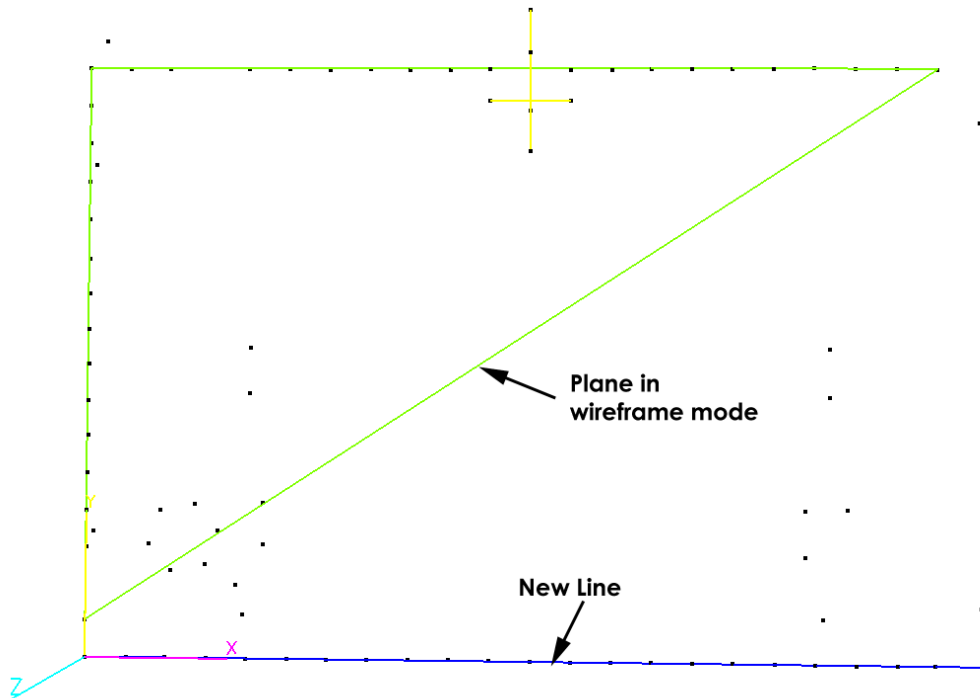



Circles

This time we will create the circle by selecting points from the points list view. Select the Points node on the tree. The list of points is displayed to the right. Select the points and select **Circle** command from the right click menu.

 The short-cut keys can be accessed while in the points view by also pressing the  key.

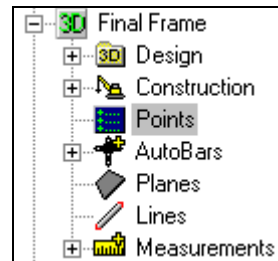

Point Label	X	Y	Z
AUTOBAR2	608.587	700.641	6.369
AUTOBAR3	557.967	637.011	6.526
AUTOBAR4	506.932	700.298	6.857
AUTOBAR5	557.620	757.643	19.553
AUTOBAR6	557.720	687.910	6.328
C1	137.542	193.312	-0.211
C2	166.379	159.643	-0.491
C3	151.566	117.817	-0.861
C4	107.876	109.607	-0.901
C5	79.453	143.289	-0.427
C6	93.964	185.233	-0.284
CIRCLE_AVERAGE	122.797	151.483	-0.529
CODE1	8.466	158.495	-0.269

The Circle Parameters dialog appears. This dialog is used to give a name to the circle. Also shown in this dialog are the in plane residuals and RMS of the circle fit. If there are rejected points, they will be displayed at the top of the list.

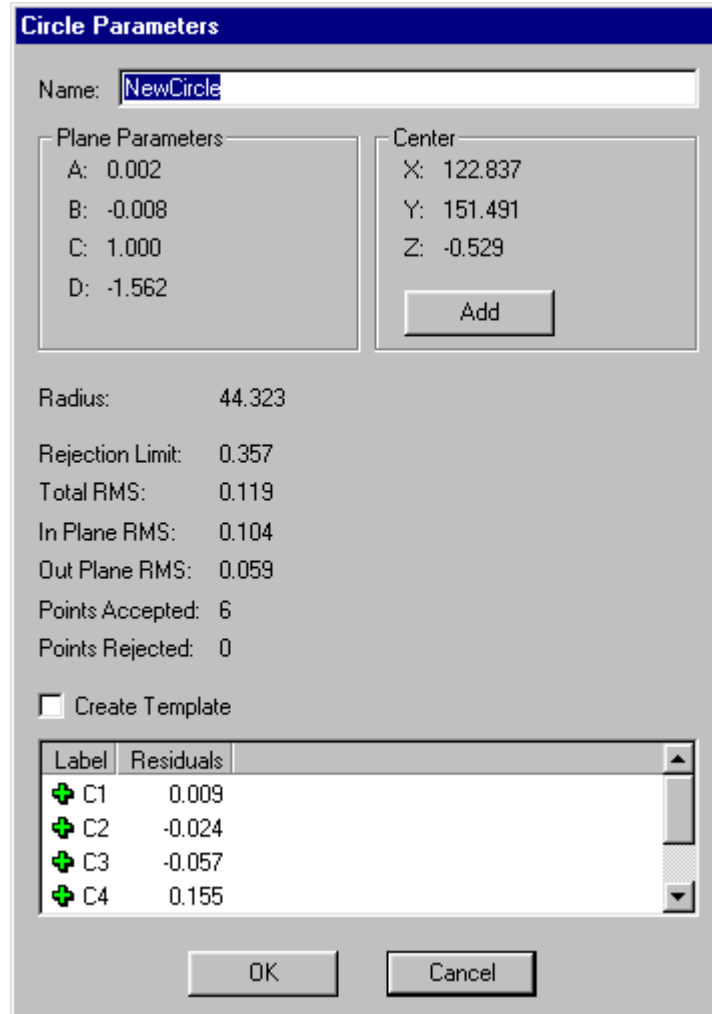

The circle residual has two components. The in plane and out plane residual. The in plane residual is the component of the circle residual that is parallel to the plane of the circle. The out plane circle residual is the component of the circle residual that is perpendicular to the plane of the circle. Below is a diagram of the in plane and out plane circle residuals.

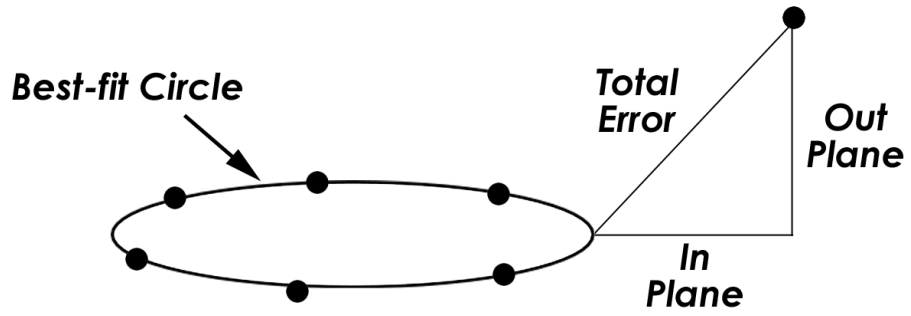

Press the **Add** button to add the center point of the circle to the 3D file.

Enter a point label in the Name field and press OK to add the point to the 3D file. Press **OK** to accept and add this circle to the 3D file

Add Point			
Name:	<input type="text" value="CIRCLE_CENTER"/>		
X:	<input type="text" value="122.837"/>	SX:	<input type="text" value="FIXED"/>
Y:	<input type="text" value="151.491"/>	SY:	<input type="text" value="FIXED"/>
Z:	<input type="text" value="-0.529"/>	SZ:	<input type="text" value="FIXED"/>
<input type="button" value="OK"/>		<input type="button" value="Cancel"/>	

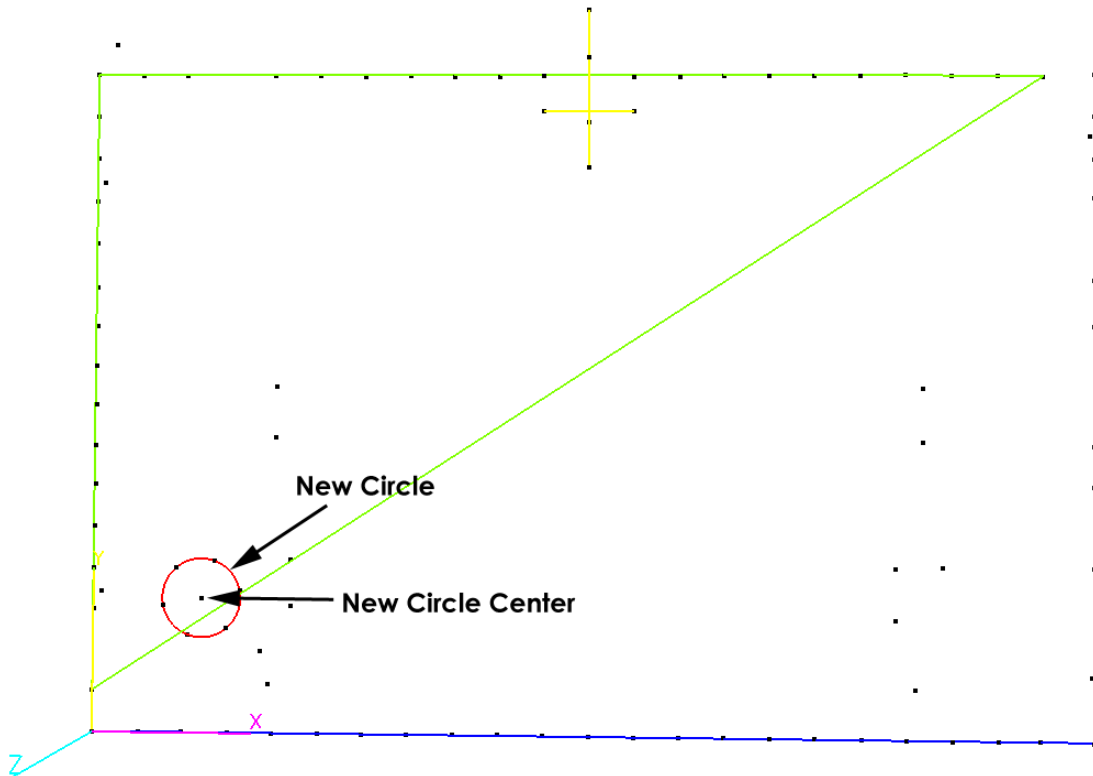

Just as with planes and lines the circles are now displayed on the tree.

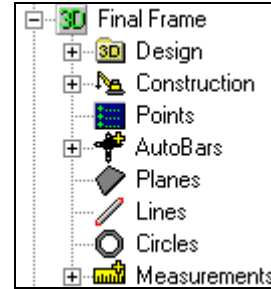

Spheres

A Sphere is created in a similar manner to that of the circle. Select the points that fall on the sphere surface, and select the Sphere command.

Curves

A Curve is created in a similar manner to that of the other geometric features described. The only important exception is that the points **MUST** be selected in the order they appear in the curve. This can be achieved by sequentially manually selecting the points or by naming the points in order.

Once the Curve command is selected, you will be presented with a dialog box. This will give you the opportunity to name the curve, reorder the points and adjust the number of control points and degree of the curve.

The control points control the shape of the curve. The number of control points must be less than or equal to the number of input points. Generally, you will not get a very good fit if the number of control points is set too high. A large number of control points will over-approximate the solution and force the best-fit curve to pass through each of the input points. The degree of the curve must be less than the number of control points.

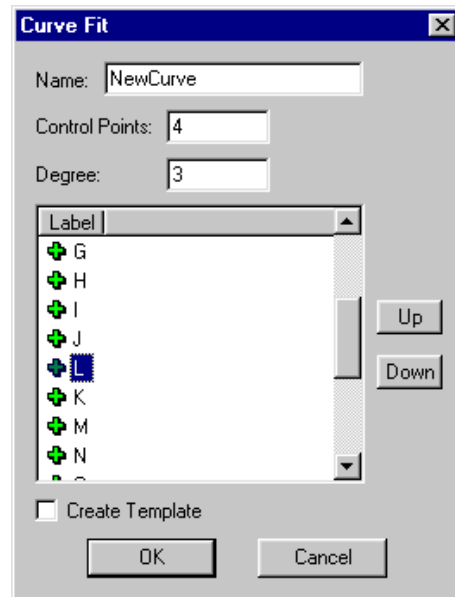

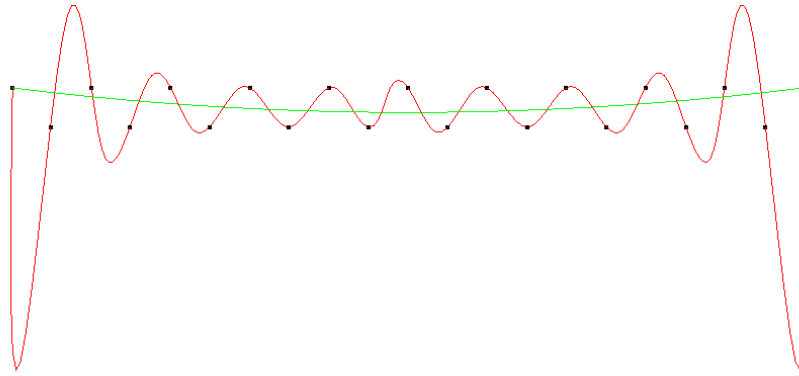

Above is an example of a curve (red curve) that was fitted with too many control points. In this example, there are 21 points. The smooth curve (green curve) was created using four control points and a degree of three. The undulating curve was created using 21 control points and a degree of three.

Measurements

Plane to Plane

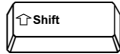
In order to perform a plane-to-plane measurement you need to select two planes. Select both planes by holding down the  key and clicking on each wireframe.

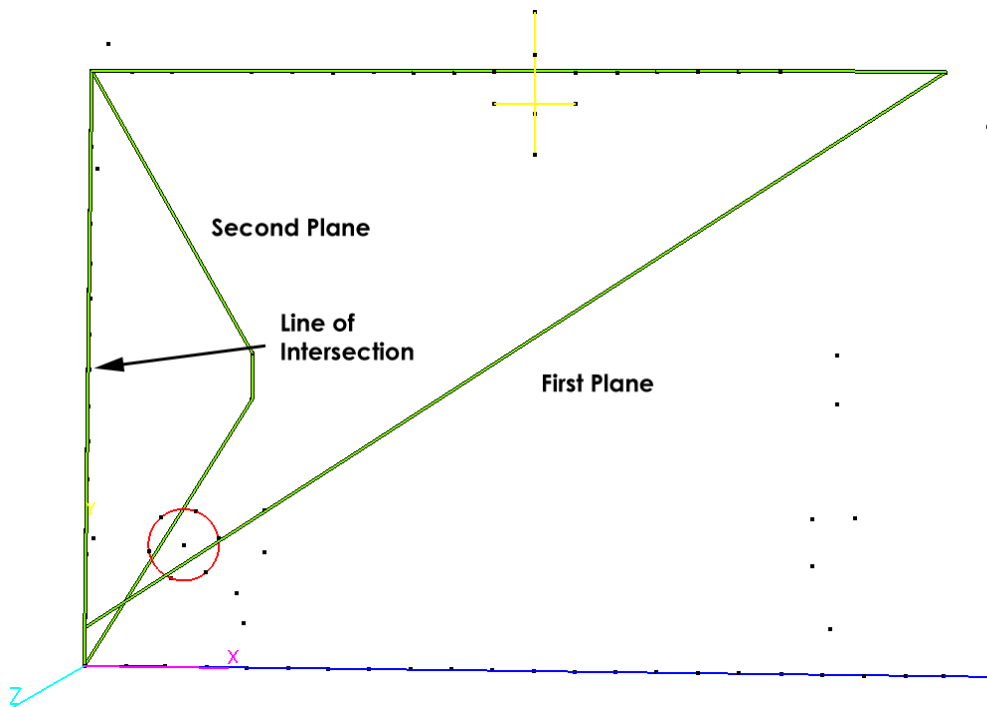

Select **Measure** from the right click **SOLIDS** menu. The **Plane-to-Plane Measurement** dialog is displayed.

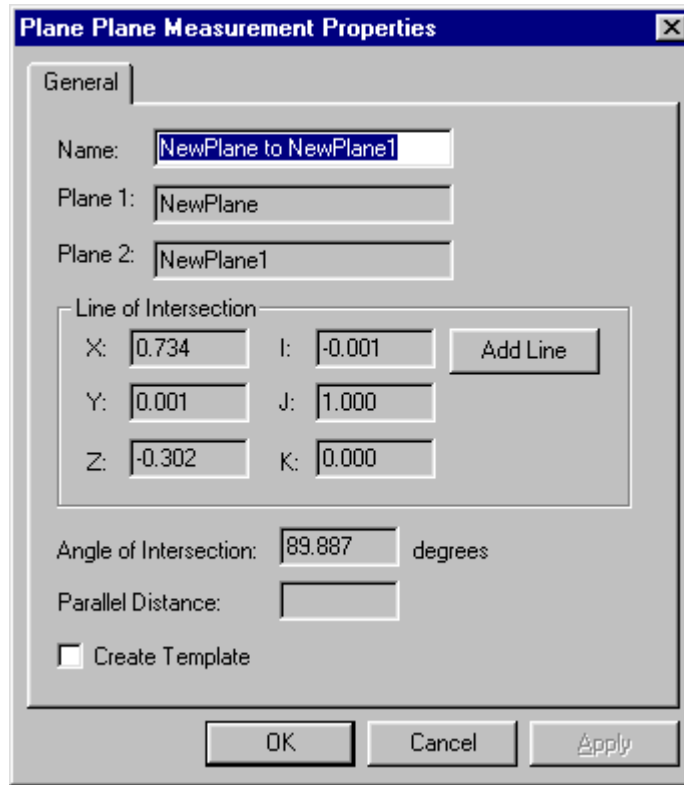

This dialog is used to name the measurement and to optionally add the line of intersection to the 3D file. If the planes were parallel, their parallel distance would be displayed. If the planes intersect, the angle of intersection is displayed and the line of intersection can be added by pressing **Add Line**.

Press **OK** to add the measurement to the 3D file. All measurements performed with SOLIDS are stored in the Measurements folder of a 3D file shown below. Select Plane to Plane under the Measurements folder to list of all the Plane-to-Plane measurements in this 3D file.

Double click on a measurement in the list to display more information.

Plane to Plane	Angle	Distance
NewPlane to NewPlane1	89.887	N/A

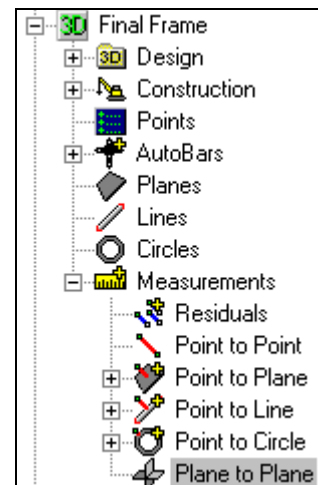

Line to Line

Two lines are needed in order to perform a line-to-line measurement.

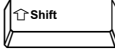
Select both lines by holding down the  key and clicking on each line.

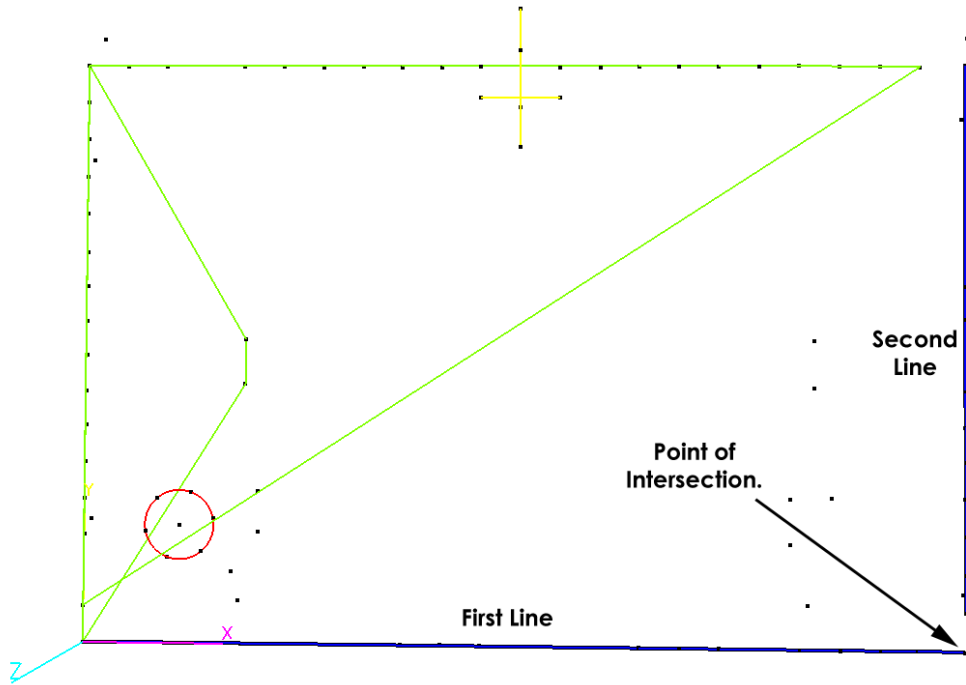

Select **Measure** from the right click **SOLIDS** menu. The Line-to-Line Measurement dialog is displayed. This dialog is used to name the measurement and to optionally add the point of closest approach between the two lines to the 3D file. The distance of closest approach is also displayed. If the two lines were parallel then this would be the parallel distance.

Press **OK** to add this measurement to the 3D file. Like the Plane to

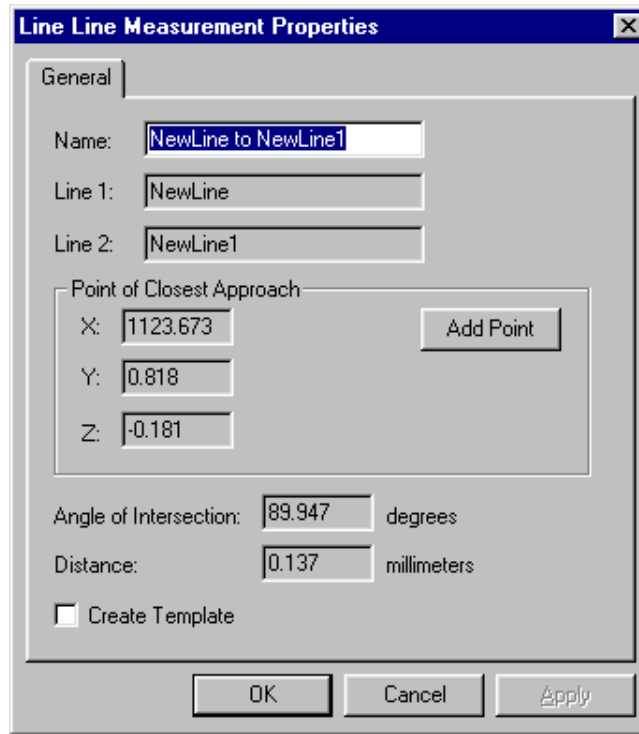

Plane measurements, Line-to-Line measurements are stored under the Measurements folder in a folder called Line to Line.

Plane to Line

To perform a plane to line measurement, select a plane and line.

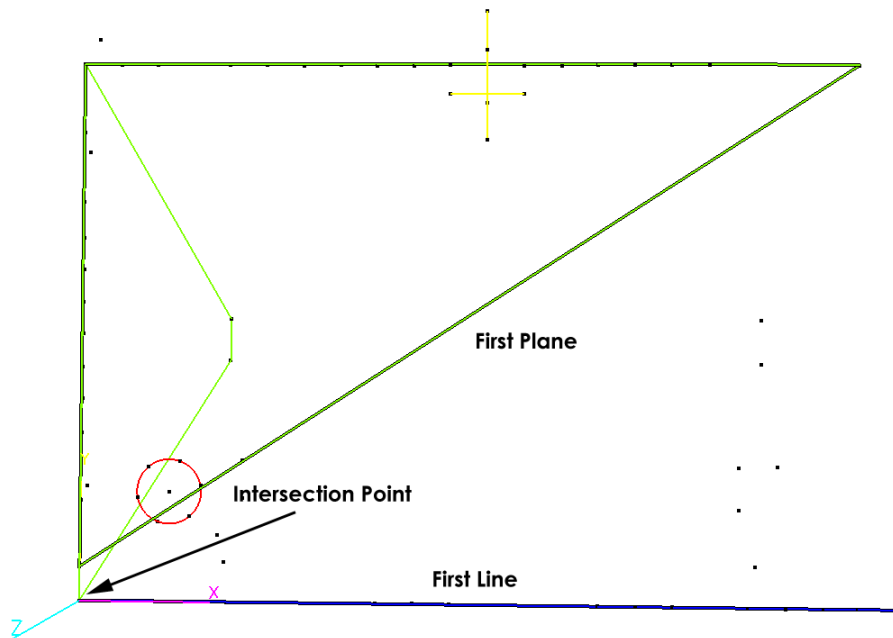

Select **Measure** from the right click **SOLIDS** menu. The **Plane to Line Measurement** dialog is displayed.

This dialog is used to name the measurement and to optionally add the point of intersection between the plane and line (if the two entities are not parallel) to the 3D file.

Press **OK** to add this measurement to the 3D file. Like Plane-to-Plane and Line-to-Line measurements, Plane-to-Line

measurements are stored under the Measurements folder in a folder called Plane-to-Line. Press the Add Point command to add the intersection point.

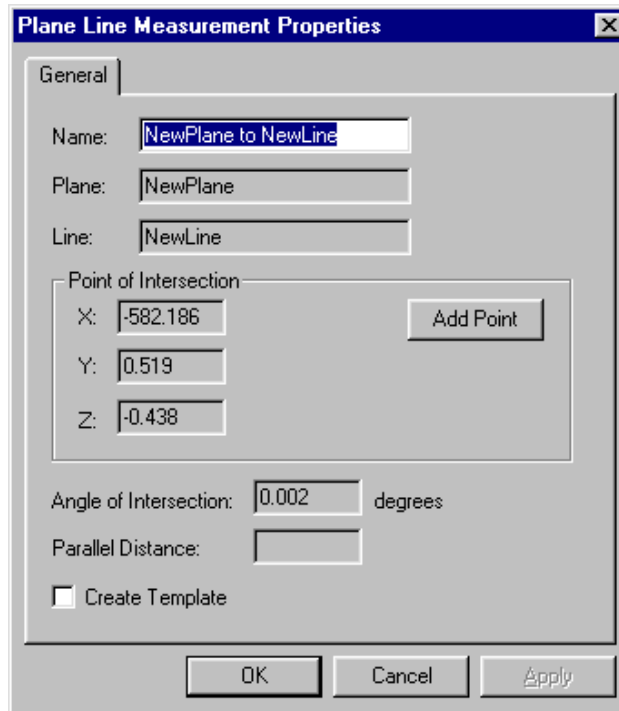

Point to Object

To perform a point to object measurement, select the points and the plane. Select **Measure** from the right click menu. The **Point to Object Measurement** dialog is displayed which shows the point to object distances.

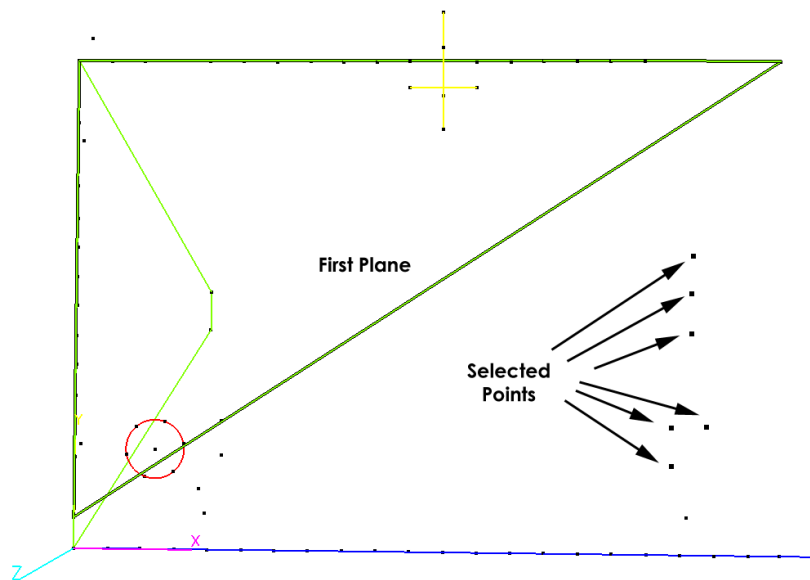

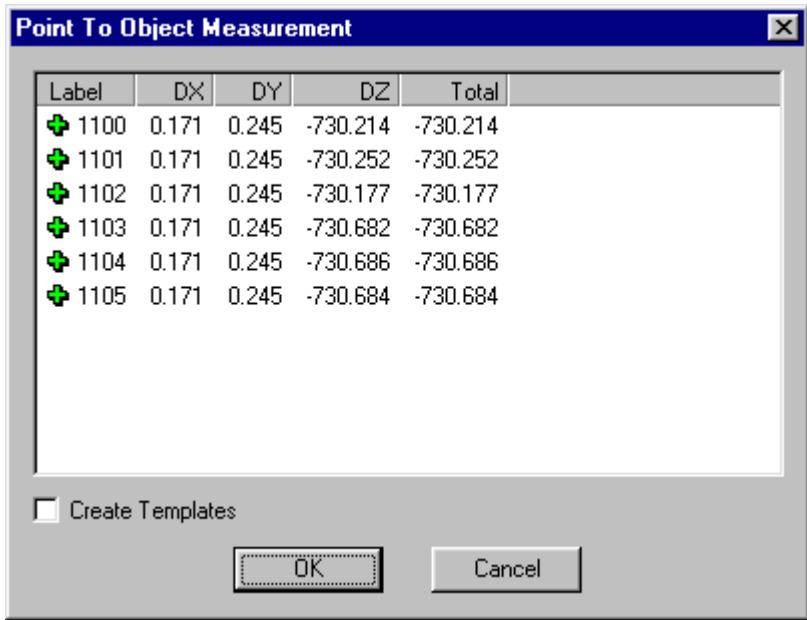

Press **OK** to add these measurements to the 3D file.

To view the results select the relevant plane in the Point to Plane measurements section.

Point Label	Projected X	Projected Y	Projected Z	Delta X	Delta Y	Delta Z	Total
1058	151.461	741.878	-0.017	-0.000	-0.000	0.052	0.052
1059	101.207	742.318	-0.029	-0.000	-0.000	0.034	0.034
1060	50.227	742.018	-0.041	0.000	0.000	-0.017	-0.017
1061	-1.247	743.620	-0.053	-0.000	-0.000	0.053	0.053
1062	-0.507	695.894	-0.068	0.000	0.000	-0.294	-0.294
1063	0.153	648.640	-0.084	0.000	0.000	-0.276	-0.276
1064	-0.375	598.616	-0.101	0.000	0.000	-0.256	-0.256
1065	0.297	551.561	-0.117	0.000	0.000	-0.207	-0.207
1066	0.826	501.696	-0.133	0.000	0.000	-0.215	-0.215
1067	0.850	457.130	-0.148	0.000	0.000	-0.163	-0.163
1068	0.731	412.127	-0.164	0.000	0.000	-0.123	-0.123
1069	1.440	369.004	-0.178	0.000	0.000	-0.111	-0.111
1070	0.591	322.721	-0.194	0.000	0.000	-0.061	-0.061
1071	1.458	279.005	-0.208	0.000	0.000	-0.045	-0.045
1072	1.132	231.906	-0.224	0.000	0.000	-0.042	-0.042
1073	-0.571	184.575	-0.240	-0.000	-0.000	0.013	0.013
1074	0.492	138.272	-0.256	-0.000	-0.000	0.031	0.031
1075	0.068	95.945	-0.270	-0.000	-0.000	0.088	0.088
1076	-0.200	47.552	-0.286	-0.000	-0.000	0.080	0.080
1100	-1.097	372.479	-0.177	0.171	0.245	-730.214	-730.214
1101	-0.675	416.357	-0.162	0.171	0.245	-730.252	-730.252
1102	-1.519	328.600	-0.192	0.171	0.245	-730.177	-730.177
1103	1124.644	418.575	0.102	0.171	0.245	-730.682	-730.682
1104	1124.253	325.925	0.071	0.171	0.245	-730.686	-730.686
1105	1124.448	372.250	0.086	0.171	0.245	-730.684	-730.684

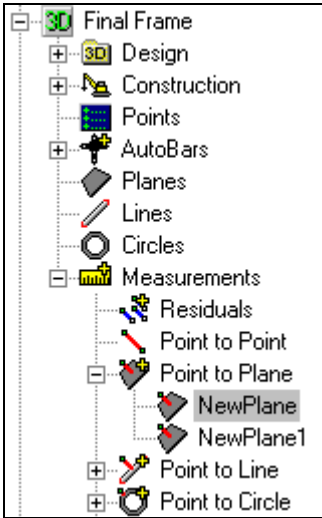

A listing of all the point measurements for this object are displayed. The blue points (1058-1076) are residuals of

the points used to create the object and the green points (1100-1105) are measurements made after the creation of the object.

 When doing a plane, line, circle or sphere fit it is possible for some points to be rejected (their residual is larger than the rejection limit). In this case, V-STARs will add the rejected points to the object as measurements.

Plane Positive Direction

Often before you begin measuring to a plane you will want to define the positive direction. The positive direction allows you to determine which side of the plane you are measuring. The plane shown below has the positive direction pointing up (the line having the color of the plane indicates the positive direction). The measurements are colored to show positive and negative distances. In this case, the color tolerances were set up so red vectors are measurements whose points are "below" the plane (negative total distance) and blue vectors are measurements whose points are "above" the plane (positive total distance). If we were to flip the positive direction of the plane the color of the vectors would reverse.

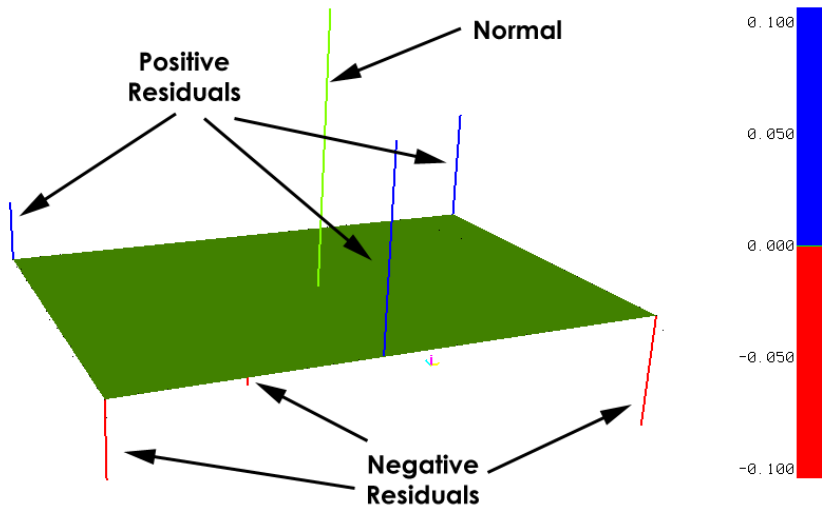

To flip the positive direction of a plane select the plane you want to flip and select the **Flip** command from the **SOLIDS** menu or press the  key.

The positive direction is also used to tell V-STARS in which direction to compensate when a point has an offset. V-STARS always compensates in the opposite direction of the positive direction.

Below we see two examples of the positive direction being used to determine which direction to compensate.

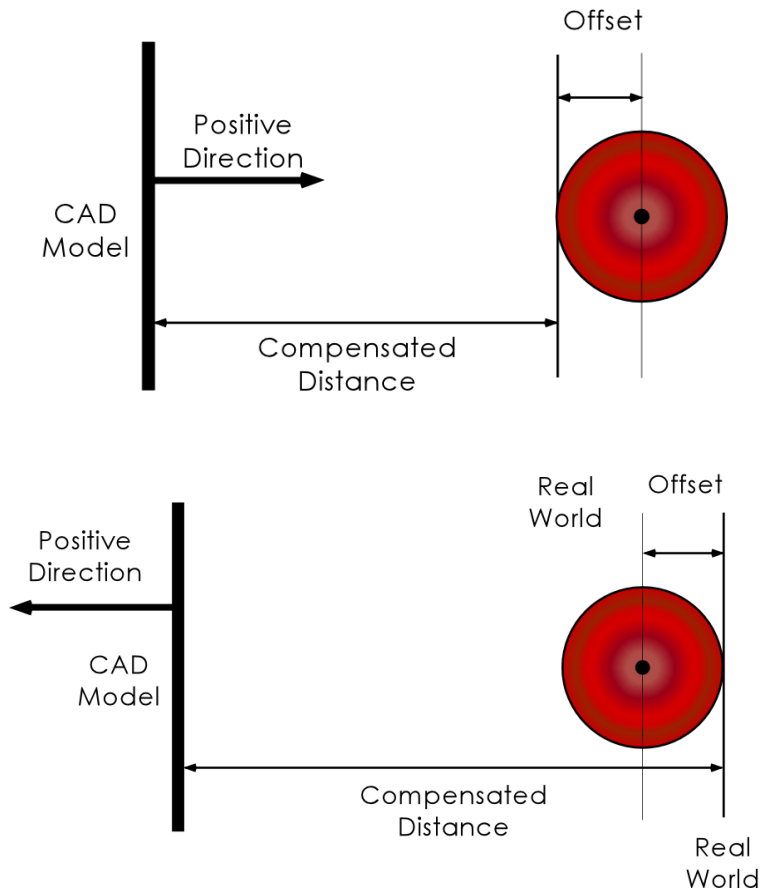

Offsetting Planes

To offset a plane, select the plane you wish to offset and then the **Offset** command from the **SOLIDS** menu. The Offset dialog allows you to specify the distance you wish to offset the plane by. The units of the project are also the units of the offset. The offset will occur in the direction of the normal. Type in a negative value to offset the plane in the opposite direction. The new plane will be named according to the label modification option selected. Check the **Delete Components** box to delete the original plane.

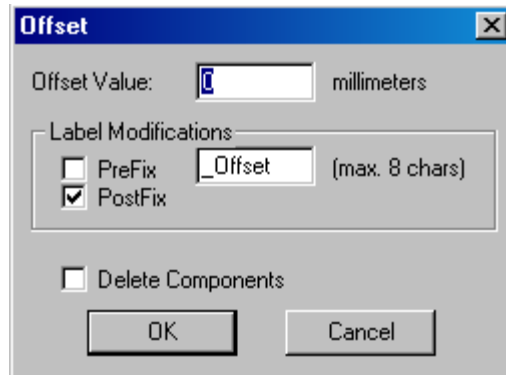

Point to Object Projection

To perform a point to object projection select the plane and the relevant points.

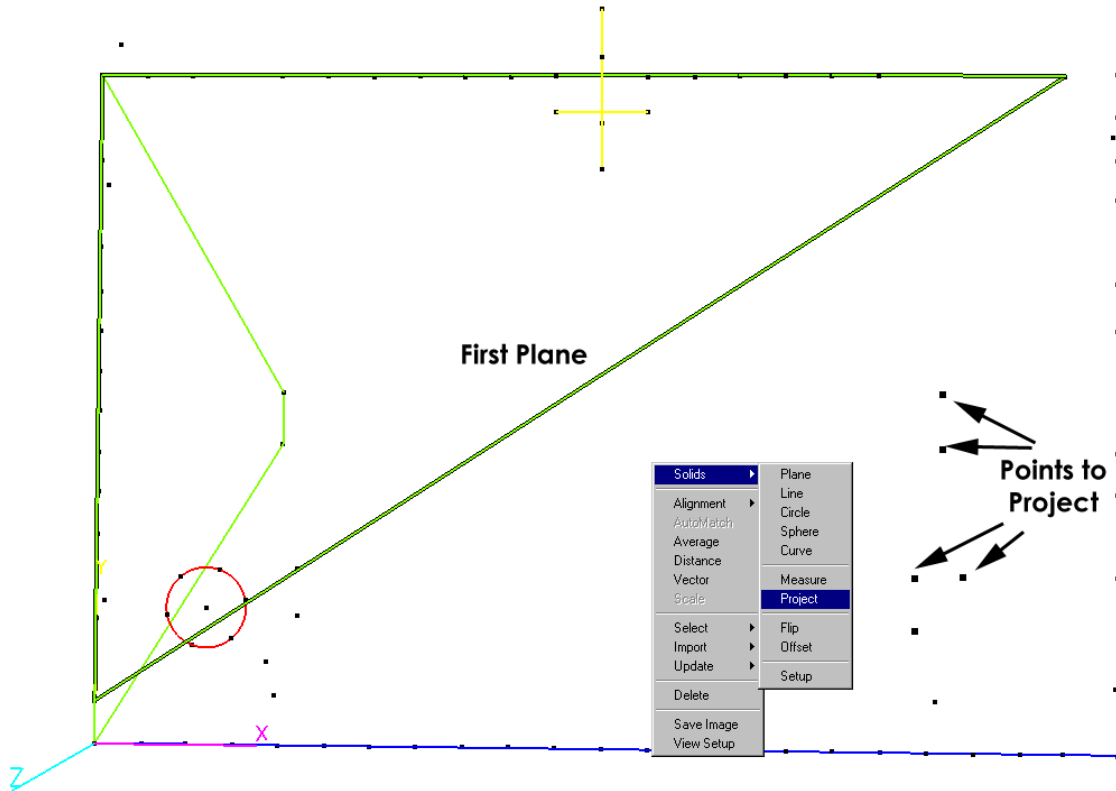

Select **Project** from the right click **SOLIDS** menu.

This dialog allows you to specify the prefix or postfix for the new points. In this case, the new points will have the same label as the old ones but prefixed with "PROJ_". Press **OK** to add the new points to the 3D file.

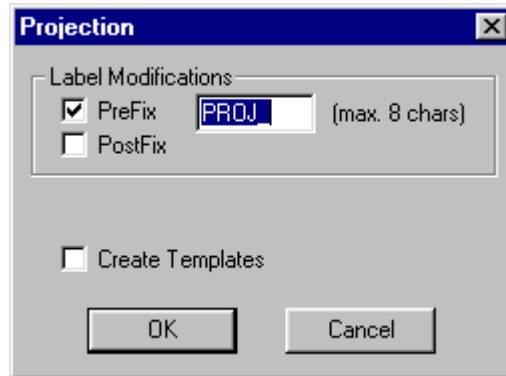

Select the points folder under the relevant 3D file. A listing of the measured points in the 3D file will be displayed. Using the vertical scroll bar, scroll to the newly projected points. Notice that these new points have a different icon  from the other points. This icon is used to mark these points as constructed points and not measured points. Constructed



points are created from other points and objects, while measured points are created by the Bundle.

Point Label	X	Y	Z	Sigma X	Sigma Y	Sigma Z	Offset	
+	C6	93.964	185.233	-0.284	0.008	0.008	0.011	0.000
📐	CIRCLE_AVERAGE	122.797	151.483	-0.529	0.003	0.003	0.004	0.000
📐	CIRCLE_CENTER	122.837	151.491	-0.529	FIXED	FIXED	FIXED	0.000
+	CODE1	8.466	158.495	-0.269	0.007	0.008	0.011	0.000
+	CODE2	8.038	620.050	-0.377	0.007	0.007	0.011	0.000
+	CODE3	1118.771	673.670	-0.063	0.008	0.008	0.013	0.000
+	CODE4	1120.038	72.427	-0.283	0.008	0.010	0.016	0.000
+	CODE6	963.997	188.556	-31.873	0.008	0.008	0.011	0.000
+	CODE7	180.891	86.572	-32.051	0.009	0.008	0.012	0.000
📐	PROJ_SHINY1	910.607	186.278	-0.026	FIXED	FIXED	FIXED	0.000
📐	PROJ_SHINY2	910.272	128.373	-0.046	FIXED	FIXED	FIXED	0.000
📐	PROJ_SHINY3	910.027	86.280	-0.060	FIXED	FIXED	FIXED	0.000
📐	PROJ_WHITE0	214.364	239.200	-0.172	FIXED	FIXED	FIXED	0.000
📐	PROJ_WHITE1	214.835	191.308	-0.188	FIXED	FIXED	FIXED	0.000
📐	PROJ_WHITE2	215.348	139.207	-0.205	FIXED	FIXED	FIXED	0.000
+	SCALE1	13.834	781.931	-14.227	0.008	0.008	0.011	0.000
+	SCALE2	1131.413	782.548	-12.478	0.008	0.008	0.011	0.000
+	SCALE3	193.255	52.014	-19.158	0.008	0.008	0.011	0.000
+	SCALE4	929.884	52.132	-18.054	0.008	0.008	0.011	0.000
+	SHINY1	910.615	186.288	-31.949	0.008	0.008	0.011	0.000
+	SHINY2	910.279	128.383	-32.101	0.008	0.008	0.011	0.000
📐	SHINY3	910.035	86.291	-32.212	0.016	0.015	0.021	0.000
📐	WHITE0	214.371	239.211	-31.378	0.018	0.017	0.024	0.000
+	WHITE1	214.843	191.318	-31.652	0.008	0.008	0.011	0.000
+	WHITE2	215.355	139.217	-31.950	0.008	0.008	0.011	0.000

Point to Curve

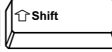

Point to curve measurements can be made as if the curve were just like any other V-STARS Solids object.

Another type of measurement may also be made using curves. A curvilinear distance is the distance between two points along a curve. To create a curvilinear distance measurement, first select the two points in the graphical view (these points must be able to project to the curve) and then select the curve.

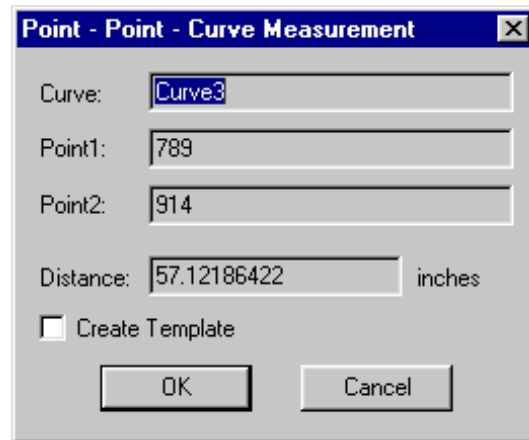
Press   . A dialog box will be displayed showing the result.

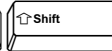

A curvilinear distance measurement may also be made by selecting two curves that intersect a third. First, select the two intersecting curves. Then select the curve along whose distance you wish to measure. Press

  . You will then be prompted with a similar

dialog box, but this time you will

have to fill in the names of the two intersecting points. This will compute the curve distance between the two intersection points.

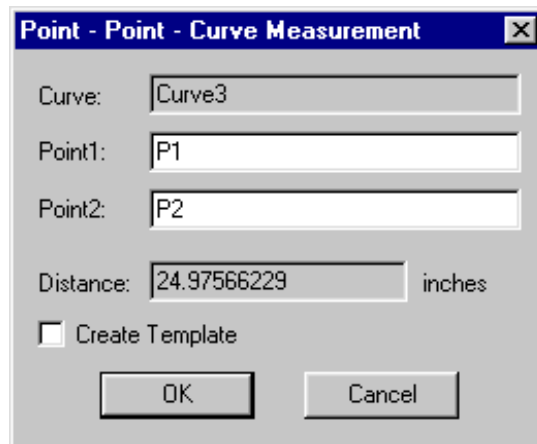

Surfaces

V-SURF is sold as a separate add-on to V-STARS. Please contact GSI for more information.

Introduction

V-SURF is V-STARS' built-in surface analysis module. Using V-SURF, you can measure point to surface deviations while in S-Mode or M-Mode.

Importing

Since V-STARS lacks the ability to create surfaces at this time, you must import them from an external CAD package. To import a surface to V-STARS you must first export the surface to an IGES file using your CAD package. V-STARS can only interpret NURBS Surfaces (IGES entity type 128), be sure your CAD package is set to export surfaces as NURBS. Refer to your CAD documentation for more information. From within V-STARS you may now import this IGES file as you would any 3D file.

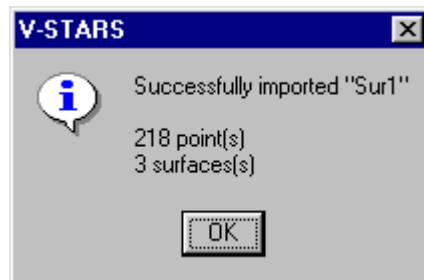
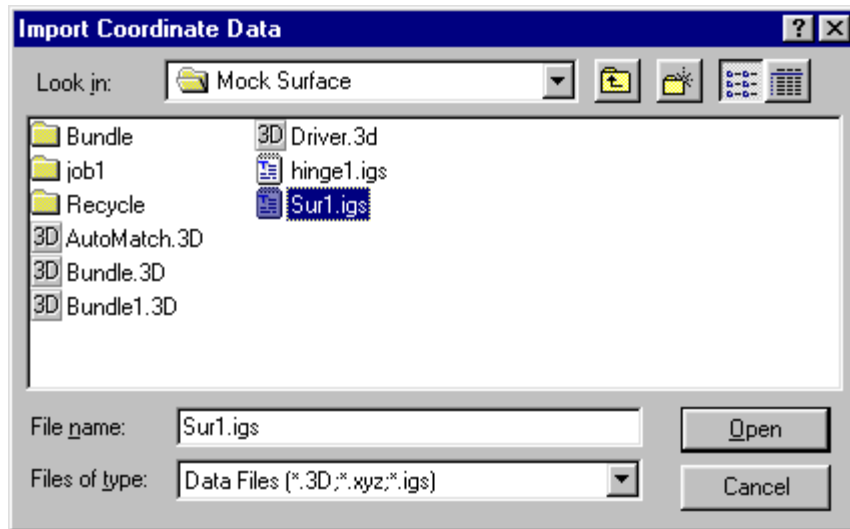

Terminology

For the purposes of display, all surfaces within V-STARS are displayed using a series of lines, called strokes. Each stroke is divided into a series of points called resolutions.

The three surfaces below are displayed using a grid of 4x4 strokes. Each stroke has a resolution of 25, meaning there are 24 individual line segments per stroke.

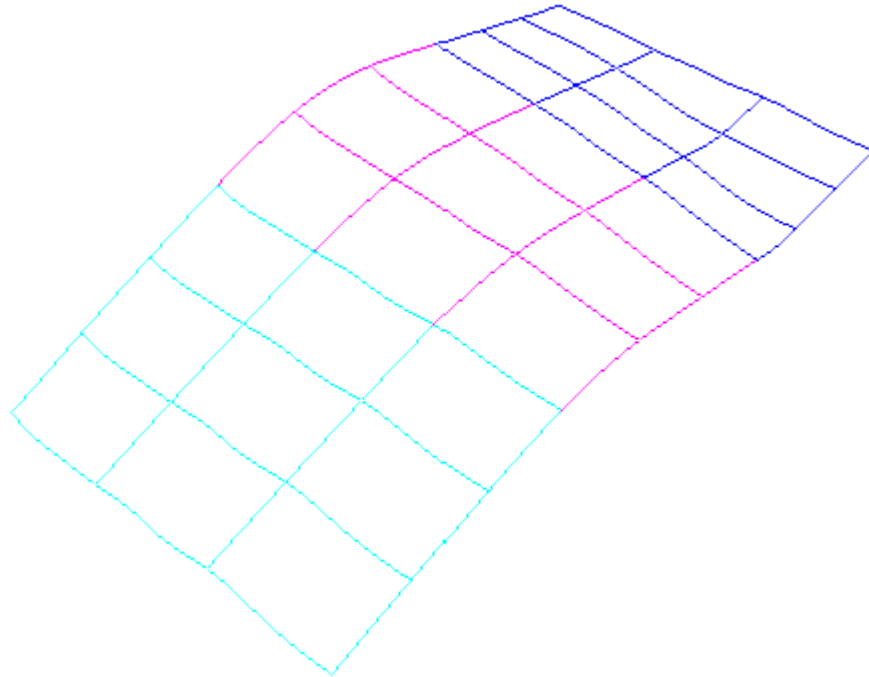



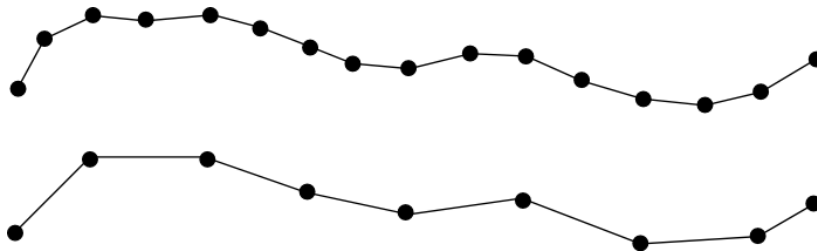





Below is a diagram showing two strokes. The first has a resolution of 15 and the second a resolution of eight. Both will produce the same result, but one is a more realistic visualization of the surface.



As the number of strokes and their resolution is increased, the displayed surface will look more realistic. However, this also requires more memory and greater processor power. Remember that the stroke and resolution only determine how the surface is displayed and not how the surface is defined.

Previous versions of V-STARS used the strokes to find approximate coordinates for surface measurement. As of version 4.1 SR2, this is no longer the case. V-STARS will find the measurement approximation automatically without any intervention.

While in the graphical view you may increase or decrease the stroke of a surface by holding the   or   respectively. You may increase or decrease the resolution by holding the   or   respectively. If no surfaces are selected then the change affects all surfaces; otherwise, only the selected surfaces will be affected.

Commands

If you have a **V-SURF Surfaces license** but do not have a **SOLIDS license** the following right click menu will be available to you in the graphical view and the points list.

If you do have a **SOLIDS license** as well as a Surfaces license then you can access the surface functions from the SOLIDS sub menu.

The three commands available to use with surfaces are **Measure**, **Project** and **Flip**. The **Measure** command will measure the selected points to the selected surfaces. The **Project** command will create new points by projecting existing ones onto a surface. The **Flip** command will change the positive direction of a surface.

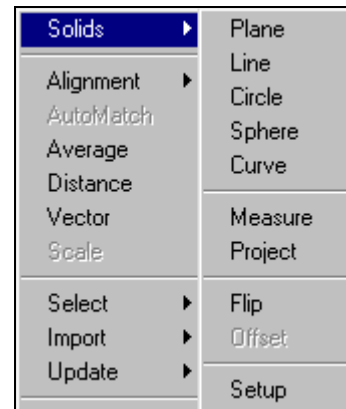
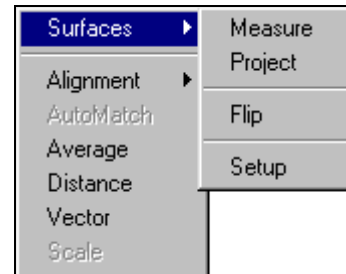

Measurement

The measurement functions for surfaces work the same way that the SOLIDS functions work. As surfaces have boundaries, (unlike planes and lines) it is sometimes impossible for a point to measure to a surface.

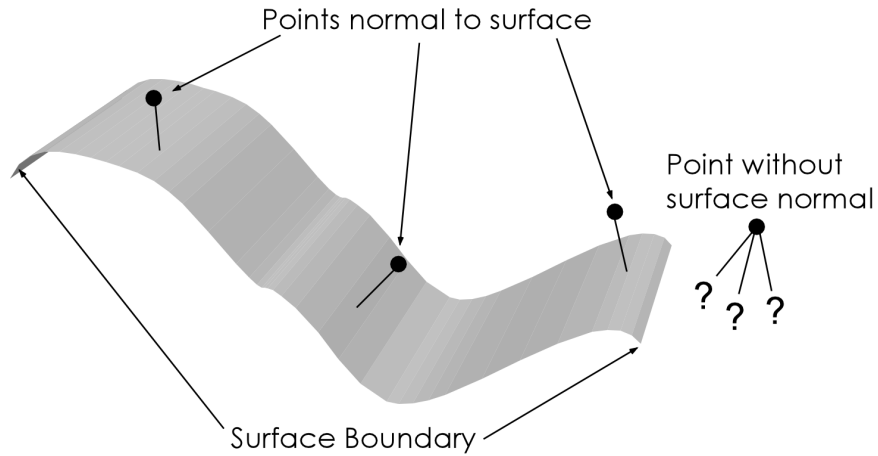

Below we see some selected points and a selected surface.

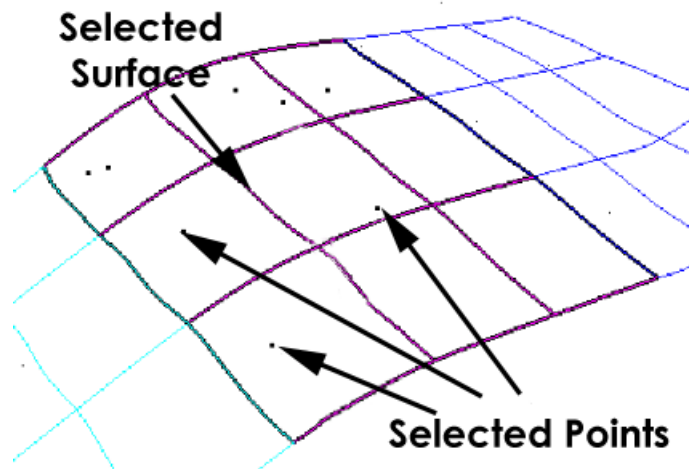

After selecting the measure command, we are presented with the **Surface Measurement** dialog.

This dialog allows you to specify the way V-STARS will make the measurement. This particular dialog indicates that V-STARS will measure the selected points to the closest selected surface. If we had selected more than

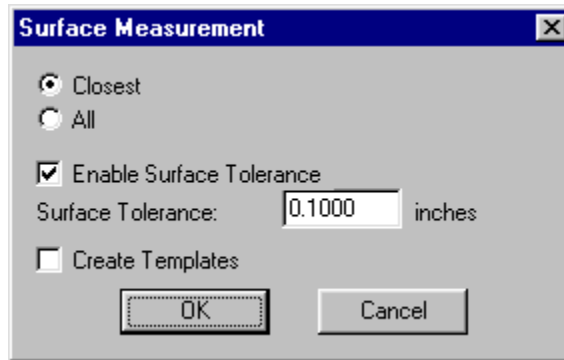

one surface and a particular point could be measured to multiple surfaces only the closest surface would be measured. It is also shown that the surface tolerance is enabled. This will only allow points that are within the tolerance (0.1 inches in this example) to be measured. You will also notice that there is a **Create Template** check box. If this box is checked then V-STARS will also create a measurement template object. Refer to [Construction Objects](#) section for more information.

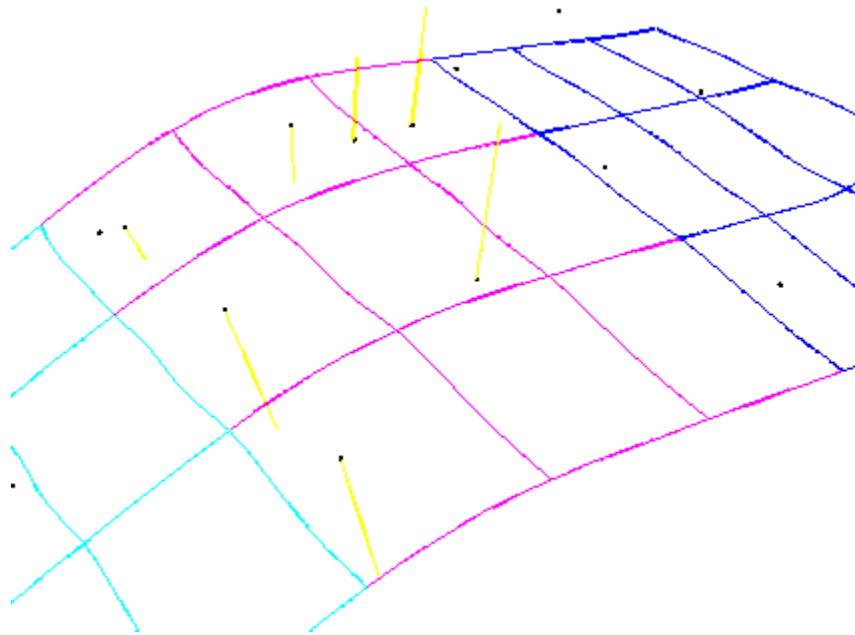

Here we see that the selected points are now measured to the surface. The vectors shown are multiplied by a factor of 1000. If one of the selected points could have been measured to more than one surface and the Closet radio button was selected then we would have been presented with the following dialog.

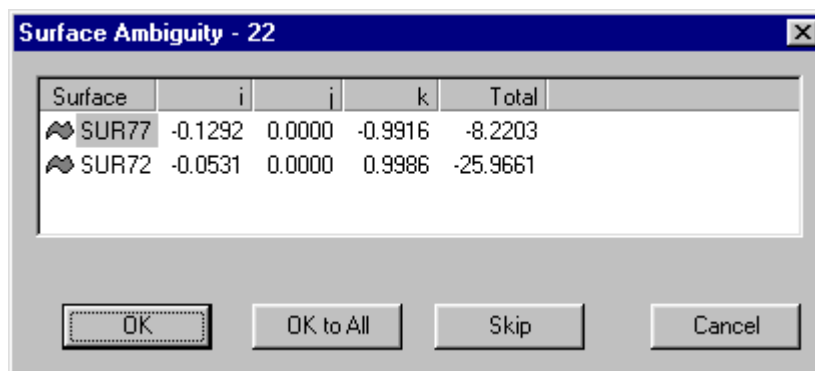

The Surface ambiguity dialog lets you know that the point can be measured to more than one surface (within the specified tolerance, if enabled). It shows to which surfaces the point can be measured, the unit

vector of the surface normal at the measurement point and the total distance from the surface. The surfaces are sorted by distance with the smallest listed first and selected. If you press **OK**, the point will measure to the selected surface. If you press **OK to All** then all future ambiguities will be resolved by automatically selecting the surface with the smallest distance. If you press **Skip** then this point is skipped and no measurement is made. If you press **Cancel**, the measurement process is stopped.

Projection

Point to surface projection works just like point to surface measurement. Except instead of a measurement being created a new point is created. After selecting the points and the surface to which they will project, we select the **Project** command and are shown this dialog.

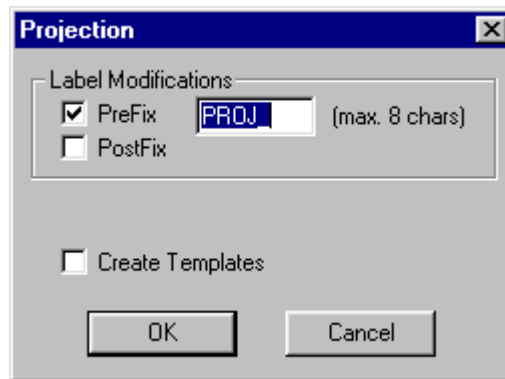

This dialog indicates the new points will have the same label as the existing points but be prefixed with "PROJ_". If the Create Template check box were checked then V-STARS would also create measurement construction templates.

Positive Direction

Often before you begin measuring to a surface, you will want to define the positive direction. The positive direction allows you to determine which side of the surface you are measuring. The surface shown below has the positive direction pointing up (the lines having the color of the surface indicate the positive direction). The measurements are colored to show positive and negative distances. In this case, the color tolerances were set up so red vectors are measurements whose points are "below" the surface (negative total distance) and blue vectors are measurements whose points are "above" the surface (positive total distance). If we were to flip the positive direction of the surface the color of the vectors would reverse.

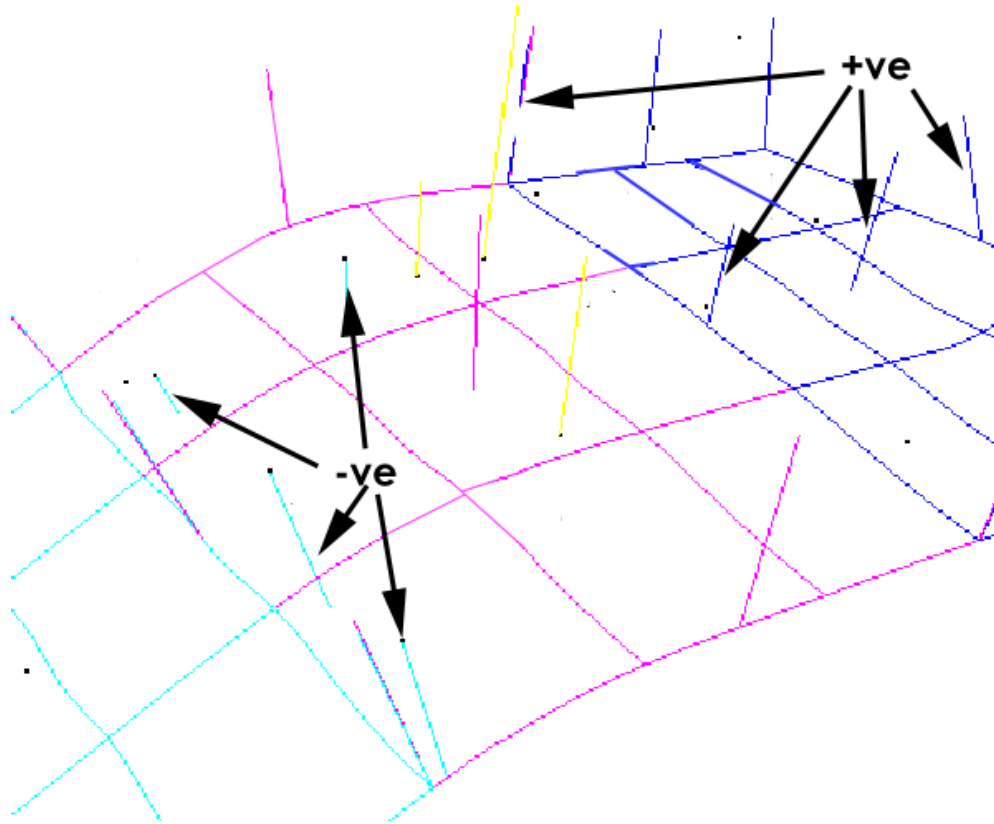

To flip the positive direction of a surface select the surface you want to flip and select the **Flip** command or press the  key.

The positive direction is also used to tell V-STARS which direction to compensate when a point has an offset. V-STARS always compensates in the opposite direction of the positive direction.

Surfaces in the Project

Like the SOLIDS objects, surfaces are listed under their own node on the project tree.

The project tree shown above shows that Bundle1 contains surfaces in the Design area and Sur1 contains surfaces in the Measured area. The advantage of placing surfaces in the design area is that they are not affected by transformations and are copied to the new data file after a bundle. Placing surfaces in the measured area of a 3D file allows them to be affected by the transformation when you do an axis, quick or standard alignment.

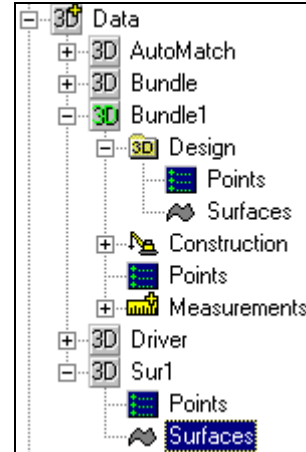

When you select the Surfaces node, a list of the surfaces contained in the 3D file is displayed below.

Name	Stroke	Res	Active	Trimmed
BS SURF	3 x 3	25 x 25	Yes	No
BS SURF_2	3 x 3	25 x 25	Yes	No
BS SURF_3	3 x 3	25 x 25	Yes	No

Double click on a surface in the list to display more information.

This dialog allows you to manually enter a stroke and resolution. You can also activate and deactivate the surface as well as change the color.

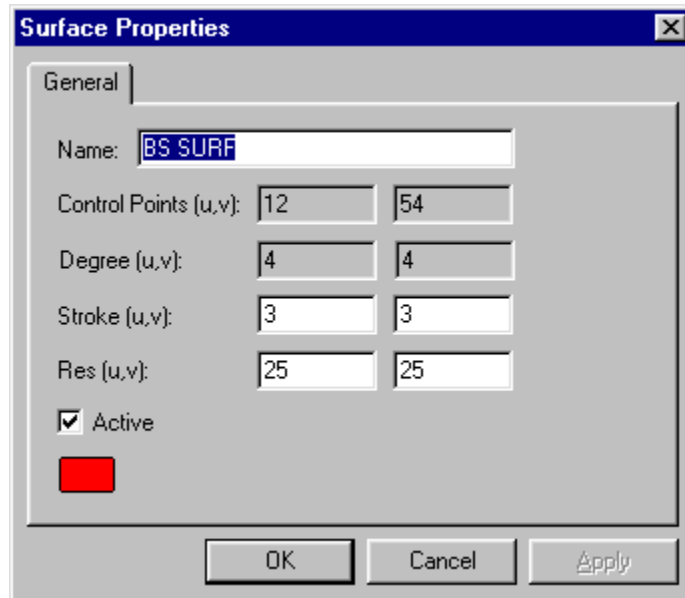

Construction Objects

Introduction

Construction objects allow constructed point and object entities, such as vector points, planes, lines, etc. to be automatically computed at the end of each bundle. For example, say that point 1130 is a vector point. Point 1130 is defined to be 100mm from a targeted-point 130 in the direction of another targeted-point 131. Points 130 and 131 are calculated as a result of the bundle. Point 1130, however, is constructed from 130 and 131. By creating a construction object, you can have V-STARS automatically calculate the point 1130 each time a bundle is run. Similar construction objects are available for planes, lines, circles, sphere and all the objects and measurement types supported by V-STARS and SOLIDS.

 To manually create/update the construction objects after a bundle, right click on the 3D data file and select **Update | Construction Objects** from the pop up menu, or select right click in the graphical view and select **Update | Construction Objects** from the pop up menu.

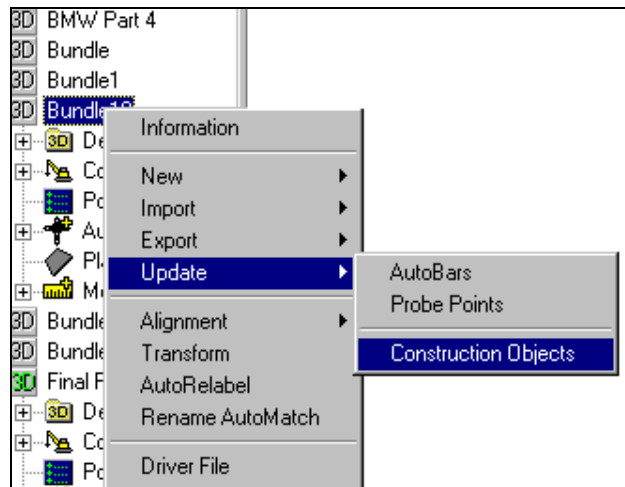

V-STARS will overwrite any existing objects with the newly calculated ones (one exception is with measured points, if a point already exists that was not created by a construction object then that point will not be overwritten).

Construction objects appear as a folder in a 3D file. Currently, V-STARS supports vector point, average point, plane, line, circle, spheres and measurement construction operations.

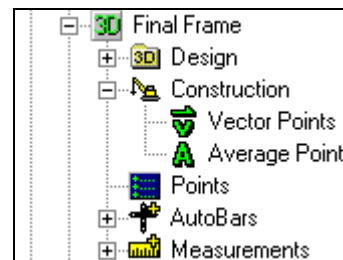

Importing

Like design data, construction objects may be imported from other 3D data files. To import construction data into a 3D file, right click on the file and select **Import | Construction Data**. You will be shown a file open dialog. Select the 3D data file that contains the construction data you wish to import and select **OK**. A summary of the objects imported will be displayed.

Construction Objects.

Vector Points

There are two ways to create a vector point construction object. The first way is create the vector point as you normally would, but make sure the **Create Template** check box is checked before you press **OK**. The vector point as well as the vector point construction object is created and added to the data file.

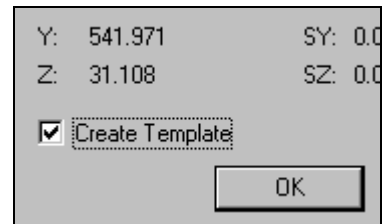

The second way is to create just to construction object. Right click on the 3D file you wish to contain the object and select **New | Construction Object**. Select Vector Point from the list and you will be presented with this dialog.

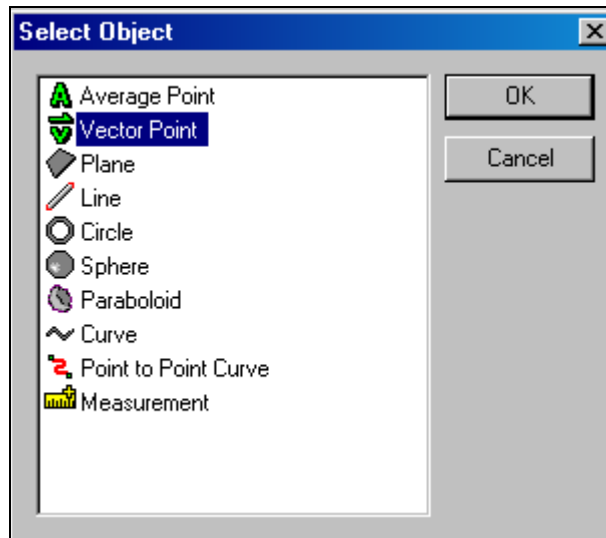

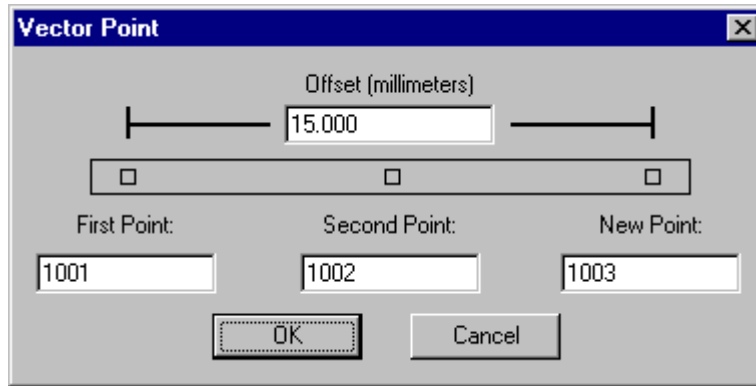

Enter a vector distance in the offset field, a first point label, second point label, new point label. Press **OK** to save the vector construction object.

On subsequent bundle runs, V-STARs automatically recalculates the vector point.

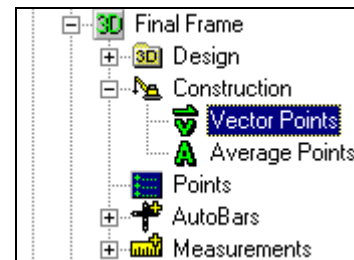

To view and edit existing vector construction objects select Vector Points from the project tree under the Construction branch.

A list of the all the vector construction objects contained in this 3D file is displayed.

Label	Point Label 1	Point Label 2	Distance
+ 1000	1002	1001	100.000
+ SHINY3	SHINY1	SHINY2	100.000
+ WHITE0	WHITE2	WHITE1	100.000

You can double click on an existing vector object to edit it. To create a new vector object right click in the list and select **Add**. To delete an existing vector object right click on the object and select **Delete**.

Average Points

There are two ways to create an average point construction object. The first way is create the average point as you normally would, but make sure the **Create Template** check box is checked before you press **OK**. The average point as well as the average point construction object is created and added to the data file.

The second way is to create it is just like the vector construction object. Right click on the 3D file you wish to contain the object and select **New Construction Object** from the **New** menu. Select Average Point from the list and you will be presented with this dialog.

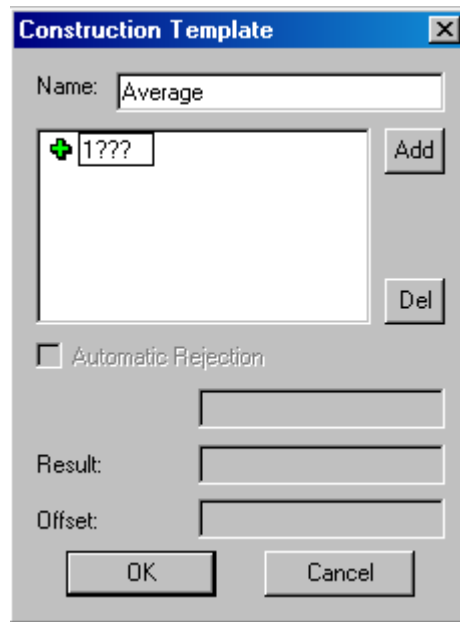
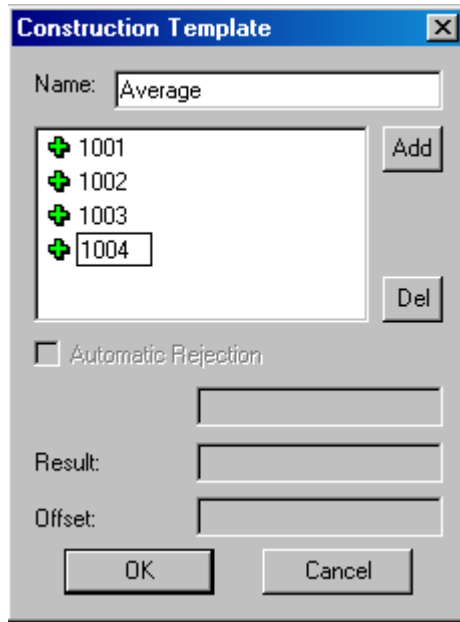

Enter a label for the average point in the name field. To add a new point to the average point construction object, press the **Add** button and type the point label into the edit field (wildcard characters may be used). To remove a point, select it and press the **Del** button. Press **OK** to save the average point construction object. Wild cards can also be used. The first dialog will create a point called Average. It will be the average of the points 1001-1004. The second point will also create a point called Average. It will be the average of all the points in the 3D file that have a label that starts with the number 1 and has another three characters.

On subsequent bundle runs, V-STARs automatically recalculates the average point. In order for the average point to be created, ALL of the non-wildcard point labels must exist in the measured 3D data.

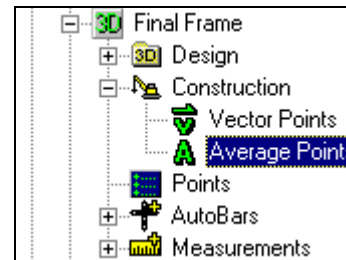

To view and edit existing average construction objects select Average Points from the project tree under the Construction branch.

A list of the all the average construction objects contained in this 3D file is displayed.

Point Label	Labels	WildCards
➤ CIRCLE_AVERAGE	6	0
➤ 1100	2	0
➤ 1105	2	0
➤ 1106	2	0

You can double click on an existing average object to edit it. To create a new average object right click in the list and select **Add**. To delete an existing average object right click on the object and select **Delete**.

SOLIDS Objects

To use any of the SOLIDS construction objects you must have a SOLIDS license.

All of the V-STARS SOLIDS objects can be created using construction templates. As with average and vector points there are two ways to create a SOLIDS construction object. The first way is to create the object as you normally would, but make sure the **Create Template** check box is checked before you press **OK**. The SOLIDS object as well as the construction object is added to the data file.

The second way is to just create the construction object. Right click on the 3D file you wish to contain the object and select **New | Construction Object**. Select Plane, Line, Circle or Sphere from the list and you will be presented with a dialog.

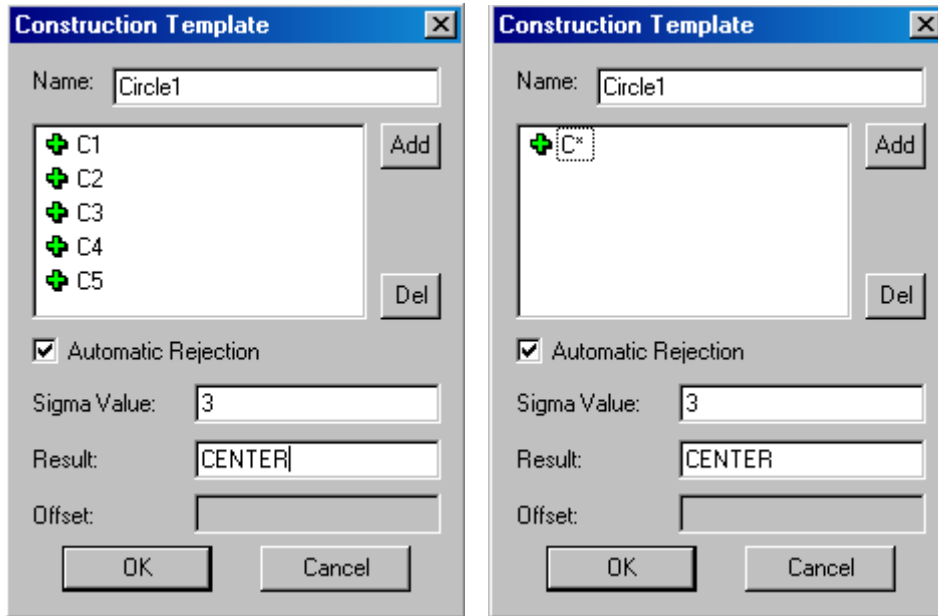

Enter a label for the construction object in the name field. To add a new point to the construction object, press the **Add** button and type the point label into the edit field (wildcard characters may be used). To remove a point, select it and press the **Del** button. Enter a rejection limit to use (-1 means no rejection limit) or check the Automatic Rejection check box and enter a sigma value. If the construction object is a circle or sphere, you can enter a center point label into the result field. If you do not enter the result point label then the center point will not be created. Press **OK** to save the construction object.

The first dialog shows a circle construction object. It will create a circle called "Circle1" using points C1, C2, C3, C4 and C5. It will use a three-

sigma automatic rejection limit. The second dialog will also create a circle called "Circle 1". In this example, any point that starts with "C" will be used to create the circle. It will use a three-sigma automatic rejection limit and create a center point called CENTER.

On subsequent bundle runs, V-STARS automatically recalculates the object. In order for the object to be created, ALL of the non-wildcard point labels must exist in the measured 3D data.

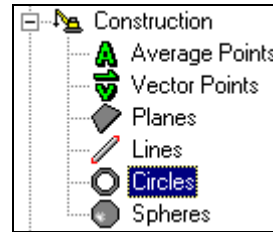

To view and edit existing construction objects select Plane, Line, Circle or Sphere from the project tree under the Construction branch.

A list of the all the circle construction objects contained in this 3D file is displayed.

Name	Labels	Wildcards	Center
Circle1	5	0	C0
Circle2	5	0	N/A
Circle3	0	1	A0

The center column lists the name of the center point to construct and is displayed only if you are viewing circle or sphere construction objects. If no center point is to be created, N/A is displayed. You can double click on an existing construction object to edit it. To create a new construction object right click in the list and select **Add**. To delete an existing construction object right click on the object and select **Delete**.

Measurement Objects

To use any of the measurement objects that use SOLIDS objects or Surfaces you must have a SOLIDS and/or Surface license.

Any object measurement that can be made using V-STARS can be created using construction templates. As with other construction objects there are two ways to create a measurement construction object. The first way is to create the measurement as you normally would, but make sure the **Create Template** check box is checked before you press **OK**. The measurement as well as the measurement construction object is added to the data file.

The second way is to create just to measurement construction object. Right click on the 3D file you wish to contain the object and select **New | Construction Object**. Select Measurement from the list and you will be presented with this dialog.

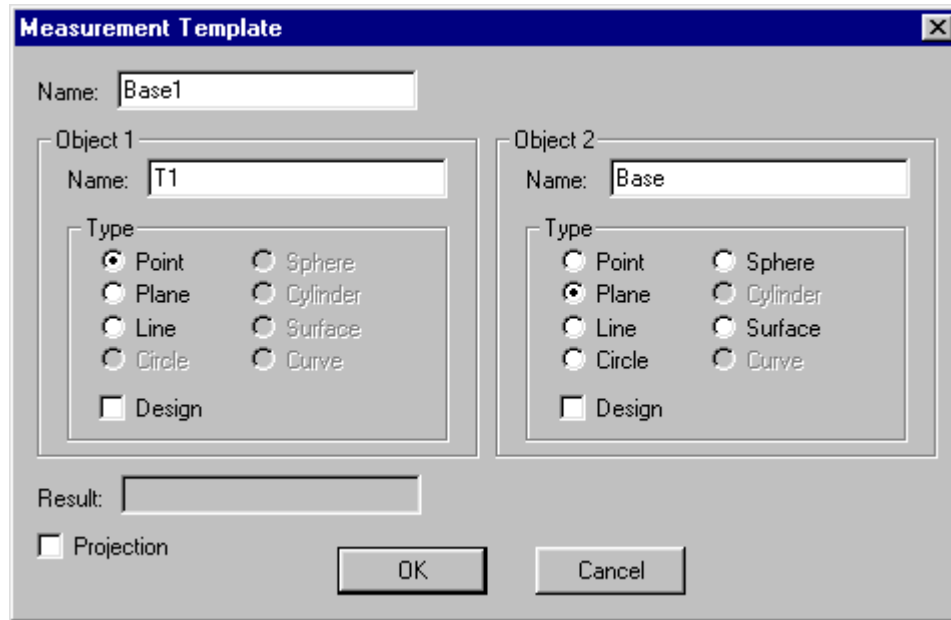

Enter a label for the measurement construction object in the name field. Enter the name for the first object and select its type. Enter the name for the second object and select its type. If either of the objects are design objects then check the Design check box. If the type of measurement defined by the two objects can produce a result object, (a plane to line measurement can produce a point of intersection) enter the result name in the result field. If you do not enter the result name then the result object will not be created.

The first dialog shows a point to plane measurement construction object. It will create a point-to-plane measurement called Base1 using point T1 and plane Base.

The dialog below shows a plane-to-plane measurement construction object. It will create a plane-to-plane measurement called FrontBase using plane Front and plane Base. It will also create the line of intersection called FrontBase.

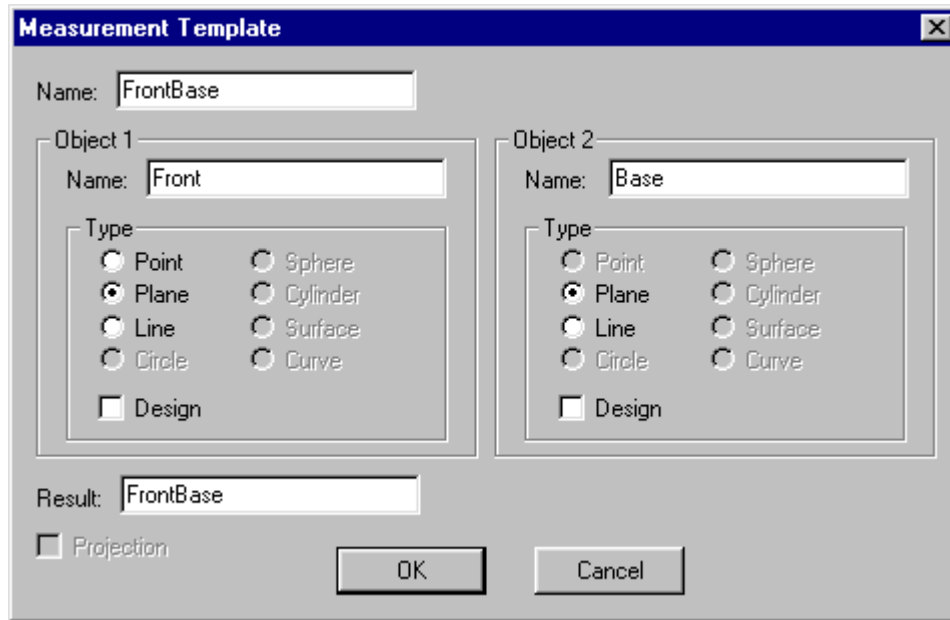

The dialog below shows a point to plane projection construction object (notice that the Projection check box is checked). It will create a new point called T1_PROJ by projecting point T1 to the plane Front.

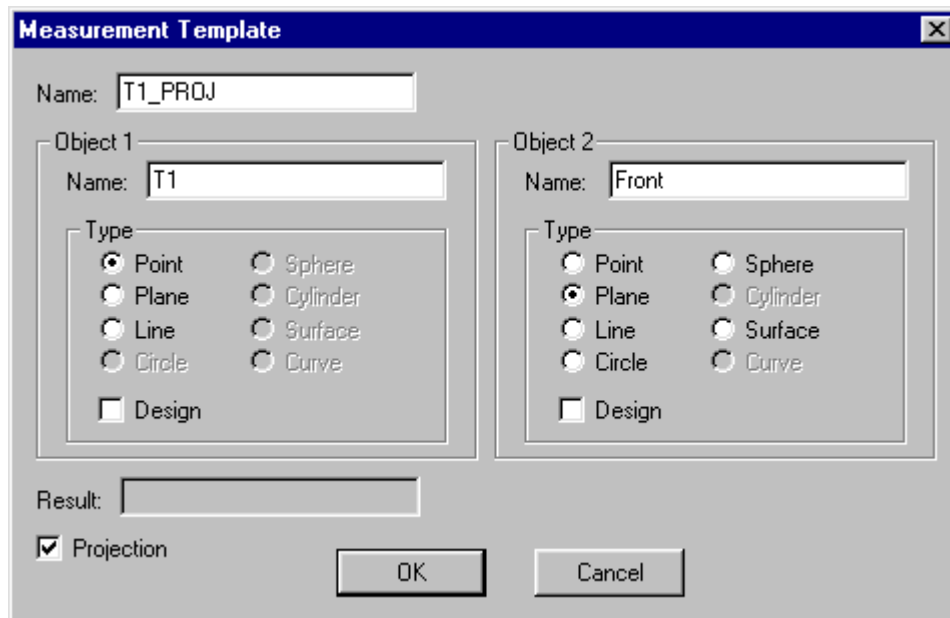

On subsequent bundle runs, V-STARS automatically recalculates these objects. The objects can also be created using the [Update Command](#) under the Graphical View right click menu.

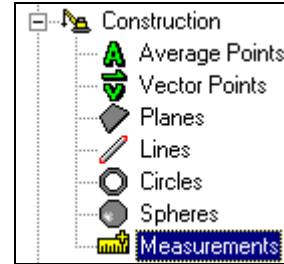

To view and edit existing construction objects select Measurements from the project tree under the Construction branch.

A list of the all the measurement construction objects contained in this 3D file is displayed.

Name	Object1	Type1	Object2	Type2	Result	Project
BASE_L1002 PROJ_BASE_L1002	BASE_L1002	Point	PROJ_BASE_L1002	Point	N/A	No
BASE_L103 PROJ_BASE_L103	PROJ_BASE_L103	Point	BASE_L103	Point	N/A	No
BASE_LA202	LA202	Point	Base	Plane	N/A	Yes
PROJ_BASE_LA202	BASE_LA202	Point	L100	Plane	N/A	Yes
B602	B602	Point	Line1	Line	N/A	No
B604	B604	Point	Line1	Line	N/A	No
B201	B201	Point	Circle1	Circle	N/A	No
B202	B202	Point	Circle1	Circle	N/A	No
B803	B803	Point	Sphere1	Sphere	N/A	No
B804	B804	Point	Sphere1	Sphere	N/A	No
L1900 to Base1	L1900	Plane	Base1	Plane	L1900 to Base1	No
L700 to Base1_1	L700	Plane	Base1	Plane	N/A	No

Shown above are several different types of measurement constructors. The Name column contains the name of the measurement. The Object columns contain the names of the involved objects and the Type column contains the type of objects involved. The Result column contains a measurement result (plane to plane measurement L1900 of Base1 creates a line called L1900 to Base1). The Project column indicates if the measurement is a projection. Measurement BASE_LA202 is a point to plane projection. Point LA202 will be projected to plane Base and the newly projected point will be called BASE_LA202. You can double click on an existing construction object to edit it. To create a new construction object right click in the list and select **Add**. To delete an existing construction object right click on the object and select **Delete** or press the key.

Reports

Introduction

V-STARS has the ability to generate an ASCII report of measurements and SOLIDS analysis. The Report and Report Setup commands can be found under the **File** menu option. Reports provide a way for you to save ASCII text file representations of 3D coordinate data files.

Setup

To setup which entities are included in a report select **Report Setup** from the **File** menu.

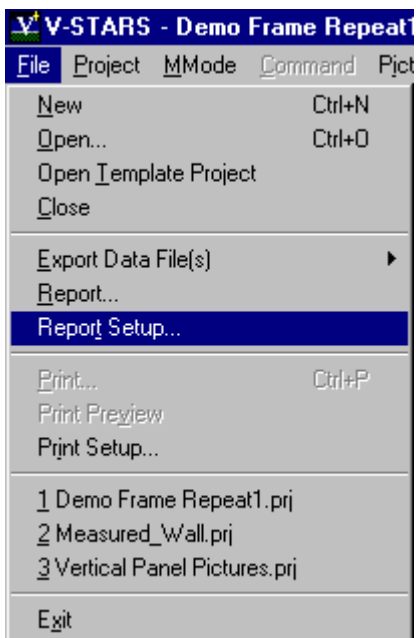

The Report Setup dialog appears.

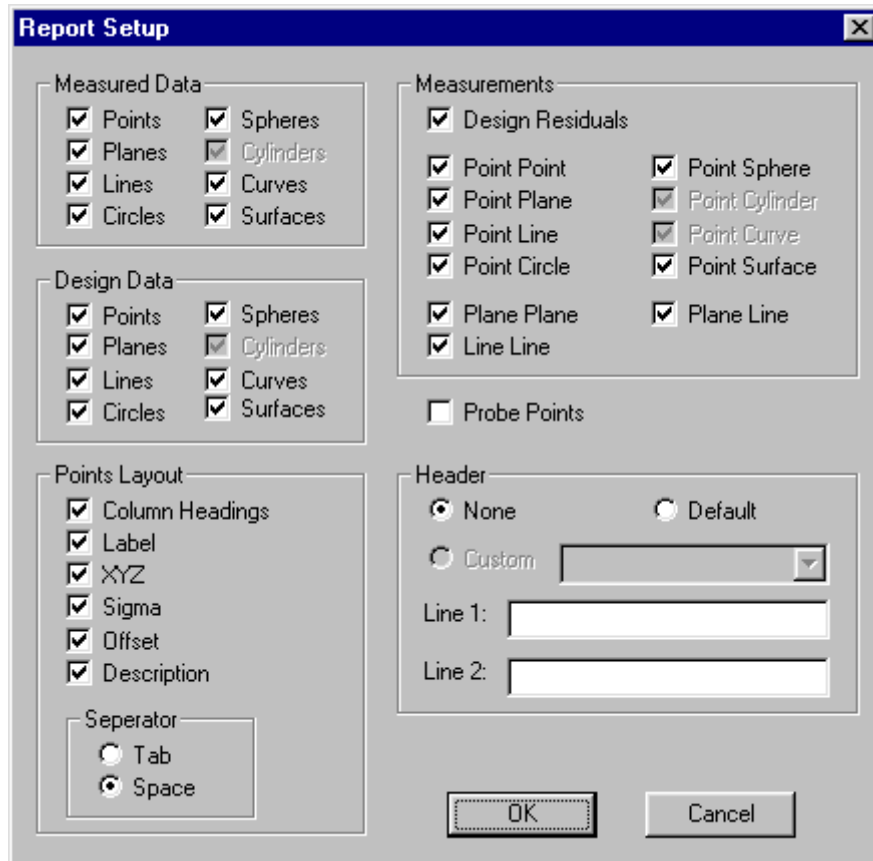

Use this dialog to select the different entities to be included in the report. In addition, you can select the report header file to use.

 Use the Tab separator if you wish to import the report file directly into Excel.

Creating Reports

Select **Report** from the **File** menu to generate a report.

The **Select Data Set(s)** dialog appears

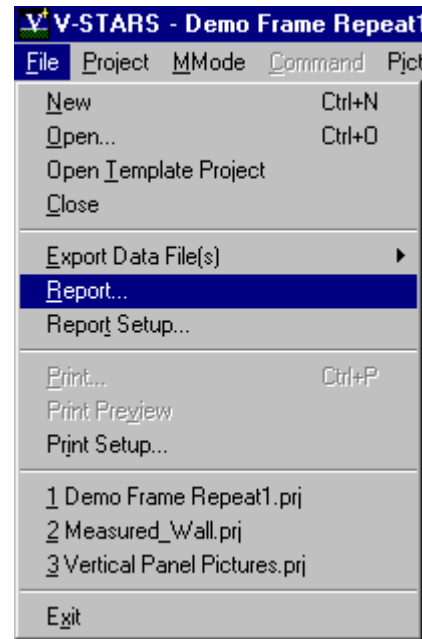
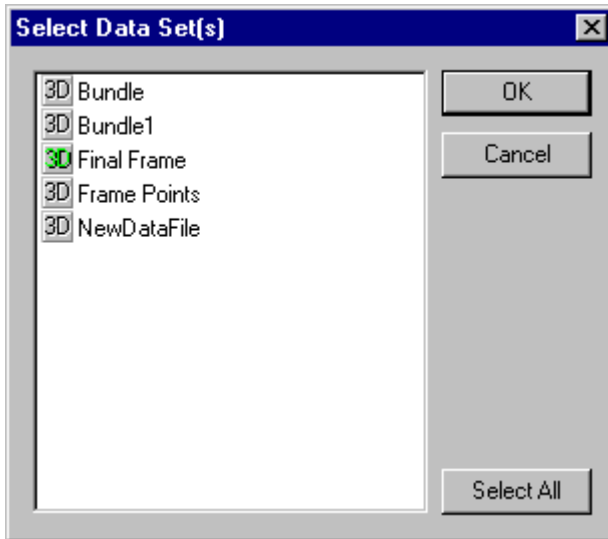

Select one or more 3D files and press **OK**.

For each selected file, the **Save As** dialog appears prompting you for a report file name.

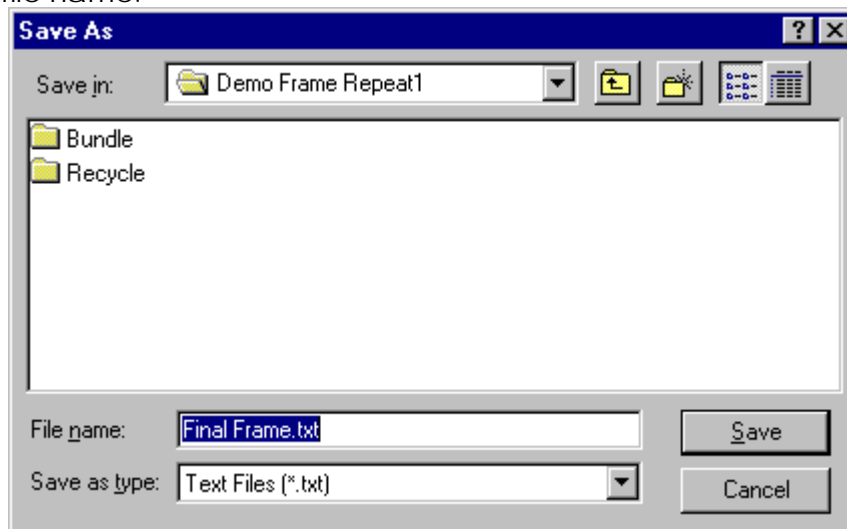

Enter a report file name and press the **Save** button to save the report.

%end%	Early End Of File: must be the FIRST text in a line. This key marks and early end of file. All after this keyword are ignored.
%logo%	V-STARS logo
%version%	V-STARS software version number
%project%	V-STARS project name
%name%	The name of the object (i.e. - Bundle)
%filename%	The name of file (i.e. - Bundle.3D)
%fullfilename%	The name full file name including path (i.e. - C:\Bundle.3D)
%units%	The units the file is in (i.e. - inches, meters, etc...)
%accuracy%	The accuracy used for sigma values (i.e. - U99, three sigma)
%date%	Today's date (i.e. - May 10, 1996)
%time%	Current time (i.e. - 2:25:11 PM)
%time24%	Current 24 hour/military time (i.e. - 14:25:11)



All keywords are case insensitive

File Menu

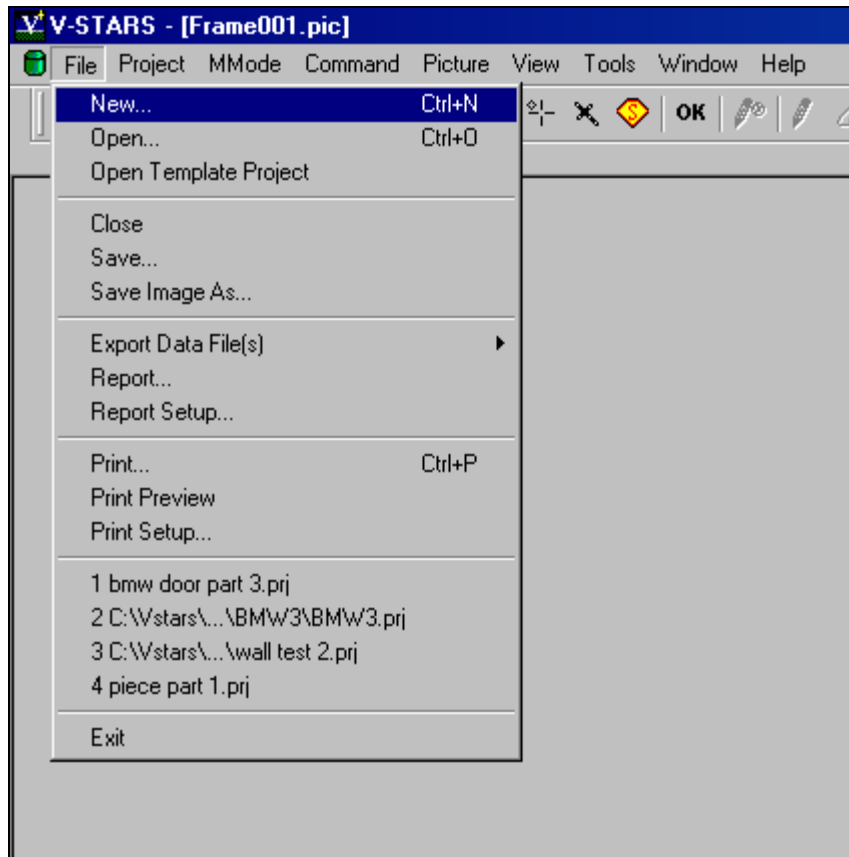

New Project

Refer to [New Project](#) in the Starting a V-STARS Project section for an explanation of how to start a new project.

Open Project

Refer to [Open Project](#) in the Starting a V-STARS Project section for an explanation of how to open an existing project.

Open Template Project

Refer to [Open Template Project](#) in the Starting a V-STARS Project section for more information on Template Projects.

Close

The **Close** command will close the existing V-STARS project. A save of the V-STARS project is carried out automatically upon closing. All the window positions, and settings will be saved in the local GSI32.ini file.

Save

The **Save** command will update the existing V-STARS GSI32.ini file and any other files that have been modified.

Save Image As

The **Save Image As** command is only active when an image is open. It will save/convert an image as a GSI, TIFF, BMP or DIB format file. Select the file that needs to be converted and set the file type by setting the file extension.

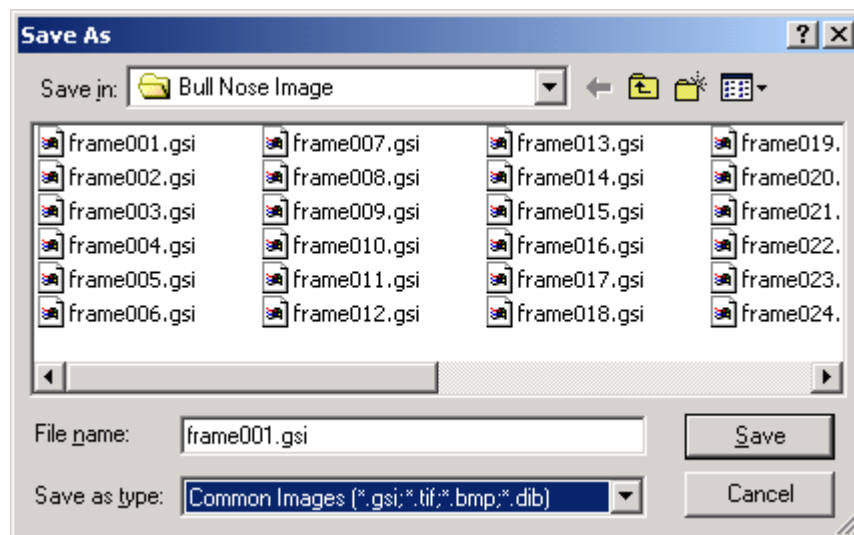

Export Data Files

The **Export Data Files** command will export a V-STARS 3D file into one of a number of third party software file formats. Some of these formats will only be active when a current driver is available. This is due to the particular file format expecting a direction vector for each point. This direction vector is derived from the camera positions.

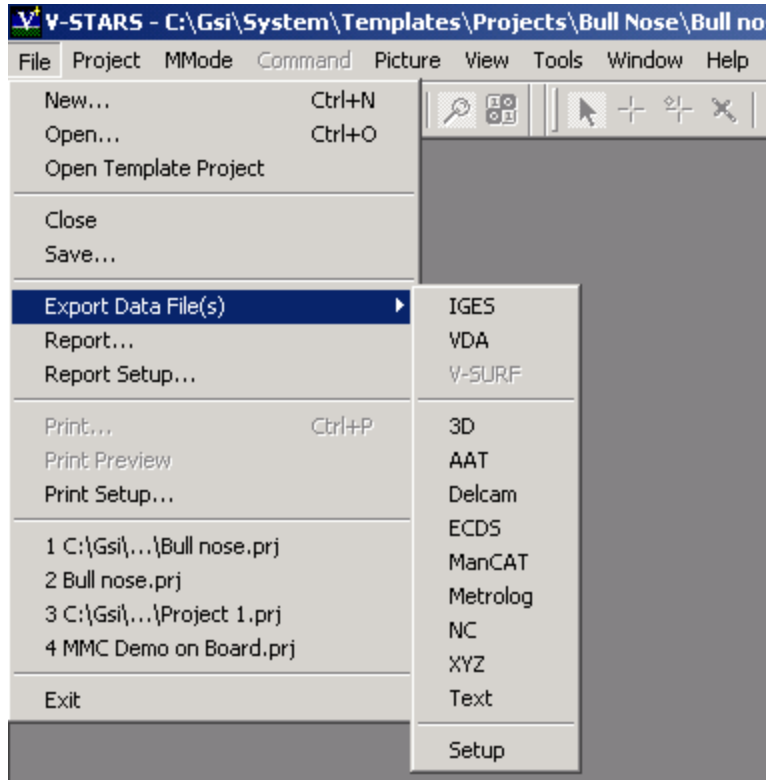

Depending on whether the export format requires the directional vector or not, one of two dialogs will appear. The first automatically selects the driver and adds the appropriate extension.

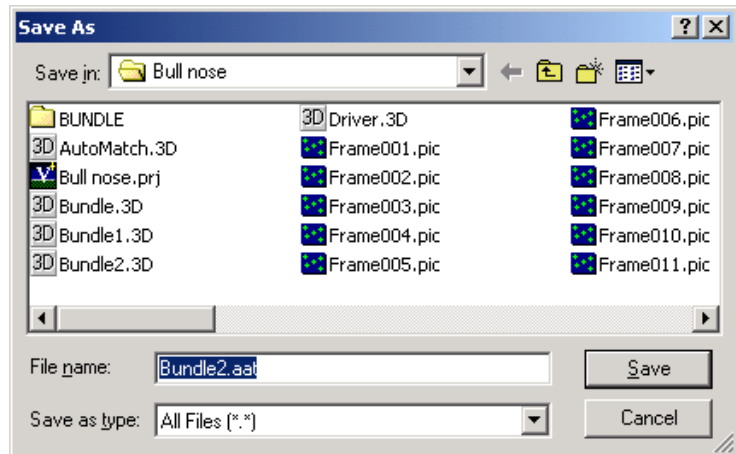

The second allows you to select the file or files they wish to export.

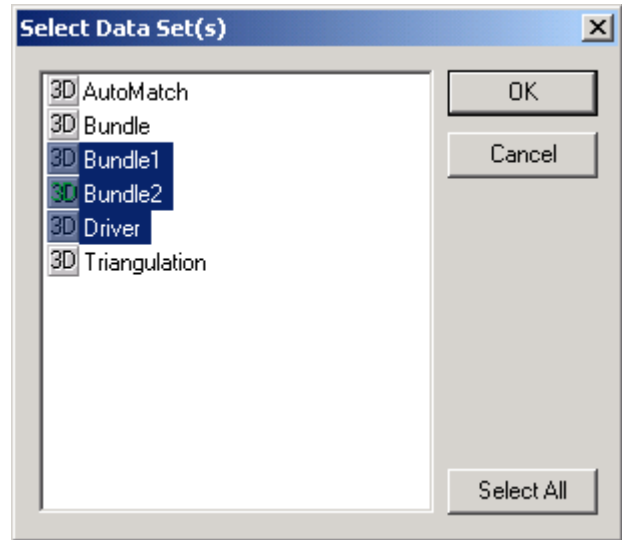

The **Export Data** Files option also has a Setup dialog. This dialog can be used to modify the manner in which Text and V-SURF data is saved.

The Text export setup is shown in the adjacent image.

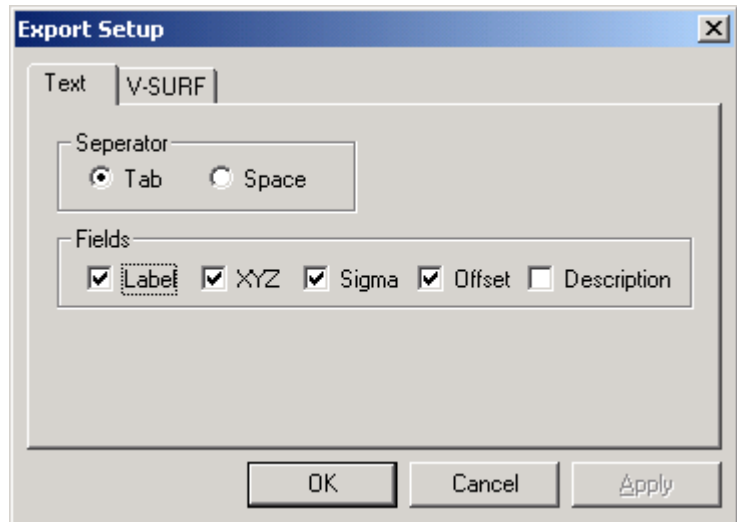

The V-SURF export setup is shown in the adjacent image.

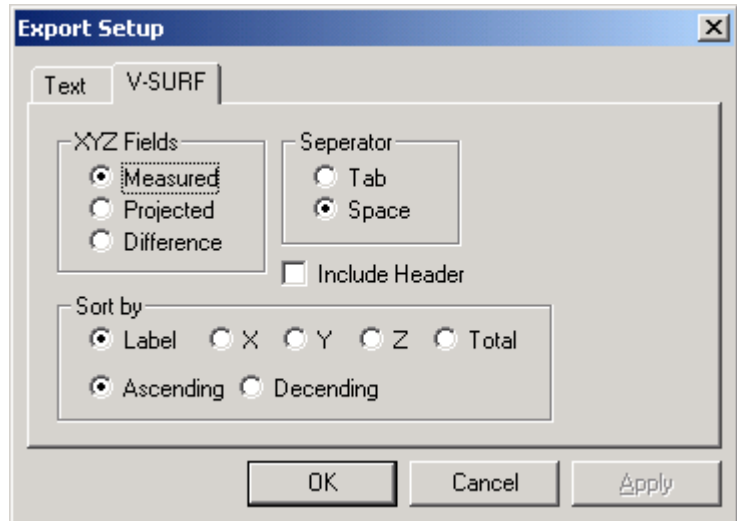

Report

The **Report** command will create a report for any of the 3D files in the project. You can customize what they want to report. This is done in the **Report Setup**. The report is a useful way to summarize almost all of the collection, alignment and analysis carried out in a project. Refer to the [Report Section](#) of the manual for more information.

Report Setup

The **Report Setup** command is used to customize the format of the report. The dialog is shown below. You just have to simply modify the form so that it meets your output requirements. Refer to the [Report Section](#) of the manual for more information.

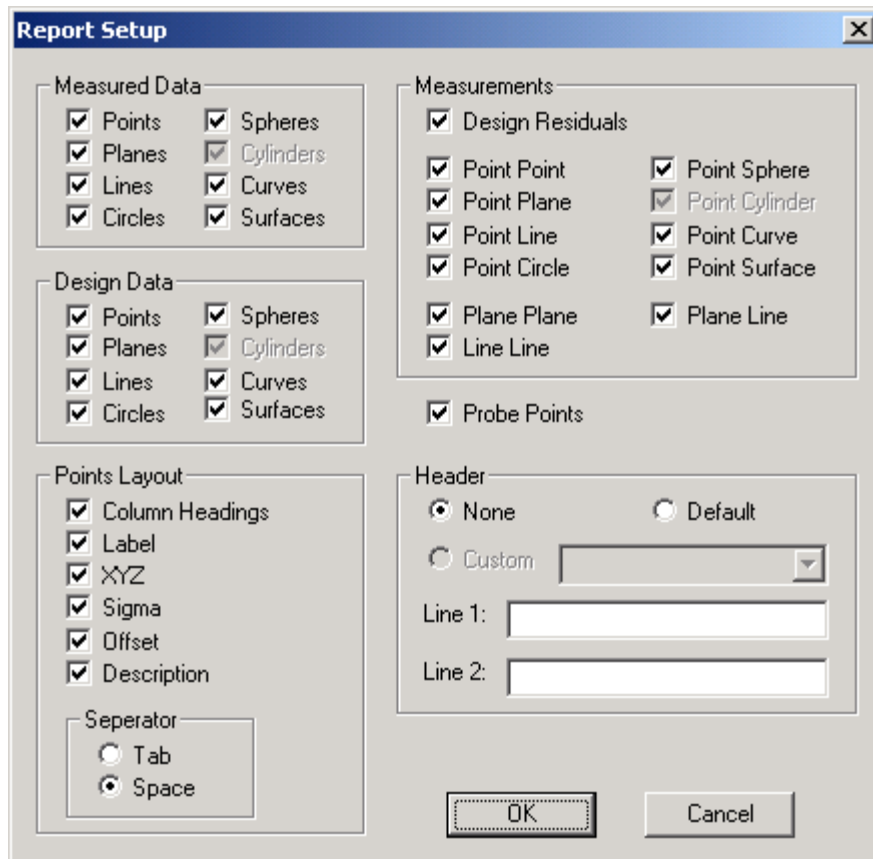

Print

The **Print** command can be used to print image frames or the 3D graphical view. Select the item that needs to be printed and set the graphic to the view that is to be printed. Select the **Print** command. Select the printer and press the **OK** command.

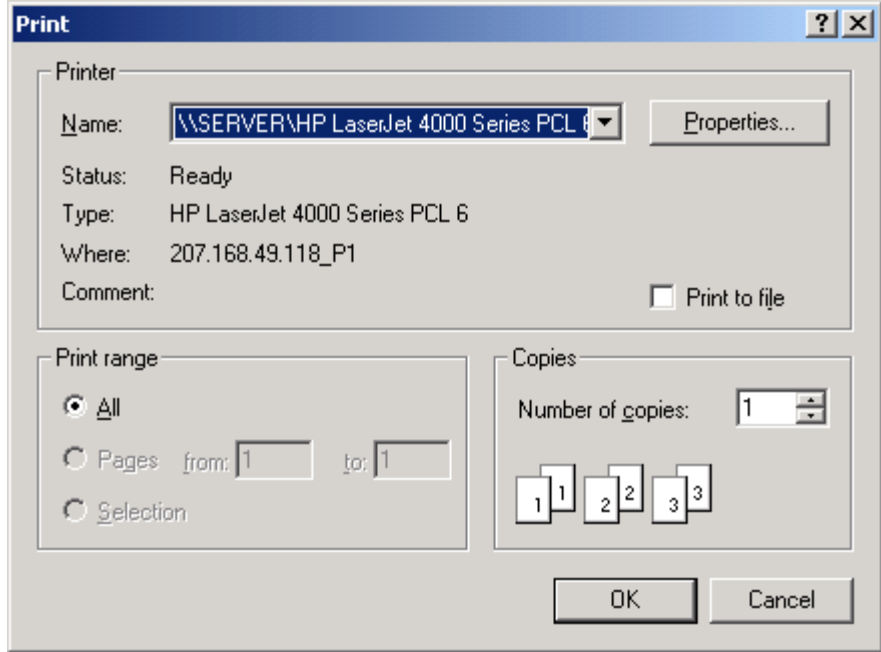

 To reverse the background on the print, open the **View Setup** dialog and select the **Display Colors** tab. Check the **Invert Pt/Bkg on Print**.

Print Preview

The **Print Preview** command is used to preview the data that will be printed.

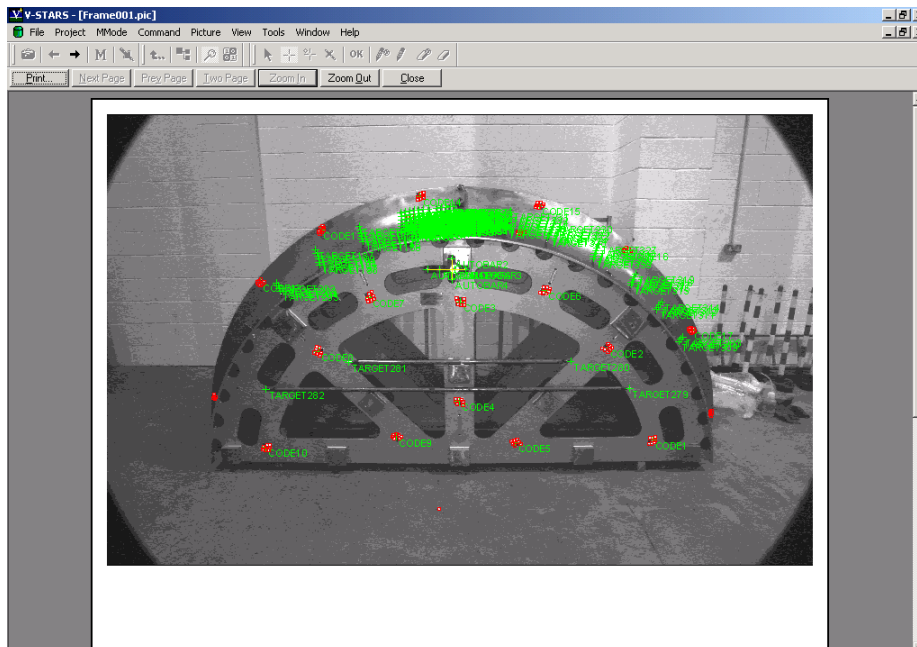

Print Setup

The **Print Setup** command is used to modify the current printer settings. The **Print** command can also be accessed from this dialog.

Recent Projects

A recent project can be loaded by simply selecting it from the recent project list at the bottom of the **File** menu.

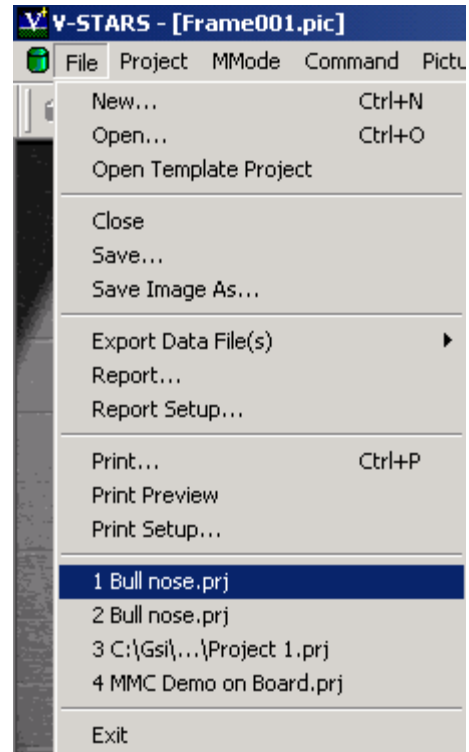

Exit

The **Exit** command closes the active project and then exits V-STARS.

Project Menu

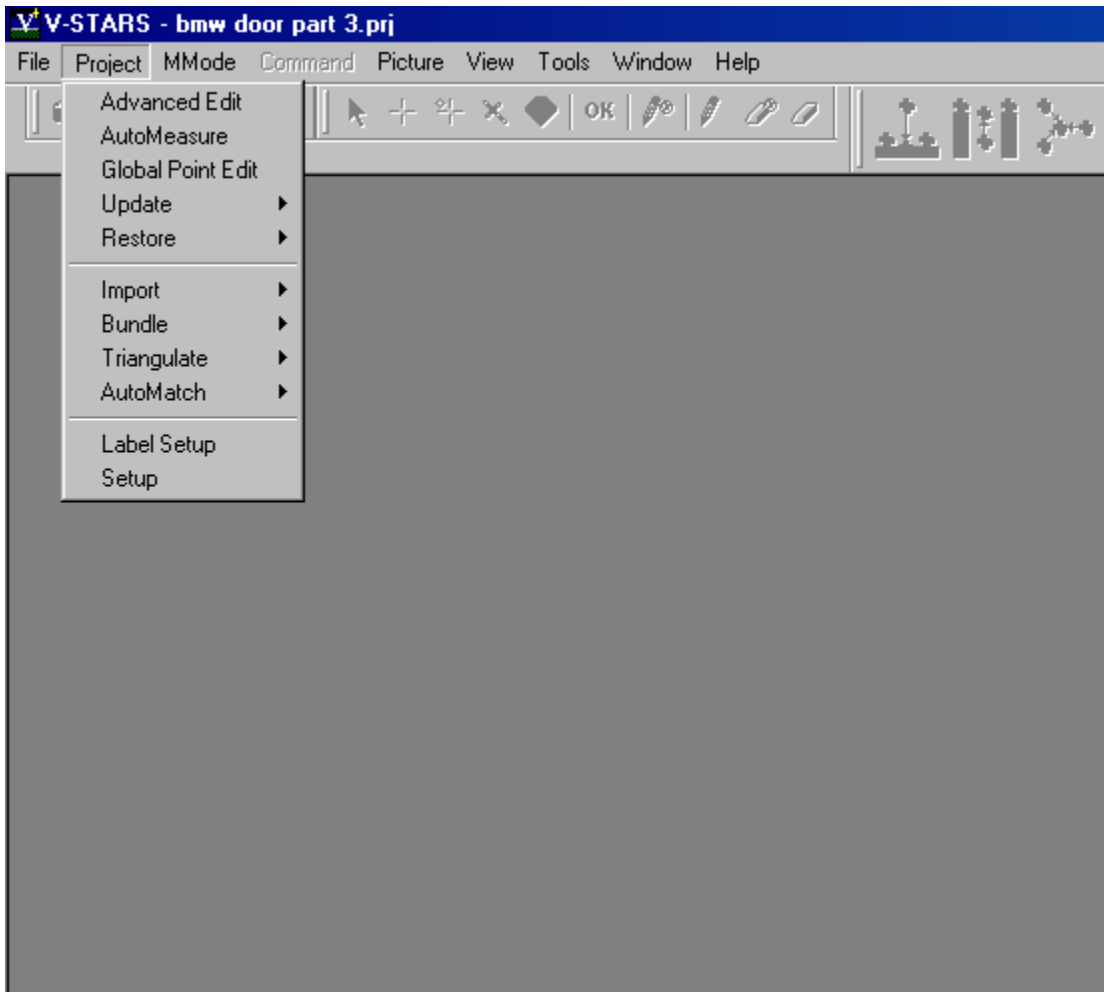

Advanced Edit

The **Advanced Edit** command opens the **Advanced Edit** dialog shown. From this dialog a number of different V-STARs, project settings can be altered. Driver files can be imported, and Scale Bars can be added or removed.

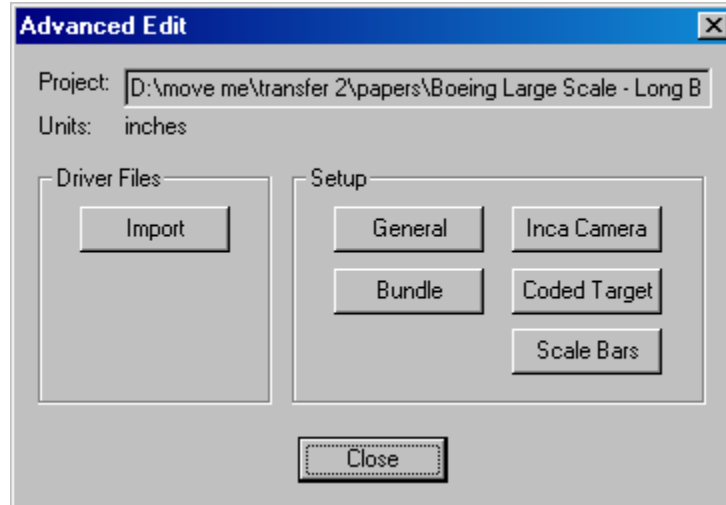

Import

The **Import** command opens the following dialog.

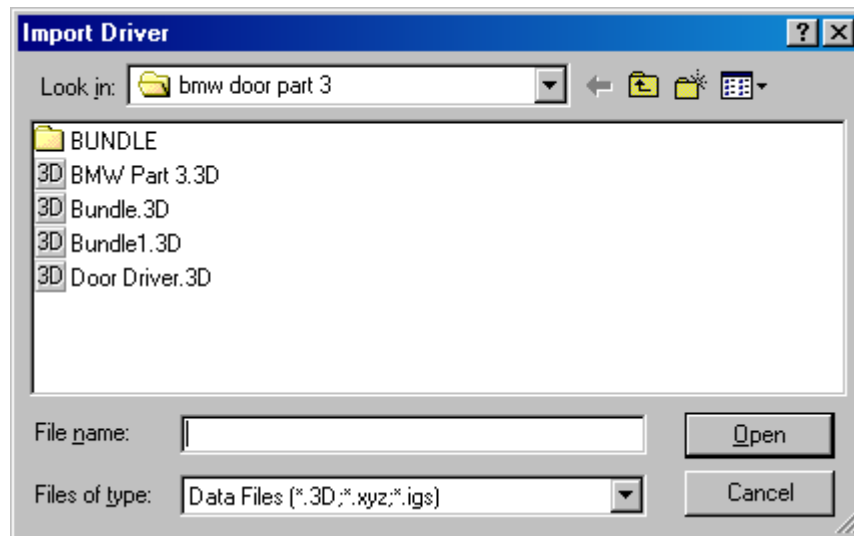

Select a 3D, XYZ or IGES file to import it into the project and set it as the current driver. If this file is in the "XYZ" format V-STARs will prompt you for the files units. A summary of the imported points is shown and the file is added to the project.

General Parameters

The **General** command opens the following **General Parameters** dialog. There are five option tabs.

General - Camera

Exposure - When a camera is online the camera exposure can be set from the camera dialog.

Strobe - If the camera is online and a Remote Camera Strobe (RCS) is in use, the strobe power can be set.

Save Images - In online mode images can be saved if the Save Images box is checked.

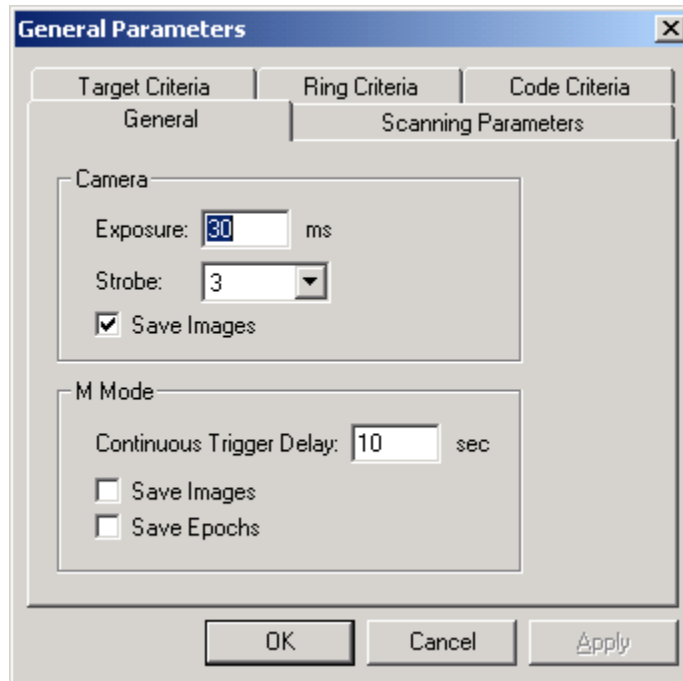

General - M Mode

Continuous Trigger Delay - Length of time between triggers when cameras are in continuous mode.

Save Images - Option to save images when in M-Mode.

Save Epochs - Option to save Epochs when in M-Mode.

Scanning Parameters – S-Mode

Delta – Indicates the value the pixel has to change for that pixel to be marked as the part of a target boundary.

Step – Number of pixels to scan.

White Level Bias – The Bias value is added to the blob's gain value and the resultant number is the background value for the target.

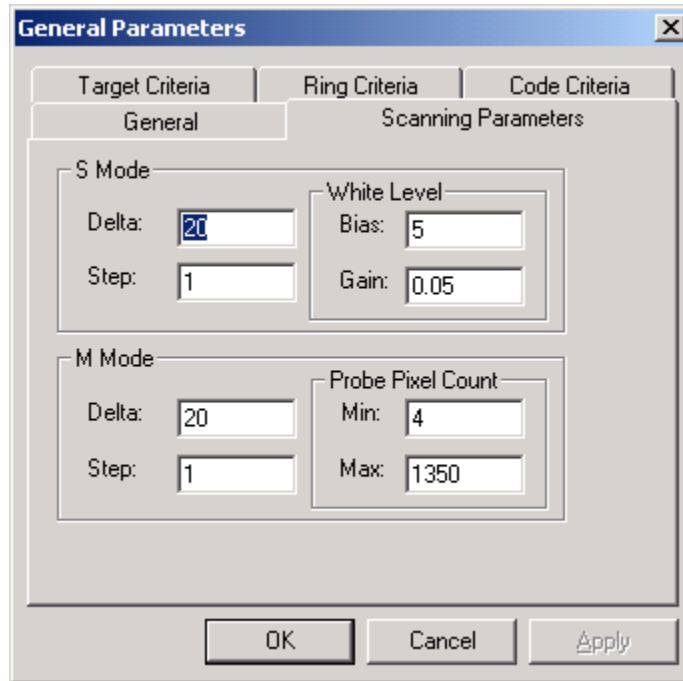

White Level Gain – The maximum and minimum values in the target blob are subtracted and multiplied by the gain.

Scanning Parameters – M-Mode

Delta – Indicates the value the pixel has to change for that pixel to be marked as the part of a target boundary.

Step – Number of pixels to scan.

Probe Pixel Count Min – Minimum number of pixels needed for a probe target to be valid.

Probe Pixel Count Max – Maximum number of pixels needed for a probe target to be valid.

Target Criteria

Target pixel count – minimum and maximum number of pixels to constitute a target.

X pixel count – minimum and maximum number of pixels in the X direction.

Y pixel count – minimum and maximum number of pixels in the Y direction.

The image shows a screenshot of a software dialog box titled "General Parameters". It has a tabbed interface with "General" and "Scanning Parameters" tabs. The "General" tab is active, and within it, the "Target Criteria" sub-tab is selected. The dialog contains several input fields for numerical values and a section for checkboxes. The values are as follows:

	minimum	maximum
Target pixel count:	7	300
X pixel count:	3	20
Y pixel count:	3	20
Black/White ratio:	0.49	1
Aspect ratio:	0.3	

Below the input fields is a section titled "Target Filters" containing two checked checkboxes: "Shape" and "Brightness". At the bottom of the dialog are three buttons: "OK", "Cancel", and "Apply".

Black/White ratio – The maximum and minimum ratio of black pixels to white pixels in a target blob.

Aspect ratio – Ratio of X pixels to Y pixels.

Target Filters – The target filters are very effective in removing false targets. This, in turn makes AutoMatching faster and more reliable. In some cases, they will remove legitimate targets. If so, this is generally because those targets are of poor quality and will be rejected in the Bundle adjustment anyway. One filter removes targets whose shape is unacceptable (Shape Filter); the other filters out targets that are too dim (Brightness Filter).

Ring Criteria

Target pixel count - minimum and maximum number of pixels to constitute a ring target.

X pixel count - minimum and maximum number of pixels in the X direction.

Y pixel count - minimum and maximum number of pixels in the Y direction.

The image shows a screenshot of a software dialog box titled "General Parameters". It has a tabbed interface with three tabs: "General", "Scanning Parameters", and "Code Criteria". The "Scanning Parameters" tab is active, and within it, the "Ring Criteria" sub-tab is selected. The dialog contains several input fields for configuring ring detection parameters. The "Target pixel count" field has a minimum value of 50 and a maximum of 6000. The "X pixel count" field has a minimum of 9 and a maximum of 90. The "Y pixel count" field also has a minimum of 9 and a maximum of 90. The "Black/white ratio" field has a minimum of 0.36 and a maximum of 0.9. The "Aspect ratio" field is set to 0.3. At the bottom of the dialog are three buttons: "OK", "Cancel", and "Apply".

	minimum	maximum
Target pixel count:	50	6000
X pixel count:	9	90
Y pixel count:	9	90
Black/white ratio:	0.36	0.9
Aspect ratio:	0.3	

Black/White ratio – The maximum and minimum ratio of black pixels to white pixels in a ring blob.

Aspect ratio - Ratio of X pixels to Y pixels.

Code Criteria

Target pixel count – minimum and maximum number of pixels to constitute coded target nuggets and the main pay point.

X pixel count – minimum and maximum number of pixels in the X direction.

Y pixel count – minimum and maximum number of pixels in the Y direction.

General		Scanning Parameters	
Target Criteria	Ring Criteria	Code Criteria	
	minimum	maximum	
Target pixel count:	5	300	
X pixel count:	2	20	
Y pixel count:	2	20	
Black./white ratio:	0.49	1	
Aspect ratio:	0.3		

Black/White ratio – The maximum and minimum ratio of black pixels to white pixels in a target blob.

Aspect ratio – Ratio of X pixels to Y pixels.

Bundle

The **Bundle** command opens the **Bundle Setup** dialog. The dialog is shown below. Refer to the [Bundle Setup](#) in the Bundle section of the manual for an explanation of the **Bundle Setup**.

INCA Camera

The **INCA Camera** command opens the following dialog. If the INCA cameras are online then the network connection can be reset or the image compression changed. If multiple cameras are in use there will be tabs visible.

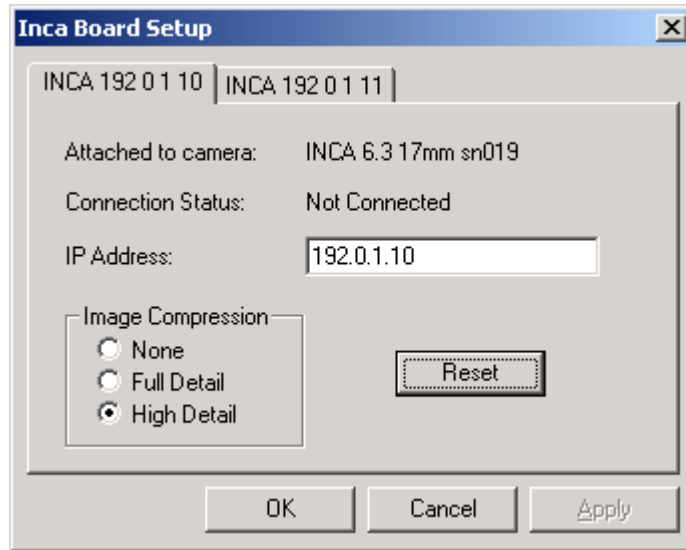

Coded Target

The **Coded Target** command opens the following coded target setup dialog. This is shown below.

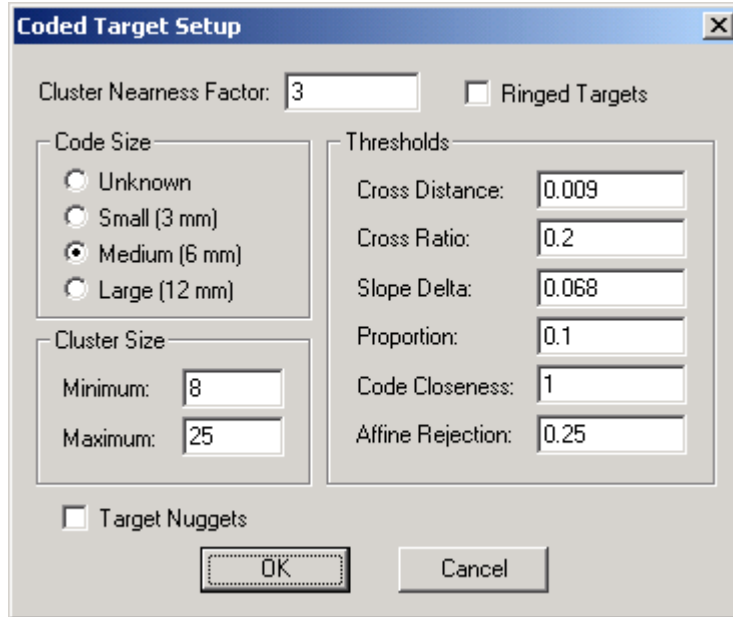

The screenshot shows a dialog box titled "Coded Target Setup" with a close button (X) in the top right corner. The dialog is organized into several sections:

- Cluster Nearness Factor:** A text input field containing the value "3".
- Ringed Targets:** An unchecked checkbox.
- Code Size:** A group box containing four radio button options: "Unknown", "Small (3 mm)", "Medium (6 mm)" (which is selected), and "Large (12 mm)".
- Cluster Size:** A group box containing two text input fields: "Minimum:" with the value "8" and "Maximum:" with the value "25".
- Thresholds:** A group box containing six text input fields: "Cross Distance:" (0.009), "Cross Ratio:" (0.2), "Slope Delta:" (0.068), "Proportion:" (0.1), "Code Closeness:" (1), and "Affine Rejection:" (0.25).
- Target Nuggets:** An unchecked checkbox.
- Buttons:** "OK" and "Cancel" buttons at the bottom.

- Cluster Nearness Factor** Minimum separation factor between adjacent nuggets.
- Ringed Targets** This box is checked if ringed coded targets are being used.
- Code Size** Specify the size of the coded targets being used. If mixed code sizes are being used, select the **Unknown** option.
- Cluster Size** The minimum and maximum number of target to cluster together before starting a new cluster.
- Thresholds** These parameters are used to set up the decoding process. These should not be adjusted without first consulting GSI.

Target Nuggets Check this box to switch on the coded nuggets. The square targets in a coded target (called the “nuggets”) can be measured just like the central target. This means that every time a code is seen, eight targets are measured. (Seven nuggets and one central point.)

This is very useful when a picture cannot be automatically measured because it has less than four known coded targets. By turning coded nuggets on, you can often automatically measure a picture that has only three (and sometimes only two) coded targets. This capability also supports a new kind of target developed by GSI that can greatly automate the measurement of certain geometrical features.

 The images must be scanned/re-scanned in order for the nuggets to be measured.

Scale Bars

The **Scale Bars** command opens the following **Add Scale Bar** dialog. This is shown below.

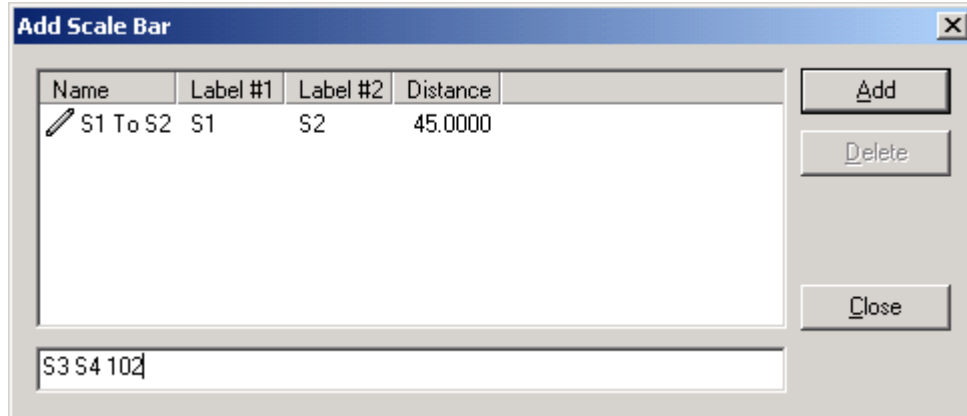

The dialog lists any of the scale bars in the current project. It is also possible to add a new scale bar by typing in the input box at the bottom of the dialog. The input format is as follows:

Label1 Label2 Distance

Press the **Add** command to add the scale bar to the project. To delete a scale bar, highlight it and press the **Delete** command.

AutoMeasure

Refer to the [AutoMeasure](#) section in the manual for more information on AutoMeasuring.

Global Point Edit

The **Global Point Edit** command opens the following dialog.

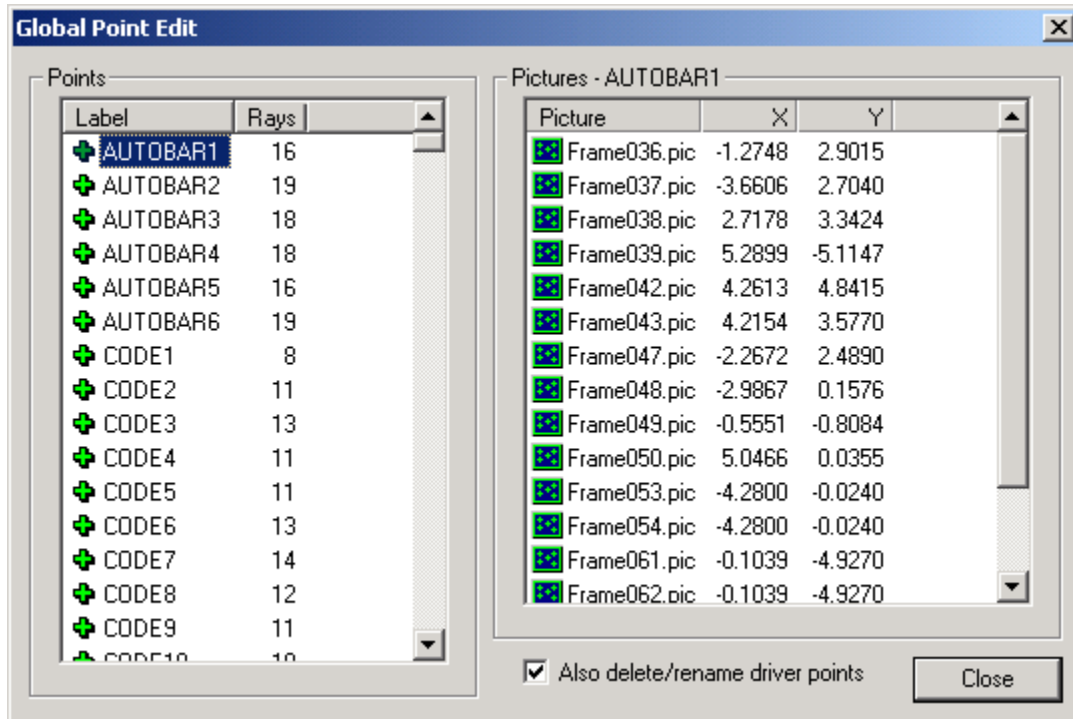

From this dialog, points or observations to points can be removed from the Bundle. When a point is deleted, it is removed from each of the images that have an observation to that point. Before deleting the points, you will be given an option to continue with the deletion.

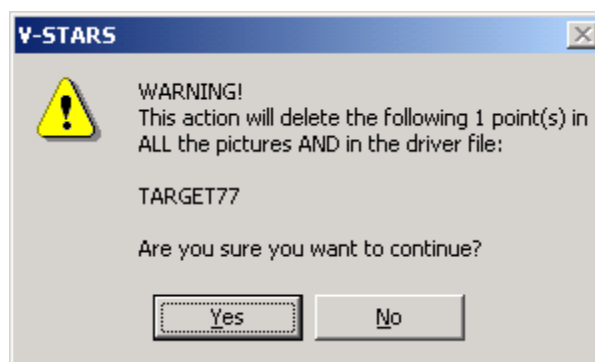

Points can also be renamed from within this dialog by highlighting the label and changing the text.

Update

The **Update** command has several options. These are shown below:

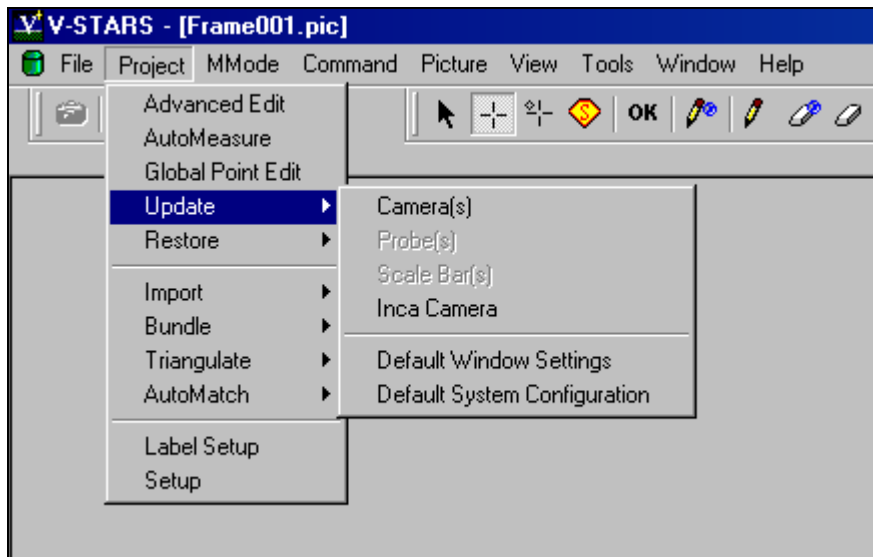

Camera(s) The update command will copy the camera parameters in the current project to the camera in the `c:\GSI\System` directory. If the camera does not exist in the System folder, you have the option to copy it there. An update is tantamount to a camera re-calibration and should not be completed unless the network used to re-calibrate the camera was an especially strong one. The update command is password protected to prevent accidental implementation.

Probes The update command will copy the probe parameters in the current project to the corresponding probes in the `c:\GSI\System` directory. If the probes do not exist in the System folder, you have the option to copy them there. An update is tantamount to a probe re-calibration and should not be completed unless the correct calibration procedure has been followed. The update command is password protected to prevent accidental implementation.

Scale Bars The update command will copy the scale bar parameters from the current project to the scale bar in the `c:\GSI\System` directory. If the scale does not exist in the System folder, you have the option to copy it there. An update is tantamount to a scale bar re-calibration. The update command is password protected to prevent accidental update.

INCA Camera This is used to update the INCA camera calibration files for any camera in the project. The camera calibration file on the INCA camera is overwritten with the one in the project. The update procedure is written to a PCMCIA disk. When this disk is inserted into the INCA camera the update is completed automatically when the camera boots. You will be prompted for the system password prior to the update procedure being written to the PCMCIA disk.

WARNING – If you own multiple cameras take care not to update the incorrect camera. If you happen to update the camera with the incorrect camera file, then simply repeat the update process with the correct file.

Default Window Settings This updates any of the Window settings that you have set. The position of toolbars, windows and other Window settings is saved. New projects take on these settings.

Default System Configuration This updates any of the V-STARS system settings that you have set. Any changes that have been made are saved in the default GSI32.ini file. Any new projects take on these settings.

Restore

The **Restore** command is used to restore any settings that have been made to the Windows Settings or System Configuration back to the factory default.

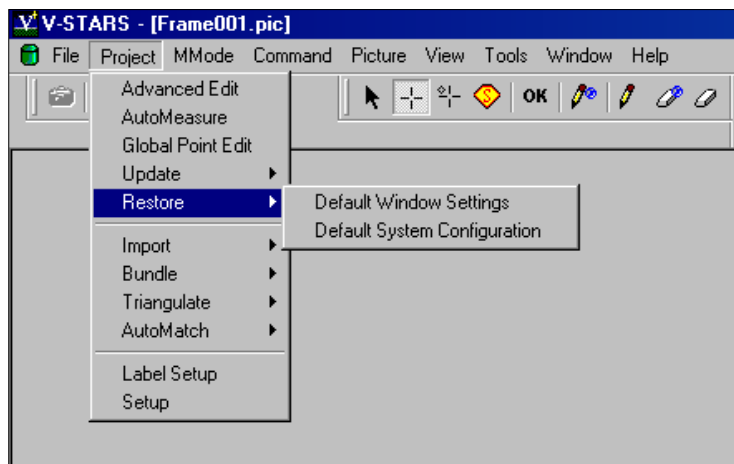

Import

The **Import** command has several options. These are shown below:

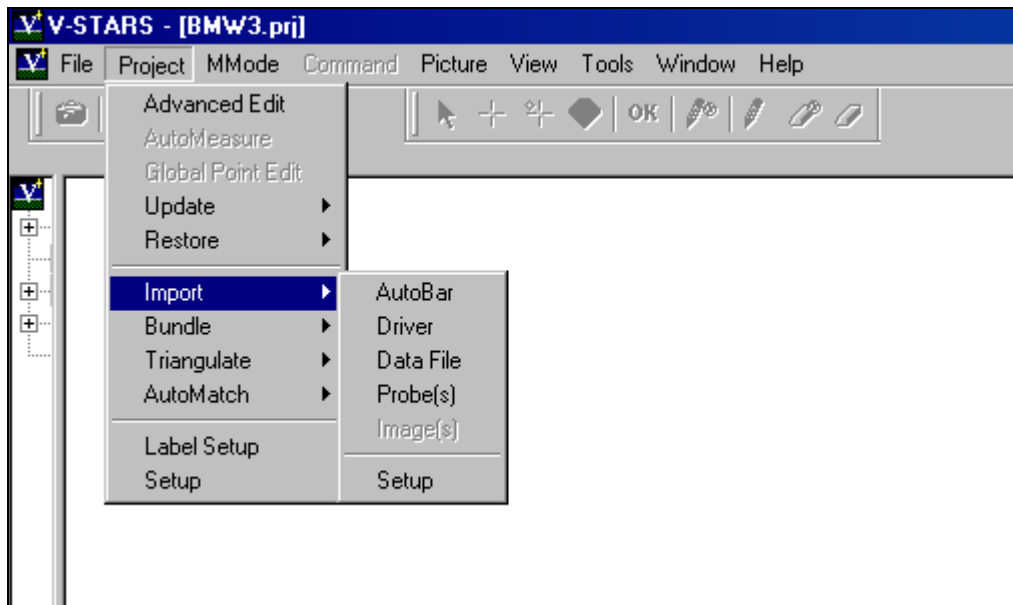

AutoBar

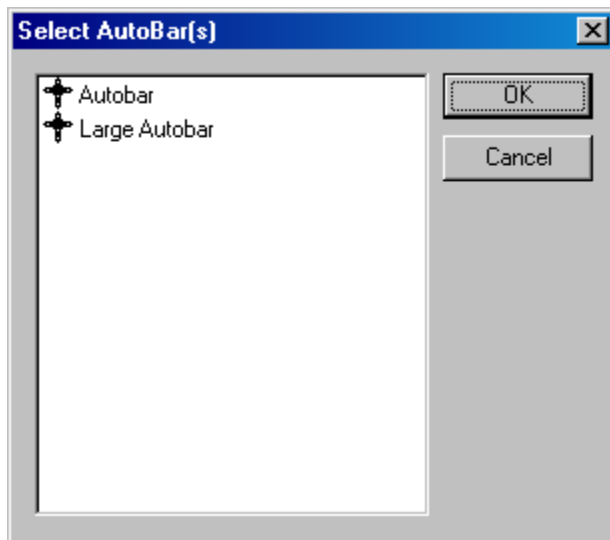

Add an AutoBar to the project. This is very useful if you own multiple AutoBars. Once imported, the AutoBar is set as the Driver file. The AutoBars that V-STARS lists are found in the C:\GSI\System directory.

Typically, the AutoBar is imported automatically for you at the start of the AutoMeasure routine and hence this function is rarely used.

Driver



This is used to import any 3D, XYZ or IGES file and mark it as the Driver for the project. Navigate to the desired file, select it and press the Open button. If this file is in the "XYZ" format V-STARS will prompt you for the files units. A summary of the imported points is shown and the file is added to the project.

For more information, refer to the Importing Driver Files section of the manual.

Data File

This is used to import any 3D, XYZ or IGES file into the project. Navigate to the desired file, select it and press the Open button. If this file is in the "XYZ" format V-STARS will prompt you for the files units. A summary of the imported points is shown and the file is added to the project.

For more information, refer to the Importing Data Files section of the manual.

Probes

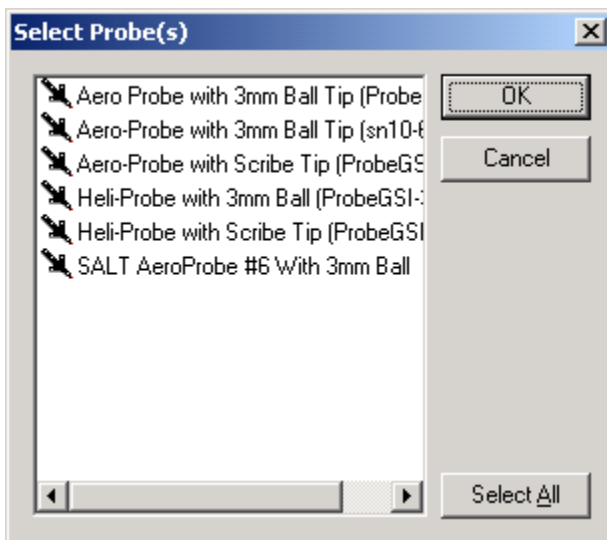

This is used to import Probes into the project. By default, the probes are selected from the GSI system directory.

Images

This is used to copy the project images into the project. You are given a warning before import being completed as the image copy can take a few minutes depending on the number of images in the JOB.

For more information, refer to the [Import Images](#) section of the manual.

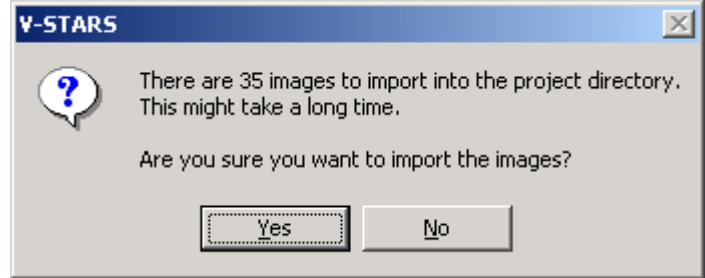

Setup

This dialog allows you to define the manner in which IGES files are imported.

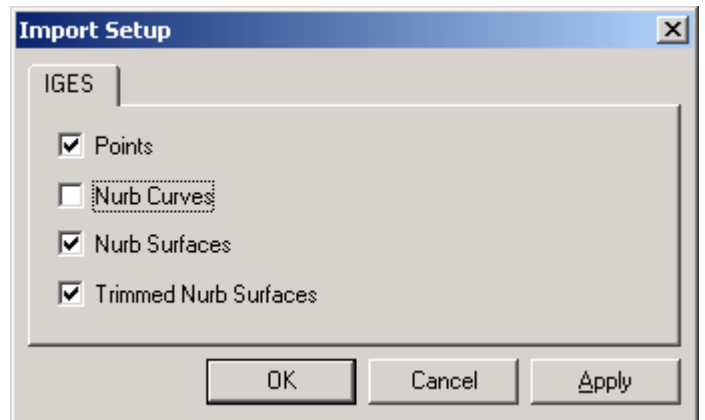

Bundle

Refer to the [Bundle](#) section for more information on the Bundle menu.

The **Bundle** command has three options. These are shown below:

Run When Run is selected the main Bundle dialog will be opened.

The Run command is dimmed if there are no images scanned or frames resected. It is also dimmed if there are not at least two frames resected.

Summary When Summary is selected, the Bundle Summary dialog is opened. A typical summary is shown below.

The screenshot shows the 'Bundle Summary' dialog box with the following data:

Category	Sub-category	Value
Status	Status	[Empty]
	Rejection Limit	0.80
Current Point	Current Point	[Empty]
	Residual RMS	[Empty]
Pictures	Total	35
	Weak	0
	Bad	0
Points	Total	379
	Weak	4
	Bad	0
	Two Ray	0
Scales [millimeters]	Total	0
	Weak	0
	Bad	0
	RMS	N/A
Cameras	More...	[Button]
Control Points	N/A	[Text]
Control Points	More...	[Button]
Initial Bundle	<input type="checkbox"/>	[Checkbox]
Accuracy [millimeters]	RMS: X	0.009
	Y	0.009
Accuracy [millimeters]	Z	0.009
	Max: X	0.020
Accuracy [millimeters]	Y	0.018
	Z	0.021
Accuracy [millimeters]	More...	[Button]
Points over limit	0	[Text]
Plan Quality Factor	1.13	[Text]
RMS of Measurements	0.20um	[Text]
Buttons	Setup	[Button]
	Save Info	[Button]
	Close	[Button]

Setup When Setup is selected, the Bundle Setup dialog is selected. Refer to Bundle Setup section for more information.

Triangulate

The **Triangulate** command has several options. These are shown below:

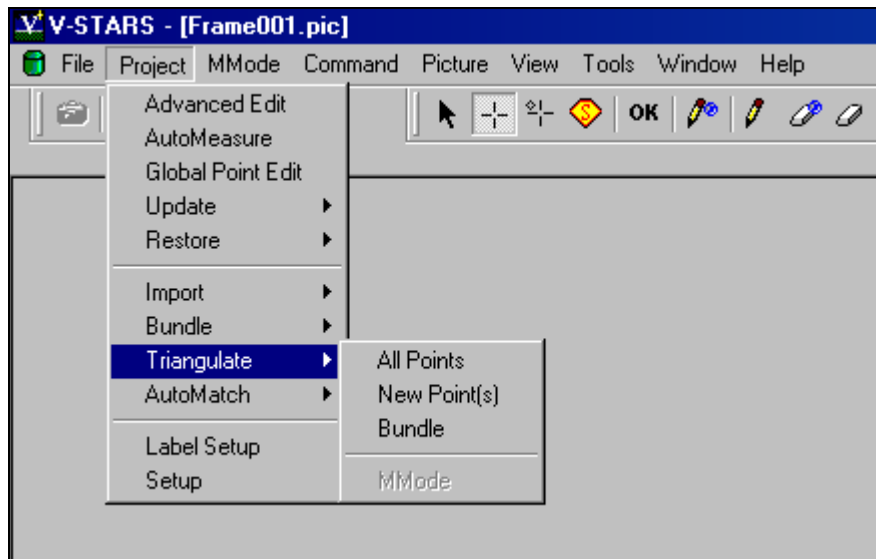

All Points

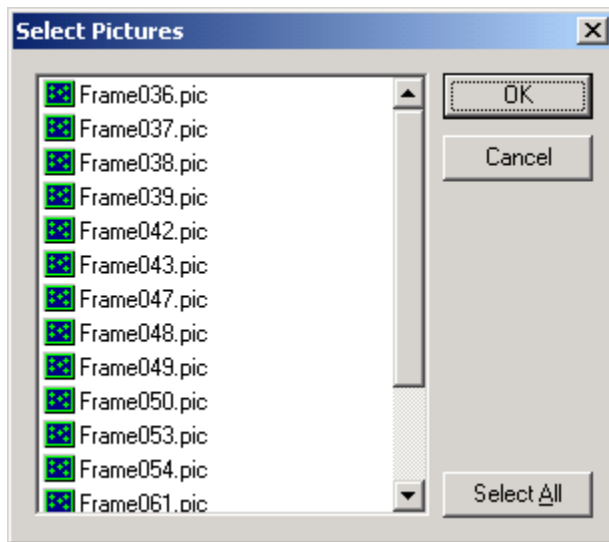

Select the **All Points** function to triangulate new points in particular pictures. At least two pictures must be selected. A **Triangulation Summary** dialog appears and you are given the option to accept or reject the Triangulation and to name the triangulation file.

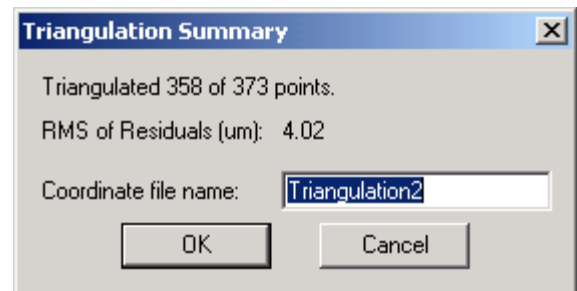

New Point(s)

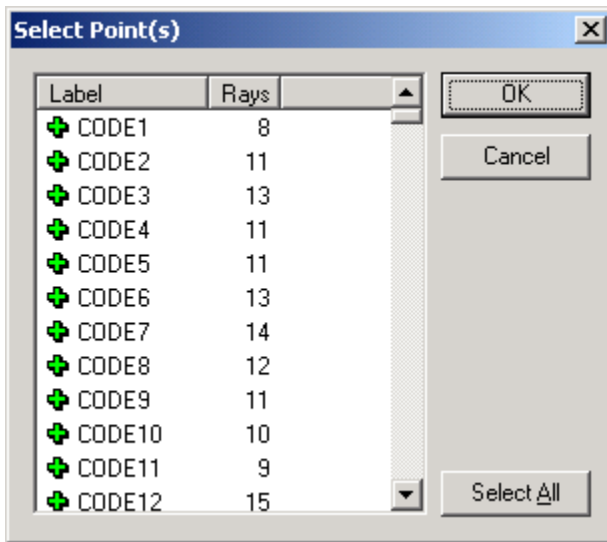

Select the New Points function to triangulate selected new points. The number of rays to each new point is displayed to guide you.

Once again, a triangulation summary appears before the Triangulation file being created.

Bundle

Run a bundle with the camera locations and camera calibration parameters held fixed. This provides you with improved triangulated values.

MMode

In M-Mode Triangulate any of the points seen in both images.

AutoMatch

The **AutoMatch** command has three options. These are shown below.

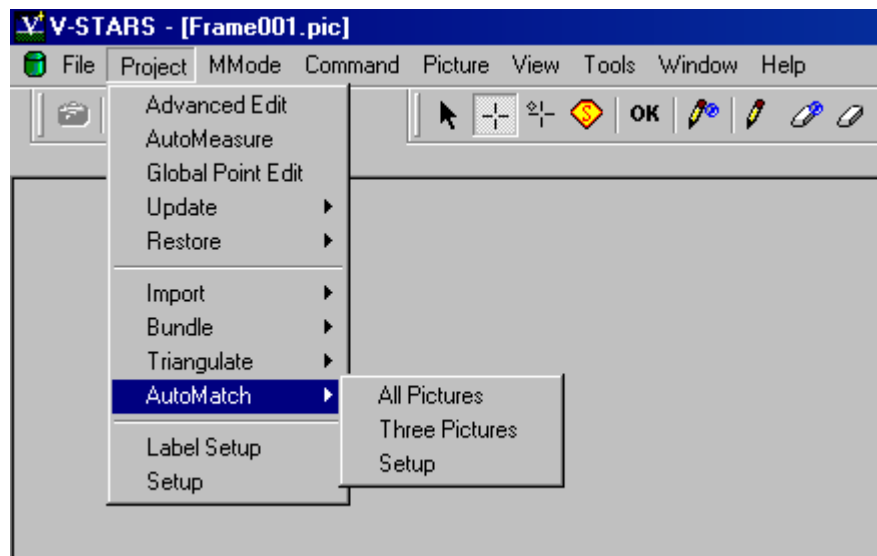

All Pictures

Select the **All Pictures** function to run the full AutoMatch procedure. In this case, all possible combinations of images will be calculated. The best combinations (typically 16) are then used to determine the location of any new points.

Three Pictures

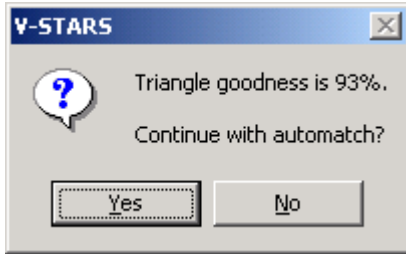

Select the Three Pictures option to select three images to AutoMatch. In this mode of AutoMatch it is up to you to decide whether the combination selected is worth AutoMatching. A Triangle goodness number is displayed to help this decision process. A figure of greater than 20% is recommended.

Setup

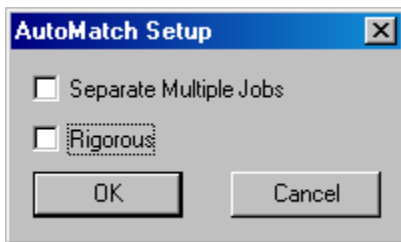

Separate Multiple Jobs – This option is designed for use with the V-STARS PRO-SPOT system. When checked, imported jobs will be AutoMatched separately.

Rigorous – Enable the rigorous AutoMatching routines. This mode is slower, but more thorough.

Label Setup

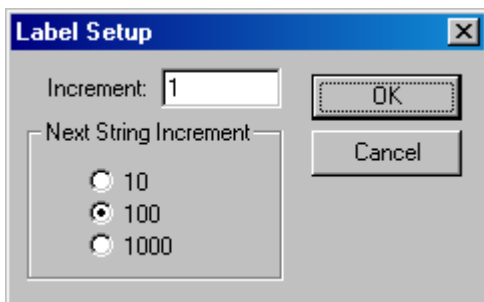

The **Label Setup** command loads the Label Setup dialog. This is shown in the adjacent image. This dialog sets the point and string increments. Based on the values in the dialog shown, the first string would start with 101. Subsequent points would be labeled 102, 103, and so forth. By setting the increment to a negative value the string will decrement.

Selecting the Next String command   from the **Command** menu will change the string to 201.

MMode Menu

Introduction

Please refer to the [M Mode manual](#) for an explanation of the Mmode Menu.

Command Menu

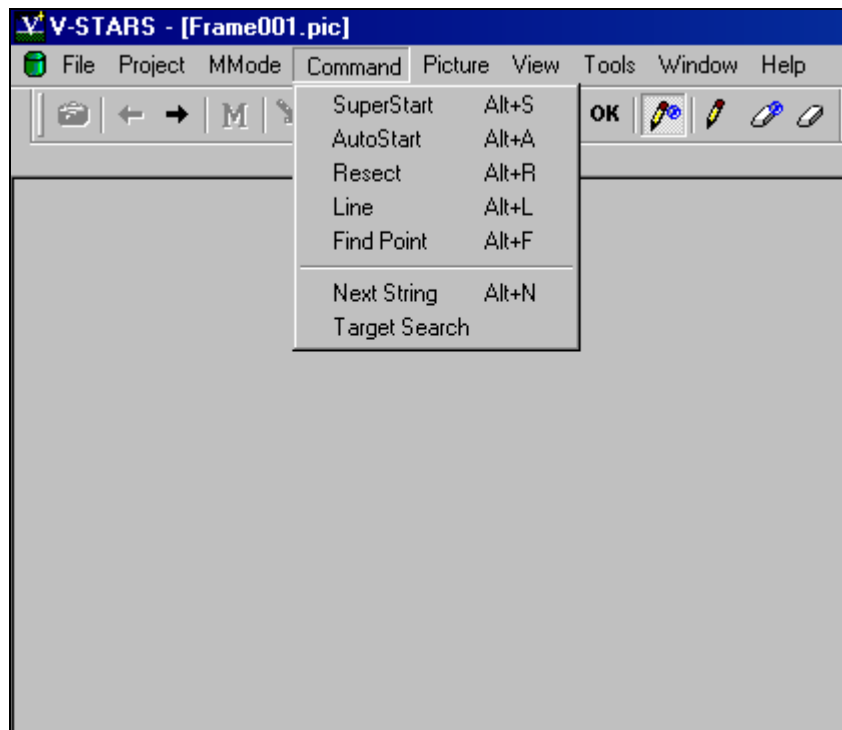

 The command menu is only active when an image is open.

SuperStart

The **SuperStart** command will reset the open picture and complete the following processes:

1. Scan image for potential targets.
2. Determine whether an AutoBar is present.
3. Decode any codes that are present.
4. Use the known (in XYZ) coded targets and AutoBar found to determine the location in space (resection) of the image.
5. Driveback to any points in the Driver file.

If the frame has been measured previously then you will be warned before the image is reset.

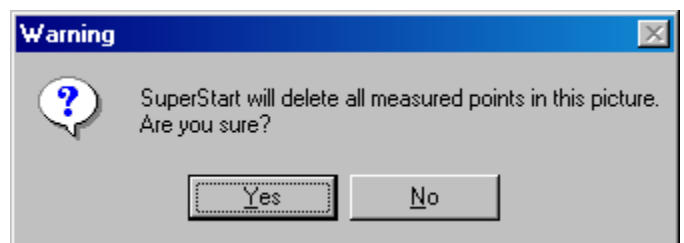

AutoStart

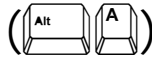

The **AutoStart** command will use the existing resection values to driveback to the points in the driver file. Any points already measured in that frame will be skipped.

Resect

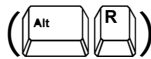

The **Resect** command will open the **Resect Picture** dialog.

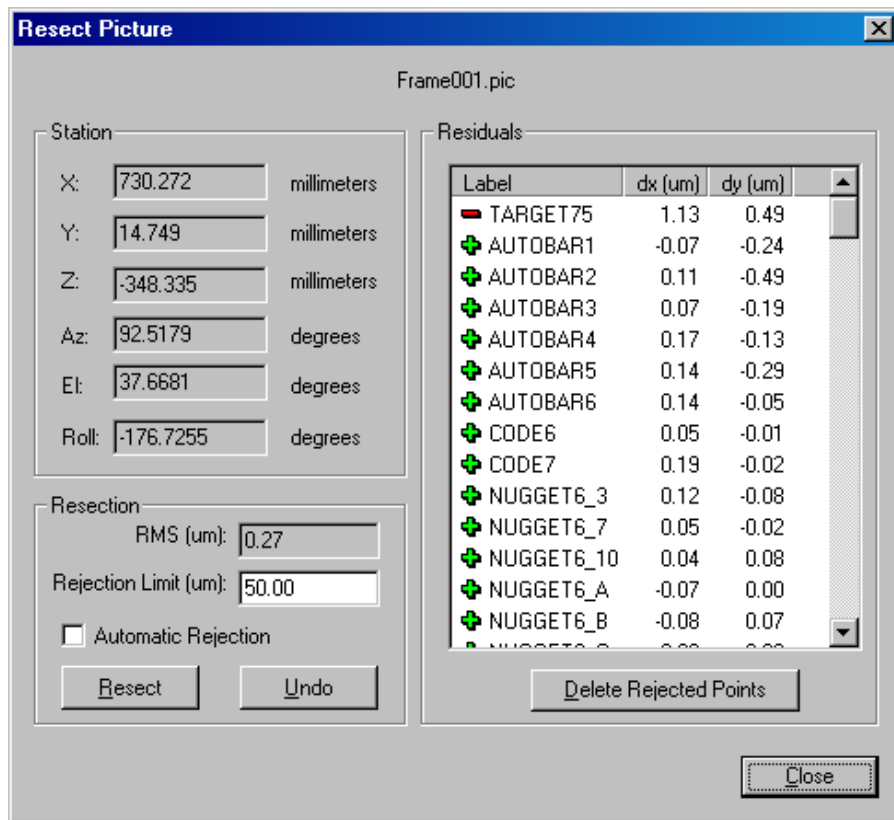

The dialog displays the position (XYZ) and attitude (Az, El, and Roll) of the camera in space.

The **Rejection Limit** can be adjusted and the resection re-run by using the **Resect** button. By selecting **Automatic Rejection**, the software determines the optimal rejection limit.

In the residuals frame all the rejected points can be removed by selecting the **Delete Rejected Points** command. Individual observations can also be enabled, disabled or deleted by right clicking over the points you wish to modify and selecting one of the options.

Label	dx (um)	dy (um)
TARGET75	1.13	0.49
AUTOBAR1	-0.07	-0.24
AUTOBAR2	0.11	0.49
AUTOBAR3		0.19
AUTOBAR4		0.13
AUTOBAR5		0.29
AUTOBAR6		0.05
CODE6	0.05	-0.01
CODE7	0.19	-0.02
NUGGET6_3	0.12	-0.08
NUGGET6_7	0.05	-0.02
NUGGET6_10	0.04	0.08
NUGGET6_1	0.07	0.08

Line

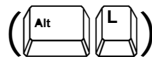

The **Line** command will automatically label points located in a uniform direction that have approximately equal spacing. The first and second points that have been labeled determine the direction of the line. For example, it is possible to label a circle as the direction is continuously updated. The routine will stop when the start of the circle is reached.

The line function is typically used to label new points or for Global re-labeling. In both cases, the function behaves the same.

The software will beep when it reached a gap in the line or the last point in the sequence.

Find

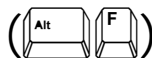

The **Find** command will find a point that you have defined. If the point is visible and measured in a frame, the cursor will move to its location.

Next String



The **Next String** command will increment the current label by the amount specified in the String Setup dialog. Refer to [Label Setup](#) for more information.

Target Search

The **Target Search** command will scan the image and locate any potential targets. This option is typically used when you have changed one of the scanning parameters and you want to see the effects of the change.

Picture Menu

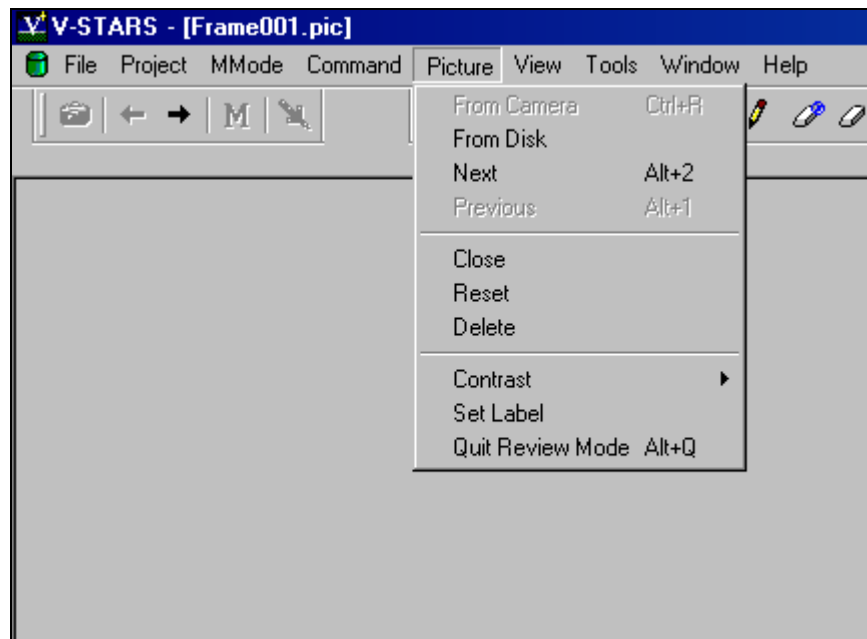

From Camera

The **From Camera** command will only be active if an INCA camera is in online mode. When selected the default camera will capture an image. This command is equivalent to the camera icon.

From Disk

The **From Disk** command will load a dialog that can be used to navigate to an image path. The dialog is shown below:

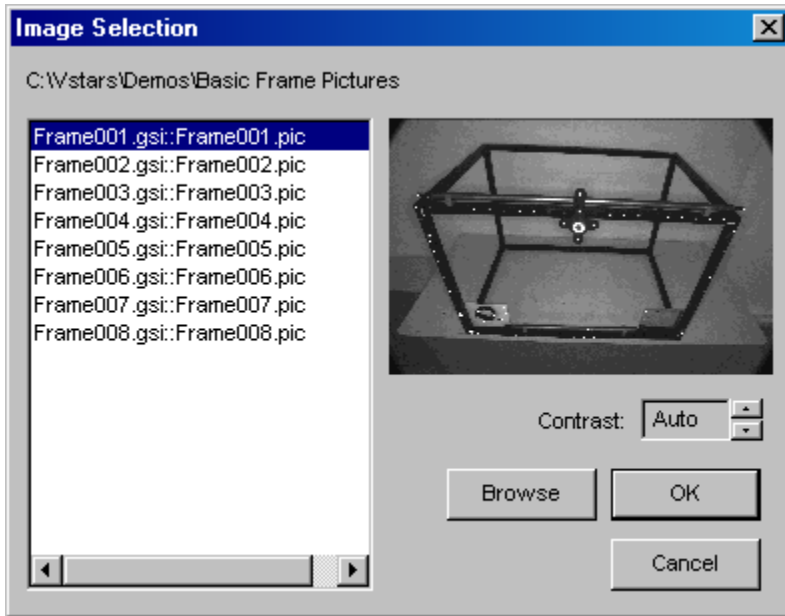

Press **Browse** to select the path that the images can be found in. When a folder with GSI images has been located, a thumbnail of the selected file will be displayed. Adjust the Contrast controls to adjust the image contrast.

This command is also very useful to view different Jobs and carry out Job housekeeping.

Next

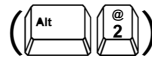

The **Next** command will open the next image in the project. If there is no next image, the command will be ignored.

Previous

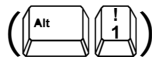

The **Previous** command will open the previous image in the project. If there is no previous image, the command will be ignored.

Close

The **Close** command will close the image that is currently open and active.

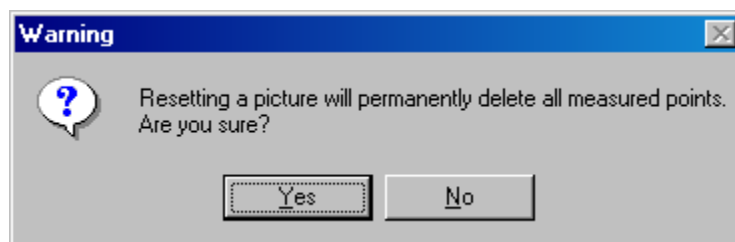

Reset

The **Reset** command will reset the active image. Prior to doing this, you will be warned.



Delete

The **Delete** command will delete the active image picture file from the project.

 The  key does not remove the original image from the disk, it only removes the file that represents that image in the project.

Contrast

The **Contrast** command will adjust the contrast setting of the active picture. The settings range from 0 (No enhancement) to 10 (Maximum enhancement). The AUTO setting is used to get the best contrast solution.

Right clicking on the image and selecting **Contrast** can produce the same result.

Set Label

The **Set Label** command will sets the current point label. This command can be simply reached by starting to type the label name whilst in the active window.

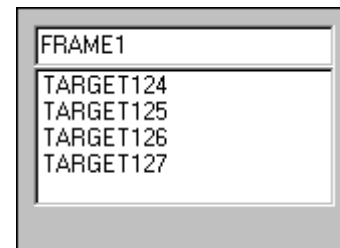

Quit Review Mode



After an AutoStart or SuperStart, points that have not be found, but are coordinated, will appear in red. To remove these annotations simply select the **Quit Review** command.

View Menu

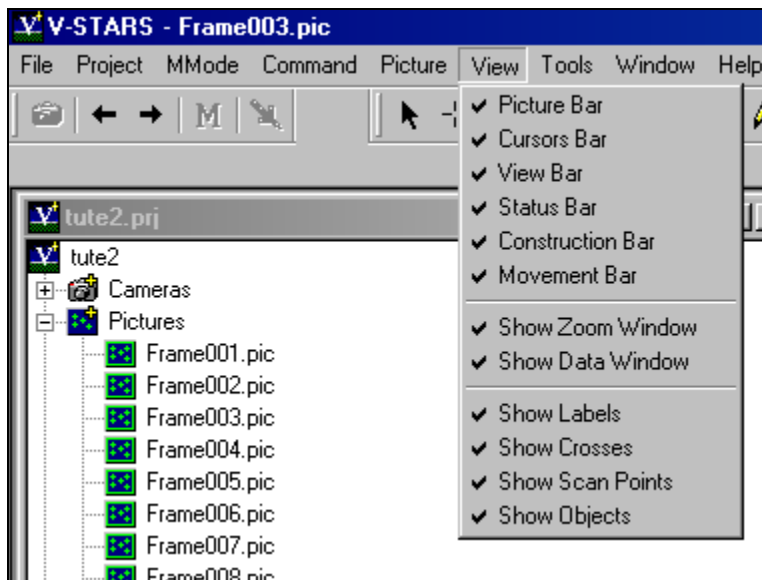



Picture Bar





The Picture Bar features five icons. These have the following functionality.

 **Camera Icon** – Take a picture. Only active if one or more cameras are online. This command can also be initiated from the **Picture – From Camera** menu.

 **Previous Image** – Go back one image. When the first image is already active, the left arrow will be dimmed.

 **Next Image** – Go forward one image. When the last image is already active, the right arrow will be dimmed.

 **M Icon** – Initiate Multi-camera mode. Only active if two or more cameras are online

 **Probe Icon** – Trigger the cameras in Multi-camera mode to fire simultaneously. This icon is only active if two or more cameras are online, and in M Mode.

Cursors Bar





The Cursor Bar is made up of nine icons. These have the following functionality.

 **Selection Cursor** (F1) – This is the default cursor. This cursor must be active when you wish to do any point selection.

 **Cross Cursor** (F2) – Use this cursor is manually locate points in the image that are located in the driver file. If the label of a driver point is set the cursor will automatically change from the Selection Cursor to the Driver Points Cursor.

 **New Points Cursor** (F3) – Use this cursor is manually measure new points.

 **SuperFind Cursor** (F4) - This cursor allows new points to be measured in all images (in which they exist) by measuring them in a single image. The point is measured in the current picture and in any other pictures that see the point. The point is then automatically triangulated and added to the current driver file. Refer to the [SuperFind](#) section for a more complete description.

 **OK Cursor** – AKA "God Mode". This cursor is used in conjunction with the Driver and New point cursor. When activated many of the target criteria rules are disabled. This means that targets that fail the acceptance criteria can still be measured. **WARNING** – Including unacceptable targets in the measurement can produce inconsistent and inaccurate results.

 **Global Rename Cursor** – Use this cursor when you wish to rename points in the images or driver file. All observations to the point will be renamed with the new label. Note that points in the previous Bundles will NOT be renamed.

 **Rename Cursor** – Use this cursor when you wish to rename points only in the current image or 3D file.

 **Global Delete Cursor** – Use this cursor when you wish to delete points in the images or driver file. All observations to the point will be deleted. Note that points in the previous Bundles will NOT be deleted.



 **Delete Cursor** – Use this cursor when you wish to delete points only in the current image or 3D file.



View Bar





The View Bar is made up of four icons. These have the following functionality.

 **Up on level** – Press this icon to move one level up the directory tree.

 **Bring Project to Top**  – Press this icon to bring the V-STARS directory to the foreground.

 **Show/Hide Zoom Window**  – Press this icon to activate or deactivate the data zoom window. This icon is only active if a picture window is open.

 **Show/Hide Data Window**  – Press this icon to activate or deactivate the image data window. This icon is only active if a picture window is open.
Right click in the data window to view the additional options.

Pixel View – Display pixel grayscale values.

Target View – Display potential target pixels.

Size to Zoom – Resize Data window to match Zoom window.

Hide – Close Data window.

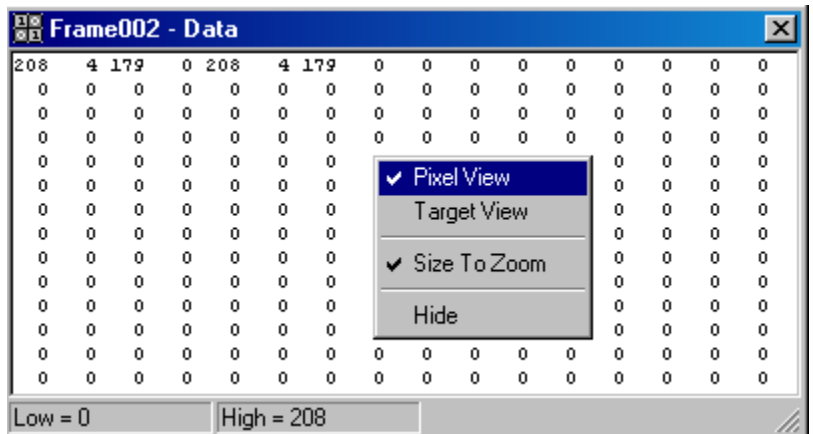

Status Bar



The Status Bar displays the status of V-STARS. If an image is open, the XY location of the cursor will also be displayed.

Construction Bar



The Construction Bar is made up of nine icons. The bar will only be active

when the cameras are in M-Mode. For a description of the functions of the icon, please refer to [M Mode Manual](#).

Movement Bar



The Movement Bar is used to control cameras connected to the Electronic Pan Head. The buttons will be disabled unless a camera is connected to the pan head.

Show Data Window

Switch on the data window. Please refer to the explanation given under the [View Bar](#) section.

Show Zoom Window

Switch on the zoom window. Please refer to the explanation given under the [View Bar](#) section.

Show Labels

Switch on the target labels in the picture window. The labels will be displayed in green.

Show Crosses

Switch on the crosses that identify targets. If crosses are switched off then the labels will also be removed. The crosses will be displayed in green.

Show Scan Points

Show points that have been identified as potential targets by V-STARS. Scan points are denoted by red squares.

Show Objects

Show the location of items such as Scale Bars and the AutoBar. A yellow line drawn between the endpoints denotes a scale bar. A yellow cross through the outer points identifies an AutoBar.

Tools Menu

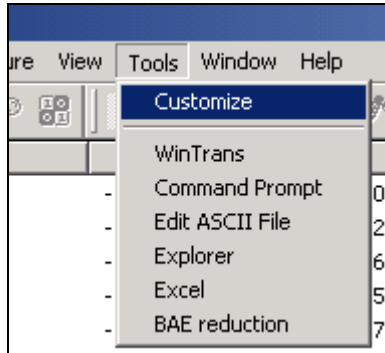

Customize

It is possible to add programs to the tools menu. This means that you can call programs such as Word, Excel or Explorer directly from V-STARS. To add a new tool:

1. Select the **Customize** option from the **Tools** Menu.
2. Press the **Add** button to add a new tool.
3. Browse to the appropriate executable using the "..." button.
4. Enter any relevant arguments.
5. Select the initial directory for any data using the "..." button. If you want the command to use the current project directory as the initial directory, leave this field blank.
6. Press **OK** to accept the tool.

This dialog shows how to create a tool that will open an explorer window to the current project. This is done by running explorer and parsing the arguments "/e,.".

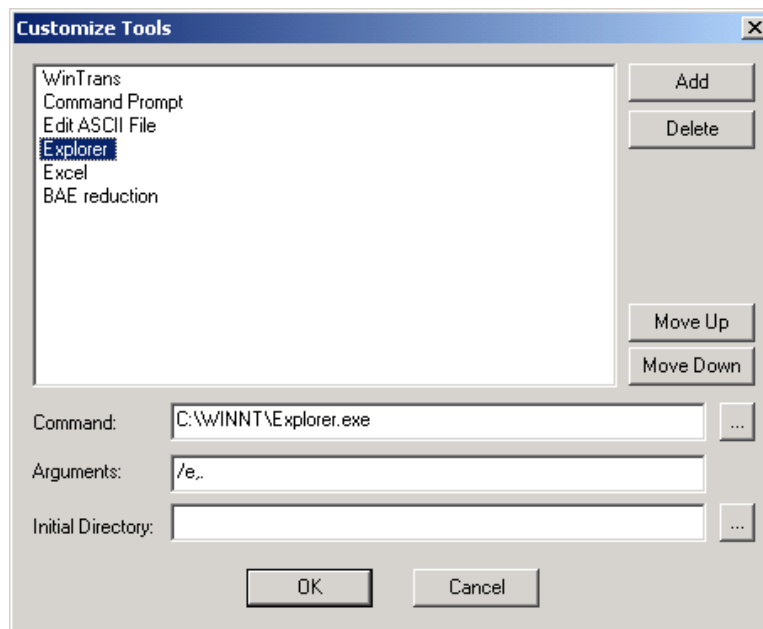

Zipping a Project

You can easily compress (zip) all project data using the Zip Projects commands on the Tools menu. This is accomplished using PKZIP. The compressed project is a .zip file that is given the name "*project name.zip*". You have two choices; you can save all data, or all data except the image files (*.gsi files). This feature is useful for saving a completed project in a compressed format that saves space. However, its main use is to allow you to easily zip up the state of a project when a problem or bug is found. Then, you can send the zip file to GSI for analysis. We urge customers to use this feature. Often, as you work around or through a problem, you end up changing the state of the project, and we can no longer reproduce the problem. It will help us tremendously in finding and diagnosing problems if you use this command immediately after finding a problem.

To save a project, select either **Zip Project – No Images** or **Zip Project – With Images** from the **Tools** menu. A DOS window will be displayed showing the progress of the ZIP operation. We recommend you not do anything else while the ZIP operation is running. When it is done, the DOS window will disappear, and the data you selected will be saved in a file in the project directory. The file's name will match the name of the project and will have the name "*project name.zip*".

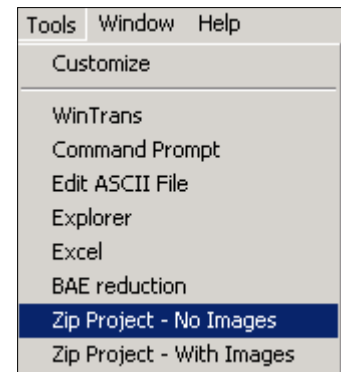

 The **Zip Project – With Images** command will only zip the .gsi files if they are in the project directory, or a subdirectory of the project directory. Use the [Import Images](#) command to copy the images into the project directory.

Right Click Menus

The following dialog boxes and menus can be accessed by "right-clicking" in certain areas within the V-STARS project. Right click menus are a very handy way to access some of the more commonly used V-STARS functions and commands.

Cameras Icon

Right click on the camera [icon](#) or on any camera in the camera tree.

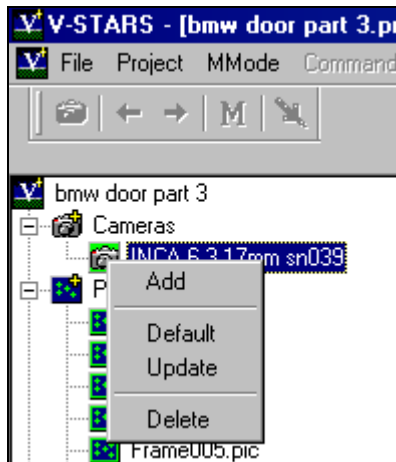

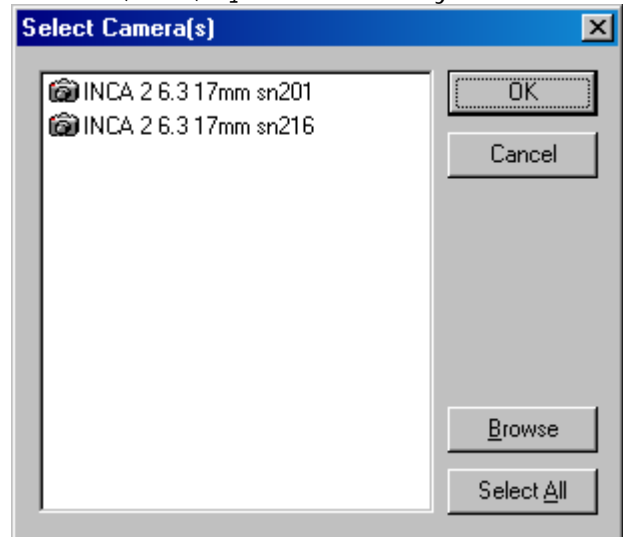

Default – Set the camera as the "active" or default camera. This is only applicable when there are more than two cameras in the project. The default camera will be the one that fires when the camera icon is pressed.

Add – Add a camera to the project. The following dialog is opened. You can select a camera or have the option to **Browse** for a camera. The cameras listed are located in the `C:/GSI/System` directory.

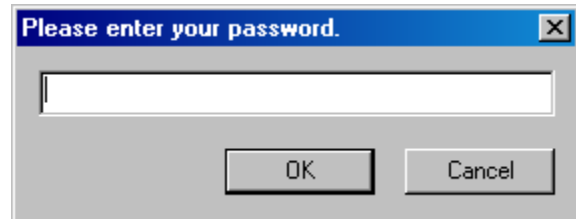

Update– The update command will copy the camera parameters in the current project to the camera in the `C:/GSI/System` directory. If the camera does not exist in the System folder, you have the option to copy it there. An update is tantamount to a camera re-calibration and should not be completed unless the network used to re-calibrate the camera was an especially strong one. The update command is password protected to prevent accidental implementation.



Delete – Delete the camera from the project. The camera is deleted to the Recycle Bin ( Recycle Bin) and can be retrieved if necessary.

Pictures Icon

Right click on the picture node [icon](#) or on any picture listed in the picture tree.

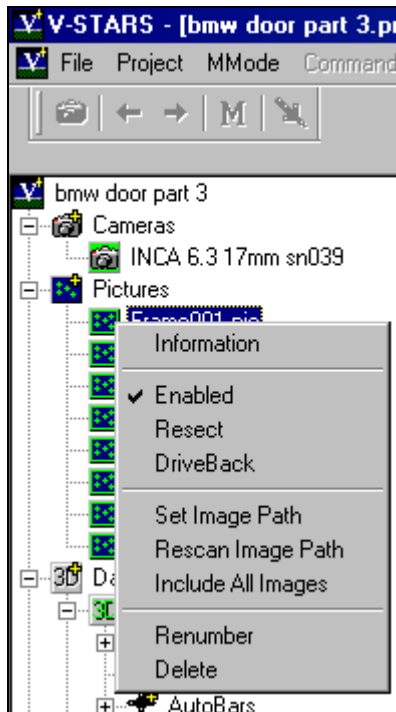

Information – Retrieve information about the current picture selected. The following dialog is opened. You can examine data related to the particular picture. This item is not available if the **Picture** node is selected.

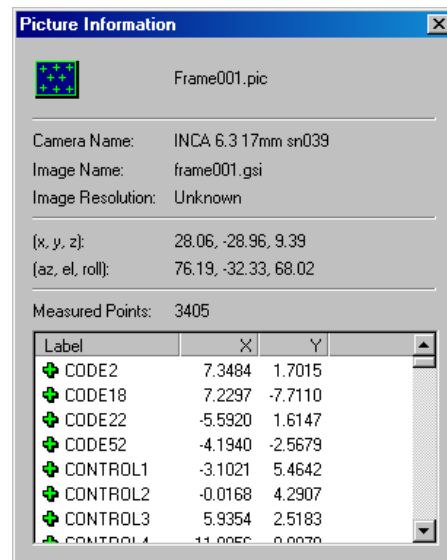

Enabled – Enable and disable images in the picture tree. If a particular picture is selected, then it is the only one enabled/disabled. To enable/disable multiple images, right click on the picture node. Disabled pictures will be displayed with a red line through a red circle.

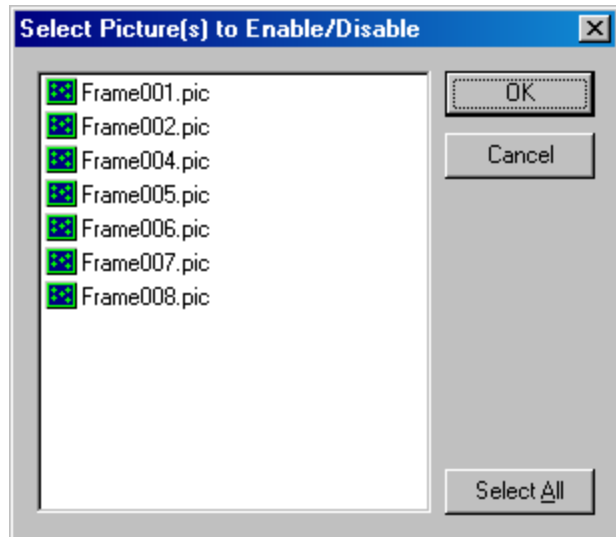

Resect – Open the image resection dialog. Refer to the Basics of Photogrammetry for more information on the Resection process.

If Resect is selected from the main Picture node then all the pictures can be resected from the one dialog. The **Rejection Limit** can also be set from within this dialog.

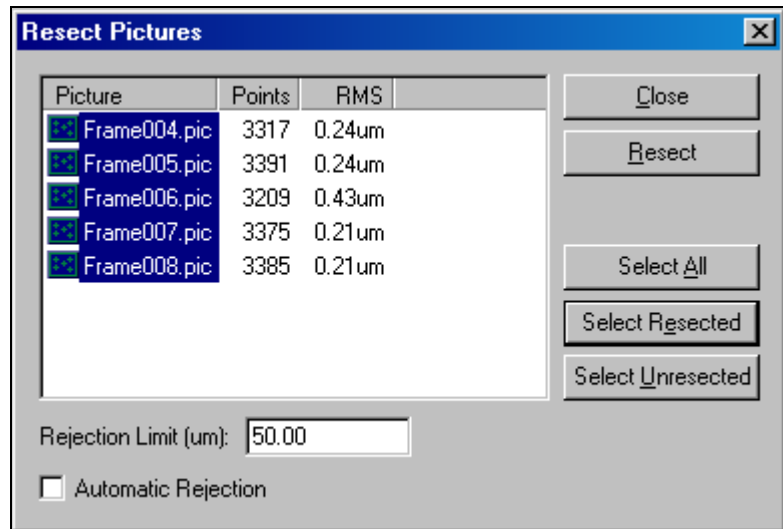

Driveback– The driveback command is used to check all the pictures for points that haven't been measured yet. It is especially useful when new points have been added to the project via triangulation process. The number of new points found in each picture and the RMS closure is displayed.

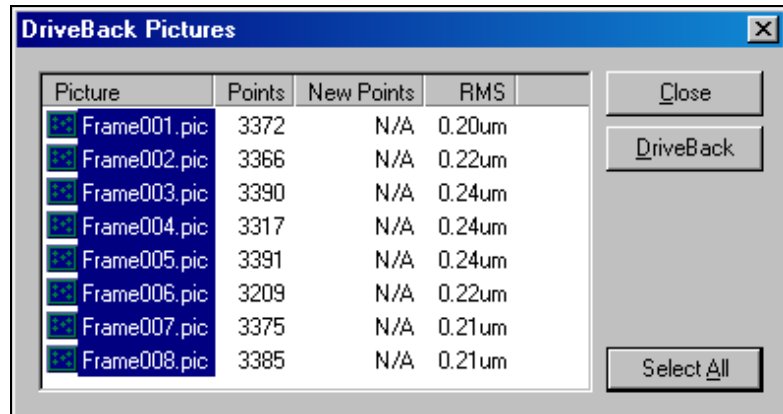

Set Image Path – Opens a file dialog box that is used to locate the image directory.

Rescan Image Path – Checks the image path for any new images. This is typically used when pictures have been added to the project.

Include All Images – Searches the image path and re-imports any images that were previously deleted or added.

Renumber – Renumber the images from the lowest available number.

 Images in the Recycle Bin must be deleted in order to reclaim the numbers associated with deleted files.

Delete – Delete the picture from the project.

 The physical image is **NOT** deleted, only the V-STARS reference to that picture (the pic file). The picture can be restored from the Recycle Bin or added using the **Include All Images** command.

Data Icon

Right click on the data node [icon](#), on any file listed in the data tree or any of the objects listed in the individual 3D files.

New – A new data file can be created using the **Data File** command. A new point can be added to any file using the **Point** command. It is also possible to create a new construction object from the New menu. Please refer to Construction Object section for a full explanation.

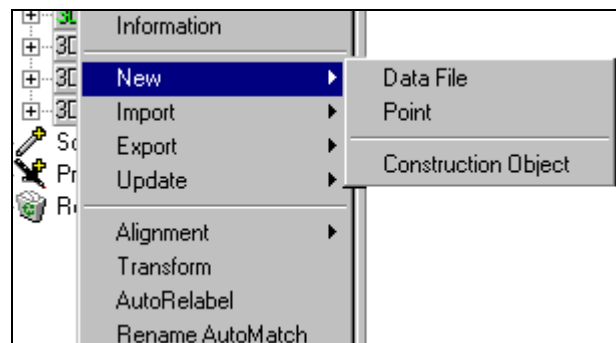

Import - The Import command allows you to import various files or objects into a V-STARS project or file.

AutoBar – Add an AutoBar to the project. This is very useful for customers with multiple AutoBars. Typically, the AutoBar is imported automatically for you at the start of the AutoMeasure routine. Refer to the Import section of the manual for more information.

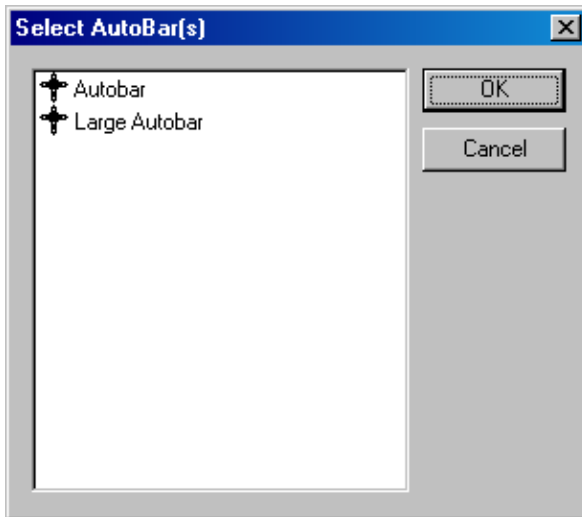

Construction Data – Import the construction objects of the selected file into the construction area of the right-clicked file. This is useful to transfer previously created construction objects into a 3D file.

Offset – Import offset values for individual points via an offset file. The offset values are added to the offset column for each of the points listed in the offset file. The offset file has the following format:

```
Point Label      Offset
```

The file should be saved with a *.txt extension.

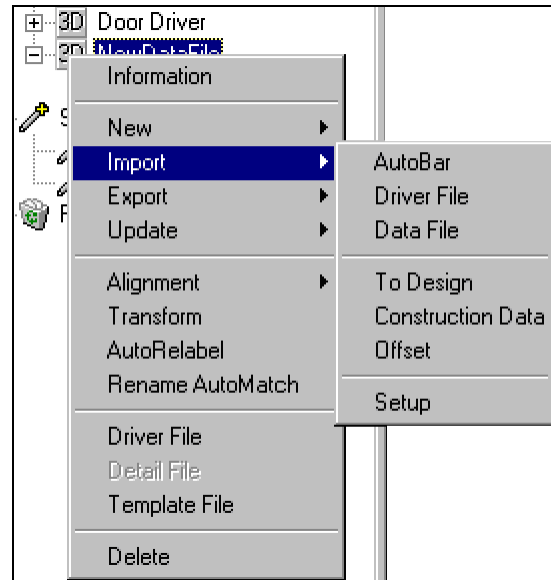

Driver File – Import a new driver file into the V-STARS project. Refer to Import Driver File section of the manual for more information.

Data File – Import a data file in to the project. This is done via the standard Open File Dialog.

To Design – Import the points of the selected data file in to the design area of the file that was right clicked. This is done via the standard Open File Dialog.

Setup – Enter the setup dialog for the IGES import. The options are shown in the adjacent image.

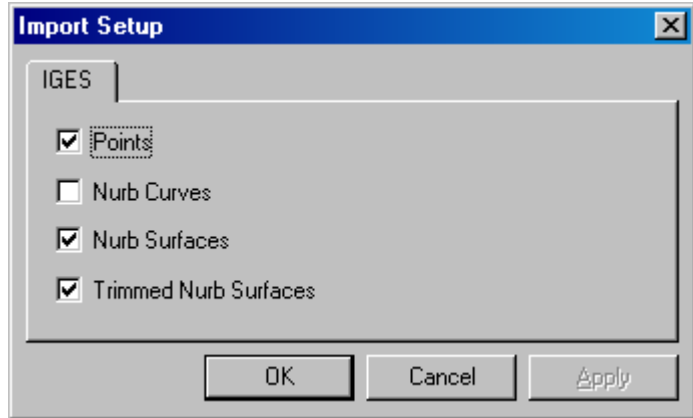

Export– The Export command allows you to export 3D files or points from V-STARS into other file formats.

IGES – Export points, lines, circles, planes, etc into an IGES format.

VDA – VDA is a common automotive file format. The file outputted must be the driver file. If a regular data file is selected the VDA option will be dimmed out.

V-SURF – Export V-SURF surface measurements to an output file. **A V-SURF license is required.**

3D – Export a 3D file into a new 3D file.

AAT – Export data to a Caps NT file format. The file outputted must be the driver file. If a regular data file is selected the AAT option will be dimmed out.

Delcam – Export data to a Delcam file format. The file outputted must be the driver file. If a regular data file is selected the Delcam option will be dimmed out.

ECDS – Export points into the ECDS file format. This is a data file based the ECDS theodolite system.

ManCat – Export points to the ManCat file format. This is a data file based the ManCat theodolite system.

Metrolog – Export points to the Metrolog file format.

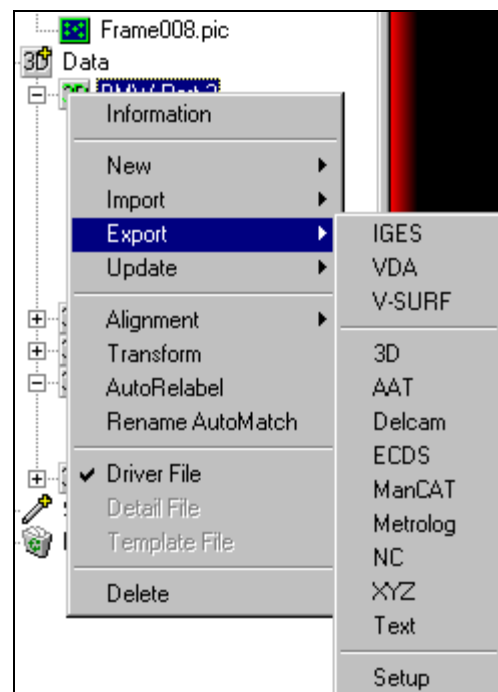

NC – Export points to the NC (Numerical Control) file format.

XYZ – Export points to an XYZ format as space delimited. The format exported is

```
Pt Label X Y Z Sigma X Sigma Y Sigma Z Offset
```

Text – Export points to a text format as space or tab delimited. This is set in the Setup dialog. The default format exported is

```
Pt Label X Y Z Sigma X Sigma Y Sigma Z Offset
```

Setup – Change the export options for V-SURF and Text Export. The following dialogs are available.

Text – Swap between **Tab** and **Space** delimited. The output fields can also be selected.

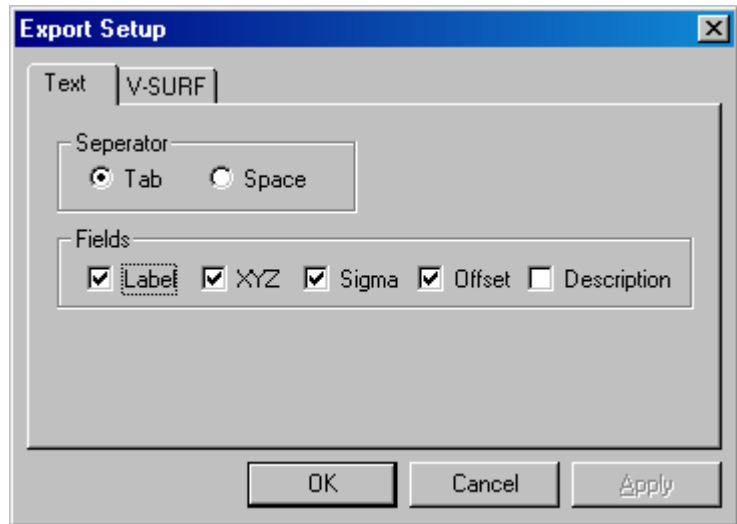

V-SURF - Swap between **Tab** and **Space** delimited. The output fields can also be selected modified.

The points can also be sorted by **Label**, **X**, **Y**, **Z** or **Total** residual.

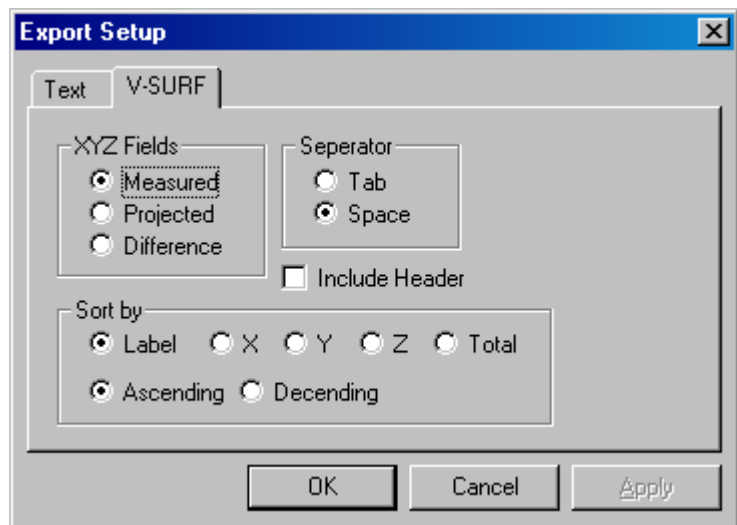

Right-click on Design Points

By right clicking on the design point's icon, a number of options are available. These are shown in the adjacent image.

Export – A number of export files options are available. An explanation of these can be found in the previous section. If the Design folder is right-clicked, an IGES export is also available.

Moved to Measured – move the Design points to the measured folder.

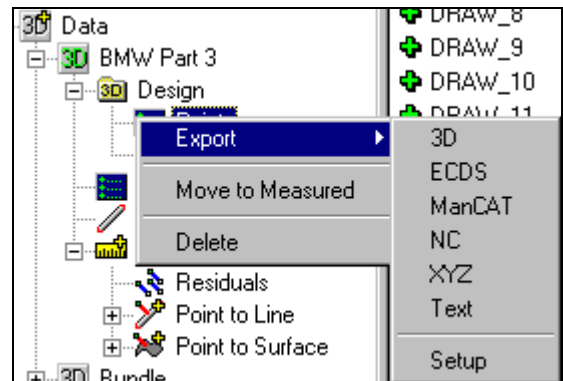



Delete – Delete the entire folder or parts of the folder.

Right-click on Multiple 3D Files

Merge - You can merge several 3D files into a single 3D file using the Merge command. Points with the same label are averaged, and the average values of the points are written to the merged file.

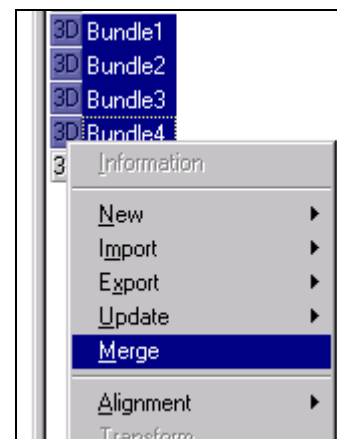
To merge a number of files, select the files you want to merge and select the **Merge** command. A dialog box will appear. Enter the name of the merged data file in the field. Press the **OK** button. The 3D file with the merged data will be saved in the current project. If **Merge** is grayed out, you have not selected at least two 3D files.



 Ensure data is in the same coordinate system prior to merging. Merging unaligned data sets will produce unpredictable results.

Right Click on Points in Design

Solids – Pass highlighted points into a Solids function. Refer to the SOLIDS Section for more information.





Copy – Highlight points and select **Copy** to copy them to the clipboard.

Paste – Paste points from the clipboard to the 3D file.

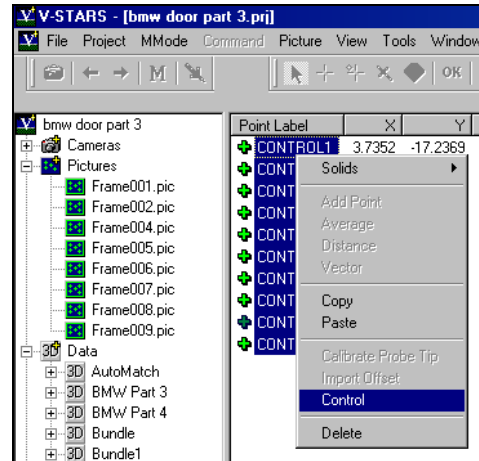
Delete – Highlight points and select **Delete** to delete them from the Design folder.

Control – Points in the Design folder can be set as control points. Control points are held fixed in the bundle process. To create control points, highlight the points you wish to mark. Right click over the points and select the **Control** option. Points marked as control will be displayed with a different icon.



	CONTROL1	3.7352	-17.2369
	CONTROL2	3.4914	
	CONTROL3	3.2584	
	CONTROL4	3.0238	

Right-click on Measured Points

By right clicking on the measured point's icon, a number of options are available. These are shown in the adjacent image.

Export – A number of export files options are available. An explanation of these can be found in the previous section.

Moved to Design – move the Measured points to the Design folder.

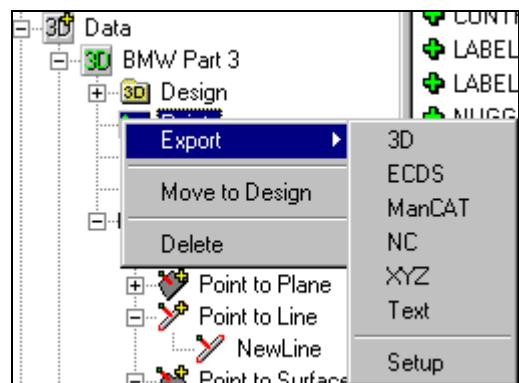

Delete – Delete the all the points in the folder.

Right-click on Created Objects

By right clicking on objects created in V-STARS such as Planes, Lines, Circles etc. a number of options are available. The options available will depend on the type of object. The adjacent image shows the plane options.

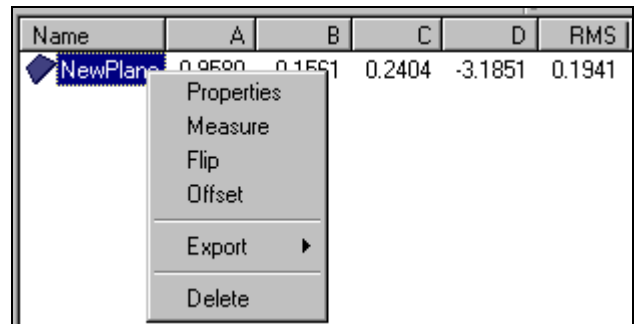

Properties – Display the properties of the object.

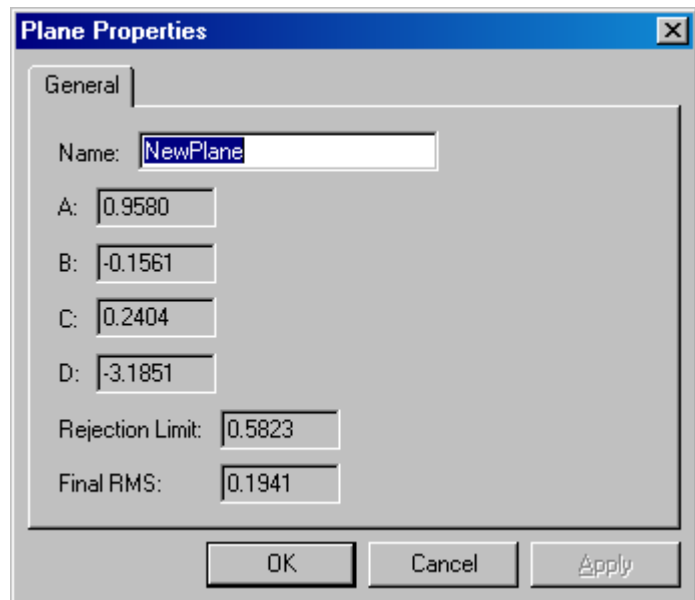

Measure – Create a measurement to that object. The objects available for measurement are listed.

Check the **Design** check box to measure to Design objects.

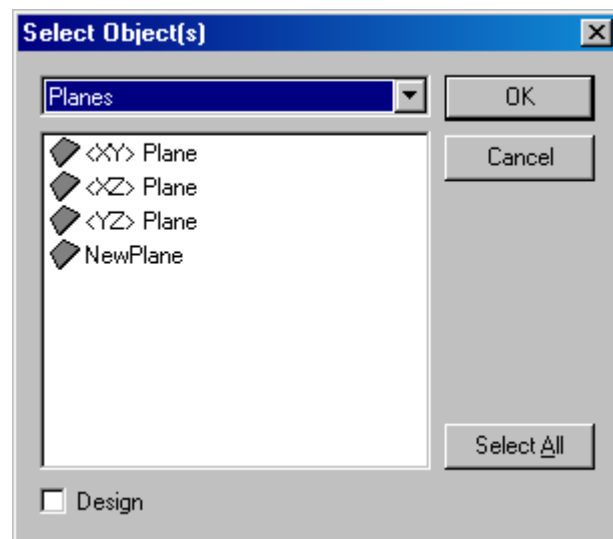

Additional objects can be located by changing the pull down menu to another object type.

Flip – Flip the positive direction of the object. Only available for planes and surfaces.

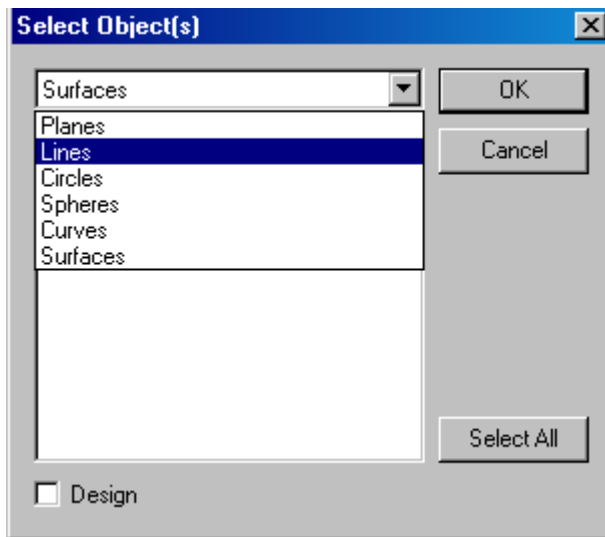

Offset – Offset the plane and create a new plane. The adjacent dialog contains the offset options available. The original plane can be deleted by selecting the **Delete Components** check. The plane is offset in the direction of the plane normal, unless the offset value entered is negative. Refer to the SOLIDS section on Plane Offsets for more information.

Export – Export the selected objects to a **Text** or **Tabbed Text** file. Any information found in the property section will be written to a text file. This text file can be directly imported into Excel.

Delete – Delete the selected objects.

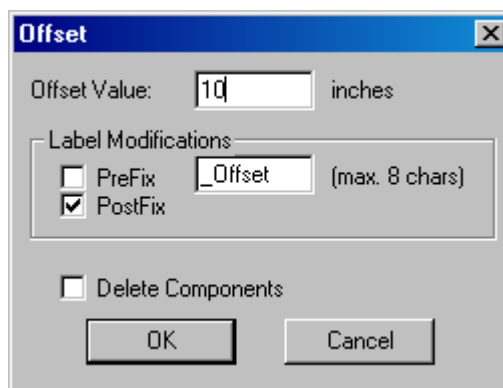

Name	A	B	C	D	RMS
NewPlane	0.9580	-0.1561	0.2404	-3.1851	0.1941
NewPlane1	0.9743	-0.1939	0.1147	0.8626	0.0000
Newf		0.4348	0.7382	-27.3834	0.0840
Newf		0.1351	0.0651	0.5702	0.0010

Right-click on Measurement objects

By right clicking on objects in the measurement section, it is possible to export the measurement results directly to a .txt file.

Point Label	Proj X	Proj Y	Proj Z	Delta X	Delta Y	Delta Z	Total	Offset
+ TARGET4	-1.1651	-15.8935	-6.5416	-0.0002	0.0000	-0.0000	-0.0002	0.0000
+ TARGET5	-1.1896	-15.8126	-6.0016	0.0009	-0.0001	0.0001	0.0009	0.0000
+ TARGET6	-1.1762	-16.0654	-6.7301	-0.0004	0.0001	-0.0000	-0.0005	0.0000
+ TARGET7	-1.2142	-15.7364	-5.4699	-0.0013	0.0002	-0.0001	-0.0013	0.0000
+ TARGET8	-1.2007	-15.9838	-6.1889	0.0016	-0.0002	0.0001	0.0016	0.0000
+ TARGET9	-1.1972	-16.2262	-6.9171	-0.0006	0.0001	-0.0000	-0.0006	0.0000

Right click on distance measurements to convert these to Scalebars.

Point Label 1	Point Label 2	DX	DY	DZ	Total	Sigma
CONTROL1	CONTROL2	1.2674	5.8881	6.1660	8.6195	0.0004

Update –The update command is used to update the values of objects within V-STARS.

AutoBar – Deletes the current project AutoBar and replaces it with the update project AutoBar values.

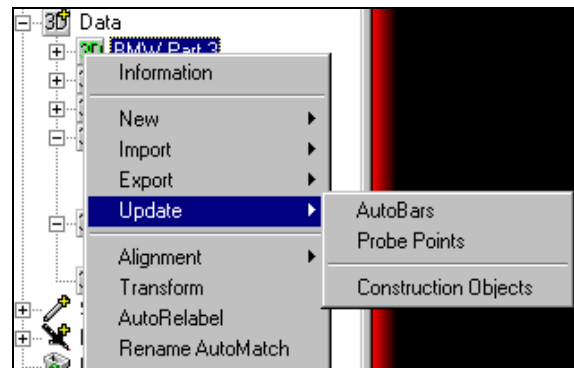

Probe – This option is only available when there are probes in the project. Any probe measurements present will be updated using the probe calibration values in the project. This option is useful for instances when the probes used in a measurement are recalibrated after the measurement. The new calibrations can then be applied to the original measurements.

Construction Objects – Update or add any of the construction object found in the 3D file. Construction objects are typically updated automatically after a bundle.

Alignment – The alignment menu accesses the V-STARS alignment functions. Please refer to the Alignment Section of the manual for more information.

Residuals – Quick

View the results of a Quick alignment. From this dialog it is also possible to re-calculate the transformation using a different rejection factor.

Residuals – Standard

View the results of a Standard alignment. From this dialog it is also possible to re-calculate the transformation using a different rejection factor.

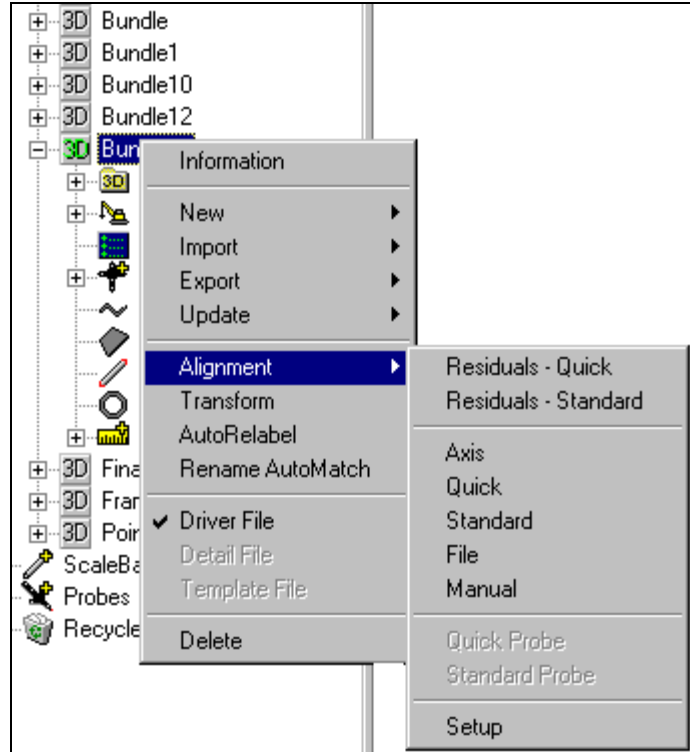

Axis– Initiate an Axis alignment. Select the Anchor Point, Axis Point and Plane Point. The Anchor Point coordinate value can also be set from the dialog window. Use the radio buttons to set the axis directions. Refer to the Alignment Section for more information.

Quick – Initiate a Quick Alignment. Refer to the Alignment Section for more information.

Standard – Initiate a Standard Alignment. Refer to the Alignment Section for more information.

File – Select the File option to display a dialog from which a file with pre-defined transformation values can be loaded. Transformation files from CATS, HOLOS, and GSI are currently supported.

Manual – Manual shift, rotate or scale a 3D file. To shift the data in X, Y or Z, type the shift values in the boxes and press the **Begin** button. The value in the boxes will be added to every point in the file.

To rotate the data around the X, Y, or Z axis, enter the rotation value in the appropriate box, and press the **Begin** button. You may only rotate around one axis at a time. A positive value rotates counter-clockwise around the axis as viewed down the positive axis.

To scale the data enter a value in the scale box and press **Begin**. Every point coordinate will be multiplied by the scale value.

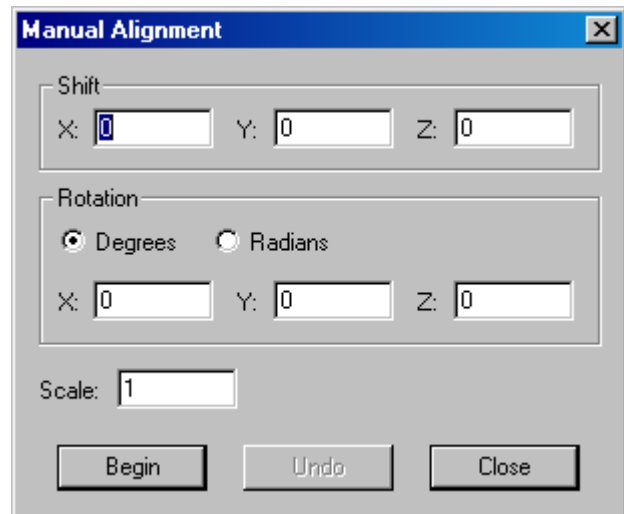

The Manual Alignment dialog box has a blue title bar with the text "Manual Alignment" and a close button (X). It contains three sections: "Shift" with input boxes for X, Y, and Z, all containing the value "0"; "Rotation" with radio buttons for "Degrees" (selected) and "Radians", and input boxes for X, Y, and Z, all containing "0"; and "Scale" with an input box containing "1". At the bottom are three buttons: "Begin", "Undo", and "Close".



The **Undo** button will only undo the most recent alignment.

Setup – Modify the default alignment settings. By default the scale in the Quick and Standard are allowed to adjust. By default the **Automatic Rejection** is also enabled. If the **Automatic Rejection** is disabled, then the **Rejection Limit** can be set. The convergence limit and the maximum number of iterations can also be set.

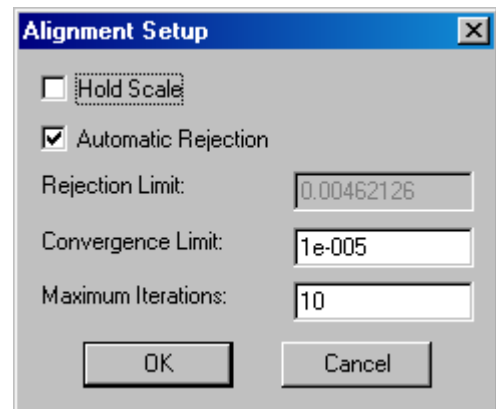

The Alignment Setup dialog box has a blue title bar with the text "Alignment Setup" and a close button (X). It contains several settings: a checkbox for "Hold Scale" which is unchecked; a checkbox for "Automatic Rejection" which is checked; a "Rejection Limit" input box with the value "0.00462126"; a "Convergence Limit" input box with the value "1e-005"; and a "Maximum Iterations" input box with the value "10". At the bottom are two buttons: "OK" and "Cancel".

Transform – The Transform option loads the Transformation Wizard dialog. Follow the instructions to complete the transformation process.

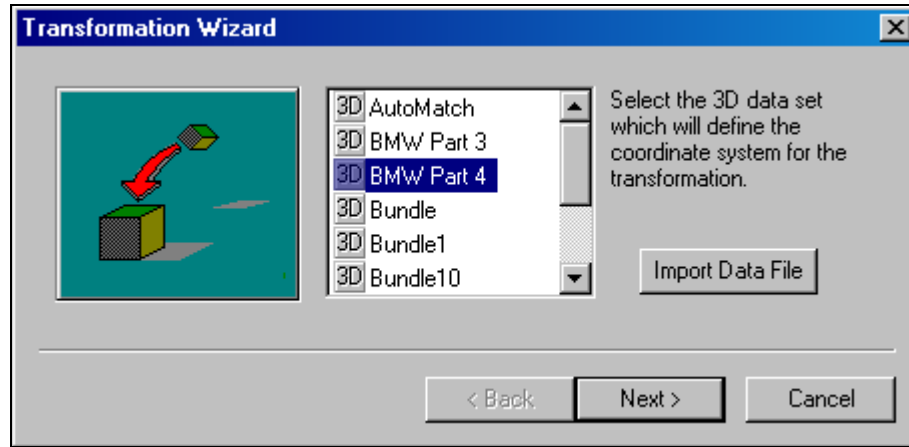

Press the **Import Data File** button if the file is not already in the 3D folder.

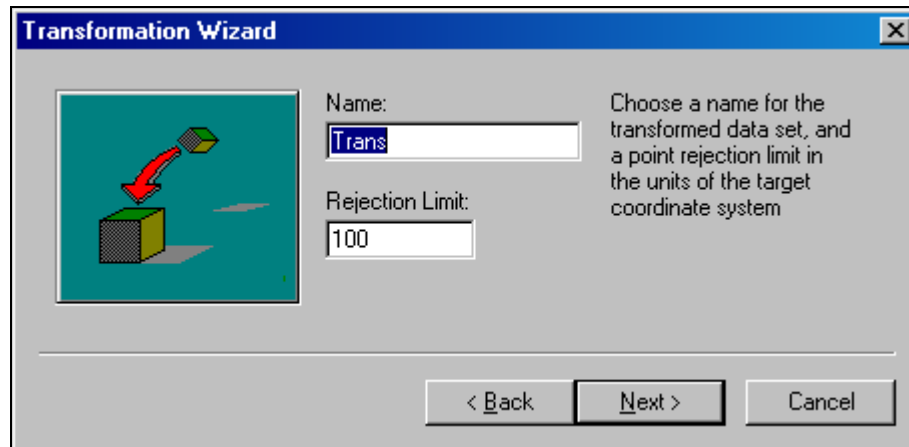

Enter a name for the new transformed data set and a rejection limit to use for the transformation. Press **Next** to continue to the next step of the transformation.

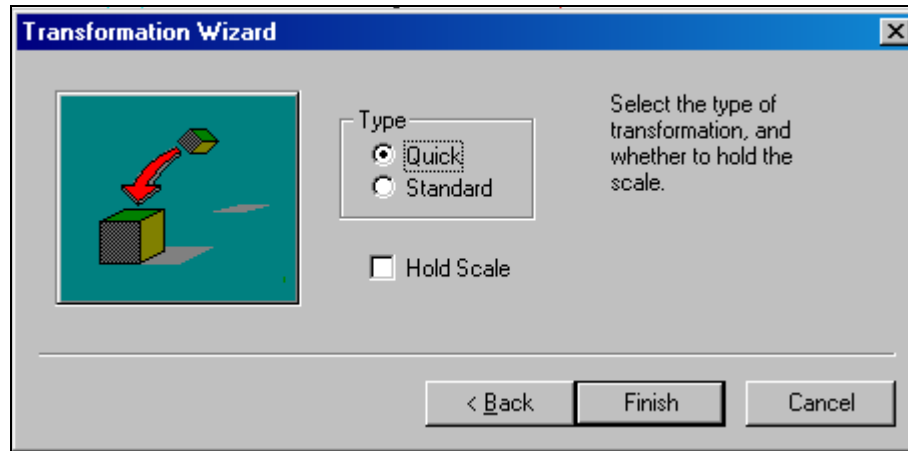

Select the type of transformation and whether the scale needs to be held. A **Direct** transformation is a simple subtraction between the two data sets. Press the **Finish** to process the transformation. The results are displayed in a WinTrans dialog. Refer to the WinTrans manual for more information.

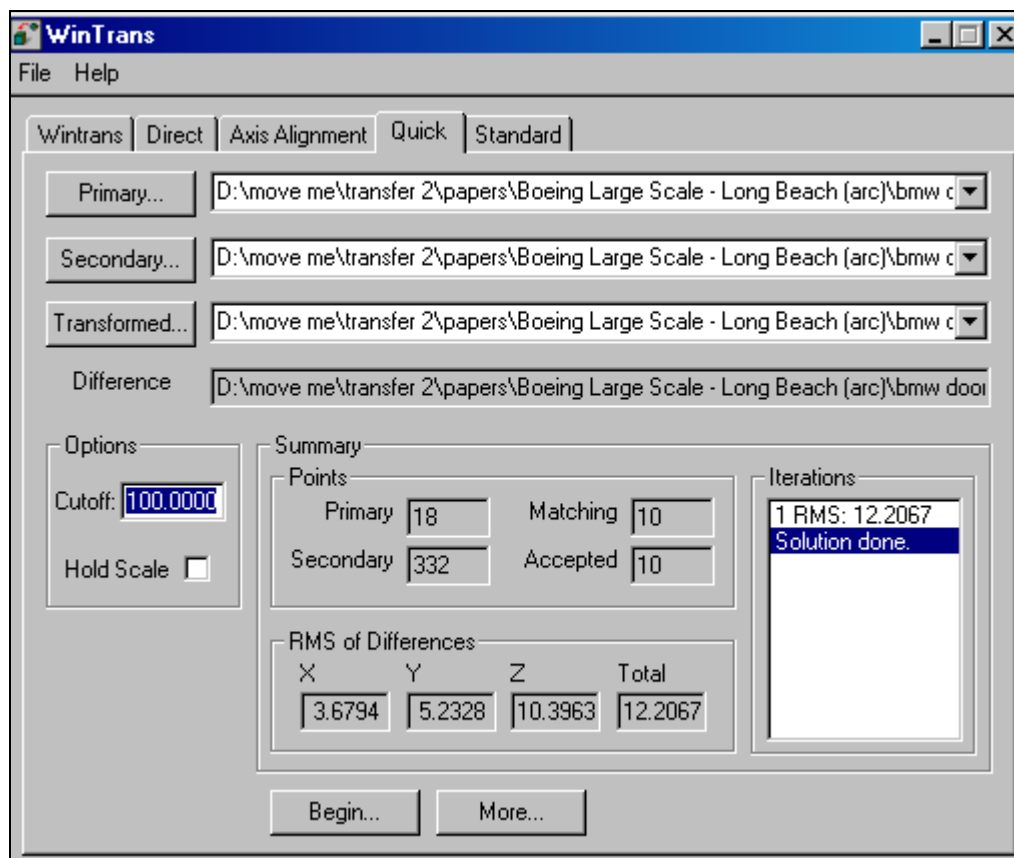

AutoRelabel– The AutoRelabel option loads the **AutoRelabel Wizard**.

AutoRelabel is an automated way to transfer the labels of one set of points to another set of points. In order to work, there must be common points between the two sets. These common points are used to compute a transformation. Once transformed, points that fall within a nearness threshold have their labels transferred.

Follow the instructions to complete the automatic relabeling process.

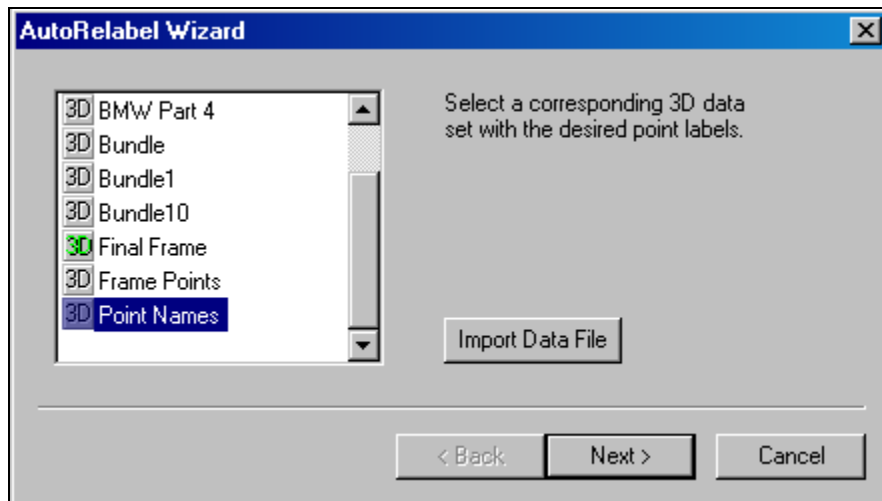

Start by selecting the file that contains the labels you wish to transfer. Press **Next** to continue.

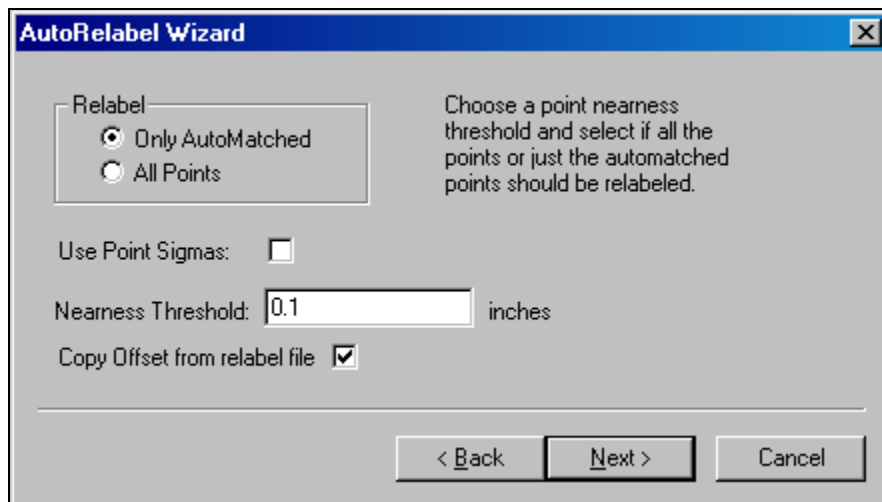

A **Nearness Threshold** will be selected automatically depending on how well the common points transform. You have an option to Relabel all the points or only points that have been AutoMatched. The **Only AutoMatched** is selected by Default. If the label file contains point offset information it will be copied over if the **Copy Offset** is set to true. Press **Next** to continue.



The number of points missed by the AutoRelabel will be listed. To view the missing points, select the **Show Missed Points** command. If you still wish to try and relabel the missed points, press the **Back** command to go back a step and increase the **Nearness Threshold**. Press **Finish** to close the dialog.

Rename AutoMatch – Use this option to automatically group relabel points in the 3D file to another starting label. Only points that start with the key word **TARGET** will be relabeled. If the Driver file is relabeled then all the corresponding observations will also be relabeled.

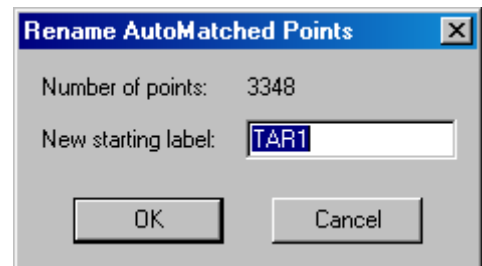

Driver – Set the current 3D file as the driver file. If the file is already the driver file then it will become a normal 3D file.

If a 3D file is selected as a driver, you will be prompted to re-rectify all the pictures in the project.

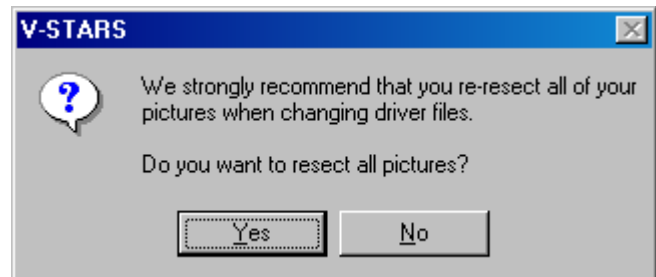

Detail– Set the current 3D file as a detail file. This option is only available if the cameras are in M Mode. Please refer to the M Mode Manual for more information.

Template– Set the current 3D file as a Template file. This option is not available for the current driver file. The Template function is used to activate Feature Targets. Feature Targets are special calibration files. Right click on the Template file to make it **Active** or to remove the Template status.

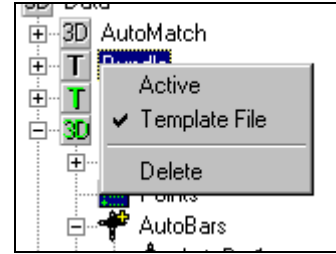

Delete – Delete the current file from the project. The 3D is deleted to the Recycle Bin and can be retrieved if necessary.

ScaleBars Icon

Right click on the ScaleBars menu to add, modify or remove scale bars.

New – Create a new scale bar using the following dialog.

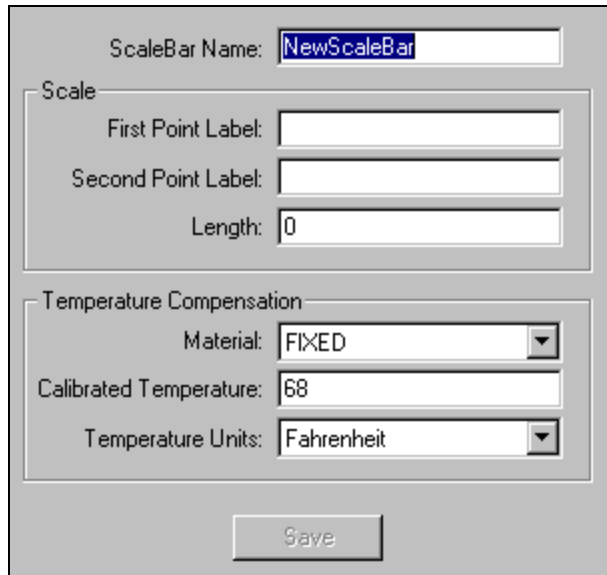

The 'New Scale Bar' dialog box contains the following fields and controls:

- ScaleBar Name:
- Scale section:
 - First Point Label:
 - Second Point Label:
 - Length:
- Temperature Compensation section:
 - Material:
 - Calibrated Temperature:
 - Temperature Units:
- Save button

Add – Add a scale bar from the system directory or browse for one from the computer or network.

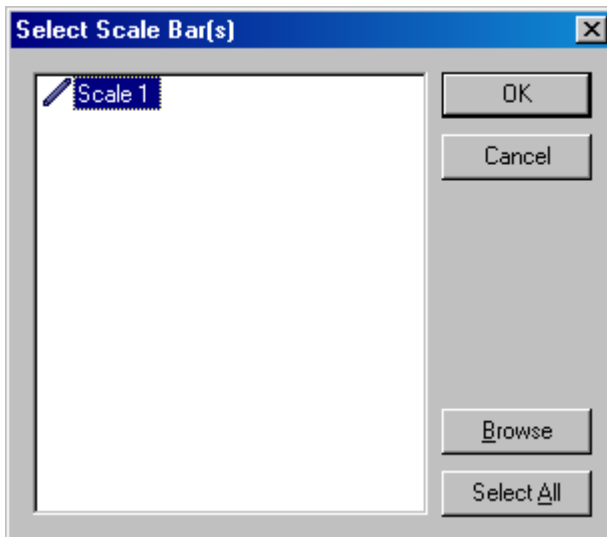

The 'Select Scale Bar(s)' dialog box features a list box containing 'Scale 1' and the following buttons:

- OK
- Cancel
- Browse
- Select All

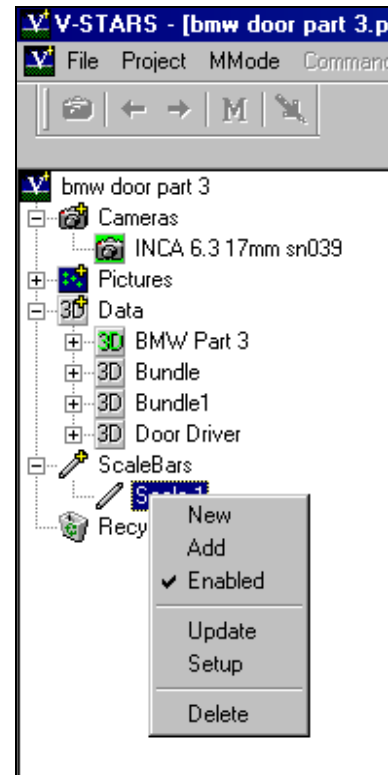

Enabled – Enable or disable a scale bar.

Update – The update command will copy the scale bar parameters from the current project to the scale bar in the C:/GSI/System directory. If the scale does not exist in the System folder, you have the option to copy it there. An update is tantamount to a scale bar re-calibration. The update command is password protected to prevent accidental update.

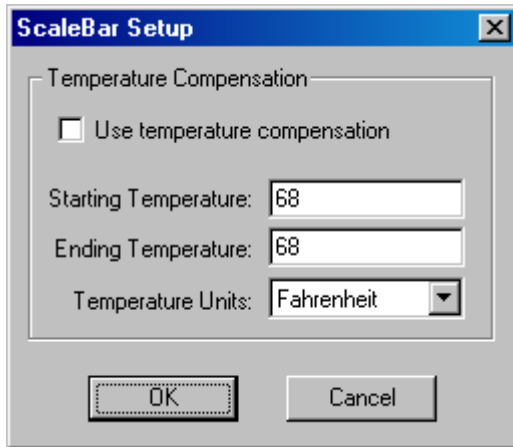

Setup – Implement temperature compensation. **Check the Use Temperature Compensation** to implement the temperature compensation. Enter the temperature at the start and at the end of the photography.

Delete – Delete the scale bar from the project. The scale bar is deleted to the Recycle Bin and can be retrieved if necessary.

Recycle Bin Icon

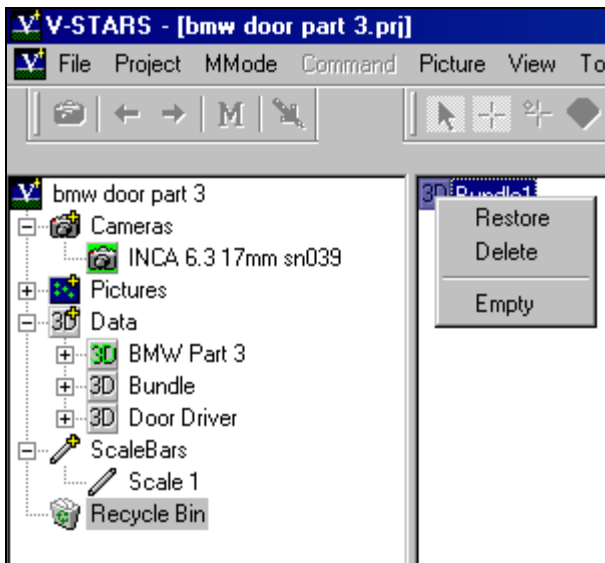

Right click on the Recycle bin menu to restore or delete items placed in the Recycle Bin. Use the **Restore** function to restore individual files or the **Empty** command to empty the entire bin.

Right Click on Picture Thumbnails

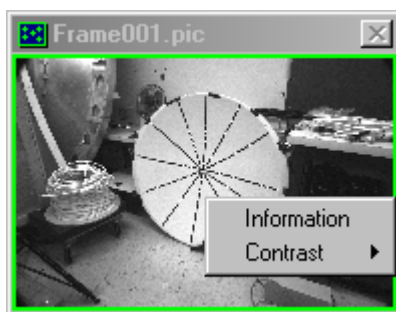

Information – Retrieve information about the current picture selected. You can examine data related to the particular picture.

Contrast– Adjust the viewing contrast of the thumbnails. The Auto setting selects the optimal contrast setting.

Right Click in Picture

SuperStart

The **SuperStart** command will reset the open picture and complete the following processes:

1. Scan image for potential targets.
2. Determine the whether an AutoBar is present.
3. Decode any codes that are present.
4. Use the known (in XYZ) coded targets and AutoBar found to determine the location in space (resection) of the image.
5. Driveback to any points in the Driver file.

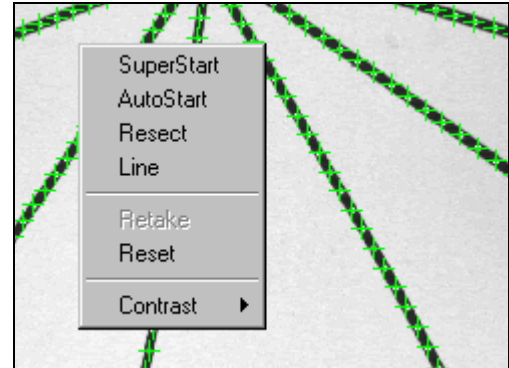

If the frame has been measured previously then You will be warned before the image is reset.

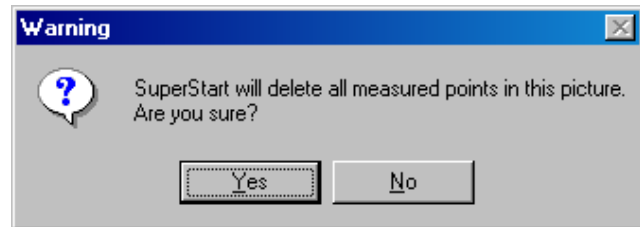

AutoStart

The **AutoStart** command will use the existing resection values to driveback to the points in the driver file. Any points already measured in that frame will be skipped.

Resect

The **Resect** command will open the resection dialog. The dialog displays the position (XYZ) and attitude (Az, El, and Roll) of the camera in space.

The **Rejection Limit** can be adjusted and the resection re-run by using the **Resect** button. By selecting **Automatic Rejection**, the software determines the optimal rejection limit.

In the residuals frame all the rejected points can be removed by selecting the **Delete Rejected Points** command. Individual observations can also be enabled, disabled or deleted by right clicking over the points you wish to modify and selecting one of the options. Refer to the Basics of Photogrammetry for more information.

Line – The line command is a search function to label or relabel points automatically. The command will only be active after two points have been measured or renamed. The search is performed based on the distance and angle between the two previous points.

Retake – Retake the current picture. This command will only be active if the camera is online.

Reset – Delete all the measurement and reset the picture.

Contrast – Adjust the viewing contrast of the pictures. The Auto setting selects the optimal contrast setting.

Right Click in Graphical View

Right Clicking in the Graphical View produces the menu in the adjacent image.



Solids

To use any of the measurement objects that use SOLIDS objects or Surfaces you must have a SOLIDS and/or Surface license.

Please refer to the SOLIDS section of the manual for an in-depth explanation of the Solids menu functions.

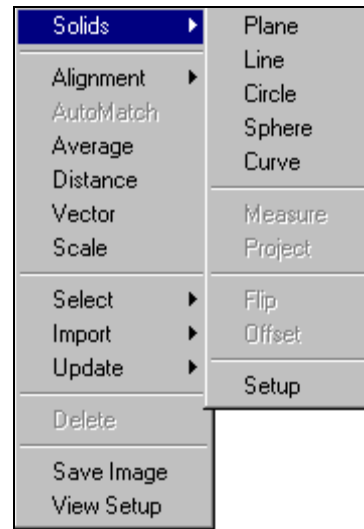

Alignment

Please refer to the Alignment section of the manual for an in-depth explanation of the different Alignment functions available.

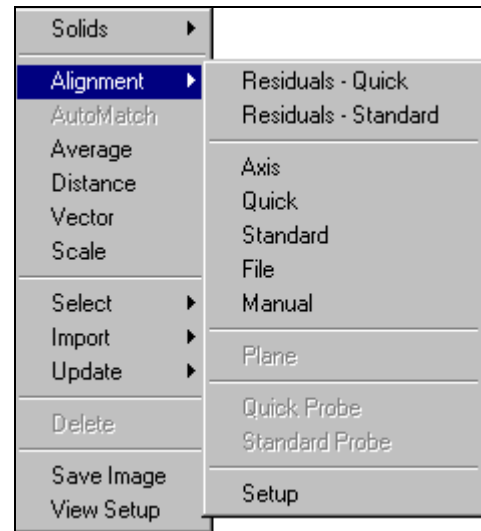

AutoMatch

To activate this option it is necessary to select three images to AutoMatch. In this mode of AutoMatch it is up to you to decide whether the combination selected is worth AutoMatching. A Triangle goodness number is displayed to help this decision process. A figure of greater than 20% is recommended. The AutoMatch generates a new "AutoMatch" file that becomes the driver file.

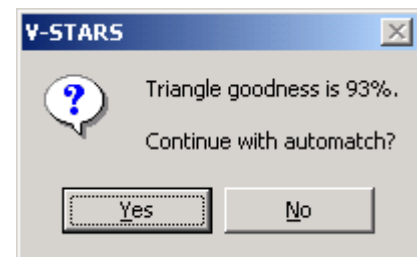

Average

Create the Average of a number of different points. Select the points and then select the **Average** command. Enter a name in the Label field and press OK to create the point. The Average command can also be reached by using the  key.

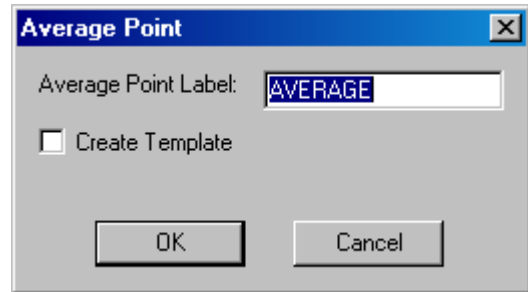

Distance

Compute the distance between two points. If two points are selected the distance will be computed immediately. If not, a point dialog appears and the two points must be selected. The Distance command can also be reached by using the  key.

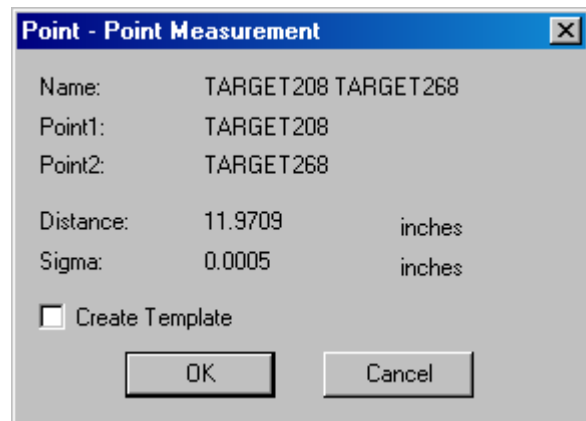

Vector

To create a vector point, select the two points that define the vector and select **Vector** from the right click menu or press the  key. The Vector Point dialog is displayed. Enter an offset and a new point label and press **OK** to add the point to the 3D file.

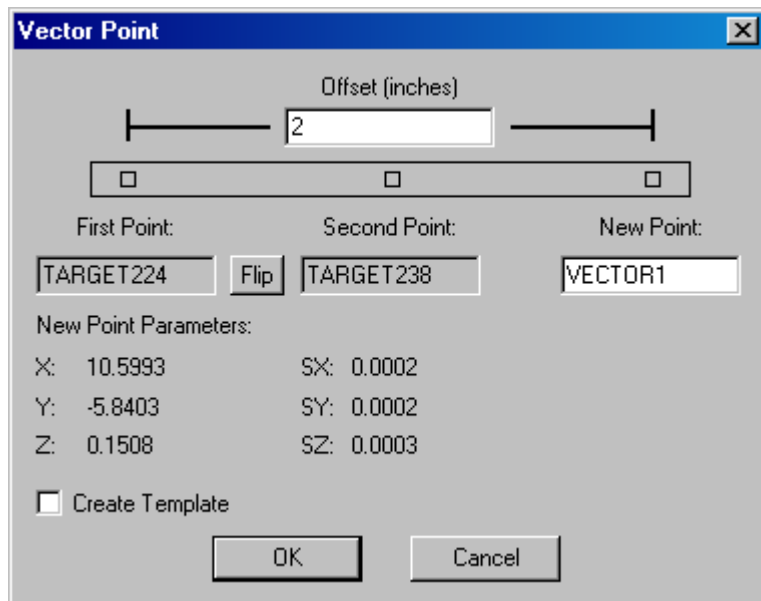

To create a point in the opposite direction, enter a negative number in the offset field. Refer to the Basic Measurement Sections for more information.

Scale

Apply the scale factor to the current 3D file. The **Scale** function is a convenient way to scale a 3D file without running the Bundle again. The results of the scaling are summarized in a dialog box.

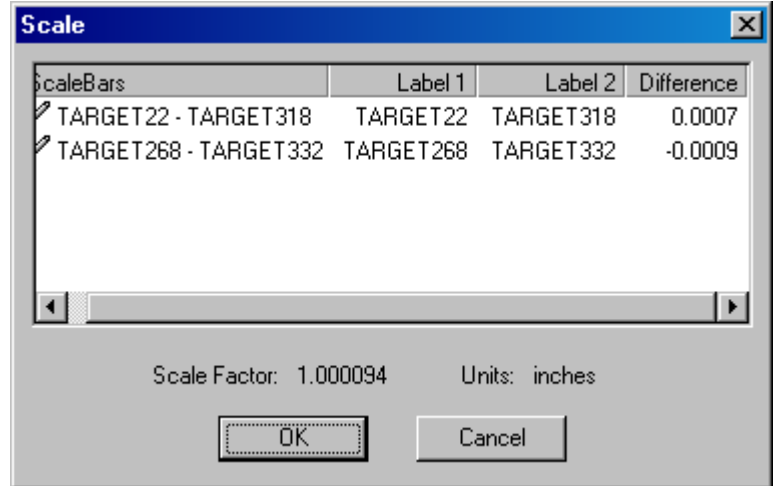

Select – A number of selections can be made using the Select function.

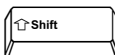
If the  is active multiple items can be selected without holding the  key.

Highlights – Select any points that have been highlighted. Points can be highlighted from the graphical setup.

Close Points – Select points that are within a distance tolerance.

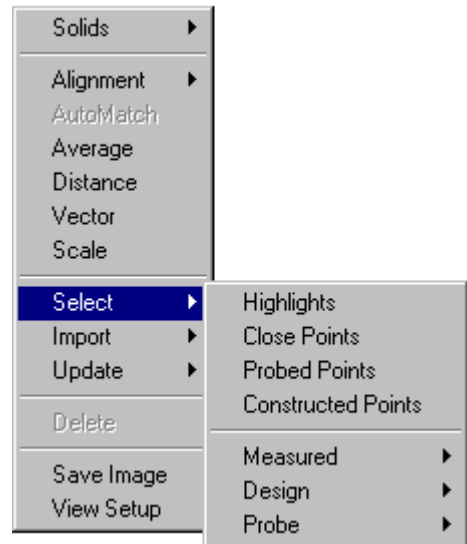
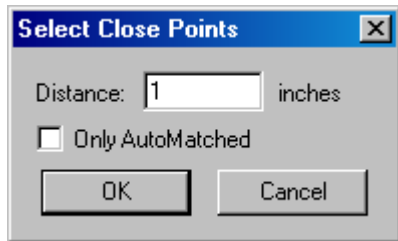

Probed Points – Select points that have been probed.

Constructed Points – Select points that have been constructed.

Measured

Select various Solids Objects that have been created that are in the Measured Folder.

Design

Select various Solids Objects that have been created that are in the Design folder.

Probe

Select points that are in the **Probe Folder**. Refer to the M Mode manual for more information.

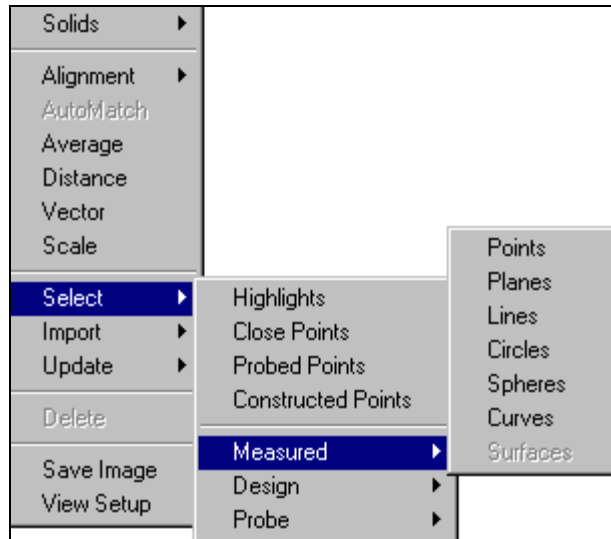

Import

To Design – Import the points of the selected data file in to the design area of the file that was right clicked. This is done via the standard **Open File** dialog.

Construction Data – Import the construction objects of the selected file into the construction area of the right clicked file. This is used to transfer previously created construction objects into a 3D file.

Setup – Enter the setup dialog for the IGES import.

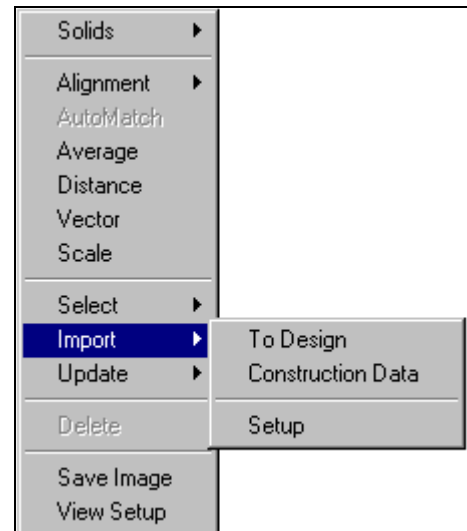



Update

Surface Measurements –Only available if a **V-SURF license** is present. This command will update any previous **Surface Measurements** made. This is necessary after either the surface of the point data has changed.

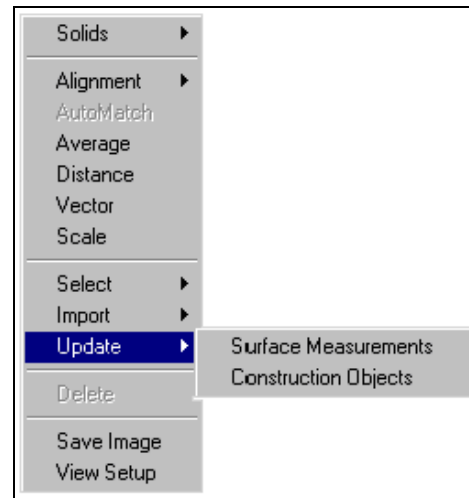
Construction Objects – Update or add any of the construction object found in the 3D file. Construction objects are updated automatically after a bundle.



Delete – Delete the selected objects

Save Image – Save the current graphical view to a BMP file. This file can be added to reports etc. To reverse the background on the file save open the **View Setup** dialog and select the **Display Colors Tab**. Check the **Invert Pt/Bkg on Save**. The view can also be save using the Windows   command.























This will paste the current view to the clipboard. From here is can be pasted to a Word document or any other Windows program that supports image data.

































View Setup – Open the View Setup dialog. Many display options are accessed through the View Setup dialog. The View Setup can also be accessed via the  key. Refer to the View Setup Dialog for more information.

Icons

Introduction

For convenience, the various icons used by V-STARS have been listed below. Where possible they have been listed in the order they would appear in a project.

-  V-STARS Project
-  Camera Folder
 -  Non-default Camera
 -  Default Camera
-  Picture Folder
 -  Resected Picture
 -  Un-resected Picture
 -  Un-measured Picture or No points found in Picture
 -  Disabled
-  Epoch Folder (M-Mode Only)
 -  Epochs
-  Data Folder
 -  3D File
 -  Design Folder
 -  Control Point
 -  Construction Folder
 -  Average Point
 -  Vector Point
 -  Curves
 -  Planes
 -  Lines
 -  Circle
 -  Spheres

-  Point List
 -  Measured Point
 -  Constructed Point
 -  Probed Point
-  Probe Folder
 -  Probe Folder Points
-  AutoBar Folder
 -  AutoBar
-  Surfaces
-  Curves
-  Planes
-  Lines
-  Circle
-  Spheres
-  Measurements Folder
 -  Residuals
 -  Point-to-Point
 -  Point-to-Point Curve
 -  Point to Plane Folder
 -  Point to Plane
 -  Point used in entity
 -  Point measured to entity
 -  Point to Line Folder
 -  Point to Line
 -  Point to Circle Folder
 -  Point to Circle
 -  Point to Sphere Folder
 -  Point to Sphere
 -  Point to Surface Folder
 -  Point to Surface
 -  Point to Curve Folder
 -  Point to Curve

 Plane to Plane

 Line to Line

 Line to Plane

 Current Driver File

 Detail File

 Template File

 Active Template File

 Scale Bars Folder

 Scale Bar

 Probe Folder

 Probe

 Empty Recycle Bin

 Filled Recycle Bin

 Job

 Good Picture

 Weak Picture

 Bad Picture

 Good Point

 Weak Point

 Bad Point

 Good Scale Bar

 Weak Scale Bar

 Bad Scale Bar

Tool Bars

 Selection Cursor













 Driver Point Cursor

 New Points Cursor

 SuperFind Cursor

 OK Mode Cursor

 Global Rename Cursor

-  Rename Cursor
-  Global Delete Cursor
-  Delete Cursor
-  Up One Level
-  Bring Project to Top
-  Show/Hide Zoom Window
-  Show/Hide Data Window
-  Take Picture
-  Previous Picture
-  Next Picture
-  Change to M Mode
-  Trigger















Keyboard Commands

Basic Keyboard Commands









View

Fit	
Fit to X axis	
Fit to Y axis	
Fit to Z axis	
Zoom in / out	/
Rotate CCW / CW	/
Rotate up / down	/
Rotate left / right	/
Shift up / down	/
Shift left / right	/
Translation multiplier Inc / Dec	/
Rotation multiplier Inc / Dec	/
Reset view settings	
Toggle X vector	
Toggle Y vector	
Toggle Z vector	
Toggle total vector	
Residual scale Inc / Dec	/
Measurement scale Inc / Dec	/
Resect Cameras	Select camera stations and then press

Display

Line width Inc / Dec	 / 
Point size Inc / Dec	 / 
Axis size Inc / Dec	 / 
Toggle point labels	
Label size Inc / Dec	 / 
Label skip freq. Inc / Dec	 / 
Toggle Picture Stations	
Toggle point rays	
Toggle 3D data file title	
Toggle tolerance bar	



Object Analysis and Creation

Plane	
Line	
Circle	
Sphere	
Measure	
Flip positive normal direction	
Point Distance	
Average Point	
Vector Point	

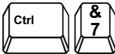
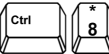

The use of the Plane, Line, Circle and Sphere commands requires a SOLIDS software license. The use of the Measure command requires a SOLIDS or Surface software license.

Surface Analysis

Display stroke Inc / Dec	 / 
Display resolution Inc / Dec	 / 

Enable / Disable selected surfaces



Enable all surfaces

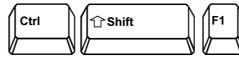

Advanced Keyboard Commands

Toggle orthographic / perspective



Field of view Inc / Dec



Tool Tip timeout, Inc / Dec



Undo timeout, Inc / Dec



Undo previous view modification



Crosshair size divisor, Inc / Dec



Single selection precision, Inc / Dec



Near clipping plane, Inc / Dec



Far clipping plane, Inc / Dec



New Keys

There are now some new hot keys that make V-STARS faster and easier. The following keys have been added since 4.1

Enable / Disable Picture Stations



Select the Stations first

Resect Selected Picture Stations



Select the Stations first

Display stroke Inc / Dec



V-SURF feature only

Display resolution Inc / Dec



V-SURF feature only

Display resolution Inc / Dec



Curve Analysis

Display View Setup



Display the 3D view setup

Index

3D Viewer.....	53
Additional Display Options	69
Delete and Rename Points.....	57
Entity Identification	56
Fitting the view.....	54
Introduction.....	53
Multiple Selection	56
Panning.....	53, 55
Rotating	54
Selection.....	55
Selection Types.....	55
Single Selection	56
Using the keyboard.....	54
Using the mouse	53
Viewpoint	53
Viewpoint Manipulation.....	53
Zooming.....	54, 55
Alignment.....	71
Axis.....	71, 80
Changing Standard Deviation Fields	81
File.....	72, 83
Introduction.....	71
Manual.....	72, 84
Options	79
Quick.....	71, 81
Residuals.....	79
Setup.....	84
Standard.....	72, 81
Alignment Setup	181
AutoBar	
Import.....	148
View	62
AutoMatch.....	23, 191
AutoMeasure	
Components.....	22
Dialog.....	24
Flow Chart	22
AutoMeasuring.....	22
AutoRelabel.....	183
Average	85, 192
Construction Objects.....	116
Axis Alignment.....	71, 80, 180
Axis Size.....	63
Basic Measurement Functions	85
Average.....	85

Introduction.....	85
Vector	86
Browse For Images.....	5
Bundle.....	29, 38
Dialog.....	31
Overview	29
Running a	29
Setup.....	38
Sub-Sampling	39
Summary Dialog	29
Bundle Statistics.....	41
Bundle Automatic Scale Rejection	45
Criteria Tests	41
Icons.....	42
Introduction.....	41
Median Test (M).....	41
Number Test (#).....	41
Percentage Test (%).....	41
Value Test (V).....	41
Viewing Picture Summary	42
Viewing Points Summary	43
Viewing Scale Summary.....	45
Center of Rotation.....	70
Circle.....	91
In Plane	58
Out Plane	60
Clipping Planes	70
Color Gradient	67
Color Schemes	68
Column	
Changing Selected Entries	81
Changing Single Entries.....	83
Modify the Contents of an Entire Column.....	81
Command Menu	156
AutoStart.....	157
Find.....	158
Line	158
Next String	158
Resect	157
SuperStart	156
Target Search	158
Construction Data	
Import.....	194
Construction Objects	114
Average.....	116
Importing	115
Introduction.....	114
Measurement Objects.....	119

SOLIDS.....	118
Update.....	195
Vector.....	115
Continuous Trigger Delay.....	137
Contrast - Picture.....	188
Control.....	176
Marking.....	33
Copy Points.....	176
Curves.....	94
Data File	
Import.....	149
Default Camera.....	168
Delete	
Pictures.....	170
Delete	
Points.....	57
Design Data.....	72
Comparing to Measured.....	74
Creating.....	77
Driver File with Design Points.....	78
Importing.....	73
Importing Data from a File.....	77
Introduction.....	72
Viewing Differences Graphically.....	75
Detail File.....	185
Display Options.....	58
Distance.....	86, 192
Driveback Pictures.....	170
Driver	
Import.....	149
Set From Existing Data File.....	14
Export.....	173
3D.....	173
AAT.....	173
Delcam.....	173
ECDS.....	173
IGES.....	173
ManCat.....	173
Metrolog.....	174
NC.....	174
Text.....	174
Text Setup.....	174
VDA.....	173
V-SURF.....	173
V-SURF Setup.....	174
XYZ.....	174
Exposure	
Setting the.....	137

File Alignment	180
File Menu	128
Close	129
Exit	134
Export Data Files	130
New Project.....	128
Open Project	128
Open Template Project.....	128
Print.....	133
Print Preview.....	133
Print Setup	134
Recent Projects	134
Report	132
Report Setup	132
Save	129
Save Image As.....	129
Final Bundle.....	23
Flip Direction	178
Global Delete.....	57
Global Rename.....	57
Graphical Field of View	70
GSI32.INI	
Bundle Bad Criteria	51
Bundle General	46
Bundle Weak Criteria	49
Default Settings.....	46
Highlight Points	60
Icons.....	196
IGES Setup.....	150, 173
Image Path	
Default	9
Manually Setting.....	9
Picture from Disk	10
Setting the	9
Import	172
AutoBar.....	172
Construction.....	172
Data File.....	172
Driver File	172
Offset.....	172
To Design	172
Import Data File.....	14, 149
From Project Menu.....	15
From Right Click on 3D Data Icon.....	16
Import Driver	
From Advanced Edit.....	13
From Project Menu.....	12
From Right Click on Data	13

Import Driver File.....	11
Import Images	9, 150
Import Probes	149
Import the Images into the Project	11
Importing Files.....	9
Include All Images	170
Initial Bundle.....	23, 35
Invert Print.....	69
Invert Save	69
Keyboard Commands	200
Label	
Scale	65
Skip	65
Line to Line	97
Line Width.....	65
Lines	90
Manual Alignment	84, 181
Maximum Iterations	39
Measurement Scale	65
Merge 3D Files	175
Minimum Rays.....	39
MMode Menu.....	155
Moved to Design	176
Nearness Threshold	183
New Data File	171
New Project	1
Offset	178
Open Project	4
Opening an Existing V-STARS Project	4
Paste Points.....	176
Perspective and Orthographic View	70
Picture Menu	159
Close	160
Contrast	161
Delete	161
From Camera.....	159
From Disk.....	159
Next.....	160
Previous.....	160
Quit Review Mode	161
Reset.....	160
Set Label.....	161
Picture View	17
Introduction.....	17
Picture Icons.....	18
Picture Tools	17
Pictures	
Enabled	169

Plan Quality Factor	35
Plane to Line	98
Plane to Plane	95
Planes	88
Offsetting	102
Positive Direction	101
Point Size.....	63
Point to Object.....	99
Project Menu	135
Advanced Edit	136
AutoMatch.....	153
AutoMeasure	145
Bundle	142, 151
Coded Target	143
General Parameters	137
Global Point Edit.....	145
Import.....	136, 148
INCA Camera	142
Label Setup	154
Restore	147
Scale Bars	144
Triangulate	152
Update.....	146
Quick Alignment	71, 81, 180
Rename AutoMatch	185
Rename Points	57
Renumber Pictures.....	170
Reports.....	123
Creating.....	125
Introduction.....	123
Setup.....	123
Template Files	126
Rescan Image Path.....	170
Resect Pictures	170
Residual RMS.....	31
Residual Scale	65
Residuals	
Quick.....	180
Standard.....	180
Right Click	
Cameras Icon.....	168
Created Objects	177
Data Icon	171
Design Points.....	174
Graphical View.....	190
In Picture.....	189
Measured Points.....	176
Measurement objects	179

Multiple 3D Files	175
Picture Thumbnails	188
Pictures Icon.....	169
Points in Design.....	176
Recycle Bin Icon.....	188
ScaleBars Icon	187
Right Click Menus.....	168
Rotation Multiplier	65
Save Epochs	137
Save Images	137
Scale	
Applying	28, 193
Scale Bars	
Adding	26
View	62
Scaling Measurements.....	26
Scanning Parameters	
M-Mode	138
S-Mode	138
Select	193
Close Points.....	193
Constructed	193
Design	194
Highlights	193
Measured	194
Probe.....	194
Probed Points.....	193
Set Image Path.....	5, 170
Setting the color.....	67
SOLIDS.....	87
Circles	91
Construction Objects.....	118
Creating Objects.....	88
Curves.....	94
Introduction.....	87
Line to Line	97
Lines.....	90
Offsetting Planes	102
Plane to Line	98
Plane to Plane	95
Planes.....	88
Point to Curve.....	105
Point to Object	99
Point to Object Projection	103
Spheres	94
Spheres.....	94
Standard Alignment	72, 81, 180
Standard Deviation	

Changing Fields.....	81
Starting a V-STARS Project.....	1
Step Scale.....	63
Strobe.....	137
Sub-Sampling.....	39
SuperStart.....	23
Surfaces.....	106
Commands.....	108
Importing.....	106
Introduction.....	106
Measurement.....	108
Positive Direction.....	111
Projection.....	111
Surfaces in the Project.....	113
Terminology.....	107
Target Criteria.....	139
Target Filters.....	139
Target Nuggets.....	144
Template – Mark a 3D file as.....	187
Template Project.....	6
Creating.....	6
Destination folder.....	8
Introduction.....	6
Opening a.....	7
Title and Window Dimensions.....	69
Tolerance	
Adjusting the Tolerance.....	66
Tolerance Bar.....	63
Tool Tip	
Enable Tool Tip.....	63
Tools Menu.....	166
Customize.....	166
Total Error Propagation.....	39
Total Vector Components.....	60
Transform.....	181
Translation Multiplier.....	65
Triangulation.....	39
Update	
Cameras.....	146, 168
Default System Configuration.....	147
Default Window Settings.....	147
Probes.....	146
Scale Bars.....	146
Update Construction Objects.....	179
Vector.....	86, 192
Construction Objects.....	115
Vectors	
Design Residuals.....	58

Entity Measurements.....	58
Entity Residuals.....	58
View	
AutoBar.....	62
Coordinate Axis.....	61
Design Data.....	58
Labels.....	62
Lighting.....	63
Measured Data.....	58
Normals.....	62
Normals Selected.....	62
Picture Stations.....	62
Probe Data.....	58
Rays.....	62
Scale Bars.....	62
Wireframe.....	63
View Menu.....	162
Construction Bar.....	165
Cursors Bar.....	19, 163
Movement Bar.....	165
Picture Bar.....	18, 162
Show Crosses.....	165
Show Data Window.....	165
Show Labels.....	165
Show Objects.....	165
Show Scan Points.....	165
Show Zoom Window.....	165
Status Bar.....	21, 164
View Bar.....	21, 164
View Setup.....	58
Display Colors.....	69
General.....	58
General (cont.).....	61
Tolerances.....	66
WinTrans.....	183
XYZ Vector Components.....	60
Zipping a Project.....	167