

Energy Industries of Ohio

Contract # S005242-F

Modular Coil Winding Form

C-2 Documentation Package

5/31/2006

This C-2 MCWF Consists of:

Part 1

**Final documentation package
Metal Tek International
Pages 4 – 129
Latest revision – 5-31-06
Foundry documentation**

Part 2

**Final Documentation Package
Major Tool & Machine, Inc.
Pages 130 - 207
Latest Revision – 5-31-06
Machine shop documentation**

Part 3

Metal Tek radiographic films from Part 1 (shipped to PPPL)

Major Tool radiographic films from Part 2 (shipped to PPPL)

Energy Industries of Ohio

Contract # S005242-F

Modular Coil Winding Form

C-2 Documentation Package

5/31/2006

Revisions

3/2/06

- added revised CA-1323 – MTK portion

5/31/06

- added revised weld map & RT photos - MTK portion
- added CA-1320 – MTK portion
- Changed TOC – MTK portion
- Added NC-18830 – MTM portion (page 206)
- Added NC-18830 – MTM portion (page 207)

Energy Industries of Ohio

Contract # S005242-F

Modular Coil Winding Form

C-2 Documentation Package

5/31/2006

**Part 1 – Metal Tek International
Casting Data Package**

C-2 Documentation Package

List of Documents 5-31-2006

Doc #	Description	Page #
4	MTR weighted average of chemistry – 3 ladles replaced by product analysis	6
4a	MTR for Wisconsin Centrifugal	7
5	Chemistry for weld material lot 3012668/82743	8
6	Chemistry of weld material lot # WO19711	9
7	West Moreland Tensile Test Report @ -320°F – 6-17-05	10
8	St Louis Test Lab – 5/17/05 - incl tensile test results at room temp & CVN @ 77°k & 293°k	11
9	Westmoreland tensile test result – weld material@ -320°F – 4-28-05	18
10	St Louis Testing tensile test report weld material @ RT – 4-22-05	19
11	St Louis Testing CVN test report of weld material @ -320°F - 4-6-05	20
12	St Louis Testing CVN test report weld material @ RT 3-2-05 note – pg 2 of report from unrelated project. Included to show pg 2 of 2	22
13	Weld map list – revised 5-31-06	24
13a	RT photos – revised 5-31-06	34
14	Final inspection report	43
15	RT inspection reports from MQS dated 5-20-05 & 6-11-05	44
16	Metal Tek radiographic Interpretation report dated 6-15-05	51
17	Heat treat chart – 4-28-05	52
18	Heat treat chart – stress relief – 6-21-05	53
19	CA-1292 for major welds 6-2-05	54
20	CA-1292a for major welds – 6-15-05	56
21	CA-1302 test material – lack of direction – 5-29-05 & signed 6-6-05	57
21a	CA-1323 for sulfur/phosphorus readings -2-21-06 revision	58
21b	CA-1423 for non conforming Metrode chemistry	63
21c	CA-1320 for lack of test material – inserted into package on 5-31-06	65
22	MQS Radiographic technique sheet – 1-18-05	67
23	C-2 MTS – signed & dated	72
24	Supplemental routing card for C-2 stress relief – 6-21-05	85
25	Qualifying report from dimensional scan C-2 - 5-22-05	86
25a	Qualifying report from dimensional scan C-2 - 5-23-05	94
26	MTR C-2 shim revised - 9-24-05	110
27	Westmoreland shim tensile results @ -320°F	111
28	St Louis Test CVN shim material @ 77°k & 293°k + mechanical test results at RT – 6-13-05	112
29	Final inspection report – C-2 shim dated 6-21-05	115
30	C-2 shim C of C -6-21-05	116
31	CA-1308 – Chemistry out of spec	117
32	Metal Tek radiographic interpretation report C-2 shim – 6-23-05	118
33	Heat treat chart C-2 shim – 6-3-05	120
34	Dimensioned sketch C-2 shim – 6-23-05	121
35	MTS – C-2 shim – dated & signed	123
36	EIO shipping release – 6-27-05	129
5-31-06		



Carondelet Division

8600 Commercial Blvd. - Pevely, MO 63070 USA
Phone: 636-479-4499 - Fax: 636-479-3399

Material Test Report

ENERGY INDUSTRIES OF OHIO

C-2 Doc Package
Document # 4

Replaced by product
analysis - See CA 1323

Purchase Order Number PPPL-FP-LTS-2

Cert Number S75920-1

Pattern Number MCWF-C2

Pour Date 4/15/2005

CAF Metal Designation CF8MNMnMod

Material Spec CF8MNMnMOD

Weighted average of 3 heats - 29060(46%),29061(25%),29063(29%) Total Weight 29107 lbs.

Revised 10/26/05

Element	Min	Actual	Max
C	0.04	0.06	0.07
MN	2.3	2.8	2.8
SI	0.0	0.5	0.7
CR	18.0	18.0	18.5
NI	13.0	13.2	13.5
MO	2.1	2.3	2.5
P*	0.0	0.023	0.035
S*	0.0	0.018	0.025
N	0.24	0.26	0.28

*P & S taken from cast on bar, zones 1,2,&3 and analyzed by wet chemistries, ASTM E1019-03 for sulfur and Colorimetric for phosphorous.

PRODUCT ANALYSIS

Results of spectrometer analysis of cast on test bar after spectrometer preventive maintenance performed and at Wisconsin Centrifugal.

***Not analyzed on spectrograph.

Element	CAF after PM	WC Analysis
C	***	0.07
MN	1.6	1.6
SI	0.8	.09
CR	18.2	18.2
NI	13.5	13.7
MO	2.3	2.2
P	0.024	0.023
S	0.012	0.014
N	***	0.23

Charles A. Ruud
Quality Assurance Manager

Superior Quality Engineered Metal Products

www.MetalTekInt.Com



Carondelet Division

8600 Commercial Blvd. - Pevely, MO 63070 USA
Phone: 636-479-4499 - Fax: 636-479-3399

C-2 Doc Package
Document # 4a

Material Test Report

ENERGY INDUSTRIES OF OHIO

Purchase Order Number PPPL-FP-LTS-2

Pattern Number MCWF-C2

CAF Metal Designation CF8MNMnMod

Material Spec CF8MNMnMOD

Analysis performed by Wisconsin Centrifugal

Cert Number S75920-1

Pour Date 4/15/2005

Revised 11/3/05

Element	Min	Actual	Max
C	0.04	0.07	0.07
MN*	2.3	1.6	2.8
SI*	0.0	0.9	0.7
CR	18.0	18.2	18.5
NI*	13.0	13.7	13.5
MO	2.1	2.2	2.5
P	0.0	0.023	0.035
S	0.0	0.014	0.025
N	0.24	0.23	0.28

* See Corrective Action Number 1323.

Respectfully Submitted,
Charles A. Ruud
Quality Assurance Manager

Superior Quality Engineered Metal Products

www.MetalTekInt.Com

PRODUCT CONFORMANCE REPORT



Product LNM.4455
 Class. EN 12072-99: G 20 16 3 Mn L

Size(s) mm 1,2
 Lot/Batch 3012668/82743
 Item No. 692129

C-2 Doc Package
 Document # 5

Customer CK SUPPLY
 Contact Ernie Simpson
 Eureka (MISSOURI) 63025
 UNITED STATES

Quantity
 Customer ref. P.O.: SL056508
 LSW Order No. SD418352

Chemical analysis (%)

EN10204 3.1B

C	Si	Mn	P	S	Cr	Ni	Mo	Cu	N
0,02	0,4	7,2	0,014	0,003	19,6	15,7	2,7	0,1	0,17

Can't read that high J.G.

Mechanical tests: all weld metal

EN10204

Additional information
 Other tests

EN10204

Remarks

The product identified above has been manufactured, tested and supplied in compliance with a Quality Assurance Programme that fulfils the requirements of EN 29000/ ISO 9000:BS 5750 or similar standard.
 We herewith certify that the product complies with the above-mentioned standards.
 Certified ISO 9001:2000.

Company	Issued by	Function	Date	Cert.No.
Lincoln Smitweld B.V.	P. van Etteger	QS Manager	27/01/2005	3012668/8274
Registered Office Av. des Dukerborghsen 20 6334 AD NELLEKEN	Telephone +31 24 3522931	Fax +31 24 3522500		

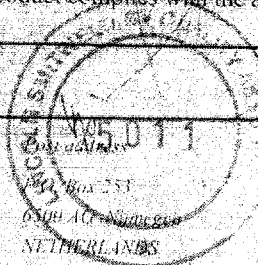

METRODE PRODUCTS LIMITED
HANWORTH LANE, CHERTSEY

**CERTIFIED MATERIAL
TEST REPORT**



SURREY, UK, KT16 9LL

THIS PRODUCT HAS BEEN MANUFACTURED
AND SUPPLIED THROUGH A SYSTEM
APPROVED TO ISO 9001 & 2 OR EQUIVALENT

Tel: +44 (0) 1932 566721

Fax: +44 (0) 1932 565168

Email: info@metrode.com

Website: www.metrode.com



TEST CERTIFICATE NUMBER

175185

INVOICE TO
Euroweld Ltd
255 Rolling Hills Road
Mooresville
NC 28117
USA

DESPATCHED TO
Euroweld Ltd
255 Rolling Hills Road
Mooresville
NC 28117
USA

CUSTOMER ORDER NUMBER	N 03-134
DELIVERY NOTE DOCUMENT NUMBER	DN0096436
QUANTITY (KG)	40.5000
OUR ORDER REFERENCE	SO1777956 / 1
DATE	07/01/04

METRODE WELDING CONSUMABLE	ULTRAMET B316NF 4.0MM
FORM	MMA ELECTRODE
BATCH NUMBER	WO19711
SPECIFICATION	BS EN 1600:1997 E 18 15 3 L B 4 2

Chemical Analysis (Weight %)										Type: BS EN 10204: 3.1.B / ASME SFA-5.01: Sch. H	
C	Mn	Si	S	P	Cr	Ni	Mo	Cu	N		
0.02	3.28	0.24	0.009	0.023	18.0	15.4	2.80	0.07	0.11		

--	--	--	--	--	--	--	--	--	--	--	--

Mechanical Tests						Type: BS EN 10204: 2.2		
Tensile Tests						Impact Energies		
Condition	Test Temperature	Rp0.2% (MPa)	Rm (MPa)	A4 (%)	Z (%)	Temperature (°C)	Impact Energy (J)	Lateral Expansion (mm)
AS-WELDED	ROOM	>420	>600	38	54	-196	>40	

Metrode Products Limited certifies that the above material conforms to the indicated specifications

This document is produced electronically and is valid without signature.

IMPORTANT: Any liability arising from either reliance on this certificate, or use of our products, is strictly limited and governed by our conditions of business

Barrie Kyle - Q.A. Manager

ASME SFA-5.01: Lot classification: C4

Notes:
% Ni includes incidental Co unless otherwise specified
% Nb (Cb) includes incidental Ta unless otherwise specified
Ferrite is given as FN (Ferrite number) and measured on all-weld pad using instrument calibrated against NBS-related secondary standards (See AWS A4.2-97) unless otherwise specified

Westmoreland Mechanical Testing & Research, Inc.
 P.O. Box 388
 Westmoreland Drive
 Youngstown, Pa. 15696-0388 U.S.A.
 Telephone: 724-537-3131 Fax: 724-537-3151
 Website: www.wmtr.com
 WMT&R is a technical leader in the material testing industry.



Section 1 of 1
 WMT&R Report No. 5-29323
 Req. No. 5394

CERTIFICATION

June 17, 2005
 MetalTek International
 The Carondelet Division
 8600 Commercial Blvd.
 I-55 Industrial Park
 Pevely, MO 63070-1528

Attention: Rick Suria
 Subject: All processes, performed upon the material as received, were conducted at WMT&R, Inc. in accordance with the WMT&R Quality Assurance Manual, Rev. 9, dated 4/1/2000.
 The following tests were performed on this order: TENSILE

TENSILE RESULTS: ASTM E21-03a
 SOAK TIME: 5 Minutes
 SPEED OF TESTING: 0.0030 in./in./min., 0.0500 in./min./in.
 MATERIAL: Metaltek CF8NMnMOD

Sample	TestLog Number	Temp. °F	UTS ksi	0.2% YS ksi	Elong %	RA %	Modulus Msi	Codes	Ult Load lbf	0.2% YLD. lbf	Orig. Dia. (in.)	Final Dia. (in.)	4D Orig		4D Final		Machine Number	AUIR
													GL (in.)	GL (in.)	GL (in.)	GL (in.)		
A1 (Z1)	C03040	-320	165.1	95.5	51	37	25.9	---	33210	19210	0.5060	0.4002	2.00	3.02	0.20109020	M9	R	
A1 (Z2)	C03041	-320	165.1	94.6	59	51	25.4	---	33120	18980	0.5054	0.3543	2.00	3.18	0.20081359	M9	R	
A1 (Z3)	C03042	-320	168.7	101.8	58	57	25.2	---	33840	20420	0.5054	0.3305	2.00	3.18	0.20081359	M9	R	
C2 (Z1)	C03043	-320	163.6	94.0	51	41	25.9	D	32840	18880	0.5056	0.3891	2.00	3.03	0.20077240	M9	R	
C2 (Z2)	C03044	-320	162.4	91.7	61	61	25.0	---	32580	18390	0.5054	0.3163	2.00	3.21	0.20081359	M9	R	
C2 (Z3)	C03045	-320	165.5	93.9	61	61	25.7	---	33230	18850	0.5056	0.3163	2.00	3.21	0.20077240	M9	R	

AUIR: A=ACCEPTABLE, U=UNACCEPTABLE, R=REPORT

D - Failed outside middle half of gage length.

Matthew Johnston
 Roy E. Stamm Wojcik
 Technical Services Manager / Tensile Supervisor
 6-17-05
 June 17, 2005

Testing Specialists for Aerospace, Automotive, and Material Testing Fields
 Locations in Youngstown, PA U.S.A. ~ Tel. (724) 537-3131 and
 Banbury U.K. ~ Tel. +44 (0) 1295 261211

KNOWNLY OR WILLFULLY FALSIFYING OR CONCEALING A MATERIAL FACT ON THIS FORM OR MAKING FALSE, FICTITIOUS OR MISLEADING STATEMENTS OR REPRESENTATIONS HEREIN COULD CONSTITUTE A FELONY VIOLATING FEDERAL STATUTES. THE CERTIFICATE OR REPORT SHALL NOT BE REPRODUCED EXCEPT IN FULL WITHOUT THE WRITTEN APPROVAL OF WMT&R, INC.



2810 Clark Avenue • St. Louis, MO 63103-2574 • (314) 531-8080 • FAX (314) 531-8085

METALTEK INTERNATIONAL
 8600 Commercial Blvd.
 Pevely, MO 63070

May 17, 2005
 Lab No. 05P-1488
 P.O. No. 12516
 Page 1 of 7

C-2 Doc Package
 Document # 8

Attention: Chuck Ruud

REPORT OF MECHANICAL TESTS

SAMPLE ID: 3 Ea. C-2 COIL, #Z1, #Z2, & #Z3

Sample ID	Original Area Sq. Inches	Reduced Area Sq. Inches	Reduction in Area %	Yield Strength PSI	Tensile Strength PSI	Elongation (2.0" Gage Length)		Modulus of Elasticity Msi
						in.	%	
#Z1	.1948	.0946	51.4	37,700	82,000	1.17	51.4	23.4
#Z2	.1948	.0887	54.5	35,900	81,000	1.03	51.5	23.2
#Z3	.1901	.0887	53.3	36,100	84,300	1.15	57.5	21.4

Round, reduced section tensiles

Yield taken at .2% offset

Tested in accordance with ASTM A 370

Identification of tested specimens provided by the client



Karl Schmitz, Director
 Materials Testing



Certificate No. 0397-01
 Certificate No. 0397-02

AN OFFICIAL COPY OF TEST REPORT WILL BE PROVIDED BY THIS LABORATORY ON REQUEST. DO NOT REPRODUCE.
 NOT OFFICIAL WITHOUT THE RAISED SEAL OF ST. LOUIS TESTING LABORATORIES, INC.
 SEE REVERSE FOR CONDITIONS.



2810 Clark Avenue • St. Louis, MO 63103-2574 • (314) 531-8080 • FAX (314) 531-8085

METALTEK INTERNATIONAL
 8600 Commercial Blvd.
 Pevely, MO 63070

May 17, 2005
 Lab No. 05P-1488
 P.O. No. 12516
 Page 2 of 7

Attention: Chuck Ruud

C-2 Doc Package
 Document # 8

REPORT OF CHARPY IMPACT TEST

MATERIAL (SAMPLE ID): C-2 COIL, #Z1
SPECIFICATION: ASTM A 370-03a
SPECIMEN TYPE: "A" Vee Notch
SPECIMEN SIZE: 10 mm x 10 mm
TEMPERATURE OF TEST: 293°K

RESULTS:

BASE METAL	FOOT LBS.	LATERAL EXPANSION	% SHEAR
Z1-1	140	.106	100
Z1-2	128	.059	70
Z1-3	150	.126	100
<u>AVERAGE</u>	139	.097	90

Identification of tested specimen provided by client.



Certificate No. 0397-01
 Certificate No. 0397-02

[Signature]
 Karl Schmitz, Director
 Materials Testing

AN OFFICIAL COPY OF TEST REPORT WILL BE PROVIDED BY THIS LABORATORY ON REQUEST. DO NOT REPRODUCE.
 NOT OFFICIAL WITHOUT THE RAISED SEAL OF ST. LOUIS TESTING LABORATORIES, INC.
 SEE REVERSE FOR CONDITIONS.





2810 Clark Avenue • St. Louis, MO 63103-2574 • (314) 531-8080 • FAX (314) 531-8085

METALTEK INTERNATIONAL
 8600 Commercial Blvd.
 Pevely, MO 63070

May 17, 2005
 Lab No. 05P-1488
 P.O. No. 12516
 Page 3 of 7

Attention: Chuck Ruud

C-2 Doc Package
 Document # 8

REPORT OF CHARPY IMPACT TEST

MATERIAL (SAMPLE ID): C-2 COIL, #Z1
SPECIFICATION: ASTM A 370-03a
SPECIMEN TYPE: "A" Vee Notch
SPECIMEN SIZE: 10 mm x 10 mm
TEMPERATURE OF TEST: 77°K

RESULTS:

BASE METAL	FOOT LBS.	LATERAL EXPANSION	% SHEAR
Z1-4	90	.045	60
Z1-5	80	.049	60
Z1-6	81	.055	60
<u>AVERAGE</u>	84	.050	60

Identification of tested specimen provided by client.



Certificate No. 0397-01
 Certificate No. 0397-02

Karl Schmitz
 Karl Schmitz, Director
 Materials Testing

AN OFFICIAL COPY OF TEST REPORT WILL BE PROVIDED BY THIS LABORATORY ON REQUEST. DO NOT REPRODUCE.
 NOT OFFICIAL WITHOUT THE RAISED SEAL OF ST. LOUIS TESTING LABORATORIES, INC.
 SEE REVERSE FOR CONDITIONS.





2810 Clark Avenue • St. Louis, MO 63103-2574 • (314) 531-8080 • FAX (314) 531-8085

METALTEK INTERNATIONAL
 8600 Commercial Blvd.
 Pevely, MO 63070

May 17, 2005
 Lab No. 05P-1488
 P.O. No. 12516
 Page 4 of 7

Attention: Chuck Ruud

C-2 Doc Package
 Document # 8

REPORT OF CHARPY IMPACT TEST

MATERIAL (SAMPLE ID): C-2 COIL, #Z2
SPECIFICATION: ASTM A 370-03a
SPECIMEN TYPE: "A" Vee Notch
SPECIMEN SIZE: 10 mm x 10 mm
TEMPERATURE OF TEST: 293°K

RESULTS:

BASE METAL	FOOT LBS.	LATERAL EXPANSION	% SHEAR
Z2-1	140	.118	100
Z2-2	154	.090	90
Z2-3	150	.109	100
<u>AVERAGE</u>	148	.105	97

Identification of tested specimen provided by client.



Karl Schmitz
 Karl Schmitz, Director
 Materials Testing





2810 Clark Avenue • St. Louis, MO 63103-2574 • (314) 531-8080 • FAX (314) 531-8085

METALTEK INTERNATIONAL
 8600 Commercial Blvd.
 Pevely, MO 63070

May 17, 2005
 Lab No. 05P-1488
 P.O. No. 12516
 Page 5 of 7

Attention: Chuck Ruud

REPORT OF CHARPY IMPACT TEST

C-2 Doc Package
 Document # 8

MATERIAL (SAMPLE ID): C-2 COIL, #Z2
SPECIFICATION: ASTM A 370-03a
SPECIMEN TYPE: "A" Vee Notch
SPECIMEN SIZE: 10 mm x 10 mm
TEMPERATURE OF TEST: 77°K

RESULTS:

BASE METAL	FOOT LBS.	LATERAL EXPANSION	% SHEAR
Z2-4	88	.071	90
Z2-5	76	.037	60
Z2-6	86	.057	70
<u>AVERAGE</u>	83	.055	73

Identification of tested specimen provided by client.



Certificate No. 0397-01
 Certificate No. 0397-02

[Signature]
 Karl Schmitz, Director
 Materials Testing

AN OFFICIAL COPY OF TEST REPORT WILL BE PROVIDED BY THIS LABORATORY ON REQUEST. DO NOT REPRODUCE.
 NOT OFFICIAL WITHOUT THE RAISED SEAL OF ST. LOUIS TESTING LABORATORIES, INC.
 SEE REVERSE FOR CONDITIONS.





2810 Clark Avenue • St. Louis, MO 63103-2574 • (314) 531-8080 • FAX (314) 531-8085

METALTEK INTERNATIONAL
 8600 Commercial Blvd.
 Pevely, MO 63070

May 17, 2005
 Lab No. 05P-1488
 P.O. No. 12516
 Page 6 of 7

Attention: Chuck Ruud

C-2 Doc Package
 Document # 8

REPORT OF CHARPY IMPACT TEST

MATERIAL (SAMPLE ID): C-2 COIL, #Z3
SPECIFICATION: ASTM A 370-03a
SPECIMEN TYPE: "A" Vee Notch
SPECIMEN SIZE: 10 mm x 10 mm
TEMPERATURE OF TEST: 293°K

RESULTS:

BASE METAL	FOOT LBS.	LATERAL EXPANSION	% SHEAR
Z3-1	154	.086	100
Z3-2	200	.061	100
Z3-3	142	.080	90
<u>AVERAGE</u>	165	.076	97

Identification of tested specimen provided by client.



Certificate No. 0397-01
 Certificate No. 0397-02

K. Schmitz
 Karl Schmitz, Director
 Materials Testing

AN OFFICIAL COPY OF TEST REPORT WILL BE PROVIDED BY THIS LABORATORY ON REQUEST. DO NOT REPRODUCE.
 NOT OFFICIAL WITHOUT THE RAISED SEAL OF ST. LOUIS TESTING LABORATORIES, INC.
 SEE REVERSE FOR CONDITIONS.





2810 Clark Avenue • St. Louis, MO 63103-2574 • (314) 531-8080 • FAX (314) 531-8085

METALTEK INTERNATIONAL
 8600 Commercial Blvd.
 Pevely, MO 63070

May 17, 2005
 Lab No. 05P-1488
 P.O. No. 12516
 Page 7 of 7

Attention: Chuck Ruud

C-2 Doc Package
 Document # 8

REPORT OF CHARPY IMPACT TEST

MATERIAL (SAMPLE ID): C-2 COIL, #Z3
SPECIFICATION: ASTM A 370-03a
SPECIMEN TYPE: "A" Vee Notch
SPECIMEN SIZE: 10 mm x 10 mm
TEMPERATURE OF TEST: 77°K

RESULTS:

BASE METAL	FOOT LBS.	LATERAL EXPANSION	% SHEAR
Z3-4	91	.052	80
Z3-5	86	.050	80
Z3-6	81	.061	80
<u>AVERAGE</u>	86	.054	80

Identification of tested specimen provided by client.



Karl Schmitz
 Karl Schmitz, Director
 Materials Testing

AN OFFICIAL COPY OF TEST REPORT WILL BE PROVIDED BY THIS LABORATORY ON REQUEST. DO NOT REPRODUCE.
 NOT OFFICIAL WITHOUT THE RAISED SEAL OF ST. LOUIS TESTING LABORATORIES, INC.
 SEE REVERSE FOR CONDITIONS.



Certificate No. 0397-01
 Certificate No. 0397-02

Westmoreland Mechanical Testing & Research, Inc.
 P.O. Box 388
 Westmoreland Drive
 Youngstown, Pa. 15696-0388 U.S.A.
 Telephone: 724-537-3131 Fax: 724-537-3151
 Website: www.wmtr.com
 WMTR is a technical leader in the material testing industry.



621-01 & 621-02

CERTIFICATION

April 28, 2005

MetalTek International
 The Carondelet Division
 8600 Commercial Blvd.
 I-55 Industrial Park
 Pevely, MO 63070-1528

Section 1 of 1
 WMT&R Report No. 5-26097
 P.O. No. 19386R9
 WMT&R Quote No. QN250563
 Req. No. 4315

Attention: Rick Suria

Subject: All processes, performed upon the material as received, were conducted at WMT&R, Inc. in accordance with the WMT&R Quality Assurance Manual, Rev. 9, dated 4/1/2000. The following tests were performed on this order: TENSILE

TENSILE RESULTS: ASTM E21-03a

Requirements: UTS ksi (Min 95/Max ---) 0.2% YS ksi (Min 72/Max ---) 4D Elong. % (Min 32/Max ---) Modulus Msi (Min 21/Max ---)
 SOAK TIME: 5 Minutes

SPEED OF TESTING: 0.0050 in./in./min., 0.0500 in./min./in.

MATERIAL: 316 S/S

Sample	TestLog Number	Temp. °F	UTS ksi	0.2% YS ksi	Elong %	RA %	Modulus Msi	Ult. Load lbf	0.2% YLD. lbf	Orig. Dia. (in.)	Final Dia. (in.)	4D		Machine Number	DISPOSITION: Acceptable	
												Orig. GL (in.)	Final GL (in.)			Orig. Area (sq. in.)
Bar#1 (Lot#3012668/82743)	B75123	-320	187.7	126.3	33	22	27.1	37740	25394	0.5060	0.4471	2.00	2.65	0.20109020	M9	A
Bar#2 (Batch#W019711)	B75124	-320	166.9	109.5	34	27	26.4	33500	21990	0.5056	0.4315	2.00	2.67	0.20077240	M9	A

AUIR: A=ACCEPTABLE, U=UNACCEPTABLE, R=REPORT

C-2 Doc Package
 Document # 9

D. J. [Signature]

Matthew [Signature]
 Roy E. Starr, Material Testing Supervisor
 Technical Services Manager
 April 28, 2005

Testing Specialists for Aerospace, Automotive, and Material Testing Fields
 Locations in Youngstown, PA U.S.A. ~ Tel. (724) 537-3131 and
 Banbury U.K. ~ Tel. +44 (0) 1295 261211

KNOWINGLY OR WILLFULLY FALSIFYING OR CONCEALING A MATERIAL FACT ON THIS FORM OR MAKING FALSE, FICTITIOUS OR FRAUDULENT STATEMENTS OR REPRESENTATIONS HEREIN COULD CONSTITUTE A FELONY PUNISHABLE UNDER FEDERAL STATUTES. THIS CERTIFICATE OR REPORT SHALL NOT BE REPRODUCED EXCEPT IN FULL, WITHOUT THE WRITTEN APPROVAL OF WMTR, INC.



10
C-2 Doc Package
Document # 10

2810 Clark Avenue • St. Louis, MO 63103-2574 • (314) 531-8080 • FAX (314) 531-8085

METALTEK INTERNATIONAL
8600 Commercial Blvd.
Pevely, MO 63070

April 22, 2005
Lab No. 05P-1170
P.O. No. 12516
Page 1 of 1
(revised 6/15/05)

Attention: **Chuck Ruud**

REPORT OF MECHANICAL TESTS

SAMPLE ID: 1 Ea., Sample Bar #1, Lot 3012668/82743
1 Ea., Sample Bar #2, Batch # WO19711

Sample ID	Original Area Sq. Inches	Reduced Area Sq. Inches	Reduction in Area %	Yield Strength PSI	Tensile Strength PSI	Elongation (2.0" Gage Length)		Elastic Modulus
						in.	%	
#1	.1901	.0855	55.0	56,500	85,000	0.80	55.0	25.5 MSI
#2	.1917	.0881	54.0	63,900	98,100	0.88	54.0	23.1 MSI

Round, reduced section all weld room temperature tensiles

Yield taken at .2% offset

Tested in accordance with ASTM A 370
Identification of tested specimens provided by the client

KS/tw

Karl Schmitz, Director
Materials Testing



Certificate No. 0597-01
Certificate No. 0597-02

AN OFFICIAL COPY OF TEST REPORT WILL BE PROVIDED BY THIS LABORATORY ON REQUEST. DO NOT REPRODUCE.
NOT OFFICIAL WITHOUT THE RAISED SEAL OF ST. LOUIS TESTING LABORATORIES, INC.
SEE REVERSE FOR CONDITIONS.





C-2 Doc
Package
Document # 11

2810 Clark Avenue • St. Louis, MO 63103-2574 • (314) 531-8080 • FAX (314) 531-8085

METALTEK INTERNATIONAL
8600 Commercial Blvd.
Pevely, MO 63070

April 6, 2005
Lab No. 05P-1007
P.O. No. 12516
Page 1 of 2

Attention: **Chuck Ruud**

REPORT OF CHARPY IMPACT TEST

MATERIAL (SAMPLE ID): 1 Ea., Material (1) LNM4455, Lot # 3012668/82743

SPECIFICATION: ASTM A 370-03a

SPECIMEN TYPE: "A" Vee Notch

SPECIMEN SIZE: 10 mm x 10 mm

TEMPERATURE OF TEST: -320°F

ALL WELD METAL	FOOT LBS.	LATERAL EXPANSION	% SHEAR
LNM4455-1	52	0.027	40
LNM4455-2	50	0.022	40
LNM4455-3	50	0.016	20
Average	51	0.022	33

Identification of tested specimen provided by client.

KS/tw

Karl Schmitz
Karl Schmitz, Director
Materials Testing



Certificate No. 0347-01
Certificate No. 0357-02

AN OFFICIAL COPY OF TEST REPORT WILL BE PROVIDED BY THIS LABORATORY ON REQUEST, DO NOT REPRODUCE.
NOT OFFICIAL WITHOUT THE RAISED SEAL OF ST. LOUIS TESTING LABORATORIES, INC.
SEE REVERSE FOR CONDITIONS.





2810 Clark Avenue • St. Louis, MO 63103-2574 • (314) 531-8080 • FAX (314) 531-8085

C-2 Doc Package
Document # 11

METALTEK INTERNATIONAL
8600 Commercial Blvd.
Pevely, MO 63070

April 6, 2005
Lab No. 05P-1007
P.O. No. 12516
Page 2 of 2

Attention: Chuck Ruud

REPORT OF CHARPY IMPACT TEST

MATERIAL (SAMPLE ID): (2) Metrode B316NF, Batch # WO19711
SPECIFICATION: ASTM A 370-03a
SPECIMEN TYPE: "A" Vee Notch
SPECIMEN SIZE: 10 mm x 10 mm
TEMPERATURE OF TEST: -320°F

ALL WELD METAL	FOOT LBS.	LATERAL EXPANSION	% SHEAR
B316NF-1	48	0.030	30
B316NF-2	52	0.027	30
B316NF-3	44	0.027	30
Average	48	0.028	30

Identification of tested specimen provided by client.

KS/tw

Karl Schmitz, Director
Materials Testing



AN OFFICIAL COPY OF TEST REPORT WILL BE PROVIDED BY THIS LABORATORY ON REQUEST. DO NOT REPRODUCE.
NOT OFFICIAL WITHOUT THE RAISED SEAL OF ST. LOUIS TESTING LABORATORIES, INC.
SEE REVERSE FOR CONDITIONS.



12



2810 Clark Avenue • St. Louis, MO 63103-2574 • (314) 531-8080 • FAX (314) 531-8085

METALTEK INTERNATIONAL
8600 Commercial Blvd.
Pevely, MO 63070

C-2 Doc Package
Document # 12

February 28, 2005
Lab No. 05P-0554
P.O. No. 12516
Page 1 of 2
(Revised Report 3-2-05)

Attention: Rick Suria

REPORT OF CHARPY IMPACT TEST

MATERIAL (SAMPLE ID): Electrode LNM 4455 & B316NF *30126682743*

SPECIFICATION: ASTM A 370-03a *L W01974*

SPECIMEN TYPE: "A" Vee Notch, All Weld *Chk 6/14/05*

SPECIMEN SIZE: 10 mm x 10 mm

TEMPERATURE OF TEST: +70°F

RESULTS:

ALL WELD	JOULES	FOOT LBS.	LATERAL EXPANSION	% SHEAR
LNM 4455-7	149	110	0.055	50
LNM 4455-8	130	96	0.050	50
LNM 4455-9	134	99	0.051	50
Average	138	102	0.052	50
ALL WELD	JOULES	FOOT LBS.	LATERAL EXPANSION	% SHEAR
B316NF-7	155	114	0.056	50
B316NF-8	151	111	0.053	50
B316NF-9	146	108	0.052	50
Average	151	111	0.054	50

Identification of tested specimen provided by client.

KS/clm

[Signature]
Karl Schmitz, Director
Materials Testing



Certificate No. 0397-01
Certificate No. 0397-02

AN OFFICIAL COPY OF TEST REPORT WILL BE PROVIDED BY THIS LABORATORY ON REQUEST. DO NOT REPRODUCE.
NOT OFFICIAL WITHOUT THE RAISED SEAL OF ST. LOUIS TESTING LABORATORIES, INC.
SEE REVERSE FOR CONDITIONS.





2810 Clark Avenue • St. Louis, MO 63103-2574 • (314) 531-8080 • FAX (314) 531-8085

METALTEK INTERNATIONAL
 8600 Commercial Blvd.
 Pevely, MO 63070

C-2 Doc Package
 Document # 12
 (unrelated to C-2)

February 28, 2005
 Lab No. 05P-0554
 P.O. No. 12516
 Page 2 of 2
 (Revised Report 3-2-05)

Attention: Rick Suria

PROCEDURE QUALIFICATION

WELDER: TERRY STANFIELD
MATERIAL: 1" CF8MnMn, Mod
SPECIFICATION: ASME IX
ELECTRODE: B316NF
PROCESS: SMAW

*This is unrelated
 to report for C-2
 Cfr*

REDUCED SECTION TENSILE

SAMPLE ID	WIDTH INCHES	THICKNESS INCHES	AREA SQ. INCHES	ACTUAL LBS.	TENSILE STRENGTH PSI	FRACTURE
TS-2	.750	1.000	.7500	70,000	93,300	Weld Metal
TS-5	.750	1.010	.7575	71,000	93,700	Weld Metal

GUIDED BEND TEST

SAMPLE ID	BEND	RESULTS
TS-1	Side	Acceptable, No Discontinuities
TS-3	Side	Acceptable, No Discontinuities
TS-4	Side	Acceptable, No Discontinuities
TS-6	Side	Acceptable, No Discontinuities

KS/clm

[Signature]
 Karl Schmitz, Director
 Materials Testing
 CWI No. 92120161



Certificate No. 0387-01
 Certificate No. 0397-02

AN OFFICIAL COPY OF TEST REPORT WILL BE PROVIDED BY THIS LABORATORY ON REQUEST. DO NOT REPRODUCE. NOT OFFICIAL WITHOUT THE RAISED SEAL OF ST. LOUIS TESTING LABORATORIES, INC. SEE REVERSE FOR CONDITIONS.



C-2 COIL WELD MAP

Defect Number	Photo Number	Length Inches	Width Inches	Depth Inches	Over 10% Wall Yes/No	Weld Permeability Result
1	11	2 1/2	1 3/4	1/2	No	Acceptable
2	11	1 1/2	3/4	1/8	No	
3	23	2 3/4	1 1/4	3/8	No	
4	23	2	1 1/2	1/4	No	
5	23	2 7/8	1 1/4	3/8	No	
6	23	3/4	1/2	3/8	No	
7	23	7	1 1/2	3/8	No	
8	23	2 1/4	1 1/2	5/8	No	
9	23	2 3/4	1 1/4	1/4	No	
10	23	3 1/2	1 1/4	1/4	No	
11	23	1 3/4	1	3/8	No	
12	24	4	3	1/2	No	
13	24	13 1/2	3 3/4	1/2	Yes	
14	24	2 1/2	1 1/2	1/8	No	
15	16	2 3/4	1	1/4	No	
16	16	2 1/2	1 1/2	3/4	No	
17	16	4	2 1/2	1/2	No	
18	16	2	2	1	Yes	
19	16	1 1/2	3/4	3/4	No	
20	16	2	1 1/4	1	Yes	
21	16	6	4	1 1/4	Yes	
22	14	2 3/4	2	2/8	Yes	
23	14	3 1/2	2 7/8	1/4	No	
24	14	2 1/2	1 3/4	1/4	No	
25	14	5	1	5/8	No	
26	19	2	1 5/8	1/2	No	
27	19	1 3/4	1 1/2	1/4	No	
28	19	6	5	1/4	No	
29	29	2	2	1/4	No	
30	29	4 7/8	3 3/4	1/4	No	
31	29	7	4	7/8	Yes	
32	29	2 1/4	2	1/4	No	
33	29	2	1	1/4	No	

C-2 COIL WELD MAP

Defect Number	Photo Number	Length Inches	Width Inches	Depth Inches	Over 10% Wall Yes/No	Weld Permeability Result
34	15	2	1 1/4	1/4	No	Acceptable
35	15	2 1/2	2	1/4	No	
36	15	2	1	1/8	No	
37	15	1 1/2	1	1/8	No	
38	15	2	1 1/2	3/8	No	
39	15	4 1/2	2	1/4	No	
40	15	2 1/2	1 1/2	3/8	No	
41	15	3	1 1/2	1/4	No	
42	15	3 1/2	2 1/2	1/4	No	
43	20	3 1/4	3	1/2	No	
44	20	2 1/2	3/4	1/2	No	
45	20	3 1/4	1	1/4	No	
46	18	8 3/4	2	1/4	No	
47	18	8	2 1/2	1/4	Yes	
48	16	6	3	1/4	No	
49	16	2	1 1/2	1/4	No	
50	16	4	2	1/4	No	
51	46	2 1/2	2	1/8	No	
52	16	3 1/2	2 1/2	1	Yes	
53	46	4 1/2	4	1	Yes	
54	46	1	1	1/4	No	
55	46	6 3/4	2 1/2	1/2	Yes	
56	46	1	1	1/4	No	
57	46	1 1/2	1	1/4	No	
58	46	3 1/2	2	1/8	No	
59	46	6 3/4	1	1/8	No	
60	45	1 1/2	1 1/2	3/4	Yes	
61	45	4 1/2	3 1/2	1/4	No	
62	45	20	5	1	Yes	
63	45	13	4	3	Yes	
64	14	3/4	1/2	1/8	No	
65	16	2 1/2	2	1/4	No	
66	16	3/4	1/2	1/8	No	

C-2 COIL WELD MAP

Defect Number	Photo Number	Length Inches	Width Inches	Depth Inches	Over 10% Wall Yes/No	Weld Permeability Result
67	45	10 1/2	4 1/4	2	Yes	Acceptable
68	14	3/4	1/2	1/8	No	↓
69	14	4 1/2	3	1/4	No	
70	14	3	1 1/2	1/4	No	
71	14	3	1	1/2	Yes	
72	45	1	1	1/4	No	
73	45	1 1/4	1/4	1/8	No	
74	47	1 1/2	1 1/2	3/4	Yes	
75	47	3/4	3/4	1/8	No	
76	47	2	1/2	3/16	No	
77	47	3 4	2 1/2	1/2	Yes	
78	47	1	1/2	1/4	No	
79	47	2 1/2	2	1/4	No	
80	47	7	3	3/8	Yes	
81	19	2 1/2	2	1/4	No	
82	47	1 1/2	1 1/2	1/4	No	
83	47	4	2 1/2	5/8	No	
84	19	2	1/2	1/4	No	
85	19	1 1/2	1	3/4	No	
86	19	7 1/2	5	3	Yes	
87	19	3 1/2	2	1/4	No	
88	19	4	2 1/2	5/8	No	
89	19	3 1/2	3	1/2	Yes	
90	19	2 1/2	2	1/4	No	
91	19	2	3/4	1/4	No	
92	19	9	4	1	Yes	
93	19	1 1/2	1	1/4	No	
94	19	4	3	1/4	No	
95	19	4 1/8	4	1/4	No	
96	19	6	3	1/4	No	
97	19	3	2 1/2	3/4	Yes	
98	19	2 1/2	1	3/4	Yes	
99	25	4	4	1 1/4	Yes	
100	25	2 1/2	2 1/2	1/2	No	
101	25	2 1/2	2 1/2	1 1/2	Yes	

C-2 COIL WELD MAP

Defect Number	Photo Number	Length Inches	Width Inches	Depth Inches	Over 10% Wall Yes/No	Weld Permeability Result	
102	25	2 1/2	2 1/2	1/2	Yes	Acceptable	
103	36	2	1	1/4	No		
104	36	2 1/2	6	1	Yes		
105	36	3	2	1/4	No		
106	29	2 1/2	1 1/2	3/4	Yes		
107	29	1	1	1/4	No		
108	29	3/4	3/4	1/8	No		
109	29	6	3	1	Yes		
110	17	1	1	1/8	No		
111	17	8	5	1	Yes		
112	17	7	4	1	Yes		
113	Deleted	-	-	-	-		-
114	17	2 1/2	2	1	Yes		
115	17	3 1/2	7/8	3/4	Yes		
116	17	5	3	3/4	Yes		
117	17	1 1/2	1 1/2	1/4	No		
118	17	2 1/2	1 3/4	1/4	No		
119	17	10	5	1	Yes		
120	Deleted	-	-	-	-		-
121	17	1	1/2	1/2	Yes		
122	17	10	2 1/2	1 3/4	Yes		
123	17	2 1/2	2	1/4	No		
124	17	2	1 1/2	1/2	Yes		
125	17	3	2 3/4	1	Yes		
126	15	4 1/2	3 1/2	3/4	Yes		
127	15	1 1/2	1	1/4	No		
128	15	4	2 1/2	1/4	No		
129	15	2	1 1/2	1/4	No		
130	15	2	1	1/4	No		
131	15	2	1/2	1/4	No		
132	31	1 1/2	1	1/4	No		
133	31	2 1/2	1	1/2	Yes		
134	31	3	1	1/2	Yes		
135	31	2 1/2	2	1/2	Yes		
136	31	2	1	1/4	No		
137	31	1	1	1/4	No		
138	31	2	1	1/4	No	✓	

C-2 COIL WELD MAP

Defect Number	Photo Number	Length Inches	Width Inches	Depth Inches	Over 10% Wall Yes/No	Weld Permeability Result
139	31	7	5 1/2	1/2	Yes	Acceptable
140	31	2	1	1/4	No	
141	31	5	2	1/2	Yes	
142	31	2 1/2	2	1/4	No	
143	19	5	2 3/4	1/8	No	
144	19	5	2 1/2	1/4	No	
145	19	1 1/2	1	1/8	No	
146	19	3	2 1/2	1/4	No	
147	19	3	2 1/2	1/4	No	
148	34	12	3	1	Yes	
149	82	1 1/2	1	1/4	No	
150	41	3	2	1/8	No	
151	22	6	2	1/8	No	
152	22	1 1/2	1 1/2	1	Yes	
153	24	3	1 1/2	1/8	No	
154	24	2 3/4	1	1/8	No	
155	44	3	1 1/2	1	Yes	
156	42	2	1	1/4	No	
157	42	2	1	1/2	Yes	
158	42	2	1	1/4	No	
159	42	3	2 3/4	1 1/2	Yes	
160	42	3	2	5/8	Yes	
161	42	6	2	1	Yes	
162	42	4 1/2	1	3/4	Yes	
163	42	1	1/2	1/2	Yes	
164	42	2 1/2	1	1/8	No	
165	42	2	1 1/4	1/4	No	
166	42	3	2	1/4	No	
167	42	1 1/2	1	1/8	No	
168	42	3	2	1/8	No	
169	42	13	2	1 3/4	Yes	
170	42	2	1	1/2	Yes	
171	42	2	1	1/8	No	
172	42	2 1/2	1 3/4	1/4	No	
173	42	2	1	1/8	No	
174	42	2	1	1/8	No	
175	23	3	2 1/2	1/8	No	

C-2 COIL WELD MAP

Defect Number	Photo Number	Length Inches	Width Inches	Depth Inches	Over 10% Wall Yes/No	Weld Permeability Result
176	23	2	1	1/8	no	Acceptable
177	23	2	1	1/8	no	
178	8	3	1 3/4	1/4	no	
179	8	2	1	1/8	no	
180	8	3 1/2	2	1/4	no	
181	8	3	1/4	1/8	no	
182	8	4	2	1/4	no	
183	8	3	2	1/2	yes	
184	6	1	1	1/4	no	
185	6	2 3/4	1	1	yes	
186	6	1	1	1/4	no	
187	3	2	1	1/4	no	
188	3	3 1/2	2	1/4	no	
189	21	3	2	1/4	no	
190	8	2 1/2	2	1/4	no	
191	8	2 1/2	1	3/4	yes	
192	8	4	3	1/2	yes	
193	8	8	1 1/2	1	yes	
194	8	19	2	1/2	yes	
195	8	2 3/4	2	1/2	yes	
196	26	6	1 3/4	2	yes	
197	26	1 1/2	1	1/2	yes	
198	26	3	2	1/4	no	
199	26	2	1 1/4	1/4	no	
200	26	4	3	1/4	no	
201	8	1 1/2	1	1/2	yes	
202	8	7 3/4	2	1	yes	
203	8	6 3/4	1 1/2	1/2	yes	
204	8	3	2	1/2	yes	
205	6	2	1 1/4	1/4	no	
206	4	4	2	1/4	no	
207	6	2	1 1/2	1/4	no	
208	6	1	1	1/4	no	

C-2 COIL WELD MAP

Defect Number	Photo Number	Length Inches	Width Inches	Depth Inches	Over 10% Wall Yes/No	Weld Permeability Result
209	26	3 1/2	1 1/2	1	Yes	Acceptable
210	26	1	3/4	1/4	No	1
211	Deleted	—	—	—	—	—
212	26	4	2 1/2	1/4	No	}
213	28	6	2 1/2	3/4	Yes	
214	28	4	2	3/4	Yes	
215	Deleted	—	—	—	—	
216	3	3 1/2	1	3/4	Yes	}
217	28	2	2	1	Yes	
218	28	2	1	3/4	Yes	
219	28	2	1	1/4	No	
220	1 ^{cut} _{flow}	3	1	1	Yes	
221	3	5	4	1/4	No	
222	3	4	1	1/4	No	
223	3	13	4	1/2	Yes	
224	3	2	1	1/4	No	
225	9	9 1/2	7	1/2	Yes	
226	9	3	1 3/4	1/2	Yes	
227	9	1 1/2	1	1/4	No	
228	9	1 1/2	1	1/4	No	
229	4	2 1/2	1	1	Yes	
230	11	6	2	1 1/2	Yes	
231	11	7	1 1/2	3/4	Yes	
232	11	3	1 1/4	3/4	Yes	
233	11	3	1 1/4	3/4	Yes	
234	11	3	2	1/8	No	
235	11	1 1/2	3/4	1/4	No	
236	11	1	3/4	1/8	No	
237	11	2	3/4	1/4	No	
238	11	2	1	1/4	No	
239	11	1 3/4	1	1/4	No	
240	11	8 1/8	3 3/4	1/4	Yes	
241	2	3	1/4	1/8	No	
242	2	1/2	1/2	1/8	No	
243	2	1 1/2	1 1/2	1/4	No	✓

C-2 COIL WELD MAP

Defect Number	Photo Number	Length Inches	Width Inches	Depth Inches	Over 10% Wall Yes/No	Weld Permeability Result
244	2	1/2	1/2	1/4	No	Acceptable
245	2	6	1	3/4	Yes	1
246	2	9	2	1/4	Yes	
247	46	8 3/8	3 3/4	1/2	Yes	
248	46	1	1	1/2	No	
249	46	1	1	1/2	No	
250	46	1	1	1/2	No	
251	45	5 1/2	1 1/2	1/8	No	
252	45	2 1/2	2 1/4	1/4	No	
253	45	9	4 1/2	1/2	Yes	
254	46	13	2 1/4	1/2	Yes	
255	46	1	1	1/8	No	
256	46	1	1	1/8	No	
257	46	1 1/2	1	1/8	No	
258	46	1	1/2	1/8	No	
259	46	4	1	1/8	No	
260	46	1 1/2	1	1/4	No	
261	46	6 1/2	5 1/2	1/2	Yes	
262	46	2 1/2	1	1/4	No	
263	46	8	2 3/8	3/4	Yes	
264	46	10	4 1/4	1/2	Yes	
265	46	2 1/2	1 1/2	1/2	No	
266	46	2 1/2	1 1/2	1/2	No	
267	46	2 1/4	1	1/4	No	
268	46	6 1/2	4 1/2	1	Yes	
269	46	6 1/2	3 3/4	3/4	Yes	
270	38	13 1/2	3 3/4	3/4	Yes	
271	38	7	3/4	1/2	No	
272	18	9	2	1/2	No	
273	38	7	2 1/2	1/2	No	
274	38	17	1	3/4	Yes	
275	38	9 3/4	3/4	3/4	Yes	
276	38	4	4	3/4	Yes	
277	40	14	2 1/4	1 1/2	Yes	
278	40	2	1	1/4	No	
279	40	2	1 1/2	1/4	No	
280	40	2 1/4	1 1/2	1/4	No	↓

C-2 COIL WELD MAP

Defect Number	Photo Number	Length Inches	Width Inches	Depth Inches	Over 10% Wall Yes/No	Weld Permeability Result	
281	37	6 1/2	3/4	3/4	Yes	Acceptable ↓	
282	37	4	3/4	1/4	No		
283	37	1	1/4	1/8	No		
284	17	3	2	1/8	No		
285	17	2	1	1/4	No		
286	17	3	2 1/2	1/4	No		
287	17	4	2	1/4	No		
288	17	4	2 1/2	1/4	No		
289	29	14	5	1/2	No		
290	29	13	5 1/2	1	Yes		
291	29	1 1/2	1	1/8	No		
292	29	11 1/2	8 3/8	1	Yes		
293	29	3/4	1/2	1/8	No		
294	29	5 1/2	4 1/2	3/4	Yes		
295	34	4 1/2	3 1/4	7/8	Yes		

C-2 Weld Map - Use for photos on map # 29 & higher welds are located near black RT # in photo								
Defect #	RT #	New Photo #	Defect #	RT #	New Photo #	Defect #	RT #	New Photo #
29	30	3	150	115	a-1	138	88	19
30	30	3	155	117	a-1	139	88	19
31	30	3	156	36	7	140	88	19
32	30	3	157	36	7	141	87	19
33	30	3	158	36	7	142	87	19
51	12	24	159	36	7	148	85	15
53	13	24	160	39	21	268	62	16
54	13	24	161	39	21	269	62	16
55	13	24	162	39	21	270	71	8
56	12	24	163	97	7	271	71	8
57	12	24	164	97	7	273	83	a-2
58	12	24	165	37	7	274	71	8
59	14	22	166	36	7	275	72	8
60	16	11	167	35	7	276	72	8
61	16	11	168	35	7	277	74	a-2
62	16	11	169	35	7	278	75	13
63	16	11	170	39	21	279	75	13
67	58	14	171	39	21	280	75	13
72	17	11	172	38	21	281	82	a-2
73	17	11	173	38	21	282	76	13
74	18	12	174	38	21	283	77	a-3
75	18	12	247	14	22	289	30	3
76	18	12	248	14	22	290	30	3
77	18	12	249	14	22	291	30	3
78	18	12	250	14	22	292	29	3
79	19	9	251	64	16	293	29	3
80	61	14	252	64	16	294	29	3
82	19	9	253	64	16	295	92	a-4
83	19	9	254	63	16			
103	26	21	255	63	16			
104	26	21	256	63	16			
105	26	21	257	63	16			
106	28	7	258	63	16			
107	28	7	259	63	16			
108	28	7	260	63	16			
109	28	7	261	63	16			
132	90	14	262	63	16			
133	90	14	263	63	16			
134	89	19	264	63	16			
135	89	19	265	63	16			
136	89	19	266	62	16			
137	88	19	267	62	16			



1



2



3



4

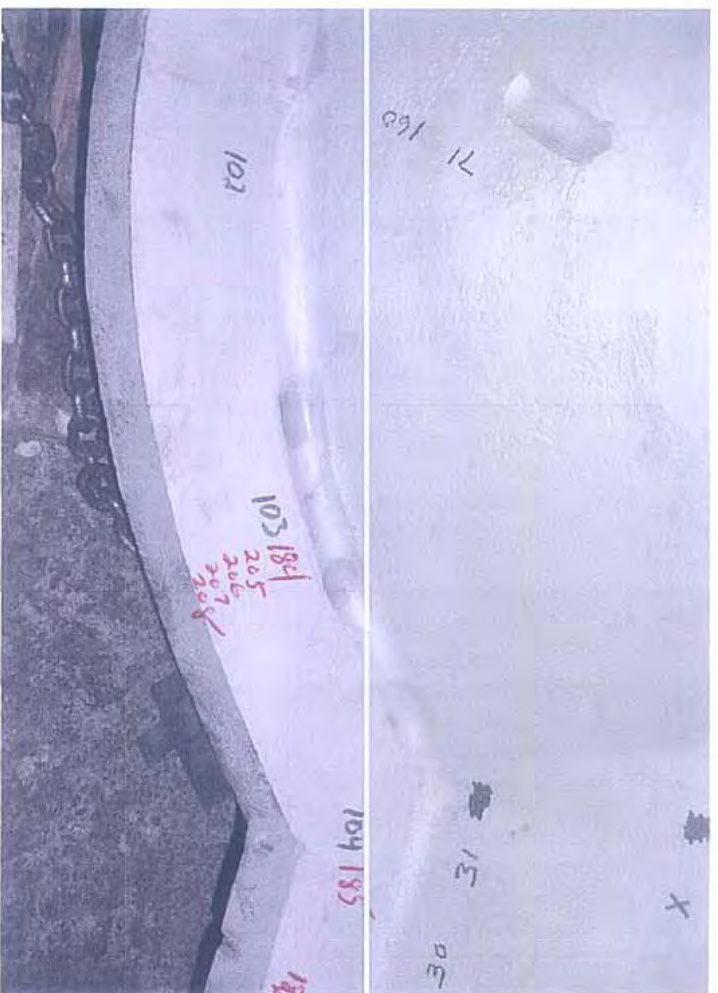

1

8

10

4

35

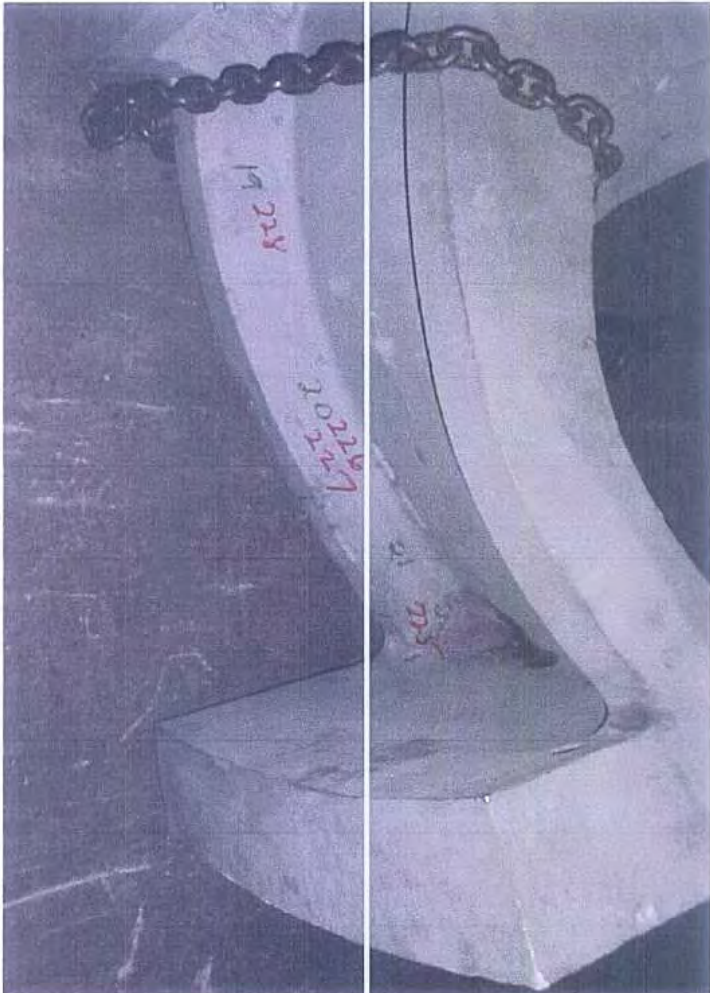

9



10

36



11



12

15



13



16



14



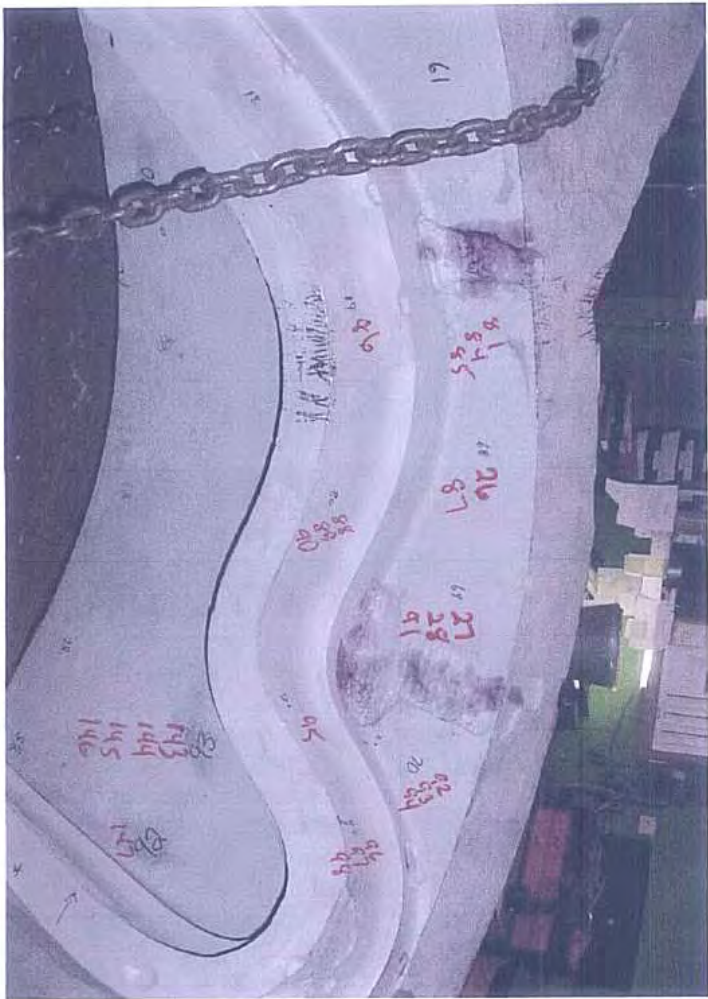

19



17

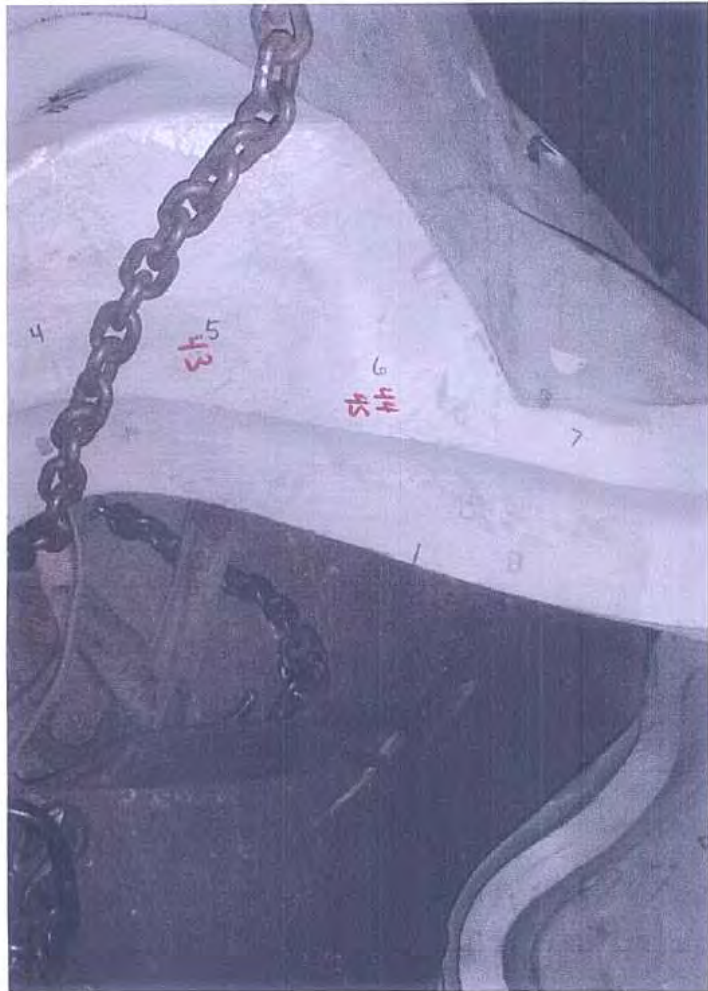

20



18

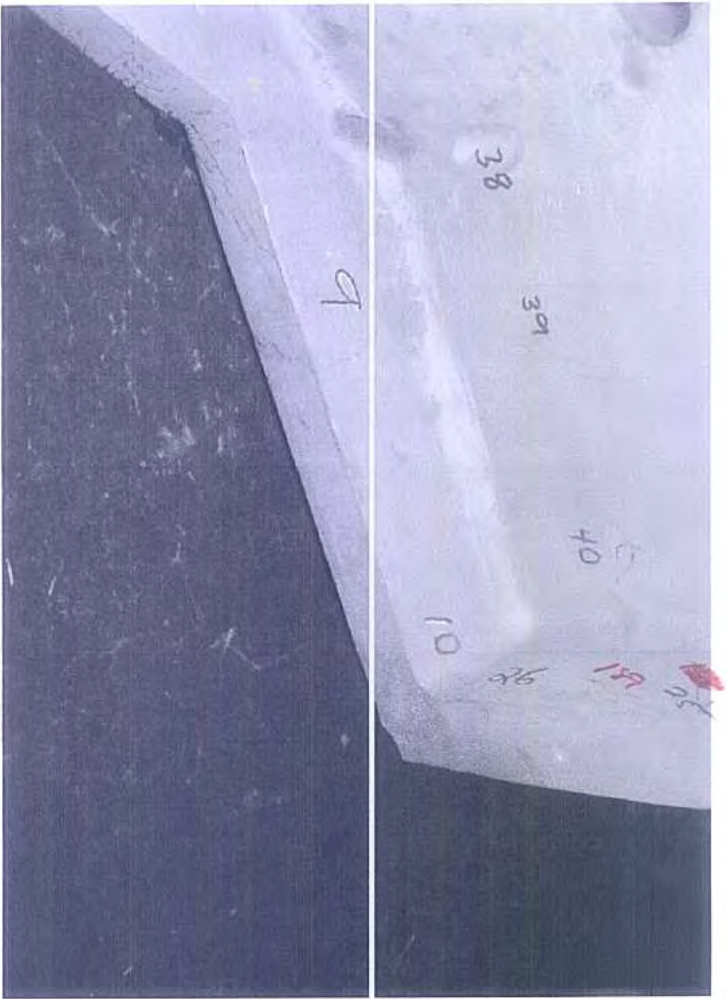

21

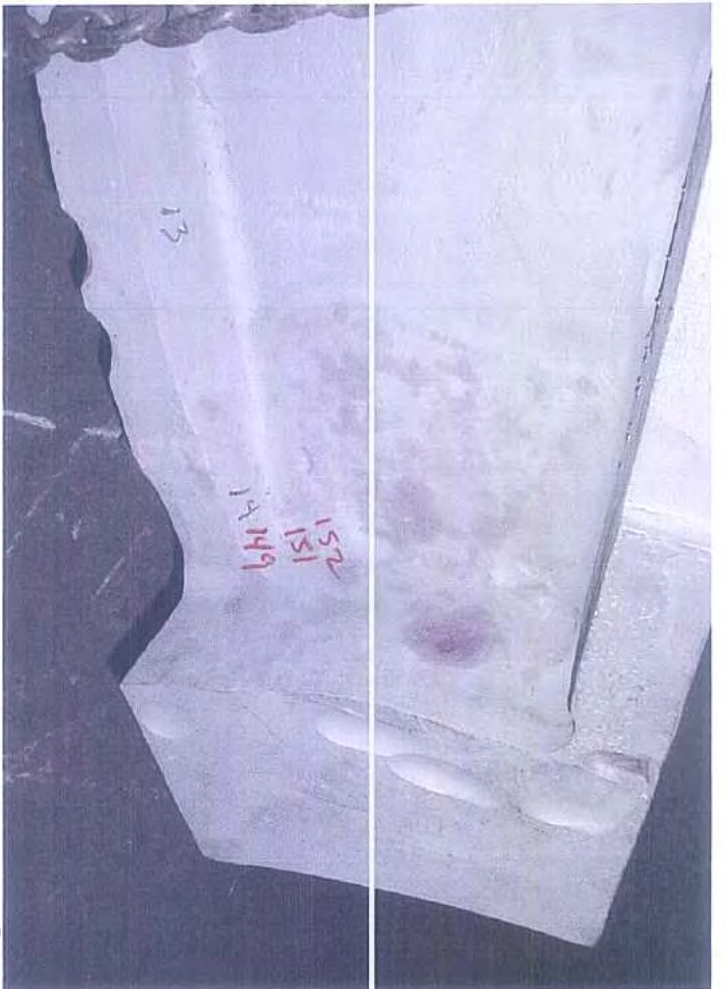

22

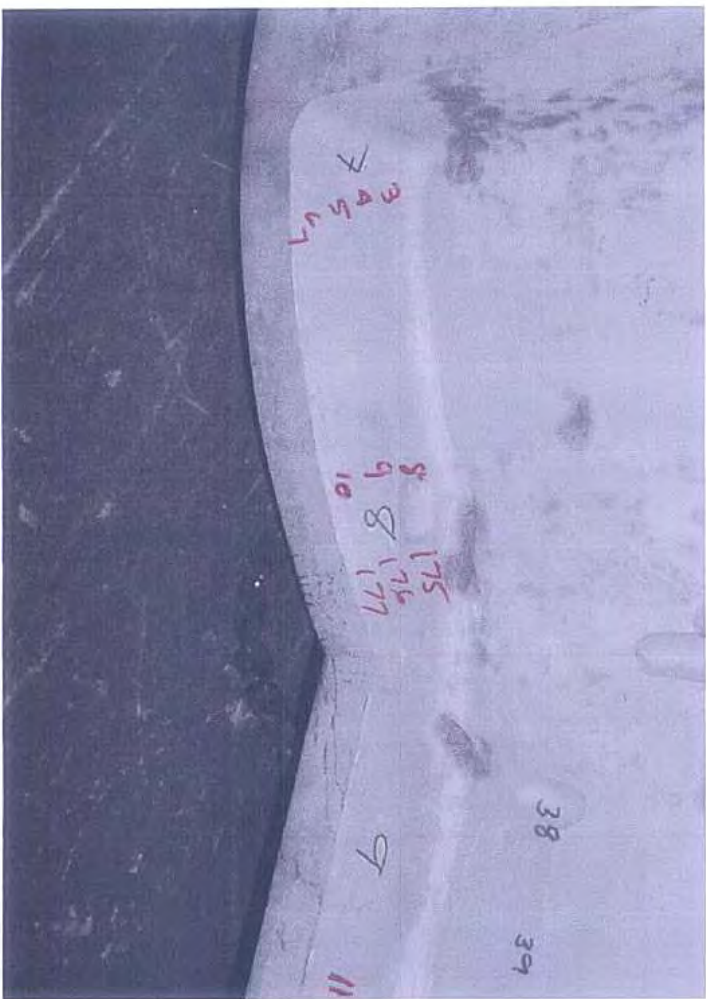

23



24

39

27



25



28



26

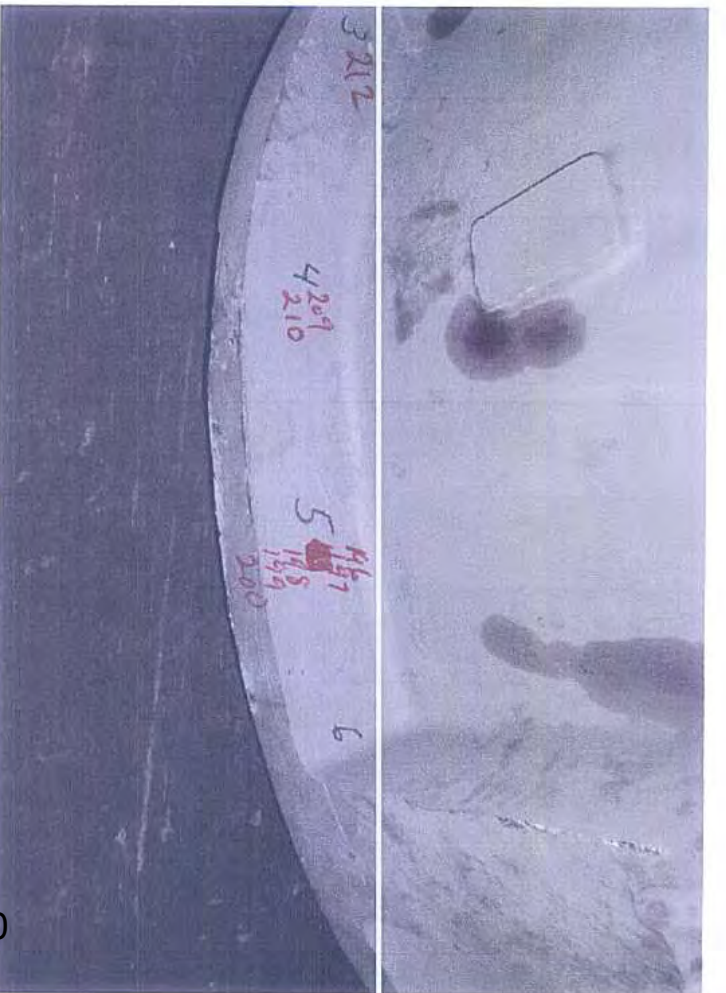

40

C-2 Weld Map – Supplemental photos



Supplemental photo A-1



Supplemental Photo A-2

C-2 Weld Map – Supplemental photos



Supplemental Photo A-3



Supplemental Photo A-4



14

C-2 Doc Package
Document # 14

Carondelet Division

8600 Commercial Blvd. - Pevely, MO 63070 USA
Phone: 636-479-4499 - Fax: 636-479-3399

Final Inspection Report

Customer Name: ENERGY INDUSTRIES OF OHIO

Pattern: MCWF-C2

Order Number: PPPL-FP-LTS-2

Revised 7/26/05

ASTM Metal CF8MNMN MOD

Date 7/26/2005

Type Description	Cert Number	Procedure	Acceptance Criteria	Actual
Liquid Penetrant	S75920-1	CQP - 300 Rev 9	SEE NOTE	Acceptable
Notes Acceptance per ASTM A903. Acceptance criteria - level 1 for high stressed areas, level 2 for all other areas.				
Mag Perm	S75920-1	SOP Mag Perm 100 Rev 1	<1.02	Acceptable
Radiographic	S75920-1	Technique # 12726	MSS SP 54	Acceptable
Visual	S75920-1	CQP - 500 REV 4	ASTM A802 LEVEL 2	Acceptable

Liquid Penetrant

Technician: Jason Rees
ASNT Level II

Respectfully Submitted,
Charles A. Ruud
Quality Assurance Manager

TEAM COOPERHEAT-MQS, INC.

CERTIFIED RADIOGRAPHIC INSPECTION REPORT

FORM 6061-RT- 002 Rev.2

5512 W. State St. Milwaukee, WI 53208 Tel:(414)771-3060 Fax:(414)771-9481 (800)818-6403 www.cooperheat-mqs.com

CUSTOMER

NAME METAL TEK INTERNATIONAL
 ADDRESS 8600 COMMERCIAL BLVD
 CITY PEVELY STATE MO ZIP 63070

DATE 05/20/2005

WORK ORDER NO. 361-02283

P.O. NUMBER 21041

XRAY X
 GAMMA

PROCEDURE SPECIFICATION ASTM E94-93

ACCEPTANCE CRITERIA MSS-SP-54-1999

SHEET OF

PART NUMBER	Serial No	View	No Apparent Indications		Incomplete Penetration		Shrinkage		Film Artifacts		REMARKS
			Acceptable	Rejection	Dross or Slag	Porosity	Lack of Fusion Gas Cracks	Hot Tears	Under cut	Surface	
MCWF -C2	1	1-2	✓		2						
MAIN BODY		2-3	✓								
E.I.O. C040851		3-4	✓				1				
		4-5	✓								
MS75920		5-6	✓								
		7-8	✓								
		8-9	✓								
	9	9-10	✓	1st R		2					
		11-12	✓		2					R-2 ✓ 3+	
		12-13	✓								
		13-14	✓		1						
		14-15	✓								
		15-16	✓			1					
		16-17	✓		1						
		17-18	✓								
		18-19	✓								
		19-20	✓								
		20-21	✓		2						
		21-22	✓		1						
		23-24	✓		1						
		24-25	✓								
		26-27	✓				2				
		27-28	✓								
		29-30	✓		1						
		30-31	✓		1						

NO. ACCEPTED NO. REJECTED 1

MQS TECH. NO. 12970 SHT. REV.

CUST. RSS NO. SHT. REV.

REVIEWER [Signature] S. TOWLE
 CERTIFIED NOT LEVEL (RT) II

C-2 Doc Package
 Document # 15

TEAM COOPERHEAT-MQS, INC.

CERTIFIED RADIOGRAPHIC INSPECTION REPORT

FORM 6061-RT- 002 Rev.2

5512 W. State St. Milwaukee, WI 53208 Tel:(414)771-3060 Fax:(414)771-9481 (800)818-6403 www.cooperheat-mqs.com

CUSTOMER

NAME METAL TEK INTERNATIONAL
 ADDRESS 8600 COMMERCIAL BLVD
 CITY PEVELY STATE MO ZIP 63070

DATE 05/20/2005

WORK ORDER NO.
361-02283

P.O. NUMBER
21041

XRAY X

GAMMA

PROCEDURE SPECIFICATION
ASTM E94-93

ACCEPTANCE CRITERIA
MSS-SP-54-1999

SHEET OF

PART NUMBER	Serial No	View	No Apparent Indications		Incomplete Penetration		Shrinkage		Film Artifacts		REMARKS
			Acceptable	Rejection	Dross or Slag	Porosity	Lack of Fusion Gas Cracks	Hot Tears	Under cut	Surface	
MCWF -C2	1	32-33	✓		2						
MAIN BODY		33-34	✓							✓	
E.I.O. C040851		35-36	✓		2					✓	
		36-37	✓							✓	
MS75920		38-39	✓							✓	
		39-40	✓		2					✓	
		41-42	✓							✓	
		42-43			R					✓	
		44-45	✓					R		✓	
		45-46			R					✓	
		47-48			R			R		✓	
		48-49			R			R(2)		✓	
		49-50-51	✓		R			R(2)		✓	
		52-53	✓							✓	
		53-54	✓							✓	
		54-55	✓							✓	
		55-56	✓							✓	
		56-57	✓							✓	
		57-58	✓							✓	
		58-59	✓							✓	
		59-60	✓							✓	
		60-61	✓							✓	
		62-63	✓							✓	
		63-64	✓							✓	
		65-66	✓							✓	

NO. ACCEPTED 6

NO. REJECTED 1

MQS TECH. NO. 12970

SHT. REV.

CUST. RSS NO.

SHT. REV.

C-2 Doc Package
Document # 15

REVIEWER [Signature]
CERTIFIED NOT LEVEL (RT)

S. TERA LO
II

TEAM COOPERHEAT-MQS, INC.

CERTIFIED RADIOGRAPHIC INSPECTION REPORT

FORM 6061-RT- 002 Rev.2

5512 W. State St. Milwaukee, WI 53208 Tel:(414)771-3060 Fax:(414)771-9481 (800)818-6403 www.cooperheat-mqs.com

CUSTOMER

NAME METAL TEK INTERNATIONAL
 ADDRESS 8600 COMMERCIAL BLVD
 CITY PEVELY STATE MO ZIP 63070

DATE 05/20/2005

WORK ORDER NO. 361-02283

P.O. NUMBER 21041

XRAY X
 GAMMA

PROCEDURE SPECIFICATION ASTM E94-93

ACCEPTANCE CRITERIA MSS-SP-54-1999

SHEET OF

PART NUMBER	Serial No	View	No Apparent Indications		Dross		Incomplete Penetration		Shrinkage		Film Artifacts		REMARKS
			Acceptable	Rejected	Inclusion	or Porosity	Lack of Fusion	Gas Cracks	Hot Tears	Under cut	Surface		
MCWF -C2	1	67-68	✓										
MAIN BODY		68-69	✓										
E.I.O. C040851		69-70	✓										
		V64	✓										
MS75920		71-72	✓		1								
		72-73	✓										
		73-74	✓										
		74-75	✓										
		75-76	✓										
		76-77	✓										
		78-79	✓		1								
		79-80	✓										
		80-81	✓										
		81-82	✓										
		83-84	✓										
		85-86	✓		2								
		86-87	✓		1								
		87-88	✓	R									
		88-89	✓										
		90-91	✓		1								
		92-93	✓	R									
		V94	✓						2 R				
		V95	✓						1				
		96-97	✓										
		97-98	✓	R									

NO. ACCEPTED 0

NO. REJECTED 1

MQS TECH. NO. 12970

SHT. REV.

COMMENTS
 C-2 Doc Package Document # 15

CUST. RSS NO.

SHT. REV.

REVIEWER [Signature]
 CERTIFIED NDT LEVEL (RT) J. TERALB

TEAM COOPERHEAT-MQS, INC.

CERTIFIED RADIOGRAPHIC INSPECTION REPORT

FORM 6061-RT- 002 Rev.2

5512 W. State St. Milwaukee, WI 53208 Tel:(414)771-3060 Fax:(414)771-9481 (800)818-6403 www.cooperheat-mqs.com

CUSTOMER

NAME METAL TEK INTERNATIONAL
 ADDRESS 8600 COMMERCIAL BLVD
 CITY PEVELY STATE MO ZIP 63070

DATE 05/20/2005

WORK ORDER NO.
361-02283

P.O. NUMBER
21041

XRAY X
GAMMA

PROCEDURE SPECIFICATION
ASTM E94-93

ACCEPTANCE CRITERIA
MSS-SP-54-1999

SHEET OF

PART NUMBER	Serial No	View	No Apparent Indications		Incomplete Penetration		Shrinkage		Film Artifacts		REMARKS
			Acceptable	Rejection	Inclusion or Slag	Porosity	Lack of Fusion Gas Cracks	Hot Tears	Under cut	Surface	
MCWF -C2	1	98-99	✓		R						
MAIN BODY		100-101	✓		R						
E.I.O. C040851		102-102	✓								
		102-103	✓								
MS75920 P		103-104			R						
		104-105			R			R			
		105-107			R			R			
		107-108	✓					R			
		108-109	✓								
		109-110	✓								
		111-112	✓		1						
		112-113	✓			2					
		114-115	✓								
		115-116	✓					2			
		116-117			R			R			

NO. ACCEPTED 11 NO. REJECTED 1

MQS TECH. NO. 12970 SHT. REV.
 CUST. RSS NO. SHT. REV.

REVIEWER [Signature] S. T. G. 5/20/05
 CERTIFIED LEVEL (RT) [Signature]

C-2 Doc Package
Document # 15

TEAM COOPERHEAT-MQS, INC.

CERTIFIED RADIOGRAPHIC INSPECTION REPORT

FORM 6061-RT- 002 Rev.2

5512 W. State St. Milwaukee, WI 53208 Tel:(414)771-3060 Fax:(414)771-9481 (800)818-6403 www.cooperheat-mqs.com

CUSTOMER

NAME METAL TEK INTERNATIONAL
 ADDRESS 8600 COMMERCIAL BLVD
 CITY PEVELY STATE MO ZIP 63070

DATE 05/20/2005

WORK ORDER NO.
361-02283

P.O. NUMBER
21041

XRAY X

GAMMA

PROCEDURE SPECIFICATION
ASTM E94-93

ACCEPTANCE CRITERIA
MSS-SP-54-1999

SHEET _____ OF _____

PART NUMBER	Serial No	View	No Apparent Indications		Dross or Porosity		Incomplete Penetration		Shrinkage			Film Artifacts		REMARKS
			Acceptable	Rejection	Included	or Porosity	Lack of Fusion	Gas Cracks	Hot Tears	Under cut	Surface			
MCWF -C2	1	1-2	✓				1							
INSIDE RAIL		2-3	✓				1							
E.I.O. C040851		3-4	✓				1							
		4-5	✓				1							
MS75920		5-6	✓											
		6-7	✓											
		7-8	✓											
		8-9	✓											
		9-10	✓											
		10-11	✓											
		11-12	✓											
		12-13	✓		1									
		13-14	✓											
		14-15	✓				1							
		15-16	✓											
		16-17	✓		1		2-3							
		17-18	✓				1							
		18-19	✓											
		19-20	✓		2									
		20-21	✓											
		21-22	✓						1-2					
		22-23	✓						1					
		23-24	✓											
		24-25	✓											
		25-26	✓											

NO. ACCEPTED 1 NO. REJECTED 0

MQS TECH. NO. 12970 SHT. REV.

CUST. RSS NO. REV.

C-2 Doc Package
Document # 15

REVIEWER S. TERRELL
CERTIFIED NOT LEVEL (RT)

TEAM COOPERHEAT-MQS, INC.

CERTIFIED RADIOGRAPHIC INSPECTION REPORT

FORM 6061-RT- 002 Rev.2

5512 W. State St. Milwaukee, WI 53208 Tel:(414)771-3060 Fax:(414)771-9481 (800)818-6403 www.cooperheat-mqs.com

CUSTOMER

NAME METAL TEK INTERNATIONAL
 ADDRESS 8600 COMMERCIAL BLVD
 CITY PEVELY STATE MO ZIP 63070

DATE 05/20/2005

WORK ORDER NO.
361-02283

P.O. NUMBER
21041

XRAY X
GAMMA

PROCEDURE SPECIFICATION
ASTM E94-93

ACCEPTANCE CRITERIA
MSS-SP-54-1999

SHEET _____ OF _____

PART NUMBER	Serial No	View	No Apparent Indications		Dross or Porosity		Incomplete Penetration		Shrinkage		Film Artifacts		REMARKS
			Acceptable	Rejected	Inclusion	or Porosity	Lack of Fusion	Gas Cracks	Hot Tears	Under cut	Surface		
MCWF -C2	1	26-27	✓		1								
INSIDE RAIL		V28	✓									✓	
E.I.O. C040851		29-30	✓		1							✓	
		30-1	✓									✓	
MS75920												✓	

NO. ACCEPTED 1 NO. REJECTED 0 MQS TECH. NO. 12970 SHT. REV.

C-2 Doc Package
Document # 15

CUST. RSS NO. REVIEWER S. TERALES SHT. REV.
 CERTIFIED NDT LEVEL (RT) JL

TEAM COOPERHEAT-MQS, INC.

CERTIFIED RADIOGRAPHIC INSPECTION REPORT

FORM 6061-RT- 002 Rev.2

5512 W. State St. Milwaukee, WI 53208 Tel:(414)771-3060 Fax:(414)771-9481 (800)818-6403 www.cooperheat-mqs.com

CUSTOMER

NAME METAL TEK INTERNATIONAL
 ADDRESS 8600 COMMERCIAL BLVD
 CITY PEVELY STATE MO ZIP 63070

DATE 06/11/2005

WORK ORDER NO.
361-02341

P.O. NUMBER
21041

XRAY X
GAMMA

PROCEDURE SPECIFICATION
ASTM E94-93

ACCEPTANCE CRITERIA
MSS-SP-54-1999

SHEET 1 OF 1

PART NUMBER	Serial No	View	No Apparent Indications		Incomplete Penetration			Shrinkage			Film Artifacts			REMARKS
			Acceptable	Rejected	Dross or Slag	Porosity	Lack of Fusion	Gas Cracks	Hot Tears	Under cut	Surface			
MCWF -C2	1	9-10	✓		2									
		41-42	✓		1				1					✓
E.I.O. C040851		45-46	✓		1					2				
		47-48	✓		1					1				
MS75920		48-49	✓											
(R1)		87-88	✓											✓
		92-93		R				R						✓
		97-98	✓						1					
		103-104	✓											
		104-105	✓											
		106-107	✓		1									
		116-117	✓		1									

NO. ACCEPTED 0 NO. REJECTED 1 MQS TECH. NO. 12970 SHT. REV.
 COMMENTS CUST. RSS NO. SHT. REV.
 REVIEWER John Petroske
 CERTIFIED NOT LEVEL (RT)
 John Petroske RT II Exp. 01/08

C-2 Doc Package
Document # 15

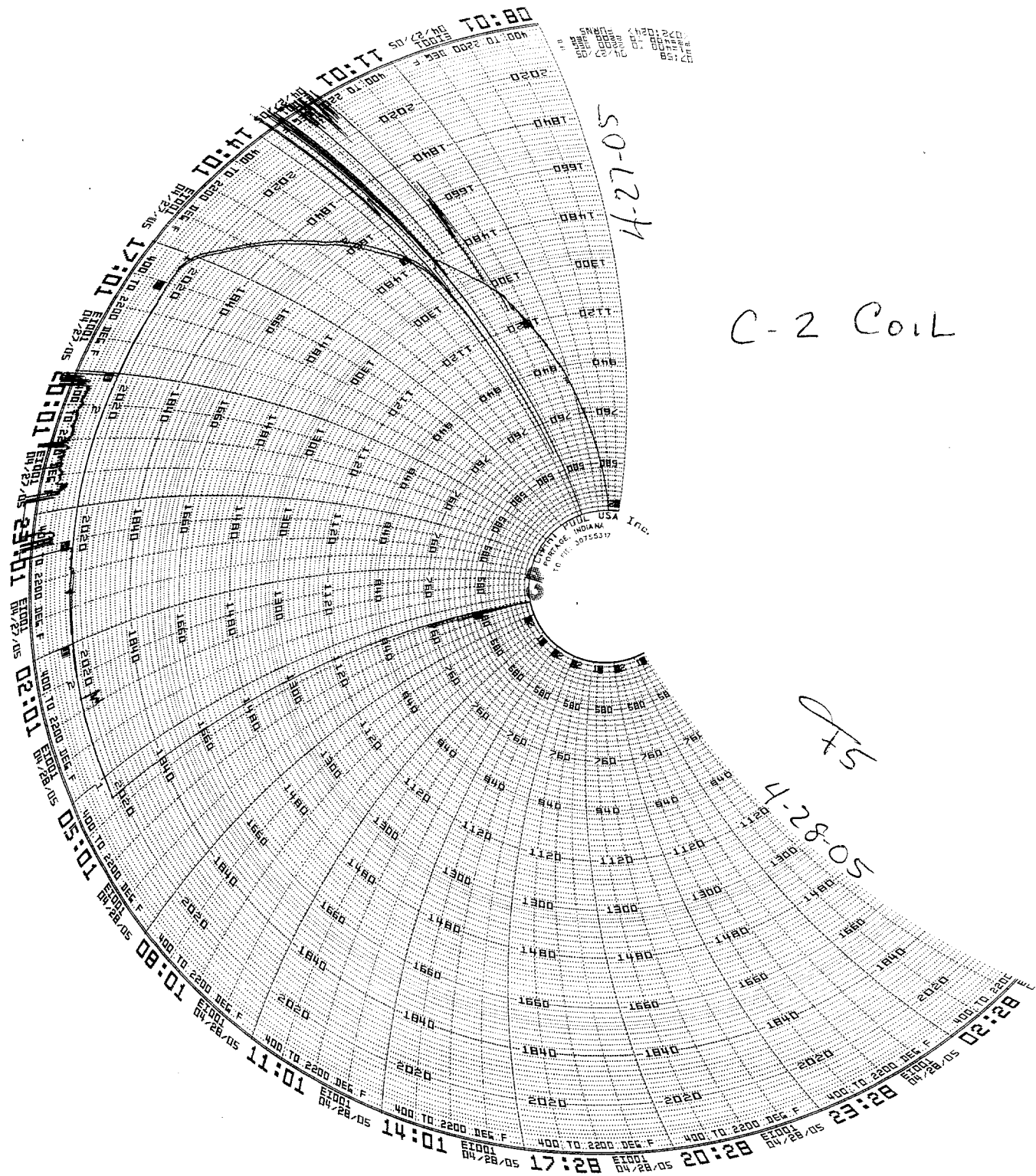

C-2 Coil
5 Pass
Relief
6/21/05

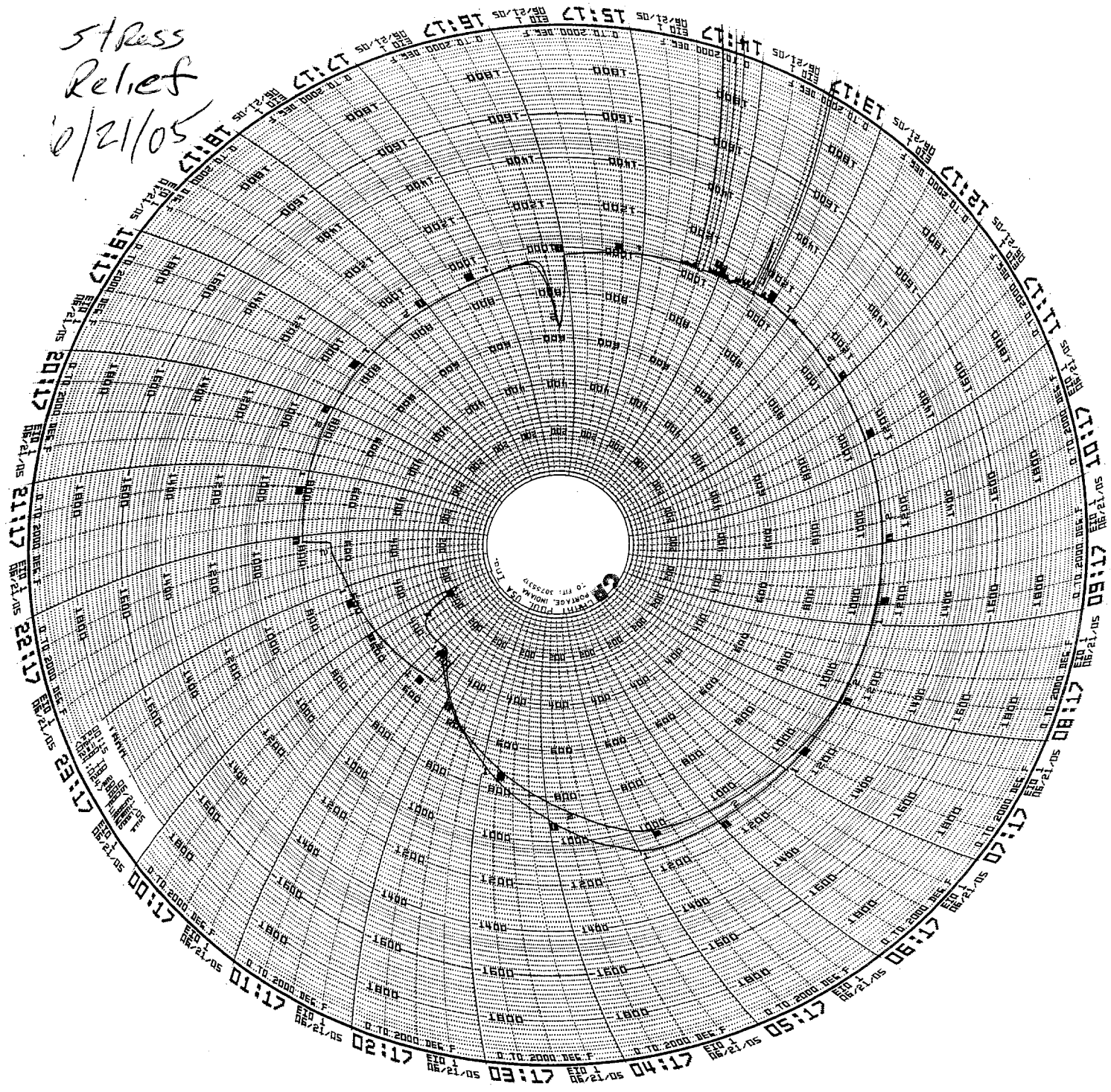

Corrective Action 1292
Carondelet Division - CA / PA / RGA Database
Corrective Action Type NCR
Date 6/1/2005 6-2-05 Rev *I chr*
CA Originator C. Ruud
Pattern Number: C-2 Coil

C-2 Doc
Doc 19

Description of Defect / Non-Conformance

104 defects requiring major welds were found during visual, LP and RT inspections.

Root Cause

Inherent to the manufacturing process.

Corrective Action Weld upgrade C1 casting. Welding will be performed following the approved procedure FOR WELDS <2" - WPS 10-SMAW-CF8MNMN MOD REV 1. FOR WELDS <8" - WPS 15-GMAW-CF8MNMN MOD REV 2.

Verification of Corrective Action

All repairs will be verified by the inspection method used to discover the original defect.



Signed: C. Ruud

CC: Roger Broman, Barry Craig, Joe Edwards, E.J. Kubick

Nonconformance Report: MetalTek CA 1292 Rev. 1

C-2 Doc
Doc 19

Project Disposition: Corrective action approved

Approvals

Procurement Technical Representative

Wayne Reiersen

Digitally signed by Wayne Reiersen
DN: cn=Wayne Reiersen, c=US, o=PPPL
Reason: I am approving this document
Date: 2005.06.16 15:33:32 -0400

Wayne Reiersen for Phil Heitzenroeder

Responsible Line Manager

MJC for B. E. Nelson

Digitally signed by MJC for B. E. Nelson
DN: cn=MJC for B. E. Nelson, o=US, ou=Fuison Energy Div,
ou=PEO, email=mjc@mfc.gov
Date: 2005.06.16 16:51:22 -0400

Mike Cole for Brad Nelson

Corrective Action 1292a
Carondelet Division - CA / PA / RGA Database
Corrective Action Type NCR
Date 6/15/2005
CA Originator C. Ruud
Pattern Number: C -2 Coil

C-2 Doc
Doc 20

Description of Defect / Non-Conformance

Defect found during RT verification. Result in a major weld.

Root Cause

Lack of fusion was discovered.

Corrective Action

Weld repair will be made according to approved procedures.

Verification of Corrective Action

Area will be LP and RT inspected.

Estimated Completion Date

6/15/05

Actual Completion Date

Complete.



Signed: C. Ruud

CC: Roger Broman, Barry Craig, Joe Edwards, E.J. Kubick

We concur with this CA.

Phil Heitzenroeder

2005.06.23 08:55:36 -04'00'

Brad Nelson

Document Control System
© 2005 MetalTek International, Inc. All rights reserved.
EHS 00000000-0000-0000-0000-00000000



Corrective Action 1302
Carondelet Division - CA / PA / RGA Database
Corrective Action Type NCR
Date 5/29/2005
CA Originator C. Ruud
Pattern Number: C-2 Coil

C-2 Doc Package
Document # 21

Description of Defect / Non-Conformance

Failed to differentiate two directions of test material on pattern/casting per the requirement of NCSX-CSPEC-141-03-07, SECTION 4.2.2.

Root Cause

Failed to communicate specification to Pattern Shop to add cast on test material specimens in the transverse direction.

Corrective Action

Will request a deviation to eliminate requirement.

Verification of Corrective Action

N/A

Preventive Action

Create Inspection and Test Plan summarizing all requirements.

Estimated Completion Date

6/15/05

Actual Completion Date

Signed: C. Ruud

CC: Roger Broman, Barry Craig, Joe Edwards, E.J. Kubick

Accept As-Is. NCSX-CSPEC-141-03-07
is being revised to eliminate the requirement
to test in 2 directions. 6-6-05 pta
Ref. also 1301. 57

Nonconformance Report: CA 1323 (phosphorus levels exceeds specification limits for castings C1- C4 and A1 and C1 shim and four Type C and six A coil shims)

Project Disposition:

The erroneous levels were due to calibration errors with the spectrometer. As reported in MTK's attached report, preventive maintenance has since been performed on the spectrometer. The reported chemistry will be accepted for the castings and shims noted above. The specification chemistry will not be changed at this time.

Approvals:

**Phil
Heitzenroeder**

Digitally signed by Phil Heitzenroeder
DN: CN = Phil Heitzenroeder, C = US,
O = PPPL, OU = Mech. Eng. Division
Reason: I agree to 'specified' portions
of this document
Date: 2006.02.21 11:49:56 -05'00'

Procurement Technical Representative

**Brad
Nelson**

Digitally signed by Brad Nelson
DN: cn=Brad Nelson, c=US,
o=ORNL, ou=FED,
email=nelsonbe@ornl.gov
Date: 2006.02.21 14:16:12
-05'00'

Responsible Line Manager:



Corrective Action 1323
Carondelet Division - CA / PA / RGA Database
Corrective Action Type NCR
Date 7/27/2005
CA Originator C. Ruud
Applies to: Coil castings C-1, C-2, C-3, C-4 and A-1 and C 1 shim and four C coil and six A coil shims

Description of Defect / Non-Conformance

Phosphorus levels in material produced to date exceed specification limits. Both phosphorus and sulfur readings reported erroneously in certifications.

Certification reports have shown phosphorus and sulfur levels in the <.01% range. Independent laboratory data confirmed phosphorus in the .018 to .033% range and sulfur in the .005 to .022% range. Actual levels of some tests are above those in PPPL Specification NCSX-CSPEC-141-03-07 Rev 7.

Nonconformance was first suspected as a result of analysis of zoned attached test specimens volunteered by MetalTek International as response to PPPL questions on weighted average chemical analysis and quality of blending in the gating system. Nonconformance was verified on the bars used in the study and has been extended to evaluation of previously poured products.

Root Cause

Specification limits were set below the levels achievable through use of available raw materials. Spectrometer did not properly calibrate for phosphorus and sulfur at levels of specification due to equipment malfunction.

The chemical specification of EIO heats uses alloy CF8MNMn-Mod which incorporates a type standard calibration with a certified reference material (CRM) BS180. This enables the operator of the spectrometer to match the elemental concentrations of this alloy with corrective factors. These factors are determined by analyzing the CRM and having them compared with the calibration curves for each element. The phosphorus and sulfur content have very low measured intensities due to low concentrations. Intermittent failure of the spectrometer intensity measuring card caused higher intensity readings for phosphorus and sulfur. Subsequent checks with the CRM resulted in low corrective factors that were not detected. This in turn resulted in low reported concentrations for the EIO samples. All the major elements, which are measured on other intensity cards, have been closely monitored and matched very well with the CRM and thus were reported correctly.

Corrective Action

Modification to specification for phosphorus and sulfur will be requested. Limits will be set based on process capability and consistent with other stainless steel grades. Replacement of deficient card in spectrometer will be made upon delivery.

Subsequent immediate analysis of chemistry results, obtained by wet analysis, is attached and demonstrate top of specification for sulfur and over specification for phosphorus. The spectrometer manufacturer has performed an analysis to determine the cause of the malfunction and verified that the intensity card has an intermittent fault and must be replaced. The card has been ordered and scheduled for replacement on August 15, 2005.

Until the card is replaced we will be performing additional type standardizations to ensure accurate sulfur and phosphorus analysis. Additionally, for coils made until the card is replaced, an independent laboratory will perform a verification of the chemical analysis.

Verification of Corrective Action

Will be determined at a later date.

Preventive Action

In addition to spectrometer faults, we have identified that the specification ranges for sulfur and phosphorus is unattainable. Analysis and specifications for virgin charge materials predict sulfur at 0.040% maximum and phosphorus at 0.040% maximum. We have no way to remove phosphorus from the melt and do not intentionally add phosphorus. So, the confirmed coil analyses, along with analyses of virgin material heats, demonstrate sulfur in the range of 0.010% to 0.022% and phosphorus in the range of 0.018% to 0.033%. These results are consistent with our charge material analysis. We will request a deviation for phosphorus in the subject parts and also request a permanent specification change to 0.040% maximum for both phosphorus and sulfur, to allow us to provide non-discrepant material. This change will not affect, in any way, the physical properties or material performance because all coils and test material exhibited sulfur and phosphorus within the new ranges despite inaccurate reporting. Other actions: Specifications have been added to the BS 180 standard and the type standard will be measured against the criteria.

Estimated Completion Date

August 15, 2005

Actual Completion Date TBD

Signed: C. Ruud



CC: Jim Galaske, Barry Craig, Joe Edwards, E.J. Kubick

Guide to St Louis Testing Report Dated 7-26-05

Sample name	Sample origin
A1Z1	Cast on bar A-1 coil, zone 1
A1Z2	Cast on bar A-1 coil, zone 2
A1Z3	Cast on bar A-1 coil, zone 3
C1	Cast on bar C-1 coil
C2Z1	Cast on bar C-2 coil, zone 1
C2Z2	Cast on bar C-2 coil, zone 2
C2Z3	Cast on bar C-2 coil, zone 3
C3Z1	Cast on bar C-3 coil, zone 1
C3Z2	Cast on bar C-3 coil, zone 2
C3Z3	Cast on bar C-3 coil, zone 3
F1	Final analysis button from ladle for C-4 coil
F2	Final analysis button from ladle for C-4 coil
F3	Final analysis button from ladle for C-4 coil
P1	Preliminary analysis button from ladle for C-4 coil

Testing is underway of the heat used to pour the four C coil and six A coil shims.

*Attachment to
CA 1323*



Chemical, Metallurgical, Mechanical, Nondestructive, Environmental Testing, Analyses and Field Service.

July 26, 2005
Lab No. 05C-0608
Invoice No. 59891
P.O. No. 21324
Page 1 of 1

METALTEK INTERNATIONAL
8600 Commercial Blvd.
Pevely, MO 63070

Attention: Chuck Ruud

REPORT OF CHEMICAL ANALYSIS

SAMPLE ID: A1 Z1, A1 Z2, A1 Z3, C1, C2 Z1, C2 Z2, C2 Z3,
C3 Z1, C3 Z2, C3 Z3, F1, F2, F3, P1

RESULTS: %

ANALYTE	A1Z1	A1Z2	A1Z3
Sulfur	.013	.005	.010
Phosphorus	.025	.023	.018

ANALYTE	C1	C2Z1	C2Z2	C2Z3
Sulfur	.014	.022	.018	.015
Phosphorus	.018	.024	.021	.025

ANALYTE	C3Z1	C3Z2	C3Z3
Sulfur	.013	.014	.012
Phosphorus	.024	.025	.021

ANALYTE	F1	F2	F3	P1
Sulfur	.014	.015	.012	.010
Phosphorus	.029	.033	.028	.030

Sulfur Test Method: ASTM E1019-03

Phosphorous Test Method: Colormetric

Identification of tested specimen provided by the client.

Robin E. Sinn
Laboratory Director





Corrective Action 1423
Carondelet Division - CA / PA / RGA Database
Corrective Action Type NCR
Date 10/20/2005 Revised 10-25-05
CA Originator C. Ruud

C-2 Doc Package
Document # 21b

Applies to: Weld Material Metrode Lot WO21735 and Lot WO19711 used on C-2 and C-4 coils.

Description of Defect / Non-Conformance

Material does not meet the requirements of NCSX CSPEC – 141-03-09.

Root Cause

The specification was to have included chemical ranges to accommodate the different kinds of weld material used and accepted for the weld procedure qualifications.

Corrective Action

Revise specification.

Estimated Completion Date

Actual Completion Date TBD

A handwritten signature in black ink, appearing to be "C. Ruud".

Signed: C. Ruud

CC: R. Suria, Barry Craig, Joe Edwards, E.J. Kubick

Nonconformance Report: 1423

Project Disposition:

Rev. 10 of NCSX-CSPEC-141-03 now includes two tables for weld wire chemistry (3-1 and 3-2) to permit the use of both bare weld wire and coated wire electrodes.

Approvals:

Phil
Heitzenroeder

Digitally signed by Phil Heitzenroeder
DN: CN = Phil Heitzenroeder, C = US, O
= PPPL, OU = Mech. Eng. Division
Reason: I am the author of this document
Date: 2005.11.07 11:36:36 -05'00'

Procurement Technical Representative

Brad Nelson

Digitally signed by Brad Nelson
DN: cn=Brad Nelson, c=US, o=ORNL,
ou=FED, email=nelsonbe@ornl.gov
Date: 2005.11.07 13:08:04 -05'00'

Responsible Line Manager:



Corrective Action 1320
Carondelet Division - CA / PA / RGA Database
Corrective Action Type NCR
Date 7/5/2005
CA Originator C. Ruud
Pattern Number: C 1, C2 and A1 Coil castings

Description of Defect / Non-Conformance

Lack of test material in violation of paragraph 4.2.2.4 Additional Test Material.

Root Cause

Specification was not communicated to Pattern shop personnel.

Corrective Action

Test coupons were added to pattern and will be cast on all future coils.

Verification of Corrective Action

Pattern was inspected prior to molding C-4 casting.

Preventive Action

Create Inspection and Test Plan summarizing all requirements.

Actual Completion Date

Complete.

A handwritten signature in black ink, appearing to be "C. Ruud", with a long horizontal line extending to the right.

Signed: C. Ruud

CC: Roger Broman, Barry Craig, Joe Edwards, E.J. Kubick

PPPL and EIO agree that additional test material is not available for the C1, C2, and A1 castings, but will be provided for the remaining castings.

This NCR is approved based on EIO's corrective action and the above agreement.

Brad Nelson, NCSX Core Systems Engineering Manager

Phil Heitzenroeder, NCSX MCWF Subcontract Tech. Rep.

TEAM COOPERHEAT-MQS, INC.

RADIOGRAPHIC TECHNIQUE SHEET

FORM 20.3-61 Rev. 4

5512 W. State St-Milwaukee, WI 53208 (414) 771-3060 Fax (414)771-9481 (800) 818-6403 www.cooperheat-mqs.com

CUSTOMER RSS NO.: _____ SHEET: _____ REV: _____
 MQS TECH. NO.: 12970
 MQS RSS NO.: _____

CUSTOMER METALTEK INTERNATIONAL DATE: 1-18-2005
 PART NO. MCWF-C12103989 DESCRIPTION C2 COIL CASTING MATERIAL CF8MNM
 TOTAL NUMBER OF VIEWS 121 NUMBER X-RAY VIEWS 121 NUMBER GAMMA RAY VIEWS 0
 MACH(s) MAKE(s) VARIAN MODEL(s) L2000 S/N(s) 20 MAX KV(s) 7500
 SOURCE(s) N/A
 PROCEDURE SPECIFICATION MSS-SP-54 ACCEPTANCE CRITERIA MSS-SP-54
 MQS PROCEDURE NO. 20.H.010 REV. 0 PENETRATOR SPEC. ASTM E142-86
 PROCESSING: AUTOMATIC PROCESSOR B2000 MANUAL TEMPERATURE 27.2°
 TECHNICIAN J.P., S.S. NDT LEVEL II APPROVED BY Chris Rudolph NDT LEVEL III

VIEW IDENTIFICATION		*				
SOURCE/X-RAY MACH USED		VARIAN				
CURIES OR KV		7500				
MA OR PULSES		N/A				
SOURCE TO FILM DISTANCE		*				
EXPOSURE TIME OR RADS		*				
MATERIAL THICKNESS		I				
MATERIAL GROUP		I				
PENETRATOR SIZE/(AMT)	GP. <input type="checkbox"/>	*		SEE ATTACHED	INFORMATION	
SHIM BLOCK SIZE	GP. <input type="checkbox"/>	N/A				
FILM SIZE		*				
FILM TYPE/BRAND		*				
PB SCREEN, FRONT		.010				
PB SCREEN, BACK		.010				
SENSITIVITY		2-2T				
FILTER TYPE/LOCATION		N/A				
MASKING TYPE/LOCATION		N/A				
ANGLE		*				
NO. OF FILMS IN CASSETTE		*				
VIEWING: SING./DOUB./BOTH		S-B				
FOCAL SPOT SIZE		2 MM				
SKETCH AND/OR REMARKS		SEE ATTACHED				
GEOMETRIC UNSHARPNESS						

THE COPYRIGHT AND ALL OTHER RIGHTS TO THIS DOCUMENT ARE RETAINED BY COOPERHEAT-MQS AND USE THEREOF IN COMPETITION WITH COOPERHEAT-MQS IS PROHIBITED SHEET 1 OF 5

CUSTOMER Metalttek RSS # 12970 PART NO. MCWF-C2

VIEW	SFD	EXP. TIME	FILM TYPE	FILM SIZE	THK. RANGE	IQI
1-2	65"	25 KR	T	14 X 17	2-3/4"	50(2)
2-3	65"	25 KR	T	14 X 17	2-3/4"	50(2)
3-4	65"	25 KR	T	14 X 17	2-3/4"	50(2)
4-5	65"	25 KR	T	14 X 17	2-3/4"	50(2)
5-6	65"	25 KR	T	14 X 17	2-3/4"	50(2)
7-8	65"	25 KR	T	14 X 17	2-3/4"	50(2)
8-9	65"	25 KR	T	14 X 17	2-3/4"	50(2)
9-10	65"	25 KR	T	14 X 17	2-3/4"	50(2)
10-11	65"	25 KR	T	14 X 17	2-3/4"	50(2)
11-12	65"	25 KR	T	14 X 17	2-3/4"	50(2)
12-13	65"	25 KR	T	14 X 17	2-3/4"	50(2)
13-14	65"	25 KR	T	14 X 17	2-3/4"	50(2)
14-15	65"	25 KR	T	14 X 17	2-3/4"	50(2)
15-16	65"	25 KR	T	14 X 17	2-3/4"	50(2)
16-17	65"	25 KR	T	14 X 17	2-3/4"	50(2)
17-18	65"	25 KR	T	14 X 17	2-3/4"	50(2)
18-19	65"	25 KR	T	14 X 17	2-3/4"	50(2)
19-20	65"	25 KR	T	14 X 17	2-3/4"	50(2)
20-21	65"	25 KR	T	14 X 17	2-3/4"	50(2)
21-22	65"	25 KR	T	14 X 17	2-3/4"	50(2)
23-24	65"	25 KR	T	14 X 17	2-3/4"	50(2)
24-25	65"	25 KR	T	7 x 17	2-3/4"	50(2)
26-27	65"	25 KR	T	7 x 17	2-3/4"	50(2)
27-28	65"	25 KR	T	7 x 17	2-3/4"	50(2)
29-30	70"	25 KR	M125	14 x 17	1-1/2"	30(2)
30-31	70"	25 KR	M125	11 x 17	1-1/2"	30(2)
32-33	70"	25 KR	M125	14 x 17	1-1/2"	30(2)
33-34	70"	25 KR	M125	14 x 17	1-1/2"	30(2)
35-36	70"	25 KR	M125	11 x 14	1-1/2"	30(2)
36-37	70"	25 KR	M125	14 x 17	1-1/2"	30(2)
38-39	70"	25 KR	M125	14 x 17	1-1/2"	30(2)
39-40	70"	25 KR	M125	14 x 17	1-1/2"	30(2)
41-42	85"	35 KR	T/M125	14 X 17	1-1/2" - 2"	30, 40
42-43	85"	35 KR	T/M125	14 X 17	1-1/2" - 2"	30, 40
44-45	85"	35 KR	T/M125	14 X 17	1-1/2" - 2"	30, 40
45-46	85"	35 KR	T/M125	14 X 17	1-1/2" - 2"	30, 40
47-48	85"	35 KR	T/M125	14 X 17	1-1/2" - 2"	30, 40
48-49	85"	35 KR	T/M125	14 X 17	1-1/2" - 2"	30, 40
50-51	85"	35 KR	T/M125	14 X 17	1-1/2" - 2"	30, 40
52-53	90"	40 KR	D8/T/AA/Dumb	14 x 17	1-1/2" - 7"	30,40,100,140
53-54	90"	40 KR	D8/T/AA/Dumb	14 x 17	1-1/2" - 7"	30,40,100,140
54-55	90"	40 KR	D8/T/AA/Dumb	14 x 17	1-1/2" - 5"	30,40,100

C-2 Doc Package
Document # 22

CUSTOMER Metaltex RSS # _____ PART NO. MCWF-C 2

VIEW	SFD	EXP. TIME	FILM TYPE	FILM SIZE	THK. RANGE	IQI
55-56	90"	40 KR	D8/T/AA/Dumb	14 x 17	1-1/2" - 5"	30,40,100
56-57	90"	40 KR	D8/T/AA/Dumb	14 x 17	1-1/2" - 5"	30,40,100
57-58	93"	65 KR	D8/AA/T/D8	14 x 17	3" - 7"	60,140
58-59	90"	40 KR	T/M125	14 x 17	1-1/2" - 2"	30,40
59-60	90"	40 KR	T/M125	14 x 17	1-1/2" - 2"	30,40
60-61	90"	40 KR	T/M125	14 x 17	1-1/2" - 2"	30,40
62-63	90"	40 KR	T/M125	14 x 17	1-1/2" - 2"	30,40
63-64	90"	35 KR	T/M125	14 x 17	1-1/2" - 2"	30,40
65-66	90"	150 KR	D8/AA/T/D8	14 x 17	1-1/2"	30(2)
67-68	90"	40 KR	T/M125	14 x 17	3" - 10"	60,140,180,200
68-69	90"	40 KR	T/M125	14 x 17	1-1/2" - 3"	30,40,60
69-70	90"	55 KR	T/M125	14 x 17	1-1/2" - 2"	30,40
V64	90"	40 KR	D8/M125/AA	14 x 17	1-1/2" - 6"	30,40,100,120
71-72	80"	50 KR	M125/M100	11 X 14	1" - 1-1/2"	20,30
72-73	80"	90 KR	AA/M125/T	14 x 17	1-1/2" - 5"	30,50,60,80,100
73-74	80"	35 KR	AA/M125/M100/T	14 x 17	1-1/2" - 5"	30,50,60,80,100
74-75	80"	35 KR	T/M125	14 x 17	1-1/2" - 4"	30,40,80
75-76	80"	35 KR	T/M125	14 x 17	1-1/2" - 4"	30,40,80
76-77	80"	30 KR	T/M125	14 x 17	1-1/2" - 2"	30,40
77-78	80"	30 KR	T/M125	11 x 14	1-1/2" - 2"	30,40
78-79	80"	35 KR	T/M125	14 x 17	1-1/2" - 3"	30,40,60
79-80	80"	35 KR	T/M125	14 x 17	1-1/2" - 2"	30,40
80-81	80"	30 KR	T/M125	14 x 17	1-1/2" - 2"	30,40
81-82	80"	30 KR	T/M125	14 x 17	1-1/2" - 2"	30,40
83-84	80"	35 KR	T/M125	7 x 17	1-1/2" - 2"	30,40
85-86	80"	35 KR	T/M125	14 x 17	1-1/2" - 3"	30,40,60
86-87	80"	30 KR	T/M125	14 x 17	1-1/2" - 2"	30,40
87-88	80"	60 KR	D8/M125/T	14 x 17	1-1/2" - 6"	30,40,120(2)
88-89	80"	30 KR	T/M125	14 x 17	1-1/2" - 2"	30,40
89-90	80"	40 KR	AA/M125/T	14 x 17	1-1/2" - 3"	30,40,60
90-91	80"	30 KR	T/M125	14 x 17	1-1/2" - 2"	30,40
92-93	80"	30 KR	T/M125	14 x 17	1-1/2" - 2"	30,40
V94	72"	25 KR	T	14 x 17	2-3/4"	50
V95	72"	25 KR	T	8 x 10	2-3/4"	50
96-97	65"	25 KR	T/T	14 x 17	2-3/4"	50(2)
97-98	65"	25 KR	T/T	14 x 17	2-3/4"	50(2)
98-99	65"	25 KR	T/T	14 x 17	2-3/4"	50(2)
100-101	65"	25 KR	T/T	14 x 17	2-3/4"	50(2)
101-102	65"	25 KR	T/T	14 x 17	2-3/4"	50(2)
102-103	65"	25 KR	T/T	14 x 17	2-3/4"	50(2)
103-104	65"	25 KR	T/T	14 x 17	2-3/4"	50(2)
104-105	65"	25 KR	T/T	14 x 17	2-3/4"	50(2)
105-107	65"	25 KR	T/T	14 x 17	2-3/4"	50(2)

Energy Industries of Ohio
Manufacturing and Test Sequence (MTS) Serial Number C-2

1 OF 11 CO# 40851 Dated 3-9-05 Revision: Rev 4 Dated Issued: 4-18-05

OPER. #	STATION	DESCRIPTION OF PROCESS	Name	Date
10	QUALITY RELEASE	REVIEW AND APPROVE MTS. RECEIVED APPROVAL FROM EIO ON <u>4/12/05</u> FROM <u>Rate D.</u> SIGNED QUALITY MANAGER	<u>CTR</u>	<u>4/12/05</u>
15	PATTERN NPAT SOP 0100REV2	APPLY APPROPRIATE PART NUMBER, SERIAL NUMBER, AND FOUNDRY MARK, TO THE PATTERN. CAST ON BARS REQUIRED. Place numbers on the bars as to their location.	<u>By</u>	<u>4-14</u>
20	COREMAKE CORE SOP 0100 REV 6 CALIBRATION PER CORE SOP 0200R4/0300R6	MAKE CORES IN SAND MIXTURES AS DESCRIBED BY METALTEK ENGINEERING AND VERIFIED IN MODELING TRIALS. METALTEK CORE SOP 0100 REV 6) CORE WASH WITH ZIRCONIUM CORE WASH. (CALIBRATION OF EQUIPMENT REQUIRED PER CORE SOP 0200,R4 / 0300,R6) VERIFY COUNT AND INSPECT.	<u>By</u>	<u>4-14</u>
30	MOLD MOLD SOP 0400 REV 8 CALIBRATION PER MOLD SOP 0900 REV 5 PREPARATION PER MOLD SOP 1100R2/1200R2/1300R1 SAND TESTING PER MOLD SOP 1400R2/1500R3/1600R2	MOLD PER WORK INSTRUCTIONS IN MAPICS ROUTING AND SOPS REFERENCED. ENGINEER OF RECORD - ROGER BROMAN, CONSULT ON MOLD-RELATED CONCERNS. MOLD MATERIALS REQUIRED PER MAPICS BOM. NOTIFY ENGINEER OF ANY SUBSTITUTIONS.	<u>By</u>	<u>4-14</u>
40	POUR MELT SOP 0100R5 MELT SOP 0700R2 MELT SOP 0600R2	METAL MUST BE AOD REFINED OR AOD INGOT. VIRGIN METAL ADDITIONS ALLOWED. RECORD POURING TEMPERATURE: <u>2730</u> CASTING POURED AT: <u>2730°F</u> DATE: <u>4/15/2005</u> HEAT #'s: <u>29060, 29061, 29062, 29063</u> ELAPSED POUR TIME <u>1:20</u> KEEL BLOCKS POURED: <u>cast-on 3 Laddles</u> Sample from ladle to be analyzed for final chemical analysis and reported on material certifications. Sample Taken by: <u>SR</u> Analyzed: <u>G. Huit</u> Date: <u>4/15/2005</u>	<u>J. Golobok</u>	<u>4-15-05</u>
50	MELT SOP 0800R2	SHAKEOUT	<u>CH</u>	<u>4/18/05</u>

60	ARC RISE SOP 0100R1	REMOVE RISERS AS DIRECTED BY SUPERVISOR.	RLC	4-21-05 <i>cut High</i>
70	HEAT TREAT HEAT SOP 0103R5	SOLUTION ANNEAL. MAKE SURE TO BLOCK ALL FLANGES OF FORM AND RACETRACK TO MINIMIZE CREEP DISTORTION. Soak Temp: 2050F, Soak Time: 4HR + 1/2 HR/IN, Quench Type: Air Cool	DLS	4-27-05
75	PHYSICAL TESTING	OBTAIN TEST SPECIMENS AND SUBMIT FOR PHYSICAL TESTING. REPORT RESULTS AS PART OF STEP 510.	Chl	4/29/05
NOTE		THE ORDER OF CLEANING PROCESSES MAY BE ALTERED DUE TO CAPACITY CONSTRAINTS. HOLD POINTS AND COMPLIANCE WILL NOT BE COMPROMISED. EIO WILL BE ADVISED OF ALL CHANGES THAT MAY RESULT IN A REQUEST FOR DEVIATION FROM REQUIREMENTS.	.	
80	GRIND GSAW SOP 0100R3	SWING GRIND TO REMOVE RISER REMAINS AND FLASH IF REQUIRED.	TJ	5-4
85	GRIND GCHI SOP 0100R2	CHIP AND HAD GRIND SURFACE OF PART AS REQUIRED FOR CONTOUR.	1st. SHIFT MIKE TOM	(5-5-05) (5-6-05)
90	SAND BLAST BLAS SOP 0100R6	SANDBLAST (REMOVE ALL BLAST MATERIAL FROM CASTING) SANDBLASTING WILL BE DONE USING RECYCLED SHARP ANGULAR AGGREGATE.	1/3	5-6-05
NOTICE	WITNESS NOTIFICATION HOLD FOR EIO APPROVAL	PROVIDE NOTICE TO EIO AND DCMA AT LEAST FIVE DAYS IN ADVANCE OF LAYOUT. EIO NOTIFIED ON _____ DCMA NOTIFIED ON _____ APPROVAL RECEIVED ON _____	Q ENG OR QA MGR	
100	LAYOUT SOP LAYOUT XX, TBD	INSPECT CASTING TO VERIFY DIMENSIONS. THIS STEP MAY BE DELAYED. DIMENSIONED _____ DATE _____ RELEASED _____ (ENGINEER ONLY)		
110	VISUAL INSPECTION CQP-500 REV 4	VISUALLY INSPECT 100% of COMPONENT ACCORDING TO ASTM A802 LEVEL 3 ALL CONDITIONS. IF OK CHECK HERE _____ IF REJECTED CHECK HERE _____ . MARK AND REPAIR AT STEP 120.	VT- LEVEL II	

90 Rev
5 issued
5/10/05
Chl

Energy Industries of Ohio
Manufacturing and Test Sequence (MTS) Serial Number C-2

2 OF 11 CO# 40851 Dated 3-9-05 Revision: Rev 5 Dated Issued: 5-10-05

60	ARC RISE SOP 0100R1	REMOVE RISERS AS DIRECTED BY SUPERVISOR.		
70	HEAT TREAT HEAT SOP 0103R5	SOLUTION ANNEAL. MAKE SURE TO BLOCK ALL FLANGES OF FORM AND RACETRACK TO MINIMIZE CREEP DISTORTION. Soak Temp: 2050F, Soak Time: 4HR + 1/2 HR/IN, Quench Type: Air Cool		
75	PHYSICAL TESTING	OBTAIN TEST SPECIMENS AND SUBMIT FOR PHYSICAL TESTING. REPORT RESULTS AS PART OF STEP 510.		
NOTE		THE ORDER OF CLEANING PROCESSES MAY BE ALTERED DUE TO CAPACITY CONSTRAINTS. HOLD POINTS AND COMPLIANCE WILL NOT BE COMPROMISED. EIO WILL BE ADVISED OF ALL CHANGES THAT MAY RESULT IN A REQUEST FOR DEVIATION FROM REQUIREMENTS.		
80	GRIND GSWA SOP 0100R3	SWING GRIND TO REMOVE RISER REMAINS AND FLASH IF REQUIRED.		
85	GRIND GCHI SOP 0100R2	CHIP AND HAD GRIND SURFACE OF PART AS REQUIRED FOR CONTOUR.		
90	SAND BLAST BLAS SOP 0100R6	SANDBLAST (REMOVE ALL BLAST MATERIAL FROM CASTING) SANDBLASTING WILL BE DONE USING RECYCLED SHARP ANGULAR AGGREGATE.		
NOTICE	WITNESS NOTIFICATION HOLD FOR EIO APPROVAL	PROVIDE NOTICE TO EIO AND DCMA AT LEAST FIVE DAYS IN ADVANCE OF LAYOUT. EIO NOTIFIED ON <u>5/4/03</u> DCMA NOTIFIED ON <u>5/4/03</u> APPROVAL RECEIVED ON <u>5/10/05</u> <i>CTR</i> <i>as long as length check performed ✓</i>	Q ENG OR QA MGR	<i>CTR</i>
100	LAYOUT SOP LAYOUT 0100	INSPECT CASTING TO VERIFY DIMENSIONS. THIS STEP MAY BE DELAYED. DIMENSIONED _____ DATE _____ RELEASED _____ (ENGINEER ONLY) NOTE: THE FIRST PART PRODUCED OF EACH TYPE A, B AND C WILL BE DIMENSIONED BY LAWTON PATTERN. IF DIMENSIONED BY LAWTON IT WILL BE DOCUMENTED HERE. Subsequent casting done internally per Romer Arm.	JRS	5/11/05
110	VISUAL INSPECTION CQP-500 REV 4	VISUALLY INSPECT 100% of COMPONENT ACCORDING TO ASTM A802 LEVEL 3 ALL CONDITIONS. IF OK CHECK HERE _____ IF REJECTED CHECK HERE <u>✓</u> . MARK AND REPAIR AT STEP 120.	VT - LEVEL II KRA	5/12/05

Energy Industries of Ohio
Manufacturing and Test Sequence (MTS) Serial Number C-2

3 OF 11 CO# 40851 Dated 3-9-05 Revision: Rev 5 Dated Issued: 5-10-05

NOTICE	WITNESS NOTIFICATION	PROVIDE NOTICE TO EIO AND DCMA AT LEAST FIVE DAYS IN ADVANCE OF LP STEP. EIO NOTIFIED ON <u>5/10/05</u> DCMA NOTIFIED ON <u>5/10/05</u>	Q ENG OR QA MGR	
115	100% L.P. CQP 0300 REV 10	L.P. 100% OF COMPONENT. ACCEPTANCE PER ASTM A903. ACCEPTANCE CRITERIA-LEVEL 1 FOR HIGH STRESSED AREAS, LEVEL 2 FOR ALL OTHER AREAS. SEE LP DRAWING. IF OK CHECK HERE _____ IF REJECTED CHECK HERE <input checked="" type="checkbox"/> MARK AND REPAIR AT STEP 120.	LP - LEVEL II	<i>CHK</i>
120	WELD SOP 0100 REV 7	EXCAVATE ANY DEFECTS FOUND DURING 100% VISUAL AND LP INSPECTION.		<i>KRA</i> <i>5-12-05</i>
125	GRIND GCHI SOP 0100R2	CHIP AND HAND GRIND EXCAVATION AS REQUIRED.		<i>JP</i> <i>5-12-05</i> <i>5-13-05</i>
130	L.P. EXCAVATION CQP-300 REV 10	L.P. ALL EXCAVATIONS PRIOR TO WELDING TO ENSURE REMOVAL OF DEFECT. ACCEPTANCE PER A903. ACCEPTANCE CRITERIA-LEVEL 1 FOR HIGH STRESSED AREAS, LEVEL 2 FOR ALL OTHER AREAS. SEE LP DRAWING. IF OK CHECK HERE _____ IF REJECTED SEND BACK TO STEP 125.	LP - LEVEL II	<i>Held pending RT. CTR</i>
165	SAND BLAST BLAS SOP 0100R6	SANDBLAST (REMOVE ALL BLAST MATERIAL FROM CASTING) SANDBLASTING WILL BE DONE USING RECYCLED SHARP ANGULAR AGGREGATE.		<i>CA</i> <i>5-13</i>
170	HOLD POINT WELD MAP	MAP ALL WELDS WITH DIGITAL PHOTO/MAPS INDICATING LOCATION. SERIALIZE DEFECTS ON CASTING, USE SCALE IN PHOTOS AND DOCUMENT SIZE. THIS IS TO BE PERFORMED BY SUPERVISOR, INSPECTION LEAD MAN OR THEIR DESIGNEE, FILE WITH QA. USE YELLOW MARKER. MUST SEND REPORT ON ALL WELDS OVER 10% OF NOMINAL WALL THICKNESS TO CUSTOMER. DEFECTS > 10% YES _____, REPORT SENT BY _____ DATE _____ DEFECTS < 10% _____ SIGN BY QA ENG. MAJOR WELD REPAIRS MAY NOT PROCEED UNTIL INFORMATION IS SUBMITTED.		<i>Delayed test after X-ray</i> <i>CHK</i>
NOTICE	WITNESS NOTIFICATION	PROVIDE NOTICE TO EIO AND DCMA AT LEAST FIVE DAYS IN ADVANCE OF X-RAY AND DIMENSIONAL STEPS. EIO NOTIFIED ON <u>5/12/05</u> DCMA NOTIFIED ON <u>5/12/05</u>	Q ENG OR QA MGR	
190	X-RAY AT MQS MQS PROCEDURE 20.H.010 REV 0	X-RAY PER TECHNIQUE # 12726 USE CALIBRATED DENSITOMETER FOR DENSITY VERIFICATION. WHEN MARKING USE BLACK MARKERS. ATTACH TECHNIQUE, READER SHEET FOR ALL RADIOGRAPHS. MUST INDICATE RADIOGRAPHER AND ASNT CERTIFICATION LEVEL ON READER SHEET.	RT - LEVEL II	<i>CHK</i> <i>5/12</i> <i>RT</i> <i>complete</i> <i>5/24/05</i>

Energy Industries of Ohio
Manufacturing and Test Sequence (MPS) Serial Number C-2

4 OF 11 CO# 40851 Dated 3-9-05 Revision Rev 5 Dated Issued: 5-10-05

C-2 Doc Package
Document # 23

210	X-RAY CQP 401 REV 5	X-RAY INTERPRETATION. ACCEPTANCE MSS SP 54. ATTACH TECHNIQUE, READER SHEET FOR ALL RADIOGRAPHS. MUST INDICATE RADIOGRAPHER AND ASNT CERTIFICATION LEVEL ON READER SHEET. IF OK CHECK HERE _____ AND SEND TO STEP 340. REJECTED CHECK HERE <input checked="" type="checkbox"/> MARK UP DEFECTS AND SEND THE CASTING TO STEP 220.	RT - LEVEL II Completed 5/24/05 at MGS	<i>lent</i>	 <i>Review 4/1/05 6/7/05</i>
220	WELD SOP 0100 REV 7	EXCAVATE ANY DEFECTS FOUND DURING RADIOGRAPHY.	<i>AC</i>	<i>6-7-05</i>	
225	GRIND GCHI SOP 0100R2	CHIP AND HAND GRIND EXCAVATION AS REQUIRED.	<i>DWP</i>	<i>6-8-05</i>	
230	L.P. EXCAVATION CQP-300 REV 10	L.P. ALL EXCAVATIONS PRIOR TO WELDING TO ENSURE REMOVAL OF DEFECT. ACCEPTANCE PER A903. ACCEPTANCE CRITERIA-LEVEL 1 FOR HIGH STRESSED AREAS, LEVEL 2 FOR ALL OTHER AREAS. SEE LP DRAWING. IF OK CHECK HERE _____ IF REJECTED SEND BACK TO STEP 225.	LP - LEVEL II		
240	HOLD POINT WELD MAP	MAP ALL WELDS WITH DIGITAL PHOTO/MAPS INDICATING LOCATION . SERIALIZE DEFECTS ON CASTING, USE SCALE IN PHOTOS AND DOCUMENT SIZE. THIS IS TO BE PERFORMED BY SUPERVISOR, INSPECTION LEAD MAN OR THEIR DESIGNEE, FILE WITH QA. MUST SEND REPORT ON ALL WELDS OVER 10% OF NOMINAL WALL THICKNESS TO CUSTOMER. DEFECTS > 10% YES <u>X</u> , REPORT SENT BY <u>R Surin</u> DATE <u>6/1/05</u> DEFECTS < 10% _____ SIGN BY QA ENG. MAJOR WELD REPAIRS MAY NOT PROCEED UNTIL INFORMATION IS SUBMITTED. MUST SEND REPORT ON ALL WELDS OVER 10% OF NOMINAL WALL THICKNESS TO CUSTOMER PRIOR TO REPAIR. ONCE THE REPORT IS SENT, WELDING MAY START.	<i>lent</i>	<i>6/1/05</i>	
NOTICE	WITNESS NOTIFICATION	PROVIDE NOTICE TO EIO AND DCMA AT LEAST FIVE DAYS IN ADVANCE OF WELD STEP. EIO NOTIFIED ON <u>5/25/05</u> DCMA NOTIFIED ON <u>5/25/05</u> <i>for June 1 start</i>	Q ENG OR QA MGR	<i>Qbe</i>	
260	QA APPROVAL HOLD POINT	QA TO APPROVE ELECTRODE PRIOR TO USE. PROCEDURE USED: <u>15 - GMAW CF8MN MOD</u> MATERIAL USED: <u>ENM 4455 / Heat 52743</u> <u>20 - SMAW CF8MN MOD</u> MATERIAL USED: <u>Metrolite 13816 NF Lot W019711</u> QUALITY ENG. Name: <u>R. M. J.</u> Date: <u>6/1/05</u>		<i>Go to New 6.</i>	
270	WELD SOP 0100 REV 7	WELD REPAIR DEFECTS AS MARKED. FOR WELDS <2" - WPS 10-SMAW-CF8MNMN MOD REV 1 FOR WELDS <8" - WPS 15-GMAW-CF8MNMN MOD REV 2 ADD WPS FOR VERTICAL WELDS.		<i>6/7/05</i>	
280	GRIND GCHI SOP 0100R2	HAND GRIND WELDS.		<i>NA</i> ↓	

210	X-RAY CQP 401 REV 5	X-RAY INTERPRETATION. ACCEPTANCE MSS SP 54. ATTACH TECHNIQUE, READER SHEET FOR ALL RADIOGRAPHS. MUST INDICATE RADIOGRAPHER AND ASNT CERTIFICATION LEVEL ON READER SHEET. IF OK CHECK HERE _____ AND SEND TO STEP 340. REJECTED CHECK HERE _____ MARK UP DEFECTS AND SEND THE CASTING TO STEP 220.	RT - LEVEL II	
220	WELD SOP 0100 REV 7	EXCAVATE ANY DEFECTS FOUND DURING RADIOGRAPHY.		
225	GRIND GCHI SOP 0100R2	CHIP AND HAND GRIND EXCAVATION AS REQUIRED.		
230	L.P. EXCAVATION CQP-300 REV 10	L.P. ALL EXCAVATIONS PRIOR TO WELDING TO ENSURE REMOVAL OF DEFECT. ACCEPTANCE PER A903. ACCEPTANCE CRITERIA-LEVEL 1 FOR HIGH STRESSED AREAS, LEVEL 2 FOR ALL OTHER AREAS. SEE LP DRAWING. IF OK CHECK HERE <input checked="" type="checkbox"/> IF REJECTED SEND BACK TO STEP 225.	LP - LEVEL II	
240	HOLD POINT WELD MAP	MAP ALL WELDS WITH DIGITAL PHOTO/MAPS INDICATING LOCATION . SERIALIZE DEFECTS ON CASTING, USE SCALE IN PHOTOS AND DOCUMENT SIZE. THIS IS TO BE PERFORMED BY SUPERVISOR, INSPECTION LEAD MAN OR THEIR DESIGNEE, FILE WITH QA. MUST SEND REPORT ON ALL WELDS OVER 10% OF NOMINAL WALL THICKNESS TO CUSTOMER. DEFECTS>10% YES _____, REPORT SENT BY _____ DATE _____ DEFECTS < 10 % _____ SIGN BY QA ENG. MAJOR WELD REPAIRS MAY NOT PROCEED UNTIL INFORMATION IS SUBMITTED. MUST SEND REPORT ON ALL WELDS OVER 10% OF NOMINAL WALL THICKNESS TO CUSTOMER PRIOR TO REPAIR. ONCE THE REPORT IS SENT, WELDING MAY START.		
NOTICE	WITNESS NOTIFICATION	PROVIDE NOTICE TO EIO AND DCMA AT LEAST FIVE DAYS IN ADVANCE OF WELD STEP. EIO NOTIFIED ON _____ DCMA NOTIFIED ON _____	Q ENG OR QA MGR	
260	QA APPROVAL HOLD POINT	QA TO APPROVE ELECTRODE PRIOR TO USE. PROCEDURE USED: _____ MATERIAL/LOT USED: _____ QUALITY ENG. Name: _____ Date: _____		
270	WELD SOP 0100 REV 7	WELD REPAIR DEFECTS AS MARKED. FOR WELDS <2" - WPS 10-SMAW-CF8MNMN MOD REV 1 FOR WELDS <8" - WPS 15-GMAW-CF8MNMN MOD REV 2 ADD WPS FOR VERTICAL WELDS.		
280	GRIND GCHI SOP 0100R2	HAND GRIND WELDS.	AB	6-8-05

Handwritten notes:

RT - LEVEL II

6-7-05 should be doc on S220

6-7-05

LP - LEVEL II

Q ENG OR QA MGR

6-7-05

Start 6/7/05

6-8-05

290	L.P. WELD CQP 0300 REV 10	L.P. WELD REPAIRS ACCEPTANCE PER ASTM A903. ACCEPTANCE CRITERIA-LEVEL 1 FOR HIGH STRESSED AREAS, LEVEL 2 FOR ALL OTHER AREAS. SEE LP DRAWING. IF OK CHECK HERE _____ WASH AND SEND TO STEP 300. IF REJECTED CHECK HERE <input checked="" type="checkbox"/>	LP- LEVEL II <i>TRC</i> 6-8-05	
	REPEAT	REPEAT STEPS 220 TO 290 AS REQUIRED TILL CLEAR THROUGH VISUAL INSPECTION & PENETRANT INSPECTION. DOCUMENT REWORK ON STEPS S220 TO S290 ON LAST PAGE OF MTS. IF OK CHECK HERE _____ AND PROCEED TO STEP 295.	<i>See S220</i>	
295	TEST MAG PERM SOP MAG PERM 100, REV 1	TEST MAG PERMEABILITY REPAIR AREAS RECORD ON WELD MAP LIST. TEST AT LEAST 5 POINTS PER WELD. ACCEPTANCE 1.02. IF OK CHECK HERE <input checked="" type="checkbox"/> AND GO TO STEP 300. IF REJECTED CHECK HERE _____.	CA	
296	GRIND GCHI SOP 0100R2	GRIND AREAS OF NON COMPLIANCE AND RETURN TO STEP 295. REPEAT UNTIL COMPLIANCE IS ACHIEVED.	CA	
300	X-RAY (NOTE)	IF RADIO GRAPHED AREAS ARE GREATER THAN FOUR TO FIVE INCHES THE CASTING WILL BE SENT TO MQS. SEND TO MQS CHECK HERE <input checked="" type="checkbox"/> RADIOGRAPH AT CAF CHECK HERE _____.	QA ENGINE ER	<i>RS</i>
310 A	MQS X-RAY DEFECTS REPAIRED BY WELDING	X-RAY PER TECHNIQUE # 12726 USE CALIBRATED DENSITOMETER FOR DENSITY VERIFICATION. ATTACH TECHNIQUE, READER SHEET FOR ALL RADIOGRAPHS. MUST INDICATE RADIOGRAPHER AND ASNT CERTIFICATION LEVEL ON READER SHEET.	LEVEL II <i>R. Quinn</i> <i>RT-10/10/05</i>	
310 B	CAF X-RAY DEFECTS REPAIRED BY WELDING CQP 401 REV 5	X-RAY PER TECHNIQUE # 12726 USE CALIBRATED DENSITOMETER FOR DENSITY VERIFICATION. ATTACH TECHNIQUE, READER SHEET FOR ALL RADIOGRAPHS. MUST INDICATE RADIOGRAPHER AND ASNT CERTIFICATION LEVEL ON READER SHEET.	RT - LEVEL II RT-10/10/05	
320	X-RAY CQP 401 REV 5	X-RAY INTERPRETATION. ACCEPTANCE MSS SP 54. ATTACH TECHNIQUE, READER SHEET FOR ALL RADIOGRAPHS. MUST INDICATE RADIOGRAPHER AND ASNT CERTIFICATION LEVEL ON READER SHEET. IF OK CHECK HERE _____ AND SEND TO STEP 340. REJECTED CHECK HERE <input checked="" type="checkbox"/> MARK UP DEFECTS AND SEND THE CASTING TO STEP 220. <i>OK on Reshore 4/10</i>	RT - LEVEL II <i>Ronk</i> <i>RK</i> <i>6/15/05</i> <i>6/16</i>	
	REPEAT	REPEAT STEPS 220 TO 320 AS REQUIRED TILL WELDS CLEAR X-RAY. DOCUMENT REWORK ON A SUPPLEMENTAL MTS	QA ENG. <i>CA</i> <i>6/15/05</i>	

1st loop repair #1

Doc Repeats on last page
78 CA

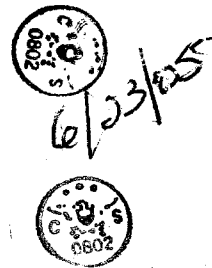

340	SAND BLAST BLAS SOP 0100R6	SANDBLAST (REMOVE ALL BLAST MATERIAL FROM CASTING) SANDBLASTING WILL BE DONE USING RECYCLED SHARP ANGULAR AGGREGATE.		MTW 6/16/05
NOTICE	WITNESS NOTIFICATION	PROVIDE NOTICE TO EIO AND DCMA AT LEAST FIVE DAYS IN ADVANCE OF VISUAL AND LP STEPS. EIO NOTIFIED ON <u>6/20</u> DCMA NOTIFIED ON <u>6/20</u>	Q ENG OR QA MGR	GBR
350	FINAL VISUAL INSPECTION CQP-500 REV 4	VISUALLY INSPECT 100% OF COMPONENT ACCORDING TO ASTM A802 LEVEL 2 ALL CONDITIONS. IF OK CHECK HERE _____ IF REJECTED CHECK HERE <input checked="" type="checkbox"/> . MARK AND REPAIR AT STEP 385. MUST BE PERFORMED BY LEVEL II in VT.	VT - LEVEL II HJA 6-24-05	
360	FINAL L.P. CQP 0300 REV 10	FINAL L.P. 100% OF COMPONENT. ACCEPTANCE PER ASTM A903. ACCEPTANCE CRITERIA-LEVEL 1 FOR HIGH STRESSED AREAS, LEVEL 2 FOR ALL OTHER AREAS. SEE LP DRAWING. IF OK CHECK HERE _____ WASH AND SEND TO STEP 455. IF REJECTED CHECK HERE <input checked="" type="checkbox"/>	LP - LEVEL II JPS 6-23	
380	WELD SOP 0100 REV 7	EXCAVATE ANY DEFECTS FOUND DURING FINAL PENETRANT INSPECTION.	N/A	
385	GRIND GCHI SOP 0100R2	CHIP AND HAD GRIND EXCAVATION AS REQUIRED.	AB 5/5/06/28-05	
390	L.P. EXCAVATION CQP-300 REV 10	L.P. ALL EXCAVATIONS PRIOR TO WELDING TO ENSURE REMOVAL OF DEFECT. ACCEPTANCE PER A903. IF OK CHECK HERE <input checked="" type="checkbox"/> IF REJECTED SEND BACK TO STEP 385.	LP - LEVEL II ADR 6-23-05	
400	HOLD POINT WELD MAP	MAP ALL WELDS WITH DIGITAL PHOTO/MAPS INDICATING LOCATION. SERIALIZE DEFECTS ON CASTING, USE SCALE IN PHOTOS AND DOCUMENT SIZE. THIS IS TO BE PERFORMED BY SUPERVISOR, INSPECTION LEAD MAN OR THEIR DESIGNEE. FILE WITH QA. MUST SEND REPORT ON ALL WELDS OVER 10% OF NOMINAL WALL THICKNESS TO CUSTOMER. DEFECTS.>10% YES _____, REPORT SENT BY _____ DATE _____ DEFECTS < 10 % _____ SIGN BY QA ENG. MAJOR WELD REPAIRS MAY NOT PROCEED UNTIL INFORMATION IS SUBMITTED. MUST SEND REPORT ON ALL WELDS OVER 10% OF NOMINAL WALL THICKNESS TO CUSTOMER PRIOR TO REPAIR. ONCE THE REPORT IS SENT, WELDING MAY START.	N/A	



Energy Industries of Ohio
Manufacturing and Test Sequence (MTS) Serial Number C-2

7 OF 11 CO# 40851 Dated 3-9-05 Revision: Rev 6 Dated Issued: 5-29-05

C-2 Doc Package Document # 23

420	QA APPROVAL HOLD POINT	QA TO APPROVE ELECTRODE PRIOR TO USE. PROCEDURE USED: _____ MATERIAL/LOT USED: _____ QUALITY ENG. Name: _____ Date: _____	N/A	
430	WELD SOP 0100 REV 7	WELD REPAIR DEFECTS AS MARKED. FOR WELDS <2" - WPS 10-SMAW-CF8MNMN MOD REV 1 FOR WELDS <8" - WPS 15-GMAW-CF8MNMN MOD REV 2 ADD WPS FOR VERTICAL WELDS.	N/A	
440	GRIND GCHI SOP 0100 REV 2	HAND GRIND WELDS.		
450	L.P. WELDS CQP 0300 REV 10	L.P. WELD REPAIRS ACCEPTANCE PER ASTM A903. IF OK CHECK HERE _____ WASH AND SEND TO STEP 460. IF REJECTED CHECK HERE _____ AND RETURN TO STEP 440.	LP LEVEL II	
	REPEAT	REPEAT STEPS 350 TO 450 AS REQUIRED TILL WELDS CLEAR FINAL LIQUID PENETRANT INSPECTION. DOCUMENT REWORK ON A SUPPLEMENTAL MTS	QA ENG.	
NOTICE	WITNESS NOTIFICATION	PROVIDE NOTICE TO EIO AND DCMA AT LEAST FIVE DAYS IN ADVANCE OF VISUAL AND LP STEPS. EIO NOTIFIED ON <u>6/20/05</u> DCMA NOTIFIED ON <u>6/20/05</u>	Q ENG OR QA MGR	<i>[Signature]</i>
460	FINAL VISUAL INSPECTION CQP-500 REV 4	VISUALLY INSPECT 100% of COMPONENT ACCORDING TO ASTM A802 LEVEL 2 ALL CONDITIONS. IF OK CHECK HERE _____ IF REJECTED CHECK HERE <input checked="" type="checkbox"/> MARK AND REPAIR AT STEP 390. MUST BE PERFORMED BY LEVEL II in VT.	VT - LEVEL II <i>KRA 6-24-05</i>	
470	FINAL L.P. CQP 0300 REV 10	FINAL L.P. 100% OF COMPONENT. ACCEPTANCE PER ASTM A903. ACCEPTANCE CRITERIA-LEVEL 1 FOR HIGH STRESSED AREAS, LEVEL 2 FOR ALL OTHER AREAS. SEE LP DRAWING. IF OK CHECK HERE <input checked="" type="checkbox"/> WASH AND SEND TO STEP 455. IF REJECTED CHECK HERE _____	LP - LEVEL II <i>JDR 6-23-05</i>	
480	TEST MAG PERM SOP MAG PERM 100, REV 1	TEST MAG PERMEABILITY REPAIR AREAS. RECORD ON WELD MAP LIST. TEST AT LEAST 5 POINTS PER WELD. ACCEPTANCE 1.02. IF OK CHECK HERE <input checked="" type="checkbox"/> AND GO TO STEP 430. IF REJECTED CHECK HERE _____ <i>Performed on entire part 100% Pictures provided to DCMA</i>	RC <i>23-05</i>	
490	GRIND GCHI SOP 0100R2	GRIND AREAS OF NON COMPLIANCE AND RETURN TO STEP 451. REPEAT UNTIL COMPLIANCE IS ACHIEVED.	N/A	

NOTICE	WITNESS NOTIFICATION	PROVIDE NOTICE TO EIO AND DCMA AT LEAST FIVE DAYS IN ADVANCE OF MAG PERM STEPS. EIO NOTIFIED ON <u>6/20</u> DCMA NOTIFIED ON <u>6/20</u>	Q ENG OR QA MGR	
500	FINAL MAG PERM INSPECTION SOP MAG PERM 100, REV 1	PERFORM MAG PERM TESTING WITH SEVRIN GAUGE. ACCEPTANCE 1.02. CHECK THE ENTIRE SURFACE ON A 6"BY6" GRID. REPORT RESULTS. USE A 6" SQUARE BLOCK TO INDICATE TEST LOCATIONS AND RECORD RESULTS. COMPLIANT AREAS WILL NOT BE MARKED. MARK NONCOMPLIANT AREAS WITH AN "X" FOR REPAIR. OK CHECK HERE _____ AND GO TO STEP 530. IF REJECTED CHECK HERE _____.	N/A	
510	GRIND GCHI SOP 0100 REV 2	HAND GRIND WITH SUITABLE CONE OR OTHER SIMILAR GRINDER AS REQUIRED TO ENSURE REMOVAL OF MATERIAL TO ACHIEVE MAG PERM REQUIREMENT. CIRCLE AREA REMEDIATE FOR RETEST.		
520	RETEST MAG PERM SOP MAG PERM 100, REV 1	RETEST MAG PERMEABILITY AT FAILED TEST POINTS. MARK NONCOMPLIANT AREAS WITH AN "X" FOR REPAIR. ACCEPTANCE 1.02. IF OK CHECK HERE _____ . IF REJECTED CHECK HERE _____ RETURN TO STEP 510.	↓	
530	DOC. REVIEW	REVIEW DOCUMENTS AS REQUIRED IN CAF CHECKLIST, ALL DOCUMENTS NOTED TO BE ACCESSIBLE FOR AUDITING. (SHIPPER, C OF C, M.T.R., M.T.S., INSPECTION REPORT, X-RAY READER SHEETS AND HEAT TREAT CHARTS)	ckn	6/24/05
NOTICE	RELEASE FROM EIO	PROVIDE DOCUMENTS TO EIO. SENT ON <u>6/24/05</u> BY <u>ckn</u> . RECEIVED RELEASE FROM EIO ON _____.	Q ENG OR QA MGR	
540	PACK AND SHIP	PACKAGE AND SHIP TO MAJOR TOOL.		
1000	REVISION HISTORY	ORIGINAL 12-14-04. Approved 12-14-04. Revision level 1- Revised 1-26-05 new page 8, correct High stress areas, Revision level 2 3-16-05, delete LO step 455. Revision 3 3-28-05 Added note regarding hold point at weld step 400. Revision level 4 written for C-2 casting 4-18-05. Rev 5 added Layout SOP# and note regarding first casting layout responsibility. 5-10-05 Rev 6 added step 420 and "LOT" to step 260 and 420.5-29-05	CARUUD	

C-2 Doc Package
Document # 23



GENERAL ISOMETRIC
VIEW FROM TOP SIDE

TABS DESIGNATE
CRITICAL AREA

RED AREA INDICATES HIGH STRESSED AREA

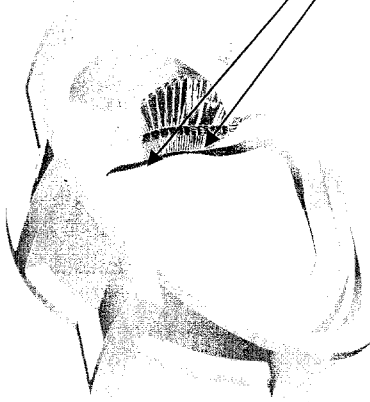

TOP SIDE ISOMETRIC

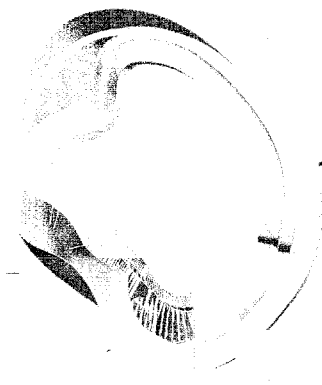

TOP SIDE VIEW

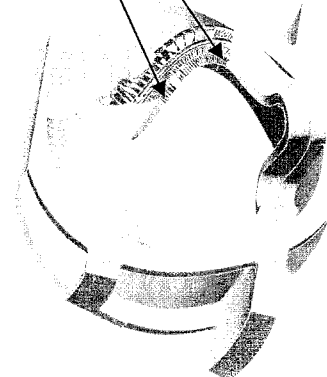

BOTTOM SIDE ISOMETRIC



BOTTOM SIDE VIEW

start 4/15/05

	REPEAT STEPS	SUPPLEMENTAL REPAIR STEPS	1 ST H	2 ^N D	3 RD	4 TH	5 ^T H
S220	WELD SOP 0100 REV 7	EXCAVATE ANY DEFECTS FOUND DURING RADIOGRAPHY.	JC 4/15/05				
S230	L.P. EXCAVATION CQP-300 REV 10	L.P. ALL EXCAVATIONS PRIOR TO WELDING TO ENSURE REMOVAL OF DEFECT. ACCEPTANCE PER A903. ACCEPTANCE CRITERIA-LEVEL 1 FOR HIGH STRESSED AREAS, LEVEL 2 FOR ALL OTHER AREAS. SEE LP DRAWING.	LP - LEVE L II SB 6/15/05				
S240	WELD MAP	MAP ALL WELDS WITH DIGITAL PHOTO/MAPS INDICATING LOCATION. SERIALIZE DEFECTS ON CASTING, USE SCALE IN PHOTOS AND DOCUMENT SIZE. THIS IS TO BE PERFORMED BY SUPERVISOR, INSPECTION LEAD MAN OR THEIR DESIGNEE, FILE WITH QA. MUST SEND REPORT ON ALL WELDS OVER 10% OF NOMINAL WALL THICKNESS TO CUSTOMER. DEFECTS > 10% YES <input checked="" type="checkbox"/> , REPORT SENT BY <u>Ctn</u> DATE <u>6/15/05</u> DEFECTS < 10% _____ SIGN BY QA ENG. REPAIRS MAY NOT PROCEED UNTIL INFORMATION IS SUBMITTED.	Ctn				
NOTICE	WITNESS NOTIFICATION	PROVIDE NOTICE TO EIO AND DCMA AT LEAST FIVE DAYS IN ADVANCE OF WELD STEP. EIO NOTIFIED ON <u>6/13/05</u> DCMA NOTIFIED ON <u>6/13/05</u>	Q ENG OR QA MGR	Ctn	4/12		
S260	QA APPROVAL HOLD POINT	QA TO APPROVE ELECTRODE PRIOR TO USE. PROCEDURE USED: <u>WPS 10-SMAW-CF8MNMN MOD REV 1</u> MATERIAL USED: <u>Lot 4455</u> QUALITY ENG. Name: <u>Ctn</u> Date: <u>6/15</u> <i>Handwritten notes: 4455, Lot 4455, 316 NF, Lot 20197M</i>	Ctn	4/15			
S270	WELD SOP 0100 REV 7	<u>WELD REPAIR DEFECTS AS MARKED.</u> FOR WELDS < 2" - WPS 10-SMAW-CF8MNMN MOD REV 1 FOR WELDS < 8" - WPS 15-GMAW-CF8MNMN MOD REV 2 ADD WPS FOR VERTICAL WELDS.	JC	6-15	JC 6-23-05		
S280	GRIND GCHI SOP 0100R2	HAND GRIND WELDS.	JC	6-15	JC 6-23-05		
S290	L.P. WELD CQP 0300 REV 10	L.P. WELD REPAIRS ACCEPTANCE PER ASTM A903. ACCEPTANCE CRITERIA-LEVEL 1 FOR HIGH STRESSED AREAS, LEVEL 2 FOR ALL OTHER AREAS. SEE LP DRAWING. IF OK CHECK HERE <input checked="" type="checkbox"/> WASH AND SEND TO STEP 300. IF REJECTED CHECK HERE _____ AND RETURN TO STEP 220.	LP - LEVE L II JOK 4/15	OK REJ	OK REJ TIC 6/15	OK REJ GPR 6/15	OK REJ J

Added
lot of
welds
per Rev 1
Ctn

all grind
of LP ind
Ctn

to XRAY 6/16

	REPEAT	REPEAT STEPS S220 TO S290 AS REQUIRED TILL CLEAR THROUGH VISUAL INSPECTION & PENETRANT INSPECTION. DOCUMENT REWORK ON A SUPPLEMENTAL MTS	GA	4/23	90	40	460		

NOTES: Stress relieve of C-2 Coil Casting

C-2 Doc Package
Document # 24

SUPPLEMENTAL ROUTING CARD

Date: 6-20-05

PART NUMBER: C-2 Coil

SERIAL NUMBER: C-1

AUTHORITY
C Ruud

OPER
NUMBER

STATION

OPERATOR
SIGN/DATE

Extra
operation

Heat treat

Load casting into cold furnace. Ramp up to 1100 F at rate of 200 F per hour. Hold at temp 4-5 hours. Furnace cool to 500 F at 50 F per hour. Air cool. Submit furnace charts to QA.

DLS
FS-1 6-21-05

Qualify Report

C-2 Doc Package
Document # 25

Date Generated: 5/22/2005, 11:49 am

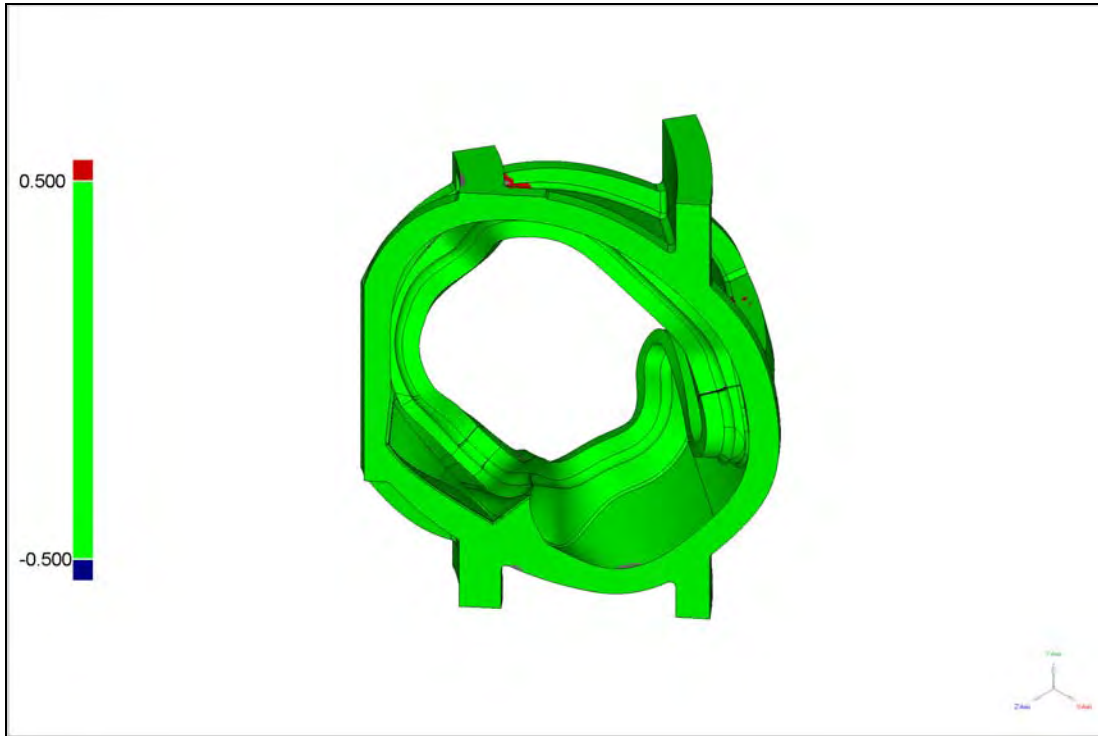

Author: Kevin Harris / Jarrod Boyer

Part: C2

Test: Merged Points 1

Annotated: Annotation View Top

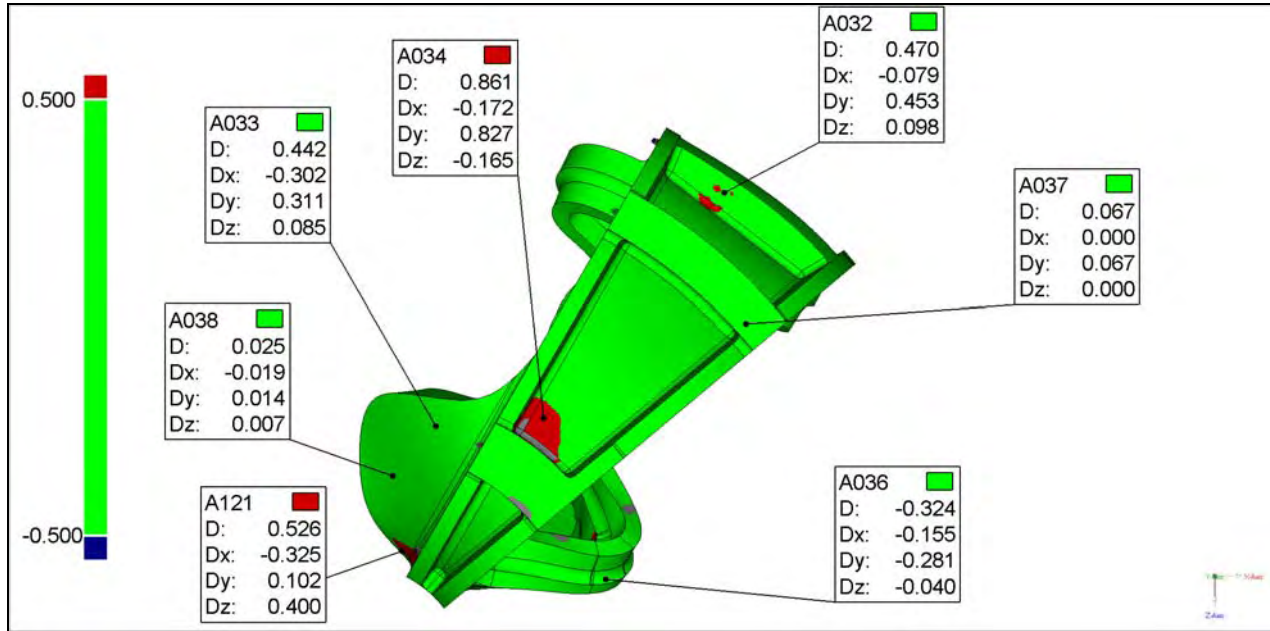

Units: in

Name	Dev	Status	Tol +	Tol -	Ref X	Ref Y	Ref Z	Dev Radius	Dev X	Dev Y	Dev Z	Test X	Test Y	Test Z
A032	0.470	FAIL	0.100	-0.100	54.294	11.519	-71.235	0.039	-0.079	0.453	0.098	54.215	11.972	-71.137
A033	0.442	FAIL	0.100	-0.100	11.899	30.670	-36.884	0.039	-0.302	0.311	0.085	11.597	30.981	-36.798
A034	0.861	FAIL	0.100	-0.100	27.749	40.157	-38.073	0.039	-0.172	0.827	-0.165	27.577	40.984	-38.237
A036	-0.324	FAIL	0.100	-0.100	36.863	-3.808	-14.297	0.039	-0.155	-0.281	-0.040	36.708	-4.090	-14.337
A037	0.067	PASS	0.100	-0.100	57.469	48.188	-51.942	0.039	0.000	0.067	0.000	57.469	48.255	-51.942
A038	0.025	PASS	0.100	-0.100	5.558	19.704	-29.553	0.039	-0.019	0.014	0.007	5.539	19.718	-29.546
A121	0.526	FAIL	0.100	-0.100	6.945	8.741	-18.458	0.039	-0.325	0.102	0.400	6.620	8.843	-18.057

Annotated: Annotation View Bottom

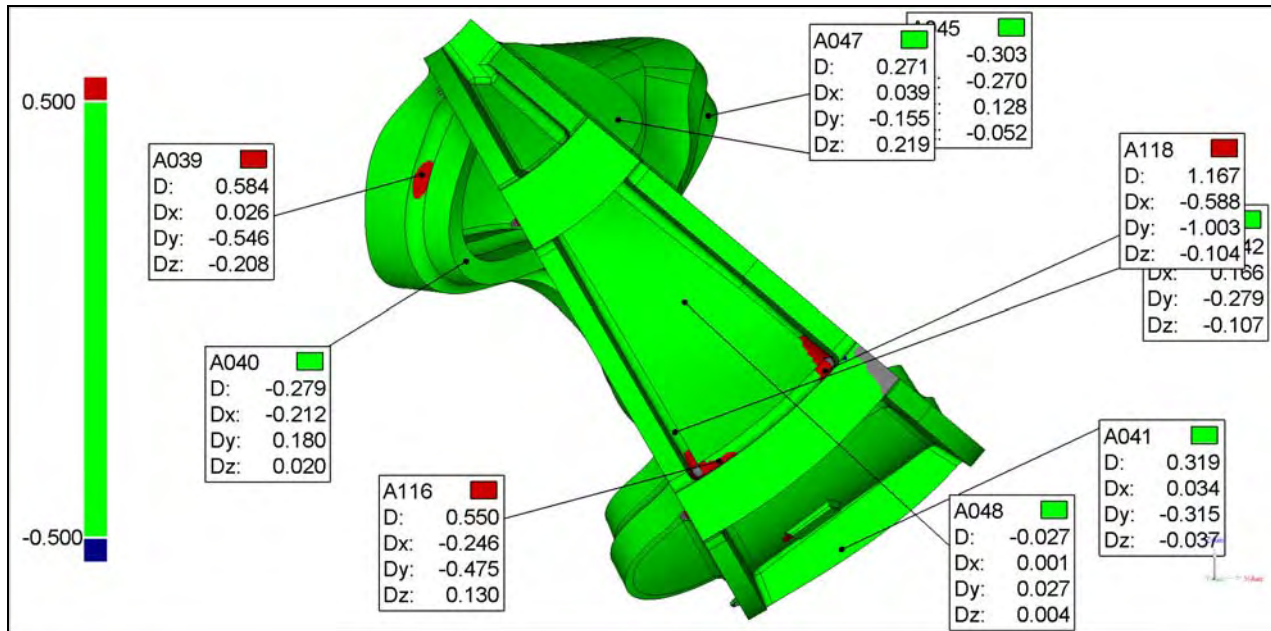

Units: in

Name	Dev	Status	Tol +	Tol -	Ref X	Ref Y	Ref Z	Dev Radius	Dev X	Dev Y	Dev Z	Test X	Test Y	Test Z
A039	0.584	FAIL	0.100	-0.100	7.399	10.856	-28.360	0.039	0.026	-0.546	-0.208	7.425	10.310	-28.567
A040	-0.279	FAIL	0.100	-0.100	12.590	14.051	-38.580	0.039	-0.212	0.180	0.020	12.377	14.230	-38.560
A041	0.319	FAIL	0.100	-0.100	56.713	6.078	-72.483	0.039	0.034	-0.315	-0.037	56.747	5.762	-72.520
A044	0.342	FAIL	0.100	-0.100	37.135	-31.757	-58.654	0.039	0.166	-0.279	-0.107	37.301	-32.037	-58.761
A045	-0.303	FAIL	0.100	-0.100	41.032	-8.625	-21.418	0.039	-0.270	0.128	-0.052	40.762	-8.497	-21.469
A047	0.271	FAIL	0.100	-0.100	30.470	-23.402	-21.884	0.039	0.039	-0.155	0.219	30.509	-23.558	-21.665
A048	-0.027	PASS	0.100	-0.100	38.270	-38.262	-43.393	0.039	0.001	0.027	0.004	38.270	-38.235	-43.390
A116	0.550	FAIL	0.100	-0.100	42.288	-28.727	-62.067	0.039	-0.246	-0.475	0.130	42.042	-29.202	-61.937
A118	1.167	FAIL	0.100	-0.100	54.773	-33.113	-51.430	0.039	-0.588	-1.003	-0.104	54.185	-34.115	-51.534

Annotated: Annotation View Left

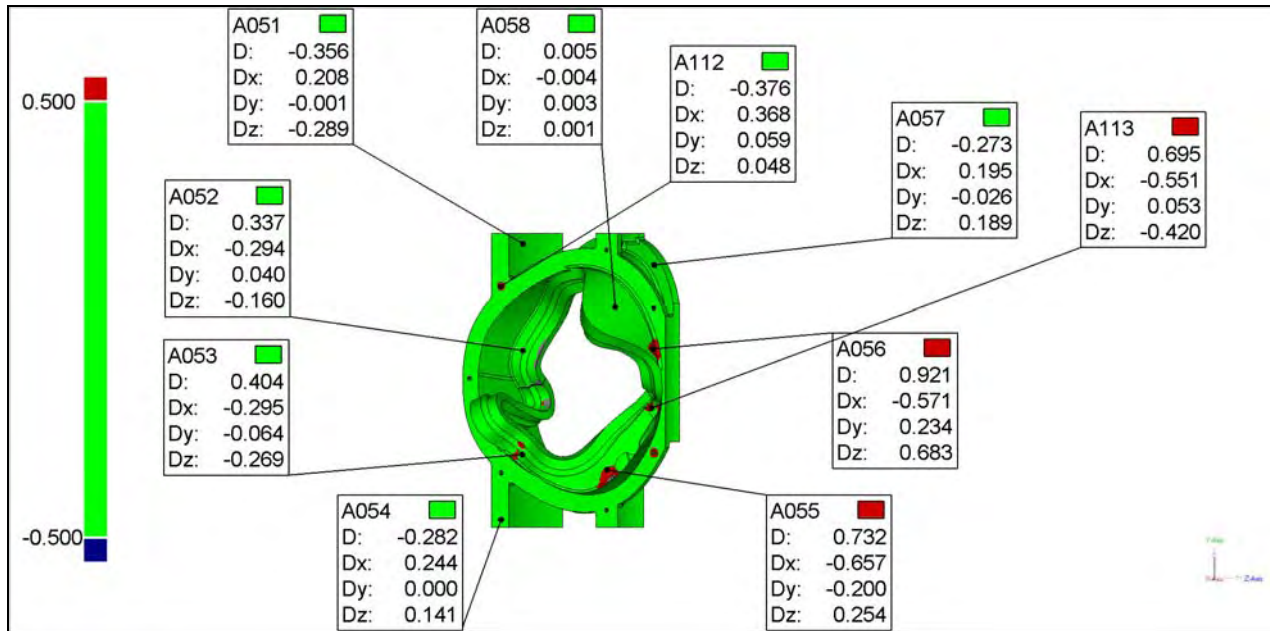

Units: in

Name	Dev	Status	Tol +	Tol -	Ref X	Ref Y	Ref Z	Dev Radius	Dev X	Dev Y	Dev Z	Test X	Test Y	Test Z
A051	-0.356	FAIL	0.100	-0.100	44.544	44.812	-61.169	0.039	0.208	-0.001	-0.289	44.752	44.811	-61.458
A052	0.337	FAIL	0.100	-0.100	53.352	9.964	-61.169	0.039	-0.294	0.040	-0.160	53.058	10.004	-61.329
A053	0.404	FAIL	0.100	-0.100	36.665	-24.158	-61.411	0.039	-0.295	-0.064	-0.269	36.371	-24.222	-61.680
A054	-0.282	FAIL	0.100	-0.100	38.553	-45.608	-68.276	0.039	0.244	0.000	0.141	38.798	-45.608	-68.135
A055	0.732	FAIL	0.100	-0.100	32.132	-29.208	-33.635	0.039	-0.657	-0.200	0.254	31.476	-29.408	-33.381
A056	0.921	FAIL	0.100	-0.100	7.357	10.477	-18.642	0.039	-0.571	0.234	0.683	6.786	10.711	-17.959
A057	-0.273	FAIL	0.100	-0.100	18.242	37.816	-18.201	0.039	0.195	-0.026	0.189	18.437	37.790	-18.012
A058	0.005	PASS	0.100	-0.100	8.213	24.147	-30.989	0.039	-0.004	0.003	0.001	8.209	24.149	-30.988
A112	-0.376	FAIL	0.100	-0.100	37.662	30.761	-68.470	0.039	0.368	0.059	0.048	38.030	30.820	-68.421
A113	0.695	FAIL	0.100	-0.100	34.410	-8.925	-19.083	0.039	-0.551	0.053	-0.420	33.859	-8.871	-19.503

Annotated: Annotation View Right

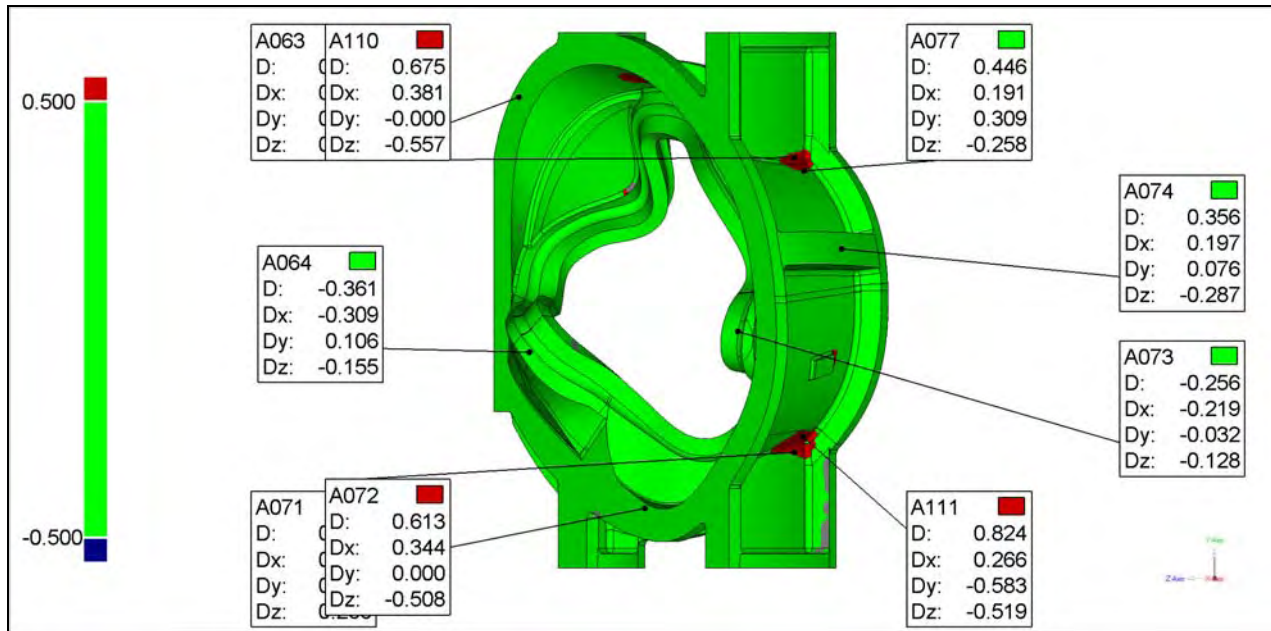

Units: in

Name	Dev	Status	Tol +	Tol -	Ref X	Ref Y	Ref Z	Dev Radius	Dev X	Dev Y	Dev Z	Test X	Test Y	Test Z
A063	0.379	FAIL	0.100	-0.100	18.531	36.560	-14.571	0.039	0.244	0.000	0.290	18.775	36.560	-14.280
A064	-0.361	FAIL	0.100	-0.100	40.476	-9.285	-16.439	0.039	-0.309	0.106	-0.155	40.167	-9.179	-16.594
A071	0.348	FAIL	0.100	-0.100	45.441	-37.411	-37.150	0.039	0.223	0.000	0.266	45.664	-37.411	-36.884
A072	0.613	FAIL	0.100	-0.100	43.968	-27.330	-64.018	0.039	0.344	0.000	-0.508	44.312	-27.330	-64.526
A073	-0.256	FAIL	0.100	-0.100	65.593	-5.551	-53.854	0.039	-0.219	-0.032	-0.128	65.374	-5.583	-53.983
A074	0.356	FAIL	0.100	-0.100	57.859	9.211	-72.488	0.039	0.197	0.076	-0.287	58.056	9.287	-72.775
A077	0.446	FAIL	0.100	-0.100	44.242	23.247	-65.712	0.039	0.191	0.309	-0.258	44.433	23.557	-65.970
A110	0.675	FAIL	0.100	-0.100	43.968	25.667	-64.018	0.039	0.381	-0.000	-0.557	44.349	25.667	-64.575
A111	0.824	FAIL	0.100	-0.100	44.012	-24.426	-65.470	0.039	0.266	-0.583	-0.519	44.278	-25.010	-65.989

Annotated: Annotation View Front

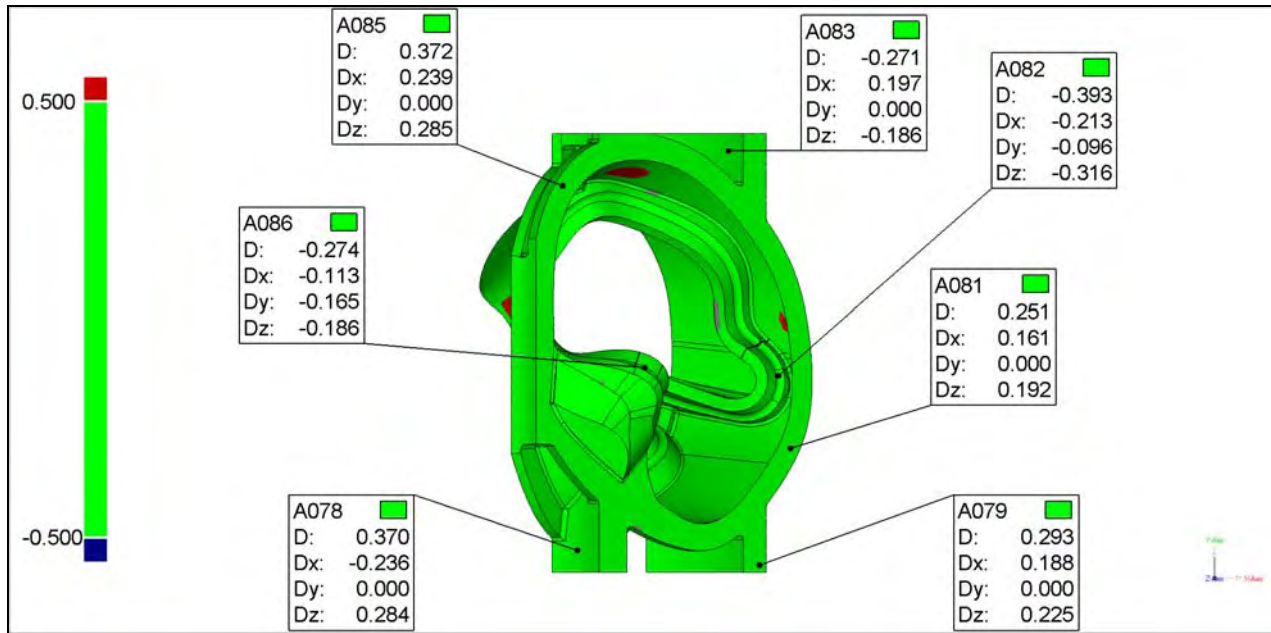

Units: in

Name	Dev	Status	Tol +	Tol -	Ref X	Ref Y	Ref Z	Dev Radius	Dev X	Dev Y	Dev Z	Test X	Test Y	Test Z
A078	0.370	FAIL	0.100	-0.100	22.125	-43.372	-26.471	0.039	-0.236	0.000	0.284	21.889	-43.372	-26.187
A079	0.293	FAIL	0.100	-0.100	62.028	-46.623	-51.069	0.039	0.188	0.000	0.225	62.216	-46.623	-50.844
A081	0.251	FAIL	0.100	-0.100	68.826	-20.908	-56.773	0.039	0.161	0.000	0.192	68.987	-20.908	-56.581
A082	-0.393	FAIL	0.100	-0.100	66.166	-4.946	-54.617	0.039	-0.213	-0.096	-0.316	65.953	-5.043	-54.932
A083	-0.271	FAIL	0.100	-0.100	55.230	44.415	-51.785	0.039	0.197	0.000	-0.186	55.427	44.415	-51.971
A085	0.372	FAIL	0.100	-0.100	18.874	36.730	-14.858	0.039	0.239	0.000	0.285	19.113	36.730	-14.573
A086	-0.274	FAIL	0.100	-0.100	36.904	-3.173	-15.496	0.039	-0.113	-0.165	-0.186	36.791	-3.338	-15.682

Annotated: Annotation View Back

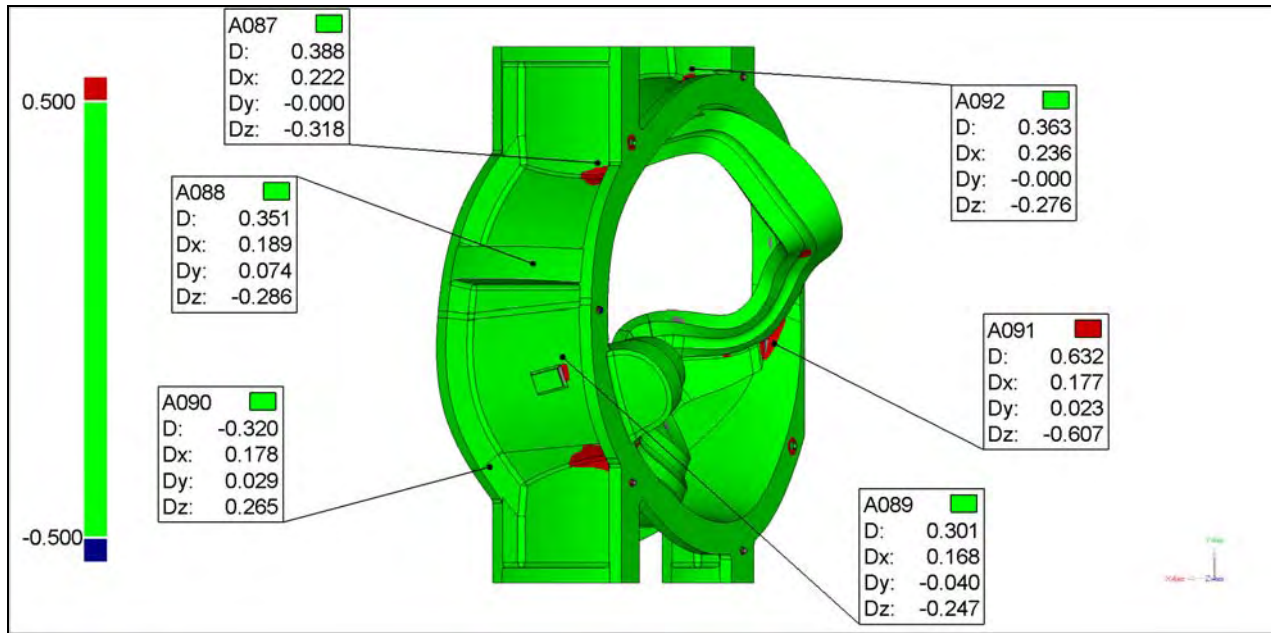

Units: in

Name	Dev	Status	Tol +	Tol -	Ref X	Ref Y	Ref Z	Dev Radius	Dev X	Dev Y	Dev Z	Test X	Test Y	Test Z
A087	0.388	FAIL	0.100	-0.100	44.656	27.300	-63.543	0.039	0.222	-0.000	-0.318	44.878	27.300	-63.861
A088	0.351	FAIL	0.100	-0.100	56.271	9.151	-73.572	0.039	0.189	0.074	-0.286	56.460	9.225	-73.859
A089	0.301	FAIL	0.100	-0.100	50.948	-7.547	-71.367	0.039	0.168	-0.040	-0.247	51.115	-7.587	-71.614
A090	-0.320	FAIL	0.100	-0.100	64.015	-27.391	-56.486	0.039	0.178	0.029	0.265	64.193	-27.363	-56.221
A091	0.632	FAIL	0.100	-0.100	12.954	-5.127	-14.409	0.039	0.177	0.023	-0.607	13.131	-5.105	-15.016
A092	0.363	FAIL	0.100	-0.100	27.716	44.240	-32.733	0.039	0.236	-0.000	-0.276	27.952	44.240	-33.009

Annotated: Annotation View Isometric

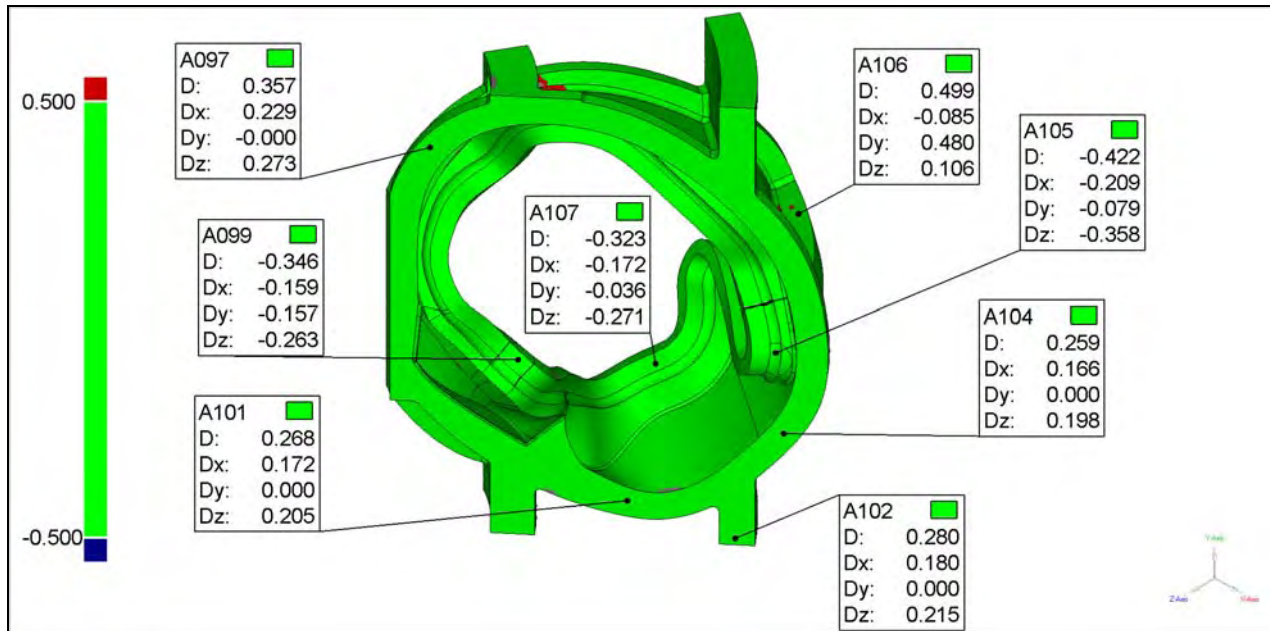

Units: in

Name	Dev	Status	Tol +	Tol -	Ref X	Ref Y	Ref Z	Dev Radius	Dev X	Dev Y	Dev Z	Test X	Test Y	Test Z
A097	0.357	FAIL	0.100	-0.100	18.638	35.973	-14.660	0.039	0.229	-0.000	0.273	18.868	35.973	-14.387
A099	-0.346	FAIL	0.100	-0.100	38.499	-2.006	-17.121	0.039	-0.159	-0.157	-0.263	38.340	-2.164	-17.385
A101	0.268	FAIL	0.100	-0.100	45.849	-39.638	-37.493	0.039	0.172	0.000	0.205	46.021	-39.638	-37.288
A102	0.280	FAIL	0.100	-0.100	60.736	-46.739	-49.985	0.039	0.180	0.000	0.215	60.917	-46.739	-49.770
A104	0.259	FAIL	0.100	-0.100	67.436	-23.082	-55.606	0.039	0.166	0.000	0.198	67.602	-23.082	-55.408
A105	-0.422	FAIL	0.100	-0.100	66.355	-5.353	-54.634	0.039	-0.209	-0.079	-0.358	66.146	-5.431	-54.992
A106	0.499	FAIL	0.100	-0.100	55.821	11.733	-70.985	0.039	-0.085	0.480	0.106	55.736	12.213	-70.879
A107	-0.323	FAIL	0.100	-0.100	35.687	-23.162	-54.842	0.039	-0.172	-0.036	-0.271	35.515	-23.198	-55.113

Qualify Report

C-2 Doc Package
Document # 25a

Date Generated: 5/23/2005, 5:05 pm

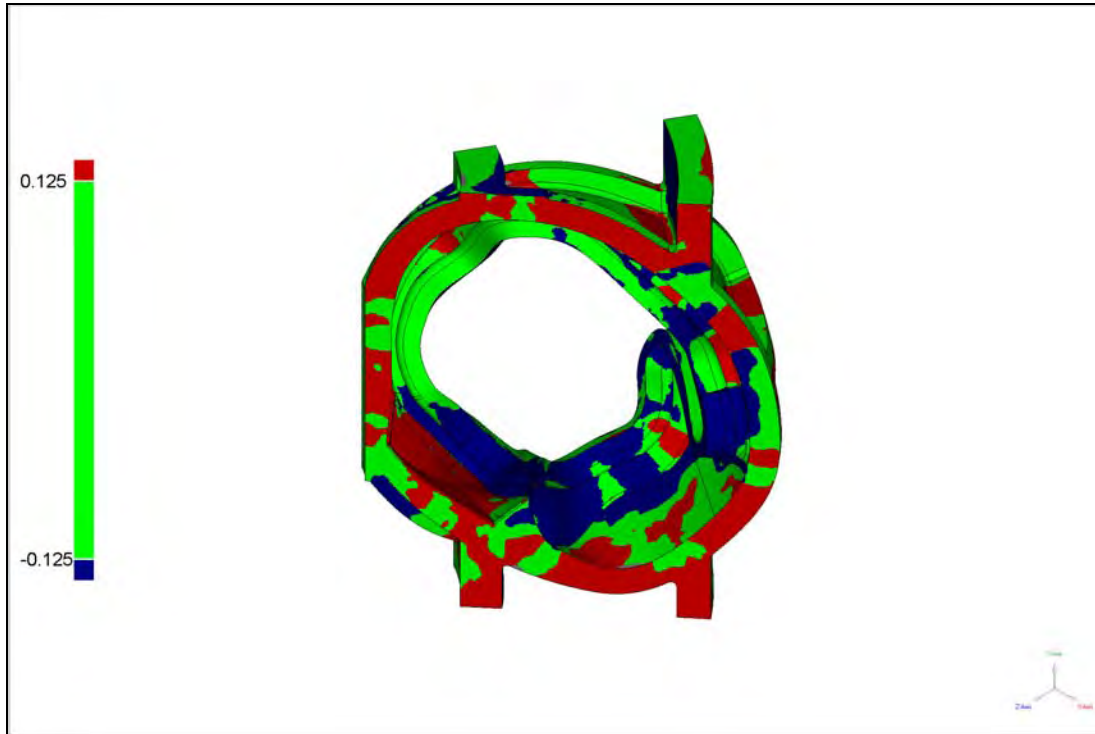

Author: Kevin Harris / Jarrod Boyer

Part: C2

Test: Merged Points 1

3D Comparison Results

Reference Model	c-coil-casting
Test Model	Merged Points 1
# Data Points	5326043

Tolerances	in
Max Tol +	0.125
Min Tol +	0.125
Min Tol -	-0.125
Max Tol -	-0.125

Deviation	in
Max Dev +	2.048
Max Dev -	-2.060
Average +/-	0.132 / -0.115
Std Dev	0.172

Percentage Deviations

>=Min	<Max	# Points	%
-0.125	0.125	3257136	61.155

Out of Max Tol +	1067561	20.044
Out of Max Tol -	1001346	18.801

Standard Deviations

Distribution ()	# Points	%
-6 * Std Dev	38	0.001
-5 * Std Dev	384	0.007
-4 * Std Dev	674	0.013
-3 * Std Dev	2880	0.054
-2 * Std Dev	201623	3.786
-1 * Std Dev	1206953	22.661
1 * Std Dev	2451060	46.020
2 * Std Dev	1137309	21.354
3 * Std Dev	230395	4.326
4 * Std Dev	52331	0.983
5 * Std Dev	20317	0.381
6 * Std Dev	12930	0.243

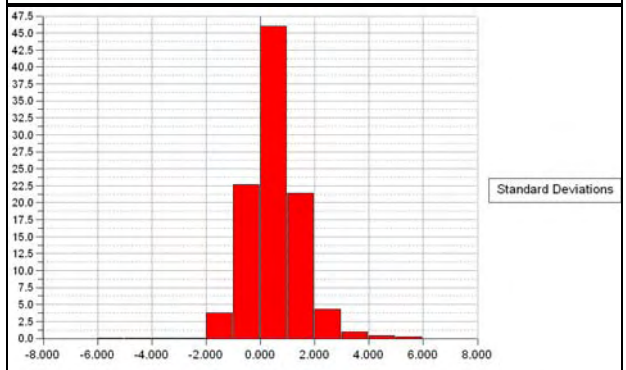
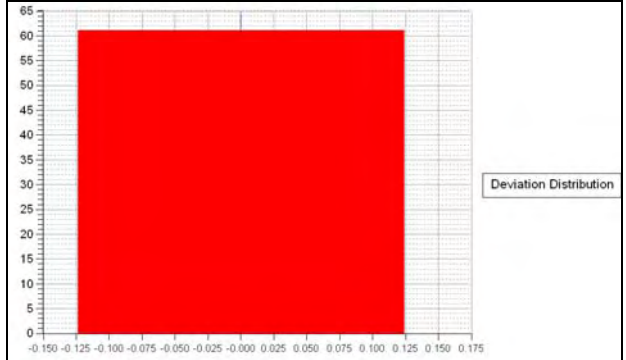
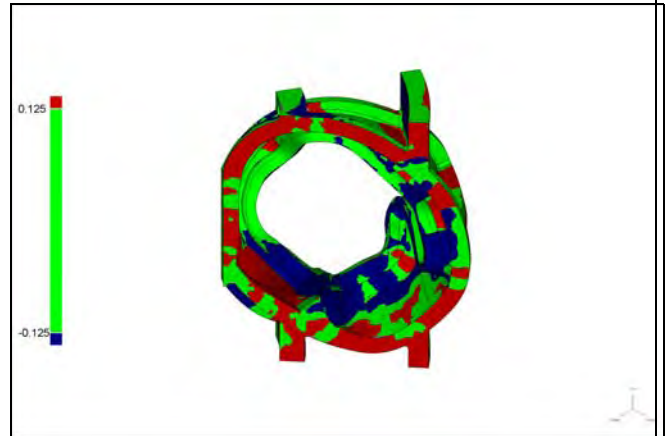

Predefined: Front

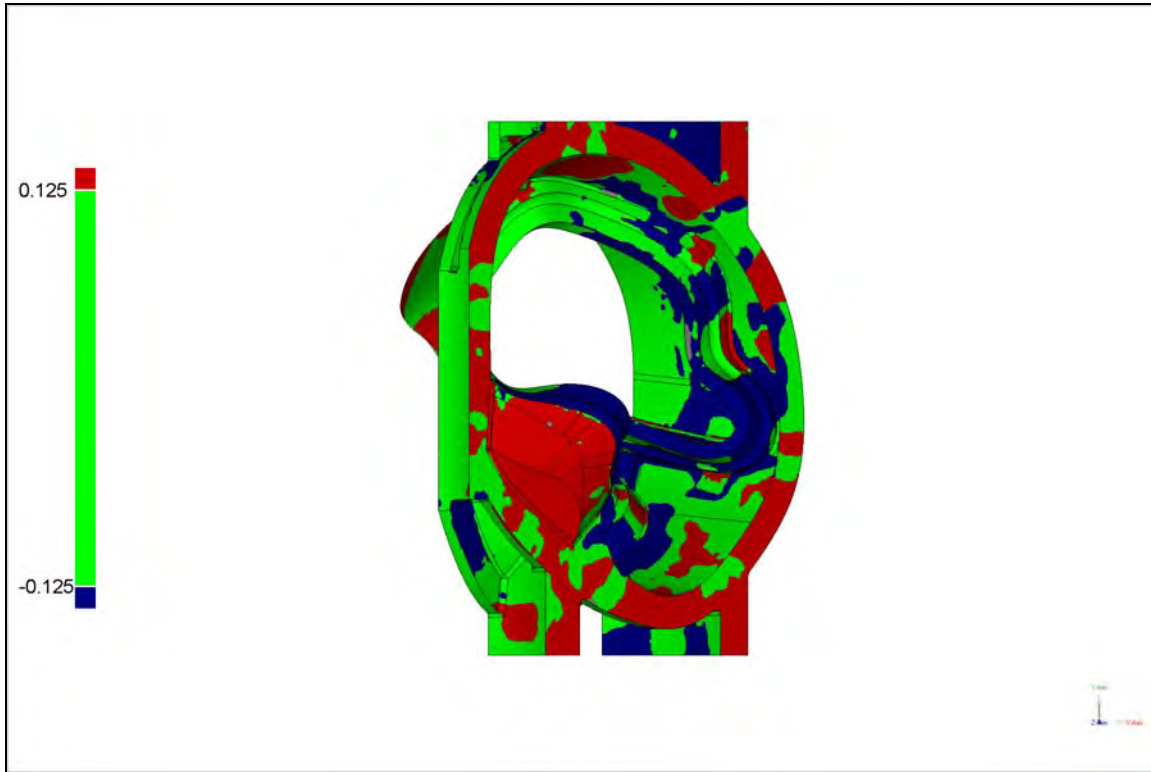

Predefined: Back

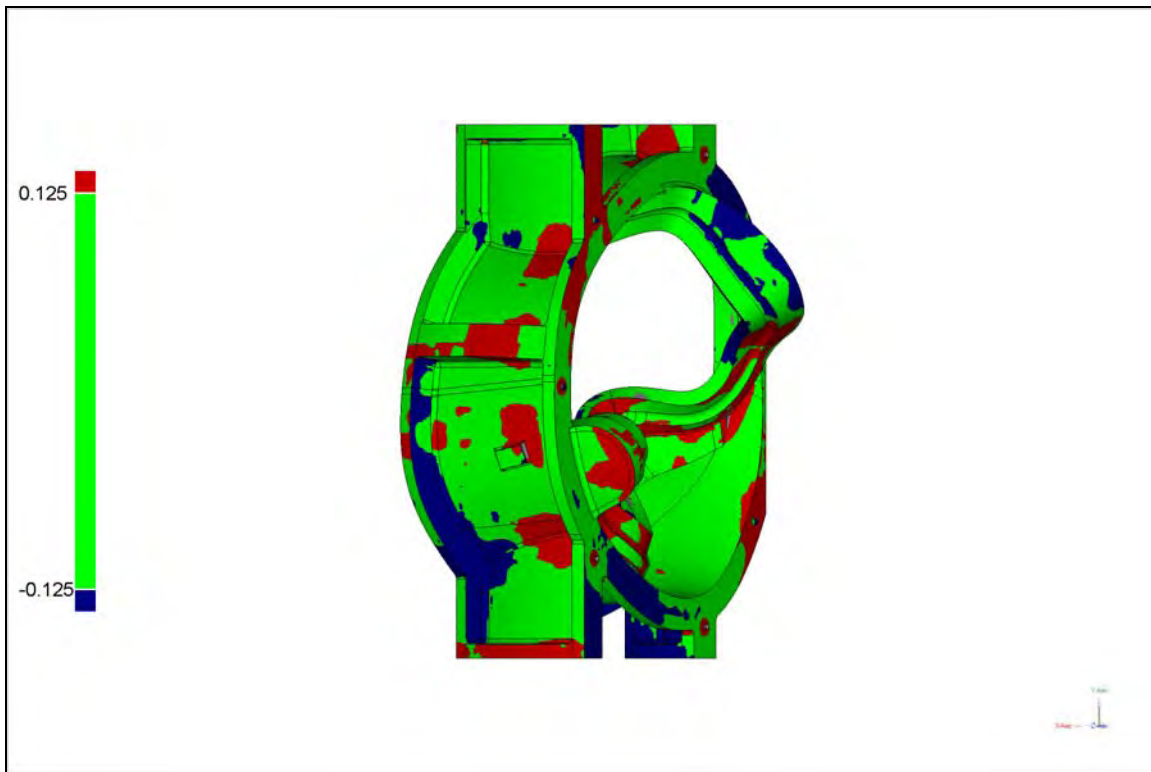

Predefined: Left

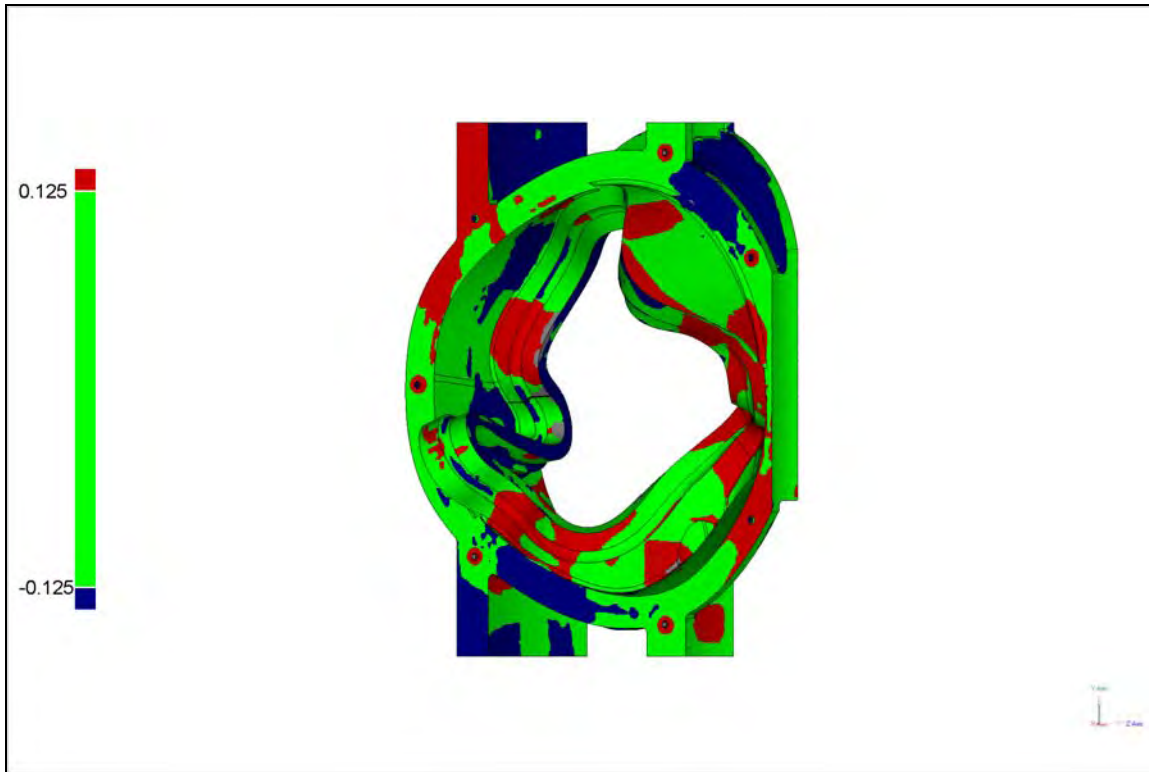

Predefined: Right

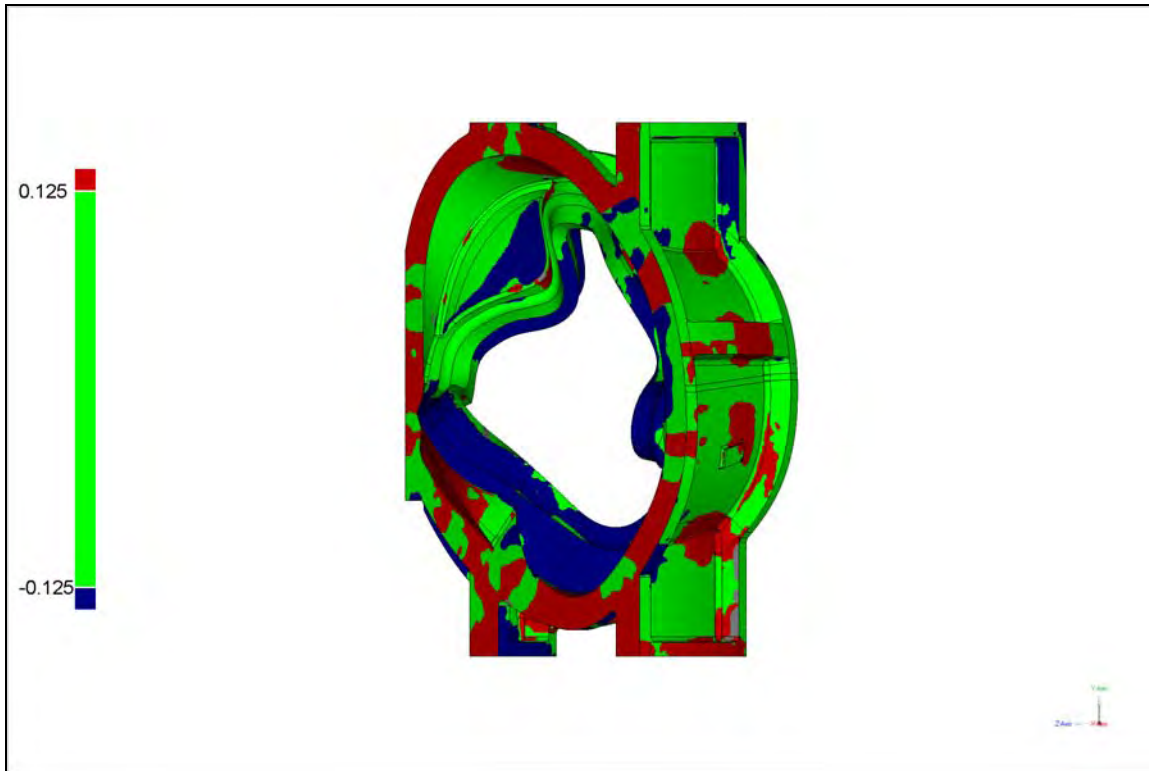

Predefined: Top

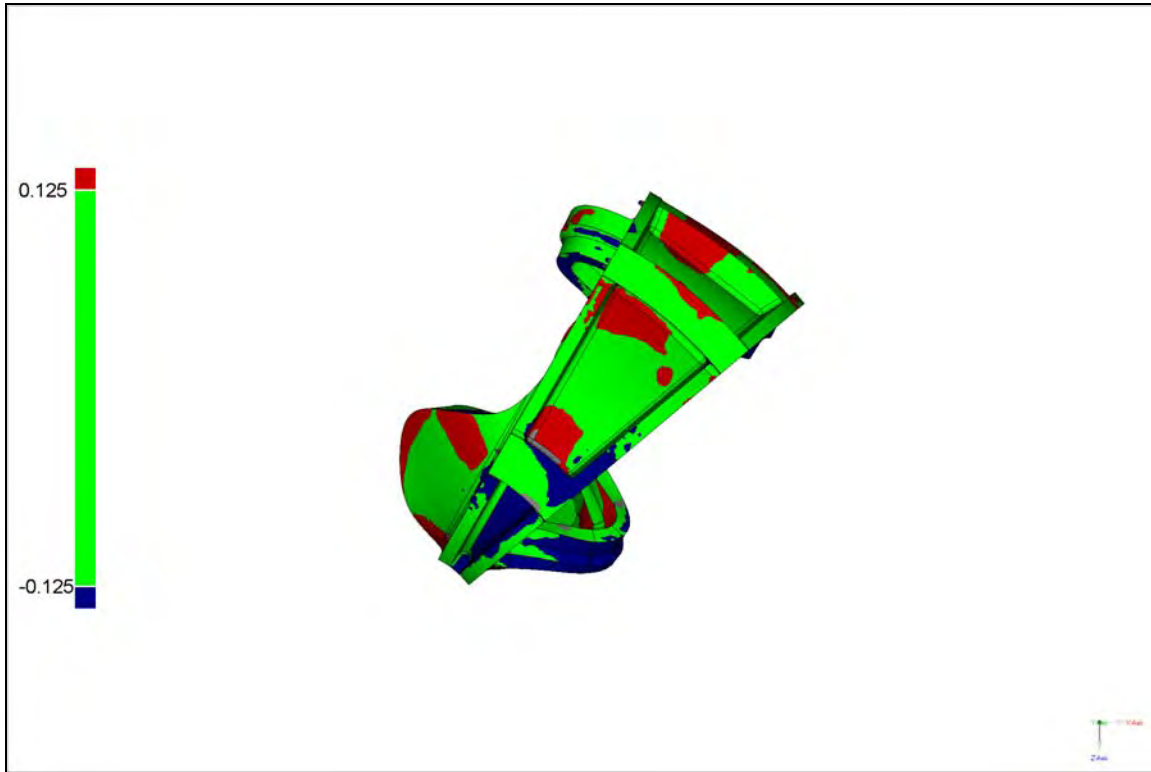

Predefined: Bottom

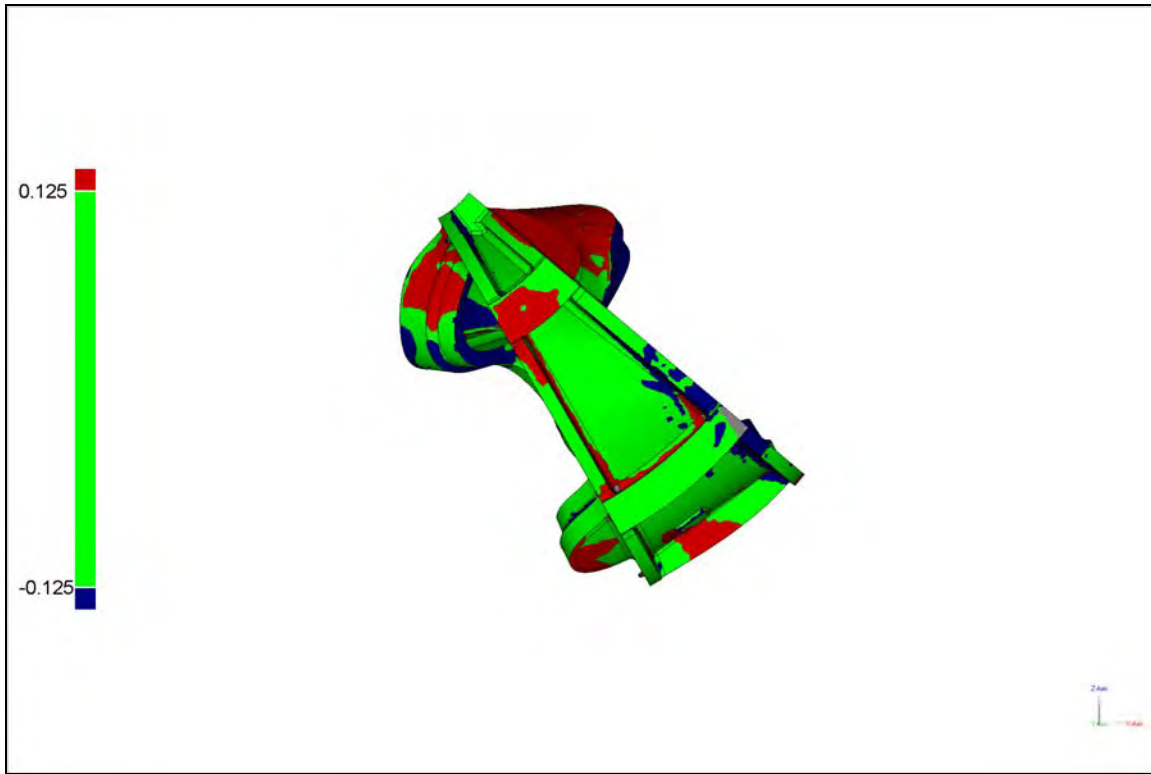

Predefined: Isometric

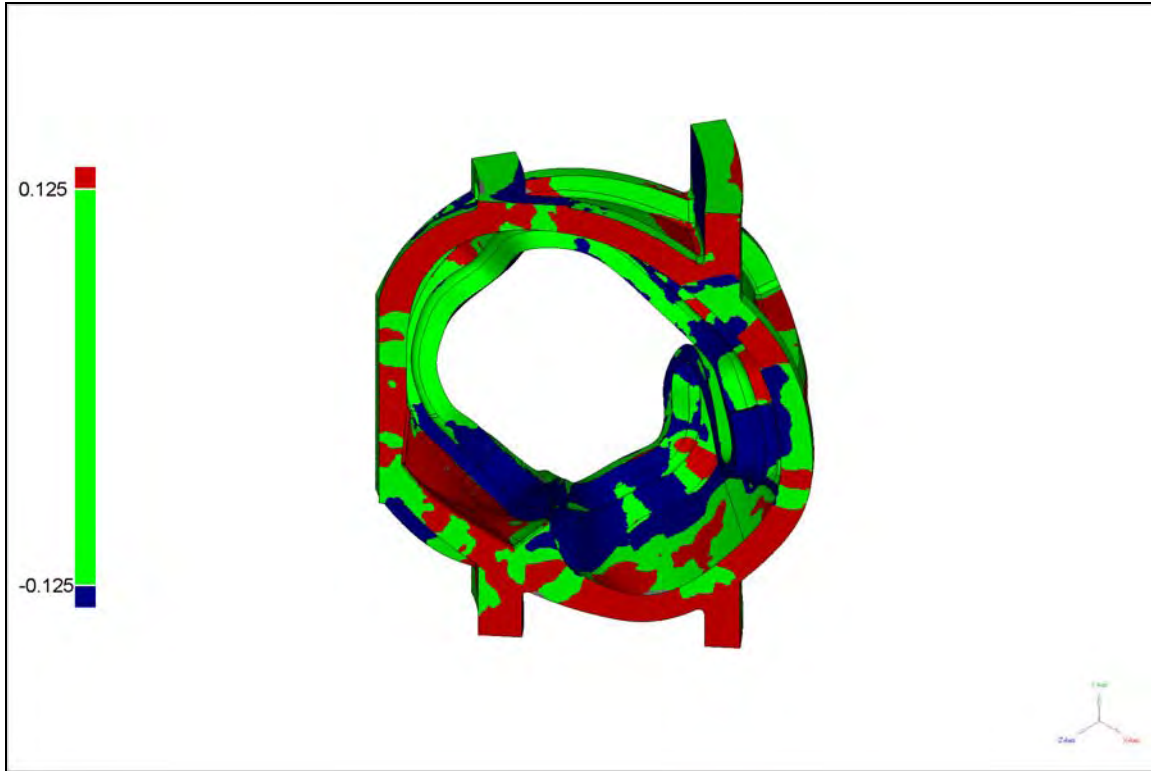

Annotated: Annotation View Top

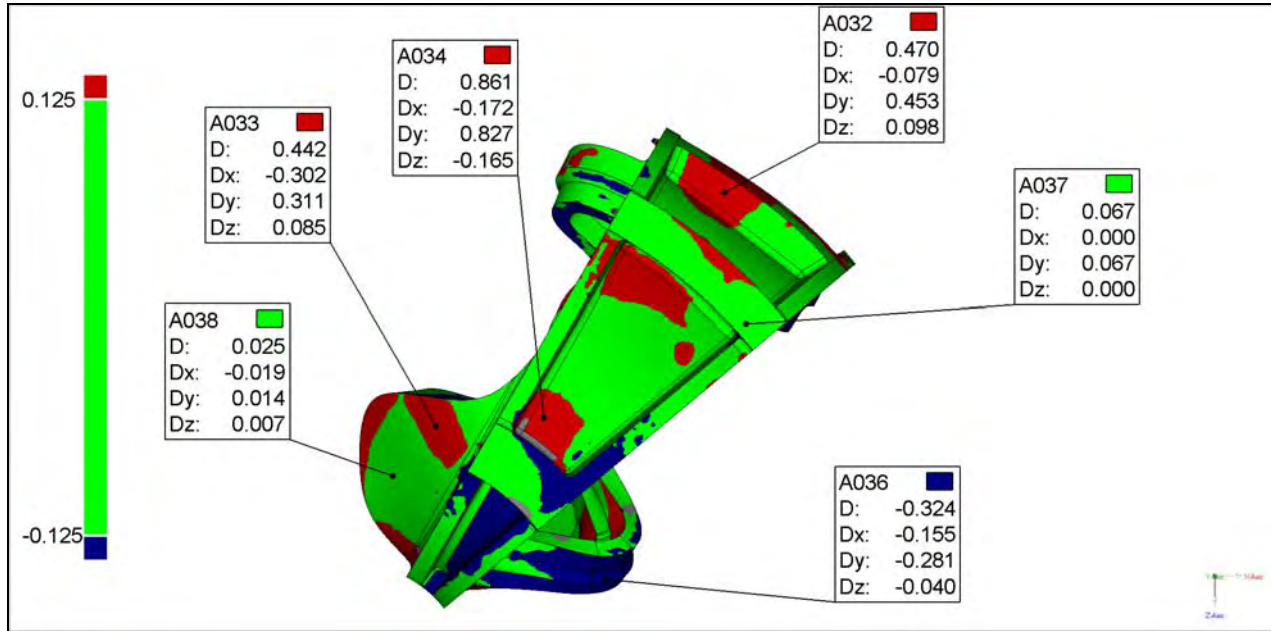

Units: in

Name	Dev	Status	Tol +	Tol -	Ref X	Ref Y	Ref Z	Dev Radius	Dev X	Dev Y	Dev Z	Test X	Test Y	Test Z
A032	0.470	FAIL	0.100	-0.100	54.294	11.519	-71.235	0.039	-0.079	0.453	0.098	54.215	11.972	-71.137
A033	0.442	FAIL	0.100	-0.100	11.899	30.670	-36.884	0.039	-0.302	0.311	0.085	11.597	30.981	-36.798
A034	0.861	FAIL	0.100	-0.100	27.749	40.157	-38.073	0.039	-0.172	0.827	-0.165	27.577	40.984	-38.237
A036	-0.324	FAIL	0.100	-0.100	36.863	-3.808	-14.297	0.039	-0.155	-0.281	-0.040	36.708	-4.090	-14.337
A037	0.067	PASS	0.100	-0.100	57.469	48.188	-51.942	0.039	0.000	0.067	0.000	57.469	48.255	-51.942
A038	0.025	PASS	0.100	-0.100	5.558	19.704	-29.553	0.039	-0.019	0.014	0.007	5.539	19.718	-29.546

Annotated: Annotation View Bottom

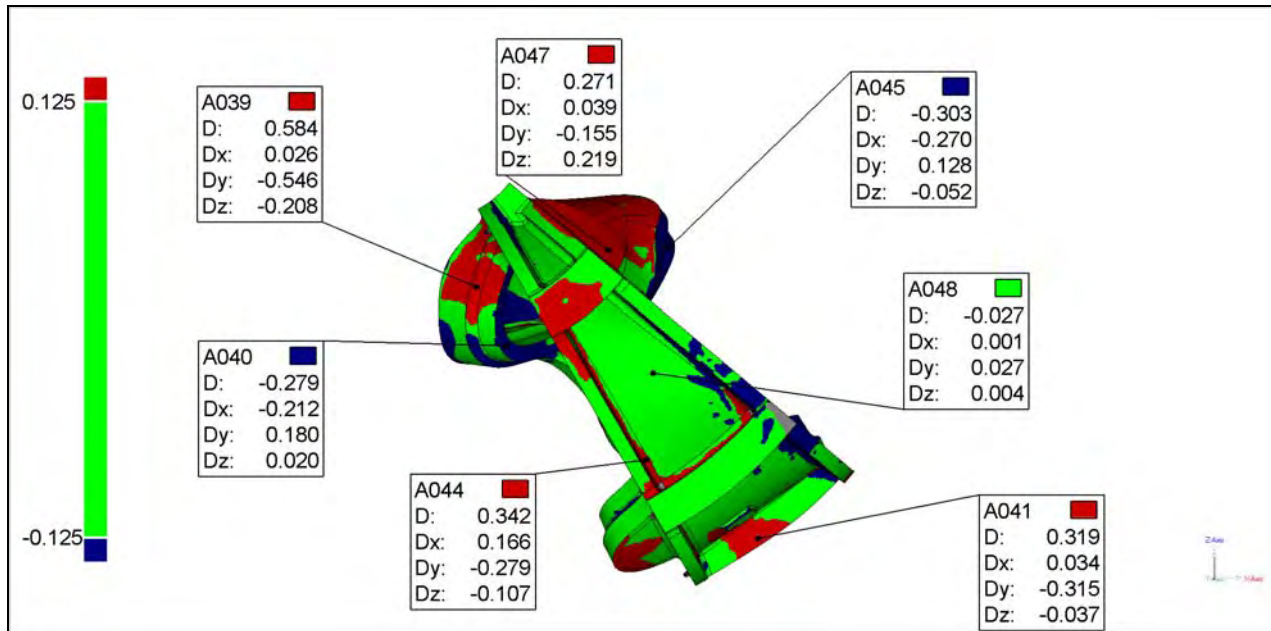

Units: in

Name	Dev	Status	Tol +	Tol -	Ref X	Ref Y	Ref Z	Dev Radius	Dev X	Dev Y	Dev Z	Test X	Test Y	Test Z
A039	0.584	FAIL	0.100	-0.100	7.399	10.856	-28.360	0.039	0.026	-0.546	-0.208	7.425	10.310	-28.567
A040	-0.279	FAIL	0.100	-0.100	12.590	14.051	-38.580	0.039	-0.212	0.180	0.020	12.377	14.230	-38.560
A041	0.319	FAIL	0.100	-0.100	56.713	6.078	-72.483	0.039	0.034	-0.315	-0.037	56.747	5.762	-72.520
A044	0.342	FAIL	0.100	-0.100	37.135	-31.757	-58.654	0.039	0.166	-0.279	-0.107	37.301	-32.037	-58.761
A045	-0.303	FAIL	0.100	-0.100	41.032	-8.625	-21.418	0.039	-0.270	0.128	-0.052	40.762	-8.497	-21.469
A047	0.271	FAIL	0.100	-0.100	30.470	-23.402	-21.884	0.039	0.039	-0.155	0.219	30.509	-23.558	-21.665
A048	-0.027	PASS	0.100	-0.100	38.270	-38.262	-43.393	0.039	0.001	0.027	0.004	38.270	-38.235	-43.390

Annotated: Annotation View Left

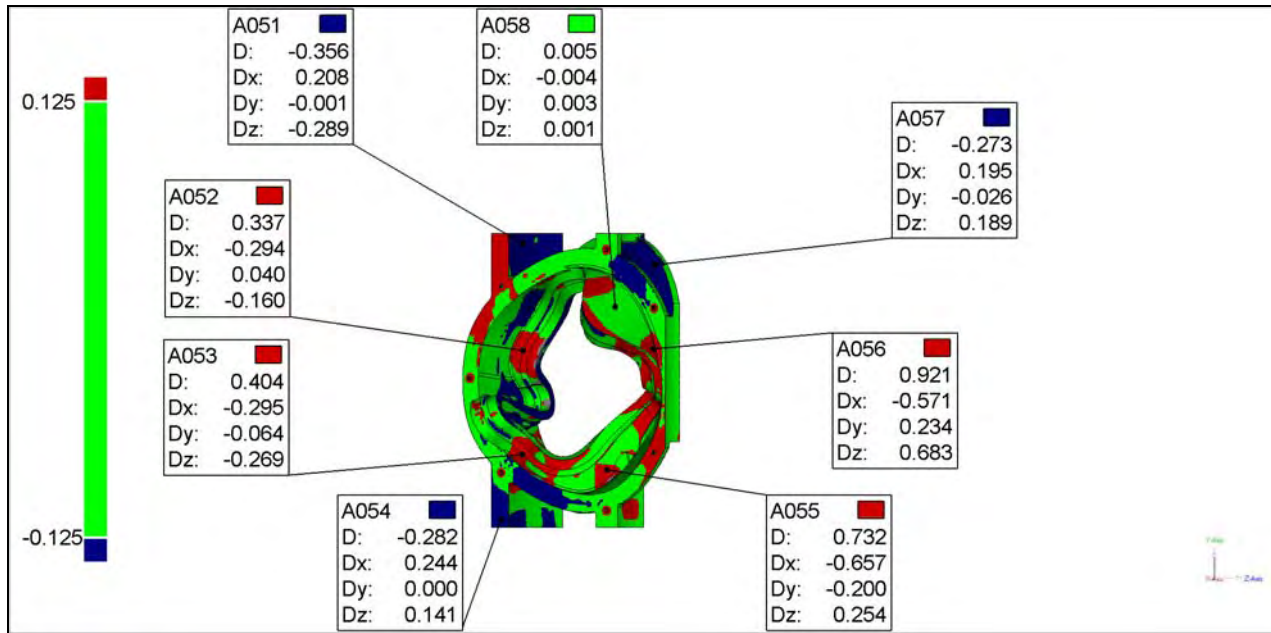

Units: in

Name	Dev	Status	Tol +	Tol -	Ref X	Ref Y	Ref Z	Dev Radius	Dev X	Dev Y	Dev Z	Test X	Test Y	Test Z
A051	-0.356	FAIL	0.100	-0.100	44.544	44.812	-61.169	0.039	0.208	-0.001	-0.289	44.752	44.811	-61.458
A052	0.337	FAIL	0.100	-0.100	53.352	9.964	-61.169	0.039	-0.294	0.040	-0.160	53.058	10.004	-61.329
A053	0.404	FAIL	0.100	-0.100	36.665	-24.158	-61.411	0.039	-0.295	-0.064	-0.269	36.371	-24.222	-61.680
A054	-0.282	FAIL	0.100	-0.100	38.553	-45.608	-68.276	0.039	0.244	0.000	0.141	38.798	-45.608	-68.135
A055	0.732	FAIL	0.100	-0.100	32.132	-29.208	-33.635	0.039	-0.657	-0.200	0.254	31.476	-29.408	-33.381
A056	0.921	FAIL	0.100	-0.100	7.357	10.477	-18.642	0.039	-0.571	0.234	0.683	6.786	10.711	-17.959
A057	-0.273	FAIL	0.100	-0.100	18.242	37.816	-18.201	0.039	0.195	-0.026	0.189	18.437	37.790	-18.012
A058	0.005	PASS	0.100	-0.100	8.213	24.147	-30.989	0.039	-0.004	0.003	0.001	8.209	24.149	-30.988

Annotated: Annotation View Right

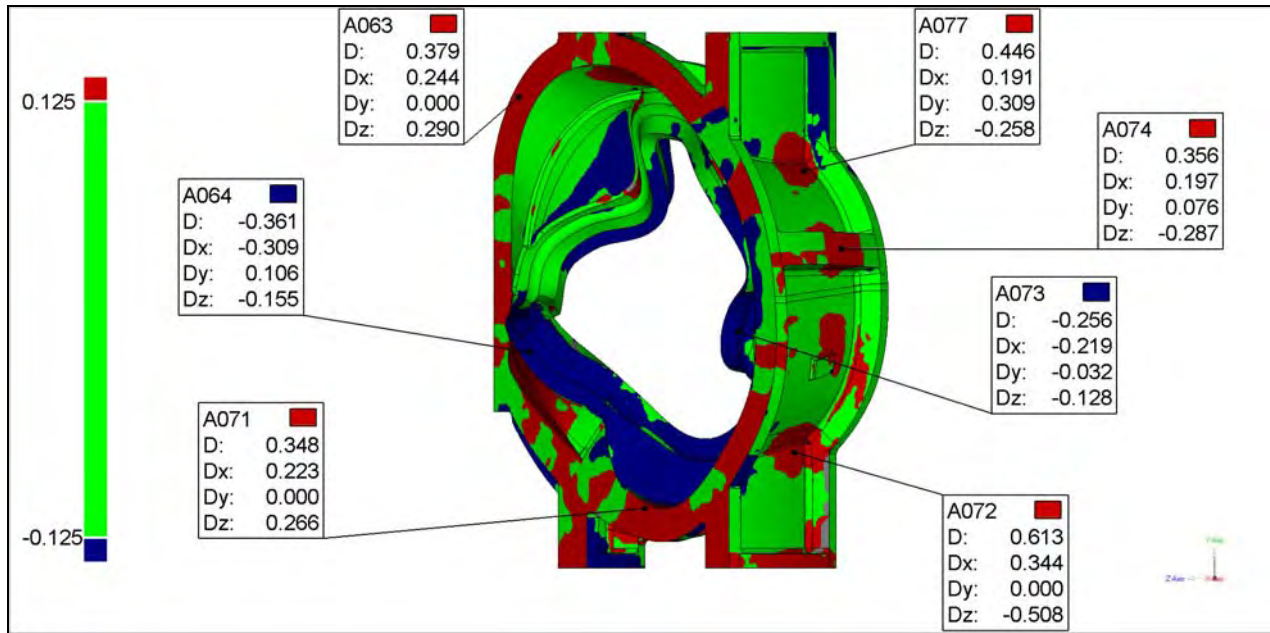

Units: in

Name	Dev	Status	Tol +	Tol -	Ref X	Ref Y	Ref Z	Dev Radius	Dev X	Dev Y	Dev Z	Test X	Test Y	Test Z
A063	0.379	FAIL	0.100	-0.100	18.531	36.560	-14.571	0.039	0.244	0.000	0.290	18.775	36.560	-14.280
A064	-0.361	FAIL	0.100	-0.100	40.476	-9.285	-16.439	0.039	-0.309	0.106	-0.155	40.167	-9.179	-16.594
A071	0.348	FAIL	0.100	-0.100	45.441	-37.411	-37.150	0.039	0.223	0.000	0.266	45.664	-37.411	-36.884
A072	0.613	FAIL	0.100	-0.100	43.968	-27.330	-64.018	0.039	0.344	0.000	-0.508	44.312	-27.330	-64.526
A073	-0.256	FAIL	0.100	-0.100	65.593	-5.551	-53.854	0.039	-0.219	-0.032	-0.128	65.374	-5.583	-53.983
A074	0.356	FAIL	0.100	-0.100	57.859	9.211	-72.488	0.039	0.197	0.076	-0.287	58.056	9.287	-72.775
A077	0.446	FAIL	0.100	-0.100	44.242	23.247	-65.712	0.039	0.191	0.309	-0.258	44.433	23.557	-65.970

Annotated: Annotation View Front

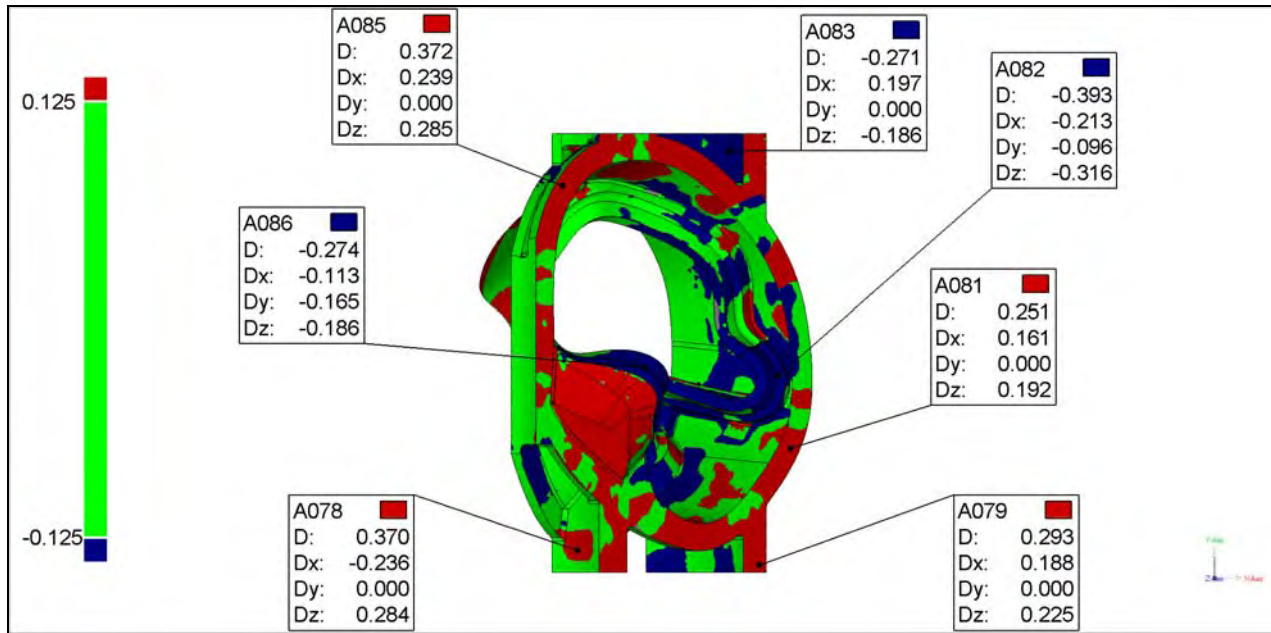

Units: in

Name	Dev	Status	Tol +	Tol -	Ref X	Ref Y	Ref Z	Dev Radius	Dev X	Dev Y	Dev Z	Test X	Test Y	Test Z
A078	0.370	FAIL	0.100	-0.100	22.125	-43.372	-26.471	0.039	-0.236	0.000	0.284	21.889	-43.372	-26.187
A079	0.293	FAIL	0.100	-0.100	62.028	-46.623	-51.069	0.039	0.188	0.000	0.225	62.216	-46.623	-50.844
A081	0.251	FAIL	0.100	-0.100	68.826	-20.908	-56.773	0.039	0.161	0.000	0.192	68.987	-20.908	-56.581
A082	-0.393	FAIL	0.100	-0.100	66.166	-4.946	-54.617	0.039	-0.213	-0.096	-0.316	65.953	-5.043	-54.932
A083	-0.271	FAIL	0.100	-0.100	55.230	44.415	-51.785	0.039	0.197	0.000	-0.186	55.427	44.415	-51.971
A085	0.372	FAIL	0.100	-0.100	18.874	36.730	-14.858	0.039	0.239	0.000	0.285	19.113	36.730	-14.573
A086	-0.274	FAIL	0.100	-0.100	36.904	-3.173	-15.496	0.039	-0.113	-0.165	-0.186	36.791	-3.338	-15.682

Annotated: Annotation View Back

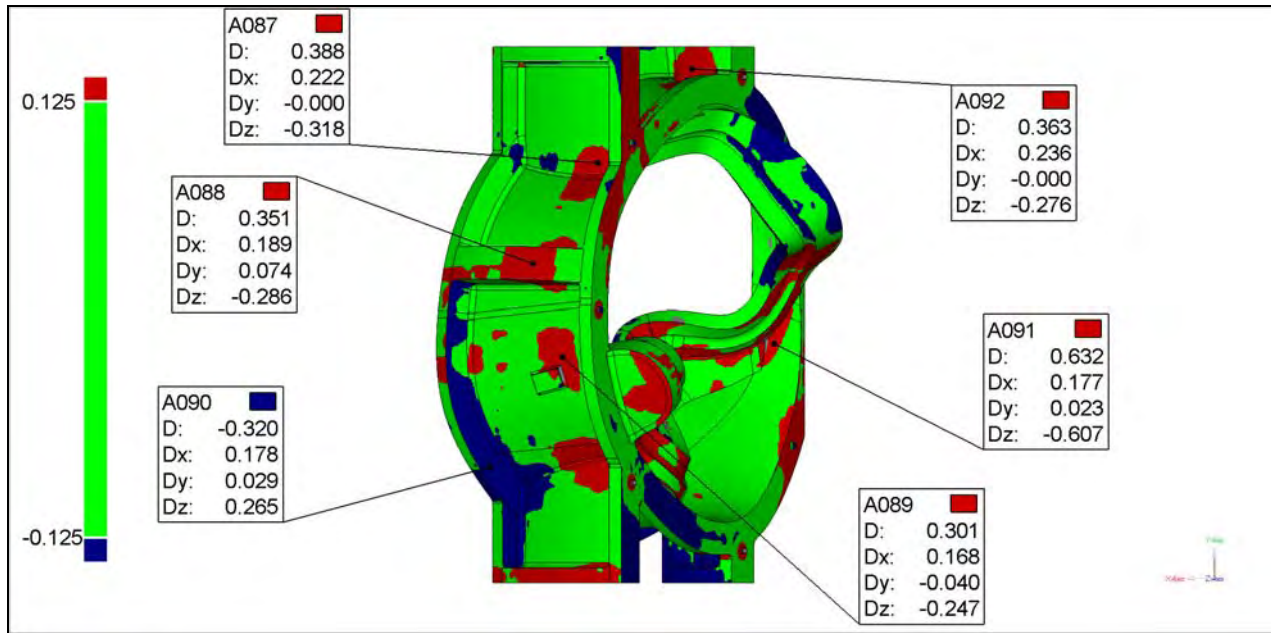

Units: in

Name	Dev	Status	Tol +	Tol -	Ref X	Ref Y	Ref Z	Dev Radius	Dev X	Dev Y	Dev Z	Test X	Test Y	Test Z
A087	0.388	FAIL	0.100	-0.100	44.656	27.300	-63.543	0.039	0.222	-0.000	-0.318	44.878	27.300	-63.861
A088	0.351	FAIL	0.100	-0.100	56.271	9.151	-73.572	0.039	0.189	0.074	-0.286	56.460	9.225	-73.859
A089	0.301	FAIL	0.100	-0.100	50.948	-7.547	-71.367	0.039	0.168	-0.040	-0.247	51.115	-7.587	-71.614
A090	-0.320	FAIL	0.100	-0.100	64.015	-27.391	-56.486	0.039	0.178	0.029	0.265	64.193	-27.363	-56.221
A091	0.632	FAIL	0.100	-0.100	12.954	-5.127	-14.409	0.039	0.177	0.023	-0.607	13.131	-5.105	-15.016
A092	0.363	FAIL	0.100	-0.100	27.716	44.240	-32.733	0.039	0.236	-0.000	-0.276	27.952	44.240	-33.009

Annotated: Annotation View Isometric

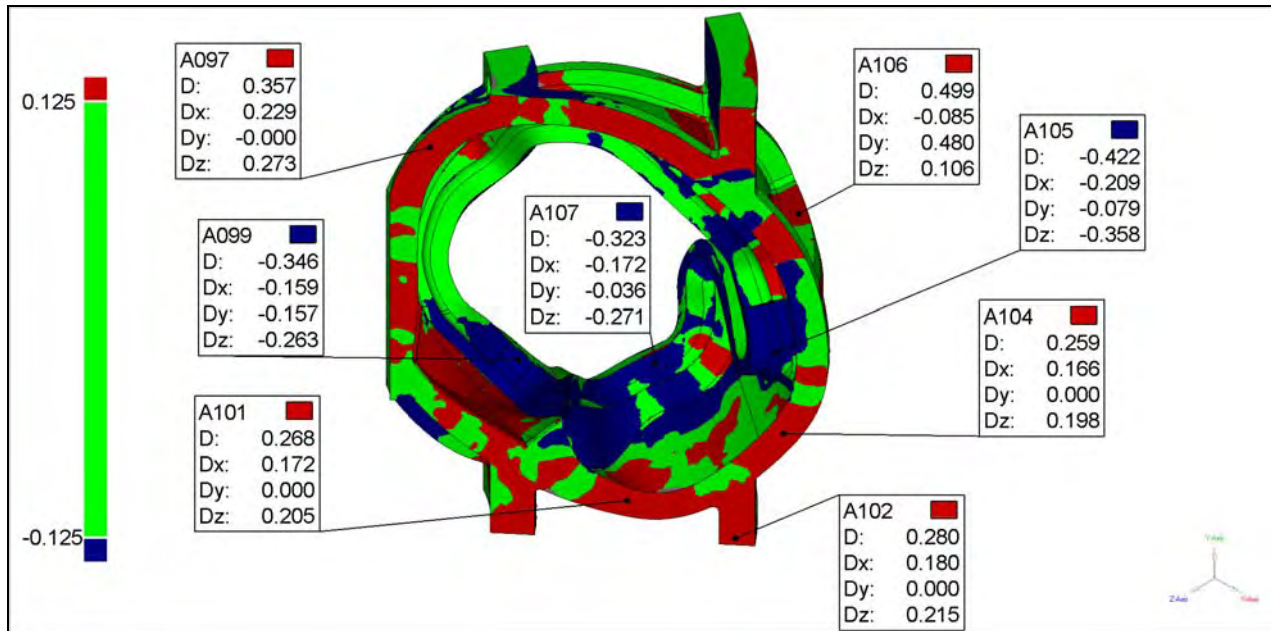

Units: in

Name	Dev	Status	Tol +	Tol -	Ref X	Ref Y	Ref Z	Dev Radius	Dev X	Dev Y	Dev Z	Test X	Test Y	Test Z
A097	0.357	FAIL	0.100	-0.100	18.638	35.973	-14.660	0.039	0.229	-0.000	0.273	18.868	35.973	-14.387
A099	-0.346	FAIL	0.100	-0.100	38.499	-2.006	-17.121	0.039	-0.159	-0.157	-0.263	38.340	-2.164	-17.385
A101	0.268	FAIL	0.100	-0.100	45.849	-39.638	-37.493	0.039	0.172	0.000	0.205	46.021	-39.638	-37.288
A102	0.280	FAIL	0.100	-0.100	60.736	-46.739	-49.985	0.039	0.180	0.000	0.215	60.917	-46.739	-49.770
A104	0.259	FAIL	0.100	-0.100	67.436	-23.082	-55.606	0.039	0.166	0.000	0.198	67.602	-23.082	-55.408
A105	-0.422	FAIL	0.100	-0.100	66.355	-5.353	-54.634	0.039	-0.209	-0.079	-0.358	66.146	-5.431	-54.992
A106	0.499	FAIL	0.100	-0.100	55.821	11.733	-70.985	0.039	-0.085	0.480	0.106	55.736	12.213	-70.879
A107	-0.323	FAIL	0.100	-0.100	35.687	-23.162	-54.842	0.039	-0.172	-0.036	-0.271	35.515	-23.198	-55.113



Carondelet Division

Pevely, MO 63070
(636) 475-2100

C-2 Doc Package
Document # 25a

9/6/2005

Annotated: All

Units: in

Name	Dev	Status	Tol +	Tol -	Ref X	Ref Y	Ref Z	Dev Radius	Dev X	Dev Y	Dev Z	Test X	Test Y	Test Z
A032	0.470	FAIL	0.100	-0.100	54.294	11.519	-71.235	0.039	-0.079	0.453	0.098	54.215	11.972	-71.137
A033	0.442	FAIL	0.100	-0.100	11.899	30.670	-36.884	0.039	-0.302	0.311	0.085	11.597	30.981	-36.798
A034	0.861	FAIL	0.100	-0.100	27.749	40.157	-38.073	0.039	-0.172	0.827	-0.165	27.577	40.984	-38.237
A036	-0.324	FAIL	0.100	-0.100	36.863	-3.808	-14.297	0.039	-0.155	-0.281	-0.040	36.708	-4.090	-14.337
A037	0.067	PASS	0.100	-0.100	57.469	48.188	-51.942	0.039	0.000	0.067	0.000	57.469	48.255	-51.942
A038	0.025	PASS	0.100	-0.100	5.558	19.704	-29.553	0.039	-0.019	0.014	0.007	5.539	19.718	-29.546
A039	0.584	FAIL	0.100	-0.100	7.399	10.856	-28.360	0.039	0.026	-0.546	-0.208	7.425	10.310	-28.567
A040	-0.279	FAIL	0.100	-0.100	12.590	14.051	-38.580	0.039	-0.212	0.180	0.020	12.377	14.230	-38.560
A041	0.319	FAIL	0.100	-0.100	56.713	6.078	-72.483	0.039	0.034	-0.315	-0.037	56.747	5.762	-72.520
A044	0.342	FAIL	0.100	-0.100	37.135	-31.757	-58.654	0.039	0.166	-0.279	-0.107	37.301	-32.037	-58.761
A045	-0.303	FAIL	0.100	-0.100	41.032	-8.625	-21.418	0.039	-0.270	0.128	-0.052	40.762	-8.497	-21.469
A047	0.271	FAIL	0.100	-0.100	30.470	-23.402	-21.884	0.039	0.039	-0.155	0.219	30.509	-23.558	-21.665
A048	-0.027	PASS	0.100	-0.100	38.270	-38.262	-43.393	0.039	0.001	0.027	0.004	38.270	-38.235	-43.390
A051	-0.356	FAIL	0.100	-0.100	44.544	44.812	-61.169	0.039	0.208	-0.001	-0.289	44.752	44.811	-61.458
A052	0.337	FAIL	0.100	-0.100	53.352	9.964	-61.169	0.039	-0.294	0.040	-0.160	53.058	10.004	-61.329
A053	0.404	FAIL	0.100	-0.100	36.665	-24.158	-61.411	0.039	-0.295	-0.064	-0.269	36.371	-24.222	-61.680
A054	-0.282	FAIL	0.100	-0.100	38.553	-45.608	-68.276	0.039	0.244	0.000	0.141	38.798	-45.608	-68.135
A055	0.732	FAIL	0.100	-0.100	32.132	-29.208	-33.635	0.039	-0.657	-0.200	0.254	31.476	-29.408	-33.381
A056	0.921	FAIL	0.100	-0.100	7.357	10.477	-18.642	0.039	-0.571	0.234	0.683	6.786	10.711	-17.959
A057	-0.273	FAIL	0.100	-0.100	18.242	37.816	-18.201	0.039	0.195	-0.026	0.189	18.437	37.790	-18.012
A058	0.005	PASS	0.100	-0.100	8.213	24.147	-30.989	0.039	-0.004	0.003	0.001	8.209	24.149	-30.988
A063	0.379	FAIL	0.100	-0.100	18.531	36.560	-14.571	0.039	0.244	0.000	0.290	18.775	36.560	-14.280
A064	-0.361	FAIL	0.100	-0.100	40.476	-9.285	-16.439	0.039	-0.309	0.106	-0.155	40.167	-9.179	-16.594
A071	0.348	FAIL	0.100	-0.100	45.441	-37.411	-37.150	0.039	0.223	0.000	0.266	45.664	-37.411	-36.884
A072	0.613	FAIL	0.100	-0.100	43.968	-27.330	-64.018	0.039	0.344	0.000	-0.508	44.312	-27.330	-64.526
A073	-0.256	FAIL	0.100	-0.100	65.593	-5.551	-53.854	0.039	-0.219	-0.032	-0.128	65.374	-5.583	-53.983
A074	0.356	FAIL	0.100	-0.100	57.859	9.211	-72.488	0.039	0.197	0.076	-0.287	58.056	9.287	-72.775
A077	0.446	FAIL	0.100	-0.100	44.242	23.247	-65.712	0.039	0.191	0.309	-0.258	44.433	23.557	-65.970
A078	0.370	FAIL	0.100	-0.100	22.125	-43.372	-26.471	0.039	-0.236	0.000	0.284	21.889	-43.372	-26.187
A079	0.293	FAIL	0.100	-0.100	62.028	-46.623	-51.069	0.039	0.188	0.000	0.225	62.216	-46.623	-50.844
A081	0.251	FAIL	0.100	-0.100	68.826	-20.908	-56.773	0.039	0.161	0.000	0.192	68.987	-20.908	-56.581
A082	-0.393	FAIL	0.100	-0.100	66.166	-4.946	-54.617	0.039	-0.213	-0.096	-0.316	65.953	-5.043	-54.932
A083	-0.271	FAIL	0.100	-0.100	55.230	44.415	-51.785	0.039	0.197	0.000	-0.186	55.427	44.415	-51.971
A085	0.372	FAIL	0.100	-0.100	18.874	36.730	-14.858	0.039	0.239	0.000	0.285	19.113	36.730	-14.573
A086	-0.274	FAIL	0.100	-0.100	36.904	-3.173	-15.496	0.039	-0.113	-0.165	-0.186	36.791	-3.338	-15.682
A087	0.388	FAIL	0.100	-0.100	44.656	27.300	-63.543	0.039	0.222	-0.000	-0.318	44.878	27.300	-63.861
A088	0.351	FAIL	0.100	-0.100	56.271	9.151	-73.572	0.039	0.189	0.074	-0.286	56.460	9.225	-73.859
A089	0.301	FAIL	0.100	-0.100	50.948	-7.547	-71.367	0.039	0.168	-0.040	-0.247	51.115	-7.587	-71.614
A090	-0.320	FAIL	0.100	-0.100	64.015	-27.391	-56.486	0.039	0.178	0.029	0.265	64.193	-27.363	-56.221
A091	0.632	FAIL	0.100	-0.100	12.954	-5.127	-14.409	0.039	0.177	0.023	-0.607	13.131	-5.105	-15.016
A092	0.363	FAIL	0.100	-0.100	27.716	44.240	-32.733	0.039	0.236	-0.000	-0.276	27.952	44.240	-33.009
A097	0.357	FAIL	0.100	-0.100	18.638	35.973	-14.660	0.039	0.229	-0.000	0.273	18.868	35.973	-14.387
A099	-0.346	FAIL	0.100	-0.100	38.499	-2.006	-17.121	0.039	-0.159	-0.157	-0.263	38.340	-2.164	-17.385
A101	0.268	FAIL	0.100	-0.100	45.849	-39.638	-37.493	0.039	0.172	0.000	0.205	46.021	-39.638	-37.288
A102	0.280	FAIL	0.100	-0.100	60.736	-46.739	-49.985	0.039	0.180	0.000	0.215	60.917	-46.739	-49.770
A104	0.259	FAIL	0.100	-0.100	67.436	-23.082	-55.606	0.039	0.166	0.000	0.198	67.602	-23.082	-55.408
A105	-0.422	FAIL	0.100	-0.100	66.355	-5.353	-54.634	0.039	-0.209	-0.079	-0.358	66.146	-5.431	-54.992
A106	0.499	FAIL	0.100	-0.100	55.821	11.733	-70.985	0.039	-0.085	0.480	0.106	55.736	12.213	-70.879
A107	-0.323	FAIL	0.100	-0.100	35.687	-23.162	-54.842	0.039	-0.172	-0.036	-0.271	35.515	-23.198	-55.113

Carondelet Division

8600 Commercial Blvd. - Pevely, MO 63070 USA
Phone: 636-479-4499 - Fax: 636-479-3399

Material Test Report

ENERGY INDUSTRIES OF OHIO

Purchase Order Number PPPL-FP-LTS-2 Heat Number 29198 Pour Date 4/28/2005
Pattern Number SE-141-073 COIL C SHIM (-3 thru -6 Parts) Cert Number S73220-2 and
SE-141-033 COIL A SHIM (-1 thru -6 Parts) Cert Number S76220-1
CAF Metal Designation CF8MNMnMod
Material Spec CF8MNMN MOD

Revised 9/24/05

Element	Min	Actual	Max
C	0.040	0.070	0.070
CR	18.000	18.100	18.500
MN	2.300	2.970	2.800
MO	2.100	2.450	2.500
N	0.240	0.255	0.280
NI	13.000	13.120	13.500
P*	0.000	0.013	0.035
S*	0.000	0.010	0.025
SI	0.000	0.700	0.700

MN & SI previously reported on CA 1308 and were accepted.

*P & S taken from test from heat parts were poured from and analyzed by wet chemistry, ASTM E1019-03 for sulfur and Gravimetric for phosphorous.

This report covers the eleven castings poured from heat 29198. Only parts listed above however will be shipped for this order. Each casting has a unique number stamped in the part adjacent to the pattern number to differentiate the part and subsequent reporting that will be traced to the casting.

Specification limits have been updated to latest specification.

Respectfully Submitted,
Charles A. Ruud
Quality Assurance Manager

Superior Quality Engineered Metal Products
www.MetalTekInt.Com

2

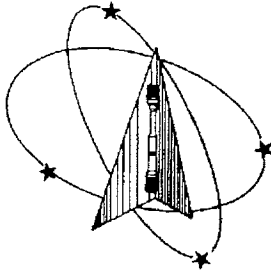

Westmoreland Mechanical Testing & Research, Inc.
 P.O. Box 388
 Westmoreland Drive
 Youngstown, Pa. 15696-0388 U.S.A.
 Telephone: 724-537-3131 Fax: 724-537-3151
 Website: www.wmtr.com
 WMTR is a technical leader in the material testing industry.

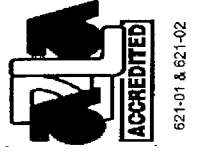

June 20, 2005

CERTIFICATION

MetalTek International
 The Carondelet Division
 8600 Commercial Blvd.
 I-55 Industrial Park
 Pevelly, MO 63070-1528

Section 1 of 1
 WMT&R Report No. 5-29403
 Req. No. 5394

Attention: Rick Suria
 Subject: All processes, performed upon the material as received, were conducted at WMT&R, Inc. in accordance with the WMT&R Quality Assurance Manual, Rev. 9, dated 4/1/2000.
 The following tests were performed on this order: TENSILE

TENSILE RESULTS: ASTM E21-03a
SOAK TIME: 5 Minutes
SPEED OF TESTING: 0.0030 in./in./min., 0.0500 in./min./in.
MATERIAL: Metaltek CF8MMnMOD

Sample	TestLog Number	Temp. °F	UTS ksi	0.2% YS ksi	Elong %	RA %	Modulus Msi	Ult. Load lbf	0.2% YLD. lbf	Orig. Dia. (in.)	Final Dia. (in.)	4D Orig. GL (in.)	4D Final GL (in.)	Orig. Area (sq. in.)	Machine Number	AIUR
29198 (1)	C03696	-320	166.1	96.0	57	62	28.6	33330	19260	0.5054	0.3103	2.00	3.14	0.20061359	M9	R
29198 (2)	C03697	-320	161.4	96.8	38	33	28.8	32390	19430	0.5055	0.4130	2.00	2.75	0.20069299	M9	R
29198 (3)	C03698	-320	165.0	92.6	62	62	27.6	33100	18581	0.5054	0.3109	2.00	3.23	0.20061359	M9	R

DISPOSITION: Report

AIUR: A=ACCEPTABLE, U=UNACCEPTABLE, R=REPORT

Matthew J. Wojcik
 Roy E. Starr
 Technical Services Manager / Tensile Supervisor
 6-20-05
 June 20, 2005

C-2 Doc Package
 Document # 27

KNOWLEDGE OR WILLFULLY FALSIFYING OR CONCEALING A MATERIAL FACT ON THIS FORM OR MAKING FALSE, FICTITIOUS OR FRAUDULENT STATEMENTS OR REPRESENTATIONS HEREIN COULD CONSTITUTE A FELONY PUNISHABLE UNDER FEDERAL STATUTES. THIS CERTIFICATE OR REPORT SHALL NOT BE REPRODUCED EXCEPT IN FULL, WITHOUT THE WRITTEN APPROVAL OF WMT&R, INC.

Testing Specialists for Aerospace, Automotive, and Material Testing Fields
 Locations in Youngstown, PA U.S.A. ~ Tel. (724) 537-3131 and
 Banbury U.K. ~ Tel. +44 (0) 1295 261211



3

C-2 Doc Package
Document # 28

2810 Clark Avenue • St. Louis, MO 63103-2574 • (314) 531-8080 • FAX (314) 531-8085

METALTEK INTERNATIONAL
8600 Commercial Blvd.
Pevely, MO 63070

June 13, 2005
Lab No. 05P-1739
P.O. No. 12516
Page 1 of 3

Attention: Chuck Ruud

REPORT OF CHARPY IMPACT TEST

MATERIAL (SAMPLE ID): HT # 29198
SPECIFICATION: ASTM A 370-03a
SPECIMEN TYPE: "A" Vee Notch
SPECIMEN SIZE: 10 mm x 10 mm
TEMPERATURE OF TEST: 293° K / 68° F
REQUIREMENTS: 50 ft. / lb

BASE METAL	FOOT LBS.	LATERAL EXPANSION	% SHEAR
1-7	132	0.085	100
1-8	176	0.084	100
1-9	152	0.082	100
Average	153	0.084	100
BASE METAL	FOOT LBS.	LATERAL EXPANSION	% SHEAR
2-7	160	0.112	100
2-8	144	0.107	100
2-9	140	0.069	100
Average	148	0.096	100
BASE METAL	FOOT LBS.	LATERAL EXPANSION	% SHEAR
3-7	176	0.110	100
3-8	124	0.087	100
3-9	144	0.107	100
Average	148	0.101	100

Identification of tested specimen provided by client.

*Karl Schmitz, Director
Materials Testing*



Certificate No. 0397-01
Certificate No. 0397-02

AN OFFICIAL COPY OF TEST REPORT WILL BE PROVIDED BY THIS LABORATORY ON REQUEST. DO NOT REPRODUCE
NOT OFFICIAL WITHOUT THE RAISED SEAL OF ST. LOUIS TESTING LABORATORIES, INC.
SEE REVERSE FOR CONDITIONS.





C-2 Doc Package
Document # 28

2810 Clark Avenue • St. Louis, MO 63103-2574 • (314) 531-8080 • FAX (314) 531-8085

METALTEK INTERNATIONAL
8600 Commercial Blvd.
Pevely, MO 63070

June 13, 2005
Lab No. 05p-1739
P.O. No. 12516
Page 2 of 3

Attention: Chuck Ruud

REPORT OF CHARPY IMPACT TEST

MATERIAL (SAMPLE ID): HT # 29198
SPECIFICATION: ASTM A 370-03a
SPECIMEN TYPE: "A" Vee Notch
SPECIMEN SIZE: 10 mm x 10 mm
TEMPERATURE OF TEST: 77° K / -321° F
REQUIREMENTS: 35 ft / lb

BASE METAL	FOOT LBS.	LATERAL EXPANSION	% SHEAR
4-7	84	0.055	50
4-8	83	0.035	50
4-9	76	0.058	50
Average	81	0.049	50
BASE METAL	FOOT LBS.	LATERAL EXPANSION	% SHEAR
5-7	82	0.059	50
5-8	82	0.040	50
5-9	98	0.075	80
Average	87	0.058	60
BASE METAL	FOOT LBS.	LATERAL EXPANSION	% SHEAR
6-7	82	0.050	50
6-8	93	0.052	50
6-9	94	0.051	50
Average	90	0.051	50

Identification of tested specimen provided by client.

Karl Schmitz, Director
Materials Testing



AN OFFICIAL COPY OF TEST REPORT WILL BE PROVIDED BY THIS LABORATORY ON REQUEST. DO NOT REPRODUCE. NOT OFFICIAL WITHOUT THE RAISED SEAL OF ST. LOUIS TESTING LABORATORIES, INC. SEE REVERSE FOR CONDITIONS.



Certificate No. 0397-01
Certificate No. 0397-02



C-2 Doc Package
Document # 28

2810 Clark Avenue • St. Louis, MO 63103-2574 • (314) 531-8080 • FAX (314) 531-8085

METALTEK INTERNATIONAL
8600 Commercial Blvd.
Pevely, MO 63070

June 13, 2005
Lab No. 05P-1739
P.O. No. 12516
Page 3 of 3

Attention: **CHUCK RUUD**

REPORT OF MECHANICAL TESTS

SAMPLE ID: 3 EA., 29198

Sample ID	Original Area Sq. inches	Reduced Area Sq. inches	Reduction in Area %	Modules of Elasticity	Yield Strength PSI	Tensile Strength PSI	Elongation (2.0" Gage Length)	
							in.	%
29298-1	0.1817	0.0855	52.9	21.2 Msi	40600	91900	1.00	50.0
29198-2	0.1825	0.0962	47.3	20.9 Msi	42700	88500	1.00	50.0
29198-3	0.1840	0.1170	36.4	21.1 Msi	39500	88300	0.97	48.5

Round, reduced section room temperature tensiles

Yield taken at .2% offset

Tested in accordance with ASTM A 370-03a

Identification of tested specimens provided by the client.

KS/tiv

Karl Schmitz, Director
Materials Testing



Certificate No. 0397-01
Certificate No. 0397-02

AN OFFICIAL COPY OF TEST REPORT WILL BE PROVIDED BY THIS LABORATORY ON REQUEST. DO NOT REPRODUCE.
NOT OFFICIAL WITHOUT THE RAISED SEAL OF ST. LOUIS TESTING LABORATORIES, INC.
SEE REVERSE FOR CONDITIONS





C-2 Doc Package
Document # 29

Carondelet Division

8600 Commercial Blvd. - Pevely, MO 63070 USA
Phone: 636-479-4499 - Fax: 636-479-3399

Final Inspection Report

Customer Name: ENERGY
INDUSTRIES OF
OHIO

Pattern: SE-141-073 COIL C SHIM

Order Number: PPPL-FP-LTS-2

ASTM Metal CF8MNMN MOD

Date 6/22/2005

Type Description	Cert Number	Procedure	Acceptance Criteria	Actual
Liquid Penetrant	S73220-2	CQP - 300 Rev 9	ASTM A903 Level II	Acceptable
Mag Perm	S73220-2	SOP Mag Perm 100 Rev 1	<1.02	Acceptable
Radiographic	S73220-2	Technique # 12726	MSS SP 54	Acceptable
Visual	S73220-2	CQP - 500 REV 4	ASTM A802 LEVEL 2	Acceptable

Respectfully Submitted,
Charles A. Ruud
Quality Assurance Manager



C-2 Doc Package
Document # 30

Carondelet Division

8600 Commercial Blvd. - Pevely, MO 63070 USA
Phone: 636-479-4499 - Fax: 636-479-3399

Certificate of Conformance

ENERGY INDUSTRIES OF OHIO

Order Number PPPL-FP-LTS-2

Pattern SE-141-073 COIL C 2 SHIM S/ N 6

ASTM CF8MNMN MOD

Date 10/26/2005

Cert Number

S73220-2

Shim was not weld repaired. RT 2 on reader sheet refers to a number the x-ray department uses to track parts. It does not refer to a weld repair.

A handwritten signature in black ink, appearing to read "CARUUD", is positioned above the typed name.

Respectfully Submitted,
Charles A. Ruud
Quality Assurance Manager

Superior Quality Engineered Metal Products

www.MetalTekInt.Com

Corrective Action 1308
Carondelet Division - CA / PA / RGA Database
Corrective Action Type NCR
Date 6/13/2005
CA Originator C. Ruud
Pattern Number: C and A Coil Shims 11 Pieces

Description of Defect / Non-Conformance

Chemistry for 11 shim castings is out of specification.

Root Cause

Chemistry specification was not changed in system and not communicated to Lab personnel.

Corrective Action

Specification was corrected in system and Lab personnel trained. Mag permeability was checked on the parts and are less than 1.02u.

Verification of Corrective Action

Chemistries were checked on subsequent parts and are within specification.

Preventive Action

Create Inspection and Test Plan summarizing all requirements.

Estimated Completion Date

6/15/05

Actual Completion Date

Complete.



Signed: C. Ruud

CC: Roger Broman, Barry Craig, Joe Edwards, E.J. Kubick

MetalTek INTERNATIONAL

C-2 Doc Package
Document # 32

RADIOGRAPHIC INTERPRETATION REPORT

CUSTOMER <i>Energy Industries of Ohio</i>		PURCHASE ORDER NUMBER <i>PPPL FP-LTS-2</i>				DATE <i>6-23-05</i>		CONTROL NO. <i>40851</i>		PAGE <i>1 of 1</i>											
PART NO. <i>SE-141-073 coil C shim</i>		SPECIFICATION <i>E 186</i>		CLASS <i>III</i>		TOTAL PIECES <i>1</i>		PIECES ACCEPTED <i>1</i>													
RADIOGRAPHED BY: <i>Malych</i>				INTERPRETED BY: <i>Malych</i>				ASNT LEVEL <i>II</i>													
FILM TYPE <i>50</i>		MATERIAL <i>CF8 Mn Ni Mo</i>		ISOTOPE <i>IRIDIUM 192 COBALT 60 V</i>				CODE <i>ASTM E94 ASME V MIL-STD-453</i>													
<i>-6 part</i>		VIEW		ACCEPT		REJECT		SHRINK		INCLUSION		POROSITY		LINEAR		SURFACE		LOF / LOOP		COMMENTS 	
<i>MS73220-2</i>		<i>RT-2</i>		<i>A 50</i>																	
		<i>B</i>																			
		<i>C</i>																			
		<i>D</i>																			
		<i>E</i>																			

RADIOGRAPHIC STANDARD SHOOTING SKETCH

Customer <u>Energy Industries of Ohio</u>	Pattern Number <u>SE-141-073</u>
Material <u>CF8MNMN-MOD</u>	Traceability Number <u>M573220</u>
Film Manufacturer <u>FUJI</u>	Source Number <u>CO60 247 CI</u>
IQI LEVEL <u>2-2T</u> From CQP 401 <input checked="" type="checkbox"/> Other (Specify, E.G. 2-4T, 2-1T) <u>N/A</u>	

Exposures (views)	A	B	C	D	E										
Thickness (IN.)	<u>3 3/8"</u>	→													
S/F Distance (IN.)	<u>24"</u>	→													
Penetrameter	<u>50</u>	→													
Time (MIN.)	<u>Calculate</u>	→													
Focal Spot (IN.)	<u>#1</u>	→													
Film Size (IN.)	<u>14X17</u>	→													
Screen Size (Pb) Front/Back	<u>,01</u>	→													
S.W.E./D.W.E.	<u>SWE</u>	→													
S.W.V./D.W.V.	<u>SWV</u>	→													
Film Type	<u>80</u>	→													
Acceptance Standard	<u>E186</u>	→													
Severity Level	<u>III</u>	→													

Shooting Sketch (Use Additional Pages as Needed)

use Spec. MSS-SP-54

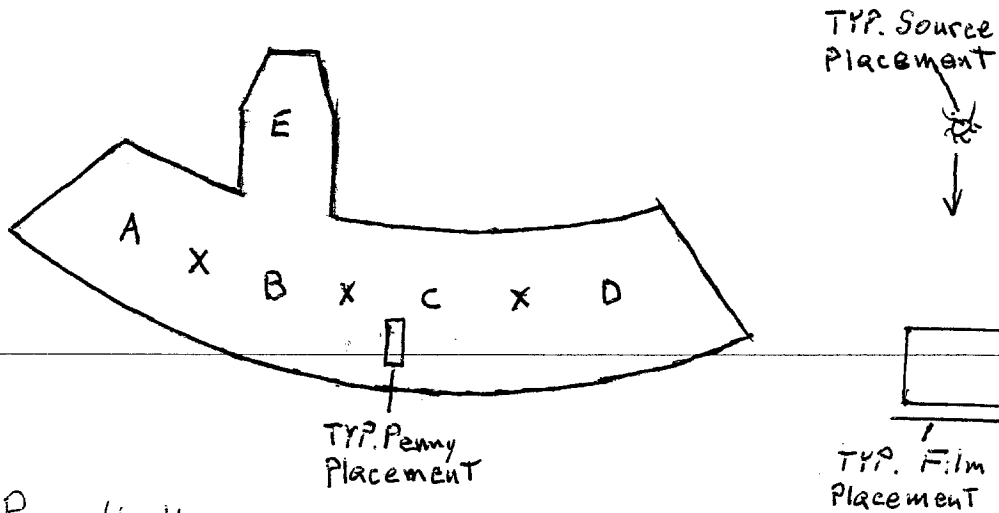

Technique Prepared By: Ron Kelley
Technique Approved By: [Signature]

Level: II
Level: III

Date: 3-10-05
Date: 3-10-05

C Shim

C-2 Doc Package
Document # 33

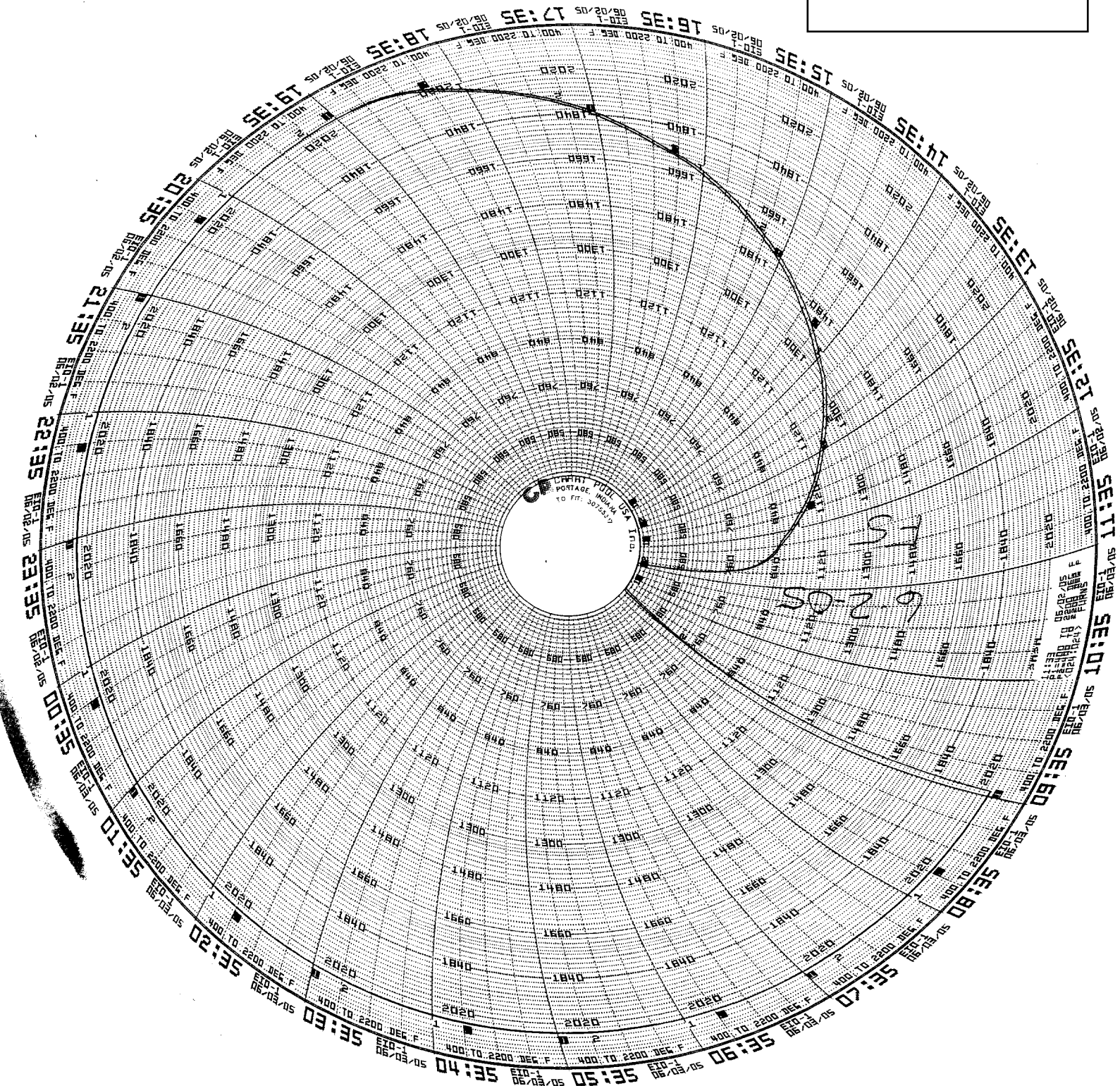

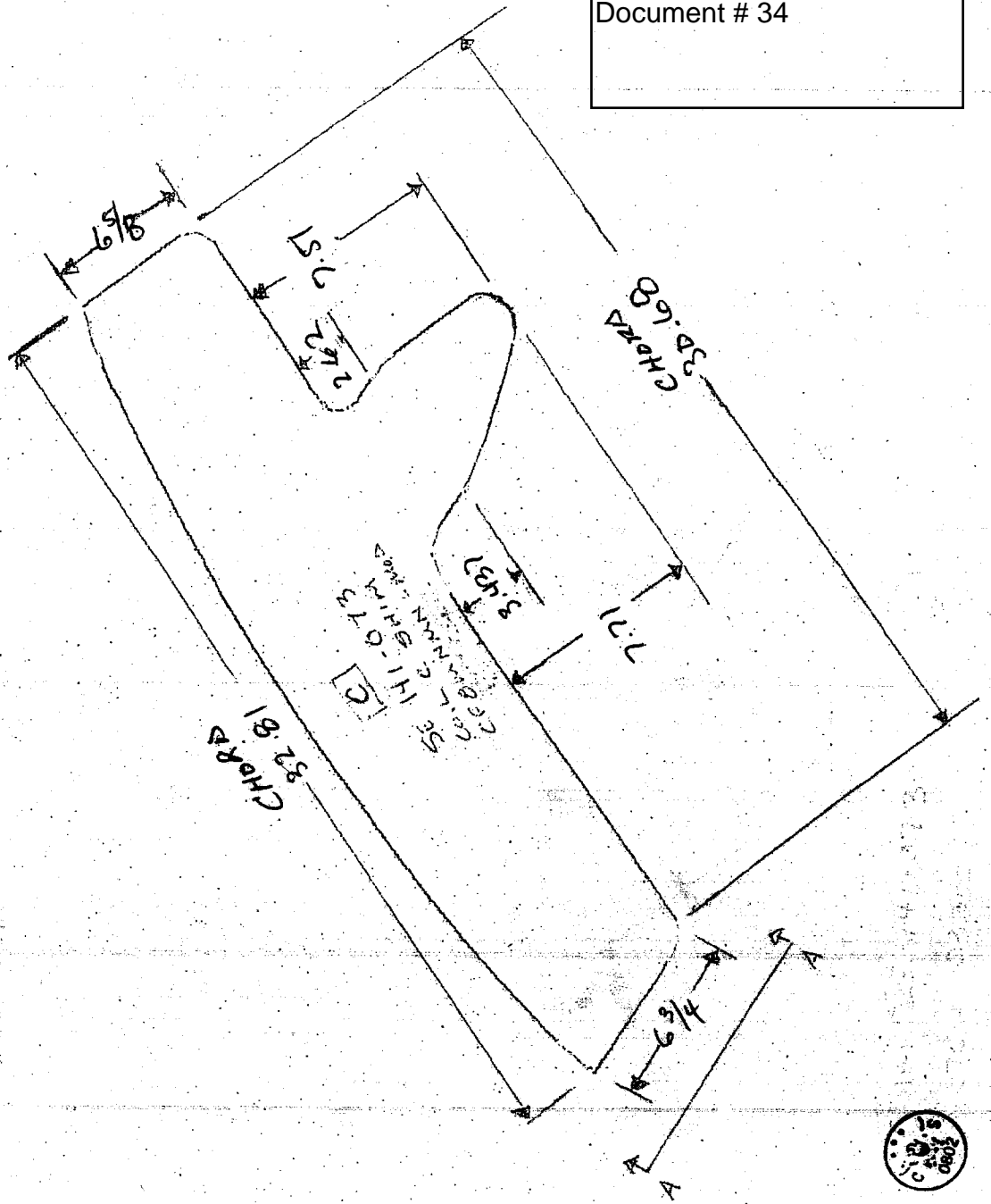

SECT A-A



SHIM SE 141-073-6
SKETCH 6/23/05

[Handwritten signature]

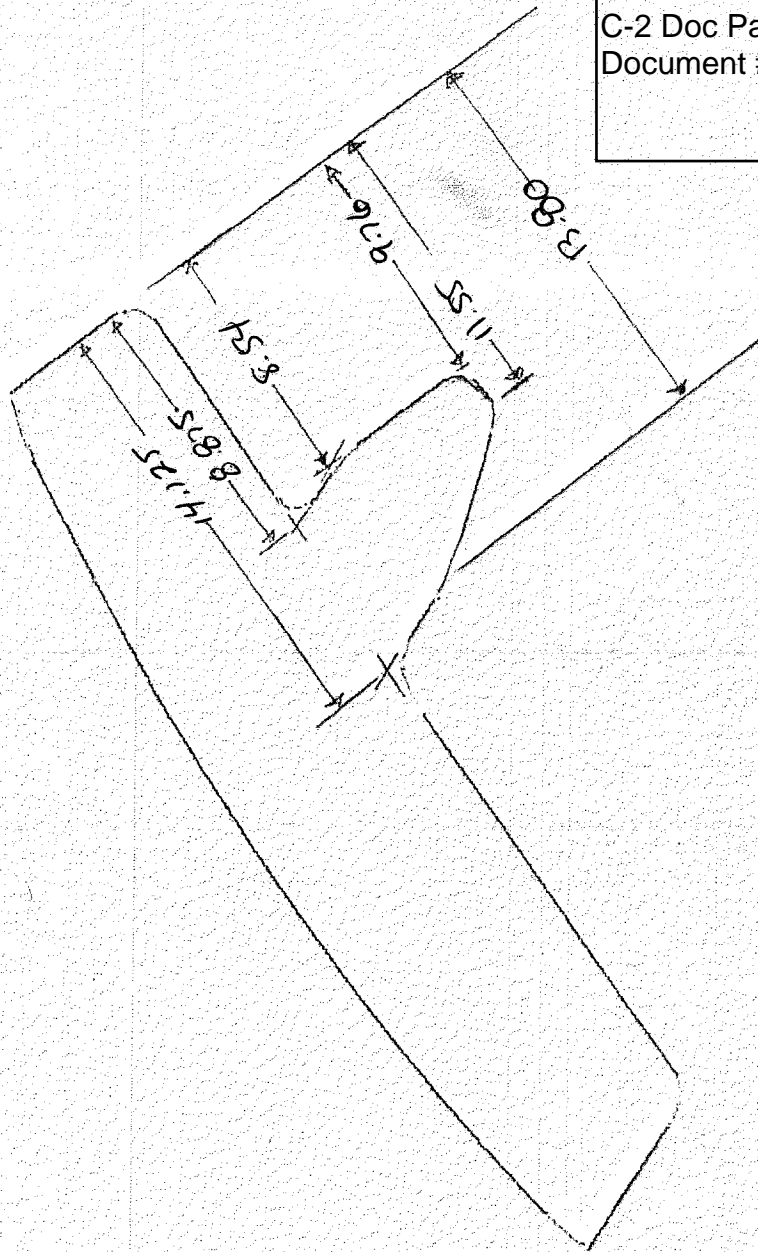

PAGE 2 OF 2
SHIM DE 141-073-6
SKETCH 6/23/05

OPER. #	STATION	DESCRIPTION OF PROCESS	Name	Date
10	QUALITY RELEASE	Keep all parts together. Sign and date each step when all 5 parts have been completed. REVIEW AND APPROVE MTS. RECEIVED APPROVAL FROM EIO ON <u>Date</u> FROM <u>12/15/04</u> SIGNED QUALITY MANAGER	<i>Chc</i>	<i>4/21/05</i>
20	PATTERN NPAT SOP 01000REV2	APPLY APPROPRIATE PART NUMBER, SERIAL NUMBER, FOUNDRY MARK, TO THE PATTERN.	<i>TB</i>	<i>4/22/05</i>
30	MOLD MOLD SOP 0400 REV 8 CALIBRATION PER MOLD SOP 0900 REV 5 PREPARATION PER MOLD SOP 1100R2/1200R2/13 00R1 SAND TESTING PER MOLD SOP 1400R2/1500R3/16 00R2	MOLD PER WORK INSTRUCTIONS IN MAPICS ROUTING AND SOPS REFERENCED. ENGINEER OF RECORD - ROGER BROMAN, CONSULT ON MOLD-RELATED CONCERNS. MOLD MATERIALS REQUIRED PER MAPICS BOM. NOTIFY ENGINEER OF ANY SUBSTITUTIONS.	<i>CR</i>	<i>4/22/05</i>
40	POUR MELT SOP 0100R5 MELT SOP 0700R2 MELT SOP 0600R2	METAL MUST BE AOD REFINED OR AOD INGOT. VIRGIN METAL ADDITIONS ALLOWED. RECORD POURING TEMPERATURE: <u>2825</u> CASTING Poured AT: <u>12-15-04</u> DATE: <u>4/28</u> HEAT #'s: <u>29198</u> ELAPSED POUR TIME: <u>44</u> KEEL BLOCKS Poured: <u>42</u> Sample from ladle to be analyzed for final chemical analysis and reported on material certifications. Sample Taken by: <u>SR</u> Analyzed: <u>G Hunt</u> Date: <u>4/28</u> Note: Make 15 additional test bars for mechanical testing.	<i>JG</i>	<i>4/28/05</i>
50	MELT SOP 0800R2	SHAKEOUT	<i>CA</i>	<i>4/29</i>
60	ARC RISE SOP 0100R1	REMOVE RISERS AS DIRECTED BY SUPERVISOR.	<i>BMW</i>	<i>4/10/05</i>
70	HEAT TREAT HEAT SOP 0103R5	SOLUTION ANNEAL. With C-1 Coil.	<i>DLS</i>	<i>6/2/05</i>

80	PHYSICAL TESTING	OBTAIN TEST SPECIMENS AND SUBMIT FOR PHYSICAL TESTING. REPORT RESULTS AS PART OF STEP 480.	WT	4/29/05
90	GRIND GSWA SOP 0100R3 GCHI SOP 0100R2	SWING GRIND TO REMOVE RISER REMAINS AND FLASH IF REQUIRED. CHIP AND HAND GRIND SURFACE OF PART AS REQUIRED.	CEG	7/8 6/16/05
100	SANDBLAST BLAS SOP 0100R6	SANDBLAST (REMOVE ALL BLAST MATERIAL FROM CASTING) SANDBLASTING WILL BE DONE USING RECYCLED SHARP ANGULAR AGGREGATE.	MW	6/16/05
110	VISUAL INSPECTION CQP-500 REV 4	VISUALLY INSPECT 100% OF COMPONENT ACCORDING TO ASTM A802 LEVEL 3 ALL CONDITIONS. IF OK CHECK HERE <input checked="" type="checkbox"/> COMPONENT ACCORDING TO ASTM A802 LEVEL 3 ALL CONDITIONS. IF REJECTED CHECK HERE _____ MARK AND REPAIR AT STEP 130.	VT- LEVEL II	3543 6-16-05
NOTICE	WITNESS NOTIFICATION	PROVIDE NOTICE TO EIO AND DCMA AT LEAST FIVE DAYS IN ADVANCE OF LP STEP. EIO NOTIFIED ON <u>6/10/05</u> DCMA NOTIFIED ON <u>6/10/05</u>	Q ENG OR QA MGR	CAR 6-16-05
120	100% L.P. CQP 0300 REV 10	L.P. 100% OF COMPONENT. ACCEPTANCE PER ASTM A903. ACCEPTANCE CRITERIA- LEVEL 2. IF OK CHECK HERE <input checked="" type="checkbox"/> IF REJECTED CHECK HERE _____ MARK AND REPAIR AT STEP 120.	LP- LEVEL II	S.S.R. 6-16-05
130	WELD SOP 0100 REV 7	EXCAVATE ANY DEFECTS FOUND DURING 100% VISUAL AND LP INSPECTION.	CAF	4/20
140	L.P. EXCAVATION CQP-300 REV 10	L.P. ALL EXCAVATIONS PRIOR TO WELDING TO ENSURE REMOVAL OF DEFECT. ACCEPTANCE PER A903. ACCEPTANCE CRITERIA- LEVEL 2 <i>All defects ground out</i>	LP- LEVEL II	D.F. 4/23/05
150	SANDBLAST BLAS SOP 0100R6	SANDBLAST (REMOVE ALL BLAST MATERIAL FROM CASTING) SANDBLASTING WILL BE DONE USING RECYCLED SHARP ANGULAR AGGREGATE.	MW	6/23/05
160	WELD MAP	MAP ALL WELDS WITH DIGITAL PHOTO/MAPS. SERIALIZE DEFECTS ON CASTING. USE SCALE IN PHOTOS AND DOCUMENT SIZE. THIS IS TO BE PERFORMED BY SUPERVISOR, INSPECTION LEAD MAN OR THEIR DESIGNEE. FILE WITH QA. USE YELLOW MARKER. MUST SEND REPORT ON ALL WELDS OVER 10% OF NOMINAL WALL THICKNESS TO CUSTOMER. DEFECTS > 10% YES _____, REPORT SENT BY _____ DATE _____ DEFECTS < 10% _____ SIGN BY QA ENG.	Dot Reground	
NOTICE	WITNESS NOTIFICATION	PROVIDE NOTICE TO EIO AND DCMA AT LEAST FIVE DAYS IN ADVANCE OF XRAY AND LAYOUT STEPS. EIO NOTIFIED ON <u>6/10/05</u> DCMA NOTIFIED ON <u>6/20/05</u>	Q ENG OR QA MGR	CAF

FIVE PARTS KEEP TOGETHER -6

Energy Industries of Ohio
 Manufacturing and Test Sequence (MTS) Coill C Shim
 CO# 40851, Pattern SE 141-073 MS73220-2 Dated December 14, 2004 Revision: Original

Page 3 of 6 Dated Issued: 4-27-05

170	CAF X-RAY CQP 401 REV 5	X-RAY PER TECHNIQUE: To be determined. USE CALIBRATED DENSITOMETER FOR DENSITY VERIFICATION. ATTACH TECHNIQUE, READER SHEET FOR ALL RADIOGRAPHS. MUST INDICATE RADIOGRAPHER AND ASNT CERTIFICATION LEVEL ON READER SHEET.	RT - LEVEL II	6/23/05
180	X-RAY CQP 401 REV 5	X-RAY INTERPRETATION. ACCEPTANCE MSS SP 54. ATTACH TECHNIQUE, READER SHEET FOR ALL RADIOGRAPHS. MUST INDICATE RADIOGRAPHER AND ASNT CERTIFICATION LEVEL ON READER SHEET. IF OK CHECK HERE <input checked="" type="checkbox"/> AND SEND TO STEP 310. REJECTED CHECK HERE <input type="checkbox"/> MARK UP DEFECTS AND SEND THE CASTING TO STEP 200.	RT - LEVEL II	6/23/05
190	LAYOUT	INSPECT CASTING TO VERIFY DIMENSIONS. THIS MAY BE PERFORMED BEFORE OR AFTER STEP 180. DIMENSIONED <u>35</u> DATE <u>6/23/05</u> RELEASED _____ (ENGINEER ONLY)	RB	6/23/05
200	WELD SOP 0100 REV 7	EXCAVATE ANY DEFECTS FOUND DURING RADIOGRAPHY.		
210	L.P. EXCAVATION CQP-300 REV 10	L.P. ALL EXCAVATIONS PRIOR TO WELDING TO ENSURE REMOVAL OF DEFECT. ACCEPTANCE PER A903. ACCEPTANCE CRITERIA- LEVEL 2.	LP - LEVEL II	
220	WELD MAP	MAP ALL WELDS WITH DIGITAL PHOTO/MAPS. SERIALIZE DEFECTS ON CASTING. USE SCALE IN PHOTOS AND DOCUMENT SIZE. THIS IS TO BE PERFORMED BY SUPERVISOR, INSPECTION LEAD MAN OR THEIR DESIGNEE, FILE WITH QA. MUST SEND REPORT ON ALL WELDS OVER 10% OF NOMINAL WALL THICKNESS TO CUSTOMER. DEFECTS > 10% YES _____, REPORT SENT BY _____ DATE _____ DEFECTS < 10% _____ SIGN BY QA ENG. _____		
NOTICE	WITNESS NOTIFICATION	PROVIDE NOTICE TO EIO AND DCMA AT LEAST FIVE DAYS IN ADVANCE OF WELD STEP. EIO NOTIFIED ON _____ DCMA NOTIFIED ON _____	Q ENG OR QA MGR	
230	QA APPROVAL HOLD POINT	QA TO APPROVE ELECTRODE PRIOR TO USE. PROCEDURE USED: _____ MATERIAL USED: _____ QUALITY ENG. Name: _____ Date: _____		
240	WELD SOP 0100 REV 7	WELD REPAIR DEFECTS AS MARKED. FOR WELDS < 2" - WPS 10-SMAW-CF88MNMN MOD REV 1 FOR WELDS < 8" - WPS 15-GMAW-CF88MNMN MOD REV 2		
250	GRIND GCHI SOP 0100R2	HAND GRIND WELDS.		

C-2 Doc Package
 Document # 35



WA



FIVE PARTS KEEP TOGETHER

Manufacturing and Test Sequence (MTS) Coill C Shim

Energy Industries of Ohio
 Dated Issued: 4-27-05

CO# 40851, Pattern SE 141-073 - *2* MS73220-2 Dated December 14, 2004 Revision: Original Page 4 of 6

260	L.P. WELD COP 0300 REV 10	L.P. WELD REPAIRS ACCEPTANCE PER ASTM A903. ACCEPTANCE CRITERIA-LEVEL 2. IF OK CHECK HERE _____ WASH AND SEND TO STEP 300. IF REJECTED CHECK HERE _____ AND RETURN TO STEP 220.	LP - LEVEL II	
	REPEAT	REPEAT STEPS 220 TO 260 AS REQUIRED TILL CLEAR THROUGH VISUAL INSPECTION & PENETRANT INSPECTION. DOCUMENT REWORK ON A SUPPLEMENTAL MTS	QA ENG.	
270	TEST MAG PERM SOP MAG PERM 100, REV 1	TEST MAG PERMEABILITY REPAIR AREAS. RECORD ON WELD MAP LIST. TEST AT LEAST 5 POINTS PER WELD. ACCEPTANCE 1.02. IF OK CHECK HERE <input checked="" type="checkbox"/> AND GO TO STEP 290. IF REJECTED CHECK HERE _____.	<i>OK</i>	<i>6/23/05</i>
280	GRIND GCHI SOP 0100R2	GRIND AREAS OF NON COMPLIANCE AND RETURN TO STEP 270. REPEAT UNTILL COMPLIANCE IS ACHIEVED.		<i>OK</i>
290	CAP X-RAY DEFECTS REPAIRED BY WELDING COP 401 REV 5	X-RAY PER TECHNIQUE: To be determined. USE CALIBRATED DENSITOMETER FOR DENSITY VERIFICATION. ATTACH TECHNIQUE, READER SHEET FOR ALL RADIOGRAPHS. MUST INDICATE RADIOGRAPHER AND ASNT CERTIFICATION LEVEL ON READER SHEET.	RT - LEVEL II	
300	X-RAY COP 401 REV 5	X-RAY INTERPRETATION. ACCEPTANCE MSS SP 54. ATTACH TECHNIQUE, READER SHEET FOR ALL RADIOGRAPHS. MUST INDICATE RADIOGRAPHER AND ASNT CERTIFICATION LEVEL ON READER SHEET. IF OK CHECK HERE _____ AND SEND TO STEP 310. IF REJECTED CHECK HERE _____ MARK UP DEFECTS AND SEND THE CASTING TO STEP 200.	RT - LEVEL II	
	REPEAT	REPEAT STEPS 200 TO 300 AS REQUIRED TILL WELDS CLEAR X-RAY. DOCUMENT REWORK ON A SUPPLEMENTAL MTS	QA ENG.	
310	SAND BLAST BLAS SOP 0100R6	SANDBLAST (REMOVE ALL BLAST MATERIAL FROM CASTING) SANDBLASTING WILL BE DONE USING RECYCLED SHARP ANGULAR AGGREGATE.		<i>OK</i>
	NOTICE	PROVIDE NOTICE TO EIO AND DCMA AT LEAST FIVE DAYS IN ADVANCE OF VISUAL AND LP STEPS. EIO NOTIFIED ON <i>6/20/05</i> DCMA NOTIFIED ON <i>6/20/05</i>	Q ENG OR QA MGR	<i>OK</i>
320	FINAL VISUAL INSPECTION COP-500 REV 4	VISUALLY INSPECT 100% OF COMPONENT ACCORDING TO ASTM A802 LEVEL II CONDITIONS. IF OK CHECK HERE <input checked="" type="checkbox"/> IF REJECTED CHECK HERE _____ MARK AND REPAIR AT STEP 340.	VT - LEVEL II	<i>OK</i>

C-2 Doc Package Document # 35126



OK 6-24-05

OK

330	FINAL L.P. COP 0300 REV 10	FINAL L.P. 100% OF COMPONENT. ACCEPTANCE PER ASTM A903. ACCEPTANCE CRITERIA- LEVEL 1 FOR HIGH STRESSED AREAS, LEVEL 2 FOR ALL OTHER AREAS. SEE LP DRAWING. IF OK CHECK HERE _____ WASH AND SEND TO STEP 410. IF REJECTED CHECK HERE _____	LP - LEVEL II	
340	WELD SOP 0100 REV 7	EXCAVATE ANY DEFECTS FOUND DURING FINAL PENETRANT INSPECTION.	N/A	LP OK
350	L.P. EXCAVATION COP-300 REV 10	L.P. ALL EXCAVATIONS PRIOR TO WELDING TO ENSURE REMOVAL OF DEFECT. ACCEPTANCE PER A903.	LP - LEVEL II	
370	WELD MAP	MAP ALL WELDS WITH DIGITAL PHOTO/MAPS. SERIALIZE DEFECTS ON CASTING. USE SCALE IN PHOTOS AND DOCUMENT SIZE. THIS IS TO BE PERFORMED BY SUPERVISOR, INSPECTION LEAD MAN OR THEIR DESIGNEE. FILE WITH QA. MUST SEND REPORT ON ALL WELDS OVER 10% OF NOMINAL WALL THICKNESS TO CUSTOMER. NOMINAL WALL THICKNESS TO CUSTOMER. DEFECTS >10% YES _____, REPORT SENT BY _____ DATE _____ DEFECTS < 10% _____ SIGN BY QA ENG.		
380	WELD SOP 0100 REV 7	WELD REPAIR DEFECTS AS MARKED. FOR WELDS <2" - WPS 10-SMAW-CF8MNMN MOD REV 1 FOR WELDS <8" - WPS 15-GMAW-CF8MNMN MOD REV 2		
390	GRIND GCH SOP 0100 REV 2	HAND GRIND WELDS.		
400	L.P. WELDS COP 0300 REV 10	L.P. WELD REPAIRS ACCEPTANCE PER ASTM A903. IF OK CHECK HERE _____ WASH AND SEND TO STEP 460. IF REJECTED CHECK HERE _____ AND RETURN TO STEP 390.	LP - LEVEL II	
	REPEAT	REPEAT STEPS 390 TO 410 AS REQUIRED TILL WELDS CLEAR FINAL LIQUID PENETRANT INSPECTION. DOCUMENT REWORK ON A SUPPLEMENTAL MTS	QA ENG. ↙	
410	TEST MAG PERM SOP MAG PERM 100, REV 1	TEST MAG PERMEABILITY REPAIR AREAS. RECORD ON WELD MAP LIST. TEST AT LEAST 5 POINTS PER WELD. ACCEPTANCE 1.02. IF OK CHECK HERE _____ AND GO TO STEP 430.	N/A SEE STEP 270	

420	GRIND GCHI SOP 0100R2	GRIND AREAS OF NON COMPLIANCE AND RETURN TO STEP 420. REPEAT UNTILL COMPLIANCE IS ACHIEVED.	N/A	
NOTICE	WITNESS NOTIFICATION	PROVIDE NOTICE TO EIO AND DCMA AT LEAST FIVE DAYS IN ADVANCE OF MAG PERM STEP. EIO NOTIFIED ON _____ DCMA NOTIFIED ON _____	Q ENG OR QA MGR	
430	FINAL MAG PERM INSPECTION SOP MAG PERM 100, REV 1	PERFORM MAG PERM TESTING WITH SEVRIN GAUGE. ACCEPTANCE 1.02. CHECK THE ENTIRE SURFACE ON A 6"BY6" GRID. REPORT RESULTS. USE A 6" SQUARE BLOCK TO INDICATE TEST LOCATIONS AND RECORD RESULTS. COMPLIANT AREAS WILL NOT BE MARKED. MARK NONCOMPLIANT AREAS WITH AN "X" FOR REPAIR. OK CHECK HERE _____ AND GO TO STEP 470. IF REJECTED CHECK HERE _____	SEE STEP 270	
440	GRIND GCHI SOP 0100 REV 2	HAND GRIND WITH SUITABLE CONE OR OTHER SIMILAR GRINDER AS REQUIRED TO ENSURE REMOVAL OF MATERIAL TO ACHIEVE MAG PERM REQUIREMENT. CIRCLE AREA REMEDIATE FOR RETEST.	N/A	
450	RETEST MAG PERM SOP MAG PERM 100, REV 1	RETEST MAG PERMEABILITY AT FAILED TEST POINTS. MARK NONCOMPLIANT AREAS WITH AN "X" FOR REPAIR. ACCEPTANCE 1.02. IF OK CHECK HERE _____ IF REJECTED CHECK HERE _____ RETURN TO STEP 450	↓	
460	PHOTOGRAPH	TAKE DIGITAL PICTURES.		
470	AUDIT REVIEW	PROCESS DOCUMENT TO PROGRAM MANAGER FOR COMPLIANCE AUDIT.		
480	DOC. REVIEW	REVIEW DOCUMENTS AS REQUIRED IN CAF CHECKLIST, ALL DOCUMENTS NOTED TO BE ACCESSIBLE FOR AUDITING. (SHIPPER, C OF C, M.T.R., M.T.S., INSPECTION REPORT, X-RAY READER SHEETS AND HEAT TREAT CHARTS)		
NOTICE	RELEASE FROM EIO	PROVIDE DOCUMENTS TO EIO. SENT ON <u>6/25/05</u> BY <u>Chl</u> .	Q ENG OR QA MGR	
490	PACK AND SHIP	PACKAGE AND SHIP TO MAJOR TOOL.		
1000	REVISION HISTORY	ORIGINAL 12-14-04.	CARUUD	

EIO
Energy Industries of Ohio
SUPPLIER QUALITY RELEASE

C-2 Doc Package Document # 36

		Date: 6-27-05
--	--	---------------

I. General Information:		
Project Name:	Modular Coil Winding Form C2	
PO No:	NCSX-SOW-141-02-01	Rev.:
Supplier:	MetalTek	
Procurement Agent:	EIO	
Shipment:	<input checked="" type="checkbox"/> Partial <input type="checkbox"/> Final	

II. Material Description	
Casting C2 Coil	

III. Release Checklist	
Plan Requirements Complete?	<input checked="" type="checkbox"/> Yes <input type="checkbox"/> No <input type="checkbox"/> N/A (If identified "No" provide explanation in comments section below)
Variations?	<input checked="" type="checkbox"/> Yes <input type="checkbox"/> No <input type="checkbox"/> N/A (If identified "No" provide explanation in comments section below)
Princeton Notified of Shipment?	<input checked="" type="checkbox"/> Yes <input type="checkbox"/> No <input type="checkbox"/> N/A (If identified "No" provide explanation in comments section below)
DCMA Notified of Shipment?	<input checked="" type="checkbox"/> Yes <input type="checkbox"/> No <input type="checkbox"/> N/A (If identified "No" provide explanation in comments section below)
<input checked="" type="checkbox"/> Conditional <input checked="" type="checkbox"/> Unconditional	Explain conditional releases in comments section.

IV. Comments	
Variations – See attached package for CA's and deviations Dimensional report evaluated, adequate machine stock exists	

By signing below you acknowledge that the casting has met all applicable standards and contractual requirements

V. Supplier Quality Representative Sign Off		
Charles Ruud		6-27-05
Supplier Quality Representative (SQR) Print/Type Name	Supplier Quality Representative (SQR) Signature	Date

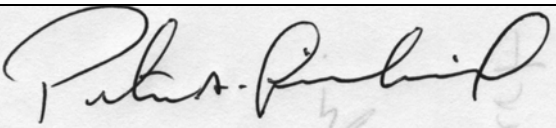
VI. Supplier Approval For Shipment		
Procurement Agent Notified of Shipment	Date: 6-27-05	
Required Vendor Data Ready for Shipment	Date: 6-27-05	
Peter A Djordjevich		6-27-05

EIO
Energy Industries of Ohio
SUPPLIER QUALITY RELEASE

C-2 Doc Package Document # 36
--

		Date: 6-27-05
--	--	---------------

I. General Information:		
Project Name:	Modular Coil Winding Form C2	
PO No:	NCSX-SOW-141-02-01	Rev.:
Supplier:	MetalTek	
Procurement Agent:	EIO	
Shipment:	<input checked="" type="checkbox"/> Partial <input type="checkbox"/> Final	
Supplier's Representative Print/Type Name	Supplier's Signature	Date

1. Enter:
Project Name
PO Number
Supplier
Procurement Agent
2. Enter a brief description of items being released, including applicable drawing number(s), dash or item number(s), drawing revision letter, specification(s), and serial number(s).
3. Self-Explanatory
4. Record any unusual circumstance, such as a conditional release.
5. The Supplier's representative shall sign and date.
7. Signature and date of the Supplier's authorized representative indicating shipping date.
8. In case of partial release, the supplier shall maintain copies of each sequential "Supplier Quality Release" and establish complete accountability of material release on final shipment.
9. Supplier shall include a copy of the completed form with each shipment.

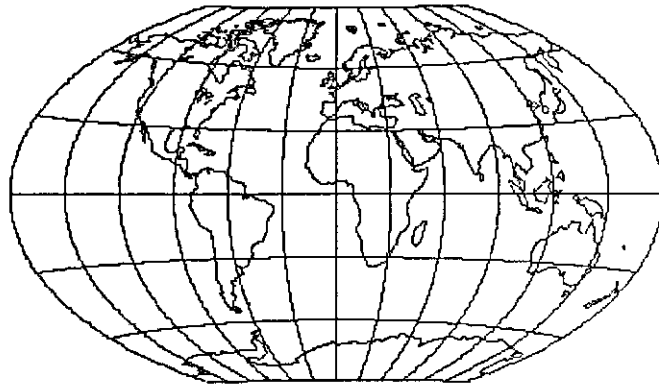

ENERGY INDUSTRIES OF OHIO

Purchase Order Number:

S005242-F

Part Number:

SE141-116

Part Name:

MCWF C-2

MODULAR COIL WINDING FORM

MTM Work Order Number:

65707/2.0



Major

Tool & Machine, Inc.

Table of Contents
 Quality Assurance Documents For
 Workorder: 65707/2.0

Page: 1
 Date: 02/13/06
 User ID: GRIFFIT#

Customer: 8909 - ENERGY INDUSTRIES OF OHIO
Customer P.O.: S005242-F
Customer Part ID: SE141-116 - MCWF C-2

Item#	Document Description / Material Description / File Name / Heat Lot
1	CERTIFICATE OF CONFORMANCE
2	COMPLETED SHOP TRAVELERS: - 65707-2 completed shop travelers.xls
3	NC18022 DISPOSITIONED: - NC-18022.pdf
4	NC18715 DISPOSITIONED: - NC18715_C2LinearIndications_121305.pdf
5	NC18812 DISPOSITIONED: - S52421 2-07-06 NCR 18812.pdf
6	NC18853 DISPOSITIONED: - NC18853_MetrologyDataGaps_121305.pdf
7	NC18864 DISPOSITIONED: - NC-18864 approval.pdf
8	RFD 14-011: - S52421 12-21-05 RFD 14-011.pdf

DS141-036 - STUD

Item#	Sub	Op	Pc	Document Description / Material Description / File Name / Heat Lot
9	4	10	30	Material Certification: TEST REPORTS / DS141-036 - STUD - mc108260.tif / 8969595

DS141-060 - NUT

Item#	Sub	Op	Pc	Document Description / Material Description / File Name / Heat Lot
10	4	10	50	Material Certification: / DS141-060 - NUT - mc108258.tif / 8977349

SE141-078 - POLOIDAL BREAK SHIM ASSEMBLY

Item#	Sub	Op	Pc	Document Description / Material Description / File Name / Heat Lot
11	2	30	20	Certificate of Conformance: POWDER CERT / LOCTITE 411 - LOCKING COMPOUND - mc106141.tif / CERTIFIED

SE141-078-03 - INSULATING SLEEVE

Item#	Sub	Op	Pc	Document Description / Material Description / File Name / Heat Lot
12	3	10	10	Certificate of Conformance: / G11CR_1 - ROUND, BAR, 1.75 DIA - mc108545.tif / CERTIFIED

SE141-103-1 - MOD COIL WINDING FORM ASSEMBLY TYPE-C

Item#	Sub	Op	Pc	Document Description / Material Description / File Name / Heat Lot
13	0	10	10	Material Certification: TRACE ID: 113686 / ER316MNNF_093_GTAW - WELD WIRE,GTAW .093 DIA - MC106164.PDF / W020132 / WO20132
14	0	10	10	Material Certification: TRACE ID: 116254 / ER316MNNF_093_GTAW - WELD WIRE,GTAW .093 DIA - MC106579.TIF / W020132 / WO20132

SE141-103-4 - INSULATING SHEET

Item#	Sub	Op	Pc	Document Description / Material Description / File Name / Heat Lot
15	7	10	10	Certificate of Conformance: G11CR / G11CR_3 - SHEET, FLAT - mc107081.tif / CERTIFIED

SE141-116 - MODULAR COIL WINDING FORM TYPE-C Qty: 1

Item#	Sub	Op	Pc	Document Description / Material Description / File Name / Heat Lot
16	1	20		Non-Conformance: 18022 Customer document: CUSTOMER DISPOSITIONED NCR - car04980.pdf
17	1	40		Inspection Data Checklist: 1 steps
18	1	100		Nondestructive Liquid Penetrant Test Certification #14648
19	1	110		Certification: RT INSPECTION (FILM MAILED) - MC114459.TIF

Customer: 8909 - ENERGY INDUSTRIES OF OHIO
 Customer P.O.: S005242-F
 Customer Part ID: SE141-116 - MCWF C-2

20	1	121	Inspection Data Checklist: 4 steps
21	1	134	Inspection Data Checklist: 132 steps
22	1	140	Inspection Data Checklist: 2 steps
23	16	20	Nondestructive Liquid Penetrant Test Certification #14900
24	14	10	Inspection Data Checklist: 3 steps
25	14	10	Photographs: PERMEABILITY MAP - MC114460.JPG
26	14	10	Photographs: PERMEABILITY MAP - MC114461.JPG
27	14	10	Photographs: PERMEABILITY MAP - MC114462.JPG
28	14	10	Photographs: PERMEABILITY MAP - MC114463.JPG

SE141-137 - BEARING PLATE

Item#	Sub	Op	Pc	Document Description / Material Description / File Name / Heat Lot
29	12	10	10	Material Certification: / 316_17 - BAR, FLAT, 1"X3", 316 SST - mc113978.tif / M11443
30	12	40		Inspection Data Checklist: 1 steps

SE141-138 - BEARING PLATE

Item#	Sub	Op	Pc	Document Description / Material Description / File Name / Heat Lot
31	13	10	10	Material Certification: / 316_17 - BAR, FLAT, 1"X3", 316 SST - Same as Item #29 / M11443
32	13	40		Inspection Data Checklist: 1 steps



TO: ENERGY INDUSTRIES OF OHIO

DATE: 12/07/2005

ATTENTION: Receiving Department

Seller certifies that:

Part Number: SE141-116	Purchase Order: S005242-F
Part Name: MCWF C-2	Workorder: 65707/2.0
Part Serial Number: 65707/ Lot 2.0	Quantity: 1

1. These materials and/or parts were produced in conformance with all contractually applicable Government and/or Customer specifications referred in, or furnished with, the above Purchase Order.
2. The materials and/or parts furnished under the above Purchase Order were produced:
 - From materials furnished by Customer for the production of such parts.
 - From materials for which the seller has available for examination chemical and/or physical test reports or other evidence of conformance to applicable specifications.
3. All processes required in the production of these part and/or materials are listed below and were performed by a facility or personnel approved or certified by the Seller and the customer when such approval or certification is required by contract.

Certifications are on file at this plant.

Other Requirements:

ALL REQUIRED CORRECTIONS
COMPLETED 12-12-05. *[Signature]*
S1501A
37 510-2058



Signature: *[Signature]* Title: Quality Man. Date: 12/12/05



Major

Tool & Machine, Inc.

Activity	Visual Mfg Ref.	Op Status	Close Date	Emp ID
Final inspection---Prepare part for source inspection.----Review and complete QA data package per QAP and the requirements of the product specification NCSX-CSPEC-141-03-05 September 23- 2004.--Contact CFT to review data package prior to notifying source inspection.	65707/2.0 -Sub:0 Op#:20	Closed	12/13/2005	840-G.Masood
Package and Ship---Build a box/crate suitable for protecting the part from the environment.---Weigh the finished part and metal stamp the value in pounds on the casting in the area marked on the customer drawing.----Part must be protected and wrapped in plastic prior to inserting into the crate. Refer to PS583.---Part is to be shipped to PPPL in Princeton- NJ per QAP shipping address.----Crate must be marked/stenciled per the MTM drawing.	65707/2.0 -Sub:0 Op#:40	Closed	12/14/2005	169-S.Williams
Receive customer supplied material. --Verify the receipt of quality documentation for the casting.--Check off IDC noting receipt of material and receipt of quality documentation.----Part Number: SE141-116 Rev: 7--Part Description: PRODUCTION WINDING FORM TYPE-C	65707/2.0 -Sub:1 Op#:10	Closed	12/12/2005	840-G.Masood
Setup the machining fixture on the rotary table. Load casting into the machining fixture with the initial pickup pads facing up. Indicate the pickup pads and orient the casting for machining. ---Rough machine the top flange face and the outer periphery leaving .25- +.060/- .000-. The outside surfaces of the flange will serve as qualifiers for the next operation. Record the qualifier dimensions on the IDC.---Install the lifting holes per the MTM drawing.----Rough machine the top side of the - T- section leaving .25- +.060/- .000-. ----Remove the casting from the machining fixture and flip over with the bottom flange facing up. Re-load into the machining fixture. Pickup the qualifiers and orient the casting for machining.----Rough machine the bottom flange face leaving .25- +.060/- .000-. ----Rough machine the poloidal break leaving a minimum of .25- of stock per side.----Install temporary shim filling in the poloidal break and hold together with temporary c-clamps. Tack weld in place.----Rough machine the bottom side of the - T- section leaving .25- +.060/- .000-.----Finish machine both sides of the entire casting with the	65707/2.0 -Sub:1 Op#:20	Closed	10/3/2005	713-M.Smith
Perform an in-process inspection of the magnetic permeability of the material using the Severn Permeability Indicator Gage. Inspect a minimum of (8) points on the rough machined flange face and an additional (8) points on the rough machined -T- section. Record the upper and lower range values on the IDC's. Values that exceed 1.02 must be documented with a non-conformance record and dispositioned prior to continuing.	65707/2.0 -Sub:1 Op#:40	Closed	12/12/2005	840-G.Masood



Major

Tool & Machine, Inc.

Activity	Visual Mfg Ref.	Op Status	Close Date	Emp ID
<p>Finish machine the -T- section and wings. Run a probe pass to inspect the surface for stock.----Remove the casting from the machining fixture and flip over with the bottom flange facing up. Re-load the casting into the machining fixture. Pickup the qualifiers and orient the casting for machining.----Finish machine the -T- section and wings. Run a probe pass to inspect the surface for stock.---- Obtain sketches SE141-116 FLATNESS D and SE141-116 FLATNESS E from the team leader. Use this sketch as a map and record indicator readings at each tooling ball location and near each point. Record information on the IDC prior to moving the part to the next workcenter.</p>	65707/2.0 -Sub:1 Op#:70	Closed	12/14/2005	591-C.Pritchett
<p>Setup the machining fixture with the casting installed. Machine the inspection fiducials per the MTM drawing. Finish machine the poloidal break to drawing requirements. Remove the casting from the machining fixture.----Install temporary shims in the poloidal break. Use the temporary shim 1.75 thick with additional shims as necessary and C-clamp before moving the part.</p>	65707/2.0 -Sub:1 Op#:80	Closed	12/14/2005	591-C.Pritchett
<p>Protect part from metal contamination due to contact with iron- specifically when rigging part for movement.----ALL GRINDING WHEELS AND DISKS MUST BE VIRGIN MATERIAL NOT PREVIOUSLY USED ON ANY MATERIAL TO AVOID MATERIAL CONTAMINATION.----Finish hand tapping of 3/8-16 holes using tap guide (if required)--Check spherical radius. Deburr as needed. See sheet 4-zn H-7--Start blending T-section--Hand grind 1/16 chamfer on all split line edges of poloidal break and on all thru holes at poloidal break.--Machinist to hand drill 1 cooling hole thru. See sheet 9 zone F-3. --Machinist to open up two 5/8 dia. holes to 1- dia. (see Carl Pritchett)--Hand grind VPI groove where required.-- Deburr wing areas to remove any roughness from machining (scallops do not need to be removed).--Check all accessible T clearances using MTMFX-3367 checking fixture--Hand grind 1/16 to 3/32 chamfer on outer edge of T in all accessible areas.--Grind plugs flush on back side of datum -E- flange.--Finish all other required deburring prior to flipping over part.--Move part to plant 2. Flip part and set up on datum -D.--Check spherical radius. Deburr as needed. See sheet</p>	65707/2.0 -Sub:1 Op#:85	Closed	11/23/2005	445-J.Purkhiser



Majer

Tool & Machine, Inc.

Activity	Visual Mfg Ref.	Op Status	Close Date	Emp ID
Protect part from metal contamination due to contact with iron- specifically when rigging part for movement.--Move part into wash booth. --Thoroughly clean and dry all surfaces and holes per section 9 of PS583. --Parts to be washed using heated- de-mineralized water- and if necessary- a mild non-chlorinated cleaning solution (e.g. Simple Green®- or authorized equivalent)- using MTM's high pressure washer. The spray pressure at the nozzle will be approximately 1-000 to 1-500 psi and the cleaning solution temperature will be approximately 150°F.	65707/2.0 -Sub:1 Op#:90	Closed	11/23/2005	219-T.Laird
PT 100% of the part as-cast surfaces as well as finished machine surfaces. See PS582 for processing instructions. During the inspection also perform a visual inspection of the casting surface per ASTM A802/A802M and accept per the same. Include reference to ASTM A802 on the certification.----Specification: ASTM A903/A903M----Method: ASTM E165----Acceptance Criteria: ASTM A903/A903M Level II for as cast surfaces----Acceptance Criteria: ASTM A903/A903M Level I for machined surfaces including the entire - T- section (high stress areas)----Certification: MTM certification to include the information per Supplementary Requirements S1 of ASTM A903/A903M--MTM NDT Cert: LPI CERTIFICATION	65707/2.0 -Sub:1 Op#:100 65707/2.0 -Sub:1 Op#:101	Closed Closed	12/12/2005 12/12/2005	840-G.Masood 840-G.Masood
The -T- areas defined as -High Stress- are to be RT 100%. See PS581 for process instructions.----Hand sketch a layout of all film locations on sheet (1) of the customer drawing SE141-116 rev. 2 to maintain shot and film traceability.----All film is to be doubled up in order to supply the customer with a complete set of film.----Specifications: ASTM A703/A703M Supplementary Requirement S5----Procedure/Method: ASTM E94 and ASTM E142 (use of a wire penetrometer may be necessary instead of the hole type to ensure objective 2% of thickness resolution/sensitivity)----Acceptance Criteria: No defect larger than .080- major dimension is allowed.----Scan RT certification- and hand sketched map and link in QAP to this operation.----Certification: RADIOGRAPHIC INSPECTION--Map(s): CUSTOMER DRAWING Rev: --Part Number: SE141-116 Rev: 7 --Part Description: WINDING FORM TYPE-C--Material Type: 316 SST--Material Thickness: VARIES--Serial Number: C-2	65707/2.0 -Sub:1 Op#:110 65707/2.0 -Sub:1 Op#:111	Closed Closed	12/13/2005 12/12/2005	933-D.Leapley 840-G.Masood
SOURCE FOR RT				



Major

Tool & Machine, Inc.

Activity	Visual Mfg Ref.	Op Status	Close Date	Emp ID
Protect part from metal contamination due to contact with iron- specifically when rigging part for movement.--Load part on CMM table and move into quality lab. See quality personnel for setup information.	65707/2.0 -Sub:1 Op#:115	Closed	11/28/2005	219-T.Laird
Inspect poloidal break features and complete IDC's.	65707/2.0 -Sub:1 Op#:121	Closed	11/22/2005	212-J.Lehr
Install the poloidal break shim assembly and accompanying hardware and insulation per the assembly drawing.-- Torque hardware to 500 ft-lbs.	65707/2.0 -Sub:1 Op#:130	Closed	11/25/2005	219-T.Laird
Inspect the part 100% per the drawing requirements. Refer to PS593.--Surface profile dimensions are to be taken on a 2- x 2- grid for machined surfaces and 4- x 4- grid for as cast surfaces.--Inspect fiducials that are located around the periphery of both flanges. --Record dimensions as required per the IDC's.--If surface finish is rejected- the nonconforming areas must be mapped on a drawing for submittal to the customer.--Forward and IGES file of the 2 x 2 and 4 x 4 grid points as well as points representing the locations of the inspection fiducials to Kevin Bowling for reporting to the customer.	65707/2.0 -Sub:1 Op#:134	Closed	12/12/2005	840-G.Masood
SOURCE FOR DIMENSIONAL	65707/2.0 -Sub:1 Op#:138	Closed	12/12/2005	840-G.Masood
Perform electrical resistance test.----Wire all of the bolts together. Set one jumper directly on casting flange and one on the bolts. Record resistance between the bolt and casting combination and the mid-plane shim in kohms on IDC.----Set a jumper between the poloidal joint midplane and the casting. Set one jumper on the poloidal joint midplane and one on each of the bolts. Record range of resistance in kohms on IDC.	65707/2.0 -Sub:1 Op#:140	Closed	12/12/2005	840-G.Masood
SOURCE FOR ELECTRICAL TEST	65707/2.0 -Sub:1 Op#:150	Closed	12/12/2005	840-G.Masood
WELD REPAIR TOOL GOUGE.--PERFORM LOCAL DYE CHECK. FORMAL PT WILL BE DONE ON THE FULL PART LATER.--	65707/2.0 -Sub:8 Op#:10	Closed	9/24/2005	352-J.Spencer
See sheet 5- Zone E8; 1.375-6 UNC and 1.88 diameter thru holes.--Indicate in the 1.375-6 tapped hole and bore out to 1.500 +.000/--.001-. Bore hole to a depth of 1.850- +/- .005 from datum -E- flange. Machine a .060- chamfer to be used as a wled prep. ----Indicate in the 1.88 diameter hole and bore to 1.900- +.000/--.001-. Machine a .060- chamfer to be used as a wled prep.	65707/2.0 -Sub:10 Op#:10	Closed	11/14/2005	591-C.Pritchett



Major

Tool & Machine, Inc.

Activity	Visual Mfg Ref.	Op Status	Close Date	Emp ID
Freeze each plug and insert into hole. --The 1.5 diameter plug should bottom out in bored hole leaving approx. .050- above the flange.--Install the 1.9- diameter plug flush against the bottom of the flange. There should be at least .050- beyond the top surface of the flange in order to have machining stock to ensure a full clean up.--Grind prep on each plug to achieve an 1/8- - 3/16- fillet. Weld complete.	65707/2.0 -Sub:10 Op#:20	Closed	11/14/2005	352-J.Spencer
Skim datum -E- flange to blend reworked areas.---Machine 1.375-6 UNC tapped hole per location on drawing. Drill hole to achieve an 1.25- tap depth. NOTE: Hole will no be thru as indicated on the drawing.----Bore 1.88 thru as indicated on drawing.	65707/2.0 -Sub:10 Op#:30	Closed	11/14/2005	591-C.Pritchett
SAW 2 PLUGS FROM CUSTOMER SUPPLIED MATERIAL (300 SERIES STAINLESS).--SEE ROB BACHEK OR DAN EDWARDS FOR SPECIFIC SIZES AND METHOD.--PLUGS SHOULD BE APPROXIMATELY 2.2- SQUARE BY 4- LONG.	65707/2.0 -Sub:11 Op#:10	Closed	11/8/2005	227-D.Bockover
Machine plugs to the following:--1st piece:--Turn/Mill O.D. to 1.501 +.001/--.000. Length of plug to be 1.910- +/- .010. ----2nd piece:--Turn/Mill O.D. to 1.901 +.001/--.000. Length of plug to be 1.600- +/- .010.	65707/2.0 -Sub:11 Op#:20	Closed	11/13/2005	565-S.Woods
RECEIVE CUSTOMER SUPPLIED CASTING	65707/2.0 -Sub:2 Op#:10	Closed	10/3/2005	437-J.Hiatt
DO NOT MACHINE...UNRELEASED DUE TO PART GEOMETRY CHANGES.--MACHINE THE SHIM COMPLETE PER THE DRAWING AND CNC PROGRAMS.	65707/2.0 -Sub:2 Op#:20	Closed	10/6/2005	506-R.Liston
ASSEMBLE (5) OF THE INSULATING SLEEVES INTO THE SHIM AND BOND USING LOCTITE 411. DO NOT INSTALL THE BUSHINGS IN THE OUTSIDE HOLES. THEY WILL BE INSTALLED LATER.	65707/2.0 -Sub:2 Op#:30	Closed	11/25/2005	219-T.Laird
SAW OFF 16- AND MOVE TO NEXT WORK CENTER.	65707/2.0 -Sub:3 Op#:10	Closed	6/1/2005	227-D.Bockover
MACHINE PER THE DRAWING FOR A SLIP FIT WITH MATING DETAIL. OBTAIN FINISHED MACHINED CASTING SHIM BEFORE FINAL SIZING THE O.D. OF THE SLEEVE.	65707/2.0 -Sub:3 Op#:20	Closed	11/22/2005	821-J.Leggins
RECEIVE MATERIAL--NOTIFY CFT AND FORWARD MATERIAL STORES.	65707/2.0 -Sub:4 Op#:10	Closed	5/19/2005	825-B.Jarrett
SAW OFF 30- LENGTH AND MOVE TO NEXT WORK CENTER.	65707/2.0 -Sub:5 Op#:10	Closed	6/1/2005	227-D.Bockover
MACHINE PER THE DRAWING FOR A SLIP FIT WITH MATING DETAIL. CHECK FINISHED MACHINED CASTING BEFORE FINAL SIZING THE O.D. OF THE SLEEVE.	65707/2.0 -Sub:5 Op#:20	Closed	11/23/2005	565-S.Woods
SAW 13- LENGTH AND MOVE TO NEXT WORK CENTER.	65707/2.0 -Sub:6 Op#:10	Closed	6/1/2005	227-D.Bockover



Major

Tool & Machine, Inc.

Activity	Visual Mfg Ref.	Op Status	Close Date	Emp ID
UNRELEASED DO NOT PERFORM THIS OPERATION DUE TO PRODUCT CHANGES THIS PART HAS BEEN ELIMINATED FROM THE ASSEMBLY. RECEIVE MATERIAL	65707/2.0 -Sub:6 Op#:20 65707/2.0 -Sub:7 Op#:10	Closed Closed	4/5/2005	131-W.Allen
MACHINE THE PROFILE LEAVING STOCK PER PROGRAM.---ALSO MACHINE OUT FLAT STOCK PIECES FOR SHIMS BEHIND THE OUTSIDE OF POLOIDAL BREAK FLANGE PER CNC PROGRAM.	65707/2.0 -Sub:7 Op#:20	Closed	9/14/2005	129-E.Taina
PERFORM A MAGNETIC PERMEABILITY CHECK ON THE RAW MATERIAL USING A SEVERN PERMEABILITY INDICATOR GAGE. PERMEABILITY SHOULD BE LESS THAN 1.02µ.	65707/2.0 -Sub:12 Op#:10	Closed	11/21/2005	503-B.Houk
SAW TO A LENGTH OF 6.75.	65707/2.0 -Sub:12 Op#:20	Closed	11/21/2005	261-T.Dunn
MACHINE COMPLETE PER PRINT.	65707/2.0 -Sub:12 Op#:30	Closed	11/22/2005	296-D.Stallsworth
PER DRAWING NOTE 5:--PERFORM A MAGNETIC PERMEABILITY CHECK USING A SEVERN PERMEABILITY INDICATOR GAGE. PERMEABILITY SHOULD BE LESS THAN 1.02µ.--Part Number: SE141-137--Part Description: BEARING PLATE DETAIL	65707/2.0 -Sub:12 Op#:40	Closed	11/23/2005	503-B.Houk
PERFORM A MAGNETIC PERMEABILITY CHECK ON THE RAW MATERIAL USING A SEVERN PERMEABILITY INDICATOR GAGE. PERMEABILITY SHOULD BE LESS THAN 1.02µ.	65707/2.0 -Sub:13 Op#:10	Closed	11/21/2005	503-B.Houk
SAW TO A LENGTH OF 10.5.	65707/2.0 -Sub:13 Op#:20	Closed	11/21/2005	261-T.Dunn
MACHINE COMPLETE PER PRINT	65707/2.0 -Sub:13 Op#:30	Closed	11/23/2005	502-D.Larsen
PER DRAWING NOTE 5:--PERFORM A MAGNETIC PERMEABILITY CHECK USING A SEVERN PERMEABILITY INDICATOR GAGE. PERMEABILITY SHOULD BE LESS THAN 1.02µ.--Part Number: SE141-138--Part Description: BEARING PLATE DETAIL	65707/2.0 -Sub:13 Op#:40	Closed	12/14/2005	840-G.Masood



Major

Tool & Machine, Inc.

Activity	Visual Mfg Ref.	Op Status	Close Date	Emp ID
<p>This operation is to be performed concurrent to the CMM inspection.--Inspect the magnetic permeability of the entire casting using the Severn Permeability Indicator Gage. Refer to PS584. All as cast surfaces must be inspected on a 6- x 6- grid. Record range of actual values on IDC. All machined surfaces must be inspected on a 2- x 2- grid. Record range of actual values on IDC. Permeability measurements shall be per supplementary requirements S24 of ASTM A703/A703M and S1 of ASTM A800/800M except the results will be expressed as relative permeability (μ) rather than ferrite content (FN). Values that exceed 1.02 must be documented with a non-conformance record and dispositioned prior to continuing.-- Take digital photos of the grid layout on part for customer data package. Link photos to QAP and also forward photos to engineering.--Part Number: SE141-116 Rev: 7--Part Description: MODULAR COIL WINDING FORM --Photographs: PERMEABILITY MAP--Photographs: PERMEABILITY MAP MAP--Photographs: PERMEABILITY MAP--Photographs: PERMEABILITY MAP SOURCE FOR MAG PERMEABILITY</p>	<p>65707/2.0 -Sub:14 Op#:10 65707/2.0 -Sub:14 Op#:20</p>	<p>Closed Closed</p>	<p>12/12/2005 12/12/2005</p>	<p>840-G.Masood 840-G.Masood</p>
<p>PERFORM A LOCAL LPI CHECK OF THE 3 PREVIOUSLY REJECTED AREAS. THERE WAS 1 REJECTION ON THE MACHINED T AND 2 REJECTIONS IN THE AS-CAST REGION.----Specification: ASTM A903/A903M- ---Method: ASTM E165----Acceptance Criteria: ASTM A903/A903M Level II for as cast surfaces----Acceptance Criteria: ASTM A903/A903M Level I for machined surfaces including the entire -T- section (high stress areas)---- Certification: MTM certification to include the information per Supplementary Requirements S1 of ASTM A903/A903M--MTM NDT Cert: LPI</p>	<p>65707/2.0 -Sub:16 Op#:20</p>	<p>Closed</p>	<p>12/12/2005</p>	<p>840-G.Masood</p>

Major Tool & Machine, Inc.
1458 East 19th Street
Indianapolis, IN 46218-4289

MTM N/C: 18022

Page: 1
Date: 08/30/05
User ID: BOWLING

Customer: ENERGY INDUSTRIES OF OHIO
Contact: NANCY HORTON
E-Mail: NKHFlowen@aol.com

Telephone: 216-496-2314
Fax: 216-328-2001

Part: /
Drawing ID: SE141-116

Revision: 6

Customer P.O.: S005242-F/Ln:2
Serial No./Qty: C2

Reported By: KEVIN BOWLING
E-Mail: kBowling@MajorTool.com

Telephone: 317-636-6433
Fax: 317-634-9420

Problem: 1. Tool gouge in T-Section. See photograph for location. 2. Hole is oversize at the outside face approx. .125" deep.

Proposed Disposition:

1. Weld build up tool gouged area and re-machine. 2. Install .18 x 45° chamfer on the hole.

Number of additional pages: _____

Customer Disposition: Use As Is Rework Repair Scrap Replace

Agree with proposed disposition.

Approved:

~~PPPL Tech. Representative~~
2005.09.12 11:08:21 -04'00'
PPPL Tech. Representative

Digitally signed by Brad Nelson
DN: cn=Brad Nelson, o=Major Tool & Machine, c=US,
email=brad.nelson@mtm.com, serial=230606, date=2005.09.12 11:44:06 -04'00'
Brad Nelson
Responsible Line Manager

Major Tool Implemented By: 

Title: Process Engineer Date: 12/2/05

n:\mtmapps\Mtnonc14.qrp

Major Tool and Machine, Inc. 1458 East 19th Street, Indianapolis, IN 46218-4289 Tel: 317-636-6433 Fax: 317-634-9420

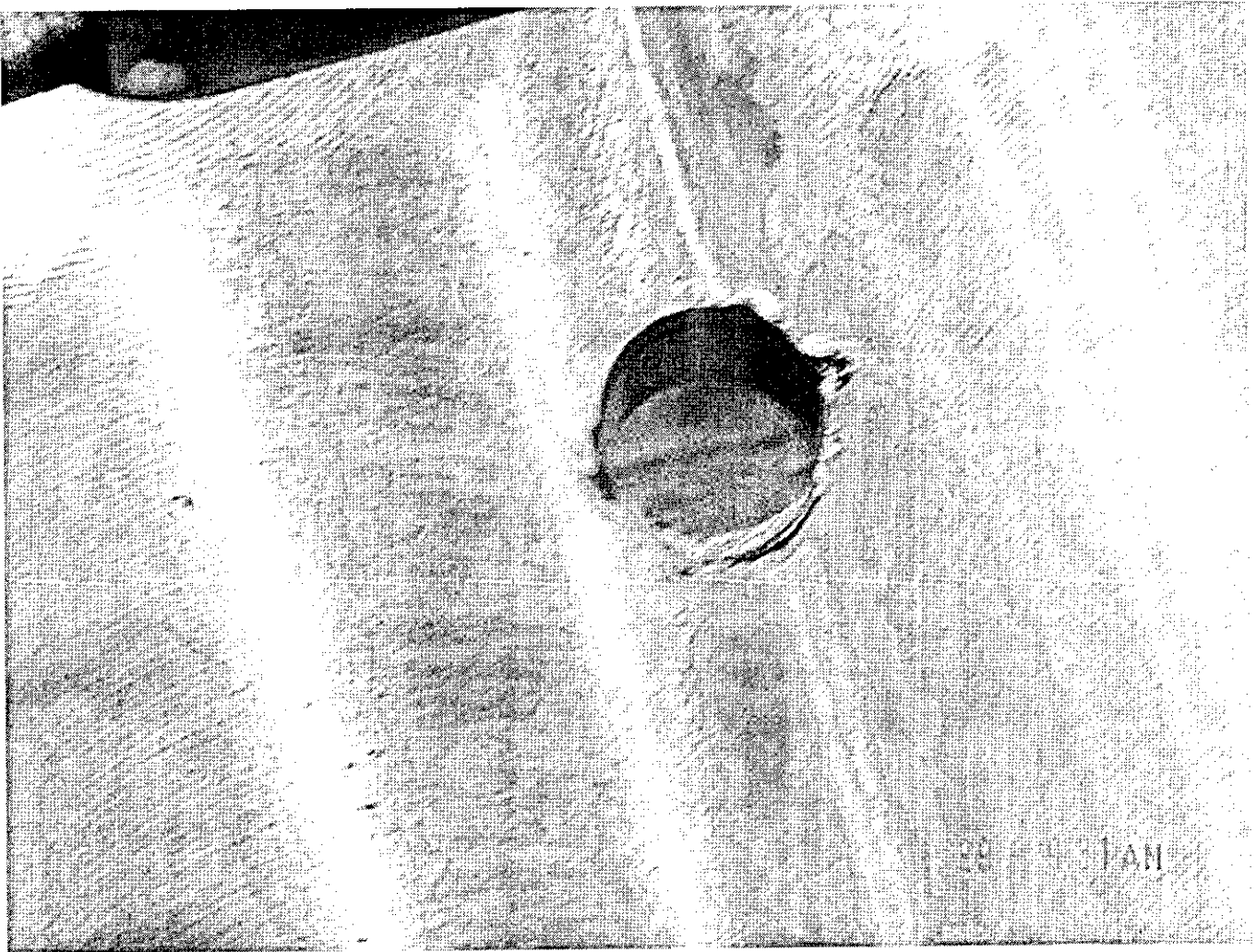



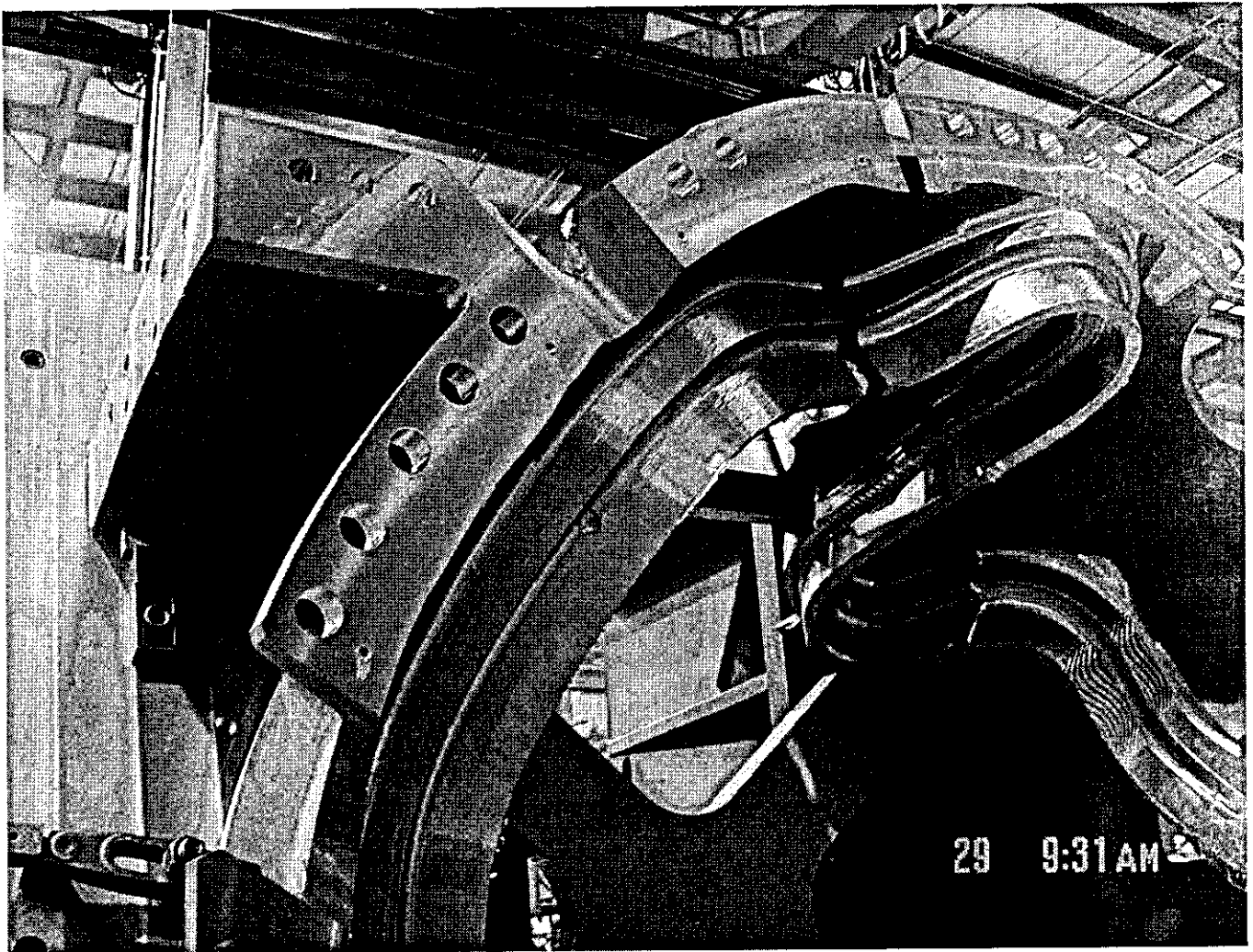

Complete signed copy of NCI8715 is on file with PPPL

Major Tool & Machine, Inc.
1458 East 19th Street
Indianapolis, IN 46218-4289

MTM N/C: 18715

Page: 1
Date: 12/13/05
User ID: BOWLING

Customer: ENERGY INDUSTRIES OF OHIO

Contact: NANCY HORTON
E-Mail: NKHFlowen@aol.com

Telephone: 216-496-2314
Fax: 216-328-2091

Part: SE141-116/MODULAR COIL WINDING FORM TYPE
Drawing ID: SE141-116 Revision: 6

Customer P.O.: S005242-F Lot 2
Serial No. Qty: C2

Reported By: MIKE GRIFFITH
E-Mail: mGriffith@MajorTool.com

Telephone: 317-636-6433
Fax: 317-634-9426

Problem: NON-CONFORMANCE 1

PART IS REJECTED PER ASTM A903/A903M Level I. INDICATION IS V-SHAPED AND IS APPROXIMATELY .450" IN LENGTH ON THE LONGEST LEG (SEE PICTURES). INDICATION IS ON THE THIN SECTION OF THE T, LOCATED BETWEEN HOLES 84 AND 85. SEE ACCOMPANYING PHOTOS.

NON-CONFORMANCE 2

PART IS ALSO REJECTED PER ASTM A903/A903M LEVEL II. INDICATIONS ARE JUST OVER THE ACCEPTABLE SIZE RANGE. SEE ACCOMPANYING PHOTOS.

Proposed Disposition:

CUSTOMER TO ADVISE.

Number of additional pages: _____

Customer Disposition: Use As Is Rework Repair Scrap Replace

This NCR refers to MCWF C2. Please see Attachment I for backup data for this disposition.

Tech. Rep. Approval:

Phil
Heitzenroeder

Digitally signed by Phil Heitzenroeder
DN: cn=Phil Heitzenroeder, o=US,
ou=PPPL, ou=Mech. Eng. Division
Reason: I agree to the terms defined
by the placement of my signature on
this document.
Date: 2005.12.13 12:09:08 -0500

RLM Approval:

Brad
Nelson

Digitally signed by Brad Nelson
DN: cn=Brad Nelson, o=US,
ou=ORNL, ou=FED,
email=nelsonbs@ornl.gov
Date: 2005.12.13 12:32:16
-0500

Non-conformance 1

Major Tool Implemented By: _____ Title: _____ Date: _____

major@pppl.com

Major Tool and Machine, Inc. 1458 East 19th Street, Indianapolis, IN 46218-4289 Tel: 317-636-6433 Fax: 317-634-9426

Customer: ENERGY INDUSTRIES OF OHIO

Contact: NANCY HORTON
E-Mail: NKHFlowen@aol.com

Telephone: 216-496-2314
Fax: 216-328-2001

Part: /
Drawing ID: SE141-116

Revision: 7

Customer P.O.: S005242-F/Ln:2
Serial No./Qty: C2

Reported By: MIKE GRIFFITH
E-Mail: mGriffith@MajorTool.com

Telephone: 317-636-6433
Fax: 317-634-9420

Problem: Workorder: 65707/2.0 Sub:1 Op:134

Inspection Test #: 140 rejected: P TO M: {g|.1|R|S|T}: REFERENCE IGES DATA
Inspection Test #: 180 rejected: M TO N: {g|.02|R|S|T}: REFERENCE IGES DATA
Inspection Test #: 190 rejected: 96X
Ø.375-16 UNC .188 DEEP
C'BORE Ø.625 AS SHOWN: {#.01|R|S|T}: .077 POSITION / ACCEPT THREAD / .624 CBORE
Inspection Test #: 210 rejected: 8X Ø1-8 UNC THRU: {#.01|A|B|C}: .038
Inspection Test #: 230 rejected: : {f|.01}: 0.020
Inspection Test #: 250 rejected: : {f|.01}: 0.016
Inspection Test #: 260 rejected: : R76.00: 75.750 - 75.925
Inspection Test #: 270 rejected: : R73.70: 73.723
Inspection Test #: 280 rejected: 8X
Ø1.13 THRU
BACK SPOT FACE Ø2.38
MIN DEPTH FOR C'UP: {#.01|A|B|C}: .027 / 1.12 - 1.13 / ACCEPT SPOT
Inspection Test #: 290 rejected: 3X Ø1.88 THRU
Ø3.00 BACK SPOTFACE
MIN TO CLEANUP: {#.010|D|A|N}: .027 / 1.87 - 1.88 / ACCEPT CLEAN UP
Inspection Test #: 295 rejected: 3 X SPHERICAL R.750 +.002 / -.003
TOLERANCE CHANGE PER
RFD 14-009 ITEM 5.
DATUM -D- FLANGE.: : .753 / .764 / .763
Inspection Test #: 300 rejected: 3X SPH R.75 TO .75 DEEP: {#|d.01|D|A|N}: TP .020 / .74 DEEP
Inspection Test #: 310 rejected: 17X Ø1.88 THRU
Ø3.00 BACK SPOTFACE
MIN TO CLEANUP: {#|d.01|D|A|N}: 0.102 / 1.87 - 1.88 / 3.00 CLEAN UP
Inspection Test #: 320 rejected: 3X Ø1.13
Ø2.38 BACK SPOTFACE
MIN TO CLEANUP: {#|d.01|D|A|N}: 0.041 / 1.12 - 1.13 / 3.2 CLEAN UP
Inspection Test #: 340 rejected: 3X Ø1.375-6 UNC THRU: {#|d.01|D|A|N}: .038 / ACCEPT THREADS
Inspection Test #: 350 rejected: 5X Ø1.88 THRU
Ø3.00 BACK SPOTFACE
MIN TO CLEANUP: {#|d.01|D|A|N}: .0182 / 1.87 - 1.88 / 2.98 - 2.99
Inspection Test #: 360 rejected: Ø1.88 THRU
Ø3.00 BACK SPOTFACE
MIN TO CLEANUP: {#|d.01|D|A|N}: .0184 / 1.88 / 2.99
Inspection Test #: 370 rejected: 3X Ø1.13
Ø2.38 BACK SPOTFACE
MIN TO CLEANUP: {#|d.01|D|A|N}: .028 / 1.13 - 1.27 / 3.2 CLEAN UP
Inspection Test #: 380 rejected: Ø1.88 THRU
Ø3.00 BACK SPOTFACE
MIN TO CLEANUP: {#|d.01|E|A|J}: .015
Inspection Test #: 410 rejected: 3X SPH R.75 TO .75 DEEP
: {#|d.01|E|A|J}: TP .0172
Inspection Test #: 430 rejected: 24X Ø1.88 THRU
Ø3.00 BACK SPOTFACE

e:\mtmapps\lmonc14.qrp

MIN TO CLEANUP: {#|d.01|E|A|J}: .070 / 3.00 CLEANUP
Inspection Test #: 440 rejected: 3X Ø1.5 TO 2.00 DEEP
Ø3.00 TO 1.00 DEEP: {#|d.01|E|A|J}: .051 / 2.99 / 1.00 DEEP
Inspection Test #: 630 rejected: : R4.00 ~ .010: 3.90
Inspection Test #: 650 rejected: : 4.00 ~ .010: 3.97
Inspection Test #: 670 rejected: : R4.00 ~ .010: 3.98
Inspection Test #: 710 rejected: : d8.00 ~ .010: 7.990-8.265 (0.275 OOR)
Inspection Test #: 760 rejected: : 13.6 ~ 13.20
Inspection Test #: 770 rejected: : 5.88 ~ .010: PAD BLENDS INTO CAST SUFACE
Inspection Test #: 780 rejected: : 2.19 ~ .010: 2.1
Inspection Test #: 790 rejected: : 2.19 ~ .010: 2.17
Inspection Test #: 800 rejected: : 4X R.50: BOTTOM RADII BLEND INTO CAST SURFACE
Inspection Test #: 880 rejected: : d8.00 ~ .010: 7.980-8.265 0.075 OOR
Inspection Test #: 990 rejected: : {g|.5|A|B|C}: REFERENCE IGES DATA
Inspection Test #: 1000 rejected: : {g|.02|R|T|S}: REFERENCE IGES DATA
Inspection Test #: 1020 rejected: : {g|.02|R|T|S}: REFERENCE IGES DATA
Inspection Test #: 1030 rejected: : {g|.5|A|B|C}: REFERENCE IGES DATA
Inspection Test #: 1070 rejected: : 47.79 ~ .010: 47.776
Inspection Test #: 1100 rejected: : 80.49: 80.469
Inspection Test #: 1110 rejected: : 87.87 ~ .010: 87.838
Inspection Test #: 1120 rejected: : 89.64 ~ .010: 89.584
Inspection Test #: 1150 rejected: : 11.48 ~ .010: 11.463
Inspection Test #: 1290 rejected: : 88.39 ~ .010: 88.371
Inspection Test #: 1320 rejected: : 28.71 ~ .010: 28.721
Inspection Test #: 1340 rejected: : 22.117 ~ .005: 22.109
Inspection Test #: 1350 rejected: : 38.14 ~ .010: 38.152
Inspection Test #: 1380 rejected: : 7.53 ~ .010: 7.555
Inspection Test #: 1390 rejected: : 4.91 ~ .010: 4.879

Proposed Disposition:
CUSTOMER TO ADVISE ON ACCEPTABILITY OF DIMENSIONAL INSPECTION.

Number of additional pages: _____

Customer Disposition: Use As Is Rework Repair Scrap Replace

Dimensional discrepancies were evaluated per attached list and found to be acceptable.

Technical Rep. Approval:

Phil
Heitzenroeder

Digitally signed by Phil Heitzenroeder
DN: cn = Phil Heitzenroeder, c = US, o =
PPPL, ou = Mech. Eng. Division
Reason: I agree to the terms defined by
the placement of my signature on this
document.
Date: 2005.12.13 14:36:31 -0500

RLM Approval: Brad
Nelson

Digitally signed by Brad Nelson
DN: cn=Brad Nelson, c=US,
o=ORNL, ou=FED,
email=nelsonbe@ornl.gov
Date: 2005.12.14 09:24:26
-0500

Major Tool Implemented By: _____

Title: _____

Date: _____

Inspection Test #: 140 rejected: P TO M: {g|.1|R|S|T}: REFERENCE IGES DATA
 OK PER EVALUATION BY T. BROWN / S. RAFTOPOLOUS
 Inspection Test #: 180 rejected: M TO N: {g|.02|R|S|T}: REFERENCE IGES DATA
 OK PER EVALUATION BY T. BROWN / S. RAFTOPOLOUS
 Inspection Test #: 190 rejected: 96X Ø.375-16 UNC .188 DEEP C'BORE Ø.625 AS SHOWN: {#|.01|R|S|T}: .077 POSITION /
 ACCEPT THREAD / .624 CBORE
 OK, C2 TEE HOLE POSITION IS OUT .077 MAX, BETTER THAN C1 (.165 MAX)
 Inspection Test #: 210 rejected: 8X Ø1-8 UNC THRU: {#|.01|A|B|C}: .038
 OK, POSITION TOLERANCE SIMILAR TO C1, THIS IS A CLEARANCE HOLE W/ BUSHING
 Inspection Test #: 230 rejected: : {f|.01}: 0.020
 OK, FLATNESS TOL FOR FLANGE DATUM-E SIMILAR TO C1
 Inspection Test #: 250 rejected: : {f|.01}: 0.016
 OK, FLATNESS TOL FOR FLANGE DATUM-D SIMILAR TO C1
 Inspection Test #: 260 rejected: : R76.00: 75.750 - 75.925
 OK, INNER RADIUS OF OUTER TF SHELF, INTERFACE NOT CRITICAL
 Inspection Test #: 270 rejected: : R73.70: 73.723
 OK, OUTER RADIUS OF OUTER TF SHELF, INTERFACE NOT CRITICAL
 Inspection Test #: 280 rejected: 8X Ø1.13 THRU BACK SPOT FACE Ø2.38 MIN DEPTH FOR C'UP: {#|.01|A|B|C}: .027 / 1.12 -
 1.13 / ACCEPT SPOT
 OK, C2 HOLE POSITION IS OUT .027 MAX, BETTER THAN C1 (.054 MAX)
 Inspection Test #: 290 rejected: 3X Ø1.88 THRU Ø3.00 BACK SPOTFACE MIN TO CLEANUP: {#|.010|D|A|N}: .027 / 1.87 - 1.88
 / ACCEPT CLEAN UP
 OK, THIS IS A CLEARANCE HOLE W/ BUSHING
 Inspection Test #: 295 rejected: 3 X SPHERICAL R.750 +.002 / -.003 TOLERANCE CHANGE PER RFD 14-009 ITEM 5. DATUM
 -D- FLANGE.: : .753 / .764 / .763
 DISCUSS WITH PPPL, NUMBERS ARE DIFFERENT ON CHECKLIST (.758/.752/.750)
 Inspection Test #: 300 rejected: 3X SPH R.75 TO .75 DEEP: {#|d.01|D|A|N}: TP .020 / .74 DEEP
 DISCUSS WITH PPPL
 Inspection Test #: 310 rejected: 17X Ø1.88 THRU Ø3.00 BACK SPOTFACE MIN TO CLEANUP: {#|d.01|D|A|N}: 0.102 / 1.87 -
 1.88 / 3.00 CLEAN UP
 LARGEST POSITIONAL ERROR, CHECK IGES DATA FOR LOCATION, NUMBER, DISCUSS
 Inspection Test #: 320 rejected: 3X Ø1.13 Ø2.38 BACK SPOTFACE MIN TO CLEANUP: {#|d.01|D|A|N}: 0.041 / 1.12 - 1.13 / 3.2
 CLEAN UP
 OK, C2 HOLE POSITION IS OUT .041 MAX, BETTER THAN C1 (.054 MAX)
 Inspection Test #: 340 rejected: 3X Ø1.375-6 UNC THRU: {#|d.01|D|A|N}: .038 / ACCEPT THREADS
 OK, SAME POSITION ERROR AS THRU HOLES, MATES CLEARANCE HOLE W/ BUSHING
 Inspection Test #: 350 rejected: 5X Ø1.88 THRU Ø3.00 BACK SPOTFACE MIN TO CLEANUP: {#|d.01|D|A|N}: .0182 / 1.87 -
 1.88 / 2.98 - 2.99
 OK, THIS IS A CLEARANCE HOLE W/ BUSHING
 Inspection Test #: 360 rejected: Ø1.88 THRU Ø3.00 BACK SPOTFACE MIN TO CLEANUP: {#|d.01|D|A|N}: .0184 / 1.88 / 2.99
 OK, THIS IS A CLEARANCE HOLE W/ BUSHING
 Inspection Test #: 370 rejected: 3X Ø1.13 Ø2.38 BACK SPOTFACE MIN TO CLEANUP: {#|d.01|D|A|N}: .028 / 1.13 - 1.27 / 3.2
 CLEAN UP
 OK, C2 HOLE POSITION IS OUT .028 MAX, BETTER THAN C1 (.054 MAX)
 Inspection Test #: 380 rejected: Ø1.88 THRU Ø3.00 BACK SPOTFACE MIN TO CLEANUP: {#|d.01|E|A|J}: .015 (positional
 error)
 OK, THIS IS A CLEARANCE HOLE W/ BUSHING
 Inspection Test #: 410 rejected: 3X SPH R.75 TO .75 DEEP : {#|d.01|E|A|J}: TP .0172
 OK, FEATURE LOCATION ESTABLISHED BY ROMER PRIOR TO ASSEMBLY
 Inspection Test #: 430 rejected: 24X Ø1.88 THRU Ø3.00 BACK SPOTFACE MIN TO CLEANUP: {#|d.01|E|A|J}: .070 / 3.00
 CLEANUP
 OK, THIS IS A CLEARANCE HOLE W/ BUSHING
 Inspection Test #: 440 rejected: 3X Ø1.5 TO 2.00 DEEP Ø3.00 TO 1.00 DEEP: {#|d.01|E|A|J}: .051 / 2.99 / 1.00 DEEP
 OK, FEATURE LOCATION ESTABLISHED BY ROMER PRIOR TO ASSEMBLY
 Inspection Test #: 630 rejected: : R4.00 ~ .010: 3.90
 OK, DIM REFERENCES PORT OPENING, LARGE CLEARANCE
 Inspection Test #: 650 rejected: : 4.00 ~ .010: 3.97
 OK, DIM REFERENCES PORT OPENING, LARGE CLEARANCE
 Inspection Test #: 670 rejected: : R4.00 ~ .010: 3.98
 OK, DIM REFERENCES PORT OPENING, LARGE CLEARANCE
 Inspection Test #: 710 rejected: : d8.00 ~ .010: 7.990-8.265 (0.275 OOR)
 OK, DIM REFERENCES PORT OPENING, LARGE CLEARANCE

Consider changing tolerance

Inspection Test #: 760 rejected: : 13.6 ~ 13.20
 OK, DIM REFERENCES LEADS AREA
 Inspection Test #: 770 rejected: : 5.88 ~ .010: PAD BLENDS INTO CAST SUFACE
 OK, DIM REFERENCES LEADS AREA
 Inspection Test #: 780 rejected: : 2.19 ~ .010: 2.1
 OK, DIM REFERENCES LEADS AREA
 Inspection Test #: 790 rejected: : 2.19 ~ .010: 2.17
 OK, DIM REFERENCES LEADS AREA
 Inspection Test #: 800 rejected: : 4X R.50: BOTTOM RADII BLEND INTO CAST SURFACE
 OK, DIM REFERENCES LEADS AREA
 Inspection Test #: 880 rejected: : d8.00 ~ .010: 7.980-8.265 0.075 OOR
 OK, DIM REFERENCES PORT OPENING, LARGE CLEARANCE
 Inspection Test #: 990 rejected: : {gl.5|A|B|C}: REFERENCE IGES DATA
 OK PER EVALUATION BY T. BROWN / S. RAFTOPOLOUS
 Inspection Test #: 1000 rejected: : {gl.02|R|T|S}: REFERENCE IGES DATA
 OK PER EVALUATION BY T. BROWN / S. RAFTOPOLOUS
 Inspection Test #: 1020 rejected: : {gl.02|R|T|S}: REFERENCE IGES DATA
 OK PER EVALUATION BY T. BROWN / S. RAFTOPOLOUS
 Inspection Test #: 1030 rejected: : {gl.5|A|B|C}: REFERENCE IGES DATA
 OK PER EVALUATION BY T. BROWN / S. RAFTOPOLOUS
 Inspection Test #: 1070 rejected: : 47.79 ~ .010: 47.776
 OK, DIM REFERENCES ¼-20 HOLES FOR SHIM ATTACH
 Inspection Test #: 1100 rejected: : 80.49: 80.469
 OK, DIM REFERENCES ¼-20 HOLES FOR SHIM ATTACH
 Inspection Test #: 1110 rejected: : 87.87 ~ .010: 87.838
 OK, DIM REFERENCES ¼-20 HOLES FOR SHIM ATTACH
 Inspection Test #: 1120 rejected: : 89.64 ~ .010: 89.584
 OK, DIM REFERENCES ¼-20 HOLES FOR SHIM ATTACH
 Inspection Test #: 1150 rejected: : 11.48 ~ .010: 11.463
 OK, DIM REFERENCES ¼-20 HOLES FOR SHIM ATTACH
 Inspection Test #: 1290 rejected: : 88.39 ~ .010: 88.371
 OK, DIM REFERENCES ¼-20 HOLES FOR SHIM ATTACH
 Inspection Test #: 1320 rejected: : 28.71 ~ .010: 28.721
 OK, DIM REFERENCES ¼-20 HOLES FOR SHIM ATTACH
 Inspection Test #: 1340 rejected: : 22.117 ~ .005: 22.109
 OK, DIM REFERENCES ¼-20 HOLES FOR SHIM ATTACH
 Inspection Test #: 1350 rejected: : 38.14 ~ .010: 38.152
 OK, DIM REFERENCES ¼-20 HOLES FOR SHIM ATTACH
 Inspection Test #: 1380 rejected: : 7.53 ~ .010: 7.555
 OK, DIM REFERENCES ¼-20 HOLES FOR SHIM ATTACH
 Inspection Test #: 1390 rejected: : 4.91 ~ .010: 4.879
 OK, DIM REFERENCES ¼-20 HOLES FOR SHIM ATTACH

MTM is requested to add Visual Manufacturing references on data lists.

Customer: ENERGY INDUSTRIES OF OHIO

Contact: NANCY HORTON
E-Mail: NKHFlowen@aol.com

Telephone: 216-496-2314
Fax: 216-328-2001

Part: SE141-116 / MODULAR COIL WINDING FORM TYPE
Drawing ID: SE141-116 Revision: 7

Customer P.O.: S005242-F/Ln:2
Serial No./Qty: C2

Reported By: MIKE GRIFFITH
E-Mail: mGriffith@MajorTool.com

Telephone: 317-636-6433
Fax: 317-634-9420

Problem: THERE ARE NOT ENOUGH DATA POINTS IN THE POINT CLOUD SURFACES TO MATCH THE REQUIREMENT OF 4" X 4" ON AS-CAST SURFACES.

Proposed Disposition:

CUSTOMER TO ADVISE THE ACCEPTABILITY OF NOT HAVING ENOUGH DATA POINTS.

Number of additional pages: _____

Customer Disposition: Use As Is Rework Repair Scrap Replace

This data will be accepted for C2. PPPL will take additional measurements upon receipt to fill in the gaps in the data provided. However, EIO is requested to take corrective actions to assure that the metrology data on all future winding forms comply with the specified requirements.

Tech. Rep. Approval:

**Phil
Heitzenroeder**

Digitally signed by Phil Heitzenroeder
DN: CN = Phil Heitzenroeder, C = US,
O = PPPL, OU = Mech. Eng. Division
Reason: I agree to 'specified' portions
of this document
Date: 2005.12.13 13:04:15 -05'00'

RLM Approval:

**Brad
Nelson**

Digitally signed by Brad Nelson
DN: cn=Brad Nelson, c=US,
o=ORNL, ou=FED,
email=nelsonbe@ornl.gov
Date: 2005.12.13 13:30:17
-05'00'

Major Tool Implemented By: *[Signature]*

Title: CFT ENGINEER

Date: 12/22/05

n:\vntmapps\Wtmnnc14.qrp

Customer: ENERGY INDUSTRIES OF OHIO

Contact: NANCY HORTON
E-Mail: NKHFlowen@aol.com

Telephone: 216-496-2314
Fax: 216-328-2001

Part: SE141-116 / MODULAR COIL WINDING FORM TYPE

Customer P.O.: S005242-F/Ln:2
Serial No./Qty: C2

Drawing ID: Revision:

Reported By: MIKE GRIFFITH
E-Mail: mGriffith@MajorTool.com

Telephone: 317-636-6433
Fax: 317-634-9420

Problem: NC18022 was dispositioned by PPPL to perform a weld repair. Weld repairs require LPI (CSPEC par 3.1.1.6) & RT (CSPEC par 3.1.1.7) inspection per 3.2.3.2.2, as well as magnetic permeability checking per 3.1.1.5. LPI and Mag Permeability were performed during the post machining inspection operations. The RT inspection of this specific repair was not completed.

Proposed Disposition:

Recommend to accept as is.

Number of additional pages: _____

Customer Disposition: Use As Is Rework Repair Scrap Replace

this repair is in a low stress area.

Technical Contact Approval: *P. Reitzner*

Title: *Tech. Rep.*

Date: *12/14/05*

Buyer Approval: _____

Title: _____

Date: _____

Major Tool Implemented By: *[Signature]*

Title: *CFT ENGINEER*

Date: *12/14/05*

Princeton University Plasma Physics Laboratory
James Forrestal Campus
P.O. Box CN17
Princeton, N.J. 08543

21 December 2005

Ms. Nancy Horton
Energy Industries of Ohio
6100 Oak Tree Boulevard, Suite 200
Independence, Ohio 44131

SUBJECT: Dispositioned Request for Deviation (RFD) 14-011
 Subcontract S005242-F

Dear Ms. Horton:

Attached for appropriate action is NCSX dispositioned Request for Deviation 14-011, Subject: Change in Magnetic Permeability Requirements, initiated by Kevin Bowling on 23 November 2005.

Regards,

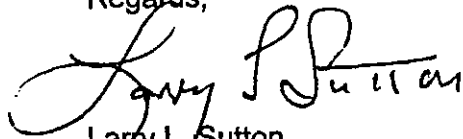

Larry L. Sutton
Senior Subcontract Administrator

Attachment: As stated

NCSX RFD <i>Part III</i>	Number: 14-011	RFD Description: Change in Magnetic Permeability Requirements
RLM: Brad Nelson		Organization: ORNL
Impact on Interfaces with Other WBS Elements/Items: (If none, so state): NONE, WBS 14 only		
<p>RLM Recommendation:</p> <p><input checked="" type="checkbox"/> Approve <input type="checkbox"/> Do Not Approve</p> <p>Additional remarks:</p> <p>No impact on quality will result from using this material. Analysis shows that if material used at all six locations on each Type C casting, the resultant field errors will be negligible. It is anticipated that analysis of Type A and Type B castings will show similar results.</p> <p>Does this Change Impact Material Already Procured or Parts/Assemblies Already Assembled/Manufactured using this Material: <input checked="" type="checkbox"/> Yes <input type="checkbox"/> No</p> <p>If "Yes", what is the recommended disposition of this material/part/assembly?</p> <p>Accept as is for the Type C castings. Analysis at PPPL has confirmed that the effects of using this 1.03μ material will have a negligible impact and that if similar results for Type A and Type B castings result, the effects will likewise be negligible.</p>		
RLM Signature: <u>Brad Nelson</u>		<small>Digitally signed by Brad Nelson DN: cn=Brad Nelson, ou=US, o=ORNL, ou=FED, email=brnel@ornl.gov Date: 2005.12.20 14:27:35 -0500</small>
<p>Project Disposition:</p> <p><input type="checkbox"/> Approved. No ECP required. _____ NCSX Systems Engineering Support Manager</p> <p><input checked="" type="checkbox"/> Approved. An ECP will be assigned when Section 3.1.1.5.2 is revised accordingly (by end of January).</p> <p><input type="checkbox"/> Not Approved. Reason(s) for disapproval:</p> <p style="text-align: right;">Bob Simmons <small>Digitally signed by Bob Simmons DN: CN = Bob Simmons, C = US Reason: I am approving this document Date: 2005.12.20 12:43:29 -0500</small></p>		

<i>NCSX RFD</i> <i>Part I</i>	Number: 14-011	RFD Description: Change in Magnetic Permeability Requirements
Initiator: Kevin Bowling	Organization: Major Tool	
List of Impacted Documents: (<i>Specification, MIT/QA Plan, SOW, drawing, etc.</i>) NCSX-CSPEC-141-3, MTM MIT/QA Plan, SE141-103		
Cost Impact: (<i>If none, so state</i>): NONE		
Schedule Impact: (<i>If none, so state</i>): NONE		
Quality Impact: (<i>If none, so state</i>)): Unknown to MTM.		
State Requirement Deviation is Requested For: (<i>Specification, MIT/QA Plan, SOW, drawing, etc.</i>): MTM requests permission to change the CSPEC section 3.1.1.5.2 magnetic permeability requirements for all remaining MCWF bearing plates from 1.02 μ to 1.03 μ .		
Full Description of the Deviation Requested: (<i>Use continuation pages, e-mails, letter, sketches, etc. as needed and include amplifying information as appropriate to support deviation request</i>): MTM ordered the material for several C castings, but receipt tests revealed that the 316ST annealed hot rolled bar from supplier did not meet the CSPEC Section 3.1.1.5.2 requirements. The entire material lot received from the supplier did meet the suggested permeability requirements of this RFD. It is anticipated that follow-on orders will made to the same supplier and that similar magnetic permeability results can be expected.		
Attachments: MTM-RFD-003 dated November 23, 2005		
Initiator Signature: <u>Kevin Bowling</u> Date: <u>November 23, 2005</u>		

Request for Deviation

MCWF Type A, B, and C

Serial Number: All remaining MCWF winding form parts

Number: MTM-RFD-003

RFD Description:

1. MTM requests permission to change the magnetic permeability requirement for the Bearing Plate details to be less than or equal to 1.03 μ .

Initiator: Kevin Bowling

Organization: Major Tool and Machine, Inc.

List of Impacted Documents:

NCSX-CSPEC-141-03, MTM MIT/QA Plan, SE141-103.

Quality Impact: Unknown to MTM. 316SST annealed hot rolled bar from supplier meets the requirements listed in the RFD description above.

Customer Approval

Signature: _____ **Date:** _____

Kevin Bowling
23-Nov-2005



Page 1 of 1

EASTWOOD MANUFACTURING
CERTIFICATION OF COMPLIANCE

CUSTOMER : MAJOR TOOL AND MACHINE
ORDER # : P05-01160

DATE : 5-16-05
OUR NUMBER 32984

WE CERTIFY THAT THE MATERIALS SUPPLIED ON YOUR ORDER
LISTED ABOVE COMPLIES WITH THE REQUIREMENTS OF YOUR ORDER
AND OF THE SPECIFICATIONS LISTED BELOW

DESCRIPTION .

Lot No., 32984-1	28 PIECES	Part . DS141-036 ASTM A286 Silver plated Per AMS2410	Heat No., 8969595	1 7/16 Round, machined to size Heat Treat. 36891 Silver plate, IMF 00132583 Post plate bake. SEI 37905 Tensile test. WH 05-0420-01
---------------------	-----------	--	-------------------	--

TENSILE KSI	YIELD KSI	ELONGATION	REDUCTION	HARDNESS
150	120	14	35	
PASS	PASS	PASS	PASS	PASS

DALE STARK
EASTWOOD MANUFACTURING

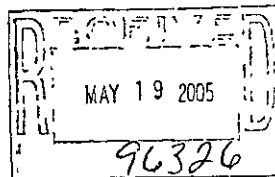

1-4
B-1

NTM
09 5/19/05

studs



401 ROSE AVE S E
MASSILLON, OH 44646

FAX 330-837-7017

CERTIFICATE OF TESTS

REPUBLIC ENGINEERED PRODUCTS

JANUARY 26, 2005

PAGE: 1 OF 3

PURCHASE ORDER: 42904-3
PART NUMBER : SN 47670
ORDER NUMBER: 12-52585-06 821
HEAT : 8969595

PURCHASE ORDER DATE: 05/24/04
ACCOUNT NUMBER : 27759001
SCHEDULE : 58828-

CHARGE ADDRESS

SHIP TO

5456068

FRY STEEL COMPANY
BUNNIE ISAKA
13325 MOLETTE ST
SANTA FE SPRINGS CA 90670

FRY STEEL COMPANY
BUNNIE ISAKA
C/O CMT
4201 W 36TH ST
CHICAGO IL 60623

MATERIAL DESCRIPTION
COLD FINISHED STEEL BARS ALLOY DOUGLAS SPEC DMS-1555H GRADE B DTD 07/02/91 EXC
MARK & PARA 3.4 OIL TEMP & 3.5 BOEING SPEC BMS 7-280 ASTM A 331-95 ASTM A
108-03 LEVEL 1 MIL S 5000E COND E-4 EXC MARK AMS 6415R EXC BHN AMS 6409B AMS
2310E AMS 2301J AMS 2304A AMS 6484B AMS -S- 5000 ISS 3/99 COND E-4 EXC MARK &
PARA 4.3 EF-AISI-E-4340 AIRCRAFT Q DEL TRANSV MECH PROP COLD DRAWN NOR
M & SUBCRITICAL ANN BEFORE CD REST CHEM

SIZE: RDS 1.4375 X 11 /13FT

LADLE CHEMISTRY %

C	MN	P	S	SI	CU	NI	CR	MO	AL
0.42	00.75	.007	.002	0.22	0.10	01.70	00.84	0.21	00.028
0.005	.0064	0.002	.007						

AUSTENITIC GRAIN SIZE

AUST GRAIN SZ 7.

SEMI-FINISH RESULTS

DEVELOPED TENS TRANS
NORMALIZE
DEG F
1650.

ASTM E8
AUSTENITIZE
DEG F
1550.

ASTM A370
QUENCHANT
OIL

TEMPER 1
DEG F
900.

TEMP 1 TIME
HOURS
2.0

PC	CH	HTH	TENSILE PSI
10102	10102	10102	185010.
10302	10302	10302	180280.
10503	10503	10503	185540.
30102	30102	30102	180570.
30302	30302	30302	193790.
30504	30504	30504	185240.

REDUCTION AREA PERCENT
45.5
45.5
45.7
43.4
43.0
46.3

DEVELOPED TENS TENSILE
NORMALIZE
DEG F
1650.

ASTM E8
AUSTENITIZE
DEG F
1500.

ASTM A370
QUENCHANT
OIL

TEMPER 1
DEG F
475.

TEMPER 2/SR
DEG F
475.

TEMP 1 TIME
HOURS
2.0

TEMP 2 TIME
HOURS
2.0

PC	CH	HTH	TENSILE PSI
10102	10102	10102	222320.
10302	10302	10302	224250.
10503	10503	10503	222170.
30102	30102	30102	221840.
30302	30302	30302	221260.
30504	30504	30504	221050.

YIELD (.2%) PSI
223800.
222910.
225100.
218860.
222160.
225230.

REDUCTION AREA PERCENT	ELONGATION PERCENT
47.0	10.4
44.6	11.4
44.6	14.3
43.8	11.4
49.3	11.4
48.2	12.9

11111

32984

AMAN BHATIA
GEN MGR COLD FINISH OPERATIONS

Aman Bhatia

MTM
DS
5/19/05



401 ROSE AVE S E
MASSILLON, OH 44646

FAX 330-837-7017

CERTIFICATE OF TESTS REPUBLIC ENGINEERED PRODUCTS

JANUARY 26, 2005
PAGE: 2 OF 3

PURCHASE ORDER: 42904-3
PART NUMBER: 84 47670
ORDER NUMBER: 12-52585-06 821
HEAT: 8969595
PURCHASE ORDER DATE: 05/24/04
ACCOUNT NUMBER: 27759001
SCHEDULE: 58828-

SEMI-FINISH RESULTS (CONTINUED)

DEVELOPED TRANS TENSILE
NORMALIZE
DEG F
1650.
TEMPER 2/SR
DEG F
475.
ASTM E8
AUSTENITIZE
DEG F
1500.
TEMP 1 TIME
HOURS
2.0
ASTM A370
QUENCHANT
OIL
TEMPER 1
DEG F
475.
TEMP 2 TIME
HOURS
12.0

Table with columns: TENSILE (PSI), YIELD (.2%), REDUCTION AREA (PERCENT), ELONGATION (PERCENT). Rows include various part numbers like 10102, 10302, 10503, etc.

JOMINY STD SAE J406 ASTM A255
58 2 3 4 5 6 7 8 9 10 11 12 13 14 15 16 18 20 22 24 26 28 30 32
58 58 57 57 57 57 56 56 56 56 56 55 55 55 55 55 54 53 52 51 51 50 49 49

MACROETCH SRC SURFACE 1. RANDOM .1. CENTER 1.
ASTM E361 MIL STD 430

MAG PARTICLE 2301 AMS 2301
AVG AVG FREQ 0.00 AVG SEV 0.00
MAG PARTICLE 2304 AMS 2304
AVG AVG FREQ 0.00 AVG SEV 0.00

FINISH SIZE RESULTS SCHEDULE: 58828

DECARBURIZATION TOTAL DEPTH INCHES
PCE 01 .015
SAE J419 ASTM E1077
HBW SURFACE (LAB) ASTM E10 ASTM A370
PCE 01 HBW 217.
PCE 02 HBW 217.
PCE 03 HBW 217.
PCE 04 HBW 217.
PCE 05 HBW 221.

MATERIAL SOURCES
RED. RATIO
TO 1
73.6

TENSILE HT TRTD NORMALIZE
DEG F
PCE 01 1625.
ASTM E8 ASTM A370

NOTES
THE MATERIAL WAS NOT EXPOSED TO MERCURY OR ANY METAL ALLOY THAT IS LIQUID AT AMBIENT TEMPERATURE DURING PROCESSING OR WHILE IN OUR POSSESSION.

CHEMICAL ANALYSIS CONFORMS TO APPLICABLE SPECS: ASTM E415, ASTM E1019, AND ASTM E1085.

AMAN BHATIA
GEN MGR COLD FINISH OPERATIONS
Amn Bhatia

MTM 05 5/19/05

32084



401 ROSE AVE S E
MASSILLON, OH 44646

FAX 330-837-7017

CERTIFICATE OF TESTS REPUBLIC ENGINEERED PRODUCTS

JANUARY 26, 2005
PAGE: 3 OF 3

PURCHASE ORDER: 42904-3	PURCHASE ORDER DATE: 05/24/04
PART NUMBER : SN 47670	ACCOUNT NUMBER : 27759001
ORDER NUMBER : 12-52585-06 821	SCHEDULE : 58828-
HEAT : 8969595	

NOTES (CONTINUED)
NO WELDING OR WELD REPAIR WAS PERFORMED ON THIS MATERIAL.

RECORDING OF FALSE, PICTITIOUS OR FRAUDULENT STATEMENT OR ENTRIES ON THIS DOCUMENT MAY BE PUNISHED AS A FELONY UNDER FED STATUES TITLE 18 CHAPTER 47.

I HEREBY CERTIFY THAT THE MATERIAL LISTED HEREIN HAS BEEN INSPECTED AND TESTED IN ACCORDANCE WITH THE METHODS PRESCRIBED IN THE GOVERNING SPECIFICATIONS AND BASED UPON THE RESULTS OF SUCH INSPECTION AND TESTING HAS BEEN APPROVED FOR CONFORMANCE TO THE SPECIFICATIONS.

CERTIFICATE OF TESTS SHALL NOT BE REPRODUCED EXCEPT IN FULL.

WHEN EVALUATED, MACRO ETCHES WERE VISUALLY RATED ON SAMPLES ETCHED USING HYDROCHLORIC ACID AT A TEMPERATURE 170 DEGREES(F) (+/- 10 DEGREES F)

ALL TESTING HAS BEEN PERFORMED USING THE CURRENT REVISION OF THE TESTING SPECIFICATIONS.

MFG IN THE U.S.A.

ALISON J. BLONDHEIM
NOTARY PUBLIC, STATE OF OHIO
MY COMMISSION EXPIRES MARCH 10, 2009

FAX SHIP TO	1 COPY	ATTENTION BUNNIE ISAKA
MAIL SOLD TO	1 COPY	ATTENTION BUNNIE ISAKA
FILE	1 COPY	
WITH SHIPMENT	1 COPY	

END OF DATA
562-802-7481

SHIPPING AREA:

32984

PRY STEEL CO. CERTIFIES THAT THIS IS
A TRUE COPY OF THE ORIGINAL MILL TEST
REPORT NOW ON FILE.
RECEIVED AND INSPECTED

FEB 14 2005

Bunnie Isaka
BUNNIE ISAKA, CC MEMBER

AMAN BHATIA
GEN MGR COLD FINISH OPERATIONS
Aman Bhatia

MM
09 5/19/05

Tensile Test Report

Company: Eastwood Mfg. Date: 4/22/2005
 Lab Report #: 05-0420-01
 Attention: Dele Stark P.O. #: 32984
 Identification: AISI 4340
 Procedure: 1-3/8" O.D.
 Process: _____
 Filler: Heat#8969585
 Qualification: _____
 Welder: _____

32984

32984

TENSILE TEST

Lab ID	Dimensions	Area	Yield Lbs	Ultimate Load Lbs	Yield P.S.I.	Tensile P.S.I.
C	.504 round	.1995	31,880	34,700	159,700	174,000

Elongation	Reduction of Area	Fracture	Comments
18.2%	52.3%	Ductile	

Tests performed in accordance with ASTM A370, E8, and WH Laboratories, LLC Quality Assurance Manual.
 2% Offset Yield - Gage Length 2.000" for .500", and 1.000" for .350" tensile per ASTM A370.
 Test specimens retained for one (1) week maximum; unused material is retained for one (1) month.

Approved by: Robert French
 Robert French

MTM 09 5/19/05

From: Eastwood Manufacturing 281-447-0098 To: MAJOR TOOL & MACHINE

Date: 5/17/2005 Time: 1:48:22 PM

Page 7 of 22

MAY-13-2005 12:55 FROM:

TO:2814470098

P:2/2

SEI HEAT TREAT

PO BOX 16339 HOUSTON, TX 77222
PHONE (713) 694-3882 FAX (713) 694-0891

CUSTOMER: EASTWOOD MANUFACTURING	CERTIFICATION DATE: MAY 11, 2005
CERTIFICATION/SO NUMBER: 37905	CUSTOMER ORDER NUMBER: 32984

MATERIAL: 4340	NUMBER OF PIECES: 28
DESCRIPTION: 1-3/8" X 6" STUDS SILVER PLATED	PART NUMBER(S): N/A
SPECIFICATION NUMBER: EASTWOOD MANUFACTURING	REFERENCE: N/A

32984

HEAT TREAT PROCESS	TIME AT HEAT	COOLANT
Bake	950'	45 min AIR

32984

HARDNESS TEST:	NUMBER OF PIECES TESTED:

WE HEREBY CERTIFY THAT THE SERVICE FURNISHED ON THE ABOVE PURCHASE ORDER IS PROVIDED IN ACCORDANCE WITH OUR QUALITY CONTROL MANUAL, REVISION B, DATED JANUARY 21, 2001	QUALITY CONTROL: <i>Lamin</i>
---	---

Copyright © 2000 SEI Heat Treat

MTM 09 5/19/05

INDUSTRIAL METAL FINISHING

CERTIFICATE OF COMPLIANCE

TO: EASTWOOD MFG. 5/86
P.O. BOX 41447
HOUSTON, TX 77241

THIS IS TO CERTIFY THAT THE METAL FINISHING SERVICE RENDERED ON ITEM(S)

126 EA. - 1.375 X 9 DE STUDS
252 EA. - 2.75 OD WASHERS
252 EA. - 1.375 12PT NUTS

ON PURCHASE ORDER 32984 LISTED ON OUR INVOICE #00132583

MEETS OR EXCEEDS THE REQUIREMENTS OF SPECIFICATION NUMBER

CERT: SILVER PLATE PER ANS 2410
NO BAKE REQUIRED

QUALITY PROGRAM DATED: 05/01/93 REVISION: 1 DATED: 04/01/94

Tair McPherson
NAME:

QC Manager 5/10/05
TITLE DATE

32984

MTM 05
5/19/05

EASTWOOD MANUFACTURING
CERTIFICATION OF COMPLIANCE

CUSTOMER : MAJOR TOOL AND MACHINE
ORDER # : P05-01168

DATE : 5-16-05
OUR NUMBER 32982

WE CERTIFY THAT THE MATERIALS SUPPLIED ON YOUR ORDER
LISTED ABOVE COMPLIES WITH THE REQUIREMENTS OF YOUR ORDER
AND OF THE SPECIFICATIONS LISTED BELOW

DESCRIPTION :

Lot No.:	Part :	Heat No.:	1 5/8 Round, forged and machined to size
32982-1	DS141-060	8977349	Heat Treat: 36891
56 PIECES	ASTM A286		Silver plate: IMF 00132583
	Silver plated		Post plate bake: none
	Per AMS2410		Tensile test: WH 05-0426-20

TENSILE KSI	YIELD KSI	ELONGATION	REDUCTION	HARDNESS
150	120	14	35	
PASS	PASS	PASS	PASS	PASS

DALE STARK
EASTWOOD MANUFACTURING

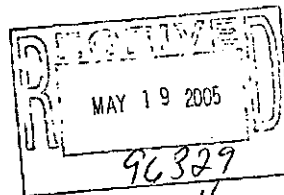

1-4
B.7

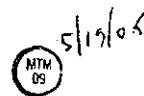

Washers nuts



GARY COLD FINISHED BAR PLANTS
PHONE: 219-886-8129 FAX: 219-886-8123

CERTIFICATE OF TESTS REPUBLIC ENGINEERED PRODUCTS

SEPTEMBER 27, 2004
PAGE: 1 OF 2

PURCHASE ORDER: 4271475
PART NUMBER : S# 31250
ORDER NUMBER : 12-31689-04 823
HEAT : 8977349

PURCHASE ORDER DATE: 03/11/04
ACCOUNT NUMBER : 27759001
SCHEDULE : 54199-

CHARGE ADDRESS

SHIP TO

6/11/05

FRY STEEL COMPANY
BUNNIE ISAKA
13325 MOLETTE ST
SANTA FE SPRINGS CA 90670

FRY STEEL COMPANY
BUNNIE ISAKA
C/O CMI
4201 W 36TH ST
CHICAGO IL 60623

MATERIAL DESCRIPTION

COLD FINISHED STEEL BARS ALLOY ASTM A 331-95 ASTM A 108-03 LEVEL 2 MIL 8 5626C
E1000 1 COND C-4 EXC MARK & PARA 4.3.1 & 4.12.1 WAIVED AMS 6382M AMS 2304A AMS
6349C EXC THERMAL TREATMENT AMS 2301J AMS - S - 5626 ISS 12/98 EXC PARA 4.3.1 &
4.12.1 EF-AISI-4140 AIRCRAFT Q TURNED & POLISHED ANN BEFORE TURN

SIZE: RDS 1.6250 X 11.713FT

LADLE CHEMISTRY

C	MN	P	S	SI	CU	NI	CR	MO	AL
0.42	00.90	.011	.020	0.24	0.18	00.16	00.97	0.21	00.027
V	N	CB	SN						
0.004	0.0067	0.002	0.009						

SEMI-FINISH RESULTS

AUSTENITIC GRAIN SIZE
AUST GRXIN SZ 7

JOMINY STD										SAE J406										ASTM A255																									
1	2	3	4	5	6	7	8	9	10	11	12	13	14	15	16	18	20	22	24	26	28	30	32	56	57	58	59	60	61	62	63	64	65	66	67	68	69	70	71	72	73	74	75		
58	57	57	56	56	56	55	55	55	53	52	50	48	47	45	44	43	40	39	38	38	38	38	37	38	37																				

MACROETCH SRC SURFACE 1. RANDOM 1. CENTER 1. ASTM E381 MIL STD 430

MAG PARTICLE 2301 AMS 2301 AVG FREQ 0.00 AVG SEV 0.00

MAG PARTICLE 2304 AMS 2304 AVG FREQ 0.00 AVG SEV 0.00

FINISH SIZE RESULTS

SCHEDULE: 54199
ASTM E10 ASTM A370

BHN	HT	TRTD (LAB)
PCE 01		SURFACE 187
PCE 02		SURFACE 187
PCE 03		SURFACE 187
PCE 04		SURFACE 187
PCE 05		SURFACE 187

MATERIAL SOURCES
RED. RATIO
TO 1
58.2

5/15/05

NOTES

DECARB NIL

THE MATERIAL WAS NOT EXPOSED TO MERCURY OR ANY METAL ALLOY THAT IS LIQUID AT AMBIENT TEMPERATURE DURING PROCESSING OR WHILE IN OUR POSSESSION.

CHEMICAL ANALYSIS CONFORMS TO APPLICABLE SPECS:
ASTM E 327 ASTM E 1086 ASTM E 415 ASTM E 1019 ASTM E 1085 ASTM E572.

NO WELDING OR WELD REPAIR WAS PERFORMED ON THIS MATERIAL

AMAN BHATIA
GEN MGR COLD FINISH OPERATIONS

Aman Bhatia





GARY COLD FINISHED BAR PLANTS
PHONE: 319-886-8129 FAX: 219-886-8123

CERTIFICATE OF TESTS REPUBLIC ENGINEERED PRODUCTS

SEPTEMBER 27, 2004
PAGE: 2 OF 2

PURCHASE ORDER: 42714-5
PART NUMBER : 54-51250
ORDER NUMBER: 12-51689-04 823
HEAT : 8977349

PURCHASE ORDER DATE: 03/11/04
ACCOUNT NUMBER : 27759001
SCHEDULE : 54199-

NOTES (CONTINUED)

I HEREBY CERTIFY THAT THE MATERIAL HEREIN HAS BEEN INSPECTED AND TESTED IN ACCORDANCE WITH THE METHODS PRESCRIBED IN THE GOVERNING SPECIFICATIONS AND BASED UPON THE INSPECTION AND TESTING HAS BEEN APPROVED FOR CONFORMANCE TO THE SPECIFICATIONS

CERTIFICATE OF TESTS SHALL NOT BE REPRODUCED EXCEPT IN FULL.

ALL TESTING HAS BEEN PERFORMED USING THE CURRENT REVISION OF THE TESTING SPECIFICATION.

MFG IN THE U.S.A.

EVELYN GREENE
NOTARY PUBLIC, STATE OF INDIANA
MY COMMISSION EXPIRES OCTOBER 10, 2009

END OF DATA CC END OF DATA
FAX BY FAX PC 1 COPY ATTENTION BUNNIE ISAKA 562-802-7481
MAIL SOLD TO 1 COPY ATTENTION BUNNIE ISAKA
FILE 1 COPY
WITH SHIPMENT 1 COPY PRINTED AT SHIPPING AREA

REPUBLIC CO CERTIFIES THAT THIS IS A TRUE COPY OF THE ORIGINAL MILL TEST REPORT NOW ON FILE

OCT 05 2004

Bunnie Isaka
BUNNIE ISAKA - Q.C. MANAGER

AMAN BHATIA
GEN MGR. COLD FINISH OPERATIONS
Aman Bhatia

5/19/05
NTM
09

04/27/2005 07:39

7138959986

WM LABORATORIES

PAGE 02

Tensile Test Report

Company: Eastwood Mfg. Date: 4/27/2005
 Attention: Dale Stark Lab Report #: 06-0428-20
 Identification: AISI 4140 P.O. #: 32882
 Procedure: _____ 1-5/8" Diameter Bar
 Process: _____
 Filler: _____
 Qualification: _____
 Welder: _____

TENSILE TEST

Lab ID	Dimensions	Area	Yield Lbs	Ultimate Load Lbs	Yield P.S.I.	Tensile P.S.I.
E	.252 round	.0499	7,140	8,000	143,100	180,400

Elongation	Reduction of Area	Fracture	Comments
18.8%	61.2%	Ductile	

Tests performed in accordance with ASTM A370, E8, and WM Laboratories, LLC Quality Assurance Manual.
 2% Offset Yield - Gage Length 2.000" for .500", and 1.400" for .360" rods per ASTM A370.
 Test specimens retained for one (1) week maximum; unused material is retained for one (1) month.

Approved by: Robert French
 Robert French

5/19/05

INDUSTRIAL METAL FINISHING

CERTIFICATE OF COMPLIANCE

TO: EASTWOOD MFG. 5/86
P.O. BOX 41447
HOUSTON, TX 77241

THIS IS TO CERTIFY THAT THE METAL FINISHING SERVICE RENDERED ON ITEM(S)

126 EA. - 1.375 X 9 DE STUDS
252 EA. - 2.75 OD WASHERS
252 EA. - 1.375 12PT NUTS

ON PURCHASE ORDER 12984 LISTED ON OUR INVOICE #00132583

MEETS OR EXCEEDS THE REQUIREMENTS OF SPECIFICATION NUMBER

CERT: SILVER PLATE PER AMS 2410
NO BAKE REQUIRED

QUALITY PROGRAM DATED: 05/01/93 REVISION: 1 DATED: 04/01/94

Tai McPhilly
NAME:

QC Manager *5/10/05*
TITLE DATE

12984

5/19/05
MTH
05

03/04/05 13:38 FAX 830 834 9427
 MAJOR TOOL & MACHINE INC
 1458 E 19TH ST
 INDIANAPOLIS IN 46218

McMASTER CARR SUPPLY #3
YOUR PURCHASE ORDER NUMBER
 P05-01260

McMASTER-CARR
 680 COUNTY LINE ROAD
 ELMHURST IL 60126-2061
 IF THERE ARE ANY QUESTIONS ABOUT THIS SHIPMENT CONTACT OUR SALES DEPARTMENT (630)833-0300

002
 PAGE 1
 MCM NUMBER 6148181-01

Warehouse Location	McMaster Carr Part Number	Fit Quantity	Item Description	Your Line	Your Order	This Shipment
PACKING LIST EXTRA	74765 A86	1 EA	LOCTITE PRISM SUPER GLUE TOUGHENED, NUMBER 411, 1-POUND BOTTLE, CLEAR 1	1	1 EA	1
	74765 A86	1 EA	LOCTITE PRISM SUPER GLUE TOUGHENED, NUMBER 411, 1-POUND BOTTLE, CLEAR 1	2	1 EA	1
		XXXXXX	Information about the rest of your order		XXXXXX	
	74765 A86		LOCTITE PRISM SUPER GLUE Balance of 1 EA expected to ship by 3/7/2005	3	1 EA	
	74765 A86		LOCTITE PRISM SUPER GLUE Balance of 1 EA expected to ship by 3/7/2005	4	1 EA	
	74765 A86		LOCTITE PRISM SUPER GLUE Balance of 1 EA expected to ship by 3/7/2005	5	1 EA	
	74765 A86		LOCTITE PRISM SUPER GLUE Balance of 1 EA expected to ship by 3/7/2005	6	1 EA	

REFER TO: 6148181-01
 MAJOR TOOL & MACHINE INC

Certificate of Compliance
 This is to certify that according to our records, the material furnished on this purchase order was supplied in compliance to the description listed, and as illustrated in our catalog.

Nancy Lancaster
 Quality Control

PACKER	NUMBER OF CARTONS	FILLER

LNS: 2

TAG CCP

CYCLE

MCM NO. 6148181-01 04

PURCHASE ORDER
 P05-01260

FROM:
 McMASTER-CARR
 680 COUNTY LINE ROAD
 ELMHURST IL 60126-2061 USA

SHIP TO:
 MAJOR TOOL & MACHINE INC
 1458 E 19TH ST
 INDIANAPOLIS IN 46218

CCP

MAR - 4 2005
 93966
 112 B-1

3/4/05

2002

T3CE0



Shipping List 072435
Customer No 101193
Sales Order Shipper

Sold to : STANDARD GRINDING & MFG CO
3721 W. CHASE AVENUE
SKOKIE, IL 60076
United States

Ship to : STANDARD GRINDING & MFG CO
3721 W. CHASE AVENUE
SKOKIE, IL 60076
United States

Ship Date	Customer PO	Sales Order	# of Boxes	Weight	Ship VIA	Bill of Lading	F O B
05/17/2005	60624	085171-00	1	0	YELLOW	072435	DE
Item	Part / Description / Details				Order Quantity	Ship Qty	
000001	39GTCNT73125NMWLF U/M SHT SO Item 4				1.00000		
	G-11-CR 48" untrimmed X 36" untrimmed Thickness: 3.125" +/- .110" PLEASE NOTE THAT THERE IS NO NEMA STANDARD FOR G-11 CR SHEET SPAULDING C OF C TO G-11 CR SHEET NO TESTING REQUIRED AT TIME OF ORDER <i>Sheet less 3.500 Tc</i>					1.00000	

CERTIFICATE of CONFORMANCE

WE HEREBY CERTIFY THAT THE MATERIAL SUPPLIED ON THIS ORDER WAS MADE IN ACCORDANCE WITH THE STANDARDS AND PROCESSES ESTABLISHED BY SPAULDING COMPOSITES COMPANY FOR THE REQUIREMENTS OF MATERIAL DESCRIBED ABOVE.

LOT# _____ DOM. _____
 Authorized By: Mark L. Candillo Date: 05/17/2005

Customer Copy

Page # 1

Form: SCSHIP Rev: 8/99

000/200

ATLAS FIBRE CO.

8647 674 1723

05/28/05 13:00



Spaulding
COMPOSITES

55 Nadeau Drive
Rochester, NH 03867
Ph: (603) 332-0555 Fax: (603) 332-5357
www.spauldingcom.com

Shipping List 072434

Customer No 101193
Sales Order Shipper

Sold to : STANDARD GRINDING & MFG CO
3721 W. CHASE AVENUE
SKOKIE, IL 60076
United States

Ship to : STANDARD GRINDING & MFG CO
3721 W. CHASE AVENUE
SKOKIE, IL 60076
United States

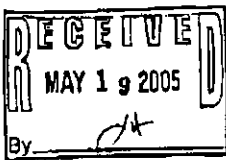
Ship Date	Customer PO	Sales Order	# of Boxes	Weight	Ship VIA	Bill of Lading	F O B
05/17/2005	60624	063189-00	1	716	YELLOW	072434	DE
Item	Part / Description / Details				Order Quantity	Ship Qty	
000001	39G1CNT71850NMWLF U/M SH7 SO Item 5				1.00000		
	G-11CR 48" *UNTRIMMED X 36" *UNTRIMMED THK: 1.850" +/- .070" PLEASE NOTE THAT THERE IS NO NEMA STANDARD FOR G-11 CR SHEET SPAULDING C OF C TO G-11 CR SHEET NO TESTING REQUIRED AT TIME OF ORDER						1.00000
	 By: <i>[Signature]</i>						

CERTIFICATE of CONFORMANCE

WE HEREBY CERTIFY THAT THE MATERIAL SUPPLIED ON THIS ORDER WAS MADE IN ACCORDANCE WITH THE STANDARDS AND PROCESSES ESTABLISHED BY SPAULDING COMPOSITES COMPANY FOR THE REQUIREMENTS OF MATERIAL DESCRIBED ABOVE.

LOT #

DOM.

Authorized By: Mark Li Caudillo

Date: 05/17/2005

Customer Copy

Page # 1

Form: SCSHIP Rev: 8/99

000/003

ATLAS FIBRE CO.

8447 674 1723

05/28/05 13:00

METRODE PRODUCTS LIMITED
HANWORTH LANE, CHERTSEY

SURREY, UK, KT16 9LL

Tel: +44 (0) 1832 566721

Fax: +44 (0) 1832 565188

Email: info@metrode.com

Website: www.metrode.com

CERTIFIED MATERIAL TEST REPORT

THIS PRODUCT HAS BEEN MANUFACTURED
AND SUPPLIED THROUGH A SYSTEM
APPROVED TO ISO 9001 & 2 OR EQUIVALENT



TEST CERTIFICATE NUMBER

193695

INVOICE TO
EUROWELD LTD
255 ROLLING HILLS ROAD
MOORESVILLE
NC 28117
USA

DESPATCHED TO
EUROWELD LTD
255 ROLLING HILLS ROAD
MOORESVILLE
NC 28117
USA

CUSTOMER ORDER NUMBER	N.05-34
DELIVERY NOTE DOCUMENT NUMBER	DN0105859
QUANTITY (KG)	15.0000
OUR ORDER REFERENCE	SO1787730 / 1
DATE	02/03/05

METRODE WELDING CONSUMABLE	ER316MNNF TIG 2.4mm
FORM	TIG WIRE
BATCH NUMBER	W020132
SPECIFICATION	BS EN 12072:2000 W 20 16 3 Mn L

Chemical Analysis (Weight %)										Type: BS EN 10204: 3.1.B / ASME SFA-5.01: Sch. H	
C	Mn	Si	S	P	Cr	Ni	Mo	N	Cu		
0.015	7.43	0.42	0.008	0.014	19.9	15.4	2.62	0.14	0.20		

--	--	--	--	--	--	--	--	--	--	--	--

Mechanical Tests										Type: BS EN 10204: 2.2 / ASME SFA-5.01: Sch. G	
Tensile Tests						Impact Energies					
Condition	Test Temperature	R _{p0.2} (MPa)	R _m (MPa)	A ₄ (%)	Z (%)	Temperature (°C)	Impact Energy (J)	Lateral Expansion (mm)			
AS-WELDED	ROOM	>400	>600	40	-	-196	70	-			
Metrode Products Limited certifies that the above material conforms to the indicated specifications.		ASME SFA-5.01; Lot classification 54									
This document is produced electronically and is valid without signature.		3/3/05 93911 Linc I B.1									
IMPORTANT: Any liability arising from either reliance on this certificate, or use of our products, is strictly limited and governed by our conditions of business.		Notes: % In includes treatment of Cu unless otherwise specified. % Mn (Cu) includes treatment of Ni unless otherwise specified. Partic is given as FN (Particle number) and measured on standard pad using instrument calibrated against NBS-related secondary standards (see ASTM Std 3-97) unless otherwise specified.									
Barrie Kyjet - Q.A. Manager											

MTH
E9
3/7/05

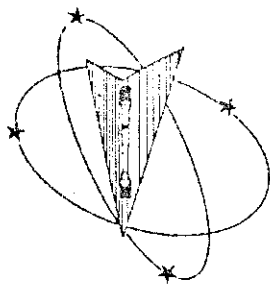

Westmoreland Mechanical Testing & Research, Inc.

P.O. Box 388
Westmoreland Drive
Youngstown, Pa. 15696-0388 U.S.A.
Telephone: 724-537-3131 Fax: 724-537-3151
Website: www.wmtr.com
WMT&R is a technical leader in the material testing industry.

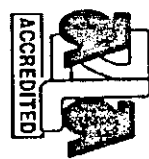

April 22, 2005

Major Tool & Machine Inc.
1458 East 19th Street
Indianapolis, IN 46218

CERTIFICATION

Corrected Date
May 4, 2005

Page IM1 of 1
WMT&R Report No. 5-25008
P.O. No. P05-01764
PQR No. 434
Welder Jason Bever #465

Attention: Josh Mayne

Subject: All processes, performed upon the material as received, were conducted at WMT&R, Inc. in accordance with the WMT&R Quality Assurance Manual, Rev. 9, dated 4/1/2000.
The following tests were performed on this order: IMPACT and TENSILE

IMPACT RESULTS: ASME Section IX and AWS B2.1, ASTM E23-02

No Requirements

MATERIAL: Metalek CF8MNMN MOD

SAMPLE TYPE: Charpy V-Notch

DISPOSITION: Report

Specimen ID	TestLog Number	Sample Size	Temp. °F/°C	Energy ft-lbs	Energy Joules	Mils Lat Exp	AUUR
Weld-1	B65835	Standard	68/20	173	234.6	84	Report
Weld-2	B65836	Standard	68/20	160	216.9	68	Report
Weld-3	B65837	Standard	68/20	157	212.9	81	Report

AUUR: A=ACCEPTABLE, U=UNACCEPTABLE, R=REPORT

KNOWING OR WILLFULLY FAILING OR CONCEALING A MATERIAL FACT ON THIS FORM OR MAKING FALSE STATEMENTS OR FAKING TEST STATISTICS OR REPRESENTATIONS HEREIN COULD CONSTITUTE A FELONY VIOLATING FEDERAL CRIMINAL STATUTES THIS CERTIFICATE OR REPORT SHALL NOT BE REPRODUCED EXCEPT IN FULL, WITHOUT THE WRITTEN APPROVAL OF WMT&R, INC.

Testing Specialists for Aerospace, Automotive, and Material Testing Fields
Locations in Youngstown, PA U.S.A. ~ Tel: (724) 537-3131 and
Barboursville, WV ~ Tel: +44 (0) 1295 261211

Richard G. Parks
Project Manager/Industrial Technology Engineer

5/4/05
May 4, 2005

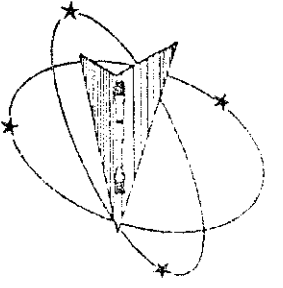

Westmoreland Mechanical Testing & Research, Inc.

P.O. Box 388
 Westmoreland Drive
 Youngstown, Pa. 15696-0388 U.S.A.
 Telephone: 724-537-3131 Fax: 724-537-3151
 Website: www.wmt&r.com
 WMT&R is a technical leader in the material testing industry.

April 20, 2005

Major Tool & Machine Inc.
 1458 East 19th Street
 Indianapolis, IN 46218

CERTIFICATION

Section 1 of 2
 WMT&R Report No. 5-25008
 P.O. No. P05-01764
 POR No. 434
 Welder Jason Beyer #465

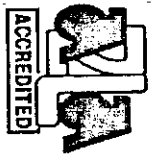

Attention: Josh Mayne
 Subject: All processes, performed upon the material as received, were conducted at WMT&R, Inc. in accordance with the WMT&R Quality Assurance Manual, Rev. 9, dated 4/1/2000.
 The following tests were performed on this order: IMPACT and TENSILE

TENSILE RESULTS: ASME Section IX and AWS B2.1, ASTM E21-03a
SOAK TIME: 5 Minutes
SPEED OF TESTING: 0.0050 in./in./min., 0.0500 in./min./in.
MATERIAL: Metrode ER316Mnnt

DISPOSITION: Report
 AU/R: A=ACCEPTABLE, U=UNACCEPTABLE, R=REPORT

Specimen ID	Testlog Number	Temp. °F/°C	UTS KSI/MPA	0.2% YS KSI/MPA	Elong %	RA %	Modulus MSI/GPA	Ult. Load LBS/NEWTONS	0.2% YLD. LBS/NEWTONS
T1	B65833	-320/-196	191.8/1320	148.7/1030	27	39	28.7/198	2630/11699	2039/9071

DISPOSITION: Report
 AU/R: A=ACCEPTABLE, U=UNACCEPTABLE, R=REPORT

Specimen ID	Testlog Number	Orig. Width (in./mm)	Final Width (in./mm)	Orig. Thick (in./mm)	Final Thick (in./mm)	Orig. Dia. (in./mm)	4D Orig GL (in./mm)	4D Final GL (in./mm)	Orig. Area (Sq. In./Sq. mm)	Failure Location/Type	Machine Number	AU/R
T1	B65833	0.1802/4.57708	0.1437/3.650	0.076/1.933	0.0582/1.478	0.2511/6.378	0.70/17.78	0.89/22.61	0.041838/626.992307	WELD/DUCTILE	M9	R

Roy E. Starr/Matt Wojton
 Technical Services Manager / Tensile Supervisor
 April 20, 2005

Testing Specialists for Aerospace, Automotive, and Material Testing Fields
 Locations in Youngstown, PA U.S.A. ~ Tel: (724) 537-3131 and Danbury, Vt. ~ Tel: +44 (0) 1295 261211

KNOWINGLY OR WILLFULLY FALSIFYING OR CONCEALING MATERIAL FACT ON THIS FORM OR MAKING FALSE, FICTITIOUS OR FRAUDULENT STATEMENTS OR REPRESENTATIONS HEREIN COULD CONSTITUTE A FELONY PUNISHABLE UNDER FEDERAL STATUTES. THIS CERTIFICATE OR REPORT SHALL NOT BE REPRODUCED EXCEPT IN FULL, WITHOUT THE WRITTEN APPROVAL OF WMT&R, INC.

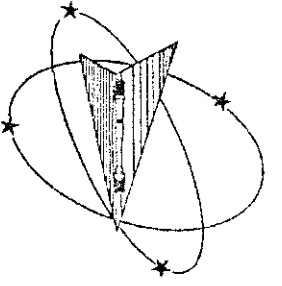

April 20, 2005

Major Tool & Machine Inc.

Westmoreland Mechanical Testing & Research, Inc.

P.O. Box 388

Westmoreland Office

Youngstown, Pa. 15696-0388 U.S.A.

Telephone: 724-537-3151

Fax: 724-537-3151

Website: www.wmtr.com

WMTR is a technical leader in the material testing industry.

CERTIFICATION

TENSILE RESULTS: ASME Section IX and AWS B2.1, ASTM E21-03a

SOAK TIME: 5 Minutes

SPEED OF TESTING: 0.0050 in./in./min., 0.0500 in./in./min.

MATERIAL: Metrode ER316Mnrf

DISPOSITION: Report

Specimen ID	Testlog Number	Temp. *F/C	UTS KSI/MPA	0.2% YS KSI/MPA	Elong %	RA %	Modulus MS/GPA	Ult. Load LBS/NEWTONS	0.2% YLD. LBS/NEWTONS
T2	B65834	-320/-196	204.7/1410	156.5/1080	29	34	29.9/206	5095/22664	3894/17323

AU/R: A=ACCEPTABLE, U=UNACCEPTABLE, R=REPORT

Specimen ID	Testlog Number	Orig. Dia. (in./mm)	Final Dia. (in./mm)	4D Orig. GL (in./mm)	4D Final GL (in./mm)	Orig. Area (Sq. In./Sq. mm)	Failure Location/Type	Machine Number	AU/R
T2	B65834	0.1780/4.521	0.1444/3.668	0.70/17.78	0.90/22.86	0.02488456/16.054520	WELD/DUCTILE	M9	R

AU/R: A=ACCEPTABLE, U=UNACCEPTABLE, R=REPORT

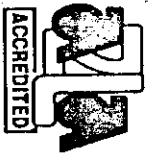

621-01 & 621-02



Section 2 of 2

WMT&R Report No. 5-25008

P.O. No. P05-01764

 Roy E. Starr/Matt Worlon
 Technical Services Manager/Tensile Supervisor

April 20, 2005

42005

Testing Specialists for Aerospace, Automotive, and Material Testing Fields
 Locations in Youngstown, PA U.S.A. ~ TEL (724) 537-3151 and
 Danbury, CT ~ TEL +44 (0) 1295 261211

KNOWNLY OR WILLFULLY FALSIFYING OR CONCEALING A MATERIAL FACT ON THIS FORM
 OR MAKING FALSE, FICTITIOUS OR FRAUDULENT STATEMENTS OR REPRESENTATIONS
 HEREIN COULD CONSTITUTE A FELONY PUNISHABLE UNDER FEDERAL
 STATUTES. THIS CERTIFICATE OR REPORT SHALL NOT BE REPRODUCED
 EXCEPT IN FULL, WITHOUT THE WRITTEN APPROVAL OF WMTR, INC.

WESTMORELAND MECHANICAL TESTING & RESEARCH, Inc

Stress vs. Strain

Phone: (724)537-3131

Customer: Major Tool & Machine Inc.
WMT&R Report: 5-25008

P.O. No.: P05-01764
PQR No.: 434
Welder: Jason Bayer #465

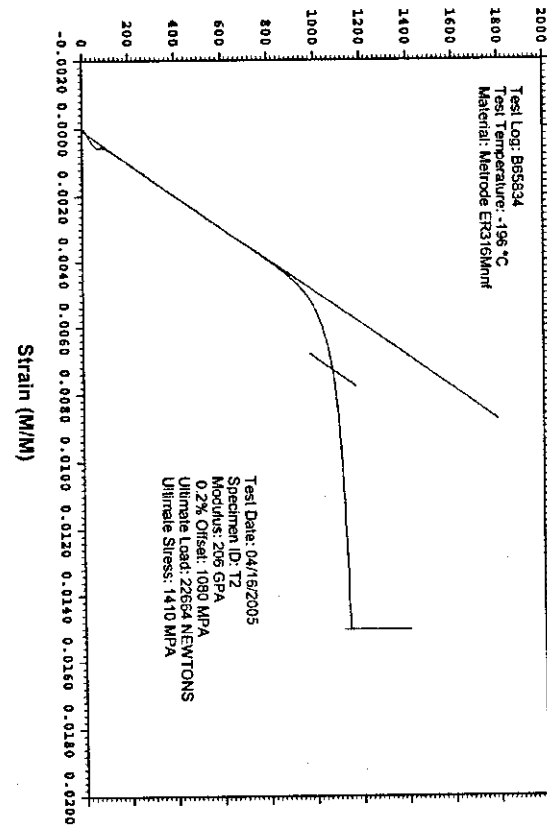
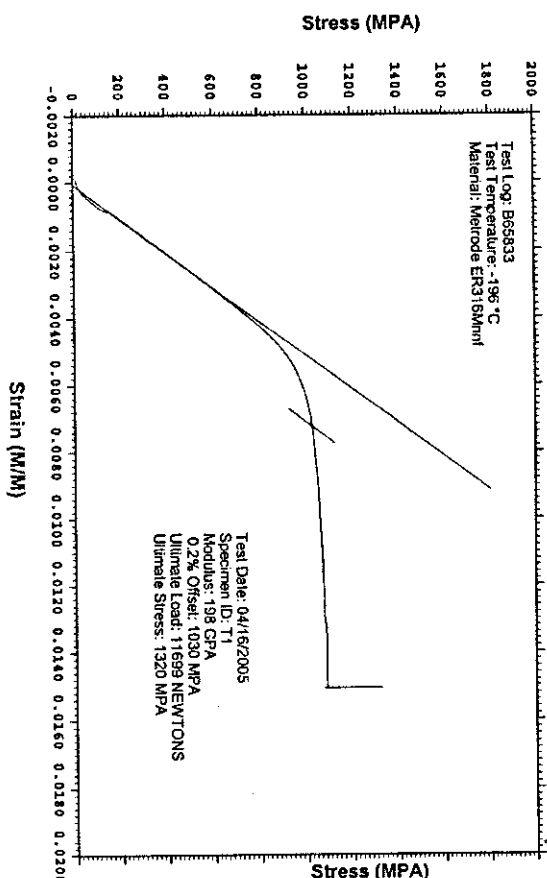
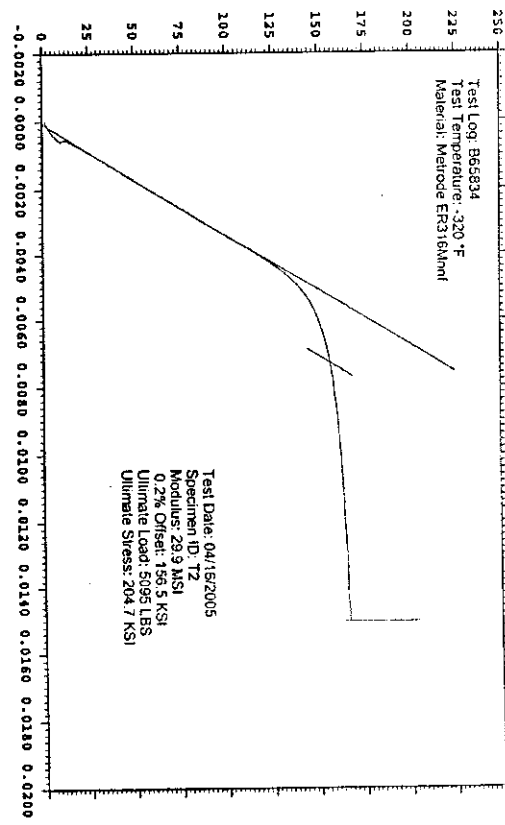
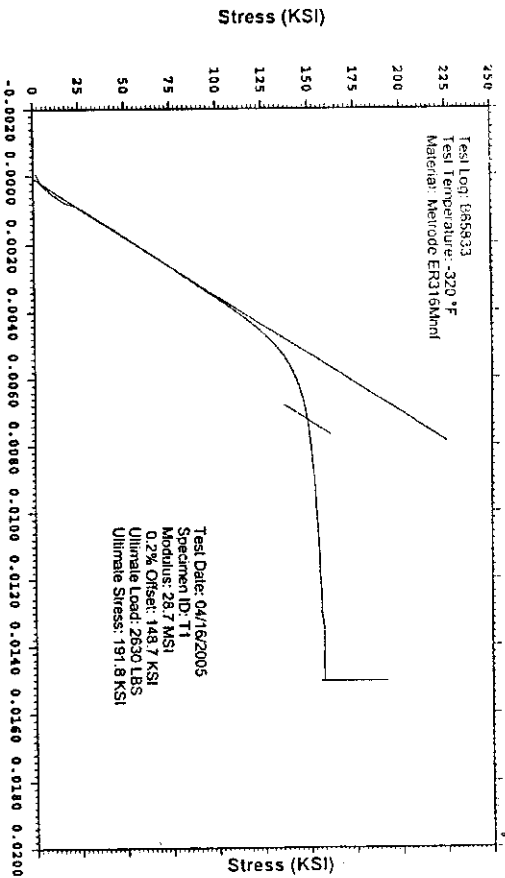

KNOWINGLY OR WILLFULLY FALSIFYING OR CONCEALING A MATERIAL FACT ON THIS FORM OR MAKING FALSE, FICTITIOUS OR FRAUDULENT STATEMENTS OR REPRESENTATIONS HEREIN COULD CONSTITUTE A FELONY PUNISHABLE UNDER FEDERAL STATUTES.

INSPECTION DATA CHECKLIST

Quality Assurance Documentation for Part ID: SE141-116 - Item: 17

Workorder: 65707/2-0 Sub:1 Op:40

Part: SE141-116 - MODULAR COIL WINDING FORM TYPE-C - PRODUCTION MODULAR COIL WINDING FORM TYPE-C

Drawing ID: SE141-116 Rev: 7		INSPECTION INSTRUCTIONS		RESULTS		INSPECTED BY	
SHEET ZONE	CHARACTERISTIC	GAGE/EQUIP	BY SAMPLE	SER#	DATA/REMARKS	INSP	VERFD AUDIT
*	RECORD MAG PERMEABILITY RANGE OF ROUGH MACHINED CASTING. (IN-PROCESS INSPECTION AFTER ROUGH MACHINING OPERATION)	MASTER GAGE	QA	J-1270	16 PLACES TOTAL. CHECKS LESS THAN 1.0 2	854-R.U	
(10)						12-12-05	A

Nondestructive Test Certification for Liquid Penetrant Examination

Quality Assurance Documentation for Part ID: SE141-116 - Item: 18

1458 E. 19th Street, Indianapolis, In 46218
TEL:(317)636-6433 FAX:(317)634-9420

Date of Inspection: 11/25/2005 **Type of Material:** CAST STAINLESS **NDT#:** 14648

Stage of Inspection: <input type="checkbox"/> Incoming Inspection <input type="checkbox"/> In-Process Inspection <input type="checkbox"/> After Repair <input checked="" type="checkbox"/> Final Inspection	Manufacturing Process: <input type="checkbox"/> Weldment <input checked="" type="checkbox"/> Casting <input type="checkbox"/> Bar Stock <input type="checkbox"/> Plate <input type="checkbox"/> Forging <input type="checkbox"/> Other	Surface Condition: <input checked="" type="checkbox"/> Machined <input type="checkbox"/> Rough <input checked="" type="checkbox"/> Other CLEANED & DEBURRED	Test Being Run to: <input checked="" type="checkbox"/> Router Instructions <input checked="" type="checkbox"/> Drawing <input type="checkbox"/> Test Plan <input type="checkbox"/> Technique Card SEE NOTES	Heat Treated: <input checked="" type="checkbox"/> Yes <input type="checkbox"/> No
--	--	--	---	--

Part Information: MTM Job Number: 65707/2.0 -Sub:1 -Op:100 Resource ID: 810-LIQUID PENETRANT INSPE Part ID: SE141-116 Part Name: MODULAR COIL WINDING FOR Serial Number: Customer P.O.: S005242-F Customer Unit/Plant:	Test Results: Quantity Inspected: 1 Quantity Accepted: 0 Quantity Rejected: 1 Run Hours: 0.0	Inspection Results: Customer N/C #: <input type="checkbox"/> Accepted <input checked="" type="checkbox"/> Rejected <input type="checkbox"/> N/C-Report <input type="checkbox"/> Rework MTM N/C #: 18715
--	---	--

Customer Inspection Plan: SEE NOTES Test Step: Revision: Material Test Number:	Inspection Criteria: Customer Specification: ASTM A903/A903M MTM Spec Number: PS582 (REF NDT-WI-09) Acceptance Standard: ASTM A903 (SEE NOTES)
---	---

Inspection Materials Used: Manufacturer: SHERWIN Type of Penetrant: DP-51 Batch Number: 41-E47 Developer: D-100 Batch Number: 520-H6	Penetrant Examination Processes: Type: II (Visible) / Dwell Time: 15 Minutes Method: A (Water Wash) Method of Drying: Normal Evaporation Form: e (nonaqueous for Type II visible dye) / Dwell Time: 12 Min
---	---

Inspection Requirements:

100 % of all accessible surfaces Joint Preps Root Pass Back Gouge Cover Pass Other
 SEE NOTES

Notes:

PT 100% of the part as-cast surfaces as well as finished machine surfaces.
 PART IS REJECTED PER ASTM A903/A903M Level II for as cast surfaces
 ASTM A903/A903M Level I for machined surfaces including the entire "T" section (high stress areas)
 Please reference MTM NC 18715 for additional information.

This is to certify that the pieces specified have been inspected in accordance with the specifications shown.

Inspector: 674-S.WILLIAMS

Date: 11/25/2005

Sylvester Williams Level II P-1

4959

10520 Chester Road
Woodlawn, Ohio 45215



CLIENT Major Tool & Machine	DATE 11/26/05	PO. NO. N/A	DATE 11/26/05
ORDER NO. 13850291	FILM TECHNIQUE N/A	DATE 11/26/05	DATE 11/26/05
OPERATOR Robert Weaver	FILM PROCESS Kodak AA Double	ACCEPTANCE STANDARD No defects > .080"	
EXPOSURE IR 192	TIME 2:30	PERMEATOR ASTM IB	
FILM SPEED 18x108	FOCAL SPOT SIZE .160"	MATERIAL THICKNESS .75"	
FIELD PROCESS N/A	MATERIAL DIAMETER N/A	REMARKS Densitometer-12105 cal due 2/2/06	
DESCRIPTION 65707/20/1/110/818 SE 141-116 rev 6 Page 1 of 2			

FITTING, SEAM OR FITTING	FILM INTERVAL NUMBER	WELDER IDENTIFICATION	PERMEATOR		SLAG	POROSITY	POROSITY WITH TAIL	CRACK	LACK OF PEN	LACK OF FUSION	INTERNAL CONVECTY	INTERNAL CONVEXITY	INTERNAL UNDERCUT	EXTERNAL UNDERCUT	ALIGNED INDICATIONS	WELD CONTOUR	RE-SPATCH	FILM ATTACK	VISUAL CONCERNS	FILM DENSITY	SEE REMARKS	ACCEPT	REJECT		
			SIZE	QUALITY LEVEL																					
T501	0-1	N/A	IB	.016"	✓																				
	1-2																								
	2-3																								
	3-4																								
	4-5																								

<input type="checkbox"/> End View <input type="checkbox"/> Side View <input type="checkbox"/> SINGLE WALL <input type="checkbox"/> DOUBLE WALL	<input type="checkbox"/> Penetration <input type="checkbox"/> Lack of Fusion <input type="checkbox"/> Location Mark <input type="checkbox"/> OTHER
---	---

11/26/05

Robert Weaver

Customer Representative Signature

Cooperheat's Signature

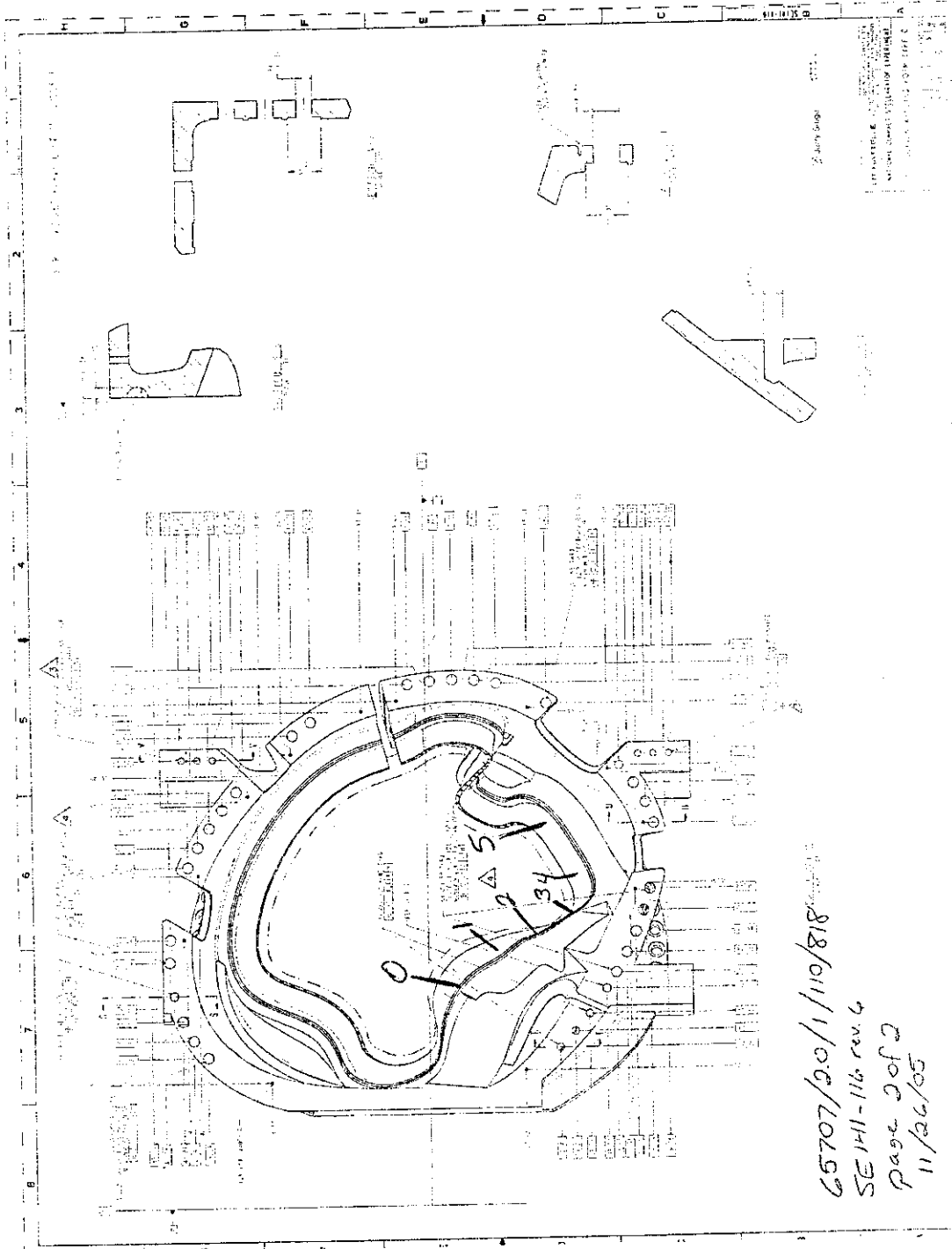



Major
Tool & Machine, Inc.

INSPECTION DATA CHECKLIST

Quality Assurance Documentation for Part ID: SE141-116 - Item: 20

Workorder: 65707/2-0 Sub:1 Op:121

Part: SE141-116 - MODULAR COIL WINDING FORM TYPE-C - PRODUCTION MODULAR COIL WINDING FORM TYPE-C

SHEET	ZONE	CHARACTERISTIC	INSPECTION INSTRUCTIONS			RESULTS		INSPECTED BY		
			GAGE/EQUIP	BY SAMPLE	SER#	DATA/REMARKS	INSP	VERFD	AUDIT	
6*	F2	\square .02	CMM	QA	00064	.003		339-E.R		A
(510)								11-25-05		
6*	F2	1.125 ± .010	CMM	QA	00064	1.126 - 1.135		339-E.R		A
(520)								11-25-05		
6*	F2	2.250 ± .010	CMM	QA	00064	2.240 - 2.252		339-E.R		A
(530)								11-25-05		
6*	E2	Φ .01 F P V	CMM	QA	00064	0.01		339-E.R		A
(540)		7X Ø1.625 THRU BOTH SIDES						11-25-05		



Major
Tool & Machine, Inc.

INSPECTION DATA CHECKLIST

Quality Assurance Documentation for Part ID: SE141-116 - Item: 21

Workorder: 65707/2-0 Sub:1 Op:134

Part: SE141-116 - MODULAR COIL WINDING FORM TYPE-C - PRODUCTION MODULAR COIL WINDING FORM TYPE-C

SHEET		ZONE	CHARACTERISTIC	INSPECTION INSTRUCTIONS			RESULTS		INSPECTED BY			
				GAGE/EQUIP	BY	SAMPLE	SER#	DATA/REMARKS	INSP	VERFD	AUDIT	
1*	(10)	E8	47.19 ± .03	CMM	QA		00064	47.178 - 47.183	339-E.R	12-07-05		A
1*	(11)	G8	R17.00 +.25 -.00	CMM	QA		00064	17.035 - 17.070	339-E.R	12-07-05		A
1*	(20)	B8	47.19 ± .03	CMM	QA		00064	47.187 - 47.191	339-E.R	12-07-05		A
1*	(30)	D6	47.19 ± .03	CMM	QA		00064	47.192 - 47.195	339-E.R	12-07-05		A
1*	(40)	C6	47.19 ± .03	CMM	QA		00064	47.186 - 47.191	339-E.R	12-07-05		A
1*	(50)		// .02 A	CMM	QA		00064	.005	339-E.R	12-07-05		A
1*	(60)	B6	// .02 A	CMM	QA		00064	.006	339-E.R	12-07-05		A
1*	(70)	F3	□ .5 A B C	CMM	QA		00064	REFERENCE IGES DAT	339-E.R	12-12-05		A
2*	(80)	H6	2X R.187 +.025 -.005	INDICATOR	QA		J-651	.185 - .187	339-E.R	12-07-05		A
2*	(90)	G8	2X .03 X 45°		QA		VISUAL	ACCEPT	339-E.R	12-12-05		A
2*	(100)	G8	.40 ± .010	CALIPER	QA		J-707	0.40 - 0.41	339-E.R	12-07-05		A
2*	(110)	G8	2X .030 X 45°		QA		VISUAL	ACCEPT	339-E.R	12-12-05		A
2*	(120)	F7	2X .32	CALIPER	QA		J-707	.32 - .33	339-E.R	12-07-05		A
2*	(130)	F7	2X R.11	RADIUS GAGE	QA		R-25	.12	339-E.R	12-07-05		A
2*	(140)	G6	□ .1 R S T P.T.O.M	CMM	QA		00064	REFERENCE IGES DAT	339-E.R	12-12-05		R
2*		G6	4.790 ± .005		QA		VISUAL	ACCEPT	339-E.R	12-12-05		A



Major
Tool & Machine, Inc.

INSPECTION DATA CHECKLIST

4*	H7	3 X SPHERICAL R.750 +.002 / -.003 TOLERANCE CHANGE PER RFD 14-009 ITEM 5. DATUM -D- FLANGE.	CMM	QA	00064	.753 / .764 / .763	339-E.R	R
(295)							12-12-05	
4*	H7	Φ Ø.01 D A N	CMM	QA	00064	TP .020 / .74 DEEP	339-E.R	R
(300)			DEPTH MICROMET		J-1024		12-12-05	
4*	H6	Φ Ø.01 D A N 17X Ø1.88 THRU Ø3.00 BACK SPOTFACE MIN TO CLEANUP	CMM	QA	00064	0.102 / 1.87 - 1.88 / 3.00 CLEAN UP	339-E.R	R
(310)							12-07-05	
4*	H5	Φ Ø.01 D A N 3X Ø1.13 Ø2.38 BACK SPOTFACE MIN TO CLEANUP	CMM	QA	00064	0.041 / 1.12 - 1.13 / 3.2 CLEAN UP	339-E.R	R
(320)							12-07-05	
4*	E6	Φ Ø.01 D A N	CMM	QA	00064	.038 / ACCEPT THREA	339-E.R	R
(340)			THREAD PLUG GA		A-375	DS	12-07-05	
4*	E6	Φ Ø.01 D A N 5X Ø1.88 THRU Ø3.00 BACK SPOTFACE MIN TO CLEANUP	CMM	QA	00064	.0182 / 1.87 - 1.88 / 2.98 - 2.99	339-E.R	R
(350)			CALIPER		J-707		12-07-05	
4*	D4	Φ Ø.01 D A N Ø1.88 THRU Ø3.00 BACK SPOTFACE MIN TO CLEANUP	CMM	QA	00064	.0184 / 1.88 / 2.99	339-E.R	R
(360)			CALIPER		J-707		12-07-05	
4*	B5	Φ Ø.01 D A N 3X Ø1.13 Ø2.38 BACK SPOTFACE MIN TO CLEANUP	CMM	QA	00064	.028 / 1.13 - 1.27 / 3.2 CLEAN UP	339-E.R	R
(370)			SCALE		J-922		12-07-05	
5*	E8	Φ Ø.01 E A J Ø1.88 THRU Ø3.00 BACK SPOTFACE MIN TO CLEANUP	CMM	QA	00064	.015	339-E.R	R
(380)			THREAD PLUG GA		A-375	ACCEPT	12-07-05	A
5*	F6	3X Ø1.375-6 UNC √1.25	THREAD PLUG GA	QA			339-E.R	A
(400)							12-07-05	
5*	F6	3 X SPHERICAL R.750 +.002 / -.003 TOLERANCE CHANGE PER	CMM	QA	00064	.758 / .752 / .750	339-E.R	A



Major
Tool & Machine, Inc.

INSPECTION DATA CHECKLIST

SHEET ZONE	CHARACTERISTIC	GAGE/EQUIP	BY SAMPLE	SER#	DATA/REMARKS	INSP	VERFD	INSPECTED BY	REFERENCE IGES DAT		R
									INSP	VERFD	
10* (1020)		CMM	QA	00064		339-E.R			12-12-05		R
10* (1030)		CMM	QA	00064		339-E.R			12-12-05		R
Drawing ID: NCSX-CSPEC-141-03 Rev: 10											
CHARACTERISTIC											
4* (1040)	3.1.1. UOS ALL MACHINED SURFACES TO BE 250 RMS SURFACE FINISH RECORD RANGE	PROFILOMETER	QA	J-1152	85 - 230	339-E.R					A
Drawing ID: SE141-116 Rev: 7											
CHARACTERISTIC											
1*	RECORD THE WEIGHT OF THE PART 6000LBS MAX		QA		5620 LBS	242-M.G					A
4* (1050)		CMM	QA	00064	22.12	12-15-05					A
4* (1060)		CMM	QA	00064	47.776	12-07-05					R
4* (1070)		CMM	QA	00064	59.176	12-07-05					A
4* (1080)		CMM	QA	00064	73.265	12-07-05					A
4* (1090)		CMM	QA	00064	80.469	12-07-05					R
4* (1100)		CMM	QA	00064	87.838	12-07-05					R
4* (1110)		CMM	QA	00064	89.584	339-E.R					R
4* (1120)		CMM	QA	00064	31.827	12-12-05					A
4* (1130)		CMM	QA	00064	24.097	12-07-05					A
4* (1140)		CMM	QA	00064	11.463	12-07-05					R
4* (1150)		CMM	QA	00064	5.201	12-12-05					A

INSPECTION DATA CHECKLIST

Quality Assurance Documentation for Part ID: SE141-116 - Item: 22

Workorder: 65707/2-0 Sub:1 Op:140

Part: SE141-116 - MODULAR COIL WINDING FORM TYPE-C - PRODUCTION MODULAR COIL WINDING FORM TYPE-C

SHEET ZONE	Drawing ID: SE141-103 Rev: 2 CHARACTERISTIC	INSPECTION INSTRUCTIONS			RESULTS		INSPECTED BY	
		GAGE/EQUIP	BY SAMPLE	SER#	DATA/REMARKS	INSP	VERFD	AUDIT
*	INSPECT AND RECORD RESISTANCE ACROSS BOLT INSUL. VALUE TO BE >500 KOHM'S		QA		110 MEGA OHMS	840-G.M		
(10)								
*	INSPECT AND RECORD RANGE OF RESISTANCE ACROSS POLOIDAL BREAK MIDPLANE AND BOLTS VALUE TO BE >500 KOHM'S		QA		110 MEGA OHMS	840-G.M		
(20)								



1458 E. 19th Street, Indianapolis, In 46218
 TEL:(317)636-6433 FAX:(317)634-9420

Nondestructive Test Certification for Liquid Penetrant Examination

Quality Assurance Documentation for Part ID: SE141-116 - Item: 23

Date of Inspection: 12/12/2005 **Type of Material:** CAST STAINLESS **NDT#:** 14900

Stage of Inspection: <input type="checkbox"/> Incoming Inspection <input type="checkbox"/> In-Process Inspection <input checked="" type="checkbox"/> After Repair <input type="checkbox"/> Final Inspection	Manufacturing Process: <input type="checkbox"/> Weldment <input checked="" type="checkbox"/> Casting <input type="checkbox"/> Bar Stock <input type="checkbox"/> Plate <input type="checkbox"/> Forging <input type="checkbox"/> Other	Surface Condition: <input checked="" type="checkbox"/> Machined <input type="checkbox"/> Rough <input checked="" type="checkbox"/> Other CLEANED & DEBURRED	Test Being Run to: <input checked="" type="checkbox"/> Router Instructions <input checked="" type="checkbox"/> Drawing <input type="checkbox"/> Test Plan <input type="checkbox"/> Technique Card SEE NOTES	Heat Treated: <input checked="" type="checkbox"/> Yes <input type="checkbox"/> No
--	--	--	---	--

Part Information: MTM Job Number: 65707/2.0 -Sub:16 -Op:20 Resource ID: 810-LIQUID PENETRANT INSPE Part ID: SE141-116 Part Name: MODULAR COIL WINDING FOR Serial Number: Customer P.O.: S005242-F Customer Unit/Plant:	Test Results: Quantity Inspected: 1 Quantity Accepted: 0 Quantity Rejected: 1 Run Hours: 0.0	Inspection Results: Customer N/C #: <input type="checkbox"/> Accepted <input checked="" type="checkbox"/> Rejected <input type="checkbox"/> N/C-Report <input type="checkbox"/> Rework MTM N/C #: 18715
--	---	--

Customer Inspection Plan: SEE NOTES Test Step: Revision: Material Test Number:	Inspection Criteria: Customer Specification: ASTM A903/A903M MTM Spec Number: PS582 (REF NDT-WI-09) Acceptance Standard: ASTM A903 (SEE NOTES)
---	---

Inspection Materials Used: Manufacturer: SHERWIN Type of Penetrant: DP-51 Batch Number: 41-E47 Developer: D-100 Batch Number: 520-H6	Penetrant Examination Processes: Type: II (Visible) / Dwell Time: 15 Minutes Method: A (Water Wash) Method of Drying: Normal Evaporation Form: e (nonaqueous for Type II visible dye) / Dwell Time: 12 Min
---	---

Inspection Requirements:

% of all accessible surfaces
 Joint Preps
 Root Pass
 Back Gouge
 Cover Pass
 Other
 SEE NOTES

Notes:
 PERFORM A LOCAL LPI CHECK OF THE 3 PREVIOUSLY REJECTED AREAS. THERE WAS 1 REJECTION ON THE MACHINED T AND 2 REJECTIONS IN THE AS-CAST REGION.

Please reference MTM NC 18715 for additional information.

Specification: ASTM A903/A903M
 Method: ASTM E165
 Acceptance Criteria: ASTM A903/A903M Level II for as cast surfaces
 Acceptance Criteria: ASTM A903/A903M Level I for machined surfaces including the entire "T" section (high stress areas)

2 indications remain after excavation, one on the finished machine area, and one in the as cast surface.

This is to certify that the pieces specified have been inspected in accordance with the specifications shown.

Inspector: 581-D.EDWARDS

Date: 12/12/2005

Douglas D. Edwards Level II





Major
Tool & Machine, Inc.

INSPECTION DATA CHECKLIST

Quality Assurance Documentation for Part ID: SE141-116 - Item: 24

Workorder: 65707/2-0 Sub:14 Op:10

Part: SE141-116 - -

Drawing ID: SE141-116 Rev: 7		INSPECTION INSTRUCTIONS		RESULTS		INSPECTED BY			
SHEET	ZONE	CHARACTERISTIC	GAGE/EQUIP	BY SAMPLE	SER#	DATA/REMARKS	INSP	VERFD	AUDIT
*		RECORD RANGE UPPER AND LOWER LIMITS OF MAG PERMEABILITY READI (Mu) FOR THE AS CAST SURFACES	MASTER GAGE	QA	J-1270	ALL CAST SURFACES HECK LESS THAN 1.02	854-R.U		
(10)							11-27-05		
*		RECORD RANGE UPPER AND LOWER LIMITS OF MAG PERMEABILITY READI (Mu) FOR THE MACHINED SURFACES	MASTER GAGE	QA	J-1270	< 1.02	854-R.U		
(20)							12-12-05		
*		MAG PERMEABILITY WAS PERFORMED USING A 6" X 6" GRID ON ALL CAST SURFACES AND A 2"X2" GRID ON ALL MACHINED SURFACES. PICTURES OF GRID HAVE BEEN SUPPLIED.	MASTER GAGE	QA	J-1270	< 1.02	854-R.U		
19	(30)						12-12-05		

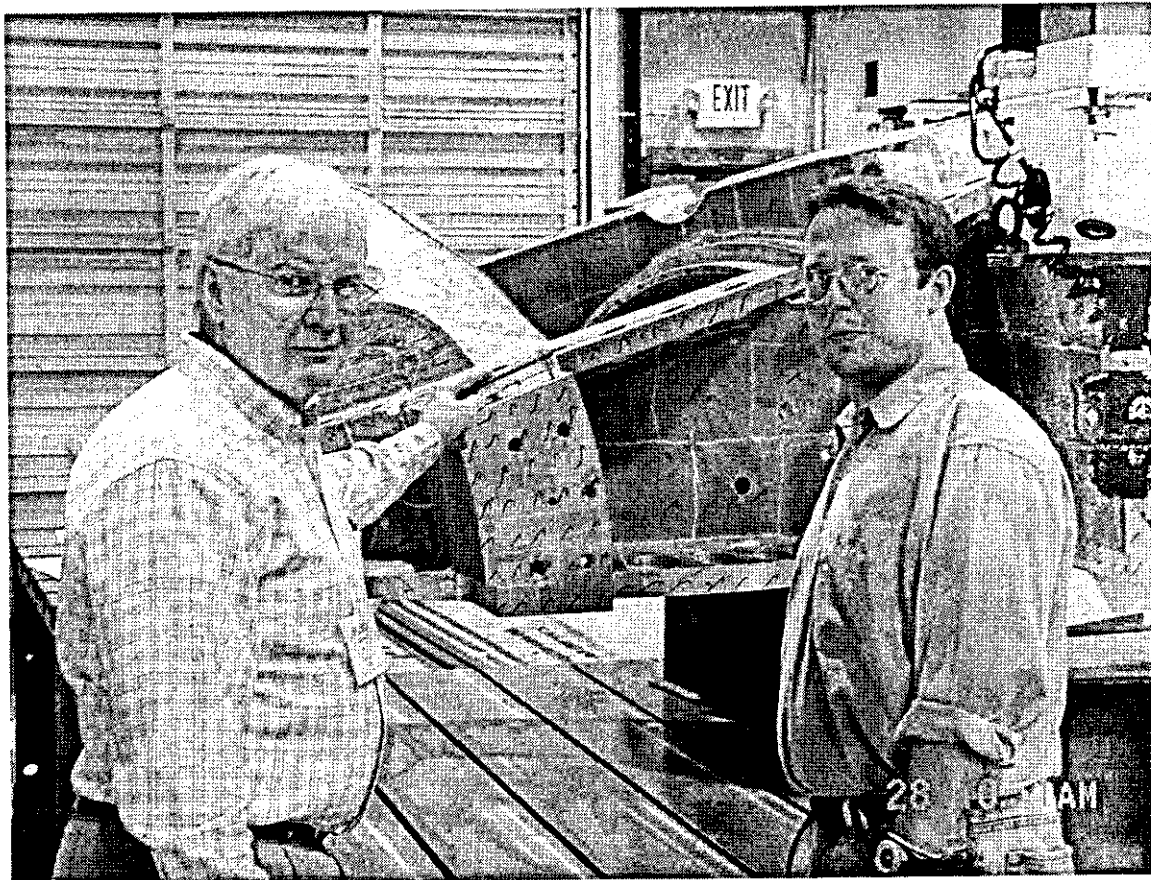



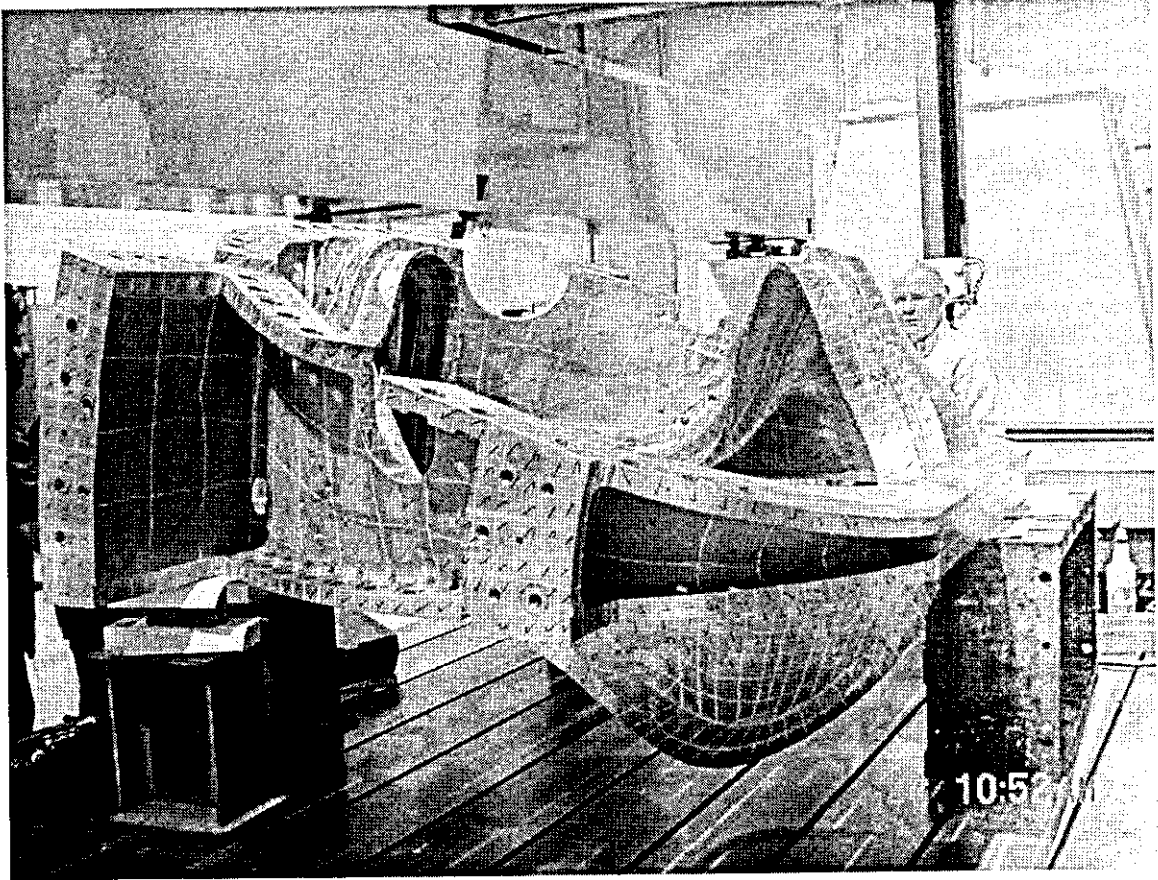

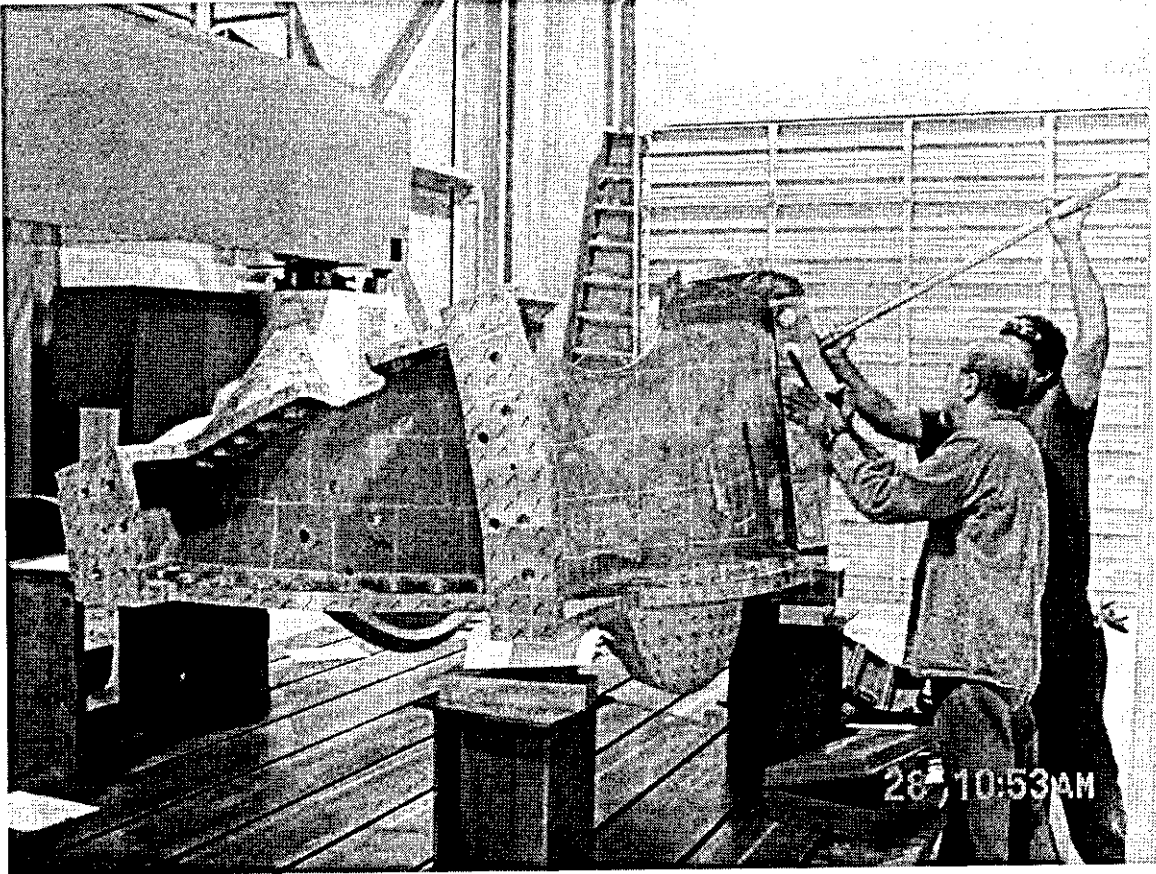



CERTIFICATE OF TEST

Page 01 of 02

Certification Date
21-NOV-2005

CUSTOMER ORDER NUMBER
P05-06516
CUSTOMER PART NUMBER
522335

EARLE M. JORGENSEN COMPANY
2301 AIRWEST BLVD
PLAINFIELD IN 46168

Invoice Number
T474338

SOLD TO: MAJOR TOOL & MACHINE INC **SHIP TO:** MAJOR TOOL & MACHINE INC
1458 E 19TH ST 29267
INDIANAPOLIS IN 46218 1458 EAST 19TH STREET
INDIANAPOLIS IN 46218

Description: 316/316L HRAP BAR ASTM A479
1 X 3 X 12' R/L Line Total: 135 LB
HEAT: M11443 ITEM: 522335

Specifications:
ASTM A479 03 ASTM A276 03 ASME SA479 01
QQ S 763 98 AMS 5648 K02 AMS 5653 F02
AS TM A4 AMS QQ S 763 98 ASTM A182 03
ASTM A193 03 SATM A322 03 ASME SB182 00B

CHEMICAL ANALYSIS

C	SI	MN	P	S	CR	MO	NI
0.03	0.57	1.25	0.037	0.024	16.84	2.0	10.63
V	W	CO	TI	AL	NB	N	CU
0.03	0.07	0.057	3.05	0.059	0.01	0.04	0.27

RCPT: R534135 COUNTRY OF ORIGIN : AUSTRIA
MILL : AMS SPECIALTY STEEL

MECHANICAL PROPERTIES

DESCRIPTION	YLD STR	ULT TEN	%ELONG	%RED	HARDNESS
	KSI	KSI	IN 02 IN	IN AREA	BHN
	58.0	91.0	44.0	71.0	194

GRAIN SIZE : 10



NOV 28 2005

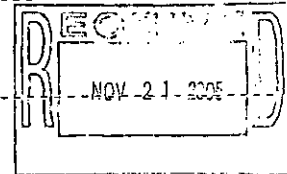
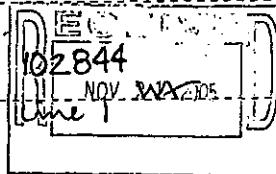

The above data were transcribed from the manufacturer's Certificate of Test after verification for completeness and specification requirements of the information on the certificate. All test results remain on file subject to examination.

We hereby certify that the material covered by this report will meet the applicable requirements described herein, including any specification forming a part of the description.

The willful recording of false, fictitious, or fraudulent statements in connection with test results may be punishable as a felony under federal statutes.

Material did not come in contact with mercury while in our possession.

DAMIAN GURRI

MANAGER, QUALITY ASSURANCE



CERTIFICATE OF TEST

Page 02 of 02

Certification Date
21-NOV-2005

CUSTOMER ORDER NUMBER
P05-06516
CUSTOMER PART NUMBER
522335

EARLE M. JORGENSEN COMPANY
2301 AIRWEST BLVD
PLAINFIELD IN 46168

Invoice Number
T474338

SOLD TO:	MAJOR TOOL & MACHINE INC	SHIP TO:	MAJOR TOOL & MACHINE INC
	1458 E 19TH ST		29267
	INDIANAPOLIS IN 46218		1458 EAST 19TH STREET
			INDIANAPOLIS IN 46218

Description:	316/316L HRAP BAR	ASTM A479
1 X 3 X 12' R/L		Line Total: 135 LB
HEAT: M11443	ITEM: 522335	

THERMAL TREATMENT: OK
HT TRT QUENCHED 1040 DEG C 30 MIN WATER
CORROSION: OK
MACRO: OK
MICRO1: OK



NOV 28 2005

The above data were transcribed from the manufacturer's Certificate of Test after verification for completeness and specification requirements of the information on the certificate. All test results remain on file subject to examination.

We hereby certify that the material covered by this report will meet the applicable requirements described herein, including any specification forming a part of the description.

The willful recording of false, fictitious, or fraudulent statements in connection with test results may be punishable as a felony under federal statutes.

Material did not come in contact with mercury while in our possession.

DAMIAN GURRI

MANAGER, QUALITY ASSURANCE

INSPECTION DATA CHECKLIST

Quality Assurance Documentation for Part ID: SE141-137 - Item: 30

Workorder: 65707/2-0 Sub:12 Op:40

Part: SE141-137 - -		Drawing ID: SE141-137 Rev: 0		INSPECTION INSTRUCTIONS		RESULTS		INSPECTED BY		
SHEET	ZONE	CHARACTERISTIC	GAGE/EQUIP	BY	SAMPLE	SER#	DATA/REMARKS	INSP	VERFD	AUDIT
1*	G2	VERIFY MAGNETIC PERMEABILITY IS LESS THAN 1.02μ PER DRAWING NOTE 5.	MASTER GAGE	QA		J-1270	BETWEEN 1.02 AND 1.03 (REFERENCE RFD14-011 FOR ACCEPTANCE)	503-B.H		242-M.G.R
(10)								11-23-05		02-04-06





Major

Tool & Machine, Inc.

INSPECTION DATA CHECKLIST

Quality Assurance Documentation for Part ID: SE141-138 - Item: 32

Workorder: 65707/2-0 Sub:13 Op:40

Part: SE141-138 - -

SHEET	ZONE	DRAWING ID: SE141-138 Rev: 0 CHARACTERISTIC	INSPECTION INSTRUCTIONS		RESULTS	INSPECTED BY	
			GAGE/EQUIP	BY SAMPLE		INSP	VERFD / AUDIT
1*	G2	VERIFY MAGNETIC PERMEABILITY IS LESS THAN 1.02μ PER DRAWING NOTE 5.	MASTER GAGE	QA	GREATER THAN 1.02 A ND LESS THAN 1.03 (CHANGED FROM 1.05 O 1.03) (REFERENCE RFD14-011 FOR ACCEP TANCE)	242-M.G	242-M.G R
(10)						02-04-06	02-04-06

Employees: 212-J.Lehr / 242-M.Griffith / 321-C.Lonaker / 339-E.Root / 503-B.Houk / 840-G.Masood / 854-R.Upchurch

Customer: ENERGY INDUSTRIES OF OHIO

Contact: NANCY HORTON
E-Mail: NKHFlowen@aol.com

Telephone: 216-496-2314
Fax: 216-328-2001

Part: ER316MNNF_093_GTAW / WELD WIRE,GTAW .093 DI
Drawing ID: Revision:

Customer P.O.: S005242-F/Ln:1
Serial No./Qty: C1

Reported By: MIKE GRIFFITH
E-Mail: mGriffith@MajorTool.com

Telephone: 317-636-6433
Fax: 317-634-9420

Problem: NCSX-CSPEC-141-03-10 section 3.1.1.2 table 3-4 requires Elongation percentage to be a minimum of 32% at 77K.
Actual test results for elongation are 27%.

Proposed Disposition:

Major Tool proposes that the elongation percentage be accepted as is and the specification be revised to include this elongation percentage.

Number of additional pages: _____

Customer Disposition: Use As Is Rework Repair Scrap Replace

NCSX-CSPEC-141-03-10, Sect. 3.1.1.2, Table 3-4 was revised; the min. elongation at 77 K is now specified to be 25%. This is still adequate ductility.

Tech. Rep. Approval

Phil
Heitzenroeder

Digitally signed by Phil Heitzenroeder
DN: CN = Phil Heitzenroeder, C = US,
O = PPPL, OU = Mech. Eng. Division
Reason: I agree to 'specified' portions
of this document
Date: 2005.12.15 13:00:26 -05'00'

RLM Approval:

Brad
Nelson

Digitally signed by Brad Nelson
DN: cn=Brad Nelson, c=US,
o=ORNL, ou=FED,
email=nelsonbe@ornl.gov
Date: 2005.12.15 17:01:45
-05'00'

Major Tool Implemented By: 

Title: CST ENG INSR

Date: 1/16/2006

Major Tool & Machine, Inc.
1458 East 19th Street
Indianapolis, IN 46218-4289

MTM N/C: 18831

Page: 1
Date: 12/09/05
User ID: GRIFFITH

Customer: ENERGY INDUSTRIES OF OHIO

Contact: NANCY HORTON
E-Mail: NKHFlowen@aol.com

Telephone: 216-496-2314
Fax: 216-328-2001

Part: ER316MNNF_093_GTAW / WELD WIRE,GTAW .093 DI
Drawing ID: Revision:

Customer P.O.: S005242-F/Ln:1
Serial No./Qty: C1

Reported By: MIKE GRIFFITH
E-Mail: mGriffith@MajorTool.com

Telephone: 317-636-6433
Fax: 317-634-9420

Problem: Actual results for the room temperature Tensile Test were not supplied on the material test report.

Proposed Disposition:

Metrode has supplied conforming test results from a previously tested batch of weld wire. Major Tool is proposing that these results be used for acceptance as they are representative of the actual wire used by Major Tool.

Number of additional pages: _____

Customer Disposition: Use As Is Rework Repair Scrap Replace

MTM has the chemistry certification for this batch. Since it is in conformance, the test results from the previously tested batch will be applicable to this batch.

NCSX will revise the spec with Rev. 11 to accept "typical" test results of weld wire that has certified chemistry.

Major Tool Implemented By: 

Title: CFT ENGINEER Date: 1/2/06

Tech. Rep. Approval:

Phil
Heitzenroeder

Digitally signed by Phil Heitzenroeder
DN: CN = Phil Heitzenroeder, C =
US, O = PPPL, OU = Mech. Eng.
Division
Reason: I agree to specified portions
of this document
Date: 2006.01.09 17:07:36 -05'00'

RLM Approval:

Brad
Nelson

Digitally signed by Brad Nelson
DN: cn=Brad Nelson, c=US,
o=ORNL, ou=FED,
email=nelsonbe@ornl.gov
Date: 2006.01.10 15:55:50
-05'00'