

Energy Industries of Ohio

Contract # S005242-F

Modular Coil Winding Form

C-5 Documentation Package

8/9/06

This C-5 Documentation consists of:

Part 1

**Final documentation package Metal Tek Intl. – Pages 3 – 96
Latest revision 7/18/2006
Foundry documentation**

Part 2

**Final documentation package Major Tool - Pages 97 - 213
Latest revision 7/18/2006
Machine shop documentation**

Part 3

Metal Tek radiographic films from part 1 (shipped to PPPL)

Major Tool radiographic films from part 2 (shipped to PPPL)

Part 4

Notes, corrections & additions – 8/9/06

- 1. MTM – new EIO TOC is on page 98. Use this as a reference for finding files in MTM portion of Doc package.**
- 2. EIO CA 32206 for thin flange condition has been added to the end of the MTM Doc package – Page 214**

Energy Industries of Ohio

Contract # S005242-F

Modular Coil Winding Forms

C-5 Documentation Package

**Part 1 – Metal Tek International
Casting Data Package**

Revised 7/18/2006

**Note – Document #'s listed in the TOC (page 4) are not necessarily the same as the number hand written on the top of the document. Please use page # to find relevant document.

C-5 Documentation Package

List of Documents 7-18-06

Doc #	Description	Page #
1	MTR for 3 ladles + weighted av. Of chemistry – Original – superseded by MTR from WC & new MTR from MTK (Doc # 1-3)	5
2	MTR from Wisconsin Centrifugal for 3 ladles + weighted av. of chem..	9
3	MTR for 3 ladles + weighted av. Of chem. after preventive maintenance	13
4	MTR for C-5 Shim dated 9/24/05	17
5	Lincoln weld metal product conformance spec Lot 3018926/78309	18
6	St Louis Test Lab dated 8/9/05 mech test results at RT & Charpy V notch @ 293°k for Lincoln lot 3018926/78308 – NOTE page 3 of 3 NA C-5	19
7	Westmoreland mech test & CVN @ -320°F – 9/13/05 Lot 3018926/78309	22
8	Lincoln weld metal product conformance spec Lot 3018513/78308	24
9	St Louis Test Lab dated 8/16/05 mech test results at RT & Charpy V notch @ 293°k for Lincoln lot 3018513/78308	25
10	Westmoreland mech test @ -320°F dated 10/18/05 Lot 3018513/78308	27
11	St Louis Test Lab -10/5/05 CVN @ -320°F Lincoln Lot # 3018513/78308	28
12	Westmoreland Tensile test report @ -320°F dated 10-18-05	29
13	Westmoreland Tensile test report @ -320°F dated 10-21-05 - retest	30
14	St Louis Test Lab dated 8-18-05 – incl. tensile test results @ room temp & Charpy V Notch (CVN) at 77°K & 293°K	32
15	Weld map	35
16	Radiographic Standard Shooting Sketch	44
17	Radiographic Standard Shooting Sketch – C-shims	45
18	MQS Radiographic Inspection Report dated 8/31/05	48
19	MQS Radiographic Inspection Report dated 10/13/05	54
20	MTK Radiographic Interpretation Report dated 11/07/05	57
21	MTK Radiographic Interpretation Report C-5 shim dated 11/08/05	58
22	C-5 Coil heat treat chart dated 8/13/05	59
23	C-5 Coil stress relief dated 11-14-05	60
24	C-5 Shim heat treat chart dated 6-02-05	61
25	MTK signed MTS C-5 Coil	62
26	MTK signed MTS C-5 Coil shim	73
27	CA 1308 – shim chemistry out of spec	79
28	CA 1323 – revised & inserted 3/16/06	81
29	CA 1379 Failed weld test on Lincoln weld metal # 3018926/78309	86
30	CA 1454 for 31% elongation on C-5	88
31	Final inspection report C-5 Coil dated 11/04/05	91
32	C of C for C-5 Coil dated 11/04/05	92
33	Final Inspection report C-5 shim dated 10/28/05	93
34	C of C for C–5 shim dated 10/28/05	94
35	EIO shipping release for C-5 dated 11/23/05	95
7/18/06		



Carondelet Division

8600 Commercial Blvd. - Pevely, MO 63070 USA
Phone: 636-479-4499 - Fax: 636-479-3399

Material Test Report

ENERGY INDUSTRIES OF OHIO

Purchase Order Number PPPL-FP-LTS-2
Pattern Number MCWF-C5 Coil
CAF Metal Designation CF8MNMnMod
Material Spec CF8MNMnMOD
Ladle#1 Heat 30441
Original Chemistry

Cert Number 172810-1
Pour Date 8/8/2005

Element	Min	Actual	Max
C	0.04	0.05	0.07
MN	2.3	2.6	2.8
SI	0.0	0.3	0.7
CR	18.0	18.2	18.5
NI	13.0	13.3	13.5
MO	2.1	2.3	2.5
P	0.0	0.023	0.035
S	0.0	0.011	0.025
N	0.24	0.26	0.28

Respectfully Submitted,
Charles A. Ruud
Quality Assurance Manager



2

Carondelet Division

8600 Commercial Blvd. - Pevely, MO 63070 USA
Phone: 636-479-4499 - Fax: 636-479-3399

Material Test Report

ENERGY INDUSTRIES OF OHIO

Purchase Order Number PPPL-FP-LTS-2
Pattern Number MCWF-C5 Coil
CAF Metal Designation CF8MNMnMod
Material Spec CF8MNMnMOD
Ladle#2 Heat 30442
Original Chemistry

Cert Number 172810-1
Pour Date 8/8/2005

Element	Min	Actual	Max
C	0.04	0.05	0.07
MN	2.3	2.4	2.8
SI	0.0	0.4	0.7
CR	18.0	18.2	18.5
NI	13.0	13.3	13.5
MO	2.1	2.3	2.5
P	0.0	0.033	0.035
S	0.0	0.013	0.025
N	0.24	0.24	0.28

Respectfully Submitted,
Charles A. Ruud
Quality Assurance Manager



3

Carondelet Division

8600 Commercial Blvd. - Pevely, MO 63070 USA
Phone: 636-479-4499 - Fax: 636-479-3399

Material Test Report

ENERGY INDUSTRIES OF OHIO

Purchase Order Number PPPL-FP-LTS-2
Pattern Number MCWF-C5 Coil
CAF Metal Designation CF8MNMnMod
Material Spec CF8MNMnMOD
Ladle#3 Heat 30445
Original Chemistry

Cert Number 172810-1
Pour Date 8/8/2005

Element	Min	Actual	Max
C	0.04	0.05	0.07
MN	2.3	2.4	2.8
SI	0.0	0.3	0.7
CR	18.0	18.3	18.5
NI	13.0	13.2	13.5
MO	2.1	2.4	2.5
P	0.0	0.03	0.035
S	0.0	0.01	0.025
N	0.24	0.25	0.28

Respectfully Submitted,
Charles A. Ruud
Quality Assurance Manager



4

Carondelet Division

8600 Commercial Blvd. - Pevely, MO 63070 USA
Phone: 636-479-4499 - Fax: 636-479-3399

Material Test Report

ENERGY INDUSTRIES OF OHIO

Purchase Order Number PPPL-FP-LTS-2

Cert Number 172810-1

Pattern Number MCWF-C5

Pour Date 8/8/2005

CAF Metal Designation CF8MNMnMod

Material Spec CF8MNMnMOD

Weighted average of 3 heats - 30441(39%),30442(21%),30445(40%) Total Weight 31732 lbs.

Original Chemistry

Element	Min	Actual	Max
C	0.04	0.05	0.07
MN	2.3	2.5	2.8
SI	0.0	0.3	0.7
CR	18.0	18.2	18.5
NI	13.0	13.3	13.5
MO	2.1	2.3	2.5
P	0.0	0.028	0.035
S	0.0	0.011	0.025
N	0.24	0.25	0.28

A handwritten signature in black ink, appearing to read "CARU", is located above the typed name of the Quality Assurance Manager.

Respectfully Submitted,
Charles A. Ruud
Quality Assurance Manager



1A

Carondelet Division

8600 Commercial Blvd. - Pevely, MO 63070 USA
Phone: 636-479-4499 - Fax: 636-479-3399

Material Test Report

ENERGY INDUSTRIES OF OHIO

Purchase Order Number PPPL-FP-LTS-2

Pattern Number MCWF-C5 Coil

CAF Metal Designation CF8MNMnMod

Material Spec CF8MNMnMOD

Ladle#1 Heat 30441

Analysis performed by Wisconsin Centrifugal

Cert Number 172810-1

Pour Date 8/8/2005

Element	Min	Actual	Max
C	0.04	0.02	0.07
MN*	2.3	2.2	2.8
SI	0.0	0.3	0.7
CR	18.0	18.2	18.5
NI	13.0	13.5	13.5
MO	2.1	2.4	2.5
P	0.0	0.025	0.035
S	0.0	0.010	0.025
N	0.24	0.25	0.28

* See Corrective Action Number 1323.

Respectfully Submitted,
Charles A. Ruud
Quality Assurance Manager



2 A

Carondelet Division

8600 Commercial Blvd. - Pevely, MO 63070 USA
Phone: 636-479-4499 - Fax: 636-479-3399

Material Test Report

ENERGY INDUSTRIES OF OHIO

Purchase Order Number PPPL-FP-LTS-2

Pattern Number MCWF-C5 Coil

CAF Metal Designation CF8MNMnMod

Material Spec CF8MNMnMOD

Ladle#2 Heat 30442

Analysis performed by Wisconsin Centrifugal

Cert Number 172810-1

Pour Date 8/8/2005

Element	Min	Actual	Max
C	0.04	0.05	0.07
MN*	2.3	1.8	2.8
SI	0.0	0.4	0.7
CR	18.0	18.2	18.5
NI	13.0	13.4	13.5
MO	2.1	2.5	2.5
P	0.0	0.034	0.035
S	0.0	0.018	0.025
N	0.24	0.23	0.28

* See Corrective Action Number 1323.

Respectfully Submitted,
Charles A. Ruud
Quality Assurance Manager



3A

Carondelet Division

8600 Commercial Blvd. - Pevely, MO 63070 USA
Phone: 636-479-4499 - Fax: 636-479-3399

Material Test Report

ENERGY INDUSTRIES OF OHIO

Purchase Order Number PPPL-FP-LTS-2

Cert Number 172810-1

Pattern Number MCWF-C5 Coil

Pour Date 8/8/2005

CAF Metal Designation CF8MNMnMod

Material Spec CF8MNMnMOD

Ladle#3 Heat 30445

Analysis performed by Wisconsin Centrifugal

Element	Min	Actual	Max
C	0.04	0.04	0.07
MN*	2.3	2.0	2.8
SI	0.0	0.3	0.7
CR	18.0	18.3	18.5
NI	13.0	13.3	13.5
MO	2.1	2.4	2.5
P	0.0	0.031	0.035
S	0.0	0.018	0.025
N	0.24	0.24	0.28

* See Corrective Action Number 1323.

Respectfully Submitted,
Charles A. Ruud
Quality Assurance Manager



4.17

Carondelet Division

8600 Commercial Blvd. - Pevely, MO 63070 USA
Phone: 636-479-4499 - Fax: 636-479-3399

Material Test Report

ENERGY INDUSTRIES OF OHIO

Purchase Order Number PPPL-FP-LTS-2

Cert Number 172810-1

Pattern Number MCWF-C5

Pour Date 8/8/2005

CAF Metal Designation CF8MNMnMod

Material Spec CF8MNMnMOD

Weighted average of 3 heats - 30441(39%),30442(21%),30445(40%) Total Weight 31732 lbs.

Analysis performed by Wisconsin Centrifugal

Element	Min	Actual	Max
C	0.04	0.04	0.07
MN*	2.3	2.0	2.8
SI	0.0	0.3	0.7
CR	18.0	18.2	18.5
NI	13.0	13.4	13.5
MO	2.1	2.4	2.5
P	0.0	0.030	0.035
S	0.0	0.015	0.025
N	0.24	0.24	0.28

* See Corrective Action Number 1323.

Respectfully Submitted,
Charles A. Ruud
Quality Assurance Manager



1B

Carondelet Division

8600 Commercial Blvd. - Pevely, MO 63070 USA
Phone: 636-479-4499 - Fax: 636-479-3399

Material Test Report

ENERGY INDUSTRIES OF OHIO

Purchase Order Number PPPL-FP-LTS-2

Pattern Number MCWF-C5 Coil

CAF Metal Designation CF8MNMnMod

Material Spec CF8MNMnMOD

Ladle#1 Heat 30441

Retest after preventive maintenance

Cert Number 172810-1

Pour Date 8/8/2005

Element	Min	Actual	Max
MN	2.3	2.3	2.8
SI	0.0	0.3	0.7
CR	18.0	18.3	18.5
NI	13.0	13.4	13.5
MO	2.1	2.4	2.5
P	0.0	0.029	0.035
S	0.0	0.012	0.025

C & N not analyzed by spectrometer on retest.

Respectfully Submitted,
Charles A. Ruud
Quality Assurance Manager

Superior Quality Engineered Metal Products

www.MetalTekInt.Com



2 B

Carondelet Division

8600 Commercial Blvd. - Pevely, MO 63070 USA
Phone: 636-479-4499 - Fax: 636-479-3399

Material Test Report

ENERGY INDUSTRIES OF OHIO

Purchase Order Number PPPL-FP-LTS-2

Pattern Number MCWF-C5 Coil

CAF Metal Designation CF8MNMnMod

Material Spec CF8MNMnMOD

Ladle#2 Heat 30442

Retest after preventive maintenance

Cert Number 172810-1

Pour Date 8/8/2005

Element	Min	Actual	Max
MN*	2.3	1.8	2.8
SI	0.0	0.4	0.7
CR	18.0	18.3	18.5
NI	13.0	13.3	13.5
MO	2.1	2.5	2.5
P	0.0	0.034	0.035
S	0.0	0.012	0.025

- See Corrective Action Number 1323.
C & N not analyzed by spectrometer on retest.

Respectfully Submitted,
Charles A. Ruud
Quality Assurance Manager

3B



Carondelet Division

8600 Commercial Blvd. - Pevely, MO 63070 USA
Phone: 636-479-4499 - Fax: 636-479-3399

Material Test Report

ENERGY INDUSTRIES OF OHIO

Purchase Order Number PPPL-FP-LTS-2

Pattern Number MCWF-C5 Coil

CAF Metal Designation CF8MNMnMod

Material Spec CF8MNMnMOD

Ladle#3 Heat 30445

Retest after preventive maintenance

Cert Number 172810-1

Pour Date 8/8/2005

Element	Min	Actual	Max
MN*	2.3	2.0	2.8
SI	0.0	0.3	0.7
CR	18.0	18.4	18.5
NI	13.0	13.3	13.5
MO	2.1	2.4	2.5
P	0.0	0.033	0.035
S	0.0	0.012	0.025

* See Corrective Action Number 1323.

C & N not analyzed by spectrometer on retest.

Respectfully Submitted,
Charles A. Ruud
Quality Assurance Manager

Superior Quality Engineered Metal Products

www.MetalTekInt.Com



HB

Carondelet Division

8600 Commercial Blvd. - Pevely, MO 63070 USA
Phone: 636-479-4499 - Fax: 636-479-3399

Material Test Report

ENERGY INDUSTRIES OF OHIO

Purchase Order Number PPPL-FP-LTS-2

Cert Number 172810-1

Pattern Number MCWF-C5

Pour Date 8/8/2005

CAF Metal Designation CF8MNMnMod

Material Spec CF8MNMnMOD

Weighted average of 3 heats - 30441(39%),30442(21%),30445(40%) Total Weight 31732 lbs.

Retest after preventive maintenance

Element	Min	Actual	Max
MN*	2.3	2.1	2.8
SI	0.0	0.3	0.7
CR	18.0	18.3	18.5
NI	13.0	13.3	13.5
MO	2.1	2.4	2.5
P	0.0	0.032	0.035
S	0.0	0.012	0.025

* See Corrective Action Number 1323.

C & N not analyzed by spectrometer on retest.

Respectfully Submitted,
Charles A. Ruud
Quality Assurance Manager



Carondelet Division

8600 Commercial Blvd. - Pevely, MO 63070 USA
Phone: 636-479-4499 - Fax: 636-479-3399

Material Test Report

ENERGY INDUSTRIES OF OHIO

Purchase Order Number PPPL-FP-LTS-2 Heat Number 29198 Pour Date 4/28/2005
Pattern Number SE-141-073 COIL C SHIM (-3 thru -6 Parts) Cert Number S73220-2 and
SE-141-033 COIL A SHIM (-1 thru -6 Parts) Cert Number S76220-1
CAF Metal Designation CF8MNMnMod
Material Spec CF8MNMN MOD

Revised 9/24/05

Element	Min	Actual	Max
C	0.040	0.070	0.070
CR	18.000	18.100	18.500
MN	2.300	2.970	2.800
MO	2.100	2.450	2.500
N	0.240	0.255	0.280
NI	13.000	13.120	13.500
P*	0.000	0.013	0.035
S*	0.000	0.010	0.025
SI	0.000	0.700	0.700

MN & SI previously reported on CA 1308 and were accepted.

*P & S taken from test from heat parts were poured from and analyzed by wet chemistry, ASTM E1019-03 for sulfur and Gravimetric for phosphorous.

This report covers the eleven castings poured from heat 29198. Only parts listed above however will be shipped for this order. Each casting has a unique number stamped in the part adjacent to the pattern number to differentiate the part and subsequent reporting that will be traced to the casting.

Specification limits have been updated to latest specification.

Respectfully Submitted,
Charles A. Ruud
Quality Assurance Manager

Superior Quality Engineered Metal Products

www.MetalTekInt.Com

045

ER316 MNN F
**LINCOLN®
ELECTRIC**

PRODUCT CONFORMANCE REPORT

Product	LNM 4455	Size(s) mm	1,2
Class.	EN 12072-99: G 20 16 3 Mn L	Lot/Batch	3018926/78309
		Item No.	692129
Customer	CK SUPPLY Contact Ernie Simpson Eureka (MISSOURI) 63025 UNITED STATES	Quantity	450,0 KG
		Customer ref.	P.O.: SL 057549
		LSW Order No.	SD424496

Chemical analysis (%)										EN10204 3.1B
C	Si	Mn	P	S	Cr	Ni	Mo	Cu	N	
0,02	0,4	7,3	0,019	0,001	20,1	16,3	2,9	0,1	0,200	

Mechanical tests, all weld metal	EN10204
----------------------------------	---------

Additional information Other tests	EN10204
---------------------------------------	---------

Remarks

The product identified above has been manufactured, tested and supplied in compliance with a Quality Assurance Programme that fulfils the requirements of EN 29000/ ISO 9000/BS 5750 or similar standard.
We herewith certify that the product complies with the above-mentioned standards.
Certified ISO 9001:2000.

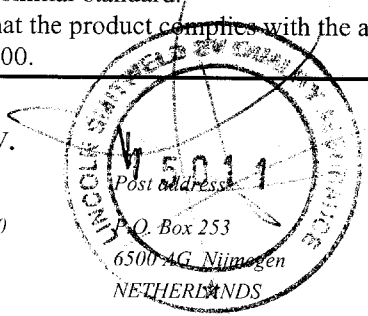

Company	Issued by	Function	Date	Cert.No.
Lincoln Smitweld B.V.	P. van Etteger	QS Manager	10/02/2005	3018926/7830
Registered Office	Telephone:	Fax:		
Nieuwe Dukenburgseweg 20	31 24 3522911	31 24 3522200		
6534 18 NIJMEGEN				



10

2810 Clark Avenue • St. Louis, MO 63103-2574 • (314) 531-8080 • FAX (314) 531-8085
 Chemical, Metallurgical, Mechanical, Nondestructive, Environmental Testing, Analyses and Field Service.

METALTEK INTERNATIONAL
 8600 Commercial Blvd.
 Pevely, MO 63070

August 8, 2005
 Lab No. 05P-2334
 P.O. No. 21324
 Page 1 of 3

Attention: **CHUCK RUUD**

REPORT OF MECHANICAL TESTS

SAMPLE ID: 1) STOCK# LNM 4455, LINCOLN LOT 3018926/78309
 2) STOCK# LNM 4455, LINCOLN LOT 3017006/72262
 3) STOCK# LNM 4455, LINCOLN LOT 3012668/82743
 4) STOCK# B316NF METRODE, W021735

Sample ID	Original Area Sq. Inches	Reduced Area Sq. Inches	Reduction in Area %	Modules of Elasticity	Yield Strength PSI	Tensile Strength PSI	Elongation (2.0" Gage Length)	
							in.	%
1	0.1385	0.0897	54.3	24.5 Msi	56900	93900	0.84	42.0
2	0.1886	0.0935	50.4	24.9 Msi	54900	92100	0.85	42.5
3	0.1909	0.0951	50.2	22.6 Msi	57400	93700	0.83	41.5
4	0.1901	0.0962	49.4	23.0 Msi	54800	88200	0.75	37.5

Round, reduced section all weld tensiles

Yield taken at .2% offset

Tested in accordance with ASTM A 370-03a

Identification of tested specimens provided by the client.

Karl Schmitz, Director
 Materials Testing

KS/tiv



Certificate No. 0397-01
 Certificate No. 0397-02

19

AN OFFICIAL COPY OF TEST REPORT WILL BE PROVIDED BY THIS LABORATORY ON REQUEST.
 NOT OFFICIAL WITHOUT THE RAISED SEAL OF ST. LOUIS TESTING LABORATORIES, INC.
 SEE REVERSE FOR CONDITIONS.

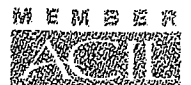



10

2810 Clark Avenue • St. Louis, MO 63103-2574 • (314) 531-8080 • FAX (314) 531-8085
 Chemical, Metallurgical, Mechanical, Nondestructive, Environmental Testing, Analyses and Field Service.

METALTEK INTERNATIONAL
 8600 Commercial Blvd.
 Pevely, MO 63070

August 8, 2005
 Lab No. 05P-2334
 P.O. No. 21324
 Page 2 of 3

Attention: Chuck Ruud

REPORT OF CHARPY IMPACT TEST

MATERIAL (SAMPLE ID): STOCK# LNM 4455, LINCOLN LOT 3018926/78309
 STOCK# LNM 4455, LINCOLN LOT 3017006/72262

SPECIFICATION: ASTM A 370-03a
SPECIMEN TYPE: "A" Vee Notch
SPECIMEN SIZE: 10 mm x 10 mm (All Weld)
TEMPERATURE OF TEST: 293°K

REQUIREMENTS:

ALL WELD	FOOT LBS.	LATERAL EXPANSION	% SHEAR
78309-7	97	0.074	50
78309-8	96	0.076	50
78309-9	108	0.075	50
Average	100	0.075	50
ALL WELD	FOOT LBS.	LATERAL EXPANSION	% SHEAR
72262-7	126	0.098	50
72262-8	102	0.080	50
72262-9	123	0.087	50
Average	117	0.088	50

Identification of tested specimen provided by client.

KS/tv

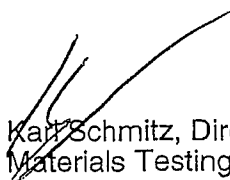
 Karl Schmitz, Director
 Materials Testing



Certificate No. 0397-01
 Certificate No. 0397-02

AN OFFICIAL COPY OF TEST REPORT WILL BE PROVIDED BY THIS LABORATORY ON REQUEST.
 NOT OFFICIAL WITHOUT THE RAISED SEAL OF ST. LOUIS TESTING LABORATORIES, INC.
 SEE REVERSE FOR CONDITIONS.

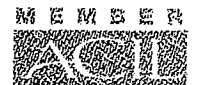

2810 Clark Avenue • St. Louis, MO 63103-2574 • (314) 531-8080 • FAX (314) 531-8085
 Chemical, Metallurgical, Mechanical, Nondestructive, Environmental Testing, Analyses and Field Service.

METALTEK INTERNATIONAL
 8600 Commercial Blvd.
 Pevely, MO. 63070

August 8, 2005
 Lab No. 05P-2334
 P.O. No. 21324
 Page 3 of 3

Attention: Chuck Ruud

REPORT OF CHARPY IMPACT TEST

MATERIAL (SAMPLE ID): STOCK# LNM 4455, LINCOLN LOT 3012668/82743
 STOCK# B316NF METRODE, W021735

SPECIFICATION: ASTM A 370-03a

SPECIMEN TYPE: "A" Vee Notch

SPECIMEN SIZE: 10 mm x 10 mm (All Weld)

TEMPERATURE OF TEST: 293°K

REQUIREMENTS:

ALL WELD	FOOT LBS.	LATERAL EXPANSION	% SHEAR
82743-7	100	0.082	50
82743-8	99	0.076	50
82743-9	94	0.072	50
Average	98	0.077	50
ALL WELD	FOOT LBS.	LATERAL EXPANSION	% SHEAR
W021735-7	102	0.101	50
W021735-8	88	0.073	50
W021735-9	88	0.080	50
Average	93	0.085	50

Identification of tested specimen provided by client.

 Karl Schmitz, Director
 Materials Testing

KS/tlv



Certificate No. 0397-01
 Certificate No. 0397-02

21

AN OFFICIAL COPY OF TEST REPORT WILL BE PROVIDED BY THIS LABORATORY ON REQUEST.
 NOT OFFICIAL WITHOUT THE RAISED SEAL OF ST. LOUIS TESTING LABORATORIES, INC.
 SEE REVERSE FOR CONDITIONS.

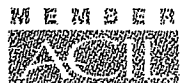

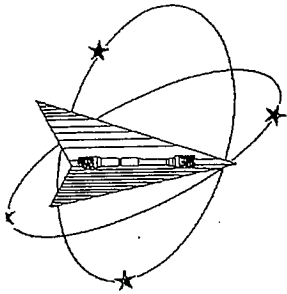

Westmoreland Mechanical Testing & Research, Inc.

P.O. Box 388

Westmoreland Drive

Youngstown, Pa. 15696-0388 U.S.A.

Telephone: 724-537-3131 Fax: 724-537-3151

Website: www.wmtr.com

WMT&R is a technical leader in the material testing industry.



621-01 & 621-02



September 13, 2005

CERTIFICATION

MetalTek International
The Carondelet Division
8600 Commercial Blvd.
I-55 Industrial Park
Pevely, MO 63070-1528

Attention: Jim Galaske

Subject: All processes, performed upon the material as received, were conducted at WMT&R, Inc. in accordance with the WMT&R Quality Assurance Manual, Rev. 9, dated 4/1/2000.
The following tests were performed on this order: IMPACT and TENSILE

WMT&R Report No. 5-34328
P.O. No. 19386 Rel No.18
Requisition No. 4934

TENSILE RESULTS: ASTM E21-03a

Requirements: UTS ksi (Min 95\Max ---) 0.2% YS ksi (Min 72\Max ---) 4D Elong. % (Min 32\Max ---) Modulus Msi (Min 21\Max ---)

SOAK TIME: 5 Minutes

SPEED OF TESTING: 0.0030 in./in./min., 0.0500 in./min./in.

MATERIAL: 316 S/S

DISPOSITION: Acceptable

Reference	Lot No. Batch No. Specimen ID	TestLog Number	Temp. °F	UTS ksi	0.2% YS ksi	Elong %	RA %	Modulus Msi	Ult. Load lbf	0.2% YLD. lbf
Lincoln LNM4455	3018926 78309 Tensile	C43938	-320	182.1	128.2	34	24	27.0	17560	12360

AIUR: A=ACCEPTABLE, U=UNACCEPTABLE, R=REPORT

DISPOSITION: Acceptable

Reference	Lot No. Batch No. Specimen ID	TestLog Number	Orig. Dia. (in.)	Final Dia. (in.)	4D Orig GL (in.)	4D Final GL (in.)	Orig. Area (sq. in.)	Machine Number	AIUR
Lincoln LNM4455	3018926 78309 Tensile	C43938	0.3504	0.3048	1.40	1.87	0.09643131	M9	A

AIUR: A=ACCEPTABLE, U=UNACCEPTABLE, R=REPORT

Requirements supplied by MetalTek International.

Rby E. Starr
Technical Services Manager

9-13-05
September 13, 2005

KNOWINGLY OR WILLFULLY FALSIFYING OR CONCEALING A MATERIAL FACT ON THIS FORM OR MAKING FALSE, FICTITIOUS OR FRAUDULENT STATEMENTS OR REPRESENTATIONS HEREIN COULD CONSTITUTE A FELONY PUNISHABLE UNDER FEDERAL STATUTES. THIS CERTIFICATE OF REPORT SHALL NOT BE REPRODUCED EXCEPT IN FULL, WITHOUT THE WRITTEN APPROVAL OF WMTR, INC.

Testing Specialists for Aerospace, Automotive, and Material Testing Fields
Locations in Youngstown, PA U.S.A. ~ Tel. (724) 537-3131 and
Banbury U.K. ~ Tel. +44 (0) 1295 261211

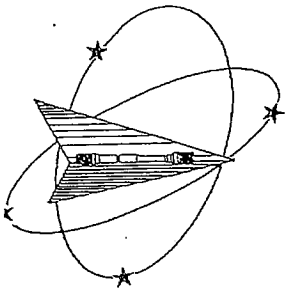

Westmoreland Mechanical Testing & Research, Inc.

P.O. Box 388

Westmoreland Drive

Youngstown, Pa. 15696-0388 U.S.A.

Telephone: 724-537-3131 Fax: 724-537-3151

Website: www.wmtr.com

WMT&R is a technical leader in the material testing industry.



621-01 & 621-02



September 13, 2005

CERTIFICATION

MetalTek International
The Carondelet Division
8600 Commercial Blvd.
I-55 Industrial Park
Pevely, MO 63070-1528

WMT&R Report No. 5-34328

P.O. No. 19386 Rel No.18

Requisition No. 4934

Attention: Jim Galaske

Subject: All processes, performed upon the material as received, were conducted at WMT&R, Inc. in accordance with the WMT&R Quality Assurance Manual, Rev. 9, dated 4/1/2000.

The following tests were performed on this order: IMPACT and TENSILE

IMPACT RESULTS: ASTM E23-02

REQUIREMENTS: Energy (Min 35\Max →)

MATERIAL: Lincoln LNM4455

SAMPLE TYPE: Charpy V-Notch

DISPOSITION: Acceptable

Reference	Lot No. Batch No. Specimen ID	TestLog Number	Sample Size	Temp. °F	Energy ft-lbs	Mils Lat Exp	% Shear Fracture	AIUR
Lincoln LNM4455	3018926 78309 Cvn-1	C43939	Standard	-320	56	18	40	Acceptable
Lincoln LNM4455	3018926 78309 Cvn-2	C43940	Standard	-320	52	18	40	Acceptable
Lincoln LNM4455	3018926 78309 Cvn-3	C43941	Standard	-320	53	12	40	Acceptable

Requirements supplied by MetalTek International.



Roy E. Star, Matt Wojcik
Technical Services Manager / Tensile Supervisor

9-13-05

September 13, 2005

KNOWINGLY OR WILLFULLY FALSIFYING OR CONCEALING A MATERIAL FACT ON THIS FORM OR MAKING FALSE, FICTITIOUS OR FRAUDULENT STATEMENTS OR REPRESENTATIONS HEREIN COULD CONSTITUTE A FELONY PUNISHABLE UNDER FEDERAL STATUTES. THIS CERTIFICATE OF REPORT SHALL NOT BE REPRODUCED EXCEPT IN FULL, WITHOUT THE WRITTEN APPROVAL OF WMT&R, INC.

Testing Specialists for Aerospace, Automotive, and Material Testing Fields
Locations in Youngstown, PA U.S.A. ~ Tel. (724) 537-3131 and
Banbury U.K. ~ Tel. +44 (0) 1295 261211

9A

PRODUCT CONFORMANCE REPORT



Product	ENM 4455	Size(s) mm	1,2
Class	EN 12072-99: G 20 16 3 Mn L	Lot/Batch	3018513/78308
		Item No.	692129
Customer	EUROWELD MOORESVILLE N.C. 28117 UNITED STATES	Quantity	105,0 KG
		Customer ref.	P.O. 05 - 46
		LSW Order No.	SD427896

Chemical analysis (%) EN10204 2.2

C	Si	Mn	P	S	Cr	Ni	Mo	Cu	N
0,01	0,5	7,3	0,015	0,001	20,3	15,4	2,9	0,1	0,19

Mechanical tests, all weld metal EN10204 2.2

Tensile testing					Impact testing		
Cond.	Temp.	Rp0.2	Rm	A5	Cond.	Temp.1	Av1
	°C	N/mm2	N/mm2	%		°C	J
AW	RT	407	623	41	AW	-196	67

Additional information EN10204 2.2

Other tests

Remarks
Impact testing (individual values): 70J - 65J - 67J

The product identified above has been manufactured, tested and supplied in compliance with a Quality Assurance Programme that fulfils the requirements of EN 29000/ ISO 9000/BS 5750 or similar standard.
We herewith certify that the product complies with the above mentioned standards.
Certified ISO 9001:2000.

Company	Issued by	Function	Date	Cert.No.
Lincoln Smitweld B.V.	P. Nagels	QA Administrator	22/03/2005	3018513/7830
Registered Office	Telephone	Fax:		
Nijmegen Dukenburgseweg 20	31 24 3522911	31 24 3522200		
6594 AD NIJMEGEN	Post address			
	P.O. Box 253			
	6500 AG Nijmegen			

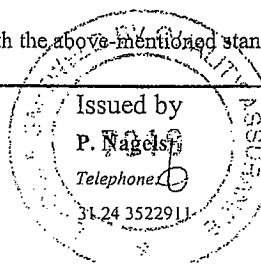

2810 Clark Avenue • St. Louis, MO 63103-2574 • (314) 531-8080 • FAX (314) 531-8085
 Chemical, Metallurgical, Mechanical, Nondestructive, Environmental Testing, Analyses and Field Service.

METALTEK INTERNATIONAL
 8600 Commercial Blvd.
 Pevely, MO 63070

August 16, 2005
 Lab No. 05P-2532
 P.O. No. 21324
 Page 1 of 2

Attention: Chuck Ruud

REPORT OF CHARPY IMPACT TEST

MATERIAL (SAMPLE ID): LNM 4455, LINCOLN LOT 3018513/78308
SPECIFICATION: ASTM A 370-03a
SPECIMEN TYPE: "A" Vee Notch
SPECIMEN SIZE: 10 mm x 10 mm
TEMPERATURE OF TEST: 293°K

BASE METAL	FOOT LBS.	LATERAL EXPANSION	% SHEAR
LNM4455-7	104	0.085	100
LNM4455-8	106	0.093	100
LNM4455-9	99	0.084	100
Average	103	0.087	100

Identification of tested specimen provided by client.

 Karl Schmitz, Director
 Materials Testing

KS/tlv



Certificate No. 0397-01
 Certificate No. 0397-02

AN OFFICIAL COPY OF TEST REPORT WILL BE PROVIDED BY THIS LABORATORY ON REQUEST.
 NOT OFFICIAL WITHOUT THE RAISED SEAL OF ST. LOUIS TESTING LABORATORIES, INC.
 SEE REVERSE FOR CONDITIONS.



2810 Clark Avenue • St. Louis, MO 63103-2574 • (314) 531-8080 • FAX (314) 531-8085
 Chemical, Metallurgical, Mechanical, Nondestructive, Environmental Testing, Analyses and Field Service.

METALTEK INTERNATIONAL
 8600 Commercial Blvd.
 Pevely, MO 63070

August 16, 2005
 Lab No. 05P-2532
 P.O. No. 21324
 Page 2 of 2

Attention: CHUCK RUUD

REPORT OF MECHANICAL TESTS

SAMPLE ID: LNM 4455, LINCOLN LOT 3018513/78308

Sample ID	Original Area Sq. Inches	Reduced Area Sq. Inches	Reduction in Area %	Yield Strength PSI	Tensile Strength PSI	Elongation (2.0" Gage Length)		Modules of Elasticity
						in.	%	
LNM4455	0.1932	0.0866	55.2	65200	95200	0.76	38.0	23.4

Round, reduced section tensiles

Yield taken at .2% offset

Tested in accordance with ASTM A 370-03a

Identification of tested specimens provided by the client.

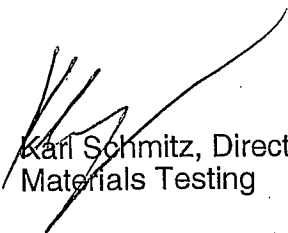
 Karl Schmitz, Director
 Materials Testing

KS/tlv



Certificate No. 0397-01
 Certificate No. 0397-02

AN OFFICIAL COPY OF TEST REPORT WILL BE PROVIDED BY THIS LABORATORY ON REQUEST.
 NOT OFFICIAL WITHOUT THE RAISED SEAL OF ST. LOUIS TESTING LABORATORIES, INC.
 SEE REVERSE FOR CONDITIONS.



11A

..#302222 PAGE: 2/2

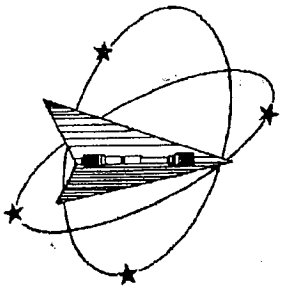

Westmoreland Mechanical Testing & Research, Inc.
 P.O. Box 388
 Westmoreland Drive
 Youngstown, Pa. 15696-0388 U.S.A.
 Telephone: 724-537-3131 Fax: 724-537-3151
 Website: www.wmtr.com
 WMT&R is a technical leader in the material testing industry.



Section 1 of 1

WMT&R Report No. 5-35979
Requisition No. 4972

October 18, 2005

CERTIFICATION

MetalTek International
 The Carondelet Division
 8600 Commercial Blvd.
 I-55 Industrial Park
 Pevely, MO 63070-1528

Attention: Jim Galaske

Subject: All processes, performed upon the material as received, were conducted at WMT&R, Inc. in accordance with the WMT&R Quality Assurance Manual, Rev. 9, dated 4/1/2000.
 The following tests were performed on this order: TENSILE

TENSILE RESULTS: ASTM E21-03a

SOAK TIME: 5 Minutes

SPEED OF TESTING: 0.0030 in./in./min., 0.0500 in./min./in.

MATERIAL: METALTEK CF8MNMNMOD

DISPOSITION: Report

Specimen ID	TestLog Number	Temp. °F	UTS ksi	0.2% YS ksi	Elong %	RA %	Modulus Msi	Ult. Load lbf	0.2% YLD. lbf	Orig. Dia. (in.)	Final Dia. (in.)	4D Orig GL (in.)	4D Final GL (in.)	Orig. Area (sq. in.)	Machine Number	AIUR
3018513/78308	C54936	-320	184.9	123.7	33	33	32.8	18470	12350	0.3566	0.2926	1.40	1.86	0.09987403	M9	R

AIUR: A=ACCEPTABLE, U=UNACCEPTABLE, R=REPORT

FAX NO: 5377001

14:24 OCT 18, 2005

 Roy E. Starnati Wojton
 Technical Services Manager Tensile Supervisor

10-18-05

October 18, 2005

KNOWINGLY OR WILLFULLY FALSIFYING OR CONCEALING A MATERIAL FACT ON THIS FORM OR MAKING FALSE, FICTITIOUS OR FRAUDULENT STATEMENTS OR REPRESENTATIONS HEREIN COULD CONSTITUTE A FELONY PUNISHABLE UNDER FEDERAL STATUTES. THIS CERTIFICATE OR REPORT SHALL NOT BE REPRODUCED EXCEPT IN FULL, WITHOUT THE WRITTEN APPROVAL OF WMT&R, INC.

Testing Specialists for Aerospace, Automotive, and Material Testing Fields
 Locations in Youngstown, PA U.S.A. ~ Tel. (724) 537-3131 and
 Banbury U.K. ~ Tel. +44 (0) 1295 261211

11A



2810 Clark Avenue • St. Louis, MO 63103-2574 • (314) 531-8080 • FAX (314) 531-8085
Chemical, Metallurgical, Mechanical, Nondestructive, Environmental Testing, Analyses and Field Service.

METALTEK INTERNATIONAL
8600 Commercial Blvd.
Pevely, MO 63070

October 5, 2005
Lab No. 05P-3096
P.O. No. 21324
Page 1 of 1

Attention: Chuck Ruud

REPORT OF CHARPY IMPACT TEST

MATERIAL (SAMPLE ID): WELD PLATE- 3018513 / 78308
SPECIFICATION: ASTM A 370-03a
SPECIMEN TYPE: "A" Vee Notch
SPECIMEN SIZE: 10 mm x 10 mm
TEMPERATURE OF TEST: -320°F
REQUIREMENTS: minimum 35 ft / lbs.

BASE METAL	FOOT LBS.	LATERAL EXPANSION	% SHEAR
3018513/78308-1	48	0.033	50
3018513/78308-2	65	0.045	50
3018513/78308-3	48	0.033	50
Average	54	0.037	50

Identification of tested specimen provided by client.

KS/tlv



Karl Schmitz, Director
Materials Testing



Certificate No. 0397-01
Certificate No. 0397-02

AN OFFICIAL COPY OF TEST REPORT WILL BE PROVIDED BY THIS LABORATORY ON REQUEST.
NOT OFFICIAL WITHOUT THE RAISED SEAL OF ST. LOUIS TESTING LABORATORIES, INC.
SEE REVERSE FOR CONDITIONS.

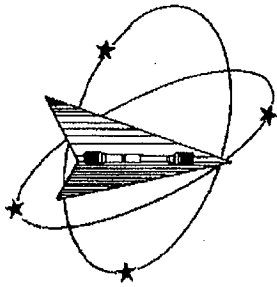



Westmoreland Mechanical Testing & Research, Inc.

P.O. Box 388
Westmoreland Drive
Youngstown, Pa. 15696-0388 U.S.A.
Telephone: 724-537-3131 Fax: 724-537-3151
Website: www.wmtr.com

WMT&R is a technical leader in the material testing industry.



621-01 & 621-02

7A

October 18, 2005

CERTIFICATION

Section 1 of 1

WMT&R Report No. 5-35978
Requisition No. 4972

MetalTek International
The Carondelet Division
8600 Commercial Blvd.
I-55 Industrial Park
Pevely, MO 63070-1528

Corrected Date
November 18, 2005

Test 1

Attention: Jim Galaske

Subject: All processes, performed upon the material as received, were conducted at WMT&R, Inc. in accordance with the WMT&R Quality Assurance Manual, Rev. 9, dated 4/1/2000.
The following tests were performed on this order: TENSILE

TENSILE RESULTS: ASTM E21-05

SOAK TIME: 5 Minutes

SPEED OF TESTING: 0.0030 in./in./min., 0.0500 in./min./in.

MATERIAL: METALTEK CF8MNMNMOD

DISPOSITION: Report

Specimen ID	Test Log Number	Temp. °F	UTS ksi	0.2% YS ksi	Elong %	RA %	Modulus Msi	Ult. Load lbf	0.2% YLD. lbf	Orig. Dia. (in.)	Final Dia. (in.)	4D Orig GL (in.)	4D Final GL (in.)	Orig. Area (sq. in.)	Machine Number	AIUR
C5-Z1	C54933	-320	182.5	112.6	31	28	33.0	18350	11320	0.3578	0.3039	1.40	1.83	0.10054733	M9	R
C5-Z2	C54934	-320	166.1	98.3	52	52	31.8	16740	9903	0.3582	0.2471	1.40	2.13	0.10077227	M9	R
C5-Z3	C54935	-320	163.7	95.5	59	58	28.0	16490	9622	0.3581	0.2316	1.40	2.23	0.10071601	M9	R

AIUR: A=ACCEPTABLE, U=UNACCEPTABLE, R=REPORT

Matt Wojton
Roy E. Starin
Technical Services Manager / Tensile Supervisor

11/18/05
November 18, 2005

KNOWINGLY OR WILLFULLY FALSIFYING OR CONCEALING A MATERIAL FACT ON THIS FORM OR MAKING FALSE, FICTITIOUS OR FRAUDULENT STATEMENTS OR REPRESENTATIONS HEREIN COULD CONSTITUTE A FELONY PUNISHABLE UNDER FEDERAL STATUTES. THIS CERTIFICATE OR REPORT SHALL NOT BE REPRODUCED EXCEPT IN FULL AND WITHOUT THE WRITTEN APPROVAL OF WMT&R, INC.

Testing Specialists for Aerospace, Automotive, and Material Testing Fields
Locations in Youngstown, PA U.S.A. ~ Tel. (724) 537-3131 and
Banbury U.K. ~ Tel. +44 (0) 1295 261211

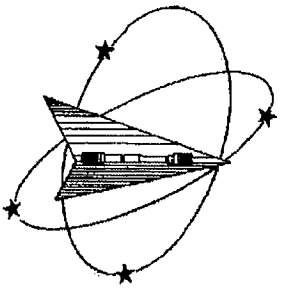

Westmoreland Mechanical Testing & Research, Inc.
 P.O. Box 388
 Westmoreland Drive
 Youngstown, Pa. 15696-0388 U.S.A.
 Telephone: 724-537-3131 Fax: 724-537-3151
 Website: www.wmtr.com
 WMT&R is a technical leader in the material testing industry.

7B



621-01 & 621-02

November 21, 2005

CERTIFICATION

Section 1 of 2

MetalTek International
 The Carondelet Division
 8600 Commercial Blvd.
 I-55 Industrial Park
 Pevely, MO 63070-1528

WMT&R Report No. 5-39106
 P.O. No. 19386
 Requisition No. 4985

Test 2

Attention: Jim Galaske

Subject: All processes, performed upon the material as received, were conducted at WMT&R, Inc. in accordance with the WMT&R Quality Assurance Manual, Rev. 9, dated 4/1/2000.
 The following tests were performed on this order: TENSILE

TENSILE RESULTS: ASTM E21-05

Requirements: UTS ksi (Min 95\Max ---) 0.2% YS ksi (Min 72\Max ---) 4D Elong. % (Min 32\Max ---) Modulus Msi (Min 21\Max ---)

SOAK TIME: 5 Minutes

SPEED OF TESTING: 0.003 in./in./min., 0.05 in./min./in.

MATERIAL: Metaltek CF8MNMnMOD

DISPOSITION: Acceptable

Specimen ID	Test Log Number	Temp. °F	UTS ksi	0.2% YS ksi	Elong %	RA %	Modulus Msi	Ult. Load lbf	0.2% YLD. lbf	Orig. Dia. (in.)	Final Dia. (in.)	4D Orig GL (in.)	4D Final GL (in.)	Orig. Area (sq. in.)	Machine Number	AI\UR
C5-22	C67051	-320	172.3	102.5	41	32	28.2	16630	9893	0.3506	0.2885	1.40	1.98	0.09654142	M9	A
C5-23	C67052	-320	163.5	95.0	64	67	25.9	15830	9200	0.3511	0.2006	1.40	2.30	0.09681698	M9	A

AI\UR: A=ACCEPTABLE, U=UNACCEPTABLE, R=REPORT

Roy E. Starr\Matt Wojton
 Technical Services Manager\Tensile Supervisor

November 21, 2005

KNOWINGLY OR WILLFULLY FALSIFYING OR CONCEALING A MATERIAL FACT ON THIS FORM OR MAKING FALSE, FICTITIOUS OR FRAUDULENT STATEMENTS OR REPRESENTATIONS HEREIN COULD CONSTITUTE A FELONY PUNISHABLE UNDER FEDERAL STATUTES THIS CERTIFICATE OR REPORT SHALL NOT BE REPRODUCED EXCEPT IN FULL AND WITHOUT THE WRITTEN APPROVAL OF WMT&R, INC.

Testing Specialists for Aerospace, Automotive, and Material Testing Fields
 Locations in Youngstown, PA U.S.A. ~ Tel. (724) 537-3131 and
 Banbury U.K. ~ Tel. +44 (0) 1295 261211

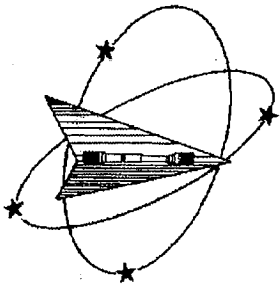

Westmoreland Mechanical Testing & Research, Inc.

P.O. Box 388

Westmoreland Drive

Youngstown, Pa. 15696-0388 U.S.A.

Telephone: 724-537-3131

Fax: 724-537-3151

Website: www.wmtr.com

WMT&R is a technical leader in the material testing industry.

70



621-01 & 621-02



November 21, 2005

CERTIFICATION

Section 2 of 2

MetalTek International

WMT&R Report No. 5-39106

P.O. No. 19386

TENSILE RESULTS: ASTM E21-05

Requirements: UTS ksi (Min 95\Max ---) 0.2% YS ksi (Min 72\Max ---) 4D Elong. % (Min 32\Max ---) Modulus Msi (Min 21\Max ---)

SOAK TIME: 5 Minutes

SPEED OF TESTING: 0.003 in./in./min., 0.05 in./min./in.

MATERIAL: Metaltek CF8MNMnMOD

DISPOSITION: Unacceptable

Specimen ID	Test Log Number	Temp. °F	UTS ksi	0.2% YS ksi	Elong %	RA %	Modulus Msi	Codes	Ult. Load lbf	0.2% YLD lbf	Orig. Dia. (in.)	Final Dia. (in.)	4D Orig. GL (in.)	4D Final GL (in.)	Orig. Area (sq. in.)	Machine Number	AIUR
G5-Z1	Q67050	-320	177.4	111.2	29	28	34.5	D	17120	10730	0.3505	0.2982	1.40	1.81	0.09648636	M9	U

AIUR: A=ACCEPTABLE, U=UNACCEPTABLE, R=REPORT

Requirements provided by MetalTek International

Reference: Tensile Results Reported on WMT&R Report 5-37644 and Hardness, Microstructure Results on WMT&R Report 5-39107

D - Failed outside middle half of gage length.

KNOWINGLY OR WILLFULLY FALSIFYING OR CONCEALING A MATERIAL FACT ON THIS FORM OR MAKING FALSE, FICTITIOUS OR FRAUDULENT STATEMENTS OR REPRESENTATIONS HEREIN COULD CONSTITUTE A FELONY PUNISHABLE UNDER FEDERAL STATUTES. THIS CERTIFICATE OR REPORT SHALL NOT BE REPRODUCED EXCEPT IN FULL WITHOUT THE WRITTEN APPROVAL OF WMT&R, INC.

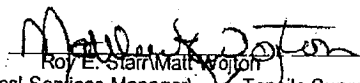
 Roy E. Star
 Technical Services Manager

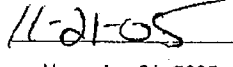
 Matt Wojton
 Tensile Supervisor

November 21, 2005

Testing Specialists for Aerospace, Automotive, and Material Testing Fields
 Locations in Youngstown, PA U.S.A. ~ Tel. (724) 537-3131 and
 Banbury U.K. ~ Tel. +44 (0) 1295 261211

2810 Clark Avenue • St. Louis, MO 63103-2574 • (314) 531-8080 • FAX (314) 531-8085
 Chemical, Metallurgical, Mechanical, Nondestructive, Environmental Testing, Analyses and Field Service.

METALTEK INTERNATIONAL
 8600 Commercial Blvd.
 Pevely, MO 63070

August 18, 2005
 Lab No. 05P-2592
 P.O. No. 21324
 Page 1 of 3

Attention: Chuck Ruud

REPORT OF CHARPY IMPACT TEST

MATERIAL (SAMPLE ID): C5- Z1, Z2, Z3
SPECIFICATION: ASTM A 370-03a
SPECIMEN TYPE: "A" Vee Notch
SPECIMEN SIZE: 10 mm x 10 mm
TEMPERATURE OF TEST: 293°K

BASE METAL	FOOT LBS.	LATERAL EXPANSION	% SHEAR
Z1-7	136	0.083	30
Z1-8	126	0.079	30
Z1-9	128	0.081	30
Average	130	0.081	30
SAMPLE ID	FOOT LBS.	LATERAL EXPANSION	% SHEAR
Z2-7	138	0.080	30
Z2-8	119	0.065	20
Z2-9	137	0.107	40
Average	131	0.084	30
SAMPLE ID	FOOT LBS.	LATERAL EXPANSION	% SHEAR
Z3-7	139	0.099	30
Z3-8	174	0.096	40
Z3-9	156	0.089	40
Average	156	0.095	37

Identification of tested specimen provided by client.

 Karl Schmitz, Director
 Materials Testing

KS/tiv



Certificate No. 0397-02
 Certificate No. 0397-02

AN OFFICIAL COPY OF TEST REPORT WILL BE PROVIDED BY THIS LABORATORY ON REQUEST.
 NOT OFFICIAL WITHOUT THE RAISED SEAL OF ST. LOUIS TESTING LABORATORIES, INC.
 SEE REVERSE FOR CONDITIONS.



2810 Clark Avenue • St. Louis, MO 63103-2574 • (314) 531-8080 • FAX (314) 531-8085
 Chemical, Metallurgical, Mechanical, Nondestructive, Environmental Testing, Analyses and Field Service.

METALTEK INTERNATIONAL
 8600 Commercial Blvd.
 Pevely, MO 63070

August 18, 2005
 Lab No. 05P-2592
 P.O. No. 21324
 Page 2 of 3

Attention: Chuck Ruud

REPORT OF CHARPY IMPACT TEST

MATERIAL (SAMPLE ID): C5- Z1, Z2, Z3
SPECIFICATION: ASTM A 370-03a
SPECIMEN TYPE: "A" Vee Notch
SPECIMEN SIZE: 10 mm x 10 mm
TEMPERATURE OF TEST: 77°K

BASE METAL	FOOT LBS.	LATERAL EXPANSION	% SHEAR
Z1-7	78	0.047	40
Z1-8	82	0.053	40
Z1-9	82	0.050	40
Average	81	0.050	40
SAMPLE ID	FOOT LBS.	LATERAL EXPANSION	% SHEAR
Z2-7	72	0.043	40
Z2-8	75	0.039	40
Z2-9	72	0.043	40
Average	73	0.042	40
SAMPLE ID	FOOT LBS.	LATERAL EXPANSION	% SHEAR
Z3-7	93	0.053	40
Z3-8	86	0.067	50
Z3-9	82	0.065	40
Average	87	0.062	43

Identification of tested specimen provided by client.

 Karl Schmitz, Director
 Materials Testing

KS/tlv



Certificate No. 0397-02
 Certificate No. 0397-02

AN OFFICIAL COPY OF TEST REPORT WILL BE PROVIDED BY THIS LABORATORY ON REQUEST.
 NOT OFFICIAL WITHOUT THE RAISED SEAL OF ST. LOUIS TESTING LABORATORIES, INC.
 SEE REVERSE FOR CONDITIONS.



8

2810 Clark Avenue • St. Louis, MO 63103-2574 • (314) 531-8080 • FAX (314) 531-8085
Chemical, Metallurgical, Mechanical, Nondestructive, Environmental Testing, Analyses and Field Service.

METALTEK INTERNATIONAL
8600 Commercial Blvd.
Pevely, MO 63070

August 18, 2005
Lab No. 05P-2592
P.O. No. 21324
Page 3 of 3

Attention: **CHUCK RUUD**

REPORT OF MECHANICAL TESTS

SAMPLE ID: C5- Z1, Z2, Z3

Sample ID	Original Area Sq. Inches	Reduced Area Sq. Inches	Reduction in Area %	Modulus of Elasticity	Yield Strength PSI	Tensile Strength PSI	Elongation (2.0" Gage Length)	
							in.	%
Z1	0.1963	0.1041	47.0	28.4 Msi	41500	92900	1.11	55.0
Z2	0.1893	0.1012	46.5	27.7 Msi	37700	84400	1.04	52.0
Z3	0.1909	0.1052	44.9	25.9 Msi	37100	83700	1.34	67.0

Round, reduced section tensiles

Yield taken at .2% offset

Tested in accordance with ASTM A 370-03a

Identification of tested specimens provided by the client.

KS/kss

Karl Schmitz, Director
Materials Testing



Certificate No. 0397-02
Certificate No. 0397-02

AN OFFICIAL COPY OF TEST REPORT WILL BE PROVIDED BY THIS LABORATORY ON REQUEST.
NOT OFFICIAL WITHOUT THE RAISED SEAL OF ST. LOUIS TESTING LABORATORIES, INC.
SEE REVERSE FOR CONDITIONS.



C-5 Coil Weld Map – Metal Tek

Map of all major welds exceeding 20% of wall, over 1 inch or over 10² inches

Defect Number	Drawing View	Length (inches)	Width (inches)	Depth (inches)
1	Right	8	7	3
2	Right	23	16	3
3	Right	3	3	2
4	Right	7 ½	5	2
5	Right	24	13	¾
6	Left	9	2	Thru
7	Left	21	4	Thru
8	Left	16	1 ½	¾
9	Left	14	9	1 ¼
10	Left	7	4	Thru
11	Right	7 ½	4	Thru
12	Right	10 ½	1 ½	¾
13	Right	6	4	1 ¼
14	Right	5	1 ¾	1 ½
15	Right	4	4	Thru
16	Right	4	2	Thru
17	Right	6	4	1
18	Right	12	4	Thru
19	Right	18	4	2
20	Right	15	2	2
21	Right	14	3	¾
22	Right	16	6	1
23	Right	5 ¼	4	¾
24	Right	7	4	¼
25	Right	6	4	3
26	Right	9	3	1 ½
27	Right	3	2	1 ½
28	Right	4	5	1
29	Right	4	3	1 ¼
30	Right	6	5 ½	¾
31	Right	10	7	Thru
32	Right	2	2	1
33	Bottom	4	2 ½	2
34	Bottom	5 ½	2	2
35	Bottom	11	4	¾

C-5 Coil Weld Map – Metal Tek

Map of all major welds exceeding 20% of wall, over 1 inch or over 10² inches

Defect Number	Drawing View	Length (inches)	Width (inches)	Depth (inches)
36	Back	7	3	1 ½
37	Back	4	3	2
38	Back	16	4	1
39	Back	9	4 ¼	¾
40	Back	5	5	¾
41	Back	5	1 ½	1 ½
42	Back	22 ½	1	¾
43	Back	5	3	1
44	Back	7	3	1
45	Front	4	2	Thru
46	Front	7 ½	3	2
47	Left	31	12	1
48	Left	32 ¾	6	¾
49	Left	18	1	¼
50	Left	14	7	1
51	Left	17	1	Thru
52	Left	7	5 ½	¾
53	Left	21	6	3
54	Left	9	1 ½	¼
55	Left	13	4	Thru
56	Left	9	2 ½	1 ½
57	Left	6	6	Thru
58	Left	2	2	2
59	Left	10	6	1
60	Left	22	8	1
61	Left	24	1 ½	¾
62	Left	28	3	2
63	Left	15	4 ½	1
64	Left	21	7	1
65	Left	3	2 ½	2 ½
66	Left	13	5	Thru
67	Left	4	4	2 ½
68	Left	8	2	1 ½
6	Left	4	4	2
70	Left	15	1	½
71	Left	4	2 ½	3
72	Left	9	4 ½	½

C-5 Coil Weld Map – Metal Tek

Map of all major welds exceeding 20% of wall, over 1 inch or over 10² inches

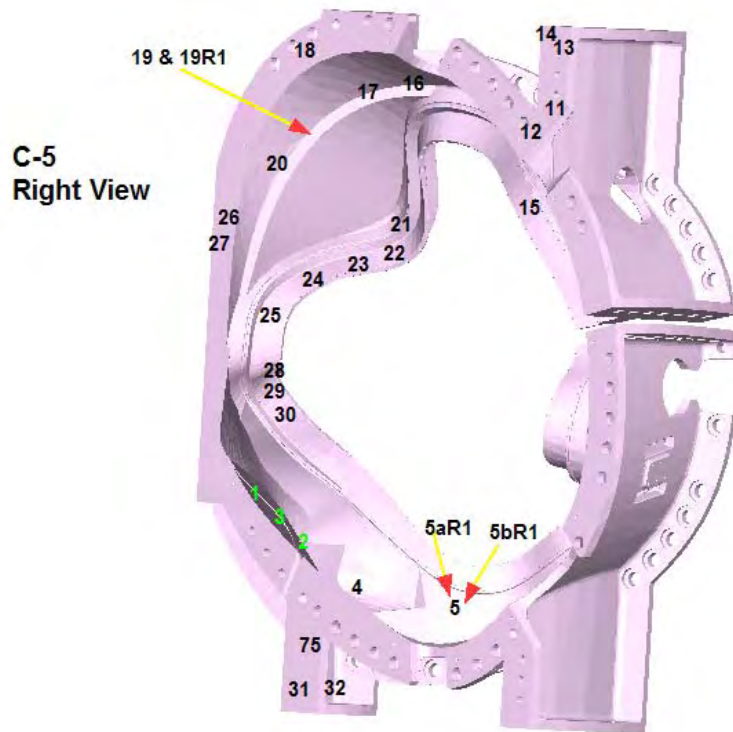

C-5 Coil Weld Map – Metal Tek

Map of all major welds exceeding 20% of wall, over 1 inch or over 10² inches

C-5
Front View



C-5 Coil Weld Map – Metal Tek

Map of all major welds exceeding 20% of wall, over 1 inch or over 10² inches

C-5
Back View

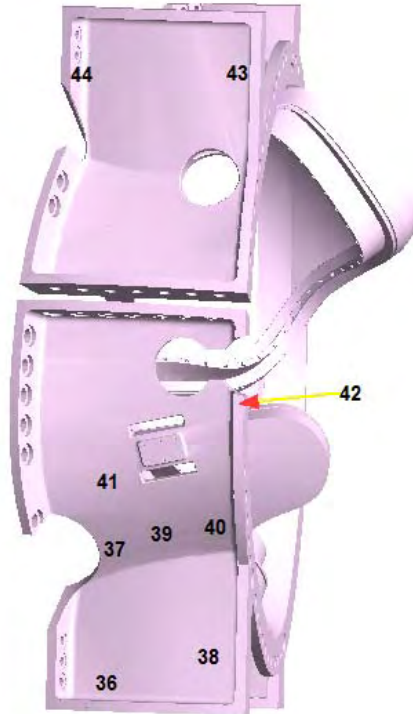

C-5 Coil Weld Map – Metal Tek

Map of all major welds exceeding 20% of wall, over 1 inch or over 10² inches

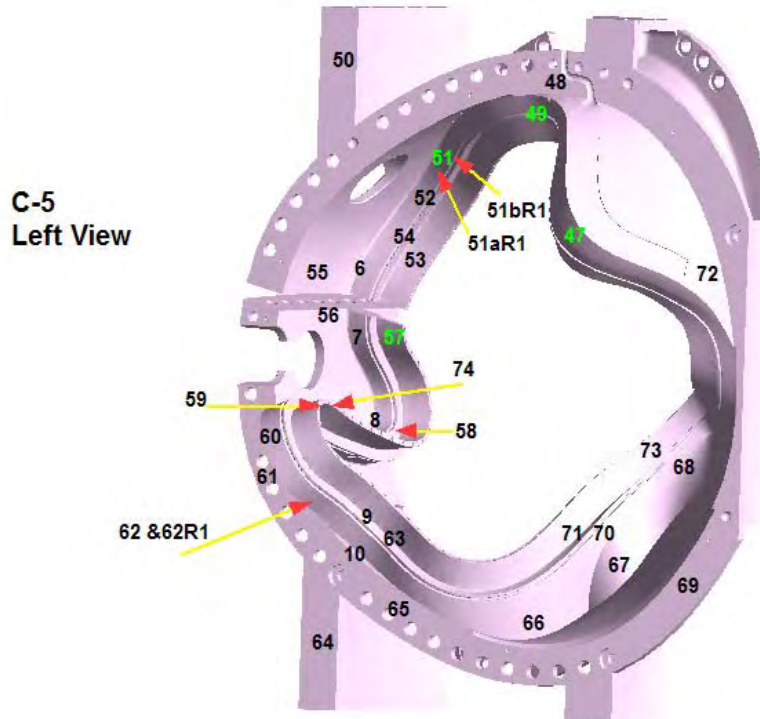

C-5 Coil Weld Map – Metal Tek

Map of all major welds exceeding 20% of wall, over 1 inch or over 10² inches

Top View



C-5 Coil Weld Map – Metal Tek

Map of all major welds exceeding 20% of wall, over 1 inch or over 10² inches

C-5
Bottom View

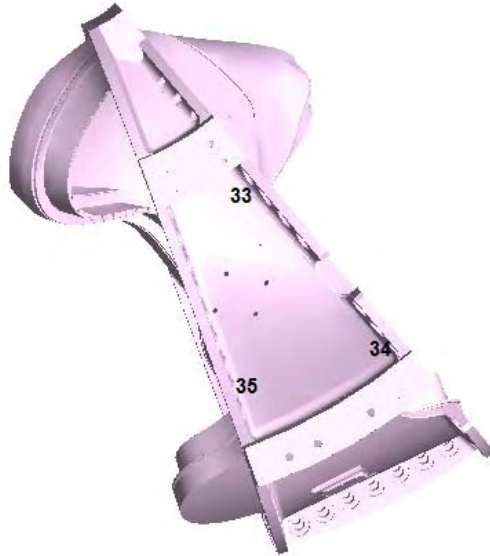



RADIOGRAPHIC STANDARD SHOOTING SKETCH

Customer	E. I. O.	Pattern Number	MCWF-C5
Material	CF8MNMN MOD	Traceability Number	
Film Manufacturer	FUJI	Source Number	E060 22.7 CI
IQI LEVEL <u>2-2T</u> From CQP 401 <input checked="" type="checkbox"/> Other (Specify, E.G. 2-4T, 2-1T) <u>N/A</u>			

Exposures (views)	83-84	103-104	104-105	109-110	H-I	X-Y						
Thickness (IN.)	1 1/2" → 3"	2 3/4"			3" → 6"							
S/F Distance (IN.)	20"											
Penetrator	3060 4060	50 x2			60x2 120x2							
Time (MIN.)	15min	8min 30sec		16min	1hr 45min							
Focal Spot (IN.)	.125											
Film Size (IN.)	14x17											
Screen Size (Pb)	.01											
Front/Back												
S.W.E./D.W.E.	SWE											
S.W.V/D.W.V.	SWV											
Film Type	29 5980	80x2		59/80	29x2 5980							
Acceptance Standard	MSS-SP-54											
Severity Level	See SPEC.											

Shooting Sketch (Use Additional Pages as Needed)

Technique Prepared By: Ron Kelley Level: II Date: 11-7-05
 Technique Approved By: _____ Level: _____ Date: _____

RADIOGRAPHIC STANDARD SHOOTING SKETCH

Customer Energy Industries of Ohio	Pattern Number SE-141-073 C skin
Material CF8MNMN-MOD	Traceability Number
Film Manufacturer Fuji	Source Number C060 24.7 ci
IQI LEVEL 2-2T From CQP 401 <input checked="" type="checkbox"/> Other (Specify, E.G. 2-4T, 2-1T) N/A	

Exposures (views)	A	B	C	D						
Thickness (IN.)	3 7/8"	→								
S/F Distance (IN.)	24"	→								
Penetrator	50	→								
Time (MIN.)	22 min	→								
Focal Spot (IN.)	.1	→								
Film Size (IN.)	14X17	→								
Screen Size (Pb)	.01	→								
Front/Back	SWE	→								
S.W.E./D.W.E.	SWE	→								
S.W.V./D.W.V.	SWV	→								
Film Type	80	→								
Acceptance Standard	E186	→								
Severity Level	III	→								

Shooting Sketch (Use Additional Pages as Needed)

Use spec. MSS-SP-54

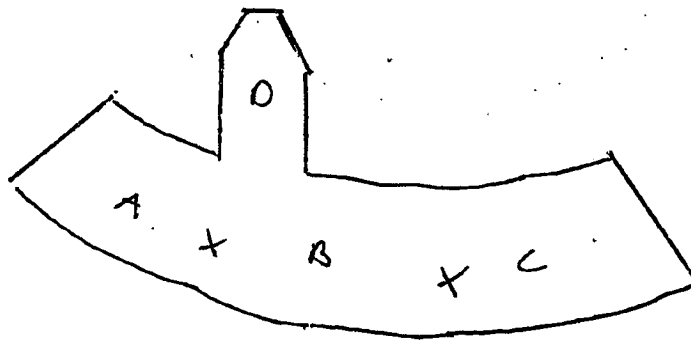

TYP. Source Placement

TYP. Film Placement

Technique Prepared By: **RON Kelley**
 Technique Approved By: **RS**

Level: **II**
 Level: **III**

Date: **9-9-05**
 Date: **9/10/05**

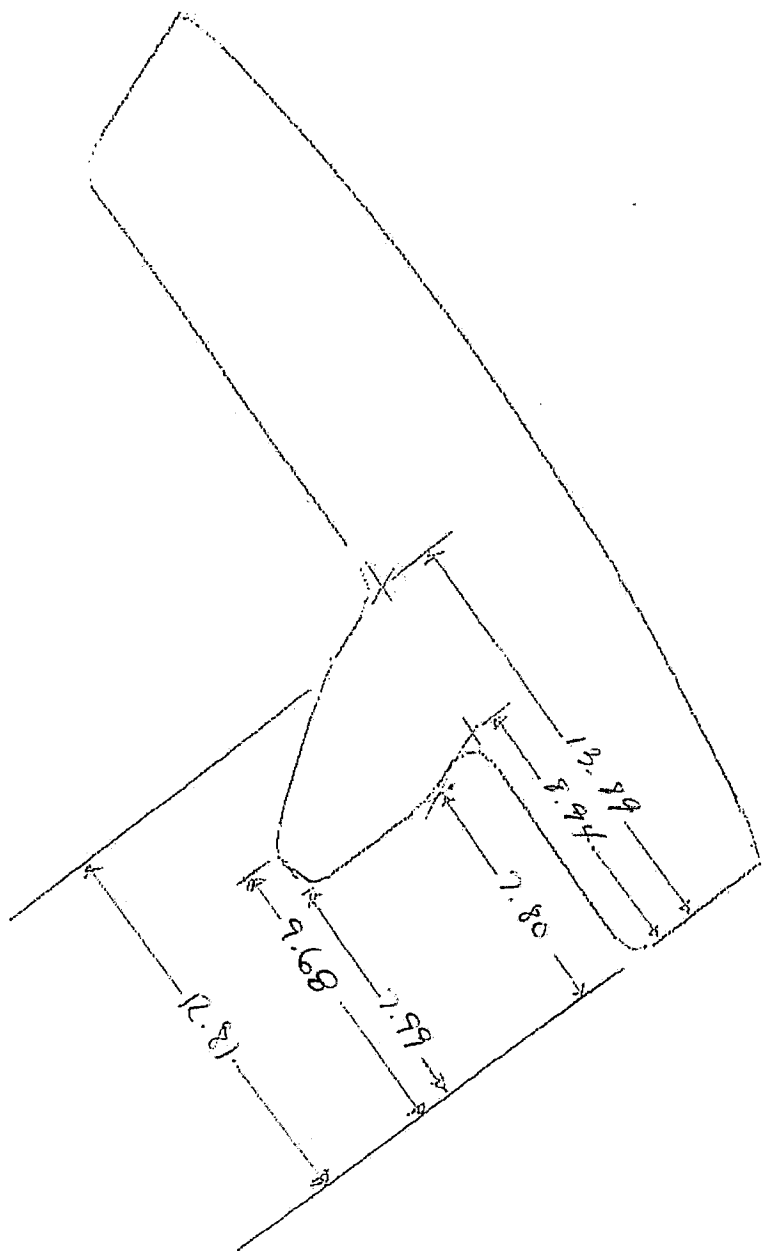

PAGE 2 OF 2.
 SHIM SE 141-073 (5)

Q A

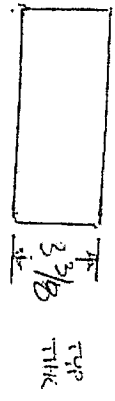

Sheet A-A

HW SE 141-073
 SKETCH 9/12/05
 PAGES 1 OF 2

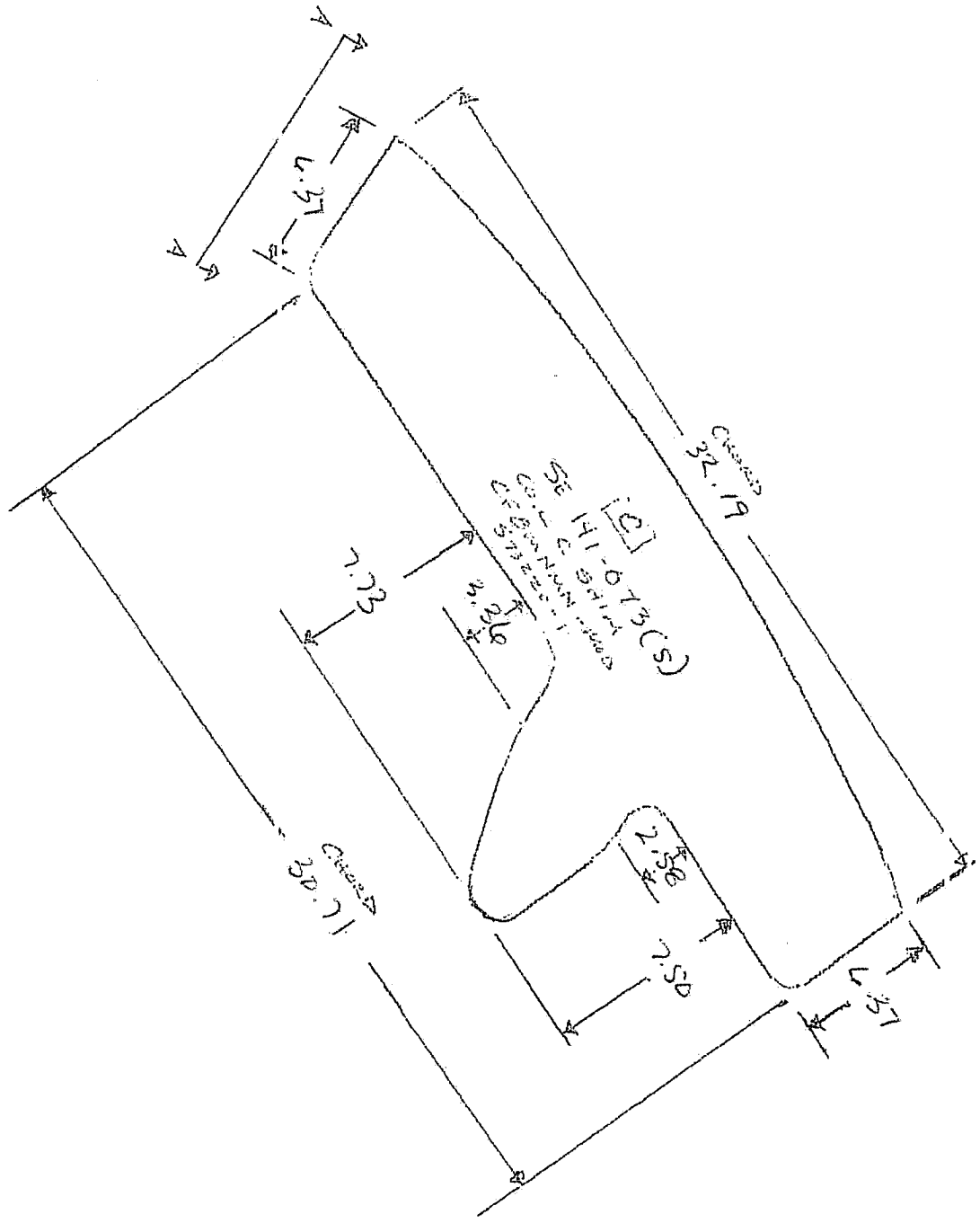

TEAM COOPERHEAT-MQS, INC.

CERTIFIED RADIOGRAPHIC INSPECTION REPORT

FORM 6061-RT- 002 Rev.2

5512 W. State St. Milwaukee, WI 53208 Tel:(414)771-3060 Fax:(414)771-9481 (800)818-6403 www.cooperheat-mqs.com

CUSTOMER		DATE	WORK ORDER NO.
NAME METAL TEK INTERNATIONAL		8/31/2005	361-02500-1
ADDRESS 8600 COMMERCIAL BLVD		P.O. NUMBER	XRAY X
CITY PEVELY STATE MO ZIP 63070		21818	GAMMA
PROCEDURE SPECIFICATION	ACCEPTANCE CRITERIA	SHEET ____ OF ____	
ASTM E94-93	MSS-SP-54-1999		

PART NUMBER	Serial No	View	No Apparent Indications		Dross		Incomplete Penetration		Shrinkage		Film Artifacts		REMARKS
			Acceptable	Rejected	Inclusion	Porosity	Lack of Fusion	Gas Cracks	Hot Tears	Undercut	Surface		
MCWF-C-5		1-2		R									
		2-3	✓										
E.I.O. C040851		3-4	✓										
		4-5		R									
MS172810		5-6		R									
		7-8	✓									✓	
		8-9	✓							1-2		✓	
		9-10	✓									✓	
		11-12	✓										
		12-13	✓										
		13-14	✓		2								
		15-16	✓										
		16-17	✓										
		18-19	✓										
		19-20	✓										
		20-21	✓										
		21-22		R									
		23-24	✓										
		24-25	✓										
		26-27	✓										
		27-28	✓										
		29-30	✓									✓	
		30-31	✓									✓	
		32-33	✓										
		33-34	✓									✓	

NO. ACCEPTED	NO. REJECTED	MQS TECH. NO.	SHT.	REV. 1
0	1	12970		
COMMENTS		CUST. RSS NO.	SHT.	REV.
		REVIEWER		
		CERTIFIED NDT LEVEL (RT)		
		John Petroske RT II Exp. 01/08		

TEAM COOPERHEAT-MQS, INC.

CERTIFIED RADIOGRAPHIC INSPECTION REPORT

FORM 6061-RT- 002 Rev.2

5512 W. State St. Milwaukee, WI 53208 Tel:(414)771-3060 Fax:(414)771-9481 (800)818-6403 www.cooperheat-mqs.com

CUSTOMER		DATE	WORK ORDER NO.
NAME METAL TEK INTERNATIONAL		8/31/2005	361-02500-1
ADDRESS 8600 COMMERCIAL BLVD		P.O. NUMBER	XRAY X
CITY PEVELY STATE MO ZIP 63070		21818	GAMMA
PROCEDURE SPECIFICATION	ACCEPTANCE CRITERIA	SHEET ____ OF ____	
ASTM E94-93	MSS-SP-54-1999		

PART NUMBER	Serial No	View	No Apparent Indications		Incomplete Penetration		Shrinkage		Film Artifacts		REMARKS
			Acceptable	Rejected	Dross or Slag	Porosity	Lack of Fusion	Gas Cracks	Hot Tears	Under Surface	
MCWF-C-5	35-36		✓							✓	
	36-37			R	5			R			
E.I.O. C040851	38-39		✓								✓
	39-40		✓				1				✓
MS172810	41-42			R			3-4		R		✓
	42-43			R					R		✓
	44-45			R			3				
	45-46		✓		1						✓
	47-48			R			3-4		R		✓
	48-49			R			4		R		✓
	49-50-51			R			3-4		R		✓
	52-53			R				4			
	53-54		✓								
	54-55		✓								
	55-56		✓								
	56-57		✓								
	57-58		✓								
	58-59		✓		1						
	59-60		✓		1		2				✓
	60-61		✓				2				✓
	62-63		✓				2				
	63-64		✓								
	65-66		✓								
	67-68		✓						2		
	68-69		✓						3		

NO. ACCEPTED	0	NO. REJECTED	1	MQS TECH. NO.	12970	SHT.	REV. 1
--------------	---	--------------	---	---------------	-------	------	--------

COMMENTS	REVIEWER	CERTIFIED NDT LEVEL (RT)
V64 not included. This view was only shot for a dig out in this Area on previous castings.	<i>John Petroske</i>	John Petroske RT II Exp. 01/08

TEAM COOPERHEAT-MQS, INC.

CERTIFIED RADIOGRAPHIC INSPECTION REPORT

FORM 6061-RT- 002 Rev.2

5512 W. State St. Milwaukee, WI 53208 Tel:(414)771-3060 Fax:(414)771-9481 (800)818-6403 www.cooperheat-mqs.com

CUSTOMER		DATE	WORK ORDER NO.
NAME METAL TEK INTERNATIONAL		8/31/2005	361-02500-1
ADDRESS 8600 COMMERCIAL BLVD		P.O. NUMBER	XRAY X
CITY PEVELY STATE MO ZIP 63070		21818	GAMMA
PROCEDURE SPECIFICATION	ACCEPTANCE CRITERIA	SHEET ____ OF ____	
ASTM E94-93	MSS-SP-54-1999		

PART NUMBER	Serial No	View	No Apparent Indications		Dross		Incomplete Penetration		Shrinkage		Film Artifacts		REMARKS
			Acceptable	Rejected	Inclusion	or Porosity	Lack of Fusion	Gas Cracks	Hot Tears	Under cut	Surface		
MCWF-C-5	69-70	✓										✓	
	71-72	✓							2-3				
E.I.O. C040851	72-73	✓							2				
	73-74	✓										✓	✓
MS172810	74-75	✓										✓	
	75-76	✓										✓	
	76-77	✓							1			✓	
	78-79	✓							2			✓	
	79-80	✓										✓	
	80-81	✓							3			✓	
	81-82				R				3-4		R		
	83-84				R				3			✓	
	85-86				R				3-4				
	86-87	✓											✓
	87-88				R				2		R	✓	
	88-89				R						R		
	90-91				R				5			✓	
	92-93				R				5			✓	
	94	✓										✓	
	95	✓											✓
	96-97				R	R						✓	
	97-98				R						R		
	98-99	✓											✓
	100-101	✓										✓	
	101-102	✓											✓

NO. ACCEPTED	NO. REJECTED	MQS TECH. NO.	SHT.	REV. 1
0	1	12970		
COMMENTS		CUST. RSS NO.	SHT.	REV.
		REVIEWER		
		CERTIFIED NDT LEVEL (RT)		
		John Petroske RT II Exp. 01/08		

TEAM COOPERHEAT-MQS, INC.

CERTIFIED RADIOGRAPHIC INSPECTION REPORT

FORM 6061-RT- 002 Rev.2

5512 W. State St. Milwaukee, WI 53208 Tel:(414)771-3060 Fax:(414)771-9481 (800)818-6403 www.cooperheat-mqs.com

CUSTOMER		DATE	WORK ORDER NO.
NAME <u>METAL TEK INTERNATIONAL</u>		<u>8/31/2005</u>	<u>361-02500-1</u>
ADDRESS <u>8600 COMMERCIAL BLVD</u>		P.O. NUMBER	XRAY X
CITY <u>PEVELY</u> STATE <u>MO</u> ZIP <u>63070</u>		<u>21818</u>	GAMMA
PROCEDURE SPECIFICATION	ACCEPTANCE CRITERIA	SHEET ____ OF ____	
<u>ASTM E94-93</u>	<u>MSS-SP-54-1999</u>		

PART NUMBER	Serial No	View	No Apparent Indications		Incomplete Penetration		Shrinkage			Film Artifacts			REMARKS
			Acceptable	Rejected	Dross or Slag	Porosity	Lack of Fusion	Gas Cracks	Hot Tears	Under cut	Surface		
MCWF-C-5	102-103		✓										
	103-104			R						R			
E.I.O. C040851	104-105			R	5					R			
	106-107			R						R			
MS172810	107-108		✓									✓	
	108-109			R						R			
	109-110			R	5					R			
	111-112		✓										
	112-113			R	5								
	114-115		✓										
	115-116		✓										
	116-117			R						R			

NO. ACCEPTED <u>0</u>	NO. REJECTED <u>1</u>	MQS TECH. NO. <u>12970</u>	SHT. <u>1</u>	REV. <u>1</u>
COMMENTS		CUST. RSS NO.	SHT.	REV.
		REVIEWER <u>John Petroske</u>		
		CERTIFIED NDT LEVEL (RT)		
		John Petroske RT II Exp. 01/08		

TEAM COOPERHEAT-MQS, INC.

CERTIFIED RADIOGRAPHIC INSPECTION REPORT

FORM 6061-RT- 002 Rev.2

5512 W. State St. Milwaukee, WI 53208 Tel:(414)771-3060 Fax:(414)771-9481 (800)818-6403 www.cooperheat-mqs.com

CUSTOMER		DATE	WORK ORDER NO.
NAME METAL TEK INTERNATIONAL		8/31/2005	361-02500-1
ADDRESS 8600 COMMERCIAL BLVD		P.O. NUMBER	XRAY X
CITY PEVELY STATE MO ZIP 63070		21818	GAMMA
PROCEDURE SPECIFICATION	ACCEPTANCE CRITERIA	SHEET ____ OF ____	
ASTM E94-93	MSS-SP-54-1999		

PART NUMBER	Serial No	View	No Apparent Indications		Dross		Incomplete Penetration		Shrinkage		Film Artifacts		REMARKS
			Acceptable	Rejected	Inclusion	Porosity	Lack of Fusion	Gas Cracks	Hot Tears	Undercut	Surface		
MCWF-C-5		AB		R					5				
		B-C		R					5				
E.I.O. C040851		C-D		R					5				
		D-E	✓						2				
MS172810		E-F	✓									✓	
		F-G	✓						3				
		G-H		R					5				
		H-I		R					5				
		I-J		R					5				
		J-K	✓						3				
		K-L		R					3		R		
		L-M		R					3		R		
		M-N		R					5				
		N-O	✓						3				
		O-P	✓						2				
		P-Q	✓						2				
		Q-R	✓						3				
		R-S	✓						1				
		S-T	✓										
		T-U	✓										
		U-V	✓						2-3				
		V-W		R					5				
		W-X		R					5				
		X-Y		R					5				
		Y-Z		R					4-5			✓	

NO. ACCEPTED	NO. REJECTED	MQS TECH. NO.	SHT.	REV. 1
0	1	12970		
COMMENTS		CUST. RSS NO.	SHT.	REV.
		REVIEWER		
		CERTIFIED NDT LEVEL (RT)		
		John Petroske RT II Exp. 01/08		

TEAM COOPERHEAT-MQS, INC.

CERTIFIED RADIOGRAPHIC INSPECTION REPORT

FORM 6061-RT- 002 Rev.2

5512 W. State St. Milwaukee, WI 53208 Tel:(414)771-3060 Fax:(414)771-9481 (800)818-6403 www.cooperheat-mqs.com

CUSTOMER		DATE	WORK ORDER NO.
NAME METAL TEK INTERNATIONAL		10/13/2005	361-02646
ADDRESS 8600 COMMERCIAL BLVD		P.O. NUMBER	XRAY X
CITY PEVELY STATE MO ZIP 63070			GAMMA
PROCEDURE SPECIFICATION ASTM E94-93	ACCEPTANCE CRITERIA MSS-SP-54-1999	SHEET ____ OF ____	

PART NUMBER	Serial No	View	No Apparent Indications		Incomplete Penetration		Shrinkage		Film Artifacts		REMARKS
			Acceptable	Rejection	Dross or Porosity	Lack of Fusion Gas Cracks	Hot Tears	Under cut	Surface		
MCWF-C5	5	1-2	✓		1-2			1-2			
	21	4-5	✓								✓
E.I.O. C040851		5-6	✓					2			
		21-22	✓								
M172810		36-37	✓								
		41-42	✓					1-2			✓
		42-43	✓								✓
		44-45	✓					2			✓
		47-48	✓					1			✓
		48-49	✓								✓
	49	50-51	✓					2			
		52-53	✓								✓
		81-82	✓		1-2						✓
		83-84		R				4			✓
		85-86	✓		1-2						✓
		87-88	✓								✓
		88-89	✓					1			✓
		90-91	✓								✓
		92-93	✓					1-2			✓
		96-97	✓								✓
		97-98	✓		1-2						✓
	103	104		R					R		✓
	104	105		R					R		✓
		106-107	✓								✓
		108-109	✓								✓

NO. ACCEPTED	NO. REJECTED	MQS TECH. NO.	SHT.	REV.
0	1	12970		
COMMENTS		CUST. RSS NO.	SHT.	REV.
		REVIEWER		
		John Petroske		
		CERTIFIED NOT LEVEL (RT)		
		John Petroske RT II Exp. 01/08		

TEAM COOPERHEAT-MQS, INC.

CERTIFIED RADIOGRAPHIC INSPECTION REPORT

FORM 6061-RT- 002 Rev.2

5512 W. State St. Milwaukee, WI 53208 Tel:(414)771-3060 Fax:(414)771-9481 (800)818-6403 www.cooperheat-mqs.com

CUSTOMER		DATE	WORK ORDER NO.
NAME METAL TEK INTERNATIONAL		10/13/2005	361-02646
ADDRESS 8600 COMMERCIAL BLVD		P.O. NUMBER	XRAY X
CITY PEVELY STATE MO ZIP 63070			GAMMA
PROCEDURE SPECIFICATION ASTM E94-93	ACCEPTANCE CRITERIA MSS-SP-54-1999	SHEET ____ OF ____	

PART NUMBER	Serial No	View	No Apparent Indications		Dross		Incomplete Penetration		Shrinkage		Film Artifacts		REMARKS
			Acceptable	Rejected	Inclusion	or Porosity	Lack of Fusion	Gas Cracks	Hot Tears	Under cut	Surface		
MCWF-C5	5	AB	✓						2				
	RI	B-C	✓										
E.I.O. C040851		C-D	✓						2-3				
		G-H	✓										
M172810		H-I			R					4-5		✓	Sec 83-84
		I-J	✓						3				
		K-L	✓						2-3				
		L-M	✓						1-2				
		M-N	✓						1				
		V-W	✓						2				
		W-X	✓						2				
		Y-Z	✓										
		X-Y			R				4-5			✓	
		Z-AA	✓										
		BB	✓										
		CC-DD	✓						1			✓	
		DD-A	✓						1				

NO. ACCEPTED	NO. REJECTED	MQS TECH. NO.	SHT.	REV.
0	1	12970		
COMMENTS		CUST. RSS NO.	SHT.	REV.
V-W, WX There is room for only 1 1/2 open in these views		REVIEWER		
		CERTIFIED NOT LEVEL (RT)		
		John Petroske RT II Exp. 01/08		

MetalTek

INTERNATIONAL

RADIOGRAPHIC INTERPRETATION REPORT

CUSTOMER E.I.O	PURCHASE ORDER NUMBER PPPI -FP-LTS-2	DATE 11-7-05	CONTROL NO. 40851	PAGE 106/1							
PART NO. MCWFC-5	SPECIFICATION E44/E186	CLASS see spec	TOTAL PIECES 1	PIECES ACCEPTED 1							
RADIOGRAPHED BY: Midsert/Kelley		INTERPRETED BY: At Kelley		ASNT LEVEL II							
FILM TYPE 29/59/80	MATERIAL CF8M/INM MOD	ISOTOPE IRIDIUM 192 COBALT 60 V									
		CODE ASTM E94 V ASME MIL-STD-453									
M172810	V I E W	P E N E	A C C E P T	R E J E C T	S H R I N K	I N C L U S I O N	P O R O S I T Y	L I N E A R	S U R F A C E	L O F / L O P	COMMENTS
R2	83-84	30/40	/				2				
	103-104	50	/			1	1		/		
	104-105	↓	/		1	1			/		
	109-110	↓		X						X	
	H-I	60/120	/		2	1					
	X-Y	6		X	X						
R3	109-110	50	/			1	1		/		
	X-Y	60/120	/			1	1		/		

E10 8-13-05

MCWF-C5 COIL

172810 -1

1 Pc.

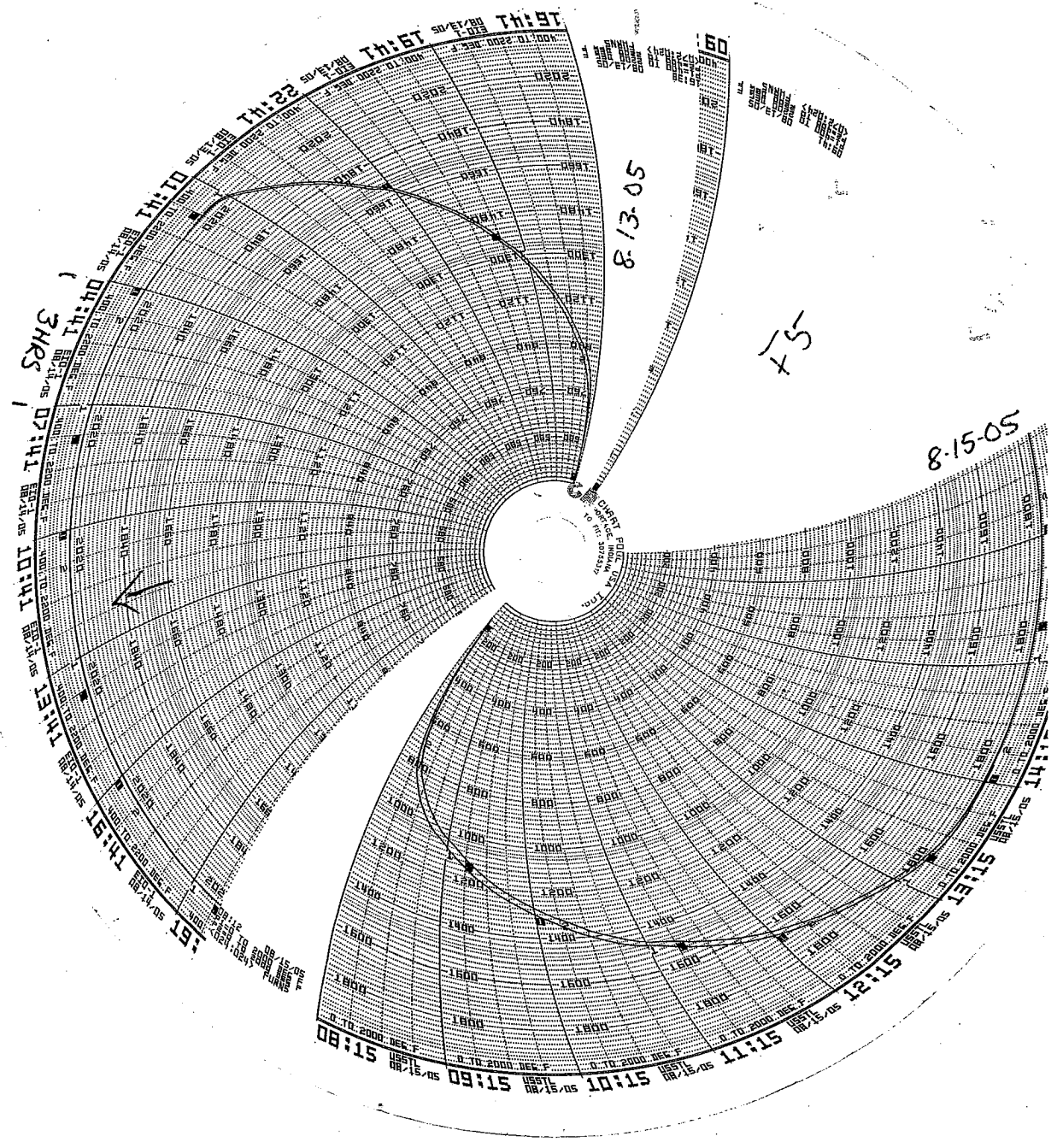

E10 11-14-05
MCWF-C5 coil
172810-1
1 Pc.

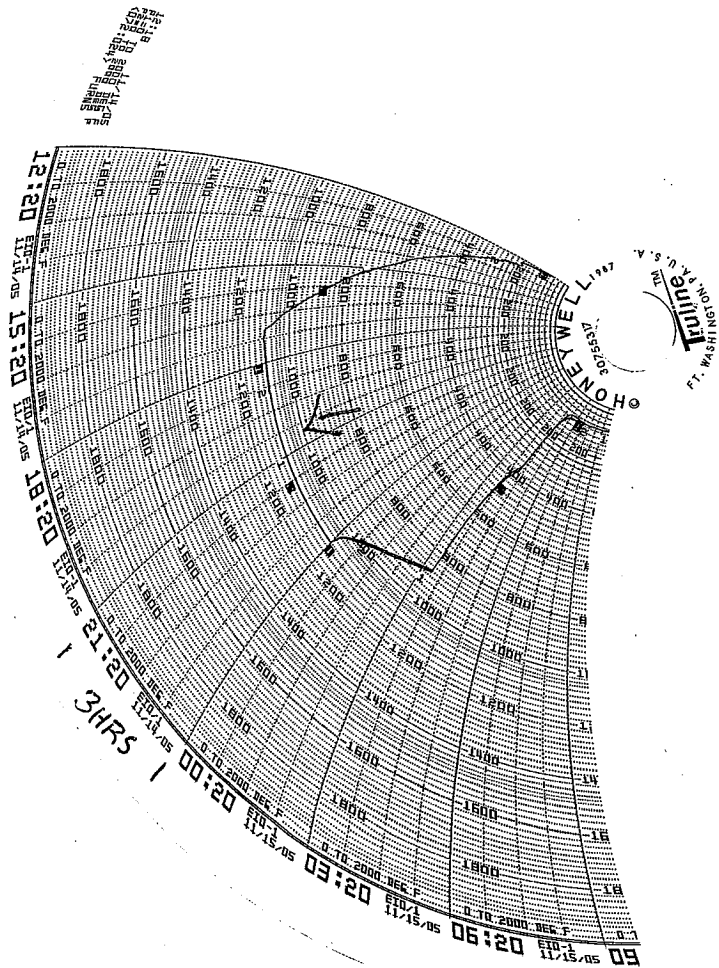

Energy Industries of Ohio
 Manufacturing and Test Sequence (MTS) Serial Number C-5 Coil

1 OF 11 CO# 40851 Dated 3-9-05 Revision: Rev 8 Dated Issued:7-29-05

OPER. #	STATION	DESCRIPTION OF PROCESS	Name	Date
10	QUALITY RELEASE	REVIEW AND APPROVE MTS. RECEIVED APPROVAL FROM EIO ON _8-3-05 FROM _Pete D._ SIGNED QUALITY MANAGER	<i>CD</i>	
15	PATTERN NPAT SOP 0100REV2	APPLY APPROPRIATE PART NUMBER, SERIAL NUMBER, AND FOUNDRY MARK, TO THE PATTERN. CAST ON TEST BARS AND CAST ON BLOCKS (extra 3"x3"x1" specimens) REQUIRED, ID AS TO COIL NUMBER AND ZONE LOCATION.	<i>KM</i>	<i>8/3</i>
20	COREMAKE CORE SOP 0100 REV 6 CALIBRATION PER CORE SOP 0200R4/0300R6	MAKE CORES IN SAND MIXTURES AS DESCRIBED BY METALTEK ENGINEERING AND VERIFIED IN MODELING TRIALS. METALTEK CORE SOP 0100 REV 6) CORE WASH WITH ZIRCONIUM CORE WASH. (CALIBRATION OF EQUIPMENT REQUIRED PER CORE SOP 0200,R4 / 0300,R6) VERIFY COUNT AND INSPECT.	<i>BC</i>	<i>8/4/05</i>
30	MOLD MOLD SOP 0400 REV 8 CALIBRATION PER MOLD SOP 0900 REV 5 PREPARATION PER MOLD SOP 1100R2/1200R2/1300R1 SAND TESTING PER MOLD SOP 1400R2/1500R3/1600R2	MOLD PER WORK INSTRUCTIONS IN MAPICS ROUTING AND SOPS REFERENCED. ENGINEER OF RECORD - ROGER BROMAN, CONSULT ON MOLD-RELATED CONCERNS. MOLD MATERIALS REQUIRED PER MAPICS BOM. NOTIFY ENGINEER OF ANY SUBSTITUTIONS.	<i>BC</i>	<i>8/8/05</i>
40	POUR MELT SOP 0100R5 MELT SOP 0700R2 MELT SOP 0600R2	METAL MUST BE AOD REFINED OR AOD INGOT. VIRGIN METAL ADDITIONS ALLOWED. RECORD POURING TEMPERATURE: <u>2745</u> CASTING POURED AT: <u>330 AM</u> DATE: <u>8/08/05</u> HEAT #'s: <u>30441, 30445</u> ELAPSED POUR TIME <u>25 min</u> KEEL BLOCKS POURED: <u>NA</u> Sample from ladle to be analyzed for final chemical analysis and reported on material certifications. Sample Taken by: <u>J. Wilson</u> Analyzed: <u>G. Hunt</u> Date: <u>8/8</u>	<i>JWG</i>	<i>8/12/05</i>
50	MELT SOP 0800R2	SHAKEOUT	<i>CA</i>	<i>8/11</i>

Energy Industries of Ohio
 Manufacturing and Test Sequence (MTS) Serial Number C-5 Coil
 2 OF 11 CO# 40851 Dated 3-9-05 Revision: Rev 8 Dated Issued: 7-29-05

60	ARC RISE SOP 0100R1	REMOVE RISERS AS DIRECTED BY SUPERVISOR.	JC	8/19
70	HEAT TREAT HEAT SOP 0103R5	SOLUTION ANNEAL. MAKE SURE TO BLOCK ALL FLANGES OF FORM AND RACETRACK TO MINIMIZE CREEP DISTORTION. Soak Temp: 2050F, Soak Time: 4HR + 1/2 HR/IN, Quench Type: Air Cool MAKE SURE TEST MATERIAL IS PLACED IN THE CORRECT ZONE.	RJ	8/14/05
75	PHYSICAL TESTING	OBTAIN TEST SPECIMENS AND SUBMIT FOR PHYSICAL TESTING. REPORT RESULTS AS PART OF STEP 510.	WH	8/15/05
NOTE		THE ORDER OF CLEANING PROCESSES MAY BE ALTERED DUE TO CAPACITY CONSTRAINTS. HOLD POINTS AND COMPLIANCE WILL NOT BE COMPROMISED. EIO WILL BE ADVISED OF ALL CHANGES THAT MAY RESULT IN A REQUEST FOR DEVIATION FROM REQUIREMENTS.		
80	GRIND GSAW SOP 0100R3	SWING GRIND TO REMOVE RISER REMAINS AND FLASH IF REQUIRED.	JLC	8/16/05
85	GRIND GCHI SOP 0100R2	CHIP AND HAD GRIND SURFACE OF PART AS REQUIRED FOR CONTOUR.	CAK	8/22/05
90	SAND BLAST BLAS SOP 0100R6	SANDBLAST (REMOVE ALL BLAST MATERIAL FROM CASTING) SANDBLASTING WILL BE DONE USING RECYCLED SHARP ANGULAR AGGREGATE.	MTW	8/23/05
NOTICE	WITNESS NOTIFICATION	PROVIDE NOTICE TO EIO AND DCMA AT LEAST FIVE DAYS IN ADVANCE OF LAYOUT. EIO NOTIFIED ON <u>11/1</u> DCMA NOTIFIED ON <u>11/1</u> APPROVAL RECEIVED ON <u>NA</u>	Q ENG OR QA MGR	Chc
100	INTERIM LAYOUT SOP LAYOUT 0100	INSPECT CASTING TO VERIFY DIMENSIONS. THIS STEP MAY BE DELAYED UNTIL ALL REPAIRS ARE COMPLETE. NOTE: THE FIRST PART PRODUCED OF EACH TYPE A, B AND C WILL BE DIMENSIONED BY LAWTON PATTERN. IF DIMENSIONED BY LAWTON IT WILL BE DOCUMENTED HERE. Subsequent casting done internally per Romer Arm.	Jody	11/8/05
110	INTERIM VISUAL INSPECTION CQP-500 REV 4	VISUALLY INSPECT 100% of COMPONENT ACCORDING TO ASTM A802 LEVEL 3 IN NON MACHINED AREAS AND LEVEL 2 IN MACHINED AREAS. IF OK CHECK HERE _____ IF REJECTED CHECK HERE _____. MARK AND REPAIR AT STEP 120.	VT - LEVEL II	NA
NOTICE	WITNESS NOTIFICATION	PROVIDE NOTICE TO EIO AND DCMA AT LEAST FIVE DAYS IN ADVANCE OF LP STEP. EIO NOTIFIED ON _____ DCMA NOTIFIED ON _____	Q ENG OR QA MGR	↓

Vis +
2PI
delayed
take off
RT
Chc

**Energy Industries of Ohio
Manufacturing and Test Sequence (MTS) Serial Number C-5 Coil**

3 OF 11 CO# 40851 Dated 3-9-05 Revision: Rev 8 Dated Issued:7-29-05

115	INTERIM 100% L.P. CQP 0300 REV 10	L.P. 100% OF COMPONENT. ACCEPTANCE PER ASTM A903. ACCEPTANCE CRITERIA- LEVEL 1 FOR HIGH STRESSED AREAS, LEVEL 2 FOR ALL OTHER AREAS. SEE LP DRAWING. IF OK CHECK HERE _____ IF REJECTED CHECK HERE _____ MARK AND REPAIR AT STEP 120.	LP - LEVEL II	
120	WELD SOP 0100 REV 7	EXCAVATE ANY DEFECTS FOUND DURING 100% VISUAL AND LP INSPECTION.		
125	GRIND GCHI SOP 0100R2	CHIP AND HAND GRIND EXCAVATION AS REQUIRED.		
130	L.P. EXCAVATION CQP-300 REV 10	L.P. ALL EXCAVATIONS PRIOR TO WELDING TO ENSURE REMOVAL OF DEFECT. ACCEPTANCE PER A903. ACCEPTANCE CRITERIA-LEVEL 1 FOR HIGH STRESSED AREAS, LEVEL 2 FOR ALL OTHER AREAS. SEE LP DRAWING. IF OK CHECK HERE _____ IF REJECTED SEND BACK TO STEP 125.	LP - LEVEL II	
165	SAND BLAST BLAS SOP 0100R6	SANDBLAST (REMOVE ALL BLAST MATERIAL FROM CASTING) SANDBLASTING WILL BE DONE USING RECYCLED SHARP ANGULAR AGGREGATE.		
170	WELD MAP	MAP ALL MAJOR WELDS WITH DIGITAL PHOTO/MAPS INDICATING LOCATION. SERIALIZE DEFECTS ON CASTING, USE SCALE IN PHOTOS AND DOCUMENT SIZE. THIS IS TO BE PERFORMED BY SUPERVISOR, INSPECTION LEAD MAN OR THEIR DESIGNEE, FILE WITH QA. USE YELLOW MARKER. MUST INDICATE ON MAP ALL MAJOR WELDS, DEFINED AS GREATER THAN 20% OF THE WALL OR 1 INCH WHICHEVER IS LESS OR 10 SQUARE INCHES APPROXIMATLY 3.3"X3.3".		
NOTICE	WITNESS NOTIFICATION	PROVIDE NOTICE TO EIO AND DCMA AT LEAST FIVE DAYS IN ADVANCE OF X-RAY AND DIMENSIONAL STEPS. EIO NOTIFIED ON <u>8/23/05</u> DCMA NOTIFIED ON <u>8/23/05</u>	Q ENG OR QA MGR	RMS
190	X-RAY AT MQS MQS PROCEDURE 20.H.010 REV 0	X-RAY PER TECHNIQUE # 12726 USE CALIBRATED DENSITOMETER FOR DENSITY VERIFICATION. WHEN MARKING USE BLACK MARKERS. ATTACH TECHNIQUE, READER SHEET FOR ALL RADIOGRAPHS. MUST INDICATE RADIOGRAPHER AND ASNT CERTIFICATION LEVEL ON READER SHEET.	RT - LEVEL II 8/27/05	RMS
210	X-RAY CQP 401 REV 5	X-RAY INTERPRETATION. ACCEPTANCE MSS SP 54. ATTACH TECHNIQUE, READER SHEET FOR ALL RADIOGRAPHS. MUST INDICATE RADIOGRAPHER AND ASNT CERTIFICATION LEVEL ON READER SHEET. IF OK CHECK HERE _____ AND SEND TO STEP 260. REJECTED CHECK HERE _____ MARK UP DEFECTS AND SEND THE CASTING TO STEP 220.	RT - LEVEL II 9/14 DM	DCMA STAD 9/14/05

NA

**Energy Industries of Ohio
Manufacturing and Test Sequence (MTS) Serial Number C-5 Coil**

4 OF 11 CO# 40851 Dated 3-9-05 Revision: Rev 8 Dated Issued:7-29-05

220	WELD SOP 0100 REV 7	EXCAVATE ANY DEFECTS FOUND DURING RADIOGRAPHY.	✓	
225	GRIND GCHI SOP 0100R2	CHIP AND HAND GRIND EXCAVATION AS REQUIRED.	CA	9/14
230	L.P. EXCAVATION CQP-300 REV 10	L.P. ALL EXCAVATIONS PRIOR TO WELDING TO ENSURE REMOVAL OF DEFECT. ACCEPTANCE PER A903. ACCEPTANCE CRITERIA-LEVEL 1 FOR HIGH STRESSED AREAS, LEVEL 2 FOR ALL OTHER AREAS. SEE LP DRAWING. IF OK CHECK HERE _____ IF REJECTED SEND BACK TO STEP 225.	LP - LEVEL II TRC	9/14/05
240	WELD MAP	MAP ALL WELDS WITH DIGITAL PHOTO/MAPS INDICATING LOCATION. SERIALIZE DEFECTS ON CASTING, USE SCALE IN PHOTOS AND DOCUMENT SIZE. THIS IS TO BE PERFORMED BY SUPERVISOR, INSPECTION LEAD MAN OR THEIR DESIGNEE, FILE WITH QA. USE YELLOW MARKER. MUST INDICATE ON MAP ALL MAJOR WELDS, DEFINED AS GREATER THAN 20% OF THE WALL OR 1 INCH WHICHEVER IS LESS OR 10 SQUARE INCHES APPROXIMATLY 3.3"X3.3".	✓ JR	
NOTICE	WITNESS NOTIFICATION	PROVIDE NOTICE TO EIO AND DCMA AT LEAST FIVE DAYS IN ADVANCE OF WELD STEP. EIO NOTIFIED ON _____ DCMA NOTIFIED ON <u>9/14/05</u>	Q ENG OR QA MGR	RMS
260	QA APPROVAL HOLD POINT	QA TO APPROVE ELECTRODE PRIOR TO USE <u>Level</u> PROCEDURE USED: <u>15GMAW CF8MnNiMo</u> MATERIAL/LOT USED: <u>3018513/78308</u> QUALITY ENG. Name: <u>CA</u> Date: <u>10/6/05</u>		
270	WELD SOP 0100 REV 7	WELD REPAIR DEFECTS AS MARKED. FOR WELDS <2" - WPS 10-SMAW-CF8MNMN MOD REV 1(Flat) or 25 SMAW-CF8MNMN MOD REV 0 (Vertical) FOR WELDS <8" - WPS 15-GMAW-CF8MNMN MOD REV 2	TLs 10/6/05 TAD 10/25/05	
280	GRIND GCHI SOP 0100R2	HAND GRIND WELDS.	DWP KLB	10/19/05
290	L.P. WELD CQP 0300 REV 10	L.P. WELD REPAIRS ACCEPTANCE PER ASTM A903. ACCEPTANCE CRITERIA-LEVEL 1 FOR HIGH STRESSED AREAS, LEVEL 2 FOR ALL OTHER AREAS. SEE LP DRAWING. IF OK CHECK HERE _____ WASH AND SEND TO STEP 300. IF REJECTED CHECK HERE _____	LP - LEVEL II JR Repair Loop	
	REPEAT	REPEAT STEPS <u>220 TO 290</u> AS REQUIRED TILL CLEAR THROUGH VISUAL INSPECTION & PENETRANT INSPECTION. DOCUMENT REWORK ON STEPS S220 TO S290. IF OK CHECK HERE _____ AND PROCEED TO STEP 295.		
	REPEAT STEPS	SUPPLEMENTAL REPAIR STEPS		
S220	WELD SOP 0100 REV 7	EXCAVATE ANY DEFECTS FOUND DURING RADIOGRAPHY.	RT TS 11-9	1 ST 10/31/05 RKR5 2 ND 11/7 Eg 3 RD 11-8-05 TH Accept 4 TH 5 TH

DCMA
STAMP

**Energy Industries of Ohio
Manufacturing and Test Sequence (MTS) Serial Number C-5 Coil**

5 OF 11 CO# 40851 Dated 3-9-05 Revision: Rev 8 Dated Issued: 7-29-05

NA

S230	L.P. EXCAVATION CQP-300 REV 10	L.P. ALL EXCAVATIONS PRIOR TO WELDING TO ENSURE REMOVAL OF DEFECT. ACCEPTANCE PER A903. ACCEPTANCE CRITERIA-LEVEL 1 FOR HIGH STRESSED AREAS, LEVEL 2 FOR ALL OTHER AREAS. SEE LP DRAWING.	LP - LEVEL II				
S240	WELD MAP	MAP ALL MAJOR WELDS WITH DIGITAL PHOTO/MAPS INDICATING LOCATION. SERIALIZE DEFECTS ON CASTING, USE SCALE IN PHOTOS AND DOCUMENT SIZE. THIS IS TO BE PERFORMED BY SUPERVISOR, INSPECTION LEAD MAN OR THEIR DESIGNEE, FILE WITH QA. USE YELLOW MARKER. MUST INDICATE ON MAP ALL MAJOR WELDS, DEFINED AS GREATER THAN 20% OF THE WALL OR 1 INCH WHICHEVER IS LESS OR 10 SQUARE INCHES APPROXIMATLY 3.3"X3.3".					
NOTICE	WITNESS NOTIFICATION	PROVIDE NOTICE TO EIO AND DCMA AT LEAST FIVE DAYS IN ADVANCE OF WELD STEP. EIO NOTIFIED ON _____ DCMA NOTIFIED ON _____	Q ENG OR QA MGR				
S260	QA APPROVAL HOLD POINT	QA TO APPROVE ELECTRODE PRIOR TO USE. PROCEDURE USED: _____ MATERIAL /LOT USED : _____ QUALITY ENG. Name: _____ Date: _____					
S270	WELD SOP 0100 REV 7	WELD REPAIR DEFECTS AS MARKED. FOR WELDS <2" - WPS 10-SMAW-CF8MNMN MOD REV 1(Flat) or 25 SMAW-CF8MNMN MOD REV 0 (Vertical) FOR WELDS <8" - WPS 15-GMAW-CF8MNMN MOD REV 2					
S280	GRIND GCHI SOP 0100R2	HAND GRIND WELDS.					
S290	L.P. WELD CQP 0300 REV 10	L.P. WELD REPAIRS ACCEPTANCE PER ASTM A903. ACCEPTANCE CRITERIA-LEVEL 1 FOR HIGH STRESSED AREAS, LEVEL 2 FOR ALL OTHER AREAS. SEE LP DRAWING. IF OK CHECK HERE _____ WASH AND SEND TO STEP 300. IF REJECTED CHECK HERE _____ AND RETURN TO STEP S220.	LP - LEVEL II MP	OK 11/8 REJ	OK 11/10 REJ	OK	OK
	REPEAT	REPEAT STEPS S220 TO S290 AS REQUIRED TILL CLEAR THROUGH VISUAL INSPECTION & PENETRANT INSPECTION.	QA ENG.				
295	TEST MAG PERM SOP MAG PERM 100, REV 1	TEST MAG PERMEABILITY REPAIR AREAS TEST AT LEAST 5 POINTS PER WELD. ACCEPTANCE 1.02. IF OK CHECK HERE _____ AND GO TO STEP 300. IF REJECTED CHECK HERE _____.				OK 11/8 OK 11/10	
296	GRIND GCHI SOP 0100R2	GRIND AREAS OF NON COMPLIANCE AND RETURN TO STEP 295. REPEAT UNTIL COMPLIANCE IS ACHIEVED.				NA	
300	X-RAY (NOTE)	IF RADIO GRAPHED AREAS ARE GREATER THAN FOUR TO FIVE INCHES THE CASTING WILL BE SENT TO MQS. SEND TO MQS CHECK HERE _____ RADIOGRAPH AT CAF CHECK HERE _____ ✓	QA ENGINE ER				27 clw AT CAF clw

**Energy Industries of Ohio
Manufacturing and Test Sequence (MTS) Serial Number C-5 Coil**

6 OF 11 **CO# 40851 Dated 3-9-05 Revision: Rev 8 Dated Issued:7-29-05**

310 A	MQS X-RAY DEFECTS REPAIRED BY WELDING	X-RAY PER TECHNIQUE # 12726 USE CALIBRATED DENSITOMETER FOR DENSITY VERIFICATION. ATTACH TECHNIQUE, READER SHEET FOR ALL RADIOGRAPHS. MUST INDICATE RADIOGRAPHER AND ASNT CERTIFICATION LEVEL ON READER SHEET.	LEVEL II					
310 B	CAF X-RAY DEFECTS REPAIRED BY WELDING CQP 401 REV 5	X-RAY PER TECHNIQUE # 12726 USE CALIBRATED DENSITOMETER FOR DENSITY VERIFICATION. ATTACH TECHNIQUE, READER SHEET FOR ALL RADIOGRAPHS. MUST INDICATE RADIOGRAPHER AND ASNT CERTIFICATION LEVEL ON READER SHEET.	RT - LEVEL II					
320	X-RAY CQP 401 REV 5	X-RAY INTERPRETATION. ACCEPTANCE MSS SP 54. ATTACH TECHNIQUE, READER SHEET FOR ALL RADIOGRAPHS. MUST INDICATE RADIOGRAPHER AND ASNT CERTIFICATION LEVEL ON READER SHEET. IF OK CHECK HERE _____ AND SEND TO STEP 340. REJECTED CHECK HERE _____ MARK UP DEFECTS AND SEND THE CASTING TO STEP 220.	RT - LEVEL II					su 5220
	REPEAT STEPS	SUPPLEMENTAL REPAIR STEPS	1 ST	2 ND	3 RD	4 TH	5 TH	
S321	WELD SOP 0100 REV 7	EXCAVATE ANY DEFECTS FOUND DURING RADIOGRAPHY.						
S322	L.P. EXCAVATION CQP-300 REV 10	L.P. ALL EXCAVATIONS PRIOR TO WELDING TO ENSURE REMOVAL OF DEFECT. ACCEPTANCE PER A903. ACCEPTANCE CRITERIA-LEVEL 1 FOR HIGH STRESSED AREAS, LEVEL 2 FOR ALL OTHER AREAS. SEE LP DRAWING.	LP - LEVEL II					
S323	WELD MAP	MAP ALL MAJOR WELDS WITH DIGITAL PHOTO/MAPS INDICATING LOCATION. SERIALIZE DEFECTS ON CASTING, USE SCALE IN PHOTOS AND DOCUMENT SIZE. THIS IS TO BE PERFORMED BY SUPERVISOR, INSPECTION LEAD MAN OR THEIR DESIGNEE, FILE WITH QA. USE YELLOW MARKER. MUST INDICATE ON MAP ALL MAJOR WELDS, DEFINED AS GREATER THAN 20% OF THE WALL OR 1 INCH WHICHEVER IS LESS OR 10 SQUARE INCHES APPROXIMATLY 3.3"X3.3".						
NOTICE	WITNESS NOTIFICATION	PROVIDE NOTICE TO EIO AND DCMA AT LEAST FIVE DAYS IN ADVANCE OF WELD STEP. EIO NOTIFIED ON _____ DCMA NOTIFIED ON _____	Q ENG OR QA MGR					
S324	QA APPROVAL HOLD POINT	QA TO APPROVE ELECTRODE PRIOR TO USE. PROCEDURE USED: _____ MATERIAL /LOT USED : _____ QUALITY ENG. Name: _____ Date: _____						
S325	WELD SOP 0100 REV 7	WELD REPAIR DEFECTS AS MARKED. FOR WELDS <2" - WPS 10-SMAW-CF8MNMN MOD REV 1(Flat) or 25 SMAW-						

**Energy Industries of Ohio
Manufacturing and Test Sequence (MTS) Serial Number C-5 Coil**

7 OF 11 CO# 40851 Dated 3-9-05 Revision: Rev 8 Dated Issued:7-29-05

		CF8MNMN MOD REV 0 (Vertical) FOR WELDS <8" - WPS 15-GMAW-CF8MNMN MOD REV 2					
S326	GRIND GCHI SOP 0100R2	HAND GRIND WELDS.	<i>Grind</i>	<i>JR</i>	<i>11/16</i>		
S327	L.P. WELD CQP 0300 REV 10	L.P. WELD REPAIRS ACCEPTANCE PER ASTM A903. ACCEPTANCE CRITERIA-LEVEL 1 FOR HIGH STRESSED AREAS, LEVEL 2 FOR ALL OTHER AREAS. SEE LP DRAWING. IF OK CHECK HERE _____ WASH AND SEND TO STEP 300. IF REJECTED CHECK HERE _____ AND RETURN TO STEP S321.	LP - LEVEL II <i>JR</i>	<i>OK</i>	OK	OK	OK
	REPEAT	REPEAT STEPS S321 TO S327 AS REQUIRED TILL CLEAR THROUGH VISUAL INSPECTION & PENETRANT INSPECTION.	QA ENG.	<i>OK</i>	<i>chr</i>		
340	SAND BLAST BLAS SOP 0100R6	SANDBLAST (REMOVE ALL BLAST MATERIAL FROM CASTING) SANDBLASTING WILL BE DONE USING RECYCLED SHARP ANGULAR AGGREGATE.			<i>BB</i>	<i>11/16</i>	
NOTICE	WITNESS NOTIFICATION	PROVIDE NOTICE TO EIO AND DCMA AT LEAST FIVE DAYS IN ADVANCE OF VISUAL AND LP STEPS. EIO NOTIFIED ON <u><i>11/7</i></u> DCMA NOTIFIED ON <u><i>11/7</i></u>			Q ENG OR QA MGR	<i>chr</i>	
350	FINAL VISUAL INSPECTION CQP-500 REV 4	VISUALLY INSPECT 100% of COMPONENT ACCORDING TO ASTM A802 LEVEL 3 IN NON MACHINED AREAS AND LEVEL 2 IN MACHINED AREAS. IF OK CHECK HERE <u><i>✓</i></u> . IF REJECTED CHECK HERE _____. MARK AND REPAIR AT STEP 385. MUST BE PERFORMED BY LEVEL II in VT.			VT - LEVEL II <i>JDR</i>	<i>11/16</i>	
360	FINAL L.P. CQP 0300 REV 10	FINAL L.P. 100% OF COMPONENT. ACCEPTANCE PER ASTM A903. ACCEPTANCE CRITERIA-LEVEL 1 FOR HIGH STRESSED AREAS, LEVEL 2 FOR ALL OTHER AREAS. SEE LP DRAWING. IF OK CHECK HERE _____ WASH AND SEND TO STEP 455. IF REJECTED CHECK HERE _____			LP - LEVEL II <i>JDR</i>	<i>11/16</i>	
380	WELD SOP 0100 REV 7	EXCAVATE ANY DEFECTS FOUND DURING FINAL PENETRANT INSPECTION.					
385	GRIND GCHI SOP 0100R2	CHIP AND HAD GRIND EXCAVATION AS REQUIRED.					
390	L.P. EXCAVATION CQP-300 REV 10	L.P. ALL EXCAVATIONS PRIOR TO WELDING TO ENSURE REMOVAL OF DEFECT. ACCEPTANCE PER A903. IF OK CHECK HERE _____ IF REJECTED SEND BACK TO STEP 385.			LP - LEVEL II		

NA

**Energy Industries of Ohio
Manufacturing and Test Sequence (MTS) Serial Number C-5 Coil**

8 OF 11 CO# 40851 Dated 3-9-05 Revision: Rev 8 Dated Issued:7-29-05

N4

400	WELD MAP	MAP ALL MAJOR WELDS WITH DIGITAL PHOTO/MAPS INDICATING LOCATION. SERIALIZE DEFECTS ON CASTING, USE SCALE IN PHOTOS AND DOCUMENT SIZE. THIS IS TO BE PERFORMED BY SUPERVISOR, INSPECTION LEAD MAN OR THEIR DESIGNEE, FILE WITH QA. USE YELLOW MARKER. MUST INDICATE ON MAP ALL MAJOR WELDS, DEFINED AS GREATER THAN 20% OF THE WALL OR 1 INCH WHICHEVER IS LESS OR 10 SQUARE INCHES APPROXIMATLY 3.3"X3.3".		
420	QA APPROVAL HOLD POINT	QA TO APPROVE ELECTRODE PRIOR TO USE. PROCEDURE USED: _____ MATERIAL/LOT USED: _____ QUALITY ENG. Name: _____ Date: _____		
430	WELD SOP 0100 REV 7	WELD REPAIR DEFECTS AS MARKED. FOR WELDS <2" - WPS 10-SMAW-CF8MNMN MOD REV 1(Flat) or 25 SMAW-CF8MNMN MOD REV 0 (Vertical) FOR WELDS <8" - WPS 15-GMAW-CF8MNMN MOD REV 2		
440	GRIND GCHI SOP 0100 REV 2	HAND GRIND WELDS.		
450	L.P. WELDS CQP 0300 REV 10	L.P. WELD REPAIRS ACCEPTANCE PER ASTM A903. IF OK CHECK HERE _____ WASH AND SEND TO STEP 460. IF REJECTED CHECK HERE _____ AND RETURN TO STEP 440.	LP - LEVEL II	
	REPEAT	REPEAT STEPS 350 TO 450 AS REQUIRED TILL WELDS CLEAR FINAL LIQUID PENETRANT INSPECTION. DOCUMENT REWORK ON A SUPPLEMENTAL MTS	QA ENG.	
451	TEST MAG PERM SOP MAG PERM 100, REV 1	TEST MAG PERMEABILITY REPAIR AREAS. RECORD ON WELD MAP LIST. TEST AT LEAST 5 POINTS PER WELD. ACCEPTANCE 1.02. IF OK CHECK HERE _____ AND GO TO STEP 430. IF REJECTED CHECK HERE _____.		
452	GRIND GCHI SOP 0100R2	GRIND AREAS OF NON COMPLIANCE AND RETURN TO STEP 451. REPEAT UNTIL COMPLIANCE IS ACHIEVED.		
455	HEAT TREAT	STRESS RELIEF. Load casting into cold furnace. Ramp up to 1100 F at rate of 200 F per hour. Hold at temp 4 hours. Furnace cool to 500 F at 50 F per hour. Air cool. Submit furnace charts to QA.	KMR	11/14/05
NOTICE	WITNESS NOTIFICATION	PROVIDE NOTICE TO EIO AND DCMA AT LEAST FIVE DAYS IN ADVANCE OF VISUAL AND LP STEPS. EIO NOTIFIED ON 11/7 DCMA NOTIFIED ON 11/7	Q ENG OR QA MGR	Ctr

↓

*This is a replacement
 MTS. Original was
 stamped and can't be copied*

460	FINAL VISUAL INSPECTION CQP-500 REV 4	VISUALLY INSPECT 100% of COMPONENT ACCORDING TO ASTM A802 LEVEL 3 ALL CONDITIONS. IF OK CHECK HERE _____ IF REJECTED CHECK HERE <u>✓</u> . MARK AND REPAIR AT STEP 390. MUST BE PERFORMED BY LEVEL II in VT.	VT - LEVEL II JDR	11/15	DCMA stamp
470	FINAL L.P. CQP 0300 REV 10	FINAL L.P. 100% OF COMPONENT. ACCEPTANCE PER ASTM A903. ACCEPTANCE CRITERIA-LEVEL 1 FOR HIGH STRESSED AREAS, LEVEL 2 FOR ALL OTHER AREAS. SEE LP DRAWING. IF OK CHECK HERE _____ WASH AND SEND TO STEP 455. IF REJECTED CHECK HERE <u>✓</u> . DOCUMENT REPAIRS USING S321 THROUGH S327.	LP - LEVEL II JDR	11/15	DCMA stamp
NOTICE	WITNESS NOTIFICATION	PROVIDE NOTICE TO EIO AND DCMA AT LEAST FIVE DAYS IN ADVANCE OF MAG PERM STEPS. EIO NOTIFIED ON <u>11/7</u> DCMA NOTIFIED ON <u>11/7</u>	Q ENG OR QA MGR		Ctr
500	FINAL MAG PERM INSPECTION SOP MAG PERM 100, REV 1	PERFORM MAG PERM TESTING WITH SEVRIN GAUGE. ACCEPTANCE 1.02. CHECK THE ENTIRE SURFACE ON A 6"BY6" GRID. REPORT RESULTS. USE A 6" SQUARE BLOCK TO INDICATE TEST LOCATIONS AND RECORD RESULTS. COMPLIANT AREAS WILL NOT BE MARKED. MARK NONCOMPLIANT AREAS WITH AN "X" FOR REPAIR. OK CHECK HERE _____ AND GO TO STEP 530. IF REJECTED CHECK HERE _____	TRC	11/17/05	
510	GRIND GCHI SOP 0100 REV 2	HAND GRIND WITH SUITABLE CONE OR OTHER SIMILAR GRINDER AS REQUIRED TO ENSURE REMOVAL OF MATERIAL TO ACHIEVE MAG PERM REQUIREMENT. CIRCLE AREA REMEDIATE FOR RETEST.	MA		
520	RETEST MAG PERM SOP MAG PERM 100, REV 1	RETEST MAG PERMEABILITY AT FAILED TEST POINTS. MARK NONCOMPLIANT AREAS WITH AN "X" FOR REPAIR. ACCEPTANCE 1.02. IF OK CHECK HERE _____ . IF REJECTED CHECK HERE _____ RETURN TO STEP 510.			
530	DOC. REVIEW	REVIEW DOCUMENTS AS REQUIRED IN CAF CHECKLIST, ALL DOCUMENTS NOTED TO BE ACCESSIBLE FOR AUDITING. (SHIPPER, C OF C, M.T.R., M.T.S., INSPECTION REPORT, X-RAY READER SHEETS AND HEAT TREAT CHARTS)	Ctr	11/17/05	
NOTICE	RELEASE FROM EIO	PROVIDE DOCUMENTS TO EIO. SENT ON <u>11/21</u> BY <u>Ctr</u> . RECEIVED RELEASE FROM EIO ON _____.	Q ENG OR QA MGR		Ctr
540	PACK AND SHIP	PACKAGE AND SHIP TO MAJOR TOOL.			
1000	REVISION HISTORY	ORIGINAL 12-14-04. Approved 12-14-04. Revision level 1- Revised 1-26-05 new page 8, correct High stress areas, Revision level 2 3-16-05, delete LO step 455. Revision 3 3-28-05 Added note regarding hold point at weld step 400. Revision level 4 written for C-2 casting 4-18-05. Rev 5 added Layout SOP# and note regarding first casting layout responsibility. 5-10-05. Rev 6 added word LOT to weld material steps. 5-29-05. Rev 7 6-14-05 added "LOT" to weld step on supplement page. Rev. 8 7-29-05 added stress relief, deleted weld hold points, added vertical weld procedure, and several editorial changes.	CARUUD		

*original on file
 at CAF. Ctr*



GENERAL ISOMETRIC
VIEW FROM TOP SIDE

**TABS DESIGNATE
CRITICAL AREA**

RED AREA INDICATES HIGH STRESSED AREA

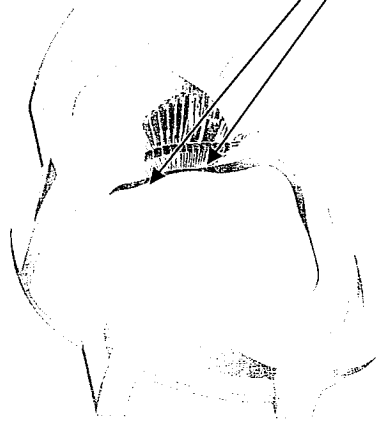

TOP SIDE ISOMETRIC

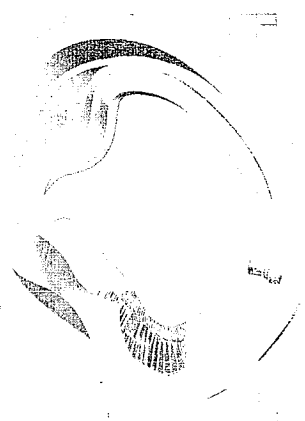

TOP SIDE VIEW

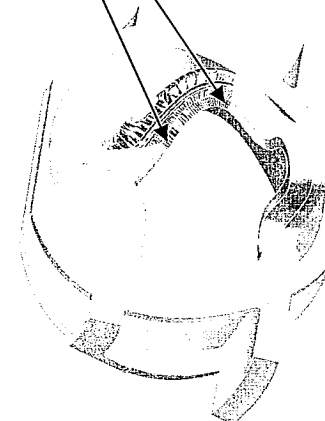

BOTTOM SIDE ISOMETRIC

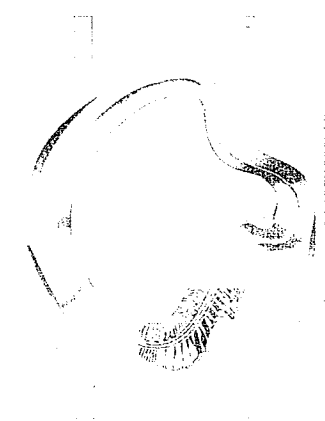

BOTTOM SIDE VIEW

Energy Industries of Ohio

Manufacturing and Test Sequence (MTS) Serial Number C-5 Coil

11 OF 11

CO# 40851

Dated 3-9-05

Revision: Rev 8

Dated Issued:7-29-05

Energy Industries of Ohio

Manufacturing and Test Sequence (MTS) Coill C Shim

FIVE PARTS KEEP TOGETHER

CO# 40851, Pattern SE 141-073 -5 MS73220-2 Dated December 14, 2004 Revision: Original

Page 1 of 6

Dated Issued: 4-27-05

OPER. #	STATION	DESCRIPTION OF PROCESS	Name	Date
		Keep all parts together. Sign and date each step when all 5 parts have been completed.		
10	QUALITY RELEASE	REVIEW AND APPROVE MTS. RECEIVED APPROVAL FROM EIO ON <u>Pete</u> FROM <u>12/15</u>	<u>CR</u>	<u>4/21/05</u>
20	PATTERN NPAT SOP 0100REV2	APPLY APPROPRIATE PART NUMBER, SERIAL NUMBER, FOUNDRY MARK, TO THE PATTERN.	<u>TB</u>	<u>4/22/05</u>
30	MOLD MOLD SOP 0400 REV 8 CALIBRATION PER MOLD SOP 0900 REV 5 PREPARATION PER MOLD SOP 1100R2/1200R2/1300R1 SAND TESTING PER MOLD SOP 1400R2/1500R3/1600R2	MOLD PER WORK INSTRUCTIONS IN MAPICS ROUTING AND SOPS REFERENCED. ENGINEER OF RECORD - ROGER BROMAN, CONSULT ON MOLD-RELATED CONCERNS. MOLD MATERIALS REQUIRED PER MAPICS BOM. NOTIFY ENGINEER OF ANY SUBSTITUTIONS.	<u>CR</u>	<u>4/22</u>
40	POUR MELT SOP 0100R5 MELT SOP 0700R2 MELT SOP 0600R2	METAL MUST BE AOD REFINED OR AOD INGOT. VIRGIN METAL ADDITIONS ALLOWED. RECORD POURING TEMPERATURE: <u>2825</u> CASTING POURED AT: <u>1245 AM</u> DATE: <u>4/28</u> HEAT #'s: <u>29198</u> ELAPSED POUR TIME <u>WA</u> KEEL BLOCKS POURED: <u>YES</u> Sample from ladle to be analyzed for final chemical analysis and reported on material certifications. Sample Taken by: <u>SR</u> Analyzed: <u>GH</u> Date: <u>4/28</u> Note: Make 15 additional test bars for mechanical testing.	<u>JG</u>	<u>4/28/05</u>
50	MELT SOP 0800R2	SHAKEOUT	<u>CA</u>	<u>4/29/05</u>
60	ARC RISE SOP 0100R1	REMOVE RISERS AS DIRECTED BY SUPERVISOR.	<u>BNVH</u>	<u>6/16/05</u>
70	HEAT TREAT HEAT SOP 0103R5	SOLUTION ANNEAL. With C-1 Coil.	<u>DLS</u>	<u>6/2/05</u>

Energy Industries of Ohio

Manufacturing and Test Sequence (MTS) Coill C Shim

FIVE PARTS KEEP TOGETHER

CO# 40851, Pattern SE 141-073 -5 MS73220-2 Dated December 14, 2004 Revision:Original

Page 2 of 6

Dated Issued:4-27-05

80	PHYSICAL TESTING	OBTAIN TEST SPECIMENS AND SUBMIT FOR PHYSICAL TESTING. REPORT RESULTS AS PART OF STEP 480.	NA	
90	GRIND GSWA SOP 0100R3 GCHI SOP 0100R2	SWING GRIND TO REMOVE RISER REMAINS AND FLASH IF REQUIRED. CHIP AND HAD GRIND SURFACE OF PART AS REQUIRED.	CEG * 6-16-05	
100	SAND BLAST BLAS SOP 0100R6	SANDBLAST (REMOVE ALL BLAST MATERIAL FROM CASTING) SANDBLASTING WILL BE DONE USING RECYCLED SHARP ANGULAR AGGREGATE.	CAZ	4/17
110	VISUAL INSPECTION CQP-500 REV 4	VISUALLY INSPECT 100% of COMPONENT ACCORDING TO ASTM A802 LEVEL 3 ALL CONDITIONS. IF OK CHECK HERE _____. IF REJECTED CHECK HERE _____. MARK AND REPAIR AT STEP 130.	VT - LEVEL II	see # 322
NOTICE	WITNESS NOTIFICATION	PROVIDE NOTICE TO EIO AND DCMA AT LEAST FIVE DAYS IN ADVANCE OF LP STEP. EIO NOTIFIED ON <u>11/1</u> DCMA NOTIFIED ON <u>11/1</u>	Q ENG OR QA MGR	CAZ
120	100% L.P. CQP 0300 REV 10	L.P. 100% OF COMPONENT. ACCEPTANCE PER ASTM A903. ACCEPTANCE CRITERIA- LEVEL 2. IF OK CHECK HERE _____. IF REJECTED CHECK HERE _____. MARK AND REPAIR AT STEP 120.	LP - LEVEL II	NA
130	WELD SOP 0100 REV 7	EXCAVATE ANY DEFECTS FOUND DURING 100% VISUAL AND LP INSPECTION.		
140	L.P. EXCAVATION CQP-300 REV 10	L.P. ALL EXCAVATIONS PRIOR TO WELDING TO ENSURE REMOVAL OF DEFECT. ACCEPTANCE PER A903. ACCEPTANCE CRITERIA- LEVEL 2.	LP - LEVEL II	
150	SAND BLAST BLAS SOP 0100R6	SANDBLAST (REMOVE ALL BLAST MATERIAL FROM CASTING) SANDBLASTING WILL BE DONE USING RECYCLED SHARP ANGULAR AGGREGATE.		
160	WELD MAP	MAP ALL WELDS WITH DIGITAL PHOTO/MAPS. SERIALIZE DEFECTS ON CASTING, USE SCALE IN PHOTOS AND DOCUMENT SIZE. THIS IS TO BE PERFORMED BY SUPERVISOR, INSPECTION LEAD MAN OR THEIR DESIGNEE, FILE WITH QA.. USE YELLOW MARKER. MUST SEND REPORT ON ALL WELDS OVER 10% OF NOMINAL WALL THICKNESS TO CUSTOMER. DEFECTS > 10% YES _____, REPORT SENT BY _____ DATE _____ DEFECTS < 10 % _____ SIGN BY QA ENG.		
NOTICE	WITNESS NOTIFICATION	PROVIDE NOTICE TO EIO AND DCMA AT LEAST FIVE DAYS IN ADVANCE OF XRAY AND LAYOUT STEPS. EIO NOTIFIED ON <u>11/1</u> DCMA NOTIFIED ON <u>11/1</u>	Q ENG OR QA MGR	CAZ

Energy Industries of Ohio

FIVE PARTS KEEP TOGETHER

Manufacturing and Test Sequence (MTS) Coill C Shim

CO# 40851, Pattern SE 141-073 -5 MS73220-2 Dated December 14, 2004 Revision:Original

Page 3 of 6

Dated Issued:4-27-05

170	CAF X-RAY CQP 401 REV 5	X-RAY PER TECHNIQUE: To be determined. USE CALIBRATED DENSITOMETER FOR DENSITY VERIFICATION. ATTACH TECHNIQUE, READER SHEET FOR ALL RADIOGRAPHS. MUST INDICATE RADIOGRAPHER AND ASNT CERTIFICATION LEVEL ON READER SHEET.	RT - LEVEL II RBK 11-8-05
180	X-RAY CQP 401 REV 5	X-RAY INTERPRETATION. ACCEPTANCE MSS SP 54. ATTACH TECHNIQUE, READER SHEET FOR ALL RADIOGRAPHS. MUST INDICATE RADIOGRAPHER AND ASNT CERTIFICATION LEVEL ON READER SHEET. IF OK CHECK HERE <input checked="" type="checkbox"/> AND SEND TO STEP 310. REJECTED CHECK HERE <input type="checkbox"/> MARK UP DEFECTS AND SEND THE CASTING TO STEP 200..	RT - LEVEL II RBK 11-8-05
190	LAYOUT	INSPECT CASTING TO VERIFY DIMENSIONS. THIS MAY BE PERFORMED BEFORE OR AFTER STEP 180. DIMENSIONED <u>Done J</u> DATE <u>9-10-05</u> RELEASED _____ (ENGINEER ONLY)	JJ 9-12-05
200	WELD SOP 0100 REV 7	EXCAVATE ANY DEFECTS FOUND DURING RADIOGRAPHY.	
210	L.P. EXCAVATION CQP-300 REV 10	L.P. ALL EXCAVATIONS PRIOR TO WELDING TO ENSURE REMOVAL OF DEFECT. ACCEPTANCE PER A903. ACCEPTANCE CRITERIA- LEVEL 2.	LP - LEVEL II JPS 11-15-05
220	WELD MAP	MAP ALL WELDS WITH DIGITAL PHOTO/MAPS. SERIALIZE DEFECTS ON CASTING, USE SCALE IN PHOTOS AND DOCUMENT SIZE. THIS IS TO BE PERFORMED BY SUPERVISOR, INSPECTION LEAD MAN OR THEIR DESIGNEE, FILE WITH QA.. MUST SEND REPORT ON ALL WELDS OVER 10% OF NOMINAL WALL THICKNESS TO CUSTOMER. DEFECTS>10% YES _____, REPORT SENT BY _____ DATE _____ DEFECTS < 10 % _____ SIGN BY QA ENG.	NA
NOTICE	WITNESS NOTIFICATION	PROVIDE NOTICE TO EIO AND DCMA AT LEAST FIVE DAYS IN ADVANCE OF WELD STEP. EIO NOTIFIED ON _____ DCMA NOTIFIED ON _____	Q ENG OR QA MGR
230	QA APPROVAL HOLD POINT	QA TO APPROVE ELECTRODE PRIOR TO USE. PROCEDURE USED: _____ MATERIAL USED: _____ QUALITY ENG. Name: _____ Date: _____	
240	WELD SOP 0100 REV 7	WELD REPAIR DEFECTS AS MARKED. FOR WELDS <2" - WPS 10-SMAW-CF8MNMN MOD REV 1 FOR WELDS <8" - WPS 15-GMAW-CF8MNMN MOD REV 2	
250	GRIND GCHI SOP 0100R2	HAND GRIND WELDS.	

See
Final
on #330

Energy Industries of Ohio

Manufacturing and Test Sequence (MTS) Coill C Shim

FIVE PARTS KEEP TOGETHER

CO# 40851, Pattern SE 141-073 -5 MS73220-2 Dated December 14, 2004 Revision:Original

Page 4 of 6

Dated Issued:4-27-05

260	L.P. WELD CQP 0300 REV 10	L.P. WELD REPAIRS ACCEPTANCE PER ASTM A903. ACCEPTANCE CRITERIA-LEVEL 2. IF OK CHECK HERE _____ WASH AND SEND TO STEP 300. IF REJECTED CHECK HERE _____ AND RETURN TO STEP 220.	LP - LEVEL II	NA
	REPEAT	REPEAT STEPS 220 TO 260 AS REQUIRED TILL CLEAR THROUGH VISUAL INSPECTION & PENETRANT INSPECTION. DOCUMENT REWORK ON A SUPPLEMENTAL MTS	QA ENG.	
270	TEST MAG PERM SOP MAG PERM 100, REV 1	TEST MAG PERMEABILITY REPAIR AREAS RECORD ON WELD MAP LIST. TEST AT LEAST 5 POINTS PER WELD. ACCEPTANCE 1.02. IF OK CHECK HERE _____ AND GO TO STEP 290. IF REJECTED CHECK HERE _____.		
280	GRIND GCHI SOP 0100R2	GRIND AREAS OF NON COMPLIANCE AND RETURN TO STEP 270. REPEAT UNTILL COMPLIANCE IS ACHIEVED.		
290	CAF X-RAY DEFECTS REPAIRED BY WELDING CQP 401 REV 5	X-RAY PER TECHNIQUE: To be determined. USE CALIBRATED DENSITOMETER FOR DENSITY VERIFICATION. ATTACH TECHNIQUE, READER SHEET FOR ALL RADIOGRAPHS. MUST INDICATE RADIOGRAPHER AND ASNT CERTIFICATION LEVEL ON READER SHEET.	RT - LEVEL II	
300	X-RAY CQP 401 REV 5	X-RAY INTERPRETATION. ACCEPTANCE MSS SP 54. ATTACH TECHNIQUE, READER SHEET FOR ALL RADIOGRAPHS. MUST INDICATE RADIOGRAPHER AND ASNT CERTIFICATION LEVEL ON READER SHEET. IF OK CHECK HERE _____ AND SEND TO STEP 310. REJECTED CHECK HERE _____ MARK UP DEFECTS AND SEND THE CASTING TO STEP 200.	RT - LEVEL II	
	REPEAT	REPEAT STEPS 200 TO 300 AS REQUIRED TILL WELDS CLEAR X-RAY. DOCUMENT REWORK ON A SUPPLEMENTAL MTS	QA ENG.	
310	SAND BLAST BLAS SOP 0100R6	SANDBLAST (REMOVE ALL BLAST MATERIAL FROM CASTING) SANDBLASTING WILL BE DONE USING RECYCLED SHARP ANGULAR AGGREGATE.		
NOTICE	WITNESS NOTIFICATION	PROVIDE NOTICE TO EIO AND DCMA AT LEAST FIVE DAYS IN ADVANCE OF VISUAL AND LP STEPS. EIO NOTIFIED ON <u>11/7</u> DCMA NOTIFIED ON <u>11/7</u>	Q ENG OR QA MGR	ctz
320	FINAL VISUAL INSPECTION CQP-500 REV 4	VISUALLY INSPECT 100% of COMPONENT ACCORDING TO ASTM A802 LEVEL 2 ALL CONDITIONS. IF OK CHECK HERE <input checked="" type="checkbox"/> . IF REJECTED CHECK HERE _____ . MARK AND REPAIR AT STEP 340.	VT - LEVEL II JR	11/15/05

Energy Industries of Ohio

Manufacturing and Test Sequence (MTS) Coill C Shim

FIVE PARTS KEEP TOGETHER

CO# 40851, Pattern SE 141-073 -5 MS73220-2 Dated December 14, 2004 Revision:Original

Page 5 of 6

Dated Issued:4-27-05

		MUST BE PERFORMED BY LEVEL II in VT.		
330	FINAL L.P. CQP 0300 REV 10	FINAL L.P. 100% OF COMPONENT. ACCEPTANCE PER ASTM A903. ACCEPTANCE CRITERIA- LEVEL 1 FOR HIGH STRESSED AREAS, LEVEL 2 FOR ALL OTHER AREAS. SEE LP DRAWING. IF OK CHECK HERE <input checked="" type="checkbox"/> WASH AND SEND TO STEP 410. IF REJECTED CHECK HERE <input type="checkbox"/>	LP - LEVEL II	JPS 11/05/05
340	WELD SOP 0100 REV 7	EXCAVATE ANY DEFECTS FOUND DURING FINAL PENETRANT INSPECTION.	NA	
350	L.P. EXCAVATION CQP-300 REV 10	L.P. ALL EXCAVATIONS PRIOR TO WELDING TO ENSURE REMOVAL OF DEFECT. ACCEPTANCE PER A903.	LP - LEVEL II	
370	WELD MAP	MAP ALL WELDS WITH DIGITAL PHOTO/MAPS. SERIALIZE DEFECTS ON CASTING, USE SCALE IN PHOTOS AND DOCUMENT SIZE. THIS IS TO BE PERFORMED BY SUPERVISOR, INSPECTION LEAD MAN OR THEIR DESIGNEE. FILE WITH QA. MUST SEND REPORT ON ALL WELDS OVER 10% OF NOMINAL WALL THICKNESS TO CUSTOMER. NOMINAL WALL THICKNESS TO CUSTOMER. DEFECTS >10% YES _____, REPORT SENT BY _____ DATE _____ DEFECTS < 10 % _____ SIGN BY QA ENG.		
380	WELD SOP 0100 REV 7	WELD REPAIR DEFECTS AS MARKED. FOR WELDS <2" - WPS 10-SMAW-CF8MNMN MOD REV 1 FOR WELDS <8" - WPS 15-GMAW-CF8MNMN MOD REV 2		
390	GRIND GCHI SOP 0100 REV 2	HAND GRIND WELDS.		
400	L.P. WELDS CQP 0300 REV 10	L.P. WELD REPAIRS ACCEPTANCE PER ASTM A903. IF OK CHECK HERE _____ WASH AND SEND TO STEP 460. IF REJECTED CHECK HERE _____ AND RETURN TO STEP 390.	LP - LEVEL II	
	REPEAT	REPEAT STEPS 390 TO 410 AS REQUIRED TILL WELDS CLEAR FINAL LIQUID PENETRANT INSPECTION. DOCUMENT REWORK ON A SUPPLEMENTAL MTS	QA ENG.	
410	TEST MAG PERM SOP MAG PERM 100, REV 1	TEST MAG PERMEABILITY REPAIR AREAS. RECORD ON WELD MAP LIST. TEST AT LEAST 5 POINTS PER WELD. ACCEPTANCE 1.02. IF OK CHECK HERE _____ AND GO TO STEP 430.		

Energy Industries of Ohio

FIVE PARTS KEEP TOGETHER

Manufacturing and Test Sequence (MTS) Coill C Shim

CO# 40851, Pattern SE 141-073 -5 MS73220-2 Dated December 14, 2004 Revision:Original

Page 6 of 6

Dated Issued:4-27-05

420	GRIND GCHI SOP 0100R2	GRIND AREAS OF NON COMPLIANCE AND RETURN TO STEP 420. REPEAT UNTILL COMPLIANCE IS ACHIEVED.	NA ↓	
NOTICE	WITNESS NOTIFICATION	PROVIDE NOTICE TO EIOAND DCMA AT LEAST FIVE DAYS IN ADVANCE OF MAG PERM STEP. EIO NOTIFIED ON <u>11/1</u> DCMA NOTIFIED ON <u>11/1</u>	Q ENG OR QA MGR	<i>CAZ</i>
430	FINAL MAG PERM INSPECTION SOP MAG PERM 100, REV 1	PERFORM MAG PERM TESTING WITH SEVRIN GAUGE. ACCEPTANCE 1.02. CHECK THE ENTIRE SURFACE ON A 6"BY6" GRID. REPORT RESULTS. USE A 6" SQUARE BLOCK TO INDICATE TEST LOCATIONS AND RECORD RESULTS. COMPLIANT AREAS WILL NOT BE MARKED. MARK NONCOMPLIANT AREAS WITH AN "X" FOR REPAIR. OK CHECK HERE <input checked="" type="checkbox"/> AND GO TO STEP 470. IF REJECTED CHECK HERE	RG	11/16
440	GRIND GCHI SOP 0100 REV 2	HAND GRIND WITH SUITABLE CONE OR OTHER SIMILAR GRINDER AS REQUIRED TO ENSURE REMOVAL OF MATERIAL TO ACHIEVE MAG PERM REQUIREMENT. CIRCLE AREA REMEDIATE FOR RETEST.	NA	
450	RETEST MAG PERM SOP MAG PERM 100, REV 1	RETEST MAG PERMEABILITY AT FAILED TEST POINTS. MARK NONCOMPLIANT AREAS WITH AN "X" FOR REPAIR. ACCEPTANCE 1.02. IF OK CHECK HERE . IF REJECTED CHECK HERE RETURN TO STEP 450		
460	PHOTOGRAPH	TAKE DIGITAL PICTURES.		
470	AUDIT REVIEW	PROCESS DOCUMENT TO PROGRAM MANAGER FOR COMPLIANCE AUDIT.	<i>CAZ</i>	11/17/05
480	DOC. REVIEW	REVIEW DOCUMENTS AS REQUIRED IN CAF CHECKLIST, ALL DOCUMENTS NOTED TO BE ACCESSIBLE FOR AUDITING. (SHIPPER, C OF C, M.T.R., M.T.S., INSPECTION REPORT, X-RAY READER SHEETS AND HEAT TREAT CHARTS)	<i>CAZ</i>	11/17/05
NOTICE	RELEASE FROM EIO	PROVIDE DOCUMENTS TO EIO. SENT ON <u>11/21/05</u> BY <u><i>CAZ</i></u> . RECEIVED RELEASE FROM EIO ON _____	Q ENG OR QA MGR	<i>CAZ</i>
490	PACK AND SHIP	PACKAGE AND SHIP TO MAJOR TOOL.		
1000	REVISION HISTORY	ORIGINAL 12-14-04.	CARUUD	



Corrective Action 1308
Carondelet Division - CA / PA / RGA Database
Corrective Action Type NCR
Date 6/13/2005
CA Originator C. Ruud
Pattern Number: C and A Coil Shims 11 Pieces

Description of Defect / Non-Conformance

Chemistry for 11 shim castings is out of specification.

Root Cause

Chemistry specification was not changed in system and not communicated to Lab personnel.

Corrective Action

Specification was corrected in system and Lab personnel trained. Mag permeability was checked on the parts and are less than 1.02u.

Verification of Corrective Action

Chemistries were checked on subsequent parts and are within specification.

Preventive Action

Create Inspection and Test Plan summarizing all requirements.

Estimated Completion Date

6/15/05

Actual Completion Date

Complete.

A handwritten signature in black ink, appearing to read "C. Ruud".

Signed: C. Ruud

CC: Roger Broman, Barry Craig, Joe Edwards, E.J. Kubick

Nonconformance Report: MetalTek CA 1308

Project Disposition: Use as is.

Approvals

Procurement Technical Representative _____
Wayne Reiersen for Phil Heitzenroeder

Responsible Line Manager _____
Mike Cole for Brad Nelson

Nonconformance Report: CA 1323 (phosphorus levels exceeds specification limits for castings C1- C4 and A1 and C1 shim and four Type C and six A coil shims)

Project Disposition:

The erroneous levels were due to calibration errors with the spectrometer. As reported in MTK's attached report, preventive maintenance has since been performed on the spectrometer. The reported chemistry will be accepted for the castings and shims noted above. The specification chemistry will not be changed at this time.

Approvals:

**Phil
Heitzenroeder**

Digitally signed by Phil Heitzenroeder
DN: CN = Phil Heitzenroeder, C = US,
O = PPPL, OU = Mech. Eng. Division
Reason: I agree to 'specified' portions
of this document
Date: 2006.02.21 11:49:56 -05'00'

Procurement Technical Representative

**Brad
Nelson**

Digitally signed by Brad Nelson
DN: cn=Brad Nelson, c=US,
o=ORNL, ou=FED,
email=nelsonbe@ornl.gov
Date: 2006.02.21 14:16:12
-05'00'

Responsible Line Manager:



Corrective Action 1323
Carondelet Division - CA / PA / RGA Database
Corrective Action Type NCR
Date 7/27/2005
CA Originator C. Ruud
Applies to: Coil castings C-1, C-2, C-3, C-4 and A-1 and C 1 shim and four C coil and six A coil shims

Description of Defect / Non-Conformance

Phosphorus levels in material produced to date exceed specification limits. Both phosphorus and sulfur readings reported erroneously in certifications.

Certification reports have shown phosphorus and sulfur levels in the <.01% range. Independent laboratory data confirmed phosphorus in the .018 to .033% range and sulfur in the .005 to .022% range. Actual levels of some tests are above those in PPPL Specification NCSX-CSPEC-141-03-07 Rev 7.

Nonconformance was first suspected as a result of analysis of zoned attached test specimens volunteered by MetalTek International as response to PPPL questions on weighted average chemical analysis and quality of blending in the gating system. Nonconformance was verified on the bars used in the study and has been extended to evaluation of previously poured products.

Root Cause

Specification limits were set below the levels achievable through use of available raw materials. Spectrometer did not properly calibrate for phosphorus and sulfur at levels of specification due to equipment malfunction.

The chemical specification of EIO heats uses alloy CF8MNMn-Mod which incorporates a type standard calibration with a certified reference material (CRM) BS180. This enables the operator of the spectrometer to match the elemental concentrations of this alloy with corrective factors. These factors are determined by analyzing the CRM and having them compared with the calibration curves for each element. The phosphorus and sulfur content have very low measured intensities due to low concentrations. Intermittent failure of the spectrometer intensity measuring card caused higher intensity readings for phosphorus and sulfur. Subsequent checks with the CRM resulted in low corrective factors that were not detected. This in turn resulted in low reported concentrations for the EIO samples. All the major elements, which are measured on other intensity cards, have been closely monitored and matched very well with the CRM and thus were reported correctly.

Corrective Action

Modification to specification for phosphorus and sulfur will be requested. Limits will be set based on process capability and consistent with other stainless steel grades. Replacement of deficient card in spectrometer will be made upon delivery.

Subsequent immediate analysis of chemistry results, obtained by wet analysis, is attached and demonstrate top of specification for sulfur and over specification for phosphorus. The spectrometer manufacturer has performed an analysis to determine the cause of the malfunction and verified that the intensity card has an intermittent fault and must be replaced. The card has been ordered and scheduled for replacement on August 15, 2005.

Until the card is replaced we will be performing additional type standardizations to ensure accurate sulfur and phosphorus analysis. Additionally, for coils made until the card is replaced, an independent laboratory will perform a verification of the chemical analysis.

Verification of Corrective Action

Will be determined at a later date.

Preventive Action

In addition to spectrometer faults, we have identified that the specification ranges for sulfur and phosphorus is unattainable. Analysis and specifications for virgin charge materials predict sulfur at 0.040% maximum and phosphorus at 0.040% maximum. We have no way to remove phosphorus from the melt and do not intentionally add phosphorus. So, the confirmed coil analyses, along with analyses of virgin material heats, demonstrate sulfur in the range of 0.010% to 0.022% and phosphorus in the range of 0.018% to 0.033%. These results are consistent with our charge material analysis. We will request a deviation for phosphorus in the subject parts and also request a permanent specification change to 0.040% maximum for both phosphorus and sulfur, to allow us to provide non-discrepant material. This change will not affect, in any way, the physical properties or material performance because all coils and test material exhibited sulfur and phosphorus within the new ranges despite inaccurate reporting. Other actions: Specifications have been added to the BS 180 standard and the type standard will be measured against the criteria.

Estimated Completion Date

August 15, 2005

Actual Completion Date TBD

Signed: C. Ruud



CC: Jim Galaske, Barry Craig, Joe Edwards, E.J. Kubick

Guide to St Louis Testing Report Dated 7-26-05

Sample name	Sample origin
A1Z1	Cast on bar A-1 coil, zone 1
A1Z2	Cast on bar A-1 coil, zone 2
A1Z3	Cast on bar A-1 coil, zone 3
C1	Cast on bar C-1 coil
C2Z1	Cast on bar C-2 coil, zone 1
C2Z2	Cast on bar C-2 coil, zone 2
C2Z3	Cast on bar C-2 coil, zone 3
C3Z1	Cast on bar C-3 coil, zone 1
C3Z2	Cast on bar C-3 coil, zone 2
C3Z3	Cast on bar C-3 coil, zone 3
F1	Final analysis button from ladle for C-4 coil
F2	Final analysis button from ladle for C-4 coil
F3	Final analysis button from ladle for C-4 coil
P1	Preliminary analysis button from ladle for C-4 coil

Testing is underway of the heat used to pour the four C coil and six A coil shims.

*Attachment to
CA 1323*



Chemical, Metallurgical, Mechanical, Nondestructive, Environmental Testing, Analyses and Field Service.

July 26, 2005
Lab No. 05C-0608
Invoice No. 59891
P.O. No. 21324
Page 1 of 1

METALTEK INTERNATIONAL
8600 Commercial Blvd.
Pevely, MO 63070

Attention: Chuck Ruud

REPORT OF CHEMICAL ANALYSIS

SAMPLE ID: A1 Z1, A1 Z2, A1 Z3, C1, C2 Z1, C2 Z2, C2 Z3,
C3 Z1, C3 Z2, C3 Z3, F1, F2, F3, P1

RESULTS: %

ANALYTE	A1Z1	A1Z2	A1Z3
Sulfur	.013	.005	.010
Phosphorus	.025	.023	.018

ANALYTE	C1	C2Z1	C2Z2	C2Z3
Sulfur	.014	.022	.018	.015
Phosphorus	.018	.024	.021	.025

ANALYTE	C3Z1	C3Z2	C3Z3
Sulfur	.013	.014	.012
Phosphorus	.024	.025	.021

ANALYTE	F1	F2	F3	P1
Sulfur	.014	.015	.012	.010
Phosphorus	.029	.033	.028	.030

Sulfur Test Method: ASTM E1019-03

Phosphorous Test Method: Colormetric

Identification of tested specimen provided by the client.

Robin E. Sinn
Laboratory Director



RES/nmc



Corrective Action 1379
Carondelet Division - CA / PA / RGA Database
Corrective Action Type NCR
Date 8/31/2005
CA Originator C. Ruud
Applies to: Weld Material Lincoln 3018926-78309

Description of Defect / Non-Conformance

Material failed elongation and one of three Charpy impact tests at -320 F. The average of the specimens exceeds the minimum. See S8 of ASTM A 703/A 703M.

Root Cause

The sample of the weld contained defects not detected.

Corrective Action

Retest material already at Lab.

If needed, make a new weld plate after reviewing process with welder and weld another sample.

Verification of Corrective Action

Retest results. If new plates are needed, the new plate will be x-rayed prior to testing.

Estimated Completion Date

9-2-05

Actual Completion Date TBD

Signed: C. Ruud

A handwritten signature in black ink, appearing to be "C. Ruud".

CC: R. Suria, Barry Craig, Joe Edwards, E.J. Kubick

Nonconformance Report: CA1379

Project Disposition:

Since the re-test meets requirements, this NCR can now be considered closed.

Approvals:

Phil
Heitzenroeder

Digitally signed by Phil Heitzenroeder
DN: CN = Phil Heitzenroeder, C = US,
O = PPPL, OU = Mech. Eng. Division
Reason: I am approving this document
Date: 2005.11.07 10:09:53 -0500

Procurement Technical Representative

 11/7/05

Responsible Line Manager:



Corrective Action 1454
Carondelet Division - CA / PA / RGA Database
Corrective Action Type NCR
Date 11/18/2005
CA Originator C. Ruud
Applies to: C-5 Coil casting

Description of Defect / Non-Conformance

Zone 1 Tensile test at 77K failed elongation at 31% compared to the specification minimum of 32%. A retest also failed at 29%. All other properties exceeded the specification of NCSX-CSPEC-141-03-09. See attached summary of room temperature and cryogenic test results.

Root Cause

Zone 1 test samples have solidified with much less superheat than the other zones as a result of their relative orientation in the mold and mold filling. Zone 1 test bars are in the bottom of the drag, zone 2 and 3 are much higher in the mold. Zone 1 test bars are getting the first cold metal poured which explains the fine grain structure versus zones 2 and 3. Photomicrographs verify that zone 1 has much finer grain structure than the other zones, see St Louis Testing lab report 05M1167. To verify our thinking the zone 1 test bar was heat treated for 7 hours at 2050 F, the same as the coil casting. Photomicrographs indicate that the grain structure did not coarsen significantly, see St Louis Testing lab report 05M1182. Therefore we conclude the fine structure caused by cold metal entering the cavity is adversely affecting ductility at cryogenic temperatures. Photomicrographs taken at Westmoreland indicate there were no defects to cause the failure, see attached photos.

Corrective Action

Use as is.

Verification of Corrective Action

TBD

Preventive Action

Possibly relocate the cast on bars.

Estimated Completion Date

TBD

Actual Completion Date

TBD

Signed: C. Ruud

A handwritten signature in black ink, appearing to be "C. Ruud", written over a horizontal line.

CC: Jim Galaske, Barry Craig, Joe Edwards, E.J. Kubick, Jerry Markham, Roger Broman

C-5 Coil

11/18/2005

77K (-320F)

293K (RT)

Casting	Test 1							Test 2						
	Property	Required	C5-1Z	C5-2Z	C5-3Z	C5-1Z	C5-2Z	C5-3Z	Property	Required	C5-1Z	C5-2Z	C5-3Z	
Elastic Modulus	21 Msi (144.8 Gpa)	33	31.8	28	34.5	28.2	25.9	20 Msi (137.9 Gpa)	28.4	27.7	25.9			
0.2% Yield Strength	72 ksi (496.4 Mpa)	112.6	98.3	95.5	111.2	102.5	95	30 ksi	41.5	37.7	37.1			
Tensile Strength	95 ksi (655 Mpa)	182.5	166.1	163.7	177.4	172.3	163.5	78 ksi (537.8 Mpa)	92.9	84.4	83.7			
Elongation	32%	31%	52%	59%	29%	41%	64%	36%	55%	52%	67%			
Charpy V - notch Energy	35 ft. lbs. (47.4 J)	81	73	87				50 ft.-lbs (67.8 J)	130	131	156			

DISPOSITION OF CA 1454 (C5 ELONGATION)

NCSX accepts the 31% elongation (vs. 32% spec. requirement) from one of the test bars from the C5 winding form. However, we request that the details of the proposed corrective action be discussed at a Quality conference call before being implemented.

**Phil
Heitzenroeder**

Digitally signed by Phil Heitzenroeder
DN: CN = Phil Heitzenroeder, C = US,
O = PPPL, OU = Mech. Eng. Division
Reason: I am the author of this
document
Date: 2005.11.22 17:17:09 -05'00'

Tech. Rep.

Brad Nelson

Digitally signed by Brad Nelson
DN: cn=Brad Nelson, c=US,
o=ORNL, ou=FED,
email=nelsonbe@ornl.gov
Date: 2005.11.22 17:20:45 -05'00'

NCSX Core Systems Engrg. Manager



Carondelet Division

8600 Commercial Blvd. - Pevely, MO 63070 USA
Phone: 636-479-4499 - Fax: 636-479-3399

Final Inspection Report

Customer ENERGY INDUSTRIES OF OHIO

Pattern: MCWF-C5 COIL

Order PPPL-FP-LTS-2

ASTM Metal CF8MNMN MOD

Date 11/4/2005

Type Description	Cert Number	Procedure	Acceptance Criteria	Actual
Liquid Penetrant	172810-1	CQP - 300 Rev 9	SEE NOTE	Acceptable
Notes Acceptance per ASTM A903. Acceptance criteria - level 1 for high stressed areas, level 2 for all other areas.				
Mag Perm	172810-1	SOP Mag Perm 100 Rev 1	<1.02	Acceptable
Radiographic	172810-1	Technique # 12726	MSS SP 54	Acceptable
Visual	172810-1	CQP - 500 REV 4	ASTM A802 LEVEL 2	Acceptable

Liquid Penetrant

Technician: Jason Rees
ASNT Level II

Visual

Technician: Jason Rees
ASNT Level II

Respectfully Submitted,
Charles A. Ruud
Quality Assurance Manager

Superior Quality Engineered Metal Products

www.MetalTekInt.Com



Carondelet Division

8600 Commercial Blvd. - Pevely, MO 63070 USA
Phone: 636-479-4499 - Fax: 636-479-3399

Certificate of Conformance

ENERGY INDUSTRIES OF OHIO

Order Number PPPL-FP-LTS-2

Pattern MCWF-C5 COIL

ASTM CF8MNMN MOD

Date 11/4/2005

Cert Number

172810-1

A handwritten signature in black ink, appearing to read "CAR", is positioned above the signature block.

We certify that we have complied in accordance with the drawings(s) and specifications(s) listed on the above purchase order. The articles furnished were made and/or processed from parts and/or materials in accordance with all applicable drawings(s) and specifications(s) pursuant to the afore mention purchase order.

Respectfully Submitted,
Charles A. Ruud
Quality Assurance Manager

Superior Quality Engineered Metal Products

www.MetalTekInt.Com



Carondelet Division

8600 Commercial Blvd. - Pevely, MO 63070 USA
Phone: 636-479-4499 - Fax: 636-479-3399

Final Inspection Report

Customer ENERGY INDUSTRIES OF OHIO
Pattern: SE-141-073 COIL C SHIM
S/N 5

Order PPPL-FP-LTS-2

ASTM Metal CF8MNMN MOD

Date 10/28/2005

Type Description	Cert Number	Procedure	Acceptance Criteria	Actual
Liquid Penetrant	S73220-2	CQP - 300 Rev 9	ASTM A903 Level II	Acceptable
Mag Perm	S73220-2	SOP Mag Perm 100 Rev 1	<1.02	Acceptable
Radiographic	S73220-2	Technique # 12726	MSS SP 54	Acceptable
Visual	S73220-2	CQP - 500 REV 4	ASTM A802 LEVEL 2	Acceptable

Liquid Penetrant

Technician: Jim Shanahan
ASNT Level II

Visual
Technician: Jason Rees
ASNT Level II

Respectfully Submitted,
Charles A. Ruud
Quality Assurance Manager

Superior Quality Engineered Metal Products

www.MetalTekInt.Com



3

Carondelet Division

8600 Commercial Blvd. - Pevely, MO 63070 USA
Phone: 636-479-4499 - Fax: 636-479-3399

Certificate of Conformance

ENERGY INDUSTRIES OF OHIO

Order Number PPPL-FP-LTS-2

Pattern SE-141-073 COIL C SHIM

S/N 5

ASTM CF8MNMN MOD

Date 10/28/2005

Cert Number

S73220-2

C shim for C-5 coil was poured from heat number 29198. No weld repairs were necessary.

A handwritten signature in black ink, appearing to read "CAR", is located in the lower right quadrant of the page.

We certify that we have complied in accordance with the drawings(s) and specifications(s) listed on the above purchase order. The articles furnished were made and/or processed from parts and/or materials in accordance with all applicable drawings(s) and specifications(s) pursuant to the afore mention purchase order.

Respectfully Submitted,
Charles A. Ruud
Quality Assurance Manager

Superior Quality Engineered Metal Products

www.MetalTekInt.Com

EIO
Energy Industries of Ohio
SUPPLIER QUALITY RELEASE

		Date: 11-23-05
--	--	----------------

I. General Information:		
Project Name:	Modular Coil Winding Form C5	
PO No:	NCSX-SOW-141-02-01	Rev.: 9
Supplier:	MetalTek	
Procurement Agent:	EIO	
Shipment:	<input checked="" type="checkbox"/> Partial <input type="checkbox"/> Final	

II. Material Description
Casting C5 Coil

III. Release Checklist	
Plan Requirements Complete?	<input checked="" type="checkbox"/> Yes <input type="checkbox"/> No <input type="checkbox"/> N/A (If identified "No" provide explanation in comments section below)
Variations?	<input checked="" type="checkbox"/> Yes <input type="checkbox"/> No <input type="checkbox"/> N/A (If identified "No" provide explanation in comments section below)
Princeton Notified of Shipment?	<input checked="" type="checkbox"/> Yes <input type="checkbox"/> No <input type="checkbox"/> N/A (If identified "No" provide explanation in comments section below)
DCMA Notified of Shipment?	<input checked="" type="checkbox"/> Yes <input type="checkbox"/> No <input type="checkbox"/> N/A (If identified "No" provide explanation in comments section below)
<input checked="" type="checkbox"/> Conditional <input type="checkbox"/> Unconditional Explain conditional releases in comments section.	

IV. Comments
Variances – See attached package for CA's and deviations CA1454 Attached, elongation under spec

By signing below you acknowledge that the casting has met all applicable standards and contractual requirements

V. Supplier Quality Representative Sign Off		
	X	11-23-05
Supplier Quality Representative (SQR) Print/Type Name	Supplier Quality Representative (SQR) Signature	Date

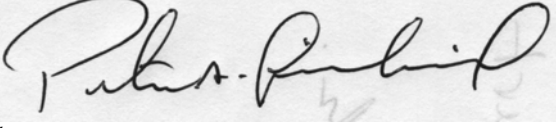
VI. Supplier Approval For Shipment		
Procurement Agent Notified of Shipment	Date: 11-23-05	
Required Vendor Data Ready for Shipment	Date: 11-23-05	
Peter A Djordjevich	 X	11-23-05

EIO
Energy Industries of Ohio
SUPPLIER QUALITY RELEASE

		Date: 11-23-05
--	--	----------------

I. General Information:		
Project Name:	Modular Coil Winding Form C5	
PO No:	NCSX-SOW-141-02-01	Rev.: 9
Supplier:	MetalTek	
Procurement Agent:	EIO	
Shipment:	<input checked="" type="checkbox"/> Partial <input type="checkbox"/> Final	
Supplier's Representative Print/Type Name	Supplier's Signature	Date

1. Enter:
Project Name
PO Number
Supplier
Procurement Agent

2. Enter a brief description of items being released, including applicable drawing number(s), dash or item number(s), drawing revision letter, specification(s), and serial number(s).

3. Self-Explanatory

4. Record any unusual circumstance, such as a conditional release.

5. The Supplier's representative shall sign and date.

7. Signature and date of the Supplier's authorized representative indicating shipping date.

8. In case of partial release, the supplier shall maintain copies of each sequential "Supplier Quality Release" and establish complete accountability of material release on final shipment.

9. Supplier shall include a copy of the completed form with each shipment.

Energy Industries of Ohio

Contract # S005242-F

Modular Coil Winding Form

C-5 Documentation Package

Part 2

Major Tool & Machine

Revised 7/18/2006

****Note – The table of contents that follows a supplemental EIO TOC as an aide to locating documents. Documents may be duplicated in this package; 1st as an attachment to a NC (not listed) & the 2nd time in the order noted in the MTM TOC.**

C-5 Documentation Package

List of Documents 7-18-06

Doc #	Description	Page #
-	MTM – Original TOC & document list	100
1	Certificate of Conformance	102
2	Completed shop travelers – 65707-4	103
3	NC 19233 – SE141-137 Bearing Plates	113
4	NC 19234 – SE141-138 Bearing Plates	115
5	NC 19511 Poloidal Break Repair	117
6	NC 19587 PT Rejections + disposition chart	121
7	NC 19607 RT Rejections	134
8	NC 19710 Final Cosmetic Repairs + LP & Mag Perm IDC	137
9	NC 19713 Final Dimensional	143
10	NC 19718 – Final Visual	160
11 -12	Material certification for studs, nuts & washers – This material to be replaced with new hardware	165
13	Material certification Loctite 411	181
14 & 19	Material certification G-11 round bar	182
15	IDC – Electrical Resistance Check	184
16	Material certification – weld wire – Metrode lot # W020132	185
17	Westmoreland test results Metrode weld lot # W020132	187
18	Material certification – GE G11-CR flat sheet insulating material	191
19	Material certification G-11 round bar (Same as document 14)	182
20	IDC – In process mag perm done during deburring op on wing area (see Doc # 2 – Shop Traveler – Sub 1 Op 40)	192
21	IDC – Clearance on VPI & counterbores + cooling holes	193
22	LP inspection certificate – Final inspection	194
23	RT map & reader sheets (also in Doc # 7)	195
24	IDC – Mag perm – Final inspection	197
25	IDC – Poloidal break (also in Doc # 9)	198
26	IDC – Final dimensional (also in Doc # 9)	199
27	LP Inspection certificate – In process (also in Doc # 8)	206
28	IDC – Mag perm – In process – weld repaired areas (also in Doc # 8)	207
29 & 31	Material certification for bearing plates - This material to be replaced with new hardware	208
30	IDC – Mag Permeability of bearing plates	212
31	Material certification for bearing plates - This material to be replaced with new hardware (same as Doc # 29)	208
32	IDC – Mag Permeability of bearing plates	213

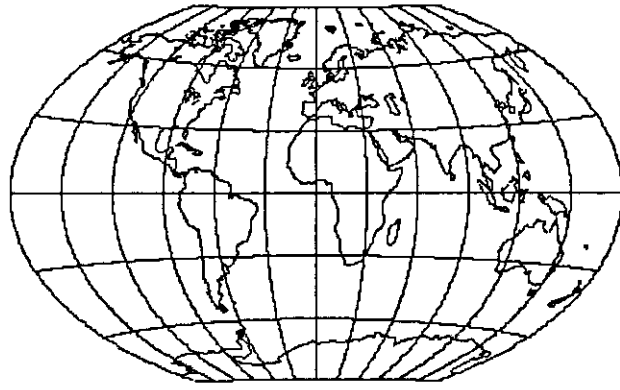

ENERGY INDUSTRIES OF OH

Purchase Order Number:

S005242-F

Part Number:

SE141-116

Part Name:

MCWF C-5

MTM Work Order Number:

65707/5.0



Major

Tool & Machine, Inc.

Customer: 8909 - ENERGY INDUSTRIES OF OHIO
Customer P.O.: S005242-F
Customer Part ID: SE141-116 - MCWF C-5

Item#	Document Description / Material Description / File Name / Heat Lot
1	CERTIFICATE OF CONFORMANCE
2	COMPLETED SHOP TRAVELERS: - 65707-5 completed shop travelers.xls
3	NC19233 - SE141-137 BEARING PLATES: - NC19233 Dispositioned.pdf
4	NC19234 - SE141-138 BEARING PLATES: - NC19234 Dispositioned.pdf
5	NC19511 - POLOIDAL BREAK REPAIR: - NC19511_C5PolBreak_041806.pdf
6	NC19587 - PT REJECTIONS: - NC19587_DPforC5.pdf
7	NC19607 - RT REJECTIONS: - NC19607_S5242_C5RT.pdf
8	NC19710 - FINAL COSMETIC REPAIRS: - NC19710 dispositioned.pdf
9	NC19713 - FINAL DIMENSIONAL : - NC19713_Signedoff_C5IDC_TGrind.pdf
10	NC19718 - FINAL VISUAL NC: - NC19718_Signedoff_C5_cleanup.pdf

DS141-036 - STUD

Item#	Sub	Op	Pc	Document Description / Material Description / File Name / Heat Lot
11	4	10	30	Material Certification: THIS HARDWARE TO BE REPLACED / DS141-036 - STUD - MC108535.TIF / 8969595

DS141-060 - NUT

Item#	Sub	Op	Pc	Document Description / Material Description / File Name / Heat Lot
12	4	10	50	Material Certification: THIS HARDWARE TO BE REPLACED / DS141-060 - NUT - MC108531.TIF / 8990135

SE141-078 - POLOIDAL BREAK SHIM ASSEMBLY

Item#	Sub	Op	Pc	Document Description / Material Description / File Name / Heat Lot
13	2	30	20	Certificate of Conformance: N/A / LOCTITE 411 - LOCKING COMPOUND - mc106229.tif / CERTIFIED

SE141-078-03 - INSULATING SLEEVE

Item#	Sub	Op	Pc	Document Description / Material Description / File Name / Heat Lot
14	3	10	10	Certificate of Conformance: / G11CR_1 - ROUND, BAR, 1.75 DIA - mc108545.tif / CERTIFIED

SE141-103

Item#	Sub	Op	Pc	Document Description / Material Description / File Name / Heat Lot
15	1	140		Inspection Data Checklist: 2 steps

SE141-103-1 - MOD COIL WINDING FORM ASSEMBLY TYPE-C

Item#	Sub	Op	Pc	Document Description / Material Description / File Name / Heat Lot
16	0	10	10	Material Certification: Trace ID: 116252 / ER316MNNF_093_GTAW - WELD WIRE,GTAW .093 DIA - mc106579.tif / W020132 / WO20132
17	0	10	10	Material Certification: Trace ID: 113686 / ER316MNNF_093_GTAW - WELD WIRE,GTAW .093 DIA - mc106164.pdf / W020132 / WO20132

SE141-103-4 - INSULATING SHEET

Item#	Sub	Op	Pc	Document Description / Material Description / File Name / Heat Lot
18	7	10	10	Certificate of Conformance: G11CR / G11CR_3 - SHEET, FLAT - mc107081.tif / CERTIFIED

SE141-103-5 - INSULATING SLEEVE

Customer: 8909 - ENERGY INDUSTRIES OF OHIO
Customer P.O.: S005242-F
Customer Part ID: SE141-116 - MCWF C-5

Item#	Sub	Op	Pc	Document Description / Material Description / File Name / Heat Lot
19	5	10	10	Certificate of Conformance: / G11CR_1 - ROUND, BAR, 1.75 DIA - Same as Item #14 / CERTIFIED

SE141-116 - MODULAR COIL WINDING FORM TYPE-C

Item#	Sub	Op	Pc	Document Description / Material Description / File Name / Heat Lot
20	1	40		Inspection Data Checklist: 1 steps
21	1	88		Inspection Data Checklist: 6 steps
22	1	100		Nondestructive Liquid Penetrant Test Certification #16421
23	1	110		Map(s): RT MAP AND READER SHEET - MC119135.PDF
24	1	120		Inspection Data Checklist: 2 steps
25	1	130		Inspection Data Checklist: 4 steps
26	1	132		Inspection Data Checklist: 83 steps
27	14	20		Nondestructive Liquid Penetrant Test Certification #16422
28	14	30		Inspection Data Checklist: 1 steps

SE141-137 - BEARING PLATE DETAIL

Item#	Sub	Op	Pc	Document Description / Material Description / File Name / Heat Lot
29	9	10	10	Material Certification: TO BE REPLACED - SEE NC19233 / 316_17 - BAR, FLAT, 1"X3", 316 SST - MC115096.TIF / M11443
30	9	40		Inspection Data Checklist: 1 steps

SE141-138 - BEARING PLATE DETAIL

Item#	Sub	Op	Pc	Document Description / Material Description / File Name / Heat Lot
31	10	10	10	Material Certification: TO BE REPLACED - SEE NC19234 / 316_17 - BAR, FLAT, 1"X3", 316 SST - Same as Item #29 / M11443
32	10	40		Inspection Data Checklist: 1 steps

CERTIFICATE OF CONFORMANCE

Page: 1
Date: 06/12/06
User ID: GRIFFIT#

TO: ENERGY INDUSTRIES OF OHIO

DATE: 04/28/2006

ATTENTION: Receiving Department

Seller certifies that:

Part Number: SE141-116

Purchase Order: S005242-F

Part Name: MCWF C-5

Workorder: 65707/5.0

Part Serial Number: C5

Quantity: 1

1. These materials and/or parts were produced in conformance with all contractually applicable Government and/or Customer specifications referred in, or furnished with, the above Purchase Order.
2. The materials and/or parts furnished under the above Purchase Order were produced:
[X] From materials furnished by Customer for the production of such parts.
[X] From materials for which the seller has available for examination chemical and/or physical test reports or other evidence of conformance to applicable specifications.
3. All processes required in the production of these part and/or materials are listed below and were performed by a facility or personnel approved or certified by the Seller and the customer when such approval or certification is required by contract.

Certifications are on file at this plant.

Other Requirements:

MANUFACTURED PER B.P. SE141-103 REV. 3 AND P.O. REQUIREMENTS.

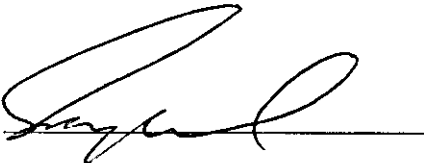
Signature: 

Title: Dusky Mae

Date: 4/28/06



Activity	Visual Mfg Ref.	Op Status	Close Date	Emp ID
Manufacturing Planning- QA planning- Production Support	65707/5.0 -Sub:0 Op#:10	Closed	4/23/2006	744-P.Schumacher
FINAL INSPECTION---PREPARE PART FOR SOURCE INSPECTION.---- Review and complete QA data package per QAP and the requirements of the product specification NCSX-CSPEC-141-03-05 September 23- 2004.-- Contact CFT to review data package prior to notifying source inspection.	65707/5.0 -Sub:0 Op#:20	Closed	4/28/2006	744-P.Schumacher
SOURCE INSPECTION --FINAL ACCEPTANCE OF PART AND DATA PACKAGE.--HAVE SOURCE INSPECTOR STAMP AND SIGN C OF C.--	65707/5.0 -Sub:0 Op#:30	Closed	4/28/2006	840-G.Masood
PACKAGE AND SHIP----BUILD A BOX/CRATE SUITABLE FOR PROTECTING THE PART FROM THE ENVIRONMENT.----WEIGH THE FINISHED PART AND METAL STAMP THE VALUE IN POUNDS ON THE CASTING IN THE AREA MARKED ON THE CUSTOMER DRAWING.---- PART MUST BE PROTECTED AND WRAPPED IN PLASTIC PRIOR TO INSERTING INTO THE CRATE. REFER TO PS583.----PART IS TO BE SHIPPED TO PPPL IN PRINCETON- NJ PER QAP SHIPPING ADDRESS.- ---CRATE MUST BE MARKED/STENCILED PER THE MTM DRAWING.--	65707/5.0 -Sub:0 Op#:40	Closed	4/28/2006	131-W.Allen
RECEIVE CUSTOMER SUPPLIED MATERIAL. ---Part Number: SE141- 116 Rev: 6--Part Description: PRODUCTION WINDING FORM TYPE-C	65707/5.0 -Sub:1 Op#:10	Closed	12/2/2005	131-W.Allen
SETUP AND MACHINE THE FLANGE FACES AND FLANGE PERIPHERY TO WITHIN .100- STOCK.	65707/5.0 -Sub:1 Op#:18	Closed	2/20/2006	005-K.Contractor
SET CASTING ON RISERS WITH DATUM -E- FLANGE DOWN. ROUGH MACHINE OUTSIDE POLOIDAL BREAK FLANGES TO WITHIN .030- OF FINISH. MACHINE POLOIDAL BREAK THROUGH THE FLANGES AND CASTING WALL TO 2.050- LEAVING THE T SECTION TO BE CUT AT A LATER TIME.	65707/5.0 -Sub:1 Op#:20	Closed	2/27/2006	345-D.Sauser
USING TABS CUT FROM CUSTOMER SUPPLIED MATERIAL- WELD TEMPORARY SHIM IN PLACE. WELD TABS TO SHIM AND TABS TO CASTING. (DO NOT WELD SHIM DIRECTLY TO CASTING)--USE MACHINED QUALIFIERS TO HELP POSITION THE SHIM.	65707/5.0 -Sub:1 Op#:25	Closed	2/27/2006	345-D.Sauser



Activity	Visual Mfg Ref.	Op Status	Close Date	Emp ID
SET UP FIXTURE PLATE MTMFX-3099 AND MACHINE LOCATING PADS AS NECESSARY.--SET UP CASTING WITH DATUM -E- AGAINST THE FIXTURE.--- MACHINE THE REMAINING PORTION OF THE POLOIDAL BREAK TO 2.050-.--- FINISH MACHINE DATUM -D- WING SURFACES AND ALL AREAS BELOW THE T SECTION.--- MACHINE T SECTION TO WITHIN .030-.--- FINISH MACHINE DATUM -D- FLANGE.--	65707/5.0 -Sub:1 Op#:30	Closed	2/27/2006	345-D.Sauser
SET UP FIXTURE PLATE MTMFX-3100 AND MACHINE LOCATING PADS AS NECESSARY.--SET UP CASTING WITH DATUM -D- AGAINST THE FIXTURE.--- FINISH MACHINE DATUM -E- WING SURFACES AND ALL AREAS BELOW THE T SECTION.--- MACHINE T SECTION TO WITHIN .030-.--- FINISH MACHINE DATUM -E- FLANGE.--	65707/5.0 -Sub:1 Op#:35	Closed	3/8/2006	713-M.Smith
DEBURR COMPLETE BOTH FLANGES- INCLUDING ALL HOLES AND COUNTERBORES. REMOVE ANY ROUGHNESS ON THE LARGE WING AREAS USING SCOTCH BRITE (MACHINE SCALLOPS ARE ACCEPTABLE).	65707/5.0 -Sub:1 Op#:40	Closed	3/8/2006	576-J.Geisinger
CD-1 (SETUP 1)--SET UP MTMFX-3099 ON ANGLE PLATE.--LOAD PART WITH DATUM -D- FLANGE UP.--VERIFY FLATNESS OF DATUM -D- FACE AND RECORD RESULTS IN IDC (SEE LINKED DATUM -D- MAP)--RECORD TOOLING BALL LOCATIONS IN IDC.--COMPLETE ALL PROGRAMS FOR SETUP 1.	65707/5.0 -Sub:1 Op#:50	Closed	3/17/2006	445-J.Purkhiser
CD-2 (SETUP 2)--SET CASTING ON RISERS WITH DATUM -D- FLANGE UP. --RECORD TOOLING BALL LOCATIONS IN IDC. COMPLETE ALL PROGRAMS FOR SETUP 2.	65707/5.0 -Sub:1 Op#:55	Closed	3/22/2006	445-J.Purkhiser
CE-2 (SETUP 4)--SET CASTING ON RISERS WITH DATUM -E- FLANGE UP. --RECORD TOOLING BALL LOCATIONS IN IDC. --COMPLETE ALL PROGRAMS FOR SETUP 4.	65707/5.0 -Sub:1 Op#:60	Closed	3/29/2006	315-C.Land
CE-1 (SETUP 3)--SET UP MTMFX-3100 ON ANGLE PLATE.--LOAD PART WITH DATUM -E- FLANGE UP.--VERIFY FLATNESS OF DATUM -E- FACE AND RECORD RESULTS ON IDC (SEE LINKED DATUM -E- MAP)--RECORD TOOLING BALL LOCATIONS IN IDC.--COMPLETE ALL PROGRAMS FOR SETUP 3.--	65707/5.0 -Sub:1 Op#:70	Closed	4/3/2006	315-C.Land



Activity	Visual Mfg Ref.	Op Status	Close Date	Emp ID
SET PART BACK ON CD-1 (SETUP 1 FIXTURE)--FINISH MACHINE THE SOUTH T SECTION OF THE POLOIDAL BREAK TO FINISH. MACHINE THE OPPOSITE T SECTION TO MATCH THE OUTER POLOIDAL BREAK SURFACE THAT WAS MACHINED OFF OF LOCATION. T SECTION OF THE BREAK SHOULD FINISH AT 2.350. DO NOT MACHINE THE BREAK ANY LARGER THAN 2.370-.	65707/5.0 -Sub:1 Op#:75	Closed	4/4/2006	315-C.Land
POLOIDAL BREAK OPERATION (SETUP 5)--- INSTALL MTMFX-3099 ON RISERS. --- TACK WELD FIXTURE TO RISER BLOCKS TO PREVENT MOVEMENT.--- LOAD PART ON FIXTURE WITH DATUM -D- FLANGE UP. --- TACK WELD DATUM -E- FLANGE TO THE FIXTURE ON EITHER SIDE OF THE POLOIDAL BREAK.--- TACK WELD BRACING TO PREVENT MOVEMENT OF THE POLOIDAL BREAK WHEN THE TEMPORARY SHIM IS REMOVED. TABS MADE FROM THE CASTING MATERIAL ARE TO BE WELDED TO THE BRACING AND THEN THE TABS WELDED TO THE CASTING.--- RECORD TOOLING BALL LOCATIONS IN IDC. --- REMOVE SHIM AND FINISH MACHINE POLOIDAL BREAK.--- INSTALL DRILL FIXTURE AND COMPLETE GUN DRILLING OPERATION.--- COMPLETE ALL REMAINING PROGRAMS FOR SETUP 5.--- REMOVE THE DRILL FIXTURE AND INSTALL THE TWO TAPERED PINS. PLACE ALUMINUM BLOCKS IN THE POLOIDAL BREAK AND CLAMP OVER THE BLOCKS TO MINIMIZE ANY MOVEMENT DURING HANDLING. --- VERIFY THAT QUALIFIERS HAVE BEEN CUT ON THE OUTER DIAMETERS OF THE -D- AND -E- FLANGES ACROSS THE POLOIDAL BREAK. THIS WILL BE USED FOR ALIGNMENT DURING THE ASSEMBLY OPERATION.--- CUT THE TACKS AND BRACING LOOSE AND REMOVE THE PART FROM THE FIX	65707/5.0 -Sub:1 Op#:80	Closed	4/19/2006	315-C.Land



Activity	Visual Mfg Ref.	Op Status	Close Date	Emp ID
PROTECT PART FROM METAL CONTAMINATION DUE TO CONTACT WITH IRON- SPECIFICALLY WHEN RIGGING PART FOR MOVEMENT.-- ALL GRINDING WHEELS AND DISKS MUST BE VIRGIN MATERIAL NOT PREVIOUSLY USED ON ANY OTHER MATERIAL TO AVOID MATERIAL CONTAMINATION.----- FINISH HAND TAPPING OF 3/8-16 HOLES USING TAP GUIDE (IF REQUIRED)--- START BLENDING T-SECTION--- HAND GRIND 1/16 CHAMFER ON ALL SPLIT LINE EDGES OF POLOIDAL BREAK AND ON ALL THRU HOLES AT POLOIDAL BREAK.--- HAND GRIND VPI GROOVE WHERE REQUIRED.--- DEBURR WING AREAS TO REMOVE ANY SHARPNESS FROM MACHINING (SCALLOPS DO NOT NEED TO BE REMOVED).--- CHECK ALL ACCESSIBLE T CLEARANCES USING MTMFX-3473 CHECKING FIXTURE--- HAND GRIND 1/16 TO 3/32 CHAMFER ON OUTER EDGE OF T IN ALL ACCESSIBLE AREAS.--- FINISH ALL OTHER REQUIRED DEBURRING ON DATUM -D- SIDE PRIOR TO MOVING PART TO PLANT 2 FOR FLIPPING.	65707/5.0 -Sub:1 Op#:85	Closed	4/11/2006	219-T.Laird
PROTECT PART FROM METAL CONTAMINATION DUE TO CONTACT WITH IRON- SPECIFICALLY WHEN RIGGING PART FOR MOVEMENT.-- ALL GRINDING WHEELS AND DISKS MUST BE VIRGIN MATERIAL NOT PREVIOUSLY USED ON ANY OTHER MATERIAL TO AVOID MATERIAL CONTAMINATION.----- FLIP PART AND SET UP ON DATUM -D-.--- START BLENDING T SECTION--- DEBURR WING AREAS TO REMOVE ANY SHARPNESS FROM MACHINING (SCALLOPS DO NOT NEED TO BE REMOVED).--- CHECK ALL ACCESSIBLE T CLEARANCES USING MTMFX-3473 CHECKING FIXTURE--- HAND GRIND 1/16 TO 3/32 CHAMFER ON OUTER EDGE OF T IN ALL ACCESSIBLE AREAS.--- USING 1/4- NUMBERS- STAMP NUMBERS ON FACE OF T PER DRAWING. USE DRAWING SE141-116-2MTM REV 6A FOR STAMPING NUMBERS.----	65707/5.0 -Sub:1 Op#:88	Closed	4/21/2006	744-P.Schumacher
HAND GRIND VPI GROOVE AND AREAS OF CAST STOCK THAT WERE NOT REMOVED BY MACHINING. SEE ROB BACKEK FOR DETAILS.	65707/5.0 -Sub:1 Op#:89	Closed	4/12/2006	219-T.Laird



Activity	Visual Mfg Ref.	Op Status	Close Date	Emp ID
PERFORM COSMETIC DEBURR AND FINAL CLEAN.--PROTECT PART FROM METAL CONTAMINATION DUE TO CONTACT WITH IRON-SPECIFICALLY WHEN RIGGING PART FOR MOVEMENT.--MOVE PART INTO WASH BOOTH. --THOROUGHLY CLEAN AND DRY ALL SURFACES AND HOLES PER SECTION 9 OF PS583. --PARTS TO BE WASHED USING HEATED- DE-MINERALIZED WATER- AND IF NECESSARY- A MILD NON-CHLORINATED CLEANING SOLUTION (E.G. SIMPLE GREEN®- OR AUTHORIZED EQUIVALENT)- USING MTM'S HIGH PRESSURE WASHER. THE SPRAY PRESSURE AT THE NOZZLE WILL BE APPROXIMATELY 1-000 TO 1-500 PSI AND THE CLEANING SOLUTION TEMPERATURE WILL BE APPROXIMATELY 150°F.--HAVE INSPECTION VERIFY THE CLEANLINESS OF THE CASTING PRIOR TO REMOVING FROM THE WASH BOOTH.--	65707/5.0 -Sub:1 Op#:90	Closed	4/12/2006	219-T.Laird
PT 100% OF FINISHED MACHINED SURFACES ONLY. SEE PS582 FOR PROCESSING INSTRUCTIONS. ----MTM CERTIFICATION TO INCLUDE THE INFORMATION PER SUPPLEMENTARY REQUIREMENTS S1 OF ASTM A903/A903M----MTM NDT Cert: LPI CERTIFICATION-- Specification: ASTM A903/A903M--Method: E165--Acceptance: ASTM A903/A903M LEVEL 1	65707/5.0 -Sub:1 Op#:100	Closed	4/24/2006	581-D.Edwards
GOVERNMENT SOURCE INSPECTOR TO WITNESS PT RESULTS.	65707/5.0 -Sub:1 Op#:101	Closed	4/25/2006	840-G.Masood



Activity	Visual Mfg Ref.	Op Status	Close Date	Emp ID
THE -T- AREAS DEFINED AS -HIGH STRESS- ARE TO BE RT 100%. SEE PS581 FOR PROCESS INSTRUCTIONS.----HAND SKETCH A LAYOUT OF ALL FILM LOCATIONS ON ATTACHED RT MAP. ----ALL FILM IS TO BE DOUBLED UP IN ORDER TO SUPPLY THE CUSTOMER WITH A COMPLETE SET OF FILM.----SPECIFICATIONS: ASTM A703/A703M SUPPLEMENTARY REQUIREMENT S5---- PROCEDURE/METHOD: ASTM E94 AND ASTM E142 (USE OF A WIRE PENETRATOR MAY BE NECESSARY INSTEAD OF THE HOLE TYPE TO ENSURE OBJECTIVE 2% OF THICKNESS RESOLUTION/SENSITIVITY)---ACCEPTANCE CRITERIA: NO DEFECT LARGER THAN .080- MAJOR DIMENSION IS ALLOWED.----SCAN RT CERTIFICATION- AND HAND SKETCHED MAP AND LINK IN QAP TO THIS OPERATION.----Certification: RADIOGRAPHIC INSPECTION-- Map(s): RT MAP Rev: --Part Number: SE141-116 Rev: 8--Part Description: WINDING FORM TYPE-C--Material Type: 316 SST--Material Thickness: VARIES	65707/5.0 -Sub:1 Op#:110	Closed	4/13/2006	010-R.Contractor
GOVERNMENT SOURCE INSPECTOR TO WITNESS RT RESULTS.	65707/5.0 -Sub:1 Op#:111	Closed	4/25/2006	840-G.Masood
PERFORM A MAG PERMEABILITY CHECK OF THE MACHINED SURFACES USING A SEVERN PERMEABILITY INDICATOR GAGE. PERMEABILITY SHOULD BE NO GREATER THAN 1.02μ.----CHECK THE PERMEABILITY IN 3 PLACES ON EACH SIDE OF THE T SECTION AT LOCATIONS ADJACENT TO EVERY 5TH HOLE STARTING WITH HOLE 5 AND ENDING WITH HOLE 95. INSPECT ONE POINT ON THE T SECTION- ANOTHER BELOW THE VPI GROOVE AND THE LAST POINT ON THE FLANGE. REPEAT THIS PROCESS ON BOTH SIDES OF THE PART. THERE WILL BE A TOTAL OF 57 POINTS INSPECTED PER SIDE. ----COMPLETE THE IDC INDICATING THE PERMEABILITY RANGE.--Part Number: SE141-116 Rev: 8--Part Description: PRODUCTION WINDING FORM TYPE-C	65707/5.0 -Sub:1 Op#:120	Closed	4/25/2006	840-G.Masood
SOURCE FOR MAG PERMEABILITY	65707/5.0 -Sub:1 Op#:121	Closed	4/25/2006	840-G.Masood



Activity	Visual Mfg Ref.	Op Status	Close Date	Emp ID
SET PART ON RISERS WITH DATUM -D- FLANGE DOWN. PLACE A RISER ON EITHER SIDE OF THE POLOIDAL BREAK TO ENABLE CLAMPING TO ENSURE THAT THE DATUMS ARE COPLANER. LAY A STRAIGHT EDGE ACROSS THE DATUM -D- FLANGE TO VERIFY ALIGNMENT. ENSURE RADIAL ALIGNMENT BY LAYING A STRAIGHT EDGE ACROSS THE QUALIFIERS CUT ON THE OD OF EACH FLANGE. USE CLAMPS AS NECESSARY TO FORCE THE CASTING INTO POSITION.--ONCE THE ALIGNMENT IS SET- INSTALL THE POLOIDAL BREAK SHIM ASSEMBLY AND ACCOMPANYING HARDWARE AND INSULATION PER THE ASSEMBLY DRAWING.--VERIFY CLEARANCE OF Ø.001 - - Ø.002 BETWEEN BUSHING AND BOLT PER DRAWING NOTE 13. RECORD RESULTS IN IDC.--APPLY THRED-GARD ANTI-SEIZE TO HARDWARE PER DRAWING NOTE 10.--TORQUE THE ASSEMBLY TO 1500 FT-LBS.--VERIFY GAP AT POLOIDAL BREAK PER IDC.--Part Number: SE141-116 Rev: 8--Part Description: WINDING FORM TYPE-C	65707/5.0 -Sub:1 Op#:130	Closed	4/26/2006	524-G.Davis
CMM INSPECT AND COMPLETE IDC. OUTPUT INSPECTION RESULTS FOR VERIFICATION USING VERISURF SOFTWARE.----Part Number: SE141-116 Rev: 8--Part Description: WINDING FORM TYPE-C	65707/5.0 -Sub:1 Op#:132	Closed	4/26/2006	339-E.Root
SOURCE INSPECTION - FINAL ACCEPTANCE OF PART AND DATA PACKAGE. HAVE SOURCE INSPECTOR STAMP AND SIGN C OF C.	65707/5.0 -Sub:1 Op#:133	Closed	5/1/2006	578-S.Martinez



Activity	Visual Mfg Ref.	Op Status	Close Date	Emp ID
THE RESISTANCE OF THE MID-PLANE ELECTRICAL INSULATION SHALL BE GREATER THAN 500 KOHMS WHEN TESTED AT 100 VDC.--- -TEST 1:--THE INSULATION RESISTANCE BETWEEN THE MID-PLANE POLOIDAL BREAK SHIM AND WINDING FORM SHALL BE MEASURED. DURING THIS TEST- THE BOLTS SHOULD BE IN THEIR NORMAL STATE (I.E.- ELECTRICALLY -FLOATING-). THE MID-PLANE SHIM SHALL BE CONNECTED TO ONE SIDE OF THE MEGGER- AND THE CASTING SHALL BE CONNECTED TO THE OTHER. RECORD RESULTS IN IDC.----TEST 2:--ALL OF THE BOLTS SHALL BE ELECTRICALLY CONNECTED (JUMPERED) TOGETHER IN ONE GROUP. THE MID-PLANE CASTING (SHIM) AND THE WINDING FORM SHALL BE ELECTRICALLY CONNECTED TOGETHER IN A SECOND GROUP. THE INSULATION RESISTANCE BETWEEN THE JUMPERED BOLTS (GROUP 1) AND THE JUMPERED WINDING FORM AND MID-PLANE (GROUP 2) SHALL BE MEASURED FOR COMPLIANCE. RECORD RESULTS IN IDC.----Part Number: SE141-103--Part Description: MCWF ASSEMBLY TYPE-C	65707/5.0 -Sub:1 Op#:140	Closed	4/25/2006	840-G.Masood
SOURCE FOR ELECTRICAL TEST	65707/5.0 -Sub:1 Op#:150	Closed	4/25/2006	840-G.Masood
RECEIVE CUSTOMER SUPPLIED CASTING	65707/5.0 -Sub:2 Op#:10	Closed	12/9/2005	437-J.Hiatt
MACHINE THE SHIM COMPLETE PER THE DRAWING AND CNC PROGRAMS.	65707/5.0 -Sub:2 Op#:20	Closed	3/1/2006	234-E.Booher
ASSEMBLE (5) OF THE INSULATING SLEEVES INTO THE SHIM AND BOND USING LOCTITE 411. DO NOT INSTALL THE BUSHINGS IN THE OUTSIDE HOLES. THEY WILL BE INSTALLED LATER.	65707/5.0 -Sub:2 Op#:30	Closed	4/14/2006	825-B.Jarrett
SAW OFF 16- AND MOVE TO NEXT WORK CENTER.	65707/5.0 -Sub:3 Op#:10	Closed	6/4/2005	227-D.Bockover
MACHINE PER THE DRAWING FOR A SLIP FIT WITH MATING DETAIL. OBTAIN FINISHED MACHINED CASTING SHIM BEFORE FINAL SIZING THE O.D. OF THE SLEEVE.	65707/5.0 -Sub:3 Op#:20	Closed	4/11/2006	236-M.Jennings
RECEIVE MATERIAL--NOTIFY CFT AND FORWARD MATERIAL STORES.	65707/5.0 -Sub:4 Op#:10	Closed	6/1/2005	131-W.Allen
SAW OFF 30- LENGTH AND MOVE TO NEXT WORK CENTER.	65707/5.0 -Sub:5 Op#:10	Closed	6/4/2005	227-D.Bockover
MACHINE PER THE DRAWING FOR A SLIP FIT WITH MATING DETAIL. CHECK FINISHED MACHINED CASTING BEFORE FINAL SIZING THE O.D. OF THE SLEEVE.	65707/5.0 -Sub:5 Op#:20	Closed	5/1/2006	176-J.Denney



Activity	Visual Mfg Ref.	Op Status	Close Date	Emp ID
SAW 13- LENGTH AND MOVE TO NEXT WORK CENTER.	65707/5.0 -Sub:6 Op#:10	Closed	6/2/2005	227-D.Bockover
RECEIVE MATERIAL	65707/5.0 -Sub:7 Op#:10	Closed	4/5/2005	131-W.Allen
MACHINE THE PROFILE LEAVING STOCK PER PROGRAM.----ALSO MACHINE OUT FLAT STOCK PIECES FOR SHIMS BEHIND THE OUTSIDE OF POLOIDAL BREAK FLANGE PER CNC PROGRAM.	65707/5.0 -Sub:7 Op#:20	Closed	9/14/2005	129-E.Taina
SAW TO A LENGTH OF 6.75-.	65707/5.0 -Sub:9 Op#:10	Closed	1/10/2006	227-D.Bockover
MACHINE BEARING PLATES COMPLETE FROM MATERIAL SUPPLIED BY MAJOR TOOL.--VENDOR TO SUPPLY DIMENSIONAL INSPECTION REPORT.--MTM TO DO ALL NDT TESTING PER NOTE 5.--Part Number: SE141-137 Rev: 1--Part Description: BEARING PLATE--Dimensional Report: VENDOR SUPPLIED--Dimensional Report: VENDOR SUPPLIED	65707/5.0 -Sub:9 Op#:30	Closed	2/8/2006	subcontact
PERFORM A MAGNETIC PERMEABILITY CHECK USING A SEVERN PERMEABILITY INDICATOR GAGE. PERMEABILITY SHOULD BE NO GREATER THAN 1.03μ.--Part Number: SE141-137 Rev: 1--Part Description: BEARING PLATE DETAIL	65707/5.0 -Sub:9 Op#:40	Closed	2/8/2006	503-B.Houk
SAW TO A LENGTH OF 10.5-.	65707/5.0 -Sub:10 Op#:10	Closed	1/10/2006	227-D.Bockover
MACHINE BEARING PLATES COMPLETE FROM MATERIAL SUPPLIED BY MAJOR TOOL.--VENDOR TO SUPPLY DIMENSIONAL INSPECTION REPORT.--MTM TO DO ALL NDT TESTING PER NOTE 5.----Part Number: SE141-138 Rev: 1--Part Description: BEARING PLATE--Dimensional Report: VENDOR SUPPLIED--Dimensional Report: VENDOR SUPPLIED	65707/5.0 -Sub:10 Op#:30	Closed	2/8/2006	subcontact
PERFORM A MAGNETIC PERMEABILITY CHECK USING A SEVERN PERMEABILITY INDICATOR GAGE. PERMEABILITY SHOULD BE NO GREATER THAN 1.03μ.--Part Number: SE141-138 Rev: 1--Part Description: BEARING PLATE DETAIL	65707/5.0 -Sub:10 Op#:40	Closed	2/8/2006	503-B.Houk
WELD MARKED UP AREAS AND BLEND REPAIRS SMOOTHE. MAKE SURE THAT AREAS REMAIN IDENTIFIED FOR NDT.--BLEND OUT ALL OTHER MARKED AREAS.--	65707/5.0 -Sub:14 Op#:10	Closed	4/21/2006	233-G.Stupples
PENETRANT INSPECT WELD REPAIR.--Specification: ASTM A903/A903M LEVEL 1--MTM NDT Cert: REPAIR OF DEFECTS	65707/5.0 -Sub:14 Op#:20	Closed	4/24/2006	581-D.Edwards



Activity	Visual Mfg Ref.	Op Status	Close Date	Emp ID
PERFORM A RELATIVE MAGNETIC PERMEABILITY CHECK OF THE REPAIRED AREAS. VERIFY PERMEABILITY IS LESS THAN 1.02. PERMEABILITY TO BE CHECKED AT A MINIMUM OF 1 POINT EVERY 2 SQR. INCHES IN THE REPAIRED REGION.--	65707/5.0 -Sub:14 Op#:30	Closed	4/26/2006	503-B.Houk
MAP OUT THE AREAS THAT REQUIRE GRINDING AS DEFINED ON THE CUSTOMER SUPPLIED DOCUMENT. INSPECT THE WINDING AND RECORD THE RESULTS ON THE CUSTOMER MAP THAT CORRESPOND TO THE IDENTIFIED AREAS. THIS DATA WILL BE USED TO VERIFY THAT SUFFICIENT STOCK HAS BEEN REMOVED AFTER GRINDING.	65707/5.0 -Sub:15 Op#:10	Closed	4/26/2006	503-B.Houk
GRIND THE AREAS OF HEAVY STOCK THAT ARE MAPPED ON THE T SECTION. VERIFY THAT THE MINIMUM AMOUNT OF STOCK HAS BEEN REMOVED BY COMPARING THE INSPECTION RESULTS AFTER GRIND TO THE ORIGINAL RESULTS.	65707/5.0 -Sub:15 Op#:20	Closed	4/26/2006	524-G.Davis
RECORD THE FINAL INSPECTION RESULTLS ON THE CUSTOMER SUPPLIED MAP. VERIFY THAT THE MINIMUM AMOUNT OF MATERIAL HAS BEEN REMOVED AND THAT THE SURFACE CONDITION OF THE T IS ACCEPTABLE AFTER GRIND.	65707/5.0 -Sub:15 Op#:30	Closed	4/26/2006	524-G.Davis

Major Tool & Machine, Inc.
1458 East 19th Street
Indianapolis, IN 46218-4289

MTM N/C: 19233

Page: 1
Date: 02/17/06
User ID: GRIFFITH

Customer: ENERGY INDUSTRIES OF OHIO
Contact: NANCY HORTON
E-Mail: NKHFlowen@aol.com

Telephone: 216-496-2314
Fax: 216-328-2001

Part: SE141-137 /
Drawing ID: SE141-137 Revision: 1

Customer P.O.: S005242-F/Ln:4
Serial No./Qty: 12 PCS.

Reported By: MIKE GRIFFITH
E-Mail: mGriffith@MajorTool.com

Telephone: 317-636-6433
Fax: 317-634-9420

Problem: PER RFD 14-011 MAGNETIC PERMEABILITY TO BE NO GREATER THAN 1.03.
BEARING PLATES FOR C4, C5 AND C6 CHECK BETWEEN 1.03 AND 1.05.

Proposed Disposition:
PROPOSE TO USE AS IS.

Number of additional pages: _____

Customer Disposition: Use As Is Rework Repair Scrap Replace

The material specified for the bearing plates will be changed to Stellanloy. The bearing plates for all MCWFs except C1, C2, C3 (already been accepted by NCSX) shall be made of Stellanloy.

Major Tool Implemented By: Mike Griffith Title: CST ENGINEER Date: 3/23/06

PER ATTACHED EMAIL, PARTS WILL BE SHIPPED WITH HIGH PERMEABILITY BEARING PLATES UNTIL NEW PLATES ARE AVAILABLE.

Approved by:

Phil
Heitzenroeder

Digitally signed by Phil Heitzenroeder
DN: CN = Phil Heitzenroeder, C = US, O = PPPPL, OU = Mech. Eng. Division
Reason: I agree to the terms defined by the placement of my signature on this document
Date: 2006.03.20 17:27:05 -05'00'

Brad
Nelson

Digitally signed by Brad Nelson
DN: cn=Brad Nelson, c=US, o=ORNL, ou=FED, email=nelsonbe@ornl.gov
Date: 2006.03.21 00:59:03 -05'00'

Tech. Rep.,

RLM

\\ntm\apps\M\mnc14.qrp

Major Tool and Machine, Inc. 1458 East 19th Street, Indianapolis, IN 46218-4289 Tel: 317-636-6433 Fax: 317-634-9420

Griffith, Mike

From: Larry L. Sutton [lsutton@pppl.gov]
Sent: Wednesday, March 22, 2006 5:58 PM
To: NKHFlowen@aol.com
Cc: Phil Heitzenroeder; royjratc-aol-com-offsite; Frank A. Malinowski
Subject: Subcontract S005242-F - Use of Stellanloy Bearing Plates

Nancy:

Phil directed I dispatch to you the following information.

"This is to confirm the telephone conversation between Nancy Horton, Phil Heitzenroeder, and Larry Sutton on 3/17 and a phone conversation with Phil on 3/22. NCSX is changing the material for the bearing plates to Stellanloy for modular coil winding forms C4-C5, A1-A6, and B1-B6. We realize that implementing this change will not be possible for the next 2-3 winding forms. For those winding forms where the Stellanloy bearing plates are not available at shipment, we would ask that they be shipped with the 316 stainless steel bearing plates currently on hand which have high magnetic permeability. NCR's should be issued to document those shipped with the high permeability bearing plates. These will be replaced with Stellanloy bearing plates when the studs and nuts are replaced with the A286 versions at PPPL. MTM kindly agreed in a telephone conversation this morning which involved Roy to put paint dots on the hardware and bearing plates which will need to be replaced at PPPL."

Regards,

Larry

Major Tool & Machine, Inc.
1458 East 19th Street
Indianapolis, IN 46218-4289

MTM N/C: 19234

Page: 1
Date: 02/17/06
User ID: GRIFFITH

Customer: ENERGY INDUSTRIES OF OHIO
Contact: NANCY HORTON
E-Mail: NKHFlowen@aol.com

Telephone: 216-496-2314
Fax: 216-328-2001

Part: SE141-138 /
Drawing ID: SE141-138

Revision: 1

Customer P.O.: S005242-F/Ln:4
Serial No./Qty: 6

Reported By: MIKE GRIFFITH
E-Mail: mGriffith@MajorTool.com

Telephone: 317-636-6433
Fax: 317-634-9420

Problem: PER RFD 14-011 MAGNETIC PERMEABILITY TO BE NO GREATER THAN 1.03.
BEARING PLATES FOR C4, C5 AND C6 CHECK BETWEEN 1.03 AND 1.05.

Proposed Disposition:
PROPOSE TO USE AS IS.

Number of additional pages: _____

Customer Disposition: Use As Is Rework Repair Scrap Replace

Refer also to N/C19233. The material specified for the bearing plates will be changed to Stلالloy. The bearing plates for all MCWFs except C1, C2, C3 (already been accepted by NCSX) shall be made of Stلالloy.

Major Tool Implemented By: Mike Griffith Title: CFT ENGINEER Date: 3/23/06
Approved by: PER ATTACHED EMAIL, PARTS WILL BE SHIPPED WITH HIGH PERMEABILITY BEARING PLATES UNTIL NEW PLATES ARE AVAILABLE.

Phil
Heitzenroe
der

Digitally signed by Phil
Heitzenroeder
DN: CN = Phil Heitzenroeder, C
= US, O = PPPL, OU = Mech.
Eng. Division
Reason: I agree to 'specified'
portions of this document
Date: 2006.03.20 17:37:02 -
05'00'

Brad
Nelson

Digitally signed by Brad
Nelson
DN: cn=Brad Nelson,
c=US, o=ORNL, ou=FED,
email=nelsonbe@ornl.gov
Date: 2006.03.21 00:59:46
-05'00'

Tech. Rep.

RLM

a:\mtmapps\Minone14.qrp

Major Tool and Machine, Inc. 1458 East 19th Street, Indianapolis, IN 46218-4289 Tel: 317-636-6433 Fax: 317-634-9420

Griffith, Mike

From: Larry L. Sutton [lsutton@pppl.gov]
Sent: Wednesday, March 22, 2006 5:58 PM
To: NKHFlowen@aol.com
Cc: Phil Heitzenroeder; royjratc-aol-com-offsite; Frank A. Malinowski
Subject: Subcontract S005242-F - Use of Stellalloy Bearing Plates

Nancy:

Phil directed I dispatch to you the following information.

"This is to confirm the telephone conversation between Nancy Horton, Phil Heitzenroeder, and Larry Sutton on 3/17 and a phone conversation with Phil on 3/22. NCSX is changing the material for the bearing plates to Stellalloy for modular coil winding forms C4-C5, A1-A6, and B1-B6. We realize that implementing this change will not be possible for the next 2-3 winding forms. For those winding forms where the Stellalloy bearing plates are not available at shipment, we would ask that they be shipped with the 316 stainless steel bearing plates currently on hand which have high magnetic permeability. NCR's should be issued to document those shipped with the high permeability bearing plates. These will be replaced with Stellalloy bearing plates when the studs and nuts are replaced with the A286 versions at PPPL. MTM kindly agreed in a telephone conversation this morning which involved Roy to put paint dots on the hardware and bearing plates which will need to be replaced at PPPL."

Regards,

Larry

Customer: ENERGY INDUSTRIES OF OHIO

Contact: NANCY HORTON
E-Mail: NKHFlowen@aol.com

Telephone: 216-496-2314
Fax: 216-328-2001

Part: SE141-116 / MODULAR COIL WINDING FORM TYPE
Drawing ID: SE141-116 Revision: 8

Customer P.O.: S005242-F/Ln:5
Serial No./Qty: C5

Reported By: MIKE GRIFFITH
E-Mail: mGriffith@MajorTool.com

Telephone: 317-636-6433
Fax: 317-634-9420

Problem: Sheet 6, zone F2; 1.125 +/- .010 checks 1.025".

Outer portion of poloidal break between the poloidal break flanges was machined off of centerline approximately .100". The inner portion of the break (T section) was machined on location which caused a mismatch in the break surface.

Proposed Disposition:

PROPOSED REPAIR

Machine the stock heavy side of the break to the correct location per the drawing. This will blend into the area of the T that is currently undercut. Machine the T section to match the flange surface that was cut off of location (approximately .100"). The slot width will finish at approximately 2.350" rather than 2.250". In order to accommodate the oversized slot, the shim thickness will need to be machined to 2.225 rather than 2.125". The additional .100" of stock will be added to only one surface on the shim and profile machined accordingly. (see attachment)

Number of additional pages: 1 attachment

Customer Disposition: Use As Is Rework Repair Scrap Replace

MTM inadvertently undercut the surface of the T by 0.080 inches in C5 as shown in the figure in the attached Rapid Response documentation. A conference call attended by Ray Sheppard of EIO, Mike Griffith of MTM, David Williamson of ORNL, and Phil Heitzenroeder of PPPL was held at approximately 5:30 p.m. on 3/29/06 to discuss this and MTM's proposed resolution. MTM will machine the poloidal break slot width to 2.350 inches rather than 2.250 inches. The cast shim plate will be machined to the 2.350 inch dimension to compensate. Mike Griffith noted that even with this increased slot width the break flange thickness will still be within tolerance.

Approved by:

**Phil
Heitzenroeder**

Digitally signed by Phil Heitzenroeder
DN: CN = Phil Heitzenroeder, C = US, O = PPPL, OU = Mech. Eng. Division
Reason: I agree to 'specified' portions of this document
Date: 2006.04.19 09:36:25 -04'00'

**Brad
Nelson**

Digitally signed by Brad Nelson
DN: cn=Brad Nelson, c=US, o=ORNL, ou=FED, email=nelsonbe@ornl.gov
Date: 2006.04.19 22:15:33 -04'00'

Tech. Rep.

RLM

**Mike
Griffith**

Digitally signed by Mike Griffith
DN: cn=Mike Griffith, c=US, o=Major Tool and Machine, ou=CFT - White, email=mgriffith@majortool.com
Reason: I agree to the terms defined by the placement of my signature on this document
Date: 2006.04.28 10:08:48 -04'00'

Major Tool Implemented By: _____

Title: _____

Date: _____

65707/5 (C5)
SE141-116



Rapid response NCR disposition for MCWF C5

MTM inadvertently undercut the surface of the T by 0.080 inches as shown in the following figure. A conference call attended by Ray Sheppard of EIO, Mike Griffith of MTM, David Williamson of ORNL, and Phil Heitzenroeder of PPPL was held at approximately 5:30 p.m. on 3/29/06 to discuss this and MTM's proposed resolution. The right hand figure shows their proposed repair, which is to machine the slot width to 2.350 inches rather than 2.250 inches. The cast shim plate will be machined to the 2.350 inch dimension to compensate. Mike Griffith noted that even with this increased slot width the break flange thicknesses will still be within tolerance. David and Phil agreed with this proposed repair. EIO will write this up as a formal NCR for formal disposition tomorrow.

65707/5 (C5)
SE141-116



Major
Tool & Machine, Inc.

Flange area of poloidal break
finished machined .100" off
location to this side.

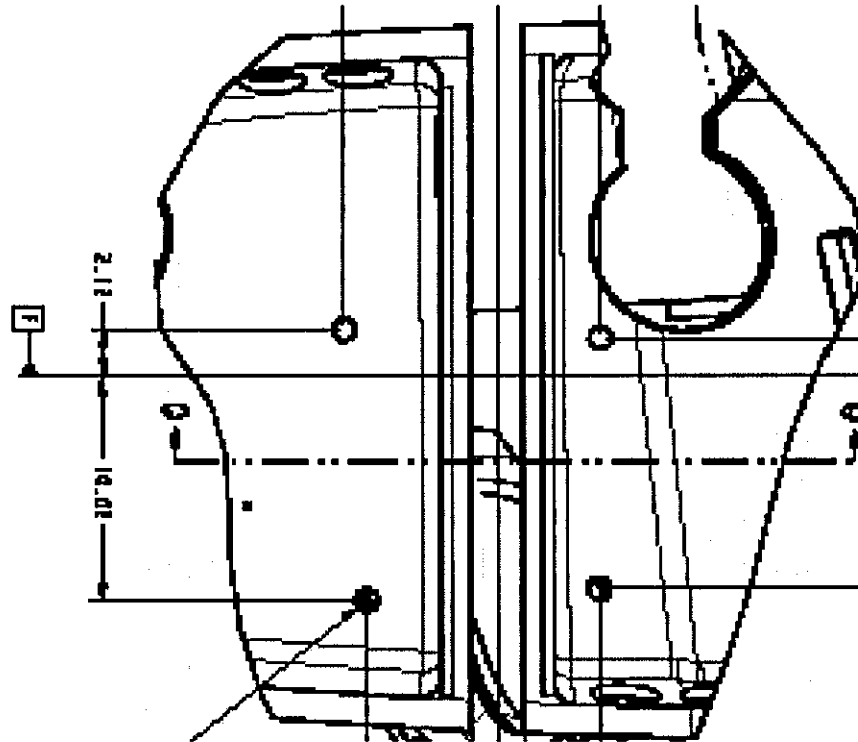
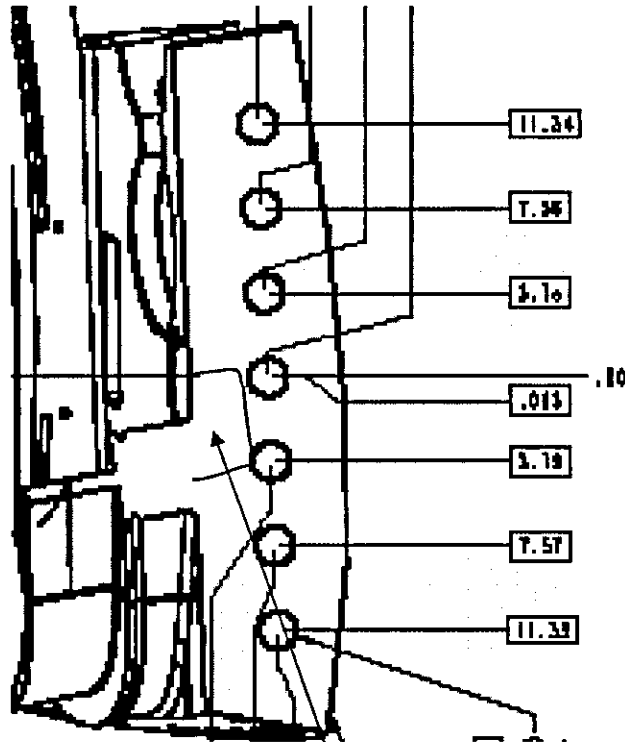

The area of the T section inward including the area highlight in red has been undercut into this surface approximately .08". This area has been cut on location.

PROPOSED REPAIR
Machine the left side of the break above to the correct location per the drawing. This will blend into the area of the T that is currently undercut. Machine the T section on the right side of the break to match the flange surface that was cut off of location (approximately .100"). The slot width will finish at 2.350" rather than 2.250". In order to accommodate the oversized slot, the shim thickness will need to be machined to 2.225 rather than 2.125". The additional .100" of stock will be added to only one surface on the shim and profile machined accordingly (see picture on next page).

65707/5 (C5)
SE141-116

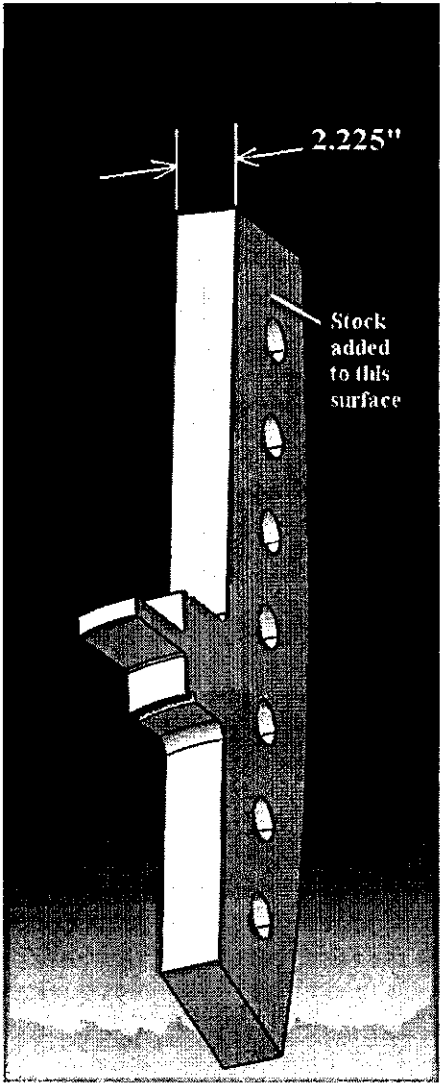

Customer: ENERGY INDUSTRIES OF OHIO

Contact: NANCY HORTON
E-Mail: NKHFlowen@aol.com

Telephone: 216-496-2314
Fax: 216-328-2001

Part: SE141-116 / MODULAR COIL WINDING FORM TYPE
Drawing ID: SE141-116 Revision: 8

Customer P.O.: S005242-F/Ln:5
Serial No./Qty: C5

Reported By: MIKE GRIFFITH
E-Mail: mGriffith@MajorTool.com

Telephone: 317-636-6433
Fax: 317-634-9420

**Problem: PART IS REJECTED PER ASTM A903/A903M LEVEL 1.
SEE ATTACHMENT FOR SIZES AND LOCATIONS.**

Proposed Disposition:
CUSTOMER TO ADVISE.

Number of additional pages: 11

Customer Disposition: Use As Is Rework Repair Scrap Replace

The defects indicated on the attached were reviewed in detail by David Williamson and Phil Heitzenroeder while communicating with Frank Malinowski, Roy Sheppard, and Mike Griffeth at MTM. MTM sent additional photos requested, and each defect was discussed in detail. Based on these discussions, it was jointly decided that the indications should be dispositioned as indicated in the attached Excel spreadsheet.

Approved by:

Phil
Heitzenroeder

Digitally signed by Phil Heitzenroeder
DN: cn = Phil Heitzenroeder, c = US,
o = PPPL, ou = Mech. Eng. Division
Reason: I agree to 'specified' portions
of this document
Date: 2006.04.19 17:52:27 -04'00'

Brad
Nelson

Digitally signed by Brad Nelson
DN: cn=Brad Nelson, c=US,
o=ORNL, ou=FED,
email=nelsonbe@ornl.gov
Date: 2006.04.19 21:59:39
-04'00'

Tech. Rep.

RLM

Mike
Griffith

Digitally signed by Mike Griffeth
DN: cn=Mike Griffeth, c=US, o=Major Tool
and Machine, ou=CFT - Weld,
email=mgriffeth@majortool.com
Reason: I agree to the terms defined by the
placement of my signature on this document
Date: 2006.04.28 11:28:22 -04'00'

Major Tool Implemented By: _____ Title: _____ Date: _____

PT Inspection Results of C5 – NC19587

MTM Workorder #: 65707/5.0

NC19587

SE141-116 C5 MODULAR COIL WINDING FORM TYPE-C

PENETRANT TEST: TYPE II, METHOD A, FORM E

REJECT INDICATIONS PER ASTM A903/A903M

1. Linear cluster, longest 1.250", side D, (1.130 diameter hole in foot)



2. Linear cluster, longest .450", under E flange, under small wing



3. Linear, length .300", on pad near lead block slot

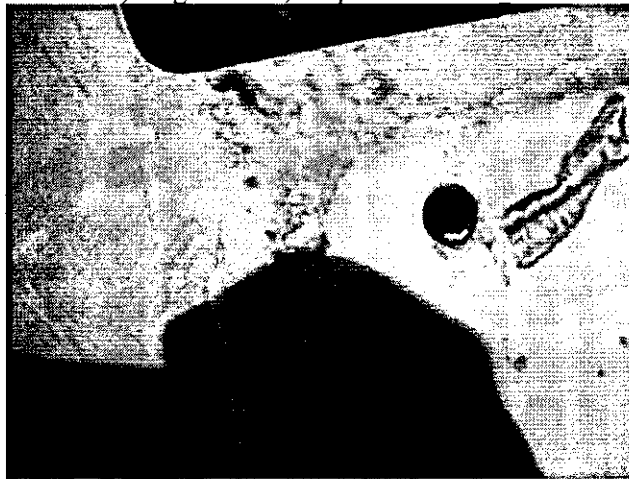

Mike Griffith

Page 1 of 11

4/14/2006



PT Inspection Results of C5 – NC19587

4. Linear cluster, longest .300", O.D. of D flange near hole 7

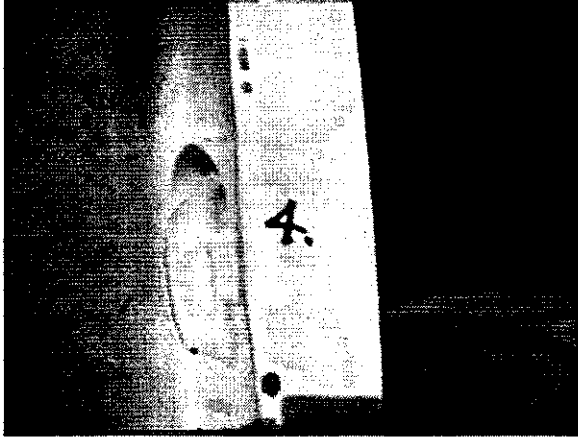

5. Linear length .500", D flange face near hole 16



6. Linear w/cluster porosity, longest .800", D-20



PT Inspection Results of C5 – NC19587

7. Linear (void), length .400"x .100", D-79 (bottom of cutout sheet 4, zone D5)

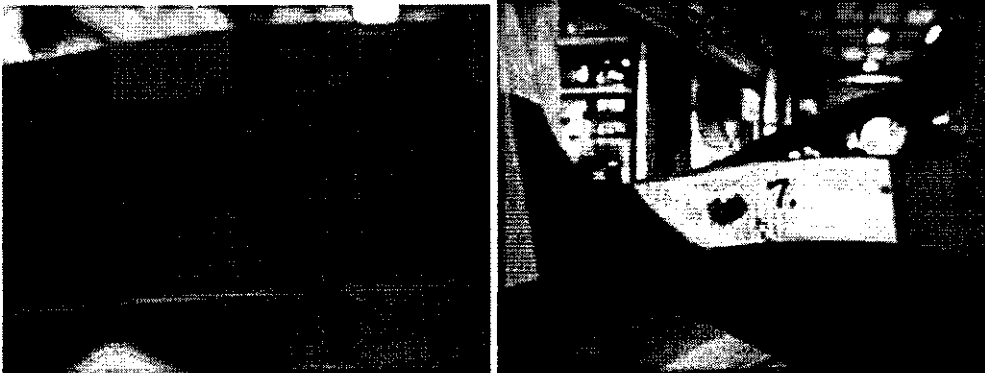

8. Linear, length 2.00", D-76 (between cooling holes sheet 9, zone D7)



9. Linear, .600" / rounded .125", D-75 (these are below VPI groove in high stress area)

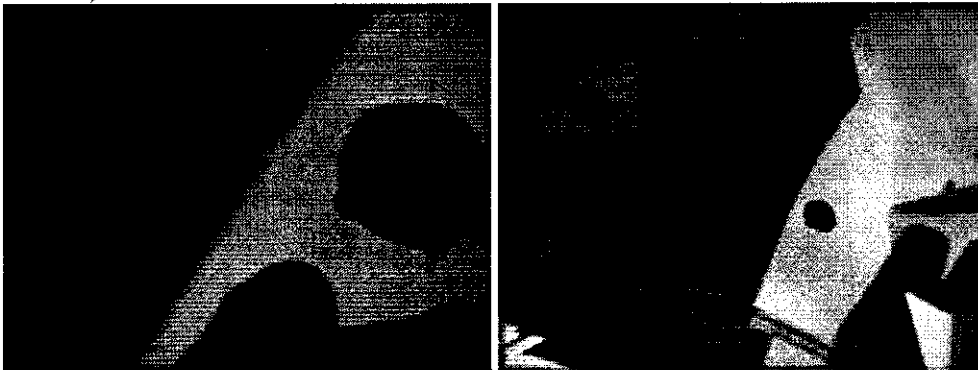

PT Inspection Results of C5 – NC19587

10. Linear cluster, longest .200", O.D. flange on leg, D-72



11. Linear (void) length .500", O.D. flange, E-64



12. Linear cluster w/porosity, longest .800", D-60 (outside of large wing surface)



PT Inspection Results of C5 – NC19587

13. Linear cluster w/porosity, longest .500" D-60

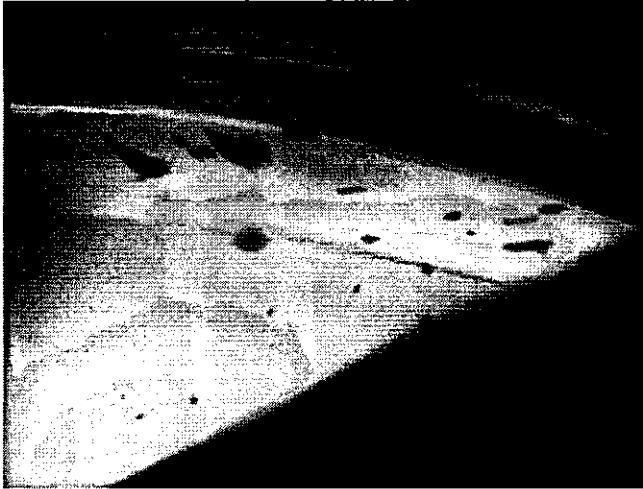

14. Linear, length .150", D-43

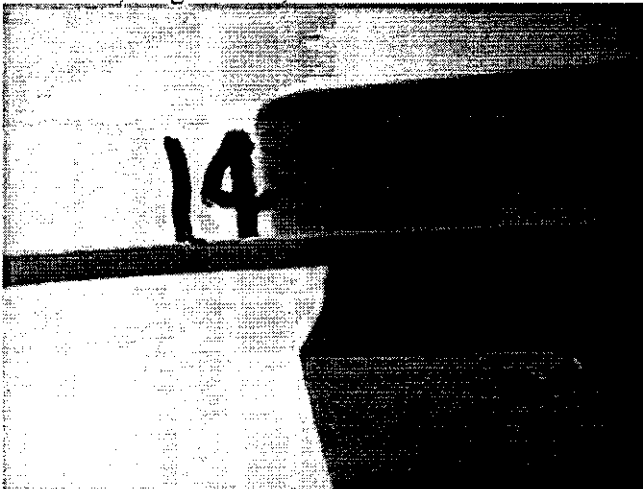

15. Linear cluster, longest .200", T-face, hole 48



PT Inspection Results of C5 – NC19587

16. Linear, length .200", T face, hole 61

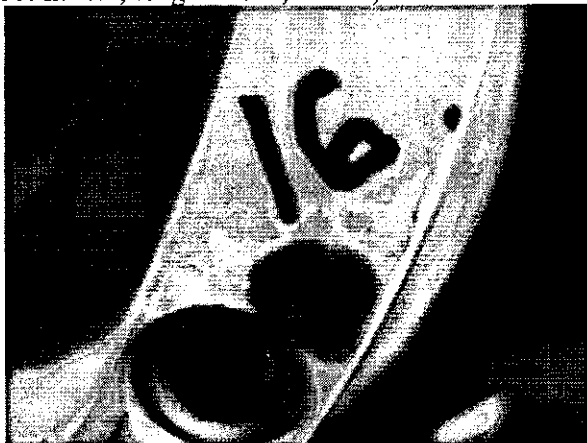

17. Linear cluster, longest .300", D-30

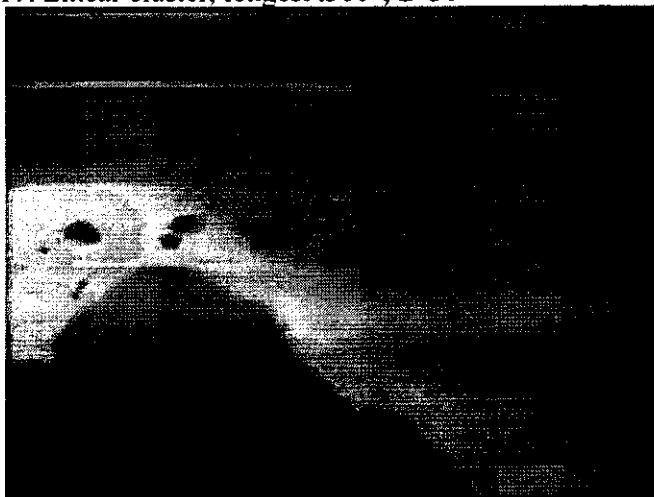

18. Linear cluster w/porosity, longest .200", D-22



Mike Griffith

Page 6 of 11

4/14/2006



PT Inspection Results of C5 – NC19587

19. Single rounded, .350", D-8 (this is on the long leg of the T near the face)



20. Linear, length .200", D-5

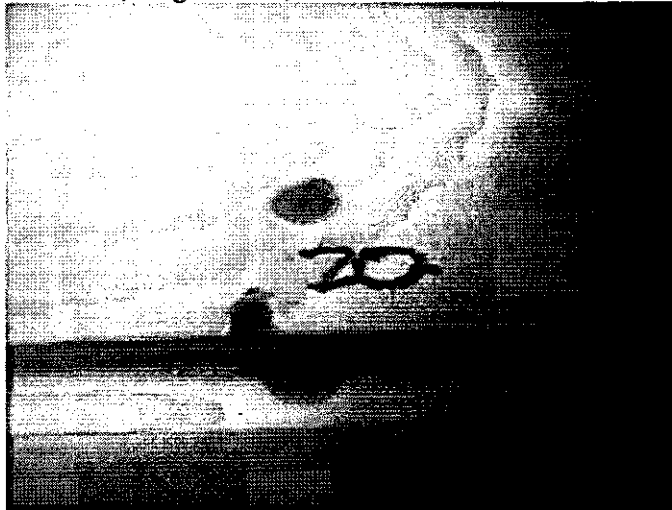

21. Linear cluster, longest .300", D-87

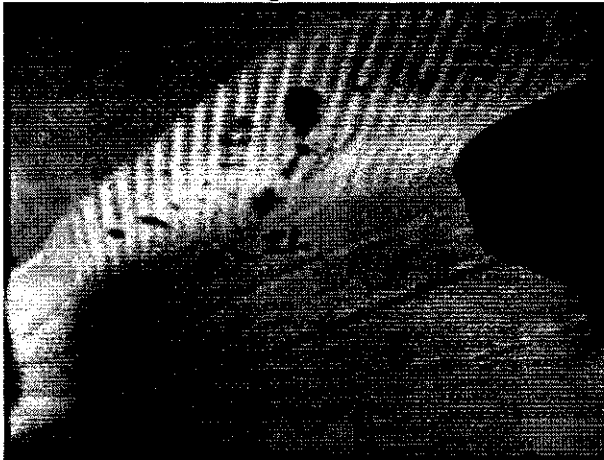

PT Inspection Results of C5 – NC19587

22. Linear, length .200", D-80

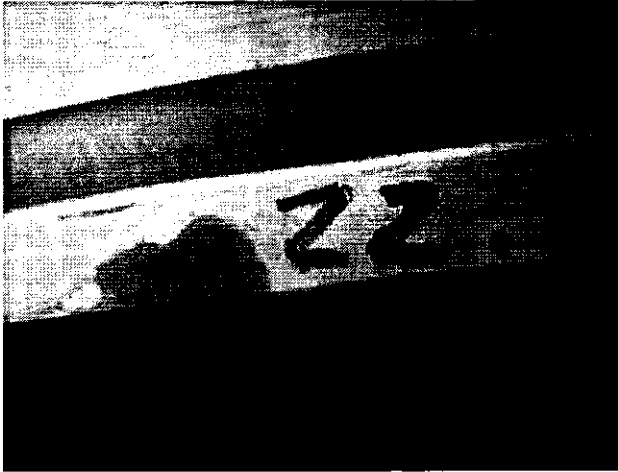

23. Linear w/porosity, longest .500", D face, 2" blind hole

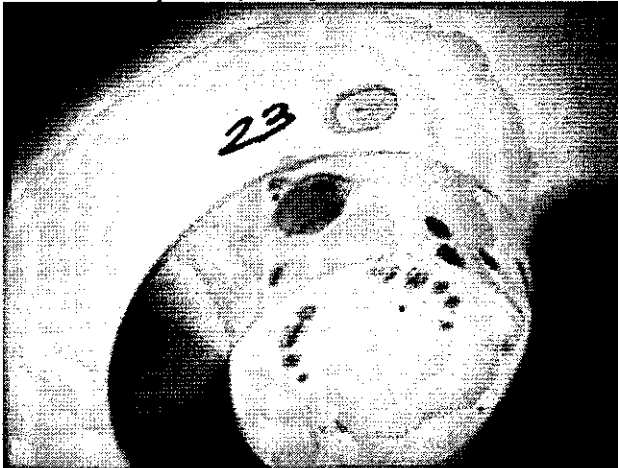

24. Linear, length 1.00", O.D. E flange 79



PT Inspection Results of C5 – NC19587

25. Linear, length .550", O.D. E flange 78



26. Linear cluster w/porosity, longest .200", E-60

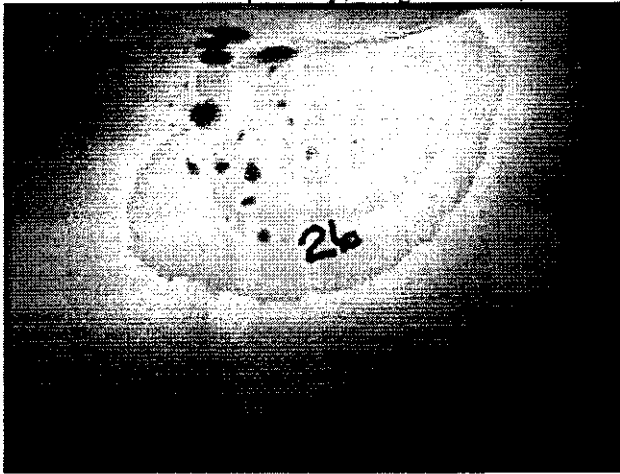

27. Rounded (void), length .150"x .600" depth

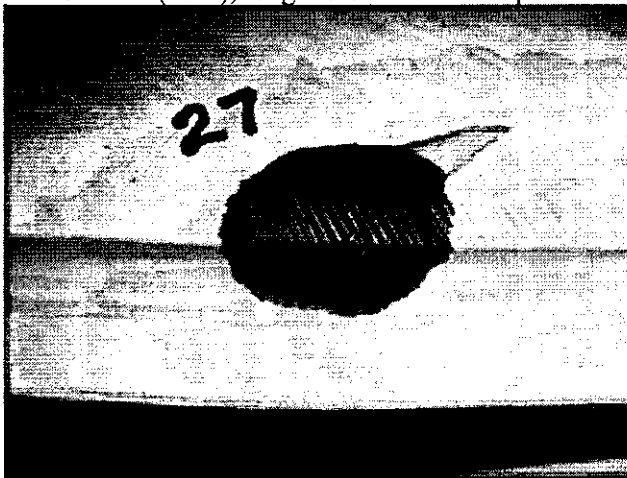

PT Inspection Results of C5 – NC19587

28. Linear cluster w/porosity, longest .600", E-55

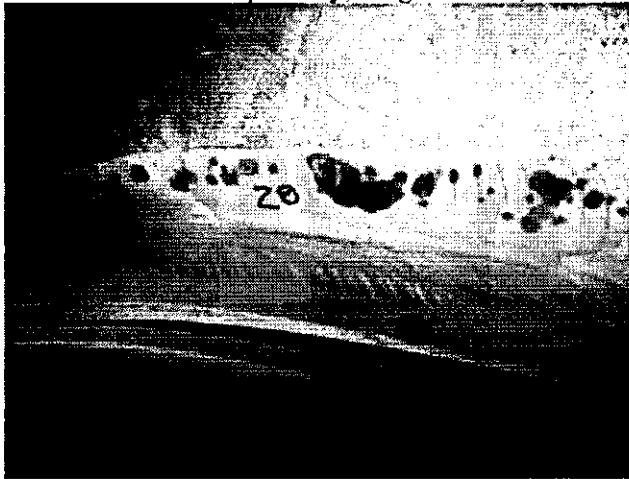

29. Linear cluster, longest .600", E-49

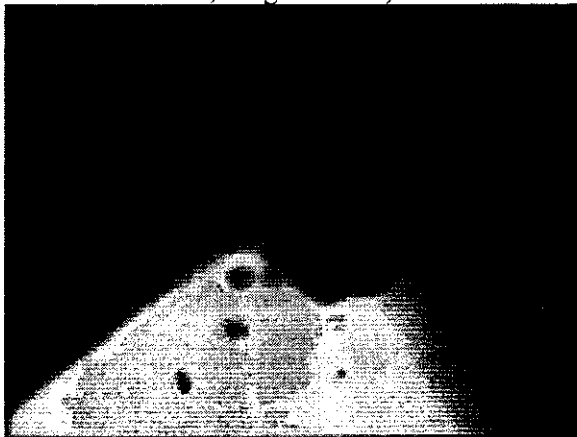

30. Linear (void), length .300" x .250" depth, E-4

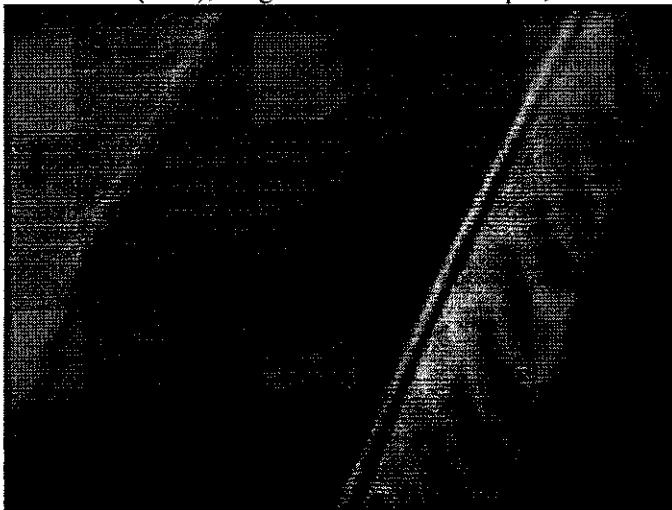

PT Inspection Results of C5 – NC19587

31. Linear cluster, longest .400", E-14



Mike Griffith

Page 11 of 11

4/14/2006



Resolution for C5 DP Indications

4/18/2006

4/19/2006

Indication # Initial Disposition

Final disposition

1 Grind	As is
2 Grind	As is
3 Grind	grind
4 As Is	As is
5 better view	As is
6 better view	As is
7 Grind	As is
8 Grind	grind
9 As Is	As is
10 better view	As is
11 better view	As is
12 Grind	As is
13 better view	As is
14 grind but be careful to leave corner!	As is
15 grind	As is
16 grind	As is
17 better view	As is
18 grind	As is
19 better view	As is
20 grind	As is
21 grind	grind
22 grind	As is
23 grind large indication under 23.	As is
24 grind	As is
25 grind	As is
26 better view	As is
27 grind carefully	As is
28 grind	As is
29 as is	As is
30 better view	As is
31 grind	As is

Customer: ENERGY INDUSTRIES OF OHIO

Contact: NANCY HORTON
 E-Mail: NKHFlowen@aol.com

Telephone: 216-496-2314
 Fax: 216-328-2001

Part: SE141-103-1 / MOD COIL WINDING FORM ASSEMBLY
 Drawing ID: MCWF TYPE-C XRAY MA Revision:

Customer P.O.: S005242-F/Ln:5
 Serial No./Qty: C5

Reported By: MIKE GRIFFITH
 E-Mail: mGriffith@MajorTool.com

Telephone: 317-636-6433
 Fax: 317-634-9420

Problem: The radiographic inspection performed on the "T" Section revealed eight (8) entrapped, gas-type discontinuities in film location 0-1.

An "overlay film" was made to represent the location of the indications as they could be found within the casting material.

See attachments:
 Reader Sheet
 RT Map
 Photos of overlay

Proposed Disposition:

Propose to Use As Is.

Number of additional pages: 5

Customer Disposition: Use As Is Rework Repair Scrap Replace

The attached Reader Sheet indicates that the (8) rejectable discontinuities are 0.090-0.110" (2.25-2.75 mm) in diameter. They are located roughly between holes 45 and 50. Since the stress in this region is <100 MPa, the discontinuities can be accepted "as is".

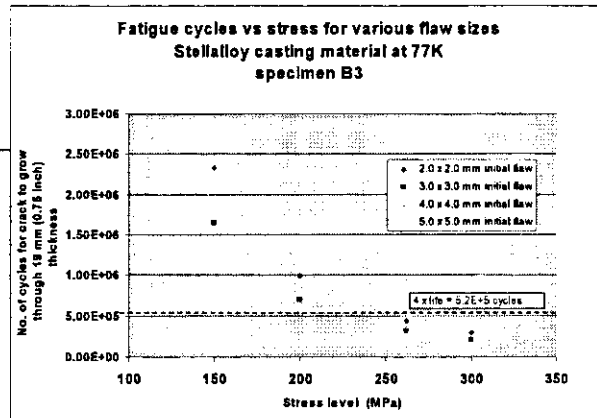
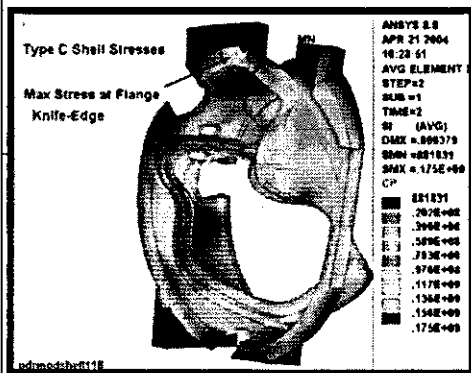

Accepted by:

Phil Heitzenroeder

Digitally signed by Phil Heitzenroeder
 DN: cn=Phil Heitzenroeder, c=US, o=PPPL, ou=Mech. Eng. Division
 Reason: I am the author of this document
 Date: 2006.04.19 17:35:39 -0400'

Brad Nelson

Digitally signed by Brad Nelson
 DN: cn=Brad Nelson, c=US, o=ORNL, ou=FED,
 email=nelsonbe@ornl.gov
 Date: 2006.04.24 11:35:50 -0400'

Tech. Rep.

RLM

Mike Griffith

Digitally signed by Mike Griffith
 DN: cn=Mike Griffith, c=US, o=Major Tool and Machine, ou=CFT - Whites, email=mgriffith@majortool.com
 Reason: I agree to the terms defined by the placement of my signature on this document
 Date: 2006.06.12 17:11:14 -0400'

Major Tool Implemented By: _____

Title: _____

Date: _____



4959
10520 Chester Road
Woodlawn, Ohio 45215

CLIENT Major Tool + Machine		INTERPRETER LEVEL Robert Weaver II		RADIOGRAPHER Robert Weaver		JOB NO 13860001	P.O. NO N/A	DATE 4/13/06		
ISOTOPE X-RAY IR192	DIAG. X LENGTH .118"x.089"	CURIES/MA 45	FOCAL SPOT SIZE .148"	SFD 18"	SOD 17.25"	TIME	FILM PROCESSING A,10	FILM TYPE Kodak AA	FILM TECHNIQUE Double	PB SCREENS .010"
WELD PROCESS N/A		MATERIAL SPEC. 316 SST		MATERIAL DIAMETER N/A		MATERIAL THICKNESS .75"	PENETRANT ASTM 1B		SHM N/A	ACCEPTANCE STANDARD No indications > .080"

DESCRIPTION
65707/5.0/1/110/818
SE141-116 rev.8
page 1 of 2

REMARKS
Densitometer - 12105
cal due - 5/2/06
8 spots .090"-.110" diameter / MTM ref. #19607 NCR

FITTING, SEAM OR FITTING	FILM INTERVAL NUMBER	WELDER IDENTIFICATION	PENETRANT		SLAG	POROSITY	POROSITY WITH TAIL	CRACK	LACK OF PEN	LACK FUSION	INTERNAL CONVEXITY	INTERNAL CONCAVITY	TUNGSTEN	MELT-THROUGH	BURN-THROUGH	CRATER PIT	OXIDATION	INTERNAL UNDERCUT	EXTERNAL UNDERCUT	ALIGNED INDICATIONS	WELD CONTOUR	MS-MATCH	FILM ARTIFACT	VISUAL CONCERNS	FILM DENSITY	SEE REMARKS	ACCEPT	REJECT
			SIZE	QUALITY LEVEL																								
T-area	0-1	N/A	1B	.016"		✓																			✓		X	
	1-2					✓																						
	2-3																									✓		
	3-4																									✓		

End View | Side View

SINGLE WALL

DOUBLE WALL

P Penetrant
 S Shm
 L Location Marker
 I OTHER

Robert Weaver 655514/II
Cooperheat-MQS Signature

[Signature]
Customer Representative Signature

4/13/06
Date

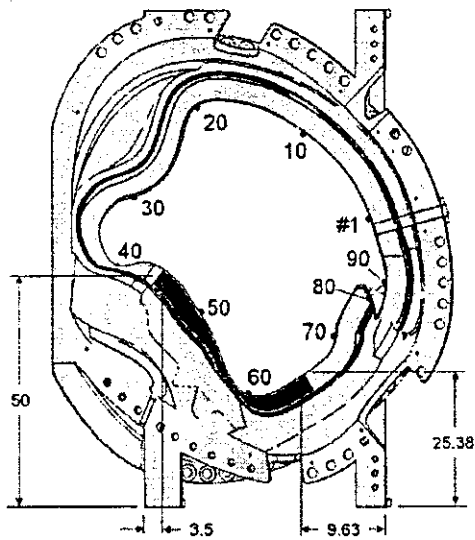

65707/5.0/1/1.0/818
SE141-116 rev.8
Page 2 of 2
4/13/06
NCR 19607

Figure 7-2 - High Stress Region Identification for Type-C MCWF

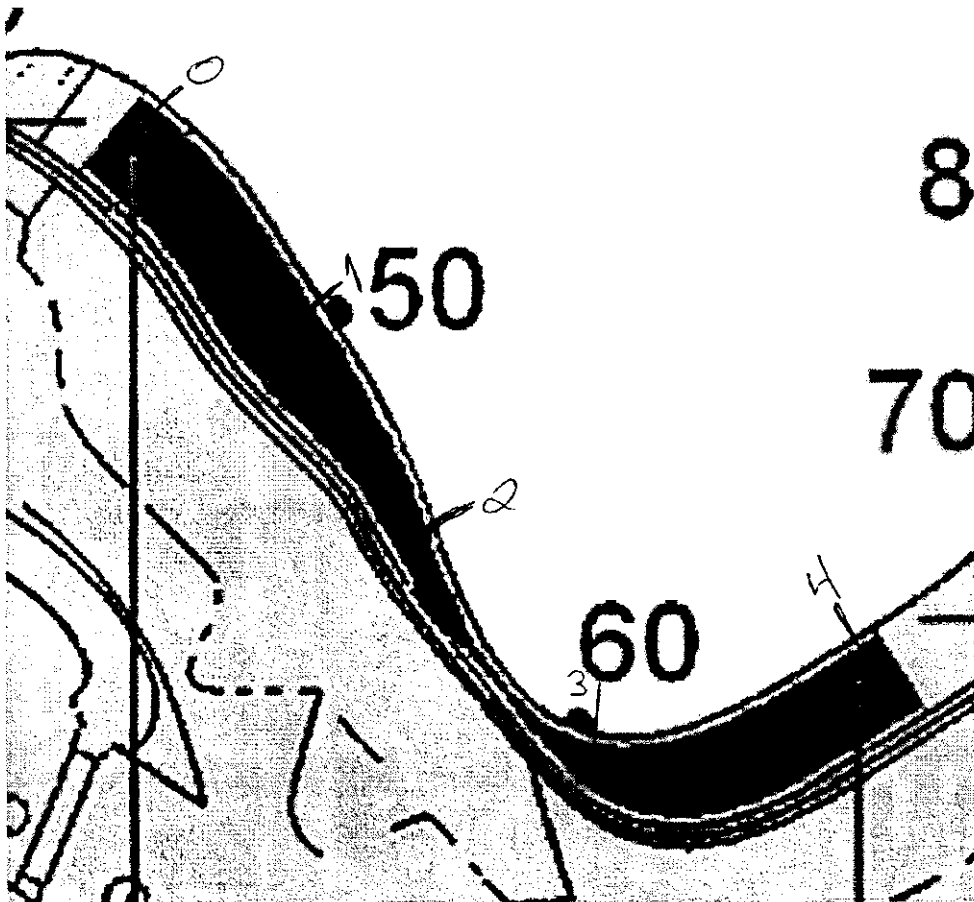

Customer: ENERGY INDUSTRIES OF OHIO

Contact: NANCY HORTON
E-Mail: NKHFlowen@aol.com

Telephone: 216-496-2314
Fax: 216-328-2001

Part: SE141-116 / MODULAR COIL WINDING FORM TYPE
Drawing ID: SE141-103 Revision: 3

Customer P.O.: S005242-F/Ln:5
Serial No./Qty: C5

Reported By: MIKE GRIFFITH
E-Mail: mGriffith@MajorTool.com

Telephone: 317-636-6433
Fax: 317-634-9420

Problem: SIX SEPARATE AREAS WERE IDENTIFIED FOR MINOR WELD REPAIR. THE LARGEST AREA WAS .300" LONG X .150 WIDE X .040" DEEP (IDENTIFIED AS WELD #5 IN THE ATTACHMENT).

Proposed Disposition:

PROPOSE TO ACCEPT AS IS AND WAIVE RT REQUIREMENT.
AFTER WELDING PT AND MAG PERMEABILITY CHECKS WERE COMPLETED AND DOCUMENTED.
THE GOUGES WERE SHALLOW TOOL GOUGES FROM ROUGH MACHINING.

Number of additional pages: 3

Customer Disposition: X Use As Is Rework Repair Scrap Replace

Since these were minor weld repairs, it is agreed that PT and mag permeability without RT is acceptable.

Approved by:

**Phil
Heitzenroeder**

Digitally signed by Phil Heitzenroeder
DN: CN = Phil Heitzenroeder, C = US,
O = PPPL, OU = Mech. Eng. Division
Reason: I agree to 'specified' portions
of this document
Date: 2006.04.27 14:54:28 -04'00'

**Brad
Nelson**

Digitally signed by Brad
Nelson
DN: cn=Brad Nelson, c=US,
o=ORNL, ou=FED,
email=nelsonbe@ornl.gov
Date: 2006.04.27 15:19:21
-04'00'

Tech. Rep.

RLM

**Mike
Griffith**

Digitally signed by Mike Griffith
DN: cn=Mike Griffith, c=US, o=Major
Tool and Machine, ou=CFT - White,
email=mgriffith@majortool.com
Reason: I agree to specified portions
of this document
Date: 2006.04.26 06:31:38 -04'00'

Major Tool Implemented By: _____

Title: _____

Date: _____

SE141-116 C5
Minor Weld Repairs / NC19710 attachment

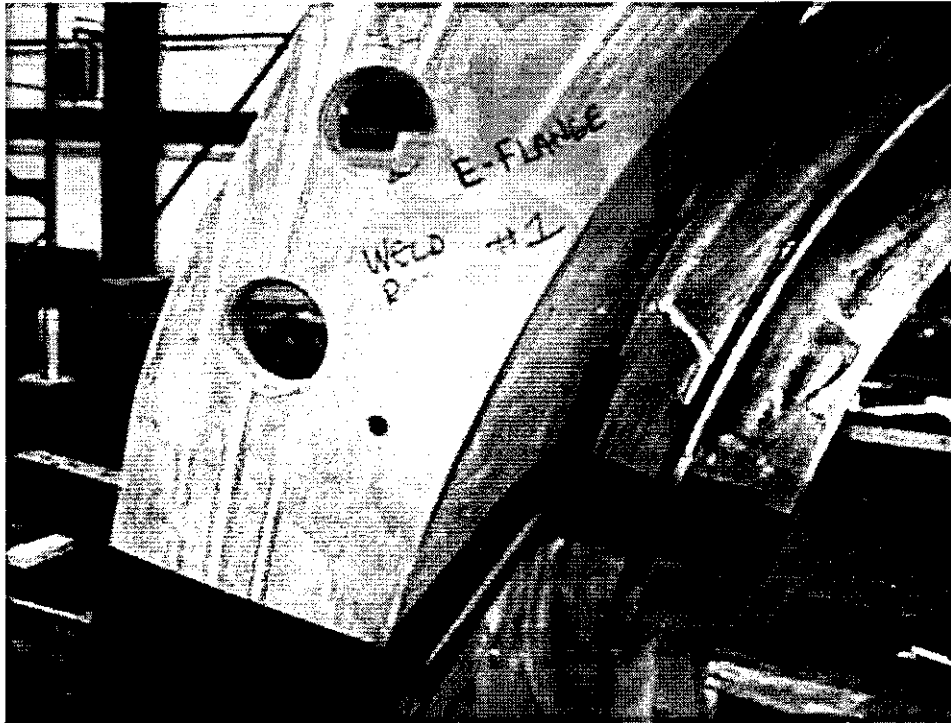

E Flange Face after Weld

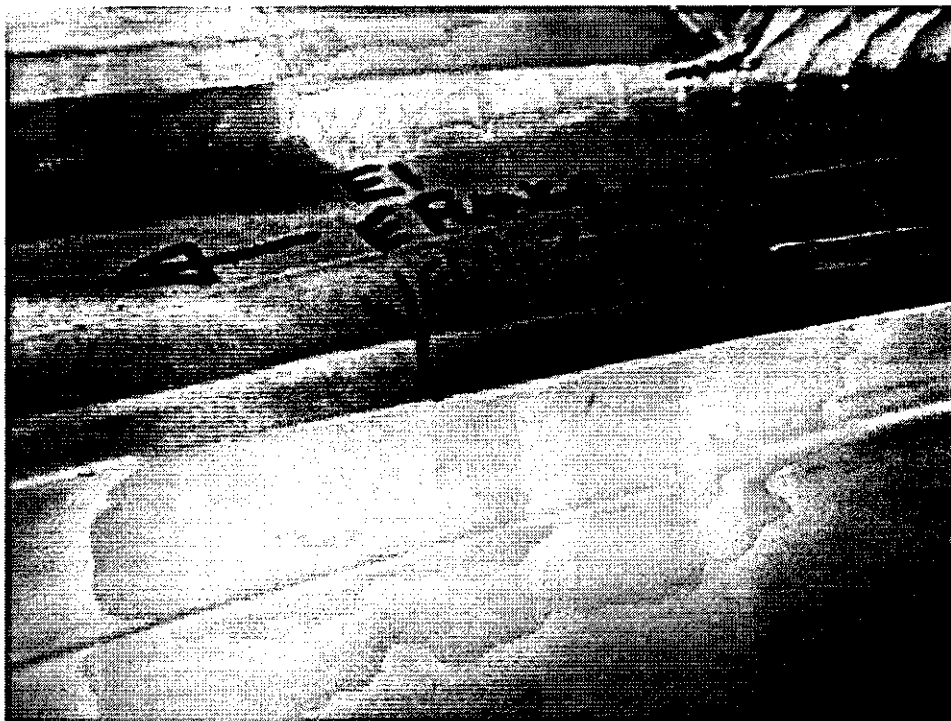

E Flange located by hole #1 near radius between long and short legs

Mike Griffith

Page 1 of 3

4/26/2006



Major
Tool & Machine, Inc.

SE141-116 C5
Minor Weld Repairs / NC19710 attachment



E Flange located by hole #76 near radius between long and short legs

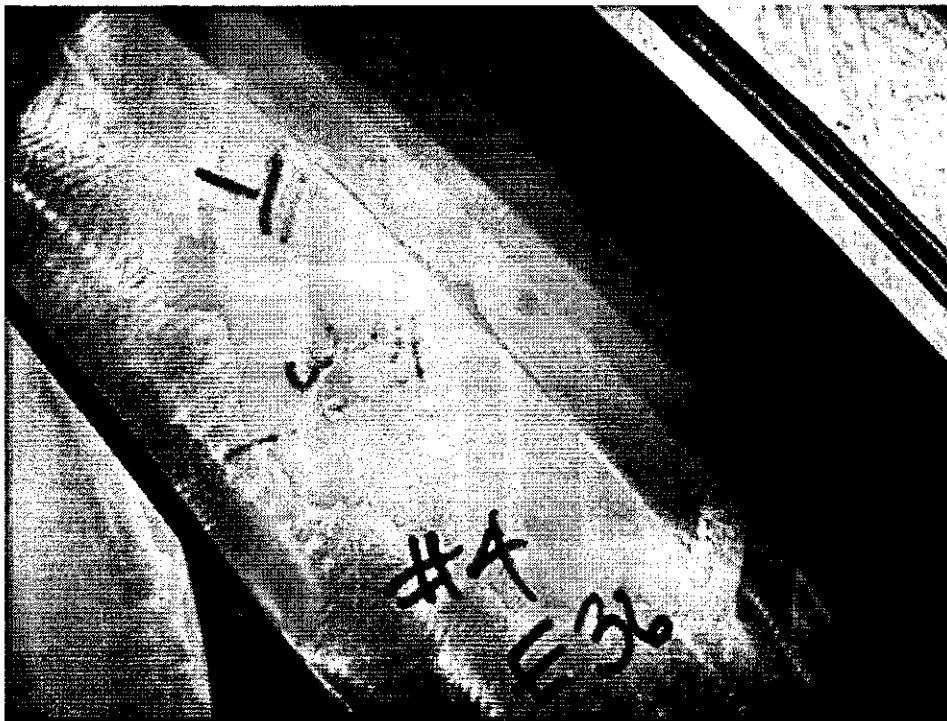

E Flange located by hole #36 near radius between long and short legs

Mike Griffith

Page 2 of 3

4/26/2006



Major
Tool & Machine, Inc.

SE141-116 C5
Minor Weld Repairs / NC19710 attachment

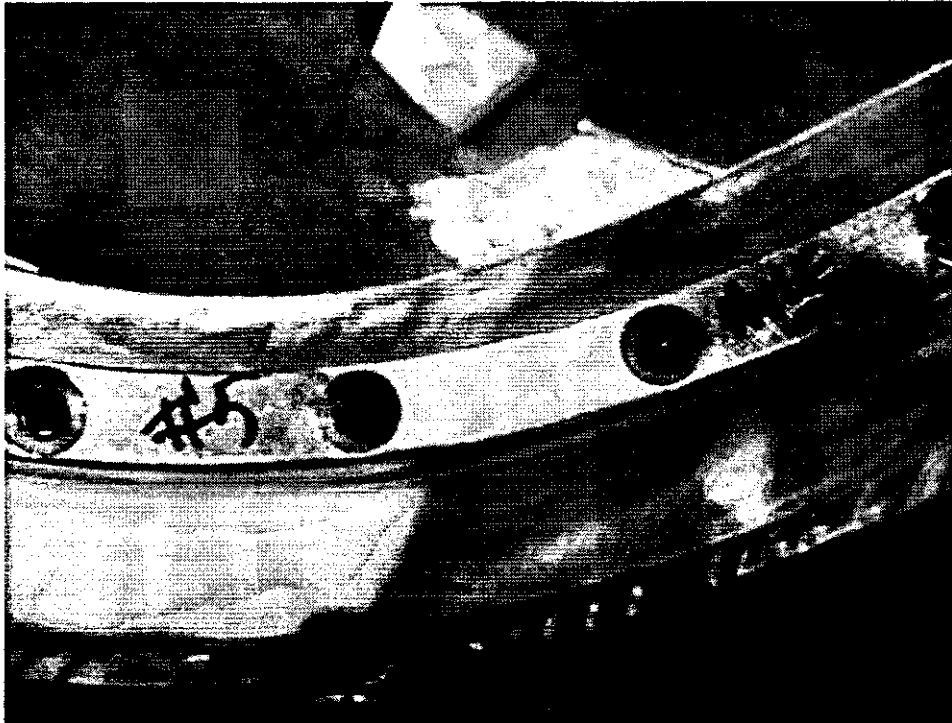

Top of T between holes 75 and 74



D Flange located by hole #48 near radius between long and short legs

Mike Griffith

Page 3 of 3

4/26/2006



Major
Tool & Machine, Inc.



Major

Tool & Machine, Inc.

Nondestructive Test Certification for Liquid Penetrant Examination

1458 E. 19th Street, Indianapolis, In 4621
TEL:(317)636-6433 FAX:(317)634-9420

Date of Inspection:04/24/2006

Type of Material:CAST STAINLESS

NDT#:16422

Stage of Inspection: <input type="checkbox"/> Incoming Inspection <input type="checkbox"/> In-Process Inspection <input checked="" type="checkbox"/> After Repair <input type="checkbox"/> Final Inspection	Manufacturing Process: <input type="checkbox"/> Weldment <input checked="" type="checkbox"/> Casting <input type="checkbox"/> Bar Stock <input type="checkbox"/> Plate <input type="checkbox"/> Forging <input type="checkbox"/> Other	Surface Condition: <input checked="" type="checkbox"/> Machined <input type="checkbox"/> Rough <input checked="" type="checkbox"/> Other BLENDED SMOOTH	Test Being Run to: <input checked="" type="checkbox"/> Router Instructions <input checked="" type="checkbox"/> Drawing <input type="checkbox"/> Test Plan <input type="checkbox"/> Technique Card SEE NOTES	Heat Treated: <input type="checkbox"/> Yes <input checked="" type="checkbox"/> No
--	--	--	---	--

Part Information: MTM Job Number: 65707/5.0 -Sub:14 -Op:20 Resource ID: 810-LIQUID PENETRANT INSPECTI Part ID: SE141-116 Part Name: MODULAR COIL WINDING FORM Serial Number: Customer P.O.: S005242-F Customer Unit/Plant:	Test Results: Quantity Inspected: 1 Quantity Accepted: 1 Quantity Rejected: 0 Run Hours:
--	---

Customer Inspection PI SEE NOTES Test Step: Revision: Material Test Number:	Inspection Criteria: Customer Specification: ASTM A903/A903M MTM Spec Number: PS582 (REF NDT-WM-09) Acceptance Standard: ASTM A903 (SEE NOTES)
---	--

Inspection Materials Used: Manufacturer: SHERWIN Type of Penetrant: DP-51 Batch Number: 41-E47 Developer: D-100 Batch Number: 520-H6	Penetrant Examination Processes: Type: II (Visible) / Dwell Time: 15 Minutes Method: C (Solvent Wipe) Method of Drying: Normal Evaporation Form: e (nonaqueous for Type II visible dye) / Dwell Time: 15 Min
--	---

Inspection Requirements:

% of all accessible surfaces Joint Preps Root Pass Back Gouge Cover Pass Other

Notes:

INSPECT WELD REPAIR AREAS, AS INSTRUCTED BY ENGINEERING.
SPECIFICATION: ASTM A903/A903M
METHOD: ASTM E165

ACCEPTANCE CRITERIA: ASTM A903/A903M LEVEL I FOR MACHINED SURFACES INCLUDING THE ENTIRE "T" SECTION (HIGH STRESS AREAS)

Note: Please reference NC 19710 for additional information.

This is to certify that the pieces specified have been inspected in accordance with the specifications shown.

Inspector: 581-D.EDWARDS

Date: 04/24/2006

Douglas D. Edwards Level II





INSPECTION DATA CHECKLIST

Workorder: 65707/5-0 Sub:14 Op:30

Revision: 04/25/06 16:40

Part: SE141-103-1 - -

Drawing ID: SE141-116 Rev: 8			INSPECTION INSTRUCTIONS			RESULTS		INSPECTED BY			
SHEET	ZONE	CHARACTERISTIC	GAGE/EQUIP	BY	SAMPLE	SER#	DATA/REMARKS	INSP	VERFD	AUDIT	
*		N C 19710 RECORD PERMEABILITY RANGE OF THE SIX REPAIRED AREAS. MAG PERMEABILITY TO BE NO GREATER THAN 1.02μ.	MASTER GAGE	QA		J-1165	LESS THAN 1.02	503-B.HO			A
(10)								04-26-06			*

Employees: 503-B.Houk

* To Far Right Indicates Data Package Requirement

NOTE: the recording of false, fictitious, or fraudulent statements or entries on this document may be punished as a felony under federal statutes including federal law, title 18, chapter 47.

Customer: ENERGY INDUSTRIES OF OHIO

Contact: NANCY HORTON
E-Mail: NKHFlowen@aol.com

Telephone: 216-496-2314
Fax: 216-328-2001

Part: SE141-116 / MODULAR COIL WINDING FORM TYPE
Drawing ID: SE141-116 Revision: 8

Customer P.O.: S005242-F/Ln:5
Serial No./Qty: C5

Reported By: MIKE GRIFFITH
E-Mail: mGriffith@MajorTool.com

Telephone: 317-636-6433
Fax: 317-634-9420

Problem: Workorder: 65707/5.0 Sub:1 Op:132

Inspection Test #: 180 rejected: M TO MI: {g|.02|R|S|T}: -.034 TO .038 (THESE ARE PRE-GRINDING RESULTS, SEE ATTACHMENT)

Inspection Test #: 182 rejected: N TO NI: {g|.02|R|S|T}: -.024 TO .030 (THESE ARE PRE-GRINDING RESULTS, SEE ATTACHMENT)

Inspection Test #: 190 rejected: 96X
.375-16 UNC .750 DEEP

.625 C'BORE .188 DEEP: {#.06|R|S|T}: .018 TO .075

Inspection Test #: 200 rejected: : 2X .06-.09 X 45': .06" TO .09 (SOME AREAS ARE ROUNDED DUE TO GRINDING)

Inspection Test #: 210 rejected: 8X Ø1-8 UNC THRU: {#.01|A|B|C}: .006 TO .043

Inspection Test #: 230 rejected: DATUM -E- FLANGE: {f|.01}: .019

Inspection Test #: 250 rejected: DATUM -D- FLANGE: {f|.01}: .037

Inspection Test #: 280 rejected: 8X

Ø1.13 THRU

BACK SPOT FACE Ø2.38

MIN DEPTH FOR C'UP: {#.01|A|B|C}: .003 TO .017 / ACCEPT SPOT

Inspection Test #: 291 rejected: 3X Ø1.885 +/- .003

Ø3.00 BACK SPOTFACE

VERIFY MIN CLEANUP: : 1.888 TO 1.892

Inspection Test #: 311 rejected: 3X Ø1.885 +/- .003 THRU

Ø3.00 BACK SPOTFACE

VERIFY MIN CLEANUP: : 1.888 TO 1.895

Inspection Test #: 361 rejected: Ø1.885 +/- .003 THRU

Ø3.00 BACK SPOTFACE

VERIFY MIN CLEANUP: : 1.890 / ACCEPT SPOT

Inspection Test #: 431 rejected: 24X Ø1.885 +/- .003 THRU

Ø3.00 BACK SPOTFACE

VERIFY MIN CLEANUP: : 1.882 TO 1.8893 / ACCEPT SPOT

Inspection Test #: 650 rejected: : 4.00 ~ .010: 3.960

Inspection Test #: 980 rejected: : {g|.125|A|B|C}: .0208 TO .2076

Inspection Test #: 990 rejected: DATUM -D- SIDE INNER CAST: {g|.5|A|B|C}: -.0006 TO -.3923

Inspection Test #: 1010 rejected: DATUM -E- SIDE LARGE WING: {g|.125|A|B|C}: .020 TO .101

Inspection Test #: 1030 rejected: DATUM -E- SIDE INNER CAST: {g|.5|A|B|C}: -.256 TO .258

Inspection Test #: 1035 rejected: MACHINE / GRIND THIS AREA
TO PROFILE OF +.05/- .10: : -.213 TO .495

Workorder: 65707/5.0 Sub:1 Op:130

Inspection Test #: 10 rejected: CHECK CLEARANCE OF ITEM 5 TO
ITEM 6.

: d.001 - d.002: DIAMETRICAL GAP CHECKS UP TO .022"

Proposed Disposition:

PROPOSE TO USE AS IS.

Number of additional pages: Grinding Attachment
and IDC lists

Approved by:

Customer Disposition: Use As Is Rework Repair Scrap Replace

The IDC list of various non-conformances and the results of the corrective grinding on the winding T surfaces were reviewed during a conference call on 4/28/05 attended by N. Horton, M. Griffith, R. Sheppard, T. Brown, J. Chrzanowski, D. Williamson, and P. Heitzenroeder. All were accepted for Use As Is with the exception of the poloidal break bushing to stud fit-ups, which need to be addressed at PPPL .

J. Chrzanowski is to apply cryogenic grade epoxy to the final studs for the poloidal breaks of C1-C5 to assure a zero clearance fit-up between the studs and bushings during replacement of the high permeability fasteners.

Accepted by:

Phil
Heitzenroeder

Digitally signed by Phil Heitzenroeder
DN: CN = Phil Heitzenroeder, C =
US, O = PPPL, OU = Mech. Eng.
Division
Reason: I agree to the terms defined
by the placement of my signature on
this document
Date: 2008.04.28 10:37:51 -04'00'

Brad
Nelson

Digitally signed by Brad
Nelson
DN: cn=Brad Nelson, c=US,
o=ORNL, ou=FED,
email=nelsonbe@ornl.gov
Date: 2006.04.28 13:54:07
-04'00'

Tech. Rep.

RLM

Mike
Griffith

Digitally signed by Mike Griffith
DN: cn=Mike Griffith, o=PPPL, ou=Mech. Eng. Division
Reason: I agree to the terms defined by the
placement of my signature on this document
Date: 2008.04.28 10:37:51 -04'00'

Major Tool Implemented By: _____ Title: _____ Date: _____

Workorder: 65707/5-0 Sub:1 Op:130

Revision:

Part: SE141-116 - MODULAR COIL WINDING FORM TYPE-C - PRODUCTION MODULAR COIL WINDING FORM TYPE-C

Drawing ID: SE141-103 Rev: 3			INSPECTION INSTRUCTIONS			RESULTS		INSPECTED BY			
SHEET	ZONE	CHARACTERISTIC	GAGE/EQUIP	BY	SAMPLE	SER#	DATA/REMARKS	INSP	VERFD	AUDIT	
2* (10)	D3	Ø.001 - Ø.002 CHECK CLEARANCE OF ITEM 5 TO ITEM 6.		QA		FEELER GAGE	DIAMETRICAL GAP CHE CKS UP TO .022"	242-M.G 04-26-06			R *
* (15)		THE GAP BETWEEN THE POLOIDAL BREAK BUSHINGS AND FLANGE SHAL BE LESS THAN .002"		QA		FEELER GAGE	ACCPET	242-M.G 04-26-06			A *
2* (20)	F2	ENSURE THAT THE CUMULATIVE GAP AT ANY SINGLE CROSS SECTION OF THE POLOIDAL FLANGE ELEMENTS IS LESS THAN .005".		QA		FEELER GAGE	LESS THAN .001"	242-M.G 04-26-06			A *
* (30)		THE MAX. GAP AT THE POLOIDAL BREAK PERIMETER IS .015" AND CANNOT EXCEED 1/8" FROM THE EDGE		QA		FEELER GAGE	MAX GAP IS .006"	242-M.G 04-26-06			A *

Employees: 242-M.Griffith

* To Far Right Indicates Data Package Requirement

NOTE: the recording of false, fictitious, or fraudulent statements or entries on this document may be punished as a felony under federal statutes including federal law, title 18, chapter 47.

QA003 (n:\vntmapps\mainspct.qpp)

Major Tool and Machine, Inc. 1458 East 19th Street, Indianapolis, IN 46218 (317)636-6433 Fax (317)634-9420

Workorder: 65707/5-0 Sub:1 Op:132

Revision:

Part: SE141-116 - MODULAR COIL WINDING FORM TYPE-C - PRODUCTION MODULAR COIL WINDING FORM TYPE-C

Drawing ID: SE141-116 Rev: 8			INSPECTION INSTRUCTIONS			RESULTS		INSPECTED BY		
SHEET	ZONE	CHARACTERISTIC	GAGE/EQUIP	BY	SAMPLE	SER#	DATA/REMARKS	INSP	VERFD	AUDIT
1* (10)	E8	47.19 ± .03	CMM	QA		00064	47.17	339-E.R 04-26-06		A *
1* (20)	B8	47.19 ± .03	CMM	QA		00064	47.18	339-E.R 04-26-06		A *
1* (30)	D6	47.19 ± .03	CMM	QA		00064	47.18	339-E.R 04-26-06		A *
1* (40)	C6	47.19 ± .03	CMM	QA		00064	47.19	339-E.R 04-26-06		A *
1* (50)	E6	∥ .02 A	CMM	QA		00064	.01	339-E.R 04-26-06		A *
1* (60)	B6	∥ .02 A	CMM	QA		00064	.02	339-E.R 04-26-06		A *
2* (80)	H6	2X R.187 +.025 -.005	PIN GAGE	QA		J-651-2	.184 TO .188	533-B.C 04-20-06		A *
2* (90)	G8	2X .03 X 45°		QA		VISUAL	ACCEPT	339-E.R 04-26-06		A *
2* (100)	G8	.40 ± .010	CALIPER	QA		J-707	.39 TO .41	339-E.R 04-26-06		A *
2* (110)	G8	2X .030 X 45°		QA		VISUAL	ACCEPT	339-E.R 04-26-06		A *
2* (120)	F7	2X .32	CALIPER	QA		P-5075	.310 TO .330	533-B.C 04-20-06		A *
2* (130)	F7	2X R.11	PIN GAGE	QA		J-652-1	.105 TO .110	533-B.C 04-20-06		A *
2* (140)	G6	⊖ .2 R S T P TO M	CMM	QA		00064	-.002 TO .086	339-E.R 04-26-06		A *
2*	G6	4.790 OR SHELL INTERSECT.		QA		MTMFX-3473	ACCEPT	339-E.R		A

* To Far Right Indicates Data Package Requirement

NOTE: the recording of false, fictitious, or fraudulent statements or entries on this document may be punished as a felony under federal statutes including federal law, title 18, chapter 47.

QA003 (n:\mtrapp\mtrinspct.qrp)

Major Tool and Machine, Inc. 1458 East 19th Street, Indianapolis, IN 46218 (317)636-6433 Fax(317)634-9420



INSPECTION DATA CHECKLIST

(150)		VERIFY USING TEMPLATE PER DRAWING NOTE 16 (MTMFX-3473)						04-26-06		*	
2* (160)	G3	\triangle 2 R S T Q TO N	CMM	QA		00064	-.003 TO .074	339-E.R 04-26-06		A *	
2* (170)	G3	4.790 OR SHELL INTERSECT. VERIFY USING TEMPLATE PER DRAWING NOTE 16 (MTMFX-3473)		QA		MTMFX-3473	ACCEPT	339-E.R 04-26-06		A *	
2* (180)	E6	\triangle .02 R S T M TO MI	CMM	QA		00064	-.034 TO .038	339-E.R 04-26-06		R *	
2* (182)	F3	\triangle .02 R S T N TO NI	CMM	QA		00064	-.024 TO .030	339-E.R 04-26-06		R *	
2* (185)	E5	\triangle .1 R S T MI TO NI	CMM	QA		00064	-.046 TO .019	339-E.R 04-26-06		A *	
Drawing ID: NCSX-CSPEC-141-03 Rev: 11			INSPECTION INSTRUCTIONS			RESULTS			INSPECTED BY		
SHEET	ZONE	CHARACTERISTIC	GAGE/EQUIP	BY	SAMPLE	SER#	DATA/REMARKS	INSP	VERFD	AUDIT	
4* (188)	3.1.1.	$\sqrt{125}$ THE TWO "L" MACHINED SURFACES OF TEE.	PROFILOMETER	QA		J-1109	33 TO 55	533-B.C 04-20-06		A *	
Drawing ID: SE141-116 Rev: 8			INSPECTION INSTRUCTIONS			RESULTS			INSPECTED BY		
SHEET	ZONE	CHARACTERISTIC	GAGE/EQUIP	BY	SAMPLE	SER#	DATA/REMARKS	INSP	VERFD	AUDIT	
2* (190)	B5	ϕ .06 R S T 96X .375-16 UNC .750 DEEP .625 C'BORE .188 DEEP	CMM	QA	50%	00064	.018 TO .075	339-E.R 04-26-06		R *	
2* (195)	B5	.375-16 UNC .750 DEEP GAGE 100% OF THE HOLES AND VERIFY CLEANLINESS.	THREAD PLUG GA	QA	100%	A-444	ACCEPT	339-E.R 04-26-06		A *	
2* (200)	B4	2X .06-.09 X 45°	CALIPER	QA		P-5075	.06" TO .09 (SOME A REAS ARE ROUNDED DU E TO GRINDING)	242-M.G 04-26-06		R *	
3* (210)	G7	ϕ .01 A B C 8X ϕ 1-8 UNC THRU	CMM	QA		00064	.006 TO .043	339-E.R 04-26-06		R *	
3*	H3	\square .01	CMM	QA		00064	.019	339-E.R		R	

* To Far Right Indicates Data Package Requirement

NOTE: the recording of false, fictitious, or fraudulent statements or entries on this document may be punished as a felony under federal statutes including federal law, title 18, chapter 47.
QA003 (n:\vtrnapp\mtnsptc.qrp)

Major Tool and Machine, Inc. 1458 East 19th Street, Indianapolis, IN 46218 (317)636-6433 Fax (317)634-9420

(230)		DATUM -E- FLANGE					04-26-06		*
3*	H4	✓ ²⁵	PROFILOMETER	QA	J-1109	6 TO 30	533-B.C		A
(240)		DATUM -E- FLANGE					04-20-06		*
3*	F3	∠ 01	CMM	QA	00064	.037	339-E.R		R
(250)		DATUM -D- FLANGE					04-26-06		*
3*	F3	✓ ²⁵	PROFILOMETER	QA	J-1109	25 TO 79	533-B.C		A
(260)		DATUM -D- FLANGE					04-20-06		*
3*	E4	⊕ .01 A B C 8X Ø1.13 THRU BACK SPOT FACE Ø2.38 MIN DEPTH FOR C'UP	CMM	QA	00064	.003 TO .017 / ACCE PT SPOT	339-E.R		R
(280)					MTMFX-3564		04-26-06		*
4*	H8	⊕ .060 D A N 3X Ø1.885 THRU	CMM	QA	00064	.039 TO .043	339-E.R		A
(290)							04-26-06		*
4*	H8	3X Ø1.885 +/- .003 Ø3.00 BACK SPOTFACE VERIFY MIN CLEANUP	CMM	QA	00064	1.888 TO 1.892	533-B.C		R
(291)			DIAL BORE GAGE		J-1400		04-20-06		*
4*	H7	⊕ Ø.06 D A N 3X 2.000" COUNTERBORE 1.00 DP	CMM	QA	00064	.020 TO .022	339-E.R		A
(300)							04-26-06		*
4*	H7	Ø 2.000 - 2.001	DIAL BORE GAGE	QA	J-1401	1.999 TO 2.001	339-E.R		A
(305)							04-26-06		*
4*	H6	⊕ Ø.060 D A N 17X Ø1.885 THRU	CMM	QA	00064	.035 TO .055	339-E.R		A
(310)							04-26-06		*
4*	H6	3X Ø1.885 +/- .003 THRU Ø3.00 BACK SPOTFACE VERIFY MIN CLEANUP	CMM	QA	00064	1.888 TO 1.895	533-B.C		R
(311)			DIAL BORE GAGE		J-1400		04-20-06		*
4*	H5	⊕ Ø.060 D A N 3X Ø1.13	CMM	QA	00064	.015 TO .020	339-E.R		A
(320)							04-26-06		*
4*	H5	3X Ø1.13 +/- .010 Ø2.38 BACK SPOTFACE VERIFY MIN CLEANUP	CMM	QA	00064	1.1248 TO 1.1278	533-B.C		A
(321)							04-20-06		*
4*	E6	⊕ Ø.060 D A N	CMM	QA	00064	.026 TO .044	339-E.R		A

* To Far Right Indicates Data Package Requirement

NOTE: the recording of false, fictitious, or fraudulent statements or entries on this document may be punished as a felony under federal statutes including federal law, title 18, chapter 47.
QA003 (n:\mtrapp\mtnsnpct.qrp) Major Tool and Machine, Inc. 1458 East 19th Street, Indianapolis, IN 46218 (317)636-6433 Fax (317)634-9420

(340)		3X Ø1.375-6 UNC THRU					04-26-06		*
4*	E6	⊕ Ø.060 D A N	CMM	QA	00064	.052 TO .056	339-E.R		A
(350)		5X Ø1.885 THRU					04-26-06		*
4*	E6	5X Ø1.885 +/- .003 THRU Ø3.00 BACK SPOTFACE VERIFY MIN CLEANUP	CMM	QA	00064	1.8857 TO 1.888 / A CCEPT SPOT	339-E.R		A
(351)					MTMFX-3564		04-26-06		*
4*	D4	⊕ Ø.060 D A N	CMM	QA	00064	.057	339-E.R		A
(360)		Ø1.885 THRU					04-26-06		*
4*	D4	Ø1.885 +/- .003 THRU Ø3.00 BACK SPOTFACE VERIFY MIN CLEANUP	CMM	QA	00064	1.890 / ACCEPT SPOT	339-E.R		R
(361)			DIAL BORE GAGE		J-1400		04-26-06		*
4*	B5	⊕ Ø.060 D A N	CMM	QA	00064	.005 TO .017	339-E.R		A
(370)		3X Ø1.13					04-26-06		*
4*	B5	3X Ø1.13 +/- .010 Ø2.38 BACK SPOTFACE VERIFY MIN CLEANUP	CMM	QA	00064	1.1253 TO 1.1255 / ACCEPT SPOT	339-E.R		A
(371)					MTMFX-3564		04-26-06		*
4*	D1	12X .25-20 UNC -2B	THREAD PLUG GA	QA	A-234	ACCEPT	533-B.C		A
(375)							04-20-06		*
4*	G8	⊕ Ø.06 D A N	CMM	QA	00064	.009 TO .031	339-E.R		A
(376)		12X .25-20 UNC -2B SUMMARY OF HOLE POSITIONS. ACTUAL FEATURE CONTROL FRAME IS NOT ON DRAWING.					04-26-06		*
5*	E8	⊕ Ø.060 E A J	CMM	QA	00064	.007	339-E.R		A
(380)		Ø1.885 THRU					04-26-06		*
5*	E8	Ø1.885 +/- .003 THRU Ø3.00 BACK SPOTFACE VERIFY MIN CLEANUP	CMM	QA	00064	1.888 / ACCEPT SPOT	339-E.R		A
(381)					MTMFX-3564		04-26-06		*
5*	F6	⊕ Ø.060 E A J	THREAD PLUG GA	QA	A-375	ACCEPT	533-B.C		A
(400)		3X Ø1.375-6 UNC THRU					04-20-06		*
5*	F6	⊕ Ø.06 E A J	CMM	QA	00064	.009 TO .019	339-E.R		A

* To Far Right Indicates Data Package Requirement

NOTE: the recording of false, fictitious, or fraudulent statements or entries on this document may be punished as a felony under federal statutes including federal law, title 18, chapter 47.
QA003 (n:\mtrapp\mtrapp\inspct.qrp)

Major Tool and Machine, Inc. 1458 East 19th Street, Indianapolis, IN 46218 (317)636-6433 Fax(317)634-9420

(410)		3X 2.000" COUNTERBORE 1.00 DP					04-26-06		*
5*	F6	∅ 2.000 - 2.001	DIAL BORE GAGE	QA	J-1401	1.999 TO 2.001	339-E.R		A
(412)							04-26-06		*
5*	F7		THREAD PLUG GA	QA	A-715	ACCEPT	339-E.R		A
(415)		7X 1/4-20 UNC -2B					04-26-06		*
5*	F7	∅ ∅.06 [E A J]	CMM	QA	00064	.006 TO .028	339-E.R		A
(420)		7X 1/4-20 UNC -2B SUMMARY OF HOLE POSITIONS. ACTUAL FEATURE CONTROL FRAME IS NOT ON DRAWING.					04-26-06		*
5*	E7	∅ ∅.060 [E A J]	CMM	QA	00064	.005 TO .023	339-E.R		A
(430)		24X ∅1.885 THRU					04-26-06		*
5*	E7	24X ∅1.885 +/- .003 THRU ∅3.00 BACK SPOTFACE VERIFY MIN CLEANUP	CMM	QA	00064	1.882 TO 1.8893 / A CCEPT SPOT	339-E.R		R
(431)			DIAL BORE GAGE		J-1400		04-26-06		*
5*	E7	∅ ∅.060 [E A J]	CMM	QA	00064	.010 TO .016	339-E.R		A
(440)		3X ∅1.5 TO 2.00 DEEP ∅3.00 TO 1.00 DEEP					04-26-06		*
5*	D7	3X ∅1.885 +/- .003 THRU ∅3.00 BACK SPOTFACE VERIFY MIN CLEANUP	CMM	QA	00064	1.883 TO 1.886 / AC CEPT SPOT	339-E.R		A
(450)					MTMFX-3564		04-26-06		*
6*	E3		PIN GAGE	QA	J-921	1.0	533-B.C		A
(470)		4X ∅1.00 THRU					04-20-06		*
8*	G7	4.00 ± .010	CALIPER	QA	J-1389	3.960	533-B.C		R
(650)							04-20-06		*
8*	D7	6X ∅.375-16 UNC TO .75 DEEP .03 X 45° CHAMFER	THREAD PLUG GA	QA	A-444	ACCEPT	339-E.R		A
(750)					VISUAL		04-26-06		*
8*	D7	13.6 °		QA	VISUAL	SEE IGES	339-E.R		A
(760)							04-26-06		*
8*	D7	5.88 VERIFY THAT PAD MEETS THE	CALIPER	QA	J-1389	6.900	533-B.C		A

* To Far Right Indicates Data Package Requirement

NOTE: the recording of false, fictitious, or fraudulent statements or entries on this document may be punished as a felony under federal statutes including federal law, title 18, chapter 47.

QA003 (n:\ntmapps\mainspct.qrp)

Major Tool and Machine, Inc. 1458 East 19th Street, Indianapolis, IN 46218 (317)636-6433 Fax(317)634-9420

(770)		MINIMUM OF 5.88						04-20-06		*
8* (780)	D7	2.19 ± .010		QA		VISUAL	SEE IGES	339-E.R 04-26-06		A *
8* (790)	D7	2.19 ± .010		QA		VISUAL	SEE IGES	339-E.R 04-26-06		A *
8* (830)	C8	2X 1.56 ± .010 THRU	CALIPER	QA		J-1389	1.555 TO 1.565	533-B.C 04-20-06		A *
8* (850)	C8	2X 7.50 ± .010 THRU	CALIPER	QA		J-1389	7.495 TO 7.502	533-B.C 04-20-06		A *
8* (860)	C8	8X R.25	PIN GAGE	QA		J-652-1	.250	533-B.C 04-20-06		A *
8* (870)	C8	2X 2.52 ± .010	CMM	QA		00064	SEE IGES	339-E.R 04-26-06		A *
9* (900)	E7	2.54 ± .010	SCALE	QA		J-922	ACCEPT	339-E.R 04-26-06		A *
9* (910)	E7	5.08 ± .010	SCALE	QA		J-922	5.08	339-E.R 04-26-06		A *
9* (920)	F3	4X Ø1.0 THRU VERIFY THAT HOLES BREAK COMPLETELY THROUGH INSIDE OF CASTING	PIN GAGE	QA		J-921	1.0	533-B.C 04-20-06		A *
9* (930)	F3	2X Ø .50 ± .010 THRU	PIN GAGE	QA		J-652-3	.500	533-B.C 04-20-06		A *
9* (940)	E3	2.44 ± .010	SCALE	QA		J-922	2.45	339-E.R 04-26-06		A *
9* (950)	E3	1.22 ± .010	SCALE	QA		J-922	ACCEPT	339-E.R 04-26-06		A *
9* (960)	C7	4X Ø1.0 THRU VERIFY THAT HOLES BREAK COMPLETELY THROUGH INSIDE OF CASTING	PIN GAGE	QA		J-921	1.0	533-B.C 04-20-06		A *
9* (970)	C6	2X Ø.25 T.C. HOLE	PIN GAGE	QA		J-652-1	.250	533-B.C 04-20-06		A *

* To Far Right Indicates Data Package Requirement

NOTE: the recording of false, fictitious, or fraudulent statements or entries on this document may be punished as a felony under federal statutes including federal law, title 18, chapter 47.
QA003 (n:\mtrapp\smh\insp.ct.gpr)

Major Tool and Machine, Inc. 1458 East 19th Street, Indianapolis, IN 46218 (317)636-6433 Fax (317)634-9420



INSPECTION DATA CHECKLIST

Drawing ID: SE141-116 Rev: 7			INSPECTION INSTRUCTIONS			RESULTS		INSPECTED BY			
SHEET	ZONE	CHARACTERISTIC	GAGE/EQUIP	BY	SAMPLE	SER#	DATA/REMARKS	INSP	VERFD	AUDIT	
10* (980)	C8	.125 A B C	CMM	QA		00064	.0208 TO .2076	339-E.R 04-26-06			R *
Drawing ID: SE141-116 Rev: 8			INSPECTION INSTRUCTIONS			RESULTS		INSPECTED BY			
SHEET	ZONE	CHARACTERISTIC	GAGE/EQUIP	BY	SAMPLE	SER#	DATA/REMARKS	INSP	VERFD	AUDIT	
10* (990)	D5	5 A B C DATUM -D- SIDE INNER CAST	CMM	QA		00064	-.0006 TO -.3923	339-E.R 04-26-06			R *
Drawing ID: SE141-116 Rev: 7			INSPECTION INSTRUCTIONS			RESULTS		INSPECTED BY			
SHEET	ZONE	CHARACTERISTIC	GAGE/EQUIP	BY	SAMPLE	SER#	DATA/REMARKS	INSP	VERFD	AUDIT	
10* (1010)	C4	.125 A B C DATUM -E- SIDE LARGE WING	CMM	QA		00064	.020 TO .101	339-E.R 04-26-06			R *
Drawing ID: SE141-116 Rev: 8			INSPECTION INSTRUCTIONS			RESULTS		INSPECTED BY			
SHEET	ZONE	CHARACTERISTIC	GAGE/EQUIP	BY	SAMPLE	SER#	DATA/REMARKS	INSP	VERFD	AUDIT	
10* (1030)	D1	5 A B C DATUM -E- SIDE INNER CAST	CMM	QA		00064	-.256 TO .258	339-E.R 04-26-06			R *
Drawing ID: SE141-116 Rev: 7			INSPECTION INSTRUCTIONS			RESULTS		INSPECTED BY			
SHEET	ZONE	CHARACTERISTIC	GAGE/EQUIP	BY	SAMPLE	SER#	DATA/REMARKS	INSP	VERFD	AUDIT	
10* (1035)	E1	MACHINE / GRIND THIS AREA TO PROFILE OF +.05/- .10	CMM	QA		00064	-.213 TO .495	339-E.R 04-26-06			R *
Drawing ID: NCSX-CSPEC-141-03 Rev: 10			INSPECTION INSTRUCTIONS			RESULTS		INSPECTED BY			
SHEET	ZONE	CHARACTERISTIC	GAGE/EQUIP	BY	SAMPLE	SER#	DATA/REMARKS	INSP	VERFD	AUDIT	
4* (1040)	3.1.1.	UOS ALL MACHINED SURFACES TO BE 250 RMS SURFACE FINISH RECORD RANGE	PROFILOMETER	QA		J-1109	150 TO 250	242-M.G 04-26-06			A *
Drawing ID: SE141-116 Rev: 8			INSPECTION INSTRUCTIONS			RESULTS		INSPECTED BY			
SHEET	ZONE	CHARACTERISTIC	GAGE/EQUIP	BY	SAMPLE	SER#	DATA/REMARKS	INSP	VERFD	AUDIT	
1* (1050)		NOTE 9 RECORD THE WEIGHT OF THE PART 6000LBS MAX	SCALE	QA		2270	5,580	242-M.G 04-26-06			A *

* To Far Right Indicates Data Package Requirement

NOTE: the recording of false, fictitious, or fraudulent statements or entries on this document may be punished as a felony under federal statutes including federal law, title 18, chapter 47.

QA003 (n:\mtrapp\mtrinspct.qrp)

Major Tool and Machine, Inc. 1458 East 19th Street, Indianapolis, IN 46218 (317)636-6433 Fax (317)634-9420



INSPECTION DATA CHECKLIST

Employees: 242-M.Griffith / 339-E.Root / 533-B.Clevenger

* To Far Right Indicates Data Package Requirement

NOTE: the recording of false, fictitious, or fraudulent statements or entries on this document may be punished as a felony under federal statutes including federal law, title 18, chapter 47.

QA003 (n:\ntmapps\minspect.qrp)

Major Tool and Machine, Inc. 1458 East 19th Street, Indianapolis, IN 46218 (317)636-6433 Fax(317)634-9420

Datum-D tee web between holes 65 and 69

Data indicates C5 high spots beyond $\pm .020$ -in profile tolerance

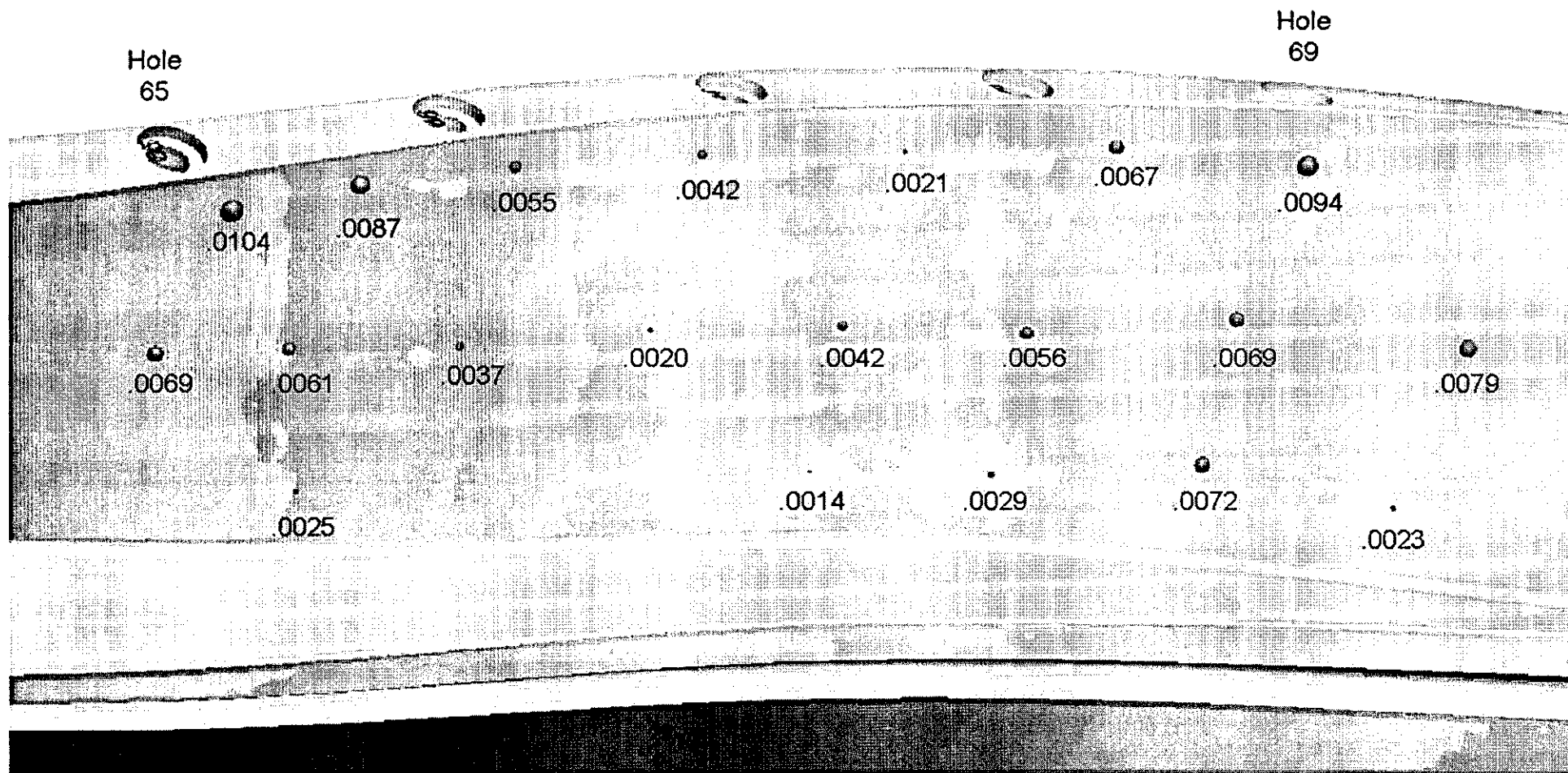

Datum-D tee base between holes 20 and 23

Data indicates C5 high spots beyond +/- .020-in profile tolerance

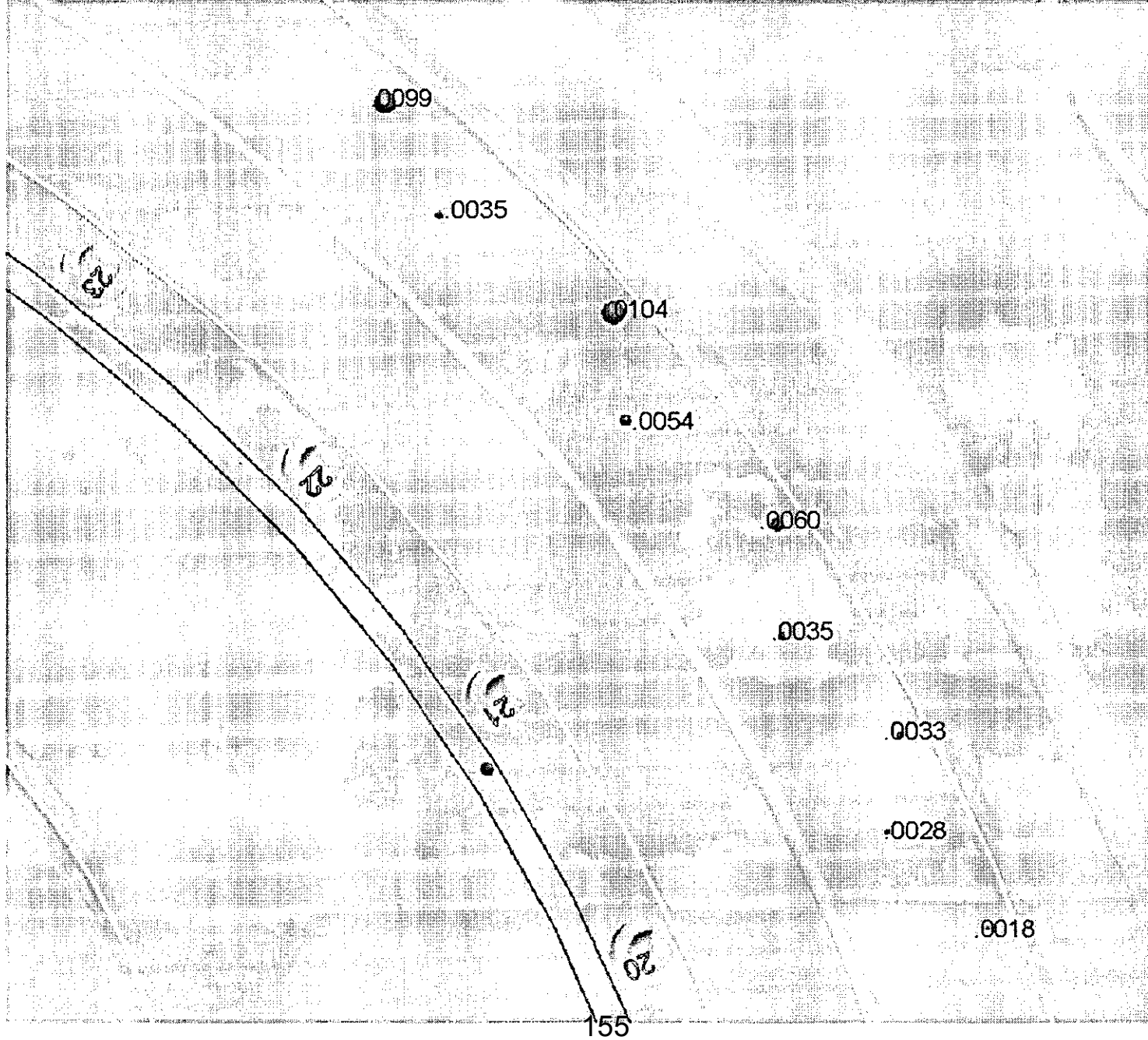

Datum-E tee base between holes 69 and 77

Data indicates C5 high spots beyond +/- .020-in profile tolerance

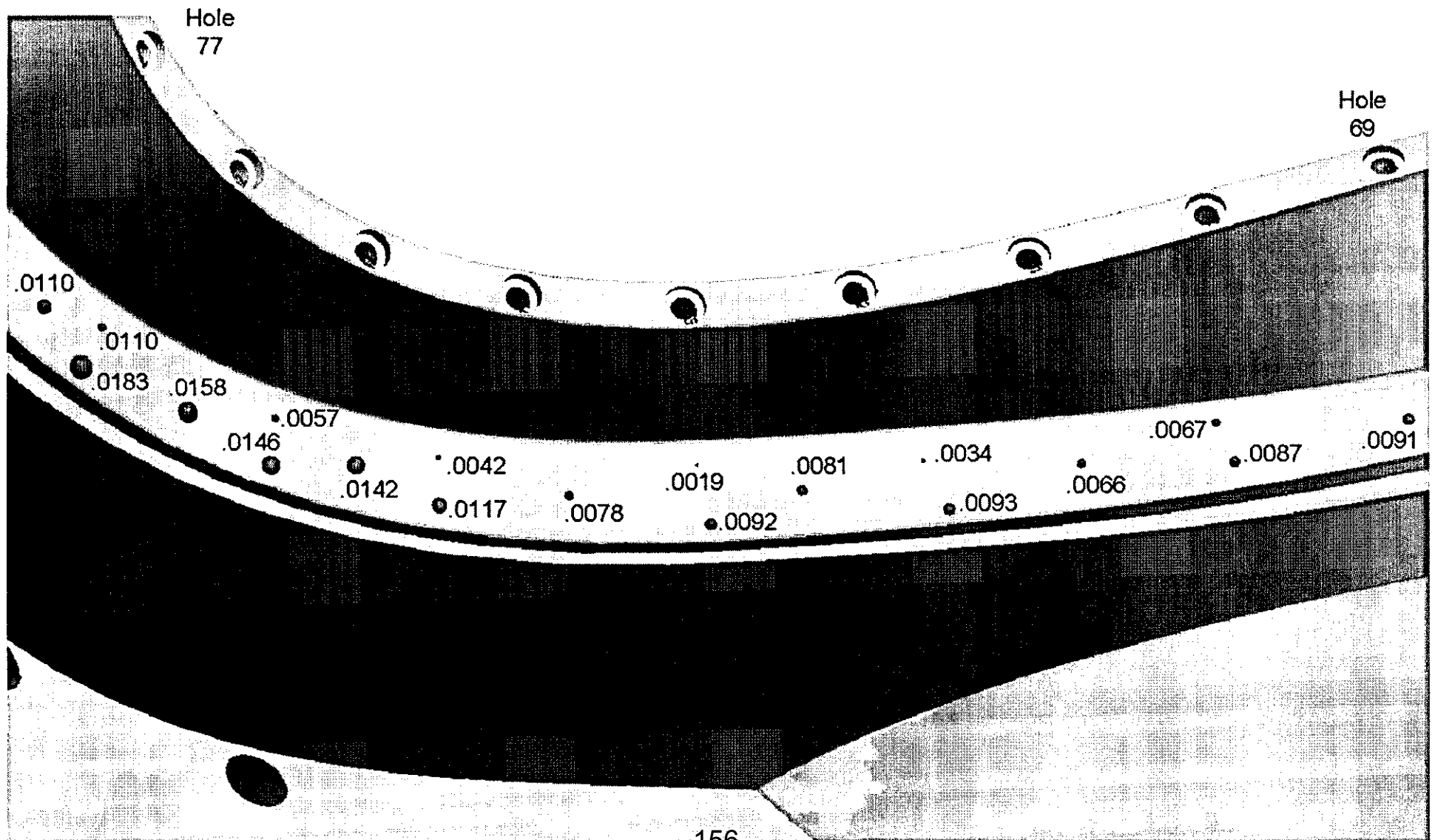

Datum-E tee web between holes 84 and 87

Data indicates C5 high spots beyond +/- .020-in profile tolerance

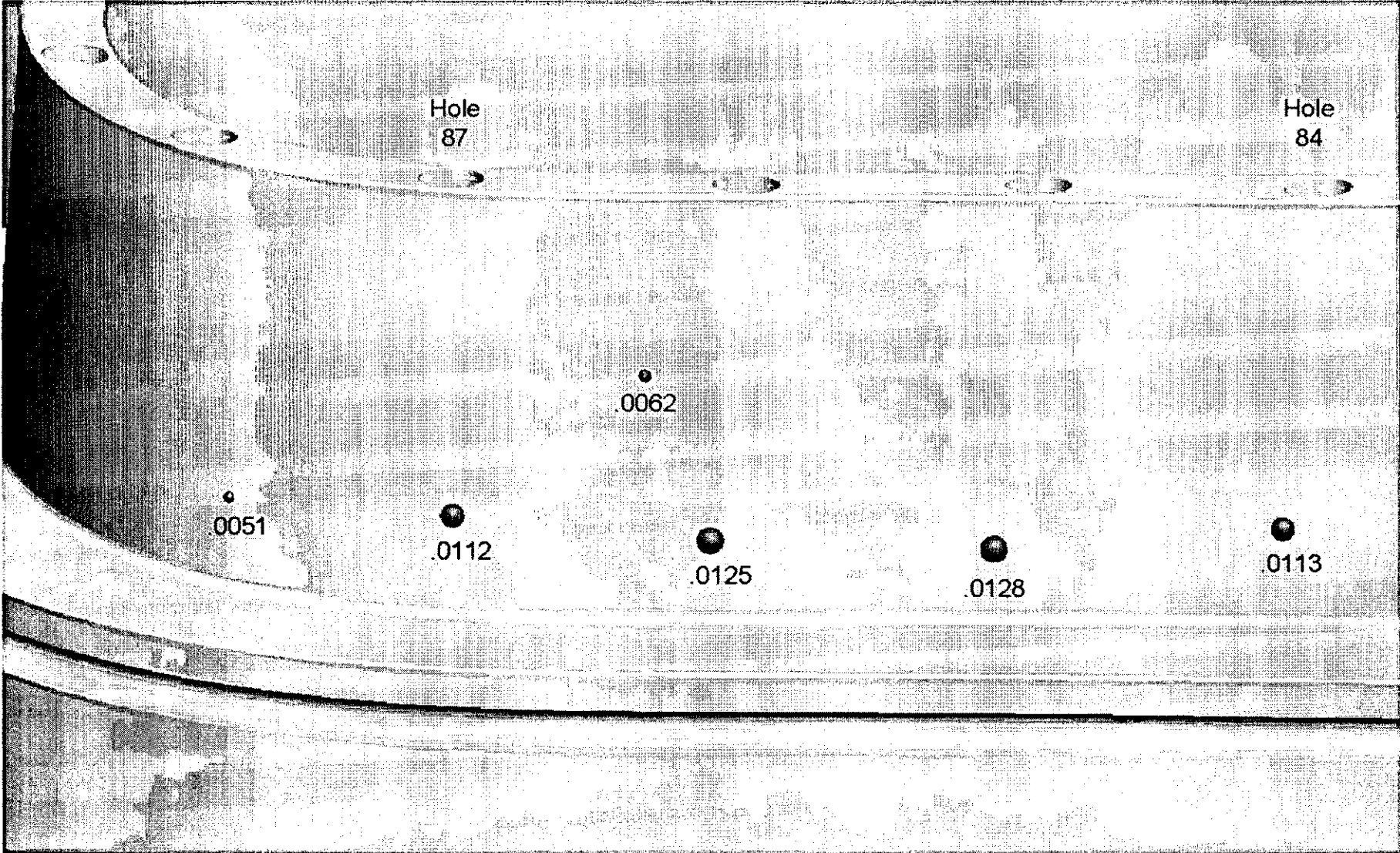

Attachment to NC19713

T section Grinding Summary

Datum -D tee web between holes 65 and 69

Stock to Remove	Before Grind	After Grind	Stock Removed
0.0104	0.774	0.762	0.012
0.0069	0.772	0.764	0.008
0.0061	0.777	0.765	0.012
0.0025	0.762	0.758	0.004
0.0087	0.776	0.762	0.014
0.0037	0.775	0.768	0.007
0.0055	0.774	0.757	0.017
0.0042	0.774	0.758	0.016
0.002	0.774	0.762	0.012
0.0021	0.774	0.766	0.008
0.0042	0.776	0.767	0.009
0.0014	0.773	0.769	0.004
0.0067	0.778	0.767	0.011
0.0056	0.775	0.767	0.008
0.0029	0.773	0.766	0.007
0.0094	0.779	0.765	0.014
0.0069	0.782	0.77	0.012
0.0072	0.773	0.764	0.009
0.0079	0.779	0.764	0.015
0.0023	0.781	0.773	0.008

Datum -D tee base between holes 20 and 23

Stock to Remove	Before Grind	After Grind	Stock Removed
0.0099	4.114	4.129	0.015
0.0035	4.113	4.128	0.015
0.0104	4.111	4.132	0.021
0.0054	4.114	4.125	0.011
0.006	4.12	4.128	0.008
0.0035	4.116	4.128	0.012
0.0033	4.114	4.119	0.005
0.0028	4.122	4.125	0.003
0.0018	4.119	4.121	0.002

Attachment to NC19713
T section Grinding Summary
Datum -E tee base between holes 69 and 77

Stock to Remove	Before Grind	After Grind	Stock Removed
0.011	4.128	4.14	0.012
0.011	4.135	4.147	0.012
0.0183	4.13	4.15	0.02
0.0158	4.129	4.148	0.019
0.0146	4.11	4.128	0.018
0.0057	4.135	4.143	0.008
0.0142	4.129	4.145	0.016
0.0117	4.119	4.134	0.015
0.0042	4.135	4.141	0.006
0.0078	4.134	4.146	0.012
0.0019	4.134	4.138	0.004
0.0092	4.127	4.138	0.011
0.0081	4.133	4.144	0.011
0.0034	4.122	4.128	0.006
0.0093	4.118	4.128	0.01
0.0066	4.115	4.125	0.01
0.0067	4.095	4.102	0.007
0.0087	4.095	4.105	0.01
0.0091	4.13	4.143	0.013

Datum -E tee web between holes 84 and 87

Stock to Remove	Before Grind	After Grind	Stock Removed
0.0051	0.774	0.766	0.008
0.0112	0.779	0.756	0.023
0.0062	0.763	0.751	0.012
0.0125	0.773	0.754	0.019
0.0128	0.772	0.751	0.021
0.0113	0.777	0.758	0.019

Customer: ENERGY INDUSTRIES OF OHIO

Contact: NANCY HORTON
E-Mail: NKHFlowen@aol.com

Telephone: 216-496-2314
Fax: 216-328-2001

Part: SE141-116 / MODULAR COIL WINDING FORM TYPE
Drawing ID: SE141-116-1MTM Revision: 6A

Customer P.O.: S005242-F/Ln:5
Serial No./Qty: C5

Reported By: MIKE GRIFFITH
E-Mail: mGriffith@MajorTool.com

Telephone: 317-636-6433
Fax: 317-634-9420

Problem: THERE ARE MINOR AREAS OF TOOLING NONCLEANUP AND GOUGES ON THE T SECTION AND IN OTHER AREAS AROUND THE CASTING. SEE ATTACHMENT FOR CLARIFICATION.

Proposed Disposition:

Propose to Accept As Is.

Number of additional pages: 1 attachment

Customer Disposition: Use As Is Rework Repair Scrap Replace

The noncleanup and gouges shown in the attachment were reviewed and accepted as is. NCSX will evaluate each of these and may opt to fill those located in winding surface areas with cryogenic grade epoxy filler.

Approved by:

**Phil
Heitzenroeder**

Digitally signed by Phil Heitzenroeder
DN: CN = Phil Heitzenroeder, C = US, O = PPPL, OU = Mech. Eng. Division
Reason: I agree to 'specified' portions of this document
Date: 2006.04.27 14:43:20 -04'00'

**Brad
Nelson**

Digitally signed by Brad Nelson
DN: cn=Brad Nelson, c=US, o=ORNL, ou=FED, email=nelsonbe@ornl.gov
Date: 2006.04.27 17:56:03 -04'00'

Tech. Rep.

RLM

Major Tool Implemented By: _____ Title: _____ Date: _____

SE141-116 C5
NC19718 attachment.

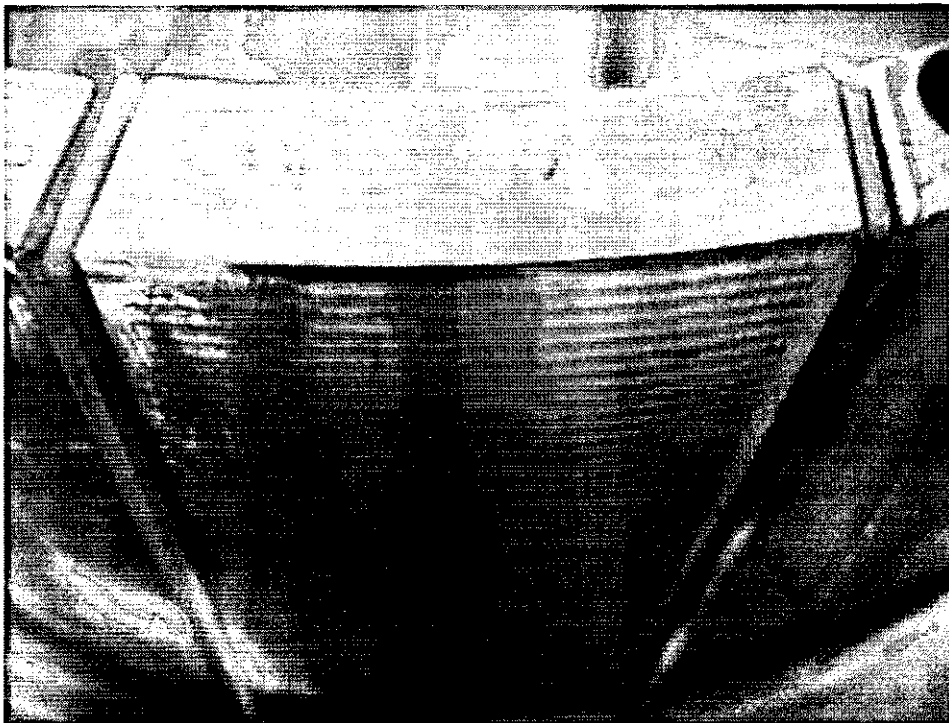

Poloidal Break view – Chamfer on casting (.09”) is larger than chamfer on shim (.06”).



Tool Gouge blended out between pad and lead block slot.

Mike Griffith

Page 1 of 4

4/27/2006



Major
Tool & Machine, Inc.

SE141-116 C5
NC19718 attachment.

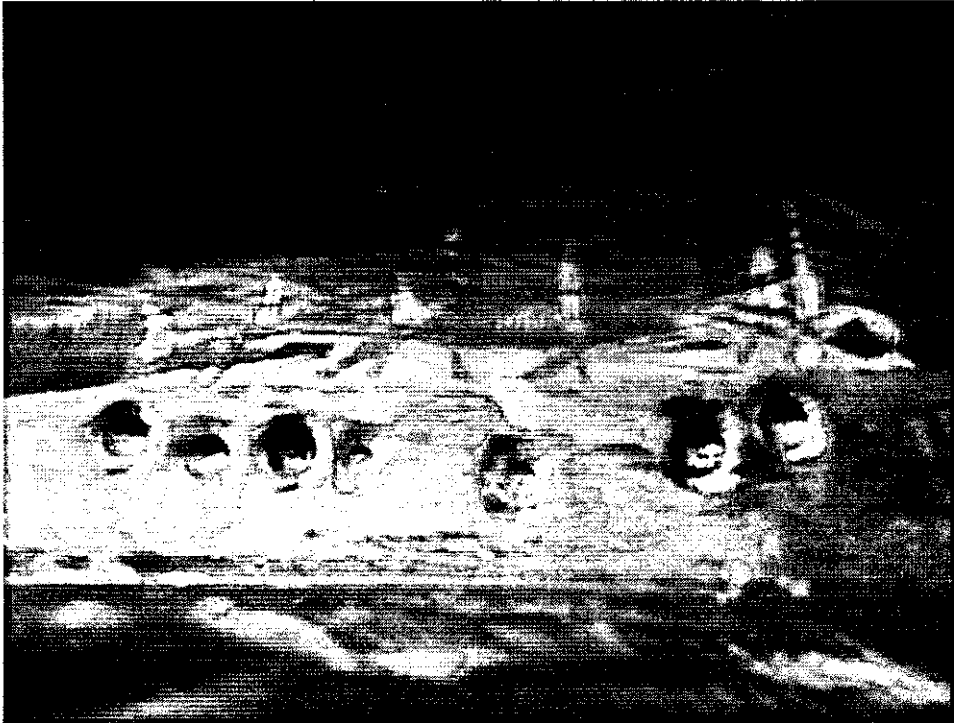

Excavated areas of high permeability beneath VPI groove in radius at casting wall.

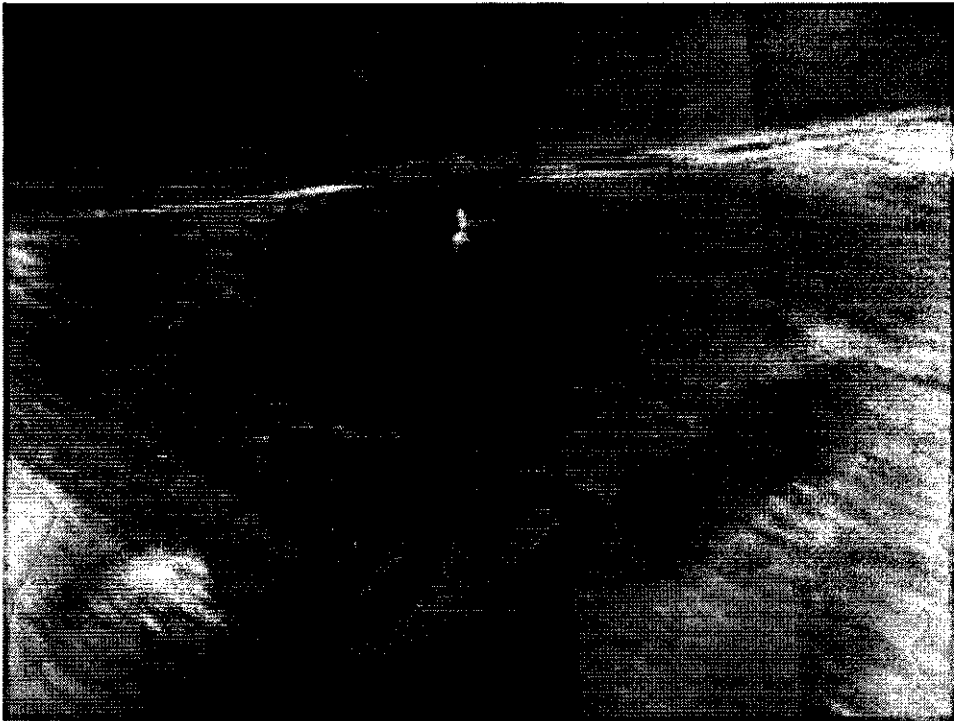

Small cutter noncleanup between long and short legs (.120", .005" deep)

Mike Griffith

Page 2 of 4

4/27/2006



SE141-116 C5
NC19718 attachment.

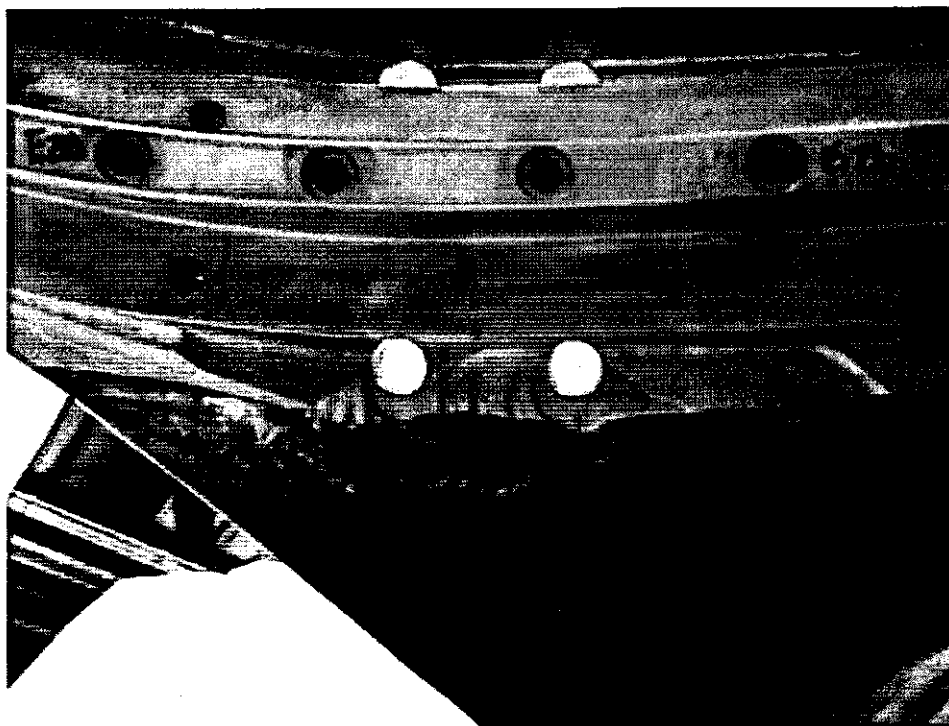

Wide view of cutter noncleaup on short leg between holes 26 and 29 on E side.

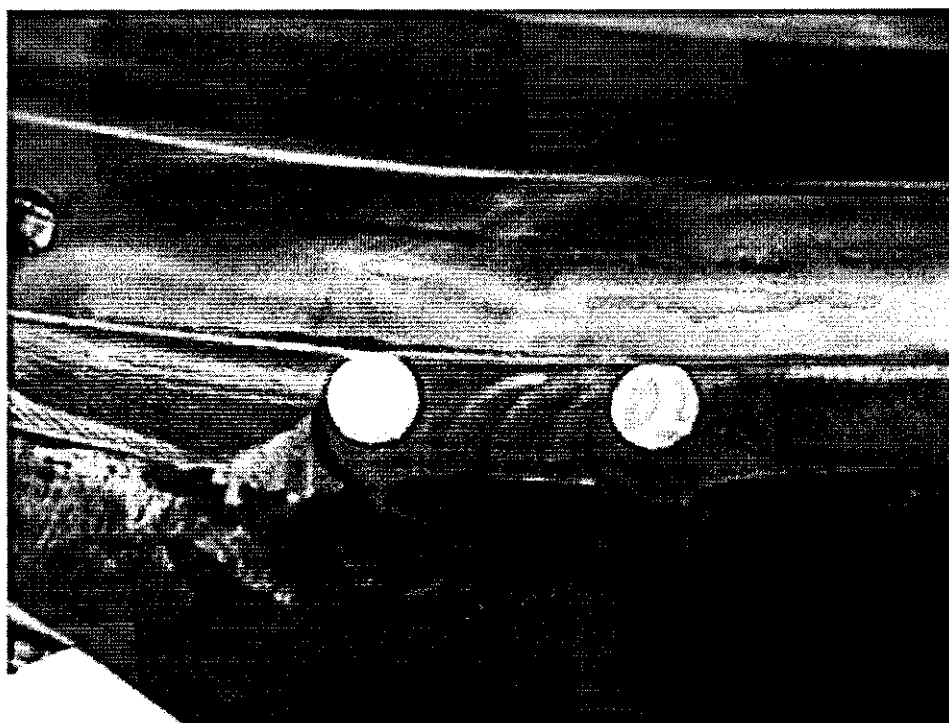

Close up view. Noncleanup is approx. .008" at the max depth and max. of .100" wide.

Mike Griffith

Page 3 of 4

4/27/2006



Major
Tool & Machine, Inc.

SE141-116 C5
NCI9718 attachment.



Area of cutter noncleanup near radius between D33 and D35. Approx. .008" max depth.

Mike Griffith

Page 4 of 4

4/27/2006



EASTWOOD MANUFACTURING
CERTIFICATION OF COMPLIANCE

CUSTOMER: MAJOR TOOL AND MACHINE
ORDER #: P05-01160

DATE: 5-23-05
OUR NUMBER 33388

WE CERTIFY THAT THE MATERIALS SUPPLIED ON YOUR ORDER
LISTED ABOVE COMPLIES WITH THE REQUIREMENTS OF YOUR ORDER
AND OF THE SPECIFICATIONS LISTED BELOW

DESCRIPTION:

Lot No.:	Part:	Heat No.:	
32984-1	DS141-036	8969595	1 7/16 Round, machined to size
98 PIECES	ASTM A286		Heat Treat: 36891
	Silver plated		Silver plate: IMF 00132583
	Per AMS2410		Post plate bake: SEI 38130
			Tensile test: WH 05-0420-01

TENSILE KSI	YIELD KSI	ELONGATION	REDUCTION	HARDNESS
150	120	14	35	
PASS	PASS	PASS	PASS	PASS

DALE STARK
EASTWOOD MANUFACTURING

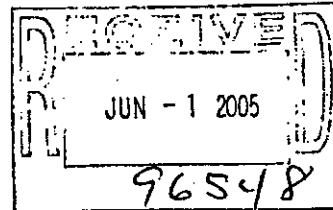

Lines 5-18
B.I.

JUN 01 2005





401 ROSE AVE S E
MASSILLON, OH 44646

FAX 330-837-7017

CERTIFICATE OF TESTS REPUBLIC ENGINEERED PRODUCTS

JANUARY 26, 2005
PAGE: 1 OF 3

PURCHASE ORDER: 42904-3 PURCHASE ORDER DATE: 05/24/04
PART NUMBER : S# 47670 ACCOUNT NUMBER . . . : 27759001
ORDER NUMBER: 12-52585-06 821 SCHEDULE : 58828-
HEAT : 8969595
----- CHARGE ADDRESS ----- SHIP TO -----

58828

FRY STEEL COMPANY
BUNNIE ISAKA
13325 MOLETTE ST
SANTA FE SPRINGS CA 90670

FRY STEEL COMPANY
BUNNIE ISAKA
C/O CMI
4201 W 36TH ST
CHICAGO IL 60623

----- MATERIAL DESCRIPTION -----
COLD FINISHED STEEL BARS ALLOY DOUGLAS SPEC DMS-1555H GRADE B DTD 07/02/91 EKC
MARK & PARA 3.4 OIL TEMP & 3.5 BOEING SPEC BMS 7-28G ASTM A 331-95 ASTM A
108-03 LEVEL 1 MIL S 5000E COND E-4 EKC MARK AMS 6415R EKC BHN AMS 6409B AMS
2310E AMS 2301J AMS 2304A AMS 6484B AMS -S- 5000 ISS 3/99 COND E-4 EKC MARK &
PARA 4.3 EF-AISI-E-4340 AIRCRAFT Q DBL TRANSV MECH PROP COLD DRAWN NOR
M & SUBCRITICAL ANN BEFORE CD REST CHEM

SIZE: RDS 1.4375 X 11 /13FT

LADLE CHEMISTRY %									
C	MN	P	S	SI	CU	NI	CR	MO	AL
0.42	00.75	.007	.002	0.22	0.10	01.70	00.84	0.21	00.028
V	N	CB	SN						
0.005	.0064	0.002	.007						

AUSTENITIC GRAIN SIZE
AUST GRAIN SZ 7.

SEMI-FINISH RESULTS

DEVELOPED TENS TRANS NORMALIZE	ASTM E8 AUSTENITIZE	ASTM A370 QUENCHANT	TEMPER 1
DEG F 1650.	DEG F 1550.	OIL	DEG F 900.
TEMP 1 TIME HOURS 2.0			

	TENSILE PSI	REDUCTION AREA PERCENT
PCE H 10102	185010.	45.5
PCE H 10302	180280.	55.6
PCE T 10503	185540.	55.7
PCE H 30102	180570.	53.4
PCE H 30302	193790.	53.0
PCE T 30504	185240.	46.3

32984

DEVELOPED TENS TRANS NORMALIZE	ASTM E8 AUSTENITIZE	ASTM A370 QUENCHANT	TEMPER 1
DEG F 1650.	DEG F 1500.	OIL	DEG F 475.
TEMPER 2/SR DEG F 475.	TEMP 1. TIME HOURS 2.0	TEMP 2 TIME HOURS 2.0	

	TENSILE PSI	YIELD (.2%) PSI	REDUCTION AREA PERCENT	ELONGATION PERCENT
PCE H 10102	262320.	223800.	47.0	10.4
PCE H 10302	264250.	222910.	44.6	11.4
PCE T 10503	262170.	225100.	44.6	14.3
PCE H 30102	261840.	218860.	43.8	13.4
PCE H 30302	261260.	222160.	49.3	11.4
PCE T 30504	261050.	225230.	48.2	12.9

19111

AMAN BHATIA
GEN MGR COLD FINISH OPERATIONS

Aman Bhatia

JUN 01 2005





401 ROSE AVE S E
MASSILLON, OH 44646

FAX 330-837-7017

CERTIFICATE OF TESTS REPUBLIC ENGINEERED PRODUCTS

JANUARY 26, 2005
PAGE: 2 OF 3

PURCHASE ORDER: 42904-3 PURCHASE ORDER DATE: 05/24/04
PART NUMBER : S# 47670 ACCOUNT NUMBER . . . : 27759001
ORDER NUMBER: 12-52585-06 821 SCHEDULE : 58828-
HEAT : 8969595

SEMI-FINISH RESULTS (CONTINUED)

DEVELOPED TRANS TENSILE		ASTM E8	ASTM A370	TEMPER 1
NORMALIZE		AUSTENITIZE	QUENCHANT	DEG F
DEG F		DEG F	OIL	DEG F
1650.		1500.		475.
TEMPER 2/SR		TEMP 1 TIME	TEMP 2 TIME	
DEG F		HOURS	HOURS	
475.		2.0	2.0	
TENSILE		YIELD (.2%)	REDUCTION AREA	ELONGATION
PSI		PSI	PERCENT	PERCENT
PCE H 10102	256220.	218900.	35.8	9.7
PCE H 10302	260560.	223410.	46.3	10.6
PCE T 10503	254270.	220610.	14.6	7.6
PCE H 30102	263550.	222210.	35.4	11.0
PCE H 30302	261190.	223640.	46.8	12.3
PCE T 30504	258710.	221100.	44.3	11.8

JOMINY STD SAE J406 ASTM A255
1 2 3 4 5 6 7 8 9 10 11 12 13 14 15 16 18 20 22 24 26 28 30 32
58 58 57 57 57 57 56 56 56 56 55 55 55 55 54 53 52 51 51 50 49 49

MACROETCH SRC ASTM E381 MIL STD 430
AVG SURFACE 1. RANDOM 1. CENTER 1.

MAG PARTICLE 2301 AMS 2301
AVG AVG FREQ 0.00 AVG SEV 0.00

MAG PARTICLE 2304 AMS 2304
AVG AVG FREQ 0.00 AVG SEV 0.00

----- FINISH SIZE RESULTS SCHEDULE: 58828
DECARBURIZATION SAE J419 ASTM E1077

PCE 01 TOTAL DEPTH
INCHES
.015

HBW SURFACE (LAB) ASTM E10 ASTM A370
PCE 01 HBW 217.
PCE 02 HBW 217.
PCE 03 HBW 217.
PCE 04 HBW 217.
PCE 05 HBW 223.

MATERIAL SOURCES
RED. RATIO
TO 1
73.6

TENSILE HT TRTD ASTM E8 ASTM A370
NORMALIZE
PCE 01 DEG F
1625.

----- NOTES -----
THE MATERIAL WAS NOT EXPOSED TO MERCURY OR ANY METAL ALLOY THAT IS
LIQUID AT AMBIENT TEMPERATURE DURING PROCESSING OR WHILE IN OUR
POSSESSION.

CHEMICAL ANALYSIS CONFORMS TO APPLICABLE SPECS: ASTM E415, ASTM E1019,
AND ASTM E1085.

32984

AMAN BHATIA
GEN MGR COLD FINISH OPERATIONS
Aman Bhatia

JUN 01 2005





401 ROSE AVE S E
MASSILLON, OH 44646

FAX 330-837-7017

CERTIFICATE OF TESTS REPUBLIC ENGINEERED PRODUCTS

JANUARY 26, 2005
PAGE: 3 OF 3

PURCHASE ORDER: 42904-3	PURCHASE ORDER DATE: 05/24/04
PART NUMBER : SH 47670	ACCOUNT NUMBER . . . : 27759001
ORDER NUMBER: 12-52585-06 821	SCHEDULE : 58828-
HEAT : 8969595	

----- NOTES (CONTINUED) -----
NO WELDING OR WELD REPAIR WAS PERFORMED ON THIS MATERIAL.

RECORDING OF FALSE, FICTITIOUS OR FRAUDULENT STATEMENT OR ENTRIES ON THIS DOCUMENT MAY BE PUNISHED AS A FELONY UNDER FED STATUBS TITLE 18 CHAPTER 47.

I HEREBY CERTIFY THAT THE MATERIAL LISTED HEREIN HAS BEEN INSPECTED AND TESTED IN ACCORDANCE WITH THE METHODS PRESCRIBED IN THE GOVERNING SPECIFICATIONS AND BASED UPON THE RESULTS OF SUCH INSPECTION AND TESTING HAS BEEN APPROVED FOR CONFORMANCE TO THE SPECIFICATIONS.

CERTIFICATE OF TESTS SHALL NOT BE REPRODUCED EXCEPT IN FULL.

WHEN EVALUATED, MACRO ETCHES WERE VISUALLY RATED ON SAMPLES ETCHED USING HYDROCHLORIC ACID AT A TEMPERATURE 170 DEGREES (F) (+/- 10 DEGREES F)

ALL TESTING HAS BEEN PERFORMED USING THE CURRENT REVISION OF THE TESTING SPECIFICATIONS.

MFG IN THE U.S.A.

ALISON J. BLONDHEIM
NOTARY PUBLIC, STATE OF OHIO
MY COMMISSION EXPIRES MARCH 10, 2009

----- END OF DATA -----	CC -----	----- END OF DATA -----
FAX SHIP TO 1 COPY	ATTENTION BUNNIE ISAKA	562-802-7481
MAIL SOLD TO 1 COPY	ATTENTION BUNNIE ISAKA	
FILE 1 COPY		
WITH SHIPMENT 1 COPY		

SHIPPING AREA:

32984

FRY STEEL CO. CERTIFIES THAT THIS IS
A TRUE COPY OF THE ORIGINAL MILL TEST
REPORT NOW ON FILE.
RECEIVED AND INSPECTED

FEB 14 2005

Bunnie Isaka
BUNNIE ISAKA, O.C. MANAGER

JUN 01 2005



AMAN BHATIA
GEN MGR COLD FINISH OPERATIONS

Aman Bhatia

Tensile Test Report

Company: Eastwood Mfg. Date: 4/22/2005
 Attention: Dale Stark Lab Report #: 05-0420-01
 Identification: AISI 4340 P.O. #: 32984
 Procedure: _____ 1-3/8" O.D.
 Process: _____
 Filler: _____ Heat#8969595
 Qualification: _____
 Welder: _____

32984

32984

TENSILE TEST

Lab ID	Dimensions	Area	Yield Lbs	Ultimate Load Lbs	Yield P.S.I.	Tensile P.S.I.
C	.504 round	.1995	31,860	34,700	159,700	174,000

Elongation	Reduction of Area	Fracture	Comments
16.2%	52.3%	Ductile	

Tests performed in accordance with ASTM A370, E8, and WH Laboratories, LLC Quality Assurance Manual.
 2% Offset Yield - Gage Length 2.000" for 350", and 1.400" for 350" tensile per ASTM A370.
 Test specimens retained for one (1) week maximum; unused material is retained for one (1) month.

Approved by: Robert French
 Robert French

JUN 01 2005



SEI HEAT TREAT

PO BOX 16339 HOUSTON, TX 77222
 PHONE (713) 699-3892 FAX (713) 699-7551

CUSTOMER: EASTWOOD MANUFACTURING	CERTIFICATION DATE: May 19, 2005
CERTIFICATION/SO NUMBER: 38130	CUSTOMER ORDER NUMBER: 33388

MATERIAL: N/A	NUMBER OF PIECES: 98
DESCRIPTION: 1-3/8" X 9" STUD SILVER PLATED	PART NUMBER(S): N/A
SPECIFICATION NUMBER: EASTWOOD MANUFACTURING	REFERENCE: N/A

38730,

HEAT TREAT PROCESS	TIME AT HEAT	COOLANT
<i>Bake</i>	<i>950°</i>	<i>1hr</i>
		<i>AIR</i>

HARDNESS TEST:	NUMBER OF PIECES TESTED:

WE HEREBY CERTIFY THAT THE SERVICE FURNISHED ON THE ABOVE PURCHASE ORDER IS PROVIDED IN ACCORDANCE WITH OUR QUALITY CONTROL MANUAL, REVISION B, DATED JANUARY 21, 2001	QUALITY CONTROL: <i>Lucia Flo</i>
---	---

JUN 01 2005



INDUSTRIAL METAL FINISHING

CERTIFICATE OF COMPLIANCE

TO: EASTWOOD MFG. 5/86
P.O. BOX 41447
HOUSTON, TX 77241

THIS IS TO CERTIFY THAT THE METAL FINISHING SERVICE RENDERED ON ITEM(S)

126 EA. - 1.375 X 9 DE STUDS
252 EA. - 2.75 OD WASHERS
252 EA. - 1.375 12PT NUTS

ON PURCHASE ORDER 32984 LISTED ON OUR INVOICE #00132583

MEETS OR EXCEEDS THE REQUIREMENTS OF SPECIFICATION NUMBER

CERT: SILVER PLATE PER AMS 2410
NO BAKE REQUIRED

QUALITY PROGRAM DATED: 05/01/93 REVISION: 1 DATED: 04/01/94

Tair McPherson
NAME:

QC Manager 9/10/05
TITLE DATE

32984

EASTWOOD MANUFACTURING
CERTIFICATION OF COMPLIANCE

CUSTOMER : MAJOR TOOL AND MACHINE
ORDER # : P05-01162

DATE : 5-23-05
OUR NUMBER 33387

WE CERTIFY THAT THE MATERIALS SUPPLIED ON YOUR ORDER
LISTED ABOVE COMPLIES WITH THE REQUIREMENTS OF YOUR ORDER
AND OF THE SPECIFICATIONS LISTED BELOW

DESCRIPTION :

Lot No.:	Part :	Heat No.:	2 3/4 Round, machined to size
32983-1 196 PIECES	DS141-079	8990135	Heat Treat: 36891
	ASTM A286		Silver plate: IMF 00132583
	Silver plated		Post plate bake: SEI 38131
	Per AMS2411		Tensile test: WH 05-0420-01

TENSILE KSI	YIELD KSI	ELONGATION	REDUCTION	HARDNESS
150	120	14	35	
PASS	PASS	PASS	PASS	PASS

DALE STARK
EASTWOOD MANUFACTURING

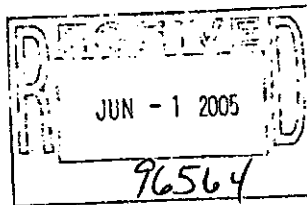

Cons 5-18

BA JUN 01 2005





401 ROSE AVE S E
MASSILLON, OH 44646

FAX 330-837-7017

CERTIFICATE OF TESTS REPUBLIC ENGINEERED PRODUCTS

FEBRUARY 14, 2005
PAGE: 1 OF 3

PURCHASE ORDER: 43004-8 PURCHASE ORDER DATE: 07/13/04
PART NUMBER : S# 48960 ACCOUNT NUMBER : 27759001
ORDER NUMBER: 12-52806-08 821 SCHEDULE : 60703-
HEAT : 8990135
----- CHARGE ADDRESS ----- SHIP TO -----

5610603

FRY STEEL COMPANY
BUNNIE ISAKA
13325 MOLETTE ST
SANTA FE SPRINGS CA 90670

FRY STEEL COMPANY
BUNNIE ISAKA
C/O CMI
4201 W 36TH ST
CHICAGO IL 60623

----- MATERIAL DESCRIPTION -----
COLD FINISHED STEEL BARS ALLOY DOUGLAS SPEC DMS-1555H GRADE B DTD 07/02/91 EXC
MARK & PARA 3.4 OIL TEMP & 3.5 BOEING SPEC BMS 7-28G LTV VUGHT AERO SPEC CVA
1-585G & AMD 1 EXC RED/AREA ASTM A 331-95 ASTM A 108-03 LEVEL 1 MIL S 5000E
COND E-3 EXC MARK AMS 6415R AMS 6409B AMS 2310E AMS 2301J AMS 2304A AMS 6484B
AMS - S - 5000 ISSUE DTD 3/99 COND E3 EXC MARK EF-AISI-E-4340 AIRCR
APT O DBL TRANSV MECH PROP ROUGH TURNED NORM & SUBCRITICAL ANN BEFORE TURN S
STRAIGHT REST CHEM FREE FROM DECARB

SIZE: RDS 2.7500/2.7734 X 11 /13FT
----- LADLE CHEMISTRY % -----
C 0.42 MN 00.73 P 0.007 S 0.004 SI 0.26 CU 0.15 NI 01.74 CR 00.86 MO 0.20 AL 00.034
V N CE SN
0.003 .0057 0.002 .010
----- SEMI-FINISH RESULTS -----

AUSTENITIC GRAIN SIZE
AUST GRAIN SZ 7.

DEVELOPED TENS TRANS NORMALIZE DEG F 1650.	ASTM E8 AUSTENITIZE DEG F 1550.	ASTM A370 QUENCHANT OIL	TEMPER 1 DEG F 900.
TEMP 1 TIME HOURS 2.0			

	TENSILE PSI	REDUCTION AREA PERCENT
PCE H 20102	187750.	42.6
PCE H 20302	190780.	50.8
PCE T 20503	189630.	49.5
PCE H 40102	190530.	49.0
PCE H 40302	190020.	48.4
PCE T 40503	187050.	51.2

DEVELOPED TRANS TENSILE NORMALIZE DEG F 1650.	ASTM E8 AUSTENITIZE DEG F 1500.	ASTM A370 QUENCHANT OIL	TEMPER 1 DEG F 475.
TEMPER 2/SR DEG F 475.	TEMP 1 TIME HOURS 2.0	TEMP 2 TIME HOURS 2.0	

	TENSILE PSI	YIELD (.2%) PSI	REDUCTION AREA PERCENT	ELONGATION PERCENT
PCE H 20102	269150.	229500.	33.4	8.7
PCE H 20302	265160.	228430.	36.0	11.6
PCE T 20503	264570.	227270.	39.0	10.6
PCE H 40102	267580.	228000.	39.0	9.6
PCE H 40302	268390.	228870.	42.0	11.4
PCE T 40503	266130.	220000.	40.3	13.0

2146

32984

AMAN BHATIA
GEN MGR COLD FINISH OPERATIONS

Amman Bhatia

JUN 01 2005





401 ROSE AVE S E
MASSILLON, OH 44646

FAX 330-837-7017

CERTIFICATE OF TESTS

REPUBLIC ENGINEERED PRODUCTS

FEBRUARY 14, 2005
PAGE: 2 OF 3

PURCHASE ORDER: 43004-8
PART NUMBER : S# 48960
ORDER NUMBER: 12-52806-08 821
HEAT : : 8990135
PURCHASE ORDER DATE: 07/13/04
ACCOUNT NUMBER : : 27759001
SCHEDULE : : 60703-

SEMI-FINISH RESULTS (CONTINUED)

DEVELOPED TRANS TENSILE	ASTM E8	ASTM A370	TEMPER 1
NORMALIZE	AUSTENITIZE	QUENCHANT	DEG F
DEG F	DEG F	OIL	475.
1650.	1500.		
TEMPER 2/SR	TEMP 1 TIME	TEMP 2 TIME	
DEG F	HOURS	HOURS	
475.	2.0	2.0	
TENSILE	YIELD (.2%)	REDUCTION AREA	ELONGATION
PSI	PSI	PERCENT	PERCENT
PCE H 20102 263440.	226720.	23.3	9.3
PCE H 20302 262050.	225300.	10.9	6.3
PCE T 20503 263070.	223390.	37.1	10.0
PCE H 40102 261610.	225430.	10.9	3.0
PCE H 40302 260030.	225620.	33.3	10.6
PCE T 40503 262820.	230000.	36.0	11.5

JOMINY STD	SAE J406	ASTM A255
1 2 3 4 5 6 7 8 9 10 11 12 13 14 15 16 18 20 22 24 26 28 30 32	57 57 56 56 56 56 56 56 55 55 54 54 53 52 52	
59 59 58 58 58 57 57 57 57 57 57 57 57 57 57 56 56 56 55 55 54 54 53 52 52		

MACROETCH SRC SURFACE 1. RANDOM 1. CENTER 1.
AVG

MAG PARTICLE 2301 AMS 2301
AVG AVG FREQ 0.00 AVG SEV 0.00

MAG PARTICLE 2304 AMS 2304
AVG AVG FREQ 0.00 AVG SEV 0.00

FINISH SIZE RESULTS SCHEDULE: 60703

HBW HT TRTD (LAB)	ASTM E10	ASTM A370
PCE 01 SURFACE 197.		
PCE 02 SURFACE 192.		
PCE 03 SURFACE 192.		
PCE 04 SURFACE 192.		
PCE 05 SURFACE 197.		

MATERIAL SOURCES
RED. RATIO
TO 1
20.9

TENSILE HT TRTD ASTM E8 ASTM A370
NORMALIZE
DEG F
PCE 01 1625.

NOTES
DECARB NIL

THE MATERIAL WAS NOT EXPOSED TO MERCURY OR ANY METAL ALLOY THAT IS LIQUID AT AMBIENT TEMPERATURE DURING PROCESSING OR WHILE IN OUR POSSESSION.

CHEMICAL ANALYSIS CONFORMS TO APPLICABLE SPECS: ASTM E415, ASTM E1019, AND ASTM E1085.

NO WELDING OR WELD REPAIR WAS PERFORMED ON THIS MATERIAL.

RECORDING OF FALSE, FICTITIOUS OR FRAUDULENT STATEMENT OR ENTRIES ON THIS DOCUMENT MAY BE PUNISHED AS A FELONY UNDER FED STATUES TITLE 18 CHAPTER 47.

AMAN BHATIA
GEN MGR COLD FINISH OPERATIONS

Amn Bhatia

JUN 01 2005



32984



401 ROSE AVE S E
MASSILLON, OH 44646

FAX 330-837-7017

CERTIFICATE OF TESTS REPUBLIC ENGINEERED PRODUCTS

FEBRUARY 14, 2005
PAGE: 3 OF 3

PURCHASE ORDER: 43004-8
PART NUMBER : S# 48960
ORDER NUMBER: 12-52806-08 821
HEAT : 8990135

PURCHASE ORDER DATE: 07/13/04
ACCOUNT NUMBER . . . : 27759001
SCHEDULE : 60703-

NOTES (CONTINUED)

I HEREBY CERTIFY THAT THE MATERIAL LISTED HEREIN HAS BEEN INSPECTED AND TESTED IN ACCORDANCE WITH THE METHODS PRESCRIBED IN THE GOVERNING SPECIFICATIONS AND BASED UPON THE RESULTS OF SUCH INSPECTION AND TESTING HAS BEEN APPROVED FOR CONFORMANCE TO THE SPECIFICATIONS.

CERTIFICATE OF TESTS SHALL NOT BE REPRODUCED EXCEPT IN FULL.

WHEN EVALUATED, MACRO ETCHES WERE VISUALLY RATED ON SAMPLES ETCHED USING HYDROCHLORIC ACID AT A TEMPERATURE 170 DEGREES (F) (+/- 10 DEGREES F)

ALL TESTING HAS BEEN PERFORMED USING THE CURRENT REVISION OF THE TESTING SPECIFICATIONS.

MFG IN THE U.S.A.

ALISON J. BLONDHEIM
NOTARY PUBLIC, STATE OF OHIO
MY COMMISSION EXPIRES MARCH 10, 2009

----- END OF DATA ----- CC ----- END OF DATA -----
FAX SHIP TO 1 COPY ATTENTION BUNNIE ISAKA 562-802-7481
MAIL SOLD TO 1 COPY ATTENTION BUNNIE ISAKA
FILE 1 COPY
WITH SHIPMENT 1 COPY

SHIPPING AREA:

22984

FRY STEEL CO. CERTIFIES THAT THIS IS
A TRUE COPY OF THE ORIGINAL MILL TEST
REPORT NOW ON FILE.
RECEIVED AND INSPECTED

FEB 21 2005

Bunnie Isaka
BUNNIE ISAKA - MGR. OPERATIONS

JUN 01 2005



AMAN BHATIA
GEN MGR. COLD FINISH OPERATIONS

Aman Bhatia

Es wood Manufacturing
 5825 Breen Rd.
 Houston, Texas 77086
 (281) 4-0081 fax (281) 447-0098

P05-01161

INSPECTION DATA
 CHECK LIST
 FOR
 Major Tool & Machine Inc.

Part Number (Detail / Sub-Assy / Assy) DS141-060	Rev.	Page of 1 1
Part Name (Detail / Sub-Assy / Assy) Nut, 12 pt 1.375-6 UNC-2B		
MATERIAL:	WORK ORDER # 32982	Quantity 252

P.O.	DRAWING - SPECIFICATION DESCRIPTION		INSPECTION INSTRUCTIONS			INSPECTION RESULTS DATA, CAR NO, REMARKS	INSPECTED BY			
	SHT	REV	CHARACTERISTIC	GAGE/EQUIP.	BY		SAMPLE	MFG	QA	DATE
			1.375 Maximum	Caliper #200	ns	25	1.375 - 1.370		NS	5-5-05
			2.216 Maximum	Caliper #200	ns	25	2.210 - 2.205		NS	5-5-05
			1.00	Caliper #200	ns	25	1.010 - 1.000		NS	5-5-05
			1.225 Minor Dia. 1.195	Caliper #200	ns	25	1.210 - 1.205		NS	5-5-05
			Thread GO - NOGO	gage 243 244	ns	25	ok		NS	5-5-05
			Across Flat 1.62	Caliper #200	ns	25	1.62		NS	5-5-05

COMMENT: RECORD ALL DIMENSIONS THAT CARRIES A TOLERANCE OF (+-) .25mm OR LESS

WTA 09 JUN 01 2005

mc108531.tif (1678x2118x2 tif) [5]

Tensile Test Report

Company: Eastwood Mfg. Date: 4/27/2005
 Attention: Dale Stark Lab Report #: 05-0428-20
 Identification: AISI 4140 P.O. #: 32082
 Procedure: 1-5/8" Diameter Bar
 Process: _____
 Filler: _____
 Qualification: _____
 Welder: _____

TENSILE TEST

Lab ID	Dimensions	Area	Yield Lbs	Ultimate Load Lbs	Yield P.S.I.	Tensile P.S.I.
E	.252 round	.0499	7,140	8,000	143,100	160,400

Elongation	Reduction of Area	Fracture	Comments
18.9%	61.2%	Ductile	

Tests performed in accordance with ASTM A370, E8, and WH Laboratories, LLC Quality Assurance Manual
 2% Offset Yield - Gage Length 2.000" for .500", and 1.400" for .360" tensile per ASTM A370.
 Test specimens retained for one (1) week maximum; unused material is retained for one (1) month.

Approved by: Robert French
 Robert French

MUN 01 2005



SEI HEAT TREAT

PO BOX 16339 HOUSTON, TX 77229
 PHONE (713) 699-3892 FAX (713) 699-3893

~~38131~~ 33387

CUSTOMER: EASTWOOD MANUFACTURING	CERTIFICATION DATE: May 19, 2005
CERTIFICATION/SO NUMBER: 38131	CUSTOMER ORDER NUMBER: 33387

MATERIAL: N/A	NUMBER OF PIECES: 98
DESCRIPTION: 2-3/4" WASHERS SILVER PLATED	PART NUMBER(S): N/A
SPECIFICATION NUMBER: EASTWOOD MANUFACTURING	REFERENCE: N/A

HEAT TREAT PROCESS	TIME AT HEAT	COOLANT
<i>BAKE</i>	<i>900°</i>	<i>40 min</i>
		<i>AIR</i>

~~38131~~ 33387

HARDNESS TEST:	NUMBER OF PIECES TESTED:

WE HEREBY CERTIFY THAT THE SERVICE FURNISHED ON THE ABOVE PURCHASE ORDER IS PROVIDED IN ACCORDANCE WITH OUR QUALITY CONTROL MANUAL, REVISION B, DATED JANUARY 21, 2001	QUALITY CONTROL: <i>Jami [Signature]</i>
---	--

JUN 01 2005





INDUSTRIAL METAL FINISHING

CERTIFICATE OF COMPLIANCE

TO: EASTWOOD MFG. 5/86
P.O. BOX 41447
HOUSTON, TX 77241

THIS IS TO CERTIFY THAT THE METAL FINISHING SERVICE RENDERED ON ITEM(S)

126 EA. - 1.375 X 9 DE STUDS
252 EA. - 2.75 OD WASHERS
252 EA. - 1.375 12PT NUTS

ON PURCHASE ORDER 32984 LISTED ON OUR INVOICE #00132583

MEETS OR EXCEEDS THE REQUIREMENTS OF SPECIFICATION NUMBER

CERT: SILVER PLATE PER AMS 2410
NO BAKE REQUIRED

QUALITY PROGRAM DATED: 05/01/93 REVISION: 1 DATED: 04/01/94

Tara McElroy
NAME:

QC Manager *7/10/05*
TITLE DATE

32984

JUN 01 2005



MAJOR TOOL & MACHINE INC 1458 E 19TH ST INDIANAPOLIS IN 46218	YOUR PURCHASE ORDER NUMBER P05-01260 Today's Date:	MCMASTER-CARR 400 COUNTY LINE ROAD ELMHURST IL 60126-2001 IF THERE ARE ANY QUESTIONS ABOUT THIS SHIPMENT CONTACT OUR SALES DEPARTMENT (630)833-0300	PAGE 1 MCM NUMBER 6148181-02
--	---	---	---

Warehouse Location	McMaster Carr Part Number	FR Quantity	Item Description	Your Line	Your Order	This Shipment
PACKING LIST EXTRA	74765 A86	1 EA	LOCTITE PRISM SUPER BLUE TOUGHENED, NUMBER 411, 1-POUND BOTTLE, CLEAR	3	1 EA	1
	74765 A86	1 EA	LOCTITE PRISM SUPER BLUE TOUGHENED, NUMBER 411, 1-POUND BOTTLE, CLEAR	4	1 EA	1
	74765 A86	1 EA	LOCTITE PRISM SUPER BLUE TOUGHENED, NUMBER 411, 1-POUND BOTTLE, CLEAR	5	1 EA	1
	74765 A86	1 EA	LOCTITE PRISM SUPER BLUE TOUGHENED, NUMBER 411, 1-POUND BOTTLE, CLEAR	6	1 EA	1

3/9/05
 94076
 Lines 3-6
 B.J.

LTR 08
 3/9/05

REFER TO: 6148181-02
 MAJOR TOOL & MACHINE INC

TAG
CCP

PAPER	NUMBER OF CARTONS	FILLER	LNS: 4
-------	-------------------	--------	--------

CYCLE

CERTIFICATION OF COMPLIANCE

This is to certify that, according to our records, the above item(s) furnished on your purchase order was supplied in accordance with the description and as illustrated in our catalog.

Sincerely,

B. Hedstrom
 Brian Hedstrom
 Quality Manager

MCM NO. 6148181-02 04

PURCHASE ORDER
 P05-01260

FROM:
 MCMASTER-CARR
 400 COUNTY LINE ROAD
 ELMHURST IL 60126-2001 USA

SHIP TO:

MAJOR TOOL & MACHINE INC
 1458 E 19TH ST
 INDIANAPOLIS IN 46218

CCP



55 Nadeau Drive
 Rochester, NH 03867
 Ph: (603) 332-6555 Fax: (603) 332-5357
 www.spauldingcom.com

Shipping List 072435
 Customer No 101193
 Sales Order Shipper

Sold to : STANDARD GRINDING & MFG CO
 3721 W. CHASE AVENUE
 SKOKIE, IL 60076
 United States

Ship to : STANDARD GRINDING & MFG CO
 3721 W. CHASE AVENUE
 SKOKIE, IL 60076
 United States

Ship Date	Customer PO	Sales Order	# of Boxes	Weight	Ship Via	Bill of Lading	FOB
05/17/2005	80624	065171-00	1	0	YELLOW	072435	DE
Item	Part / Description / Details				Order Quantity	Ship Qty	
000001	39GTCNY7312SANMWF UMSHT SO Item #				1.00000		
	G-11 CR 48" untrimmed X 36" untrimmed Thickness: 3.125" +/- .110" PLEASE NOTE THAT THERE IS NO NEMA STANDARD FOR G-11 CR SHEET SPAULDING C OF C TO G-11 CR SHEET NO TESTING REQUIRED AT TIME OF ORDER <i>Sheet Lead 3.55076</i>					1.00000	
 By: <i>[Signature]</i>					 96507 Lines 1, 2 B.I. MTH 05 5/31/05		

CERTIFICATE of CONFORMANCE

WE HEREBY CERTIFY THAT THE MATERIAL SUPPLIED ON THIS ORDER WAS MADE IN ACCORDANCE WITH THE STANDARDS AND PROCESSES ESTABLISHED BY SPAULDING COMPOSITES COMPANY FOR THE REQUIREMENTS OF MATERIAL DESCRIBED ABOVE.

LOT # _____ DOM _____
 Authorized By: Mark L. Canillo Date: 05/17/2005

Customer Copy

Page # 1

Form: SCSHIP Rev: 8/99

02/002/003

ATLAS FIBRE CO.

847 674 1723

05/26/05 13:00



55 Nadeau Drive
 Rochester, NH 03867
 Ph: (603) 332-9555 Fax: (603) 332-5397
 www.spauldingcom.com

Shipping List 072434
 Customer No 101193
 Sales Order Shipper

Sold to : STANDARD GRINDING & MFG CO
 3721 W. CHASE AVENUE
 SKOKIE, IL 60076
 United States

Ship to : STANDARD GRINDING & MFG CO
 3721 W. CHASE AVENUE
 SKOKIE, IL 60076
 United States

Ship Date	Customer PO	Sales Order	# of Boxes	Weight	Shp VIA	Bill of Lading	FOB
05/17/2005	60624	063189-00	1	716	YELLOW	072434	DE
Item	Part / Description / Details					Order Quantity	Ship Qty
000001	39G1CNT71850NMWLF U/M SHT SO Item 5					1.00000	
	G-11-CR 48" UNTRIMMED X 36" UNTRIMMED THK: 1.850" +/- .070" PLEASE NOTE THAT THERE IS NO NEMA STANDARD FOR G-11 CR SHEET SPAULDING C OF C TO G-11 CR SHEET NO TESTING REQUIRED AT TIME OF ORDER						1.00000

RECEIVED
 MAY 19 2005
 By: *[Signature]*

5/31/05

CERTIFICATE of CONFORMANCE

WE HEREBY CERTIFY THAT THE MATERIAL SUPPLIED ON THIS ORDER WAS MADE IN ACCORDANCE WITH THE STANDARDS AND PROCESSES ESTABLISHED BY SPAULDING COMPOSITES COMPANY FOR THE REQUIREMENTS OF MATERIAL DESCRIBED ABOVE.

LOT # _____ DOM.
 Authorized By: Mark A. Caudillo Date: 05/17/2005

INSPECTION DATA CHECKLIST

Quality Assurance Documentation for Part ID: SE141-103 - Item: 15

Workorder: 65707/5-0 Sub:1 Op:140

Part: SE141-103 - MODULAR COIL WINDING FORM TYPE-C - PRODUCTION MODULAR COIL WINDING FORM TYPE-C

Drawing ID: SE141-103 Rev: 3		INSPECTION INSTRUCTIONS			RESULTS		INSPECTED BY				
SHEET	ZONE	CHARACTERISTIC	GAGE/EQUIP	BY	SAMPLE	SER#	DATA/REMARKS	INSP	VERFD	AUDIT	
*		<u>T E S T 1</u> RESISTANCE TO BE >500 kohms CHECK RESISTANCE BETWEEN THE MID-PLANE POLOIDAL BREAK SHIM AND THE WINDING FORM.	MULTIMETER	QA		J-1358	110 MEG-OHMS	840-G.M			A
(10)								04-17-06			
*		<u>T E S T 2</u> RESISTANCE TO BE >500 kohms CHECK RESISTANCE BETWEEN THE JUMPERED BOLTS AND JUMPERED MID-PLANE CASTING AND WINDING FORM.	MULTIMETER	QA		J-1358	110 MEG-OHMS	840-G.M			A
(20)								04-17-06			

METRODE PRODUCTS LTD
 HANWORTH LANE
 CHERTSEY SURREY
 ENGLAND KT16 9LL
 Tel: +44 (0)1932 566721
 Fax: +44 (0)1932 565168
 Email: info@metrode.com
 Internet: http://www.metrode.com



TEST CERTIFICATE
 THIS PRODUCT HAS BEEN MANUFACTURED
 AND SUPPLIED THROUGH A SYSTEM APPROVED
 TO ISO 9001 & 2 OR EQUIVALENT



TEST CERTIFICATE NUMBER 194277

INVOICE TO
EUROWELD LTD 255 ROLLING HILLS ROAD MOORESVILLE NC 28117 USA

DESPATCHED TO
EUROWELD LTD 255 ROLLING HILLS ROAD MOORESVILLE NC 28117 USA

BATCH No.	W020102
OUR ORDER REF.	S01700013 / 1
DATE	09/03/05
PRODUCT	ER9316MNNF TIG 2.4MM
FORM	TIG WIRE
SPECIFICATION	BS EN 12072:2000 W 20 16 3 Mn L

IMPORTANT: Any liability arising from either reliance on this certificate, or use of our products, is strictly limited and governed by our conditions of business.

CUSTOMER ORDER No.
N. 05-39

DELIVERY NOTE DOCUMENT No.
DN0106163

QUANTITY (Kg)
17.5000

CHEMICAL ANALYSIS (WEIGHT %)				CERTIFIED MATERIAL TEST REPORT: BS EN 10204: 3.1.B														
C	Mn	Si	S	P	Cr	Ni	Mo	N	Cu									
0.015	7.43	0.42	0.006	0.014	19.9	15.4	2.62	0.14	0.20									

TYPICAL ALL-WELD METAL MECH. PROPERTIES, AS WELDED:-
 TS: >600 N/mm²; 0.2%PS: >400 N/mm²; EL. ON 4D: 40 %;
 CVN @ -196 DEG.C: 70 J.

3/23/05
 44534
 Live 1
 B-2

Metrode Products Ltd. certifies that the above material conforms to the indicated specifications

B. KYIET
 QA MANAGER

NOTES: *No. includes incidental Co unless otherwise specified
 **No. (Cr) includes incidental Ti unless otherwise specified
 Ferrite is given as FN (Ferrite Number) and measured on all-weld pad using instrument calibrated against NBS related secondary standards (See AWS A4 2-87) unless otherwise specified

All Test certificates issued by METRODE will contain this enclosed seal
 Any receipt of a copy of METRODE Test Certificate without the seal should ensure from the supplier that it is a true and accurate reproduction of the original

mc106579.tif (1652x2103x2.tif)

METRODE PRODUCTS LIMITED
HANWORTH LANE, CHERTSEY

SURREY, UK, KT16 9LL

Tel: +44 (0) 1832 586721

Fax: +44 (0) 1832 585188

Email: info@metrode.com

Website: www.metrode.com

CERTIFIED MATERIAL TEST REPORT

THIS PRODUCT HAS BEEN MANUFACTURED
AND SUPPLIED THROUGH A SYSTEM
APPROVED TO ISO 9001 & 2 OR EQUIVALENT



TEST CERTIFICATE NUMBER

183695

INVOICE TO
EUROWELD LTD
255 ROLLING HILLS ROAD
MOORESVILLE
NC 28117
USA

DESPATCHED TO
EUROWELD LTD
255 ROLLING HILLS ROAD
MOORESVILLE
NC 28117
USA

CUSTOMER ORDER NUMBER	N.05-34
DELIVERY NOTE DOCUMENT NUMBER	DN0105859
QUANTITY (KG)	15.0000
OUR ORDER REFERENCE	SO1787730 / 1
DATE	02/03/05

METRODE WELDING CONSUMABLE	ER316MNNF TIG 2.4mm
FORM	TIG WIRE
BATCH NUMBER	W020132
SPECIFICATION	BS EN 12072:2000 W 20 16 3 Mn L

Chemical Analysis (Weight %)											Type: BS EN 10204: 3.1.B / ASME SFA-5.01: Sch. H	
C	Mn	Si	S	P	Cr	Ni	Mo	N	Cu			
0.015	7.43	0.42	0.008	0.014	19.9	15.4	2.62	0.14	0.20			

--	--	--	--	--	--	--	--	--	--	--	--

Mechanical Tests

Tensile Tests						Impact Energies		
Condition	Test Temperature	R _{p0.2} (MPa)	R _m (MPa)	A4 (%)	Z (%)	Temperature (°C)	Impact Energy (J)	Lateral Expansion (mm)
AS-WELDED	ROOM	>400	>600	40	-	-196	70	-

Metrode Products Limited certifies that the above material conforms to the indicated specifications.

This document is produced electronically and is valid without signature.

IMPORTANT: Any liability arising from other reliance on this certificate, or use of our products, is strictly limited and governed by our conditions of business.

Berrie Kyte - Q.A. Manager

ASME SFA-5.01; Lot classification: 54

3/3/05
93911
Line 1 B.1

Notes:
% In inclusive instead of Ex unless otherwise specified.
% In (Ch) inclusive instead of % unless otherwise specified.
Parts is given as Pd (Part number) and measured on standard part using instrument calibrated against a gain MRS-related secondary standards (see ISO 9001:2000) unless otherwise specified.

3/3/05
93911
Line 1 B.1

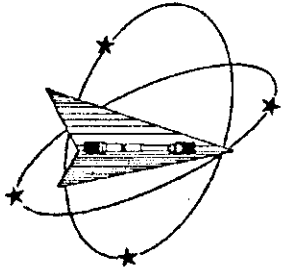

Westmoreland Mechanical Testing & Research, Inc.

P.O. Box 388

Westmoreland Drive

Youngstown, Pa. 15696-0388 U.S.A.

Telephone: 724-537-3131 Fax: 724-537-3151

Website: www.wmtr.com

WMT&R is a technical leader in the material testing industry.



621-01 & 621-02



April 22, 2005

CERTIFICATION

Page IM1 of 1

Major Tool & Machine Inc.
1458 East 19th Street
Indianapolis, IN 46218

Corrected Date
May 4, 2005

WMT&R Report No. 5-25008
P.O. No. P05-01764
PQR No. 434
Welder Jason Bever #465

Attention: Josh Mayne

Subject: All processes, performed upon the material as received, were conducted at WMT&R, Inc. in accordance with the WMT&R Quality Assurance Manual, Rev. 9, dated 4/1/2000.
The following tests were performed on this order: IMPACT and TENSILE

IMPACT RESULTS: ASME Section IX and AWS B2.1, ASTM E23-02

No Requirements

MATERIAL: Metaltek CF8MNMN MOD

SAMPLE TYPE: Charpy V-Notch

DISPOSITION: Report

Specimen ID	TestLog Number	Sample Size	Temp. °F/°C	Energy ft-lbs	Energy joules	Mils Lat Exp	AIUR
Weld-1	B65835	Standard	68/20	173	234.6	84	Report
Weld-2	B65836	Standard	68/20	160	216.9	68	Report
Weld-3	B65837	Standard	68/20	157	212.9	81	Report

AIUR: A=ACCEPTABLE, U=UNACCEPTABLE, R=REPORT

KNOWINGLY OR WILFULLY FALSIFYING OR CONCEALING A MATERIAL FACT ON THIS FORM OR MAKING FALSE, FICTITIOUS OR FRAUDULENT STATEMENTS OR REPRESENTATIONS HEREIN COULD CONSTITUTE A FELONY PUNISHABLE UNDER FEDERAL STATUTES THIS CERTIFICATE OR REPORT SHALL NOT BE REPRODUCED EXCEPT IN FULL, WITHOUT THE WRITTEN APPROVAL OF WMT&R, INC.

Richard G. Parks
Project Manager/Industrial Technology Engineer

5/4/05
May 4, 2005

Testing Specialists for Aerospace, Automotive, and Material Testing Fields
Locations in Youngstown, PA U.S.A. ~ Tel. (724) 537-3131 and
Banbury U.K. ~ Tel. +44 (0) 1295 261211

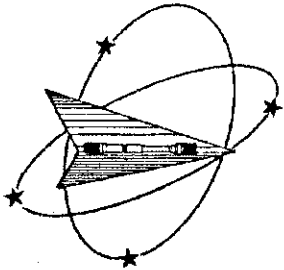

Westmoreland Mechanical Testing & Research, Inc.

P.O. Box 388

Westmoreland Drive

Youngstown, Pa. 15696-0388 U.S.A.

Telephone: 724-537-3131 Fax: 724-537-3151

Website: www.wmtr.com

WMT&R is a technical leader in the material testing industry.



621-01 & 621-02



Section 1 of 2

WMT&R Report No. 5-25008

P.O. No. P05-01764

PQR No. 434

Welder Jason Bever #465

April 20, 2005

Major Tool & Machine Inc.
1458 East 19th Street
Indianapolis, IN 46218

Attention: Josh Mayne

Subject: All processes, performed upon the material as received, were conducted at WMT&R, Inc. in accordance with the WMT&R Quality Assurance Manual, Rev. 9, dated 4/1/2000.
The following tests were performed on this order: IMPACT and TENSILE

TENSILE RESULTS: ASME Section IX and AWS B2.1, ASTM E21-03a

SOAK TIME: 5 Minutes

SPEED OF TESTING: 0.0050 in./in./min., 0.0500 in./min./in.

MATERIAL: Metrode ER316Mnnf

DISPOSITION: Report

Specimen ID	TestLog Number	Temp. °F/°C	UTS KSI/MPA	0.2% YS KSI/MPA	Elong %	RA %	Modulus MSI/GPA	Ult. Load LBS/NEWTONS	0.2% YLD. LBS/NEWTONS
T1	B65833	-320/-196	191.8/1320	148.7/1030	27	39	28.7/198	2630/11699	2039/9071

A/U/R: A=ACCEPTABLE, U=UNACCEPTABLE, R=REPORT

DISPOSITION: Report

Specimen ID	TestLog Number	Orig. Width (in./mm)	Final Width (in./mm)	Orig. Thick (in./mm)	Final Thick (in./mm)	Orig. Dia. (in./mm)	4D Orig GL (in./mm)	4D Final GL (in./mm)	Orig. Area (Sq. In./Sq. mm)	Failure Location/Type	Machine Number	A/U/R
T1	B65833	0.1802/4.57708	0.1437/3.650	0.0761/1.933	0.0582/1.478	0.2511/6.378	0.70/17.78	0.89/22.61	0.04183816/26.992307	WELD/DUCTILE	M9	R

A/U/R: A=ACCEPTABLE, U=UNACCEPTABLE, R=REPORT

KNOWINGLY OR WILLFULLY FALSIFYING OR CONCEALING A MATERIAL FACT ON THIS FORM OR MAKING FALSE, FICTITIOUS OR FRAUDULENT STATEMENTS OR REPRESENTATIONS HEREIN COULD CONSTITUTE A FELONY PUNISHABLE UNDER FEDERAL STATUTES. THIS CERTIFICATE OR REPORT SHALL NOT BE REPRODUCED EXCEPT IN FULL, WITHOUT THE WRITTEN APPROVAL OF WMT&R, INC.

Roy E. Starr/Matt Wojton
____ Technical Services Manager/____ Tensile Supervisor

April 20, 2005

Testing Specialists for Aerospace, Automotive, and Material Testing Fields
Locations in Youngstown, PA U.S.A. ~ Tel. (724) 537-3131 and
Banbury U.K. ~ Tel. +44 (0) 1295 261211

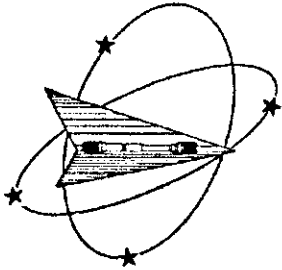

Westmoreland Mechanical Testing & Research, Inc.

P.O. Box 388

Westmoreland Drive

Youngstown, Pa. 15696-0388 U.S.A.

Telephone: 724-537-3131 Fax: 724-537-3151

Website: www.wmtr.com

WMT&R is a technical leader in the material testing industry.



621-01 & 621-02



April 20, 2005

CERTIFICATION

Major Tool & Machine Inc.

Section 2 of 2

WMT&R Report No. 5-25008

P.O. No. P05-01764

TENSILE RESULTS: ASME Section IX and AWS B2.1, ASTM E21-03a

SOAK TIME: 5 Minutes

SPEED OF TESTING: 0.0050 in./in./min., 0.0500 in./min./in.

MATERIAL: Metrode ER316Mnnf

DISPOSITION: Report

Specimen ID	TestLog Number	Temp. °F/°C	UTS KSI/MPA	0.2% YS KSI/MPA	Elong %	RA %	Modulus MSI/GPA	Ult. Load LBS/NEWTONS	0.2% YLD. LBS/NEWTONS
T2	B65834	-320/-196	204.7/1410	156.5/1080	29	34	29.9/206	5095/22664	3894/17323

A/U/R: A=ACCEPTABLE, U=UNACCEPTABLE, R=REPORT

DISPOSITION: Report

Specimen ID	TestLog Number	Orig. Dia. (in./mm)	Final Dia. (in./mm)	4D Orig GL (in./mm)	4D Final GL (in./mm)	Orig. Area (Sq. In./Sq. mm)	Failure Location/Type	Machine Number	A/U/R
T2	B65834	0.1780/4.521	0.1444/3.668	0.70/17.78	0.90/22.86	0.02488456/16.054520	WELD/DUCTILE	M9	R

A/U/R: A=ACCEPTABLE, U=UNACCEPTABLE, R=REPORT

KNOWINGLY OR WILLFULLY FALSIFYING OR CONCEALING A MATERIAL FACT ON THIS FORM OR MAKING FALSE, FICTITIOUS OR FRAUDULENT STATEMENTS OR REPRESENTATIONS HEREIN COULD CONSTITUTE A FELONY PUNISHABLE UNDER FEDERAL STATUTES. THIS CERTIFICATE OR REPORT SHALL NOT BE REPRODUCED EXCEPT IN FULL, WITHOUT THE WRITTEN APPROVAL OF WMT&R, INC.

 Roy E. Starr/Matt Wojton
 Technical Services Manager / Tensile Supervisor

 April 20, 2005

Testing Specialists for Aerospace, Automotive, and Material Testing Fields
 Locations in Youngstown, PA U.S.A. ~ Tel. (724) 537-3131 and
 Banbury U.K. ~ Tel. +44 (0) 1295 261211

WESTMORELAND MECHANICAL TESTING & RESEARCH, Inc

Stress vs. Strain

Phone: (724)537-3131

Customer: Major Tool & Machine Inc.
WMT&R Report: 5-25008

P.O. No.: P05-01764
PQR No.: 434
Welder: Jason Bever #465

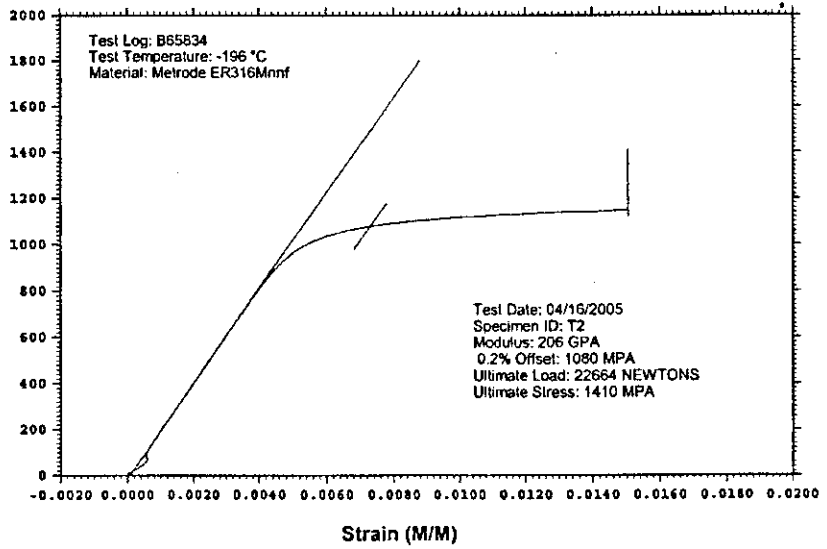
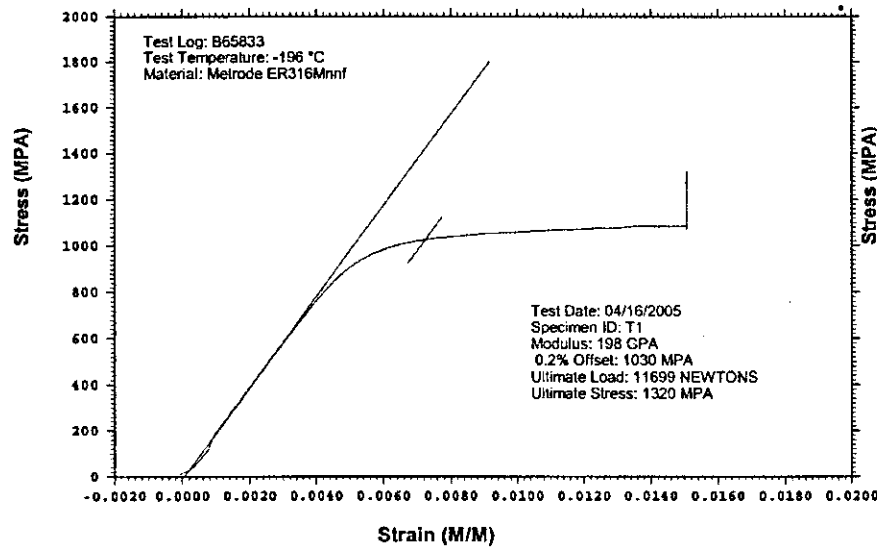
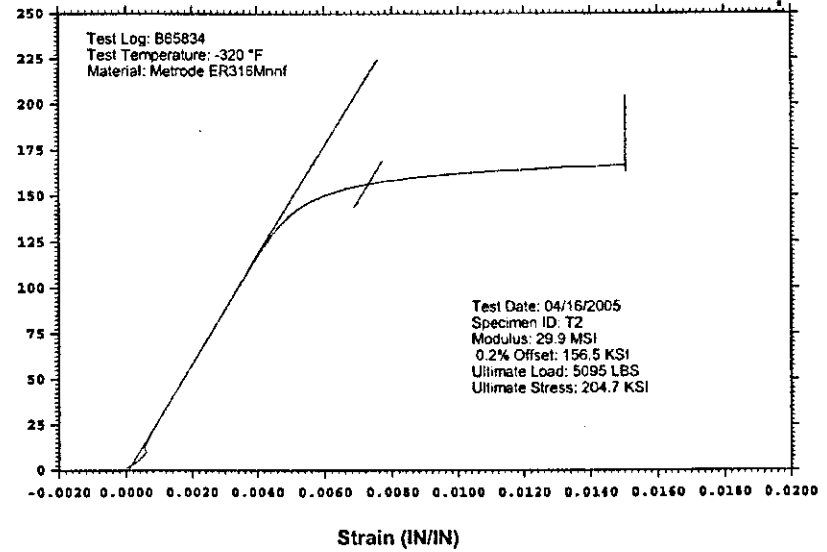
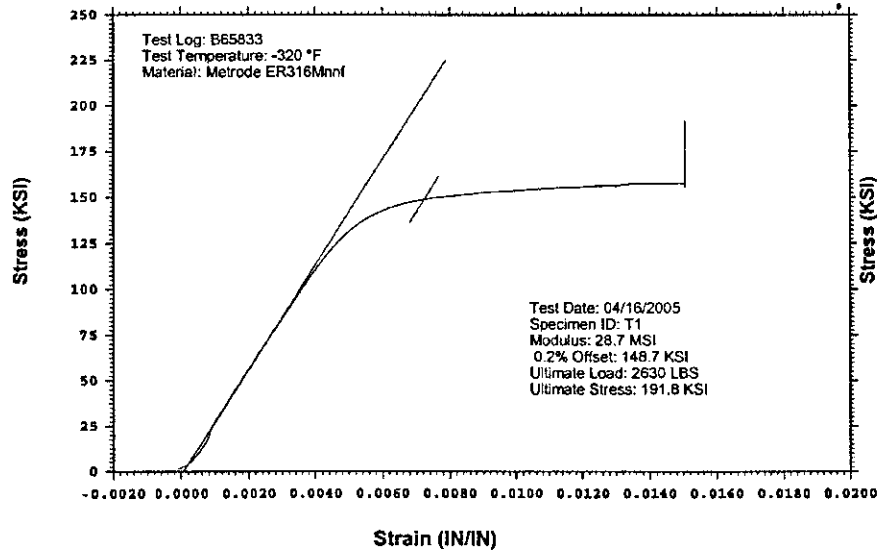

KNOWINGLY OR WILLFULLY FALSIFYING OR CONCEALING A MATERIAL FACT ON THIS FORM OR MAKING FALSE, FICTITIOUS OR FRAUDULENT STATEMENTS OR REPRESENTATIONS HEREIN COULD CONSTITUTE A FELONY PUNISHABLE UNDER FEDERAL STATUTES.

INSPECTION DATA CHECKLIST

Quality Assurance Documentation for Part ID: SE141-116 - Item: 20

Workorder: 65707/5-0 Sub:1 Op:40

Part: SE141-116 - MODULAR COIL WINDING FORM TYPE-C - PRODUCTION MODULAR COIL WINDING FORM TYPE-C

Drawing ID: SE141-116 Rev: 7		INSPECTION INSTRUCTIONS			RESULTS		INSPECTED BY			
SHEET	ZONE	CHARACTERISTIC	GAGE/EQUIP	BY	SAMPLE	SER#	DATA/REMARKS	INSP	VERFD	AUDIT
*		RECORD MAG PERMEABILITY RANGE (IN-PROCESS INSPECTION)	MASTER GAGE	QA		J-1165	<1.02	854-R.U		
(10)								03-08-06		

A

Quality Assurance Documentation for Part ID: SE141-116 - Item: 21

Workorder: 65707/5-0 Sub:1 Op:88

Part: SE141-116 - MODULAR COIL WINDING FORM TYPE-C - PRODUCTION MODULAR COIL WINDING FORM TYPE-C

Drawing ID: SE141-116 Rev: 8		INSPECTION INSTRUCTIONS			RESULTS		INSPECTED BY				
SHEET	ZONE	CHARACTERISTIC	GAGE/EQUIP	BY	SAMPLE	SER#	DATA/REMARKS	INSP	VERFD	AUDIT	
*		VERIFY CLEARANCE BELOW VPI GROOVE ON BOTH SIDES OF THE T SECTION USING MTMFX-3473		MFG		MTMFX-3473	ACCEPT	219-T.L			A
(10)								04-12-06			
*		22 PLACES DATUM E FLANGE VERIFY 2" CLEARANCE ABOVE 3" COUNTERBORE SURFACE USING MTMFX-3564.		MFG		MTMFX-3564	ACCEPT	219-T.L			A
(20)								04-12-06			
*		26 PLACES DATUM D FLANGE VERIFY 2" CLEARANCE ABOVE 3" COUNTERBORE SURFACE USING MTMFX-3564.		MFG		MTMFX-3564	ACCEPT	219-T.L			A
(30)								04-12-06			
6*	F3	VERIFY THAT 1" DIAMETER COOLING HOLES PASS COMPLETELY THROUGH CASTING WITH NO INTERFERENCE FROM CASTING STOCK.		MFG	4	VISUAL	ACCEPT	219-T.L			A
(40)								04-12-06			
9*	D7	VERIFY THAT 1" DIAMETER COOLING HOLES PASS COMPLETELY THROUGH CASTING WITH NO INTERFERENCE FROM CASTING STOCK.		MFG	4	VISUAL	ACCEPT	219-T.L			A
(50)								04-12-06			
9*	F3	VERIFY THAT 1" DIAMETER COOLING HOLES PASS COMPLETELY THROUGH CASTING WITH NO INTERFERENCE FROM CASTING STOCK.		MFG	4	VISUAL	ACCEPT	219-T.L			A
(60)								04-12-06			

Nondestructive Test

Certification for Liquid Penetrant Examination

Quality Assurance Documentation for Part ID: SE141-116 - Item: 22

1458 E. 19th Street, Indianapolis, In 46218
 TEL:(317)636-6433 FAX:(317)634-9420

Date of Inspection: 04/12/2006 **Type of Material:** CAST STAINLESS **NDT#:** 16421

Stage of Inspection: <input type="checkbox"/> Incoming Inspection <input type="checkbox"/> In-Process Inspection <input type="checkbox"/> After Repair <input checked="" type="checkbox"/> Final Inspection	Manufacturing Process: <input type="checkbox"/> Weldment <input checked="" type="checkbox"/> Casting <input type="checkbox"/> Bar Stock <input type="checkbox"/> Plate <input type="checkbox"/> Forging <input type="checkbox"/> Other	Surface Condition: <input checked="" type="checkbox"/> Machined <input type="checkbox"/> Rough <input type="checkbox"/> Other FINAL MACHINED	Test Being Run to: <input checked="" type="checkbox"/> Router Instructions <input checked="" type="checkbox"/> Drawing <input type="checkbox"/> Test Plan <input type="checkbox"/> Technique Card SEE NOTES	Heat Treated: <input type="checkbox"/> Yes <input checked="" type="checkbox"/> No
--	--	---	---	--

Part Information: MTM Job Number: 65707/5.0 -Sub:1 -Op:100 Resource ID: 810-LIQUID PENETRANT INSPE Part ID: SE141-116 Part Name: MODULAR COIL WINDING FOR Serial Number: Customer P.O.: S005242-F Customer Unit/Plant:	Test Results: Quantity Inspected: 1 Quantity Accepted: 0 Quantity Rejected: 1 Run Hours: 0.0	Inspection Results: Customer N/C #: <input type="checkbox"/> Accepted <input checked="" type="checkbox"/> Rejected <input type="checkbox"/> N/C-Report <input type="checkbox"/> Rework MTM N/C #: 19587
--	---	--

Customer Inspection Plan: SEE NOTES Test Step: Revision: Material Test Number:	Inspection Criteria: Customer Specification: ASTM A903/A903M MTM Spec Number: PS582 (REF NDT-WI-09) Acceptance Standard: ASTM A903 (SEE NOTES)
---	---

Inspection Materials Used: Manufacturer: SHERWIN Type of Penetrant: DP-51 Batch Number: 41-E47 Developer: D-100 Batch Number: 65-C6	Penetrant Examination Processes: Type: II (Visible) / Dwell Time: 15 Minutes Method: A (Water Wash) Method of Drying: Forced Air Fan Form: e (nonaqueous for Type II visible dye) / Dwell Time: 15 Min
--	---

Inspection Requirements:

100 % of all accessible surfaces Joint Preps Root Pass Back Gouge Cover Pass Other

Notes:

INSPECT 100% OF SURFACES ON PRODUCTION MODULAR COIL WINDING FORM TYPE-C.
 SPECIFICATION: ASTM A903/A903M
 METHOD: ASTM E165

ACCEPTANCE CRITERIA: ASTM A903/A903M LEVEL I FOR MACHINED SURFACES INCLUDING THE ENTIRE "T" SECTION (HIGH STRESS AREAS)

PART HAS REJECTABLE INDICATIONS PER CUSTOMER REQUIREMENTS ON MACHINED AND AS CAST SURFACES. SEE NCR-19587 AND PHOTOS FOR MORE DETAILED INFO.

This is to certify that the pieces specified have been inspected in accordance with the specifications shown.

Inspector: 581-D.EDWARDS

Date: 04/12/2006

Douglas D. Edwards Level II



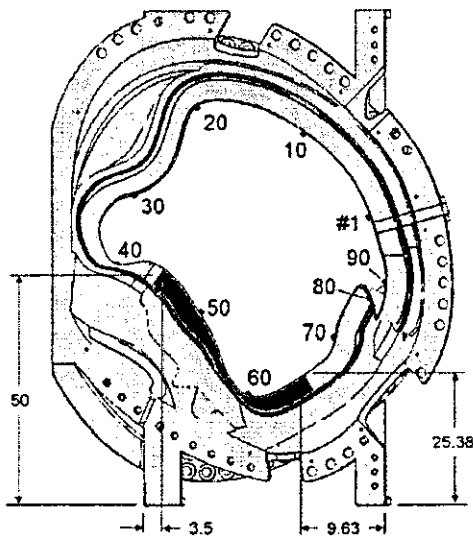

65707/5.0/1/110/818
SE141-116 rev.8
Page 2 of 2
4/13/06
NCR 19607

Figure 7-2 - High Stress Region Identification for Type-C MCWF

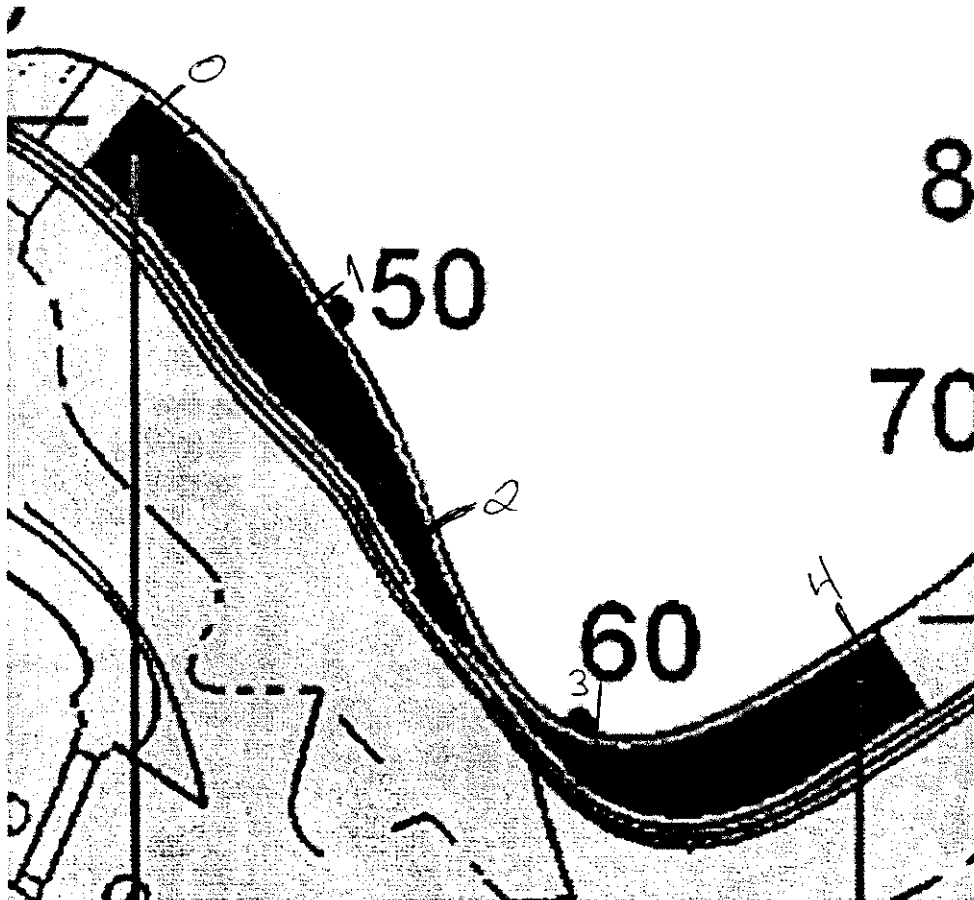

Quality Assurance Documentation for Part ID: SE141-116 - Item: 24

Workorder: 65707/5-0 Sub:1 Op:120

Part: SE141-116 - MODULAR COIL WINDING FORM TYPE-C - PRODUCTION MODULAR COIL WINDING FORM TYPE-C

Drawing ID: SE141-116 Rev: 8			INSPECTION INSTRUCTIONS			RESULTS		INSPECTED BY			
SHEET	ZONE	CHARACTERISTIC	GAGE/EQUIP	BY	SAMPLE	SER#	DATA/REMARKS	INSP	VERFD	AUDIT	
*		DATUM - E - SIDE MAG PERMEABILITY TO BE NO GREATER THAN 1.02μ. CHECK 3 PLACES ADJACENT TO EVERY 5TH HOLE IN T SECTION.	MASTER GAGE	QA		J-1270	57 PLACES CHECKED. ALL <1.02	854-R.U			A
(10)								04-18-06			
*		DATUM - D - SIDE MAG PERMEABILITY TO BE NO GREATER THAN 1.02μ. CHECK 3 PLACES ADJACENT TO EVERY 5TH HOLE IN T SECTION.	MASTER GAGE	QA		J-1270	57 PLACES CHECKED. ALL <1.02	854-R.U			A
(20)								04-18-06			

Quality Assurance Documentation for Part ID: SE141-116 - Item: 25

Workorder: 65707/5-0 Sub:1 Op:130

Part: SE141-116 - MODULAR COIL WINDING FORM TYPE-C - PRODUCTION MODULAR COIL WINDING FORM TYPE-C

Drawing ID: SE141-103 Rev: 3			INSPECTION INSTRUCTIONS			RESULTS		INSPECTED BY			
SHEET	ZONE	CHARACTERISTIC	GAGE/EQUIP	BY	SAMPLE	SER#	DATA/REMARKS	INSP	VERFD	AUDIT	
2* (10)	D3	Ø.001 - Ø.002 CHECK CLEARANCE OF ITEM 5 TO ITEM 6.		QA		FEELER GAGE	DIAMETRICAL GAP C CKS UP TO .022"	242-M.G 04-26-06			R
* (15)		THE GAP BETWEEN THE POLOIDAL BREAK BUSHINGS AND FLANGE SHAL BE LESS THAN .002"		QA		FEELER GAGE	ACCPET	242-M.G 04-26-06			A
2* (20)	F2	ENSURE THAT THE CUMULATIVE GAP AT ANY SINGLE CROSS SECTION OF THE POLOIDAL FLANGE ELEMENTS IS LESS THAN .005".		QA		FEELER GAGE	LESS THAN .001"	242-M.G 04-26-06			A
* (30)		THE MAX. GAP AT THE POLOIDAL BREAK PERIMETER IS .015" AND CANNOT EXCEED 1/8" FROM THE EDGE		QA		FEELER GAGE	MAX GAP IS .006"	242-M.G 04-26-06			A







Quality Assurance Documentation for Part ID: SE141-116 - Item: 26

Workorder: 65707/5-0 Sub:1 Op:132

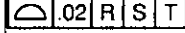
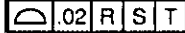
Part: SE141-116 - MODULAR COIL WINDING FORM TYPE-C - PRODUCTION MODULAR COIL WINDING FORM TYPE-C

Drawing ID: SE141-116 Rev: 8			INSPECTION INSTRUCTIONS			RESULTS		INSPECTED BY		
SHEET	ZONE	CHARACTERISTIC	GAGE/EQUIP	BY	SAMPLE	SER#	DATA/REMARKS	INSP	VERFD	AUDIT
1* (10)	E8	47.19 ± .03	CMM	QA		00064	47.17	339-E.R 04-26-06		A
1* (20)	B8	47.19 ± .03	CMM	QA		00064	47.18	339-E.R 04-26-06		A
1* (30)	D6	47.19 ± .03	CMM	QA		00064	47.18	339-E.R 04-26-06		A
1* (40)	C6	47.19 ± .03	CMM	QA		00064	47.19	339-E.R 04-26-06		A
1* (50)	E6	∥.02 A	CMM	QA		00064	.01	339-E.R 04-26-06		A
1* (60)	B6	∥.02 A	CMM	QA		00064	.02	339-E.R 04-26-06		A
2* (80)	H6	2X R.187 +.025 -.005	PIN GAGE	QA		J-651-2	.184 TO .188	533-B.C 04-20-06		A
2* (90)	G8	2X .03 X 45°		QA		VISUAL	ACCEPT	339-E.R 04-26-06		A
2* (100)	G8	.40 ± .010	CALIPER	QA		J-707	.39 TO .41	339-E.R 04-26-06		A
2* (110)	G8	2X .030 X 45°		QA		VISUAL	ACCEPT	339-E.R 04-26-06		A
2* (120)	F7	2X .32	CALIPER	QA		P-5075	.310 TO .330	533-B.C 04-20-06		A
2* (130)	F7	2X R.11	PIN GAGE	QA		J-652-1	.105 TO .110	533-B.C 04-20-06		A
2* (140)	G6	⊖.2 R S T P TO M	CMM	QA		00064	-.002 TO .086	339-E.R 04-26-06		A
2* (150)	G6	4.790 OR SHELL INTERSECT. VERIFY USING TEMPLATE PER DRAWING NOTE 16 (MTMFX-3473)		QA		MTMFX-3473	ACCEPT	339-E.R 04-26-06		A
2*	G3	⊖.2 R S T	CMM	QA		00064	-.003 TO .074	339-E.R		A

INSPECTION DATA CHECKLIST

(160)		Q TO N						04-26-06			
2*	G3	4.790 OR SHELL INTERSECT. VERIFY USING TEMPLATE PER DRAWING NOTE 16 (MTMFX-3473)		QA		MTMFX-3473	ACCEPT	339-E.R		A	
(170)								04-26-06			
2*	E6	 M TO MI	CMM	QA		00064	-.034 TO .038 [N/C: 19713]	339-E.R		R	
(180)								04-26-06			
2*	F3	 N TO NI	CMM	QA		00064	-.024 TO .030 [N/C: 19713]	339-E.R		R	
(182)								04-26-06			
2*	E5	 MI TO NI	CMM	QA		00064	-.046 TO .019	339-E.R		A	
(185)								04-26-06			
Drawing ID: NCSX-CSPEC-141-03 Rev: 11			INSPECTION INSTRUCTIONS			RESULTS			INSPECTED BY		
SHEET	ZONE	CHARACTERISTIC	GAGE/EQUIP	BY	SAMPLE	SER#	DATA/REMARKS	INSP	VERFD	AUDIT	
4*	3.1.1.	^{/125} THE TWO "L" MACHINED SURFACES OF TEE.	PROFILOMETER	QA		J-1109	33 TO 55	533-B.C		A	
(188)								04-20-06			
Drawing ID: SE141-116 Rev: 8			INSPECTION INSTRUCTIONS			RESULTS			INSPECTED BY		
SHEET	ZONE	CHARACTERISTIC	GAGE/EQUIP	BY	SAMPLE	SER#	DATA/REMARKS	INSP	VERFD	AUDIT	
2*	B5	 96X .375-16 UNC .750 DEEP .625 C'BORE .188 DEEP	CMM	QA	50%	00064	.018 TO .075 [N/C:1 9713]	339-E.R		R	
(190)								04-26-06			
2*	B5	.375-16 UNC .750 DEEP GAGE 100% OF THE HOLES AND VERIFY CLEANLINESS.	THREAD PLUG GA	QA	100%	A-444	ACCEPT	339-E.R		A	
(195)								04-26-06			
2*	B4	2X .06-.09 X 45°	CALIPER	QA		P-5075	.06" TO .09 (SOME A REAS ARE ROUNDED E TO GRINDING) [N/C :19713]	242-M.G		R	
(200)								04-26-06			
3*	G7	 8X Ø1-8 UNC THRU	CMM	QA		00064	.006 TO .043 [N/C:1 9713]	339-E.R		R	
(210)								04-26-06			
3*	H3	 DATUM -E- FLANGE	CMM	QA		00064	.019 [N/C:19713]	339-E.R		R	
(230)								04-26-06			
3*	H4	^{/125} DATUM -E- FLANGE	PROFILOMETER	QA		J-1109	6 TO 30	533-B.C		A	
(240)								04-20-06			
3*	F3		CMM	QA		00064	.037 [N/C:19713]	339-E.R		R	

INSPECTION DATA CHECKLIST

(250)		DATUM -D- FLANGE					04-26-06		
3* (260)	F3	$\sqrt{125}$ DATUM -D- FLANGE	PROFILOMETER	QA	J-1109	25 TO 79	533-B.C 04-20-06		A
3* (280)	E4	$\phi .01$ A B C 8X Ø1.13 THRU BACK SPOT FACE Ø2.38 MIN DEPTH FOR C'UP	CMM	QA	00064 MTMFX-3564	.003 TO .017 / ACCE PT SPOT [N/C:19713]	339-E.R 04-26-06		R
4* (290)	H8	$\phi .060$ D A N 3X Ø1.885 THRU	CMM	QA	00064	.039 TO .043	339-E.R 04-26-06		A
4* (291)	H8	3X Ø1.885 +/- .003 Ø3.00 BACK SPOTFACE VERIFY MIN CLEANUP	CMM DIAL BORE GAGE	QA	00064 J-1400	1.888 TO 1.892 [N/C :19713]	533-B.C 04-20-06		R
4* (300)	H7	$\phi \phi .06$ D A N 3X 2.000" COUNTERBORE 1.00 DP	CMM	QA	00064	.020 TO .022	339-E.R 04-26-06		A
4* (305)	H7	Ø \square 2.000 - 2.001	DIAL BORE GAGE	QA	J-1401	1.999 TO 2.001	339-E.R 04-26-06		A
4* (310)	H6	$\phi \phi .060$ D A N 17X Ø1.885 THRU	CMM	QA	00064	.035 TO .055	339-E.R 04-26-06		A
4* (311)	H6	3X Ø1.885 +/- .003 THRU Ø3.00 BACK SPOTFACE VERIFY MIN CLEANUP	CMM DIAL BORE GAGE	QA	00064 J-1400	1.888 TO 1.895 [N/C :19713]	533-B.C 04-20-06		R
4* (320)	H5	$\phi \phi .060$ D A N 3X Ø1.13	CMM	QA	00064	.015 TO .020	339-E.R 04-26-06		A
4* (321)	H5	3X Ø1.13 +/- .010 Ø2.38 BACK SPOTFACE VERIFY MIN CLEANUP	CMM	QA	00064	1.1248 TO 1.1278	533-B.C 04-20-06		A
4* (340)	E6	$\phi \phi .060$ D A N 3X Ø1.375-6 UNC THRU	CMM	QA	00064	.026 TO .044	339-E.R 04-26-06		A
4* (350)	E6	$\phi \phi .060$ D A N 5X Ø1.885 THRU	CMM	QA	00064	.052 TO .056	339-E.R 04-26-06		A
4* (351)	E6	5X Ø1.885 +/- .003 THRU Ø3.00 BACK SPOTFACE VERIFY MIN CLEANUP	CMM	QA	00064 MTMFX-3564	1.8857 TO 1.888 / A CCEPT SPOT	339-E.R 04-26-06		A

INSPECTION DATA CHECKLIST

4* (360)	D4	\varnothing .060 D A N Ø1.885 THRU	CMM	QA	00064	.057	339-E.R 04-26-06		A
4* (361)	D4	Ø1.885 +/- .003 THRU Ø3.00 BACK SPOTFACE VERIFY MIN CLEANUP	CMM DIAL BORE GAGE	QA	00064 J-1400	1.890 / ACCEPT SPOT [N/C:19713]	339-E.R 04-26-06		R
4* (370)	B5	\varnothing .060 D A N 3X Ø1.13	CMM	QA	00064	.005 TO .017	339-E.R 04-26-06		A
4* (371)	B5	3X Ø1.13 +/- .010 Ø2.38 BACK SPOTFACE VERIFY MIN CLEANUP	CMM	QA	00064 MTMFX-3564	1.1253 TO 1.1255 / ACCEPT SPOT	339-E.R 04-26-06		A
4* (375)	D1	12X .25-20 UNC -2B	THREAD PLUG GA	QA	A-234	ACCEPT	533-B.C 04-20-06		A
4* (376)	G8	\varnothing .06 D A N 12X .25-20 UNC -2B SUMMARY OF HOLE POSITIONS. ACTUAL FEATURE CONTROL FRAME IS NOT ON DRAWING.	CMM	QA	00064	.009 TO .031	339-E.R 04-26-06		A
5* (380)	E8	\varnothing .060 E A J Ø1.885 THRU	CMM	QA	00064	.007	339-E.R 04-26-06		A
5* (381)	E8	Ø1.885 +/- .003 THRU Ø3.00 BACK SPOTFACE VERIFY MIN CLEANUP	CMM	QA	00064 MTMFX-3564	1.888 / ACCEPT SPOT	339-E.R 04-26-06		A
5* (400)	F6	\varnothing .060 E A J 3X Ø1.375-6 UNC THRU	THREAD PLUG GA	QA	A-375	ACCEPT	533-B.C 04-20-06		A
5* (410)	F6	\varnothing .06 E A J 3X 2.000" COUNTERBORE 1.00 DP	CMM	QA	00064	.009 TO .019	339-E.R 04-26-06		A
5* (412)	F6	Ø 2.000 - 2.001	DIAL BORE GAGE	QA	J-1401	1.999 TO 2.001	339-E.R 04-26-06		A
5* (415)	F7	7X 1/4-20 UNC -2B	THREAD PLUG GA	QA	A-715	ACCEPT	339-E.R 04-26-06		A
5* (420)	F7	\varnothing .06 E A J 7X 1/4-20 UNC -2B SUMMARY OF HOLE POSITIONS. ACTUAL FEATURE CONTROL FRAME IS NOT ON DRAWING.	CMM	QA	00064	.006 TO .028	339-E.R 04-26-06		A



INSPECTION DATA CHECKLIST

5* (430)	E7	Φ \emptyset .060 E A J 24X \emptyset 1.885 THRU	CMM	QA		00064	.005 TO .023	339-E.R 04-26-06			A
5* (431)	E7	24X \emptyset 1.885 +/- .003 THRU \emptyset 3.00 BACK SPOTFACE VERIFY MIN CLEANUP	CMM DIAL BORE GAGE	QA		00064 J-1400	1.882 TO 1.8893 / A CCEPT SPOT [N/C:197 13]	339-E.R 04-26-06			R
5* (440)	E7	Φ \emptyset .060 E A J 3X \emptyset 1.5 TO 2.00 DEEP \emptyset 3.00 TO 1.00 DEEP	CMM	QA		00064	.010 TO .016	339-E.R 04-26-06			A
5* (450)	D7	3X \emptyset 1.885 +/- .003 THRU \emptyset 3.00 BACK SPOTFACE VERIFY MIN CLEANUP	CMM	QA		00064 MTMFX-3564	1.883 TO 1.886 / AC CEPT SPOT	339-E.R 04-26-06			A
6* (470)	E3	4X \emptyset 1.00 THRU	PIN GAGE	QA		J-921	1.0	533-B.C 04-20-06			A
8* (650)	G7	4.00 \pm .010	CALIPER	QA		J-1389	3.960 [N/C:19713]	533-B.C 04-20-06			R
8* (750)	D7	6X \emptyset .375-16 UNC TO .75 DEEP .03 X 45° CHAMFER	THREAD PLUG GA	QA		A-444 VISUAL	ACCEPT	339-E.R 04-26-06			A
8* (760)	D7	13.6 °		QA		VISUAL	SEE IGES	339-E.R 04-26-06			A
8* (770)	D7	5.88 VERIFY THAT PAD MEETS THE MINIMUM OF 5.88	CALIPER	QA		J-1389	6.900	533-B.C 04-20-06			A
8* (780)	D7	2.19 \pm .010		QA		VISUAL	SEE IGES	339-E.R 04-26-06			A
8* (790)	D7	2.19 \pm .010		QA		VISUAL	SEE IGES	339-E.R 04-26-06			A
8* (830)	C8	2X 1.56 \pm .010 THRU	CALIPER	QA		J-1389	1.555 TO 1.565	533-B.C 04-20-06			A
8* (850)	C8	2X 7.50 \pm .010 THRU	CALIPER	QA		J-1389	7.495 TO 7.502	533-B.C 04-20-06			A
8* (860)	C8	8X R.25	PIN GAGE	QA		J-652-1	.250	533-B.C 04-20-06			A

INSPECTION DATA CHECKLIST

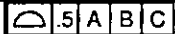
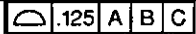
8* (870)	C8	2X 2.52 ± .010	CMM	QA		00064	SEE IGES	339-E.R 04-26-06			A
9* (900)	E7	2.54 ± .010	SCALE	QA		J-922	ACCEPT	339-E.R 04-26-06			A
9* (910)	E7	5.08 ± .010	SCALE	QA		J-922	5.08	339-E.R 04-26-06			A
9* (920)	F3	4X Ø1.0 THRU VERIFY THAT HOLES BREAK COMPLETELY THROUGH INSIDE OF CASTING	PIN GAGE	QA		J-921	1.0	533-B.C 04-20-06			A
9* (930)	F3	2X Ø .50 ± .010 THRU	PIN GAGE	QA		J-652-3	.500	533-B.C 04-20-06			A
9* (940)	E3	2.44 ± .010	SCALE	QA		J-922	2.45	339-E.R 04-26-06			A
9* (950)	E3	1.22 ± .010	SCALE	QA		J-922	ACCEPT	339-E.R 04-26-06			A
9* (960)	C7	4X Ø1.0 THRU VERIFY THAT HOLES BREAK COMPLETELY THROUGH INSIDE OF CASTING	PIN GAGE	QA		J-921	1.0	533-B.C 04-20-06			A
9* (970)	C6	2X Ø.25 T.C. HOLE	PIN GAGE	QA		J-652-1	.250	533-B.C 04-20-06			A
Drawing ID: SE141-116 Rev: 7			INSPECTION INSTRUCTIONS			RESULTS			INSPECTED BY		
SHEET	ZONE	CHARACTERISTIC	GAGE/EQUIP	BY	SAMPLE	SER#	DATA/REMARKS	INSP	VERFD	AUDIT	
10* (980)	C8		CMM	QA		00064	.0208 TO .2076 [N/C :19713]	339-E.R 04-26-06			R
Drawing ID: SE141-116 Rev: 8			INSPECTION INSTRUCTIONS			RESULTS			INSPECTED BY		
SHEET	ZONE	CHARACTERISTIC	GAGE/EQUIP	BY	SAMPLE	SER#	DATA/REMARKS	INSP	VERFD	AUDIT	
10* (990)	D5	 DATUM -D- SIDE INNER CAST	CMM	QA		00064	-.0006 TO -.3923 [N /C:19713]	339-E.R 04-26-06			R
Drawing ID: SE141-116 Rev: 7			INSPECTION INSTRUCTIONS			RESULTS			INSPECTED BY		
SHEET	ZONE	CHARACTERISTIC	GAGE/EQUIP	BY	SAMPLE	SER#	DATA/REMARKS	INSP	VERFD	AUDIT	
10* (1010)	C4	 DATUM -E- SIDE LARGE WING	CMM	QA		00064	.020 TO .101 [N/C:1 9713]	339-E.R 04-26-06			R
Drawing ID: SE141-116 Rev: 8			INSPECTION INSTRUCTIONS			RESULTS			INSPECTED BY		

INSPECTION DATA CHECKLIST

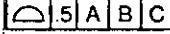
SHEET	ZONE	CHARACTERISTIC	GAGE/EQUIP	BY	SAMPLE	SER#	DATA/REMARKS	INSP	VERFD	AUDIT	
10* (1030)	D1	 5 A B C DATUM -E- SIDE INNER CAST	CMM	QA		00064	-.256 TO .258 [N/C: 19713]	339-E.R 04-26-06			R
Drawing ID: SE141-116 Rev: 7			INSPECTION INSTRUCTIONS			RESULTS		INSPECTED BY			
SHEET	ZONE	CHARACTERISTIC	GAGE/EQUIP	BY	SAMPLE	SER#	DATA/REMARKS	INSP	VERFD	AUDIT	
10* (1035)	E1	MACHINE / GRIND THIS AREA TO PROFILE OF +.05/-.10	CMM	QA		00064	-.213 TO .495 [N/C: 19713]	339-E.R 04-26-06			R
Drawing ID: NCSX-CSPEC-141-03 Rev: 10			INSPECTION INSTRUCTIONS			RESULTS		INSPECTED BY			
SHEET	ZONE	CHARACTERISTIC	GAGE/EQUIP	BY	SAMPLE	SER#	DATA/REMARKS	INSP	VERFD	AUDIT	
4* (1040)	3.1.1.	UOS ALL MACHINED SURFACES TO BE 250 RMS SURFACE FINISH RECORD RANGE	PROFILOMETER	QA		J-1109	150 TO 250 [N/C:197 13]	242-M.G 04-26-06			A
Drawing ID: SE141-116 Rev: 8			INSPECTION INSTRUCTIONS			RESULTS		INSPECTED BY			
SHEET	ZONE	CHARACTERISTIC	GAGE/EQUIP	BY	SAMPLE	SER#	DATA/REMARKS	INSP	VERFD	AUDIT	
1* (1050)		NOTE 9 RECORD THE WEIGHT OF THE PART 6000LBS MAX	SCALE	QA		2270	5,580	242-M.G 04-26-06			A

Nondestructive Test Certification for Liquid Penetrant Examination

Quality Assurance Documentation for Part ID: SE141-116 - Item: 27

Date of Inspection: 04/24/2006

Type of Material: CAST STAINLESS

NDT#: 16422

Stage of Inspection: <input type="checkbox"/> Incoming Inspection <input type="checkbox"/> In-Process Inspection <input checked="" type="checkbox"/> After Repair <input type="checkbox"/> Final Inspection	Manufacturing Process: <input type="checkbox"/> Weldment <input checked="" type="checkbox"/> Casting <input type="checkbox"/> Bar Stock <input type="checkbox"/> Plate <input type="checkbox"/> Forging <input type="checkbox"/> Other	Surface Condition: <input checked="" type="checkbox"/> Machined <input type="checkbox"/> Rough <input checked="" type="checkbox"/> Other BLENDED SMOOTH	Test Being Run to: <input checked="" type="checkbox"/> Router Instructions <input checked="" type="checkbox"/> Drawing <input type="checkbox"/> Test Plan <input type="checkbox"/> Technique Card SEE NOTES	Heat Treated: <input type="checkbox"/> Yes <input checked="" type="checkbox"/> No
--	--	--	---	--

Part Information: MTM Job Number: 65707/5.0 -Sub:14 -Op:20 Resource ID: 810-LIQUID PENETRANT INSPE Part ID: SE141-116 Part Name: MODULAR COIL WINDING FOR Serial Number: Customer P.O.: S005242-F Customer Unit/Plant:	Test Results: Quantity Inspected: 1 Quantity Accepted: 1 Quantity Rejected: 0 Run Hours: 0.0	
--	---	--

Customer Inspection Plan: SEE NOTES Test Step: Revision: Material Test Number:	Inspection Criteria: Customer Specification: ASTM A903/A903M MTM Spec Number: PS582 (REF NDT-WI-09) Acceptance Standard: ASTM A903 (SEE NOTES)
---	--

Inspection Materials Used: Manufacturer: SHERWIN Type of Penetrant: DP-51 Batch Number: 41-E47 Developer: D-100 Batch Number: 520-H6	Penetrant Examination Processes: Type: II (Visible) / Dwell Time: 15 Minutes Method: C (Solvent Wipe) Method of Drying: Normal Evaporation Form: e (nonaqueous for Type II visible dye) / Dwell Time: 15 Min
--	---

Inspection Requirements:

% of all accessible surfaces Joint Preps Root Pass Back Gouge Cover Pass Other

Notes:

INSPECT WELD REPAIR AREAS, AS INSTRUCTED BY ENGINEERING.
 SPECIFICATION: ASTM A903/A903M
 METHOD: ASTM E165

ACCEPTANCE CRITERIA: ASTM A903/A903M LEVEL I FOR MACHINED SURFACES INCLUDING THE ENTIRE "T" SECTION (HIGH STRESS AREAS)

Note: Please reference NC 19710 for additional information.

This is to certify that the pieces specified have been inspected in accordance with the specifications shown.

Inspector: 581-D.EDWARDS

Date: 04/24/2006

Douglas D. Edwards Level II



Quality Assurance Documentation for Part ID: SE141-116 - Item: 28

Workorder: 65707/5-0 Sub:14 Op:30

Part: SE141-116 - MODULAR COIL WINDING FORM TYPE-C - PRODUCTION MODULAR COIL WINDING FORM TYPE-C

Drawing ID: SE141-116 Rev: 8		INSPECTION INSTRUCTIONS			RESULTS		INSPECTED BY			
SHEET	ZONE	CHARACTERISTIC	GAGE/EQUIP	BY	SAMPLE	SER#	DATA/REMARKS	INSP	VERFD	AUDIT
*		N C 19710 RECORD PERMEABILITY RANGE OF THE SIX REPAIRED AREAS. MAG PERMEABILITY TO BE NO GREATER THAN 1.02μ.	MASTER GAGE	QA		J-1165	LESS THAN 1.02	503-B.H		
(10)								04-26-06		



CERTIFICATE OF TEST

Page 02 of 02

Certification Date
9-JAN-2006

CUSTOMER ORDER NUMBER

PO6-00025

2301 AIRWEST BLVD
PLAINFIELD IN 46168

Invoice Number

T479315

CUSTOMER PART NUMBER

Ship# T731400

SOLD TO: MAJOR TOOL & MACHINE INC	SHIP TO: MAJOR TOOL & MACHINE INC
1458 E 19TH ST	29267
INDIANAPOLIS IN 46218	1458 EAST 19TH STREET
	INDIANAPOLIS IN 46218

Description: 316/316L HRAP BAR	ASTM A479
1 X 3 X 12' R/L	Line Total: 259 LB
HEAT: M11443	ITEM: S22335

THERMAL TREATMENT: OK
 HT TRT QUENCHED 1040 DEG C 30 MIN WATER
 CORROSION: OK
 MACRO: OK
 MICRO1: OK



JAN 09 2006

The above data were transcribed from the manufacturer's Certificate of Test after verification for completeness and specification requirements of the information on the certificate. All test results remain on file subject to examination.

We hereby certify that the material covered by this report will meet the applicable requirements described herein, including any specification forming a part of the description.

The willful recording of false, fictitious, or fraudulent statements in connection with test results may be punishable as a felony under federal statutes.

Material did not come in contact with mercury while in our possession.

DAMIAN GURRI

MANAGER, QUALITY ASSURANCE

ABNAHMEPRUEFZEUGNIS B
INSPECTION CERTIFICATE B
CERTIFICAT DE RECEPTION B

ISO 9001
BSI Registration
No. FM00777



nach/according to/ selon EN 10204-3.1
Blatt/Sheet/Feuille 1 von/Of/De 2

Nr./No./No.: 010.350 05.06.23

Seite/Page/Page: 01/01 16/ACK

Besteller/Purchaser/Commandant
AMB SPECIALITY STEEL, INC.

3304 COLLINS RD, PO BOX 1021
28173 WAXHAW, NC 28173-
USA

Bestell-Nr./Purchaser's Order No./No. de commande
2898/P791235

RS34135
S22335

Unsere Auftrags-Nr./Works Order No./No. de commande d'usine
354.175/USA vom 05.02.23/01/
Anforderungen/Requirements/Cuissance
+ :

Lieferschein/Dispatch note/Avis d'expédition
20/511.846/K vom 05.06.20

Prüfgegenstand/Objekt of tests/Objet d'examen
AISI 316/316L, UNS-S-31600, UNS-S-31603, DIN 1017
STAINLESS STEEL FLAT BARS,
HOT ROLLED, QUENCHED/SOLUTION ANNEALED AND PICKLED

Umfang der Lieferung/Volume of delivery/Liste descriptive

03 FL 76,200MM X 25,400MM
1" X 3" 11,33 - 12,97 FT

Gewicht kg Schmelze Prüf-Nr
Weight/lb No. de soude Test No
Poids/lb Essais
2415.00 M11443 I067
5324,1 LBS

"MATERIAL IS FREE OF MERCURY CONTAMINATION"
"NO WELD REPAIR"

+ :
ASTM A484/A484M-03, ASTM A276-03, AMS-QQ-S-763-98, AMS 5653F-02,
AMS 5648K-02, ASTM A479/A479H-03, ASTM A182/A182M-03, ASTM A193/A193M-03,
ASTM A320/A320M-03, ASME SA479-01, ASME SA 182-00b,

COUNTRY OF ORIGIN: AUSTRIA

Erschmelzungsart/Steelmaking Process/Procédé d'acieration EAF

Kennzeichnung/Marking/Marque

Markenbezeichnung/Grade of Material/nuance du materiel:
Werkstoff Nr./Material No./Materiaux No. X
Schmelztest No./No. de soude X

Besichtigung und Nachmessung: Kein Anstand
Inspection and Checking of Dimensions: satisfactory
Inspection of Control des dimensions: satisfaisant

Ergebnis der Prüfungen/Test Results/Resultat des essais
Die gestellten Anforderungen sind erfüllt.
The material has been furnished in accordance with
the requirements.
Le materiel a été trouve conforme aux exigences.

Zeichen des Lieferwerkes
Brand of Manufacturer
Marque de l'usine



Zeichen des Prüfers
Symbol of Inspector
Symbole de l'inspecteur



BOEHLER
Edelstahl GmbH

(DIN EN 10204-3.1)
CERTIFICATE OF CONFORMANCE

MTM
016

JAN 09 2006

ABNAHMEPRUEFZEUGNIS B
INSPECTION CERTIFICATE B
CERTIFICAT DE RECEPTION B

ISO 9001
BSI Registration
No. FM00777



Ergebnis der Pruefungen/Test results/Resultat des essais
Blatt/Sheet/Feuille 2 Von/Of/De 2

Nr./No./No.: 010.350 05.06.23
Seite/Page/Page: 01/01

Chemische Zusammensetzung/Chemical Composition/Composition chimique (%)

Schmelze Heat No. No. de coulée	C	SI	MN	P	S	CR	MO	NI	V	W
M11443	0,03	0,57	1,25	0,037	0,024	16,84	2,00	10,63	0,03	0,07
CO=0,057 TI= 0,05 AL=0,059 NB=0,010 N = 0,04 CU=0,27										

Mechanische Eigenschaften/Mechanical Properties/Caractéristiques mecaniques

Pruef-Nr Test No L'essai	TEMP ° C	YIELD ST. KSI	TENS. ST KSI	ELONG. A4 %	R/A %
I067	0020	058	075-115	>40	>50
			091	44	71

BRINELLHARDNESS : 194 BHN

MACRO AND MICRO TESTS : SATISFACTORY

CONFUSION-TEST : SATISFACTORY

GRAIN SIZE ACC. TO ASTM E112 : 10

INTERCRYSTALLINE CORROSION TEST ACC. TO ASTM A262 PR.E : SATISFACTORY

HEAT-TREATMENT:

QUENCHED: 1040 ° C - 30 MIN - WATER

Anlagen:
Appareils:
Règles:

BOEHLER
Edelstahl GmbH

DER ARBEITENVERTRÄG
INSPECTOR REPRESENTATIVE



JAN 09 2006

Quality Assurance Documentation for Part ID: SE141-137 - Item: 30

Workorder: 65707/5-0 Sub:9 Op:40

Part: SE141-137 - -

Drawing ID: SE141-137 Rev: 1			INSPECTION INSTRUCTIONS			RESULTS		INSPECTED BY		
SHEET	ZONE	CHARACTERISTIC	GAGE/EQUIP	BY	SAMPLE	SER#	DATA/REMARKS	INSP	VERFD	AUDIT
1*	G2	RECORD MAGNETIC PERMEABILITY. RESULTS TO BE NO GREATER THAN 1.03μ PER RFD 14-011.	MASTER GAGE	QA		J-1165	BETWEEN 1.03 AND 1.05 [N/C:19233]	503-B.H		
(10)								02-08-06		R

Quality Assurance Documentation for Part ID: SE141-138 - Item: 32

Workorder: 65707/5-0 Sub:10 Op:40

Part: SE141-138 - -

Drawing ID: SE141-138 Rev: 1		INSPECTION INSTRUCTIONS			RESULTS		INSPECTED BY			
SHEET	ZONE	CHARACTERISTIC	GAGE/EQUIP	BY	SAMPLE	SER#	DATA/REMARKS	INSP	VERFD	AUDIT
1*	G2	RECORD MAGNETIC PERMEABILITY. RESULTS TO BE NO GREATER THAN 1.03μ PER RFD 14-011.	MASTER GAGE	QA		J-1165	BETWEEN 1.03 AND 1.05 [N/C:19234]	503-B.H		
(10)								02-08-06		R

Employees: 219-T.Laird / 242-M.Griffith / 339-E.Root / 503-B.Houk / 533-B.Clevenger / 840-G.Masood / 854-R.Upchurch