

Energy Industries of Ohio

Contract # S005242-F

Modular Coil Winding Form

A-2 Documentation Package

8/29/06

This A-2 Documentation consists of:

Part 1

Final documentation package Metal Tek Intl. – Pages 3-63
Latest revision 7/20/2006
Foundry documentation

Part 2

Final documentation package Major Tool - Pages 64 - 117
Latest revision 8/29/2006
Machine shop documentation

NOTE - MTM – new EIO TOC is on page 65. Use this as a reference for finding files in MTM portion of Doc package.

Part 3

Metal Tek radiographic films from part 1 (shipped to PPPL)

Major Tool radiographic films from part 2 (shipped to PPPL)

Energy Industries of Ohio

Contract # S005242-F

Modular Coil Winding Forms

A-2 Documentation Package

**Part 1 – Metal Tek International
Casting Data Package**

7/20/06

**Note – Document #'s listed in the TOC (page 4) are not necessarily the same as the number hand written on the top of the document. Please use page # to find relevant document.

A-2 Documentation Package

List of Documents 7-20-06

Doc #	Description	Page #
1	MTR for weighted average of chemistry – 3 ladles replaced by product analysis after PM incl MTR from Wisconsin Centrifugal	5
2	MTR for A-2 Shim revised 8/16/05	6
3	Lincoln weld metal product conformance spec Lot 30188513/78308	7
4	St Louis Test Lab dated 8/16/05 mech test results at RT & CVN @ 293°k for Lincoln lot 30188513/78308	8
5	St Louis Test Lab dated 10/5/05 CVN @ -320°F for Lincoln weld lot 30188513/78308	10
6	Westmoreland mechanical test @ -320°F dated 10/18/05 Lincoln Lot 30188513/78308	11
7	Westmoreland Tensile test report @ -320°F dated 12-28-2005	12
8	St Louis Test Lab dated 10-3-05 – incl. tensile test results @ room temp & Charpy V Notch (CVN) at 77°K & 293°K	13
9	Weld map	16
10	MQS Radiographic Inspection Report dated 10/7/05	20
11	MQS Radiographic Inspection Report dated 12/19/05	25
12	MTK Radiographic Interpretation Report dated 12/28	28
13	MTK Radiographic Shooting Sketch for A coils	29
14	MTK Radiographic Interpretation Report A-2 Shim - dated 12/16	30
15	A-2 Coil heat treat chart dated 10/6/05	32
16	A-2 Coil stress relief dated 12/23/05	34
17	A-2 Shim heat treat chart dated 06/02/05	35
18	MTK signed MTS A-1 Coil	36
19	MTK signed MTS A-1 Coil shim	47
20	CA 1308 – shim chemistry out of spec	50
21	CA 1323 – CA for sulfur & phosphorus readings - final ver. 2/26/06 - NOTE – applies to A-2 shim only	51
22	CA 1525 – Excess material left on casting	56
23	CA 1530 – Serial # not changed in core box	57
24	Final inspection report A-1 coil – dated 8/30/2005	58
25	C of C for A-1 Coil	59
26	Final Inspection report A-1 Shim	60
27	C of C for A-1 shim	61
28	EIO shipping release for A-1 Coil	62
7/20/06		



4

Carondelet Division

8600 Commercial Blvd. - Pevely, MO 63070 USA
 Phone: 636-479-4499 - Fax: 636-479-3399

Material Test Report

ENERGY INDUSTRIES OF OHIO

Purchase Order Number PPPL-FP-LTS-2
 Pattern Number MCWF-A2
 CAF Metal Designation CF8MNMnMod
 Material Spec CF8MNMnMOD

Cert Number 175410-1
 Pour Date 9/26/2005

Weighted average of 3 heats – 31032(42%),31042(22%),31045(36%) Total Weight 31570 lbs.

Date: 12/13/05

Element	Min	Actual	Max
C	0.04	0.04	0.07
MN*	2.3	2.9	2.8
SI	0.0	0.4	0.7
CR	18.0	18.3	18.5
NI	13.0	13.1	13.5
MO	2.1	2.3	2.5
P	0.0	0.034	0.035
S	0.0	0.012	0.025
N	0.24	0.25	0.28

*Over specification, see CA 1323.

PRODUCT ANALYSIS

Results of spectrometer analysis of cast on test bar after spectrometer preventive maintenance performed and at Wisconsin Centrifugal.

Element	CAF after PM			WC Analysis		
	Z1	Z2	Z3	Z1	Z2	Z3
SI	0.4	0.6	0.4	0.4	0.6	0.4
MN	2.7	2.5	2.7	2.5	2.3	2.5
CR	18.2	18.3	18.1	18.0	18.2	18.1
NI	13.0	13.1	13.0	13.2	13.3	13.2
MO	2.3	2.3	2.3	2.3	2.3	2.3
P	0.035	0.032	0.036	0.034	0.030	0.036
S	0.012	0.012	0.012	0.026	0.024	0.029

Respectfully Submitted,
 Charles A. Ruud
 Quality Assurance Manager



Carondelet Division

8600 Commercial Blvd. - Pevely, MO 63070 USA
Phone: 636-479-4499 - Fax: 636-479-3399

Material Test Report

ENERGY INDUSTRIES OF OHIO

Purchase Order Number PPPL-FP-LTS-2 Heat Number 29198 Pour Date 4/28/2005
Pattern Number SE-141-073 COIL C SHIM (-3 thru -6 Parts) Cert Number S73220-2 and
SE-141-033 COIL A SHIM (-1 thru -6 Parts) Cert Number S76220-1
CAF Metal Designation CF8MNMnMod
Material Spec CF8MNMN MOD

Revised 8/16/05

Element	Min	Actual	Max
C	0.040	0.070	0.070
CR	18.000	18.100	18.500
MN	2.300	2.970	2.800
MO	2.100	2.450	2.500
N	0.240	0.255	0.280
NI	13.000	13.120	13.500
p*	0.000	0.013	0.015
S*	0.000	0.010	0.015
SI	0.000	0.700	0.500

MN & SI previously reported on CA 1308 and were accepted.

*P & S taken from test from heat parts were poured from and analyzed by wet chemistry, ASTM E1019-03 for sulfur and Gravimetric for phosphorous.

This report covers the eleven castings poured from heat 29198. Only parts listed above however will be shipped for this order. Each casting has a unique number stamped in the part adjacent to the pattern number to differentiate the part and subsequent reporting that will be traced to the casting.

Respectfully Submitted,
Charles A. Ruud
Quality Assurance Manager

Superior Quality Engineered Metal Products

www.MetalTekInt.Com

PRODUCT CONFORMANCE REPORT



Product	LNM 4455	Size(s) mm	1,2
Class.	EN 12072-99: G 20 16 3 Mn L	Lot/Batch	3018513/78308
		Item No.	692129
Customer	EUROWELD MOORESVILLE N.C. 28117 UNITED STATES	Quantity	105,0 KG
		Customer ref.	P.O. : 05 - 46
		LSW Order No.	SD427896

Chemical analysis (%) EN10204 2.2

C	Si	Mn	P	S	Cr	Ni	Mo	Cu	N
0,01	0,5	7,3	0,015	0,001	20,3	15,4	2,9	0,1	0,19

Mechanical tests, all weld metal EN10204 2.2

Tensile testing					Impact testing		
Cond.	Temp.	Rp0.2	Rm	A5	Cond.	Temp.1	Av1
	°C	N/mm2	N/mm2	%		°C	J
AW	RT	407	623	41	AW	-196	67

Additional information EN10204 2.2

Other tests

Remarks
Impact testing (individual values): 70J - 65J - 67J.

The product identified above has been manufactured, tested and supplied in compliance with a Quality Assurance Programme that fulfils the requirements of EN 29000/ ISO 9000/BS 5750 or similar standard.
We herewith certify that the product complies with the above-mentioned standards.
Certified ISO 9001:2000.

Company	Lincoln Smitweld B.V.	Registered Office	Nieuwe Dukenburgseweg 20 6534 AD NIJMEGEN	Post address	P.O. Box 253 6500 AG Nijmegen	Issued by	P. Nagels	Telephone	31 24 352271	Function	QA Administrator	Date	22/03/2005	Cert.No.	3018513/7830	Fax:	31 24 3522200
---------	-----------------------	-------------------	--	--------------	----------------------------------	-----------	-----------	-----------	--------------	----------	------------------	------	------------	----------	--------------	------	---------------

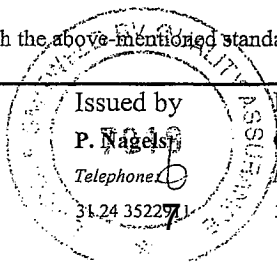

2810 Clark Avenue • St. Louis, MO 63103-2574 • (314) 531-8080 • FAX (314) 531-8085
 Chemical, Metallurgical, Mechanical, Nondestructive, Environmental Testing, Analyses and Field Service.

METALTEK INTERNATIONAL
 8600 Commercial Blvd.
 Pevely, MO 63070

August 16, 2005
 Lab No. 05P-2532
 P.O. No. 21324
 Page 1 of 2

Attention: Chuck Ruud

REPORT OF CHARPY IMPACT TEST

MATERIAL (SAMPLE ID): LNM 4455, LINCOLN LOT 3018513/78308
SPECIFICATION: ASTM A 370-03a
SPECIMEN TYPE: "A" Vee Notch
SPECIMEN SIZE: 10 mm x 10 mm
TEMPERATURE OF TEST: 293°K

BASE METAL	FOOT LBS.	LATERAL EXPANSION	% SHEAR
LNM4455-7	104	0.085	100
LNM4455-8	106	0.093	100
LNM4455-9	99	0.084	100
Average	103	0.087	100

Identification of tested specimen provided by client.

 Kari Schmitz, Director
 Materials Testing

KS/tlv

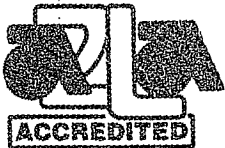

Certificate No. 0397-01
 Certificate No. 0397-02

AN OFFICIAL COPY OF TEST REPORT WILL BE PROVIDED BY THIS LABORATORY ON REQUEST.
 NOT OFFICIAL WITHOUT THE RAISED SEAL OF ST. LOUIS TESTING LABORATORIES, INC.
 SEE REVERSE FOR CONDITIONS.



2810 Clark Avenue • St. Louis, MO 63103-2574 • (314) 531-8080 • FAX (314) 531-8085
 Chemical, Metallurgical, Mechanical, Nondestructive, Environmental Testing, Analyses and Field Service.

METALTEK INTERNATIONAL
 8600 Commercial Blvd.
 Pevely, MO 63070

August 16, 2005
 Lab No. 05P-2532
 P.O. No. 21324
 Page 2 of 2

Attention: CHUCK RUUD

REPORT OF MECHANICAL TESTS

SAMPLE ID: LNM 4455, LINCOLN LOT 3018513/78308

Sample ID	Original Area Sq. Inches	Reduced Area Sq. Inches	Reduction in Area %	Yield Strength PSI	Tensile Strength PSI	Elongation (2.0" Gage Length)		Modules of Elasticity
						in.	%	
LNM4455	0.1932	0.0866	55.2	65200	95200	0.76	38.0	23.4

Round, reduced section tensiles

Yield taken at .2% offset

Tested in accordance with ASTM A 370-03a

Identification of tested specimens provided by the client.

 Karl Schmitz, Director
 Materials Testing

KS/tlv



Certificate No. 0397-01
 Certificate No. 0397-02

AN OFFICIAL COPY OF TEST REPORT WILL BE PROVIDED BY THIS LABORATORY ON REQUEST.
 NOT OFFICIAL WITHOUT THE RAISED SEAL OF ST. LOUIS TESTING LABORATORIES, INC.
 SEE REVERSE FOR CONDITIONS.



2810 Clark Avenue • St. Louis, MO 63103-2574 • (314) 531-8080 • FAX (314) 531-8085
 Chemical, Metallurgical, Mechanical, Nondestructive, Environmental Testing, Analyses and Field Service.

METALTEK INTERNATIONAL
 8600 Commercial Blvd.
 Pevely, MO 63070

October 5, 2005
 Lab No. 05P-3096
 P.O. No. 21324
 Page 1 of 1

Attention: Chuck Ruud

REPORT OF CHARPY IMPACT TEST

MATERIAL (SAMPLE ID): WELD PLATE- 3018513 / 78308
SPECIFICATION: ASTM A 370-03a
SPECIMEN TYPE: "A" Vee Notch
SPECIMEN SIZE: 10 mm x 10 mm
TEMPERATURE OF TEST: -320°F
REQUIREMENTS: minimum 35 ft / lbs.

BASE METAL	FOOT LBS.	LATERAL EXPANSION	% SHEAR
3018513/78308-1	48	0.033	50
3018513/78308-2	65	0.045	50
3018513/78308-3	48	0.033	50
Average	54	0.037	50

Identification of tested specimen provided by client.

KS/tlv

 Karl Schmitz, Director
 Materials Testing



Certificate No. 0397-01
 Certificate No. 0397-02



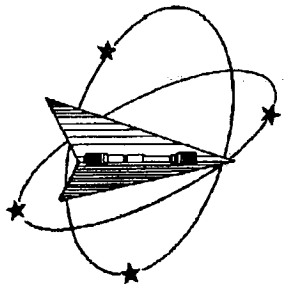

Westmoreland Mechanical Testing & Research, Inc.
 P.O. Box 388
 Westmoreland Drive
 Youngstown, Pa. 15696-0388 U.S.A.
 Telephone: 724-537-3131 Fax: 724-537-3151
 Website: www.wmtr.com
 WMT&R is a technical leader in the material testing industry.



Section 1 of 1
 WMT&R Report No. 5-35979
 Requisition No. 4972

October 18, 2005

CERTIFICATION

MetalTek International
 The Carondelet Division
 8600 Commercial Blvd.
 I-55 Industrial Park
 Pevely, MO 63070-1528

Attention: Jim Galaske

Subject: All processes, performed upon the material as received, were conducted at WMT&R, Inc. in accordance with the WMT&R Quality Assurance Manual, Rev. 9, dated 4/1/2000.
 The following tests were performed on this order: TENSILE

TENSILE RESULTS: ASTM E21-03a

SOAK TIME: 5 Minutes

SPEED OF TESTING: 0.0030 in./in./min., 0.0500 in./min./in.

MATERIAL: METALTEK CF8MNMNMOD

DISPOSITION: Report

Specimen ID	TestLog Number	Temp. °F	UTS ksi	0.2% YS ksi	Elong %	RA %	Modulus Msi	Ult. Load lbf	0.2% YLD. lbf	Orig. Dia. (in.)	Final Dia. (in.)	4D Orig GL (in.)	4D Final GL (in.)	Orig. Area (sq. in.)	Machine Number	AIUR
3018513/78308	C54936	-320	184.9	123.7	33	33	32.8	18470	12350	0.3566	0.2926	1.40	1.86	0.09987403	M9	R

AIUR: A=ACCEPTABLE, U=UNACCEPTABLE, R=REPORT

 Roy E. Starin
 Technical Services Manager / Tensile Supervisor

10-18-05
 October 18, 2005

KNOWINGLY OR WILLFULLY FALSIFYING OR CONCEALING A MATERIAL FACT ON THIS FORM OR MAKING FALSE, FICTITIOUS OR FRAUDULENT STATEMENTS OR REPRESENTATIONS HEREIN COULD CONSTITUTE A FELONY PUNISHABLE UNDER FEDERAL STATUTES. THIS CERTIFICATE OR REPORT SHALL NOT BE REPRODUCED EXCEPT IN FULL, WITHOUT THE WRITTEN APPROVAL OF WMT&R, INC.

Testing Specialists for Aerospace, Automotive, and Material Testing Fields
 Locations in Youngstown, PA U.S.A. ~ Tel. (724) 537-3131 and
 Banbury U.K. ~ Tel. +44 (0) 1295 261211

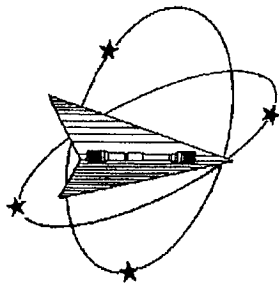

Westmoreland Mechanical Testing & Research, Inc.

P.O. Box 388

Westmoreland Drive

Youngstown, Pa. 15696-0388 U.S.A.

Telephone: 724-537-3131 Fax: 724-537-3151

Website: www.wmtr.com

WMTR is a technical leader in the material testing industry.



621-01 & 621-02



7

December 28, 2005

CERTIFICATION

Section 1 of 1

WMTR Report No. 5-40960

P.O. No. 19386

Requisition No. 7743

MetalTek International
The Carondelet Division
8600 Commercial Blvd.
I-55 Industrial Park
Pevely, MO 63070-1528

Attention: Jim Galaske

Subject: All processes performed upon the material as received were conducted at WMTR, Inc. in accordance with the WMTR Quality Assurance Manual, Rev. 9, dated 4/7/2000.

The following tests were performed on this order: TENSILE

TENSILE RESULTS: ASTM E21-05

Requirements: UTS ksi (Min 95|Max ---) 0.2% YS ksi (Min 72|Max ---) 4D Elong. % (Min 32|Max ---) Modulus Msi (Min 21|Max ---)

SOAK TIME: 5 Minutes

SPEED OF TESTING: 0.003 in./in./min., 0.05 in./min./in.

MATERIAL: Metaltek CF8MNMnMOD

DISPOSITION: Acceptable

Specimen ID	Test Log Number	Temp. °F	UTS ksi	0.2% YS ksi	Elong %	RA %	Modulus Msi	Ult Load lbf	0.2% YLD. lbf	Orig. Dia. (in.)	Final Dia. (in.)	4D Orig GL (in.)	4D Final GL (in.)	Orig. Area (sq. in.)	Machine Number	AUAR
A2-Z1	C90232	-320	164.0	99.7	59	55	24.9	15870	9645	0.3510	0.2344	1.40	2.22	0.09676184	M9	A
A2-Z2	C90233	-320	166.8	100.3	56	53	25.1	16160	9713	0.3512	0.2419	1.40	2.19	0.09687214	M9	A
A2-Z3	C90234	-320	165.2	99.8	54	51	25.9	16010	9674	0.3513	0.2462	1.40	2.16	0.09692731	M9	A

AUAR: A=ACCEPTABLE, U=UNACCEPTABLE, R=REPORT

Customer supplied requirements.

KNOWINGLY OR WILLFULLY FALSIFYING OR CONCEALING A MATERIAL FACT ON THIS FORM OR MAKING FALSE, FICTITIOUS OR FRAUDULENT STATEMENTS OR REPRESENTATIONS HEREIN COULD CONSTITUTE A FELONY PUNISHABLE UNDER FEDERAL STATUTES. THIS CERTIFICATE OR REPORT SHALL NOT BE REPRODUCED EXCEPT IN FULL, WITHOUT THE WRITTEN APPROVAL OF WMTR, INC.

Matt Wojton
Roy E. Starbuck Wojton
Technical Services Manager / Tensile Supervisor

12-28-05
December 28, 2005

Testing Specialists for Aerospace, Automotive, and Material Testing Fields
Locations in Youngstown, PA U.S.A. Tel. (724) 537-3131 and
Banbury U.K. - Tel. +44 (0) 1295 261211

2810 Clark Avenue • St. Louis, MO 63103-2574 • (314) 531-8080 • FAX (314) 531-8085
 Chemical, Metallurgical, Mechanical, Nondestructive, Environmental Testing, Analyses and Field Service.

METALTEK INTERNATIONAL
 8600 Commercial Blvd.
 Pevely, MO 63070

November 3, 2005
 Lab No. 05P-3331
 P.O. No. 21324
 Page 1 of 3

Attention: Chuck Ruud

REPORT OF CHARPY IMPACT TEST

MATERIAL (SAMPLE ID): A2- COIL, Z1, Z2, Z3
SPECIFICATION: ASTM A 370-03a
SPECIMEN TYPE: "A" Vee Notch
SPECIMEN SIZE: 10 mm x 10 mm
TEMPERATURE OF TEST: 77°K
REQUIREMENTS: 35 ft / lbs

BASE METAL	FOOT LBS.	LATERAL EXPANSION	% SHEAR
Z1-4	81	0.051	40
Z1-5	71	0.036	50
Z1-6	110	0.028	60
Average	87	0.038	50
SAMPLE ID	FOOT LBS.	LATERAL EXPANSION	% SHEAR
Z2-4	75	0.031	40
Z2-5	74	0.054	50
Z2-6	78	0.029	30
Average	76	0.038	40
SAMPLE ID	FOOT LBS.	LATERAL EXPANSION	% SHEAR
Z3-4	82	0.048	40
Z3-5	73	0.046	50
Z3-6	67	0.031	40
Average	74	0.042	43

Identification of tested specimen provided by client.

 Karl Schmitz, Director
 Materials Testing



Certificate No. 0397-01
 Certificate No. 0397-02

AN OFFICIAL COPY OF TEST REPORT WILL BE PROVIDED BY THIS LABORATORY ON REQUEST.
 NOT OFFICIAL WITHOUT THE RAISED SEAL OF ST. LOUIS TESTING LABORATORIES, INC.
 SEE REVERSE FOR CONDITIONS.



2810 Clark Avenue • St. Louis, MO 63103-2574 • (314) 531-8080 • FAX (314) 531-8085
 Chemical, Metallurgical, Mechanical, Nondestructive, Environmental Testing, Analyses and Field Service.

METALTEK INTERNATIONAL
 8600 Commercial Blvd.
 Pevely, MO 63070

November 3, 2005
 Lab No. 05P-3331
 P.O. No. 21324
 Page 2 of 3

Attention: Chuck Ruud

REPORT OF CHARPY IMPACT TEST

MATERIAL (SAMPLE ID): A2- COIL, Z1, Z2, Z3
SPECIFICATION: ASTM A 370-03a
SPECIMEN TYPE: "A" Vee Notch
SPECIMEN SIZE: 10 mm x 10 mm
TEMPERATURE OF TEST: + 293°
REQUIREMENTS: *Ch 50* 60 ft / lbs

BASE METAL	FOOT LBS.	LATERAL EXPANSION	% SHEAR
Z1-4	180	0.111	90
Z1-5	158	0.076	80
Z1-6	174	0.096	80
Average	171	0.094	83
SAMPLE ID	FOOT LBS.	LATERAL EXPANSION	% SHEAR
Z2-4	160	0.091	90
Z2-5	204	0.066	90
Z2-6	170	0.092	90
Average	178	0.083	90
SAMPLE ID	FOOT LBS.	LATERAL EXPANSION	% SHEAR
Z3-4	140	0.096	90
Z3-5	140	0.076	90
Z3-6	148	0.056	90
Average	143	0.076	90

Identification of tested specimen provided by client.

[Signature]
 Karl Schmitz, Director
 Materials Testing



Certificate No. 0397-01
 Certificate No. 0397-02

AN OFFICIAL COPY OF TEST REPORT WILL BE PROVIDED BY THIS LABORATORY ON REQUEST.
 NOT OFFICIAL WITHOUT THE RAISED SEAL OF ST. LOUIS TESTING LABORATORIES, INC.
 SEE REVERSE FOR CONDITIONS.



2810 Clark Avenue • St. Louis, MO 63103-2574 • (314) 531-8080 • FAX (314) 531-8085
 Chemical, Metallurgical, Mechanical, Nondestructive, Environmental Testing, Analyses and Field Service.

METALTEK INTERNATIONAL
 8600 Commercial Blvd.
 Pevely, MO 63070

November 3, 2005
 Lab No. 05P-3331
 P.O. No. 21324
 Page 3 of 3

Attention: Chuck Ruud

REPORT OF MECHANICAL TESTS

SAMPLE ID: A-2 COIL, Z1, Z2, Z3

Sample ID	Original Area Sq. Inches	Reduced Area Sq. Inches	Reduction in Area %	Modulus of Elasticity	Yield Strength PSI	Tensile Strength PSI	Elongation (2.0" Gage Length)	
							in.	%
Z1	0.1948	0.1007	48.3	22.5 Msi	44400	83200	1.13	56.5
Z2	0.1924	0.0755	60.8	21.7 Msi	42100	83700	1.14	57.0
Z3	0.1987	0.0774	61.0	22.3 Msi	43300	84300	1.10	55.0

Round, reduced section tensiles
 Yield taken at .2% offset
 Tested in accordance with ASTM A 370-03a
Identification of tested specimens provided by the client.

KS/tlv

 Karl Schmitz, Director
 Materials Testing



Certificate No. 0397-01
 Certificate No. 0397-02

AN OFFICIAL COPY OF TEST REPORT WILL BE PROVIDED BY THIS LABORATORY ON REQUEST.
 NOT OFFICIAL WITHOUT THE RAISED SEAL OF ST. LOUIS TESTING LABORATORIES, INC.
 SEE REVERSE FOR CONDITIONS.



A-2 Coil Weld Map – Metal Tek

Map of all major welds exceeding 20% of wall, over 1 inch or over 10² inches

Defect Number	Drawing View	Length (inches)	Width (inches)	Depth (inches)
1	Right	4 ³ / ₄	2	1 ¹ / ₈
2	Right	2 ¹ / ₂	2 ⁷ / ₈	1
3	Right	16	3	Thru
4	Right	23	2 ¹ / ₂	2
5	Right	6 ³ / ₄	2 ³ / ₄	2 ¹ / ₂
6	Right	5 ³ / ₄	3 ¹ / ₂	1 ¹ / ₂
7	Right	11	1 ¹ / ₈	¹ / ₄
8	Front	2 ³ / ₄	3	2
9	Front	4 ³ / ₄	2 ³ / ₄	2
10	Front	2 ¹ / ₂	2 ¹ / ₂	1
11	Front	13	3	2
12	Front	8	3	2
13	Front	9 ¹ / ₄	2 ¹ / ₂	Thru
14	Front	6	2 ¹ / ₂	1
15	Front	7 ³ / ₄	6 ¹ / ₂	¹ / ₂
16	Front	11	4 ¹ / ₂	1
17	Right	4 ¹ / ₂	4	1
18	Right	4 ¹ / ₄	2 ¹ / ₂	Thru
19	Right	3 ⁷ / ₈	3 ³ / ₄	1 ¹ / ₈
20	Back	4	3 ³ / ₄	1 ¹ / ₈
21	Back	29	4	Thru
22	Back	7	1 ³ / ₄	1
23	Back	6	3 ¹ / ₄	1 ¹ / ₂
24	Back	13 ³ / ₄	1 ¹ / ₂	1
25	Back	13 ¹ / ₂	1 ¹ / ₂	³ / ₄
26	Back	10	1 ³ / ₄	1 ¹ / ₂
27	Back	10 ¹ / ₂	1	³ / ₄
28	Back	5	3	1 ¹ / ₄

A-2 Coil Weld Map – Metal Tek

Map of all major welds exceeding 20% of wall, over 1 inch or over 10² inches

A-2
Front

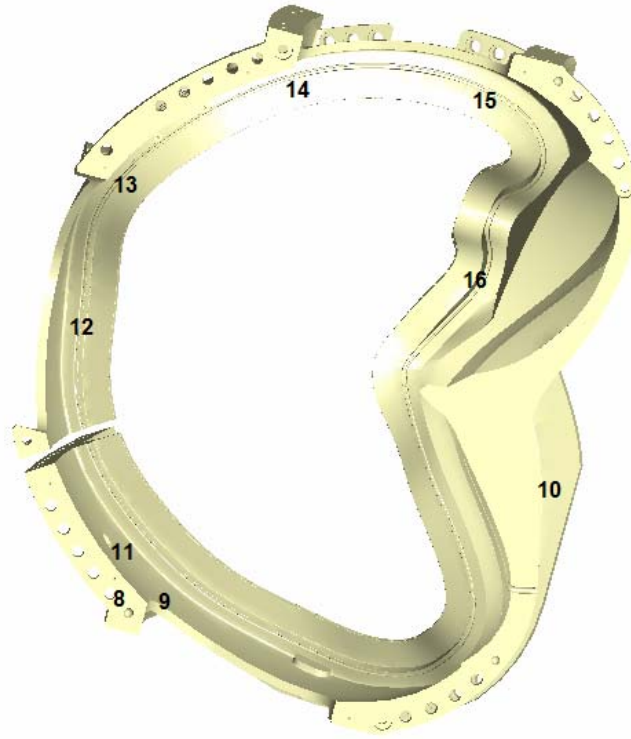

A-2 Coil Weld Map – Metal Tek

Map of all major welds exceeding 20% of wall, over 1 inch or over 10² inches

A-2
Back

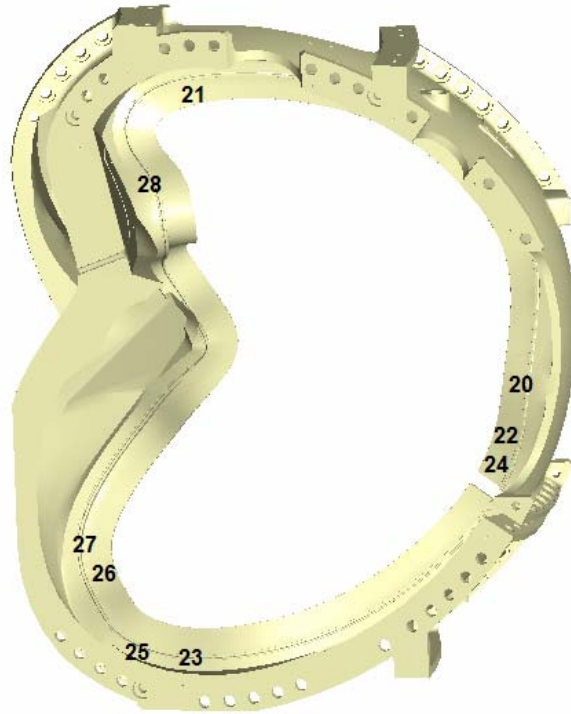

A-2 Coil Weld Map – Metal Tek

Map of all major welds exceeding 20% of wall, over 1 inch or over 10² inches

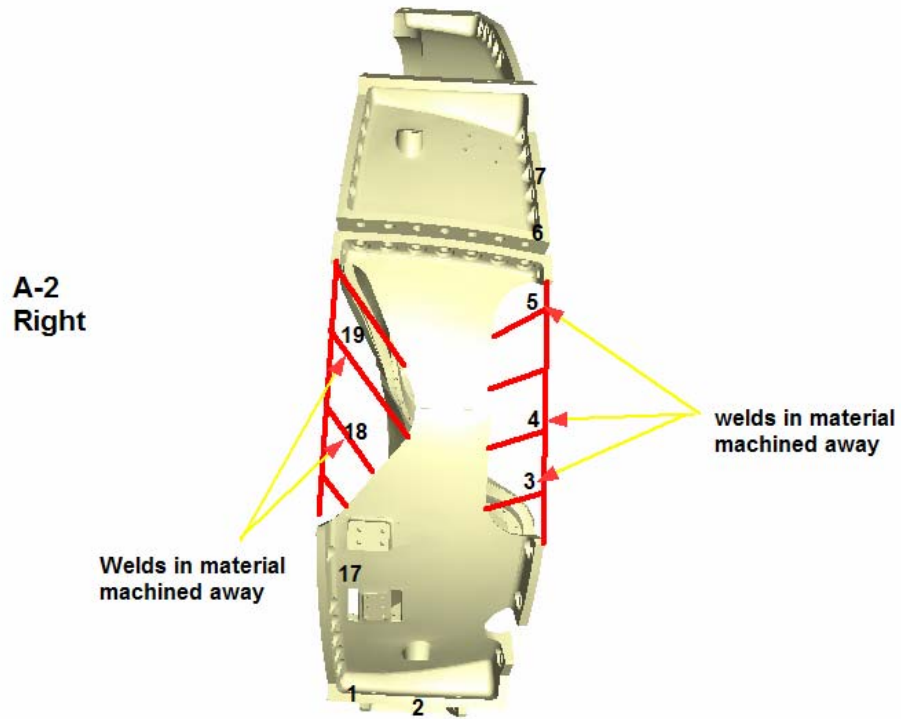

TEAM COOPERHEAT-MQS, INC.

CERTIFIED RADIOGRAPHIC INSPECTION REPORT

FORM 6061-RT- 002 Rev.2

5512 W. State St. Milwaukee, WI 53208 Tel:(414)771-3060 Fax:(414)771-9481 (800)818-6403 www.cooperheat-mqs.com

CUSTOMER		DATE	WORK ORDER NO.
NAME METAL TEK INTERNATIONAL		10/07/2005	361-02661
ADDRESS 8600 COMMERCIAL BLVD		P.O. NUMBER 22409	XRAY X
CITY PEVELY STATE MO ZIP 63070			GAMMA
PROCEDURE SPECIFICATION ASTM E94-93	ACCEPTANCE CRITERIA MSS-SP-54-1999	SHEET _____ OF _____	

PART NUMBER	Serial No	View	No Apparent Indications		Incomplete Penetration		Shrinkage		Film Artifacts		REMARKS
			Acceptable	Rejected	Dross or Porosity	Lack of Fusion Gas Cracks	Hot Tears	Under cut Surface			
MCWFA-2	2	1-2	✓							✓	
		2-3		R					R		
Z103990		3-4	✓							✓	
HT# M175410		4-5	✓								
CO 40851		5-6	✓				2-3				
		6-7	✓				2-3				
		7-8		R			4				
		8-9	✓				2				
		9-10	✓								
		10-11	✓				1-2				
		11-12	✓		2						
		12-13		R					R		
		13-14	✓		2			1-2			
		15	✓								
		16-17	✓								
		17-18	✓								
		18-19	✓								
		19-20	✓								
		20-21	✓								
		21-22		R					R	✓	
		22-23	✓							✓	
		23-24		R					R		
		24-25		R					R		
		25-26	✓				2				
		26-27	✓								

NO. ACCEPTED	Φ	NO. REJECTED	1	MQS TECH. NO.	12970	SHT.	REV.
COMMENTS				CUST. RSS NO.		SHT.	REV.
				REVIEWER	<i>John Petroske</i>		
				CERTIFIED NDT LEVEL (RT)			
				John Petroske RT II Exp. 01/08			

TEAM COOPERHEAT-MQS, INC.

CERTIFIED RADIOGRAPHIC INSPECTION REPORT

FORM 6061-RT- 002 Rev.2

5512 W. State St. Milwaukee, WI 53208 Tel:(414)771-3060 Fax:(414)771-9481 (800)818-6403 www.cooperheat-mqs.com

CUSTOMER		DATE	WORK ORDER NO.
NAME METAL TEK INTERNATIONAL		10/07/2005	361-02661
ADDRESS 8600 COMMERCIAL BLVD		P.O. NUMBER	XRAY X
CITY PEVELY STATE MO ZIP 63070		22409	GAMMA
PROCEDURE SPECIFICATION	ACCEPTANCE CRITERIA	SHEET ____ OF ____	
ASTM E94-93	MSS-SP-54-1999		

PART NUMBER	Serial No	View	No Apparent Indications		Incomplete Penetration		Shrinkage		Film Artifacts		REMARKS
			Acceptable	Rejected	Dross or Porosity	Lack of Fusion Gas Cracks	Hot Under Tears cut	Surface			
MCWFA-2	1	27-28	✓	R			R	R			
		28-29	✓							✓	
Z103990		29-1	✓								
HT# M175410		30-31	✓							✓	
CO 40851		31-32		R				R			
		32-33	✓								
		33-34	✓							✓	
		34-35	✓		1						
		35-36		R	5			R			
		37-38		R				R			
		38-39	✓		1						
		39-40	✓								
		41-42	✓							✓	
		43-44		R	4						
		44-45	✓				1				
		45-46	✓								
		46-47	✓							✓	
		47-48	✓								
		48-49	✓								
		50-51	✓							✓	
		51-52	✓								✓
		52-53		R				R			
		54-55	✓				1				
		55-56		R				4	R		
		57-58	✓								

NO. ACCEPTED	Φ	NO. REJECTED	1	MQS TECH. NO.	12970	SHT.	REV.
COMMENTS				CUST. RSS NO.		SHT.	REV.
				REVIEWER	<i>John Petroske</i>		
				CERTIFIED NDT LEVEL (RT)			
				John Petroske RT II Exp. 01/08			

TEAM COOPERHEAT-MQS, INC.

CERTIFIED RADIOGRAPHIC INSPECTION REPORT

FORM 6061-RT- 002 Rev.2

5512 W. State St. Milwaukee, WI 53208 Tel:(414)771-3060 Fax:(414)771-9481 (800)818-6403 www.cooperheat-mqs.com

CUSTOMER		DATE	WORK ORDER NO.
NAME METAL TEK INTERNATIONAL		10/07/2005	361-02661
ADDRESS 8600 COMMERCIAL BLVD		P.O. NUMBER	XRAY X
CITY PEVELY STATE MO ZIP 63070		22409	GAMMA
PROCEDURE SPECIFICATION ASTM E94-93	ACCEPTANCE CRITERIA MSS-SP-54-1999	SHEET ____ OF ____	

PART NUMBER	Serial No	View	No Apparent Indications		Incomplete Penetration		Shrinkage		Film Artifacts		REMARKS
			Acceptable	Rejected	Dross or Porosity	Lack of Fusion Gas Cracks	Hot Tears	Under Surface			
MCWFA-2	1	58-58A-59	✓					1			
		59-60	✓		1						
Z103990		60-61	✓					2			
HT# M175410		61-62	✓					2			
CO 40851		62-63		R					R		
		63-64		R					R		
		63-64	✓							✓	
		64-65	✓							✓	
		65-65A-66	✓							✓	
		66-67		R				R		✓	
		67-68		R				4			
		68-69		R			2	4			
		69-70	✓								
		70-71	✓					1			
		71-72		R				4			
		72-73		R			4				
		73-74	✓								
		74-75	✓				2				
		75-76	✓								
		76-77		R	3-4		4				
		77-78	✓								
		78-79	✓								
		79-80	✓								
		80-81	✓							✓	
		81-82	✓		2						

NO. ACCEPTED	NO. REJECTED	MQS TECH. NO.	SHT.	REV.
4	1	12970		
COMMENTS		CUST. RSS NO.	SHT.	REV.
		REVIEWER <i>John Petroske</i>		
		CERTIFIED NDT LEVEL (RT)		
		John Petroske RT II Exp. 01/08		

TEAM COOPERHEAT-MQS, INC.

CERTIFIED RADIOGRAPHIC INSPECTION REPORT

FORM 6061-RT- 002 Rev.2

5512 W. State St. Milwaukee, WI 53208 Tel:(414)771-3060 Fax:(414)771-9481 (800)818-6403 www.cooperheat-mqs.com

CUSTOMER		DATE	WORK ORDER NO.
NAME METAL TEK INTERNATIONAL		10/07/2005	361-02661
ADDRESS 8600 COMMERCIAL BLVD		P.O. NUMBER 22409	XRAY X
CITY PEVELY STATE MO ZIP 63070			GAMMA
PROCEDURE SPECIFICATION ASTM E94-93	ACCEPTANCE CRITERIA MSS-SP-54-1999	SHEET ____ OF ____	

PART NUMBER	Serial No	View	No Apparent Indications		Dross		Incomplete Penetration		Shrinkage		Film Artifacts		REMARKS
			Acceptable	Rejection	Inclusion	Porosity	Lack of Fusion	Gas Cracks	Hot Tears	Under cut	Surface		
MCWFA-2	1	82-83	✓			2							
		84-85	✓									✓	
Z103990		85-86	✓									✓	
HT# M175410		86-87	✓										
CO 40851		87-88A	✓										
		88-89	✓									✓	
		89-90	✓									✓	
		90-91			R				4			✓	
		92-93	✓									✓	
		94-95			R				4			✓	
		95-96			R				4-5			✓	
		96-97			R				5			✓	
		97-98	✓						2-3			✓	
		98-99			R				4			✓	
		99-100			R				4			✓	
		100-101	✓						3			✓	
		102-103			R				4			✓	
		103-104	✓									3	
		104-105	✓									3	
		106-107	✓										
		107-108	✓										
		108-109			R	5						2	
		109-110	✓									2	
		111-112	✓										
		112-113	✓									1	

NO. ACCEPTED	NO. REJECTED	MQS TECH. NO.	SHT.	REV.
φ	1	12970		
COMMENTS		CUST. RSS NO.	SHT.	REV.
		REVIEWER		
		CERTIFIED NDT LEVEL (RT)		
		John Petroske RT II Exp. 01/08		

TEAM COOPERHEAT-MQS, INC.

CERTIFIED RADIOGRAPHIC INSPECTION REPORT

FORM 6061-RT- 002 Rev.2

5512 W. State St. Milwaukee, WI 53208 Tel:(414)771-3060 Fax:(414)771-9481 (800)818-6403 www.cooperheat-mqs.com

CUSTOMER		DATE	WORK ORDER NO.
NAME METAL TEK INTERNATIONAL		10/07/2005	361-02661
ADDRESS 8600 COMMERCIAL BLVD		P.O. NUMBER 22409	XRAY X
CITY PEVELY STATE MO ZIP 63070			GAMMA
PROCEDURE SPECIFICATION ASTM E94-93	ACCEPTANCE CRITERIA MSS-SP-54-1999	SHEET ____ OF ____	

PART NUMBER	Serial No	View	No Apparent Indications		Dross		Incomplete Penetration		Shrinkage		Film Artifacts		REMARKS
			Acceptable	Rejected	Included	or Porosity	Lack of Fusion	Gas Cracks	Hot Tears	Under cut	Surface		
MCWFA-2	1	113-114	✓							1			
		115-116	✓										
Z103990		116-117	✓										
HT# M175410		118-119	✓							1			
CO 40851		119-120	✓						2				
		121-122	✓										
		122-123	✓									✓	
		123-124	✓			2							
		124-125		R							R		
		125-126		R							R		
		126-127	✓										
		127-128	✓								1		
		128-129		R							R		
		130-131	✓										
		131-132	✓						2				
		V133	✓										
		V134	✓										

NO. ACCEPTED	0	NO. REJECTED	1	MQS TECH. NO.	12970	SHT.	REV.
COMMENTS				CUST. RSS NO.		SHT.	REV.
				REVIEWER	<i>John Petroske</i>		
				CERTIFIED NDT LEVEL (RT)			
				John Petroske RT II Exp. 01/08			

TEAM COOPERHEAT-MQS, INC.

CERTIFIED RADIOGRAPHIC INSPECTION REPORT

FORM 6061-RT- 002 Rev.2

5512 W. State St. Milwaukee, WI 53208 Tel:(414)771-3060 Fax:(414)771-9481 (800)818-6403 www.cooperheat-mqs.com

CUSTOMER		DATE	WORK ORDER NO.
NAME METAL TEK INTERNATIONAL		12/19/2005	361-02763
ADDRESS 8600 COMMERCIAL BLVD		P.O. NUMBER Chuck Rudd	XRAY X
CITY PEVELY STATE MO ZIP 63070			GAMMA
PROCEDURE SPECIFICATION ASTM E94-93	ACCEPTANCE CRITERIA MSS-SP-54-1999	SHEET ____ OF ____	

PART NUMBER	Serial No	View	No Apparent Indications		Dross or Porosity		Incomplete Penetration		Shrinkage		Film Artifacts		REMARKS
			Acceptable	Rejected	Included	Excluded	Lack of Fusion	Gas Cracks	Hot Tears	Undercut	Surface		
MCWFA-2		2-3	✓									✓	
	(R1)	7-8	✓						2				
Z103990		12-13	✓						2				
HT# M175410		21-22	✓										
CO 40851		23-24	✓						1				
		24-25	✓									✓	
		31-32	✓										
		35-36	✓										
		37-38	✓										
		43-44	✓										*
		52-53	✓										
		55-56	✓										
		62-63	✓									✓	
		67A-63A	✓										
		66-67	✓									✓	
		67-68	✓									✓	
		68-69	✓									✓	
		71-72	✓						1-2	1		✓	
		72-73	✓									✓	
		76-77	✓										
		90-91	✓						1			✓	
		94-95	✓										
		95-96	✓										
		96-97	✓										
		99-100	✓						2				

NO. ACCEPTED	1	NO. REJECTED	0	MQS TECH. NO.	12970	SHT.	REV.
COMMENTS	* Extra shot Taken for densities.			CUST. RSS NO.		SHT.	REV.
				REVIEWER	<i>John Petroske</i>		
				CERTIFIED NDT LEVEL (RT)	John Petroske RT II Exp. 01/08		

TEAM COOPERHEAT-MQS, INC.

CERTIFIED RADIOGRAPHIC INSPECTION REPORT

FORM 6061-RT- 002 Rev.2

5512 W. State St. Milwaukee, WI 53208 Tel:(414)771-3060 Fax:(414)771-9481 (800)818-6403 www.cooperheat-mqs.com

CUSTOMER		DATE	WORK ORDER NO.
NAME METAL TEK INTERNATIONAL		12/19/2005	361-02763
ADDRESS 8600 COMMERCIAL BLVD		P.O. NUMBER	XRAY X
CITY PEVELY STATE MO ZIP 63070		Chuck Rudd	GAMMA
PROCEDURE SPECIFICATION ASTM E94-93	ACCEPTANCE CRITERIA MSS-SP-54-1999	SHEET	OF

PART NUMBER	Serial No	View	No Apparent Indications		Dross		Incomplete Penetration		Shrinkage		.Film Artifacts		REMARKS
			Acceptable	Rejected	Included	or Porosity	Lack of Fusion	Gas Cracks	Hot Tears	Under cut	Surface		
MCWFA-2		74-75	✓										
		92-93	✓										
Z103990													
HT# M175410	*	25-26	✓						2				
CO 40851	*	26-27	✓										

NO. ACCEPTED 1	NO. REJECTED 0	MQS TECH. NO. 12970	SHT.	REV.	
COMMENTS * Did No Reshot 25-26, 26-27. These views originally had Large Chill Blocks in these views. They have since been cut out. Thus the called out pens have no where on part to be placed.		CUST. RSS NO.	SHT.	REV.	
		REVIEWER <i>John Petroske</i> CERTIFIED NDT LEVEL (RT) John Petroske RT II Exp. 01/08			

MetalTek

INTERNATIONAL

RADIOGRAPHIC INTERPRETATION REPORT

CUSTOMER <i>Energy Industries of Ohio</i>	PURCHASE ORDER NUMBER <i>PPPL-FP-LTS-2</i>	DATE <i>12-28-05</i>	CONTROL NO. <i>40851</i>	PAGE <i>1 of 1</i>											
PART NO. <i>MCW FA-2</i>	SPECIFICATION <i>E186/E280</i>	CLASS <i>see spec</i>	TOTAL PIECES <i>1</i>	PIECES ACCEPTED <i>1</i>											
RADIOGRAPHED BY: <i>Kelley/Midgett</i>		INTERPRETED BY: <i>Kelley/Midgett</i>		ASNT LEVEL <i>II</i>											
FILM TYPE <i>29/59/80</i>	MATERIAL <i>CF8M/MN Mod</i>	ISOTOPE <i>IRIDIUM 192 ✓ COBALT 60</i>		CODE <i>ASTM E94 ✓ ASME MIL-STD-453</i>											
<i>M175410</i>	<table style="width: 100%; border-collapse: collapse;"> <tr> <td style="width: 25%; text-align: center;">VIEW</td> <td style="width: 25%; text-align: center;">PEN E</td> <td style="width: 25%; text-align: center;">ACCEPT</td> <td style="width: 25%; text-align: center;">REJECT</td> </tr> </table>	VIEW	PEN E	ACCEPT	REJECT	<table style="width: 100%; border-collapse: collapse;"> <tr> <td style="width: 25%; text-align: center;">R E J E C T</td> <td style="width: 25%; text-align: center;">S H R I N K</td> <td style="width: 25%; text-align: center;">I N C L U S I O N</td> <td style="width: 25%; text-align: center;">P O R O S I T Y</td> </tr> </table>	R E J E C T	S H R I N K	I N C L U S I O N	P O R O S I T Y	<table style="width: 100%; border-collapse: collapse;"> <tr> <td style="width: 25%; text-align: center;">L I N E A R</td> <td style="width: 25%; text-align: center;">S U R F A C E</td> <td style="width: 25%; text-align: center;">L O F / L O P</td> <td style="width: 25%; text-align: center;">COMMENTS</td> </tr> </table>	L I N E A R	S U R F A C E	L O F / L O P	COMMENTS
VIEW	PEN E	ACCEPT	REJECT												
R E J E C T	S H R I N K	I N C L U S I O N	P O R O S I T Y												
L I N E A R	S U R F A C E	L O F / L O P	COMMENTS												
<i>R1</i>	<i>27-28</i>	<i>50/80</i>	<i>100</i>	<i>/</i>											

RADIOGRAPHIC STANDARD SHOOTING SKETCH

Customer <u>Energy Industries of OHIO</u>	Pattern Number <u>MCWFA-2</u>
Material <u>CF8MNMN mod</u>	Traceability Number
Film Manufacturer <u>Fuji</u>	Source Number <u>82ci IR. 192</u>
IQI LEVEL <u>2-2T</u> From CQP 401 <input checked="" type="checkbox"/> Other (Specify, E.G. 2-4T, 2-1T) <u>N/A</u>	

Exposures (views)	<u>27-28</u>																			
Thickness (IN.)	<u>2 3/4 - 7"</u>																			
S/F Distance (IN.)	<u>18"</u>																			
Penetrameter	<u>50 80 100</u>																			
Time (MIN.)	<u>2hr</u>																			
Focal Spot (IN.)	<u>.1</u>																			
Film Size (IN.)	<u>14X17</u>																			
Screen Size (Pb)																				
Front/Back	<u>.01</u>																			
S.W.E./D.W.E.	<u>SWE</u>																			
S.W.V./D.W.V.	<u>SWV</u>																			
Film Type	<u>2959 80X2</u>																			
Acceptance Standard	<u>E180 E280</u>																			
Severity Level	<u>SP54</u>																			

Shooting Sketch (Use Additional Pages as Needed)

See original Technique Drawing.

Technique Prepared By: Doug Midgett Level: II Date: 12-28-05
 Technique Approved By: _____ Level: _____ Date: _____

MetalTek INTERNATIONAL

RADIOGRAPHIC INTERPRETATION REPORT

CUSTOMER Energy Industries of Ohio			PURCHASE ORDER NUMBER PPL-FP-LTS-2				DATE 12-16-05		CONTROL NO. 40851			PAGE 1 of 1	
PART NO. SE-141-033-2			SPECIFICATION E126			CLASS III			TOTAL PIECES 1		PIECES ACCEPTED 1		
RADIOGRAPHED BY: Kelley			INTERPRETED BY: Kelley				ASNT LEVEL II						
FILM TYPE	MATERIAL			ISOTOPE						CODE			COMMENTS
80	CF8M N/M/M			REJECT	SHRINK	INCLUSION	POROSITY	LINER	SURFACE	LOF/LOP			
MS 76220 RT-2	A	50	/									Film Scratch	
	B		/										
	C		/			1			/				
	D	4	/										

Welcome to

MetalTek

INTERNATIONAL

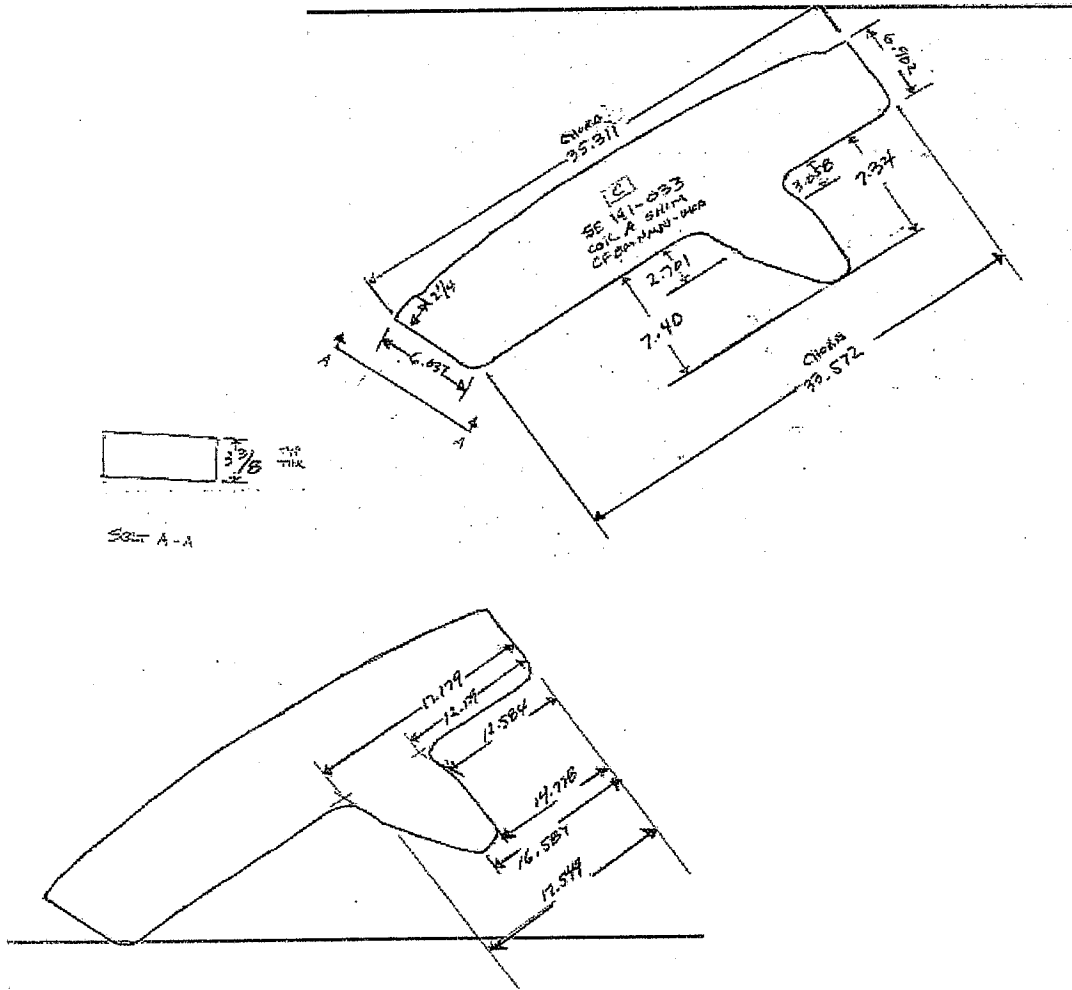

SE-141-033-2

MS76220-1

12/28/05

JJOHNSON

EIO

MCWF-A2 C012

F-5

175210-1

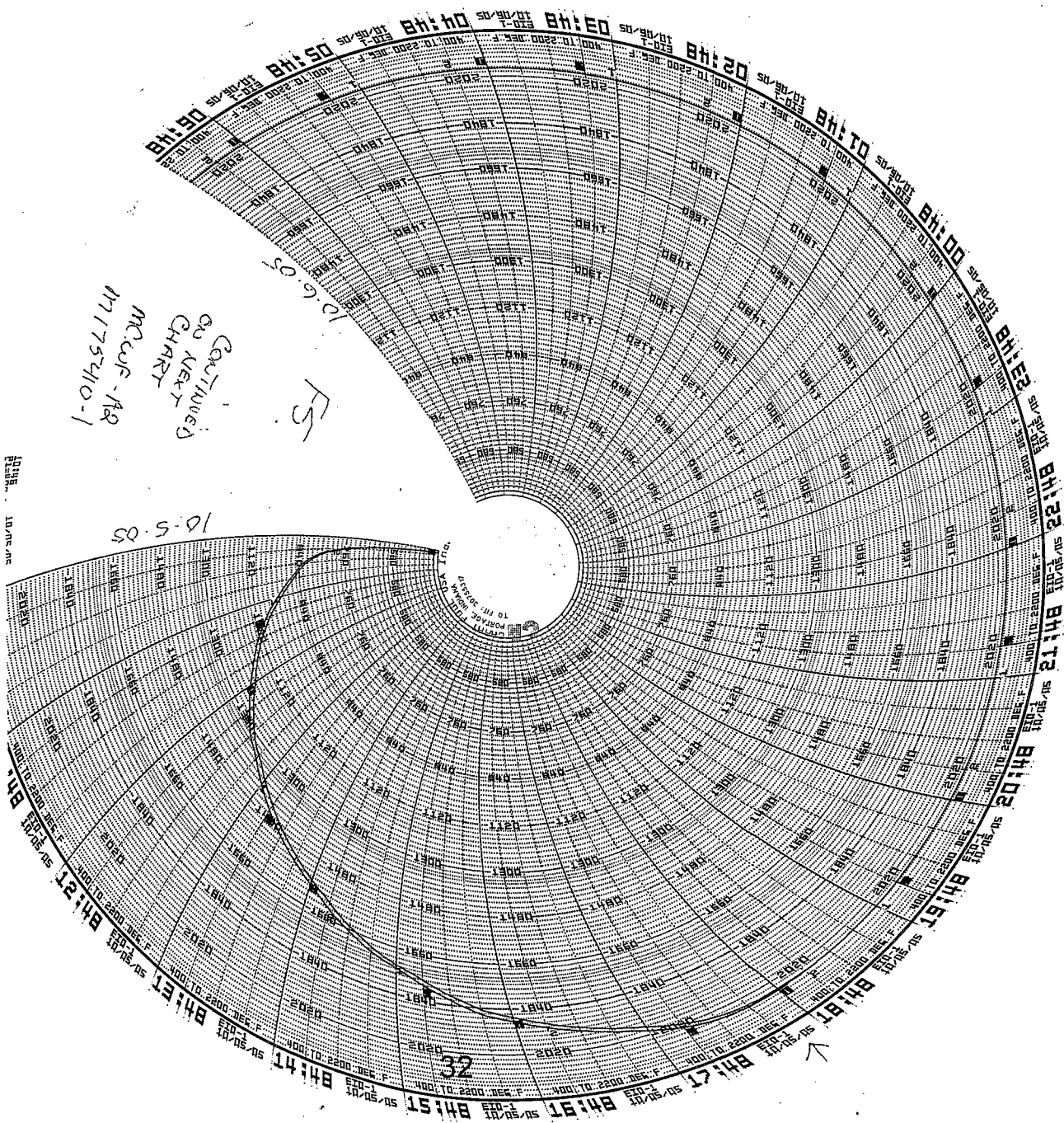

CONTINUED
ON NEXT
CHART
MCWF-A2
175210-1

10.6.05
FS

10.5.05

10.5.05

32

EIO

MCWF-A2

F-5

175410-1

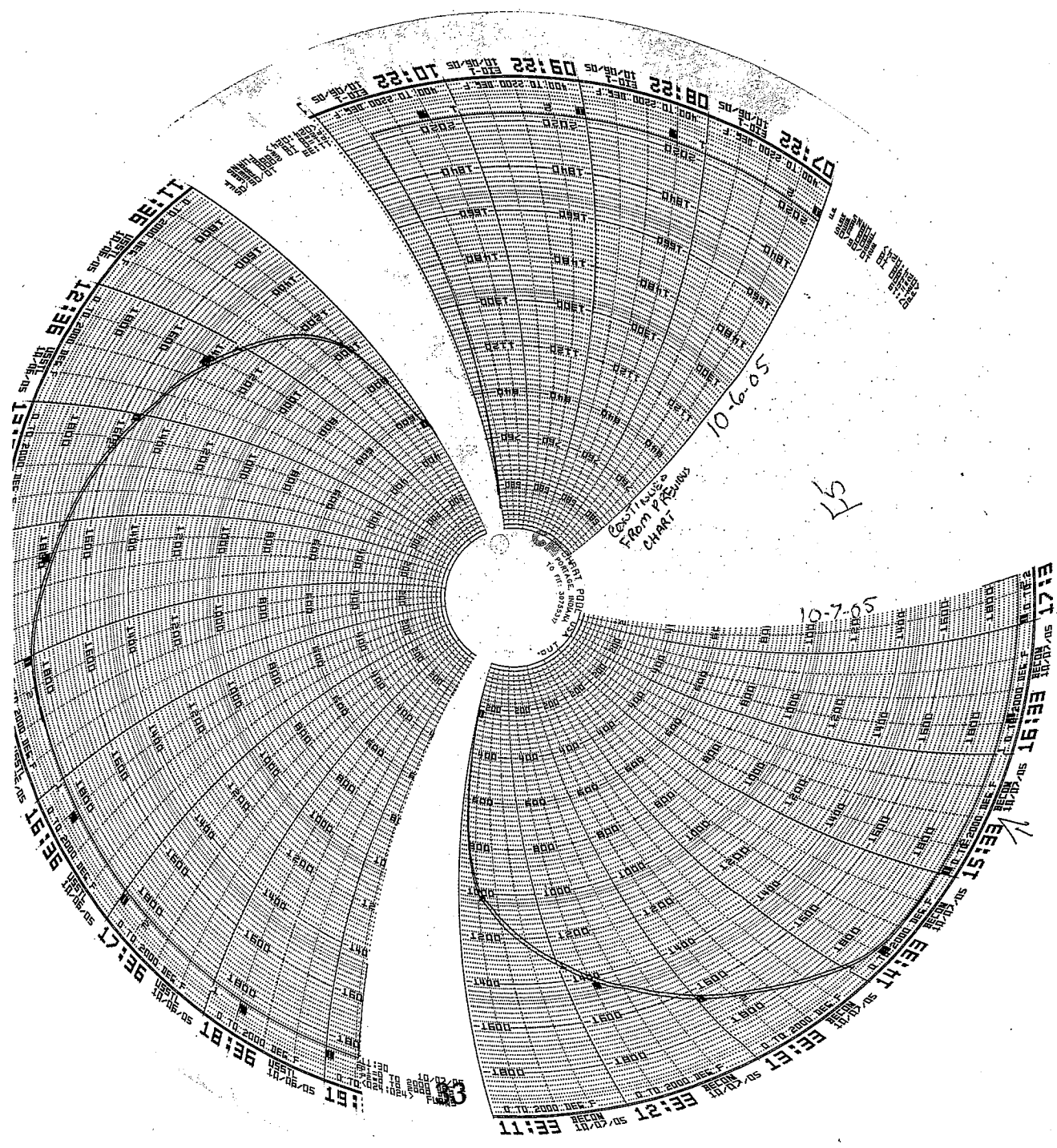

E I O

MCWF A-2 COLL

F-5

175410-1

MCWF-A2
POST WELD H.T.
M175410-1

F5

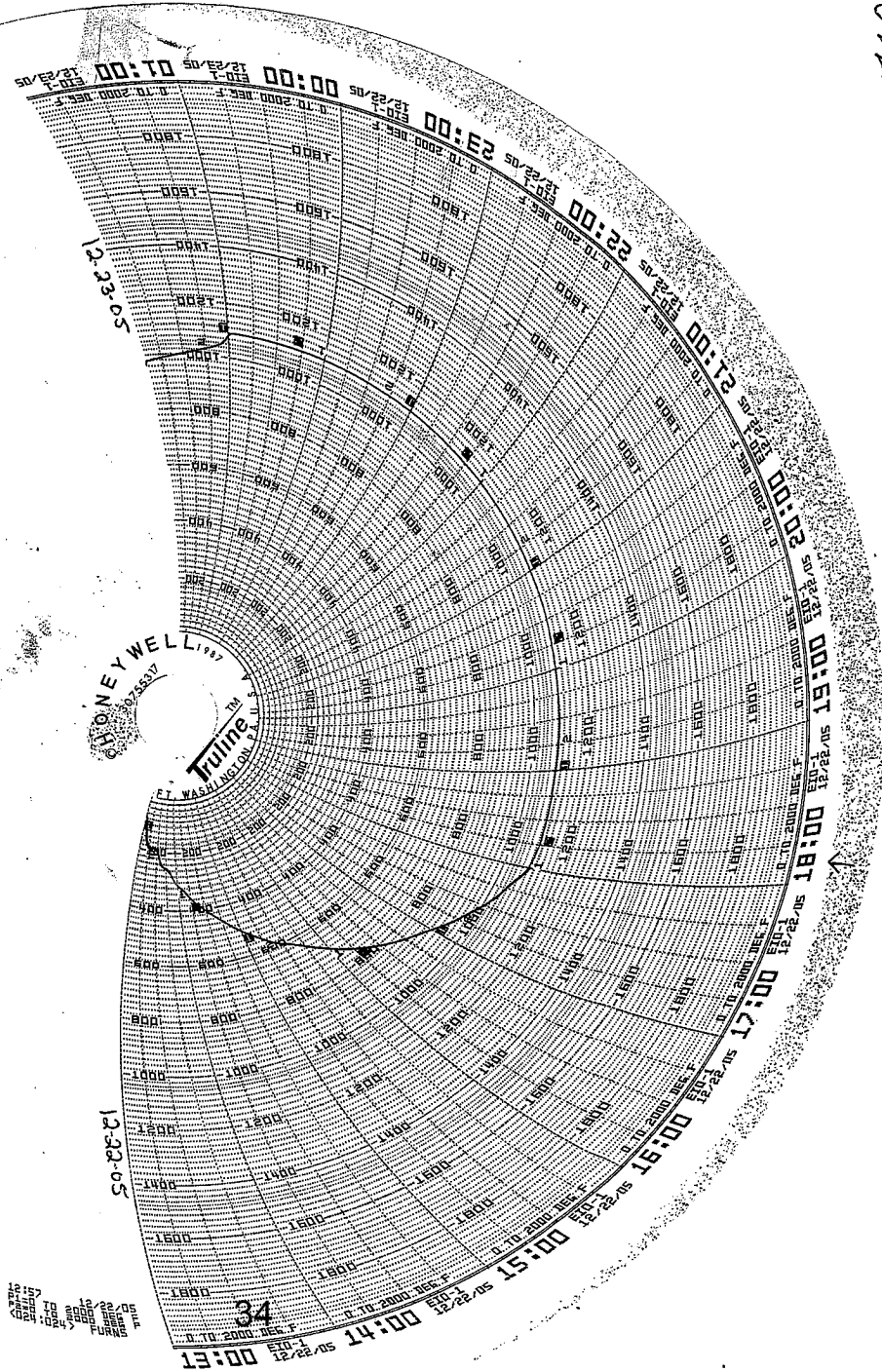

34
 13:00
 14:00
 15:00
 16:00
 17:00
 18:00
 19:00
 20:00
 21:00
 22:00
 23:00
 24:00
 25:00
 26:00
 27:00
 28:00
 29:00
 30:00
 31:00
 32:00
 33:00
 34:00
 35:00
 36:00
 37:00
 38:00
 39:00
 40:00
 41:00
 42:00
 43:00
 44:00
 45:00
 46:00
 47:00
 48:00
 49:00
 50:00
 51:00
 52:00
 53:00
 54:00
 55:00
 56:00
 57:00
 58:00
 59:00

A+C Shims CTR

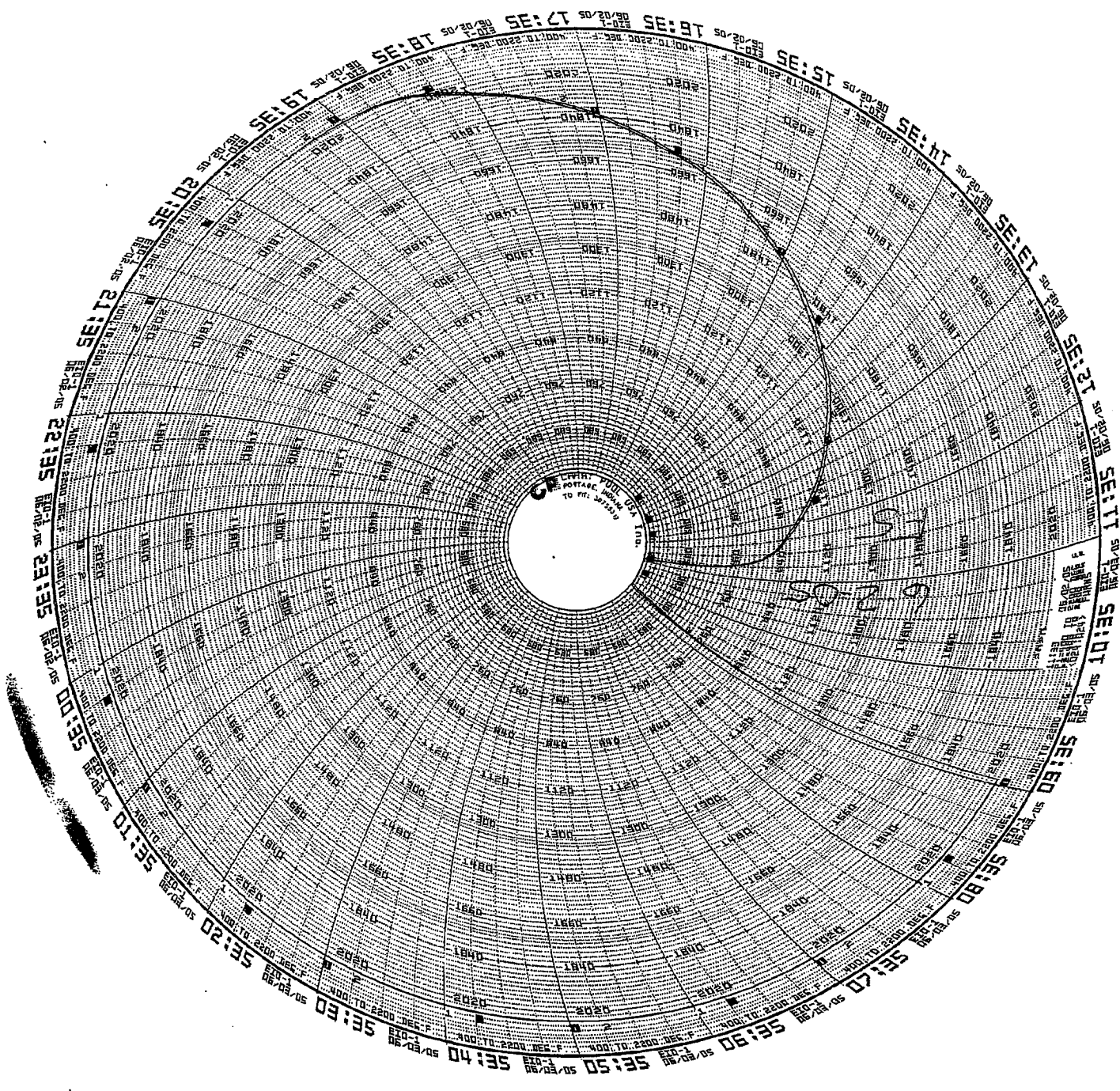

Energy Industries of Ohio
Manufacturing and Test Sequence (MTS) A 2 Coil

1 OF 11 CO# 40851 Dated 3-9-05 Revision: Rev 9 Dated Issued:9/26/05

OPER. #	STATION	DESCRIPTION OF PROCESS	Name	Date
10	QUALITY RELEASE	REVIEW AND APPROVE MTS. RECEIVED APPROVAL FROM EIO ON xxxx FROM _Pete D._ SIGNED QUALITY MANAGER	<i>CDN</i>	<i>9/24/05</i>
15	PATTERN NPAT SOP 0100REV2	APPLY APPROPRIATE PART NUMBER, SERIAL NUMBER, AND FOUNDRY MARK, TO THE PATTERN. CAST ON TEST BARS AND CAST ON BLOCKS (extra 3"x3"x1" specimens) REQUIRED, ID AS TO COIL NUMBER AND ZONE LOCATION.	<i>AS</i>	<i>9/24/05</i>
20	COREMAKE CORE SOP 0100 REV 6 CALIBRATION PER CORE SOP 0200R4/0300R6	MAKE CORES IN SAND MIXTURES AS DESCRIBED BY METALTEK ENGINEERING AND VERIFIED IN MODELING TRIALS. METALTEK CORE SOP 0100 REV 6) CORE WASH WITH ZIRCONIUM CORE WASH. (CALIBRATION OF EQUIPMENT REQUIRED PER CORE SOP 0200,R4 / 0300,R6) VERIFY COUNT AND INSPECT.	<i>SS</i>	<i>9/26-05</i>
30	MOLD MOLD SOP 0400 REV 8 CALIBRATION PER MOLD SOP 0900 REV 5 PREPARATION PER MOLD SOP 1100R2/1200R2/1300R1 SAND TESTING PER MOLD SOP 1400R2/1500R3/1600R2	MOLD PER WORK INSTRUCTIONS IN MAPICS ROUTING AND SOPS REFERENCED. ENGINEER OF RECORD - ROGER BROMAN, CONSULT ON MOLD-RELATED CONCERNS. MOLD MATERIALS REQUIRED PER MAPICS BOM. NOTIFY ENGINEER OF ANY SUBSTITUTIONS. <i>Change Fire crackers</i>	<i>SS</i>	<i>9-26-05</i>
40	POUR MELT SOP 0100R5 MELT SOP 0700R2 MELT SOP 0600R2	METAL MUST BE AOD REFINED OR AOD INGOT. VIRGIN METAL ADDITIONS ALLOWED. RECORD POURING TEMPERATURE: <i>2750</i> CASTING POURED AT: <i>2750</i> DATE: <i>9/27/05</i> HEAT #'s: <i>31041, 31042, 31043, 31044, 31045</i> ELAPSED POUR TIME <i>1 min 10 sec</i> KEEL BLOCKS POURED: <i>NA</i> Sample from ladle to be analyzed for final chemical analysis and reported on material certifications. Sample Taken by: <i>gn</i> Analyzed: <i>A.A.</i> Date: <i>9-27-05</i>	<i>SR</i>	<i>9/27/05</i>
50	MELT SOP 0800R2	SHAKEOUT	<i>CA</i>	<i>10/1</i>
60	ARC RISE SOP 0100R1	REMOVE RISERS AS DIRECTED BY SUPERVISOR.	<i>MW</i>	<i>10-11-05</i>

**Energy Industries of Ohio
Manufacturing and Test Sequence (MTS) A 2 Coil**

2 OF 11 CO# 40851 Dated 3-9-05 Revision: Rev 9 Dated Issued:9/26/05

70	HEAT TREAT HEAT SOP 0103R5	SOLUTION ANNEAL. MAKE SURE TO BLOCK ALL FLANGES OF FORM AND RACETRACK TO MINIMIZE CREEP DISTORTION. Soak Temp: 2050F, Soak Time: At least 7 hours, Quench Type: Air Cool MAKE SURE TEST MATERIAL IS PLACED IN THE CORRECT ZONE.	DLS	10/5/05
80	PHYSICAL TESTING	OBTAIN TEST SPECIMENS AND SUBMIT FOR PHYSICAL TESTING. REPORT RESULTS AS PART OF STEP 530. DCMA IS TO WITNESS CHARPY TESTING AT LAB.	WH	10/6
NOTE		THE ORDER OF CLEANING PROCESSES MAY BE ALTERED DUE TO CAPACITY CONSTRAINTS. HOLD POINTS AND COMPLIANCE WILL NOT BE COMPROMISED. EIO WILL BE ADVISED OF ALL CHANGES THAT MAY RESULT IN A REQUEST FOR DEVIATION FROM REQUIREMENTS.		
90	GRIND GSA SOP 0100R3	SWING GRIND TO REMOVE RISER REMAINS AND FLASH IF REQUIRED.	<i>[Signature]</i>	10/11/05
100	GRIND GCHI SOP 0100R2	CHIP AND HAD GRIND SURFACE OF PART AS REQUIRED FOR CONTOUR.	DWP T.V	P.N
110	SAND BLAST BLAS SOP 0100R6	SANDBLAST (REMOVE ALL BLAST MATERIAL FROM CASTING) SANDBLASTING WILL BE DONE USING RECYCLED SHARP ANGULAR AGGREGATE.	P.N	CHT, Pre X-ray blast 11-02-05
NOTICE	WITNESS NOTIFICATION	PROVIDE NOTICE TO EIO AND DCMA AT LEAST FIVE DAYS IN ADVANCE OF X-RAY. EIO NOTIFIED ON <u>10/19</u> DCMA NOTIFIED ON <u>10/19/05</u>	Q ENG OR QA MGR	<i>[Signature]</i>
120	X-RAY AT MQS MQS PROCEDURE 20.H.010 REV 0	X-RAY PER TECHNIQUE # 12726 USE CALIBRATED DENSITOMETER FOR DENSITY VERIFICATION. WHEN MARKING USE BLACK MARKERS. ATTACH TECHNIQUE, READER SHEET FOR ALL RADIOGRAPHS. MUST INDICATE RADIOGRAPHER AND ASNT CERTIFICATION LEVEL ON READER SHEET.	RT - LEVEL II DWM	11-11-05
130	X-RAY CQP 401 REV 5	X-RAY INTERPRETATION. ACCEPTANCE MSS SP 54. ATTACH TECHNIQUE, READER SHEET FOR ALL RADIOGRAPHS. MUST INDICATE RADIOGRAPHER AND ASNT CERTIFICATION LEVEL ON READER SHEET. IF OK CHECK HERE <input type="checkbox"/> AND SEND TO STEP 160. REJECTED CHECK HERE <input checked="" type="checkbox"/> MARK UP DEFECTS AND SEND THE CASTING TO STEP 140.	RT - LEVEL II	DWM 11-11-05
140	WELD SOP 0100 REV 7	EXCAVATE ANY DEFECTS FOUND DURING 100% RT INSPECTION.	TLS 11-14-05	
150	GRIND GCHI SOP 0100R2	CHIP AND HAND GRIND EXCAVATION AS REQUIRED.	WH	11/14

**Energy Industries of Ohio
Manufacturing and Test Sequence (MTS) A 2 Coil**

3 OF 11 CO# 40851 Dated 3-9-05 Revision: Rev 9 Dated Issued:9/26/05

160	INTERIM VISUAL INSPECTION CQP-500 REV 4	VISUALLY INSPECT 100% of COMPONENT ACCORDING TO ASTM A802 LEVEL 3 IN NON MACHINED AREAS AND LEVEL 2 IN MACHINED AREAS. IF OK CHECK HERE _____ IF REJECTED CHECK HERE <input checked="" type="checkbox"/> . MARK AND REPAIR AT STEP 190.	VT - LEVEL II KA	11/15
170	INTERIM 100% L.P. CQP 0300 REV 10	L.P. 100% OF COMPONENT. ACCEPTANCE PER ASTM A903. ACCEPTANCE CRITERIA- LEVEL 1 FOR HIGH STRESSED AREAS, LEVEL 2 FOR ALL OTHER AREAS. SEE LP DRAWING. IF OK CHECK HERE _____ GO TO 190. IF REJECTED CHECK HERE <input checked="" type="checkbox"/>	LP - LEVEL II TRS	11/15
180	WELD SOP 0100 REV 7	EXCAVATE ANY DEFECTS FOUND DURING 100% VISUAL AND LP INSPECTION.	TRS	11/17/05
190	GRIND GCHI SOP 0100R2	CHIP AND HAND GRIND EXCAVATION OR VISUAL DEFECTS AS REQUIRED.	CA	11-20-05
200	L.P. EXCAVATION CQP-300 REV 10	L.P. ALL EXCAVATIONS PRIOR TO WELDING TO ENSURE REMOVAL OF DEFECT. ACCEPTANCE PER A903. ACCEPTANCE CRITERIA-LEVEL 1 FOR HIGH STRESSED AREAS, LEVEL 2 FOR ALL OTHER AREAS. SEE LP DRAWING. IF OK CHECK HERE <input checked="" type="checkbox"/> IF REJECTED SEND BACK TO STEP 190	LP - LEVEL II TRS	11-25
210	SAND BLAST BLAS SOP 0100R6	SANDBLAST (REMOVE ALL BLAST MATERIAL FROM CASTING) SANDBLASTING WILL BE DONE USING RECYCLED SHARP ANGULAR AGGREGATE.	AB	
220	WELD MAP	MAP ALL MAJOR WELDS WITH DIGITAL PHOTO/MAPS INDICATING LOCATION. SERIALIZE DEFECTS ON CASTING, USE SCALE IN PHOTOS AND DOCUMENT SIZE. THIS IS TO BE PERFORMED BY SUPERVISOR, INSPECTION LEAD MAN OR THEIR DESIGNEE, FILE WITH QA. USE YELLOW MARKER. SUBMIT MAP WITHIN 24 HOURS OF START OF WELDING. MUST INDICATE ON MAP ALL MAJOR WELDS, DEFINED AS GREATER THAN 20% OF THE WALL OR 1 INCH WHICHEVER IS LESS OR 10 SQUARE INCHES APPROXIMATLY 3.3"X3.3".	JB	11-17 11-18
NOTICE	WITNESS NOTIFICATION	PROVIDE NOTICE TO EIO AND DCMA AT LEAST FIVE DAYS IN ADVANCE OF WELD STEP. EIO NOTIFIED ON <u>11/19</u> DCMA NOTIFIED ON <u>11/19</u>	Q ENG OR QA MGR	CAK
230	QA APPROVAL HOLD POINT	QA TO APPROVE ELECTRODE PRIOR TO USE. PROCEDURE USED: <u>15-GMAW-CF8MNMN/MOD</u> LIST ALL MATERIAL/LOTS USED: <u>3018513/78308</u> QUALITY ENG. Name: <u>11/19</u> Date: <u>CAK</u>		
240	WELD SOP 0100 REV 7	WELD REPAIR DEFECTS AS MARKED. FOR WELDS <2" - WPS 10-SMAW-CF8MNMN MOD REV 1(Flat) or 25 SMAW-CF8MNMN MOD.	RBD	11/20

Energy Industries of Ohio

Manufacturing and Test Sequence (MTS) A 2 Coil

4 OF 11 CO# 40851 Dated 3-9-05 Revision: Rev 9 Dated Issued:9/26/05

		REV 0 (Vertical) FOR WELDS <8" - WPS 15-GMAW-CF8MNMN MOD REV 2					
250	GRIND GCHI SOP 0100R2	HAND GRIND WELDS.	RBD				
260	L.P. WELD CQP 0300 REV 10	L.P. WELD REPAIRS ACCEPTANCE PER ASTM A903. ACCEPTANCE CRITERIA-LEVEL 1 FOR HIGH STRESSED AREAS, LEVEL 2 FOR ALL OTHER AREAS. SEE LP DRAWING. IF OK CHECK HERE <input checked="" type="checkbox"/> WASH AND SEND TO STEP 280. IF REJECTED CHECK HERE _____	LP - LEVEL II CC 12/9/05				
270	REPEAT	REPEAT STEPS S180 TO S250AS REQUIRED TILL CLEAR THROUGH VISUAL INSPECTION & PENETRANT INSPECTION. IF OK CHECK HERE _____ AND PROCEED TO STEP 280.	N/A				
280	REPEAT STEPS	SUPPLEMENTAL REPAIR STEPS	1 ST	2ND	3 RD	4 TH	5TH
S180	WELD SOP 0100 REV 7	EXCAVATE ANY DEFECTS FOUND DURING RADIOGRAPHY.					
S190	GRIND GCHI SOP 0100R2	CHIP AND HAND GRIND EXCAVATION OR VISUAL DEFECTS AS REQUIRED.					
S200	L.P. EXCAVATION CQP-300 REV 10	L.P. ALL EXCAVATIONS PRIOR TO WELDING TO ENSURE REMOVAL OF DEFECT. ACCEPTANCE PER A903. ACCEPTANCE CRITERIA-LEVEL 1 FOR HIGH STRESSED AREAS, LEVEL 2 FOR ALL OTHER AREAS. SEE LP DRAWING.	LP - LEVEL II				
S210	WELD MAP	MAP ALL MAJOR WELDS WITH DIGITAL PHOTO/MAPS INDICATING LOCATION. SERIALIZE DEFECTS ON CASTING, USE SCALE IN PHOTOS AND DOCUMENT SIZE. THIS IS TO BE PERFORMED BY SUPERVISOR, INSPECTION LEAD MAN OR THEIR DESIGNEE, FILE WITH QA. USE YELLOW MARKER. MUST INDICATE ON MAP ALL MAJOR WELDS, DEFINED AS GREATER THAN 20% OF THE WALL OR 1 INCH WHICHEVER IS LESS OR 10 SQUARE INCHES APPROXIMATLY 3.3"X3.3". SUBMIT MAP WITHIN 24 HOURS OF START OF WELDING.					
NOTICE	WITNESS NOTIFICATION	PROVIDE NOTICE TO EIO AND DCMA AT LEAST FIVE DAYS IN ADVANCE OF WELD STEP. EIO NOTIFIED ON _____ DCMA NOTIFIED ON _____	Q ENG OR QA MGR				
S220	QA APPROVAL HOLD POINT	QA TO APPROVE ELECTRODE PRIOR TO USE. PROCEDURE USED: _____, _____, _____ MATERIAL /LOT USED : _____, _____, _____ QUALITY ENG. Name: _____ Date: _____					
S230	WELD SOP 0100 REV 7	WELD REPAIR DEFECTS AS MARKED. FOR WELDS <2" - WPS 10-SMAW-CF8MNMN MOD REV 1(Flat) or 25 SMAW-CF8MNMN MOD REV 0 (Vertical)					

**Energy Industries of Ohio
Manufacturing and Test Sequence (MTS) A 2 Coil**

5 OF 11 CO# 40851 Dated 3-9-05 Revision: Rev 9 Dated Issued:9/26/05

		FOR WELDS <8" - WPS 15-GMAW-CF8MNMN MOD REV 2							
S240	GRIND GCHI SOP 0100R2	HAND GRIND WELDS.							
S250	L.P. WELD CQP 0300 REV 10	L.P. WELD REPAIRS ACCEPTANCE PER ASTM A903. ACCEPTANCE CRITERIA-LEVEL 1 FOR HIGH STRESSED AREAS, LEVEL 2 FOR ALL OTHER AREAS. SEE LP DRAWING. IF OK CHECK HERE _____ WASH AND SEND TO STEP 280. IF REJECTED CHECK HERE _____ AND RETURN TO STEP S180.	LP - LEVEL II	OK REJ	OK REJ	OK REJ	OK REJ		
	REPEAT	REPEAT STEPS S180 TO S250 AS REQUIRED TILL CLEAR THROUGH VISUAL INSPECTION & PENETRANT INSPECTION.	QA ENG.						
280	TEST MAG PERM SOP MAG PERM 100, REV 1	TEST MAG PERMEABILITY REPAIR AREAS TEST AT LEAST EVERY 2 INCH SQUARE OF WELD. ACCEPTANCE 1.02. IF OK CHECK HERE <input checked="" type="checkbox"/> AND GO TO STEP 300. IF REJECTED CHECK HERE _____.				CA	12/9		
290	GRIND GCHI SOP 0100R2	GRIND AREAS OF NON COMPLIANCE AND RETURN TO STEP 280. REPEAT UNTIL COMPLIANCE IS ACHIEVED.				NA			
300	X-RAY (NOTE)	IF RADIO GRAPHED AREAS ARE GREATER THAN FOUR TO FIVE INCHES THE CASTING WILL BE SENT TO MQS. SEND TO MQS CHECK HERE <input checked="" type="checkbox"/> . RADIOGRAPH AT CAF CHECK HERE _____.			QA ENGINE ER		RBK 12/16/05		
310 A	MQS X-RAY DEFECTS REPAIRED BY WELDING	X-RAY PER TECHNIQUE # 12726 USE CALIBRATED DENSITOMETER FOR DENSITY VERIFICATION. ALL RT REJECTS, INCLUDING SURFACE DEFECTS WILL BE VERIFIED BY RT. ATTACH TECHNIQUE, READER SHEET FOR ALL RADIOGRAPHS. MUST INDICATE RADIOGRAPHER AND ASNT CERTIFICATION LEVEL ON READER SHEET.			LEVEL II		RBK 12/19/05		
310 B	CAF X-RAY DEFECTS REPAIRED BY WELDING CQP 401 REV 5	X-RAY PER TECHNIQUE # 12726 USE CALIBRATED DENSITOMETER FOR DENSITY VERIFICATION. ALL RT REJECTS, INCLUDING SURFACE DEFECTS WILL BE VERIFIED BY RT. ATTACH TECHNIQUE, READER SHEET FOR ALL RADIOGRAPHS. MUST INDICATE RADIOGRAPHER AND ASNT CERTIFICATION LEVEL ON READER SHEET.			RT - LEVEL II		NA		
320	X-RAY CQP 401 REV 5	X-RAY INTERPRETATION. ACCEPTANCE MSS SP 54. ATTACH TECHNIQUE, READER SHEET FOR ALL RADIOGRAPHS. MUST INDICATE RADIOGRAPHER AND ASNT CERTIFICATION LEVEL ON READER SHEET. IF OK CHECK HERE <input checked="" type="checkbox"/> AND SEND TO STEP 340. REJECTED CHECK HERE _____ MARK UP DEFECTS AND SEND THE CASTING TO STEP S321.			RT - LEVEL II		RBK 12/21/05		
	REPEAT STEPS	SUPPLEMENTAL REPAIR STEPS	1 ST	2 ND	3 RD	4 TH	5 TH		

Energy Industries of Ohio
Manufacturing and Test Sequence (MTS) A 2 Coil

6 OF 11 **CO# 40851 Dated 3-9-05 Revision: Rev 9 Dated Issued:9/26/05**

S321	WELD SOP 0100 REV 7	EXCAVATE ANY DEFECTS FOUND DURING RADIOGRAPHY.						NA
S322	L.P. EXCAVATION CQP-300 REV 10	L.P. ALL EXCAVATIONS PRIOR TO WELDING TO ENSURE REMOVAL OF DEFECT. ACCEPTANCE PER A903. ACCEPTANCE CRITERIA-LEVEL 1 FOR HIGH STRESSED AREAS, LEVEL 2 FOR ALL OTHER AREAS. SEE LP DRAWING.	LP - LEVEL II					
S323	WELD MAP	MAP ALL MAJOR WELDS WITH DIGITAL PHOTO/MAPS INDICATING LOCATION. SERIALIZE DEFECTS ON CASTING, USE SCALE IN PHOTOS AND DOCUMENT SIZE. THIS IS TO BE PERFORMED BY SUPERVISOR, INSPECTION LEAD MAN OR THEIR DESIGNEE, FILE WITH QA. USE YELLOW MARKER. MUST INDICATE ON MAP ALL MAJOR WELDS, DEFINED AS GREATER THAN 20% OF THE WALL OR 1 INCH WHICHEVER IS LESS OR 10 SQUARE INCHES APPROXIMATELY 3.3"X3.3". SUBMIT MAP WITHIN 24 HOURS OF START OF WELDING. SUBMIT MAP WITHIN 24 HOURS OF START OF WELDING.						
NOTICE	WITNESS NOTIFICATION	PROVIDE NOTICE TO EIO AND DCMA AT LEAST FIVE DAYS IN ADVANCE OF WELD STEP. EIO NOTIFIED ON _____ DCMA NOTIFIED ON _____	Q ENG OR QA MGR					
S324	QA APPROVAL HOLD POINT	QA TO APPROVE ELECTRODE PRIOR TO USE. PROCEDURE USED: _____, MATERIAL /LOT USED : _____, QUALITY ENG. Name: _____ Date: _____						
S325	WELD SOP 0100 REV 7	WELD REPAIR DEFECTS AS MARKED. FOR WELDS <2" - WPS 10-SMAW-CF8MNMN MOD REV 1(Flat) or 25 SMAW-CF8MNMN MOD REV 0 (Vertical) FOR WELDS <8" - WPS 15-GMAW-CF8MNMN MOD REV 2						
S326	GRIND GCHI SOP 0100R2	HAND GRIND WELDS.						
S327	L.P. WELD CQP 0300 REV 10	L.P. WELD REPAIRS ACCEPTANCE PER ASTM A903. ACCEPTANCE CRITERIA-LEVEL 1 FOR HIGH STRESSED AREAS, LEVEL 2 FOR ALL OTHER AREAS. SEE LP DRAWING. IF OK CHECK HERE _____ WASH AND SEND TO STEP S328. IF REJECTED CHECK HERE _____ AND RETURN TO STEP S321.	LP - LEVEL II	OK	OK	OK	OK	OK
				REJ	REJ	REJ	REJ	REJ
S 328 A	MQS X-RAY DEFECTS REPAIRED BY WELDING	X-RAY PER TECHNIQUE # 12726 USE CALIBRATED DENSITOMETER FOR DENSITY VERIFICATION. ALL RT REJECTS, INCLUDING SURFACE DEFECTS WILL BE VERIFIED BY RT. ATTACH TECHNIQUE, READER SHEET FOR ALL RADIOGRAPHS. MUST INDICATE RADIOGRAPHER AND ASNT CERTIFICATION LEVEL ON READER SHEET.	RT- LEVE L II					

Energy Industries of Ohio
Manufacturing and Test Sequence (MTS) A 2 Coil

7 OF 11 CO# 40851 Dated 3-9-05 Revision: Rev 9 Dated Issued:9/26/05

S 328 B	CAF X-RAY DEFECTS REPAIRED BY WELDING CQP 401 REV 5	X-RAY PER TECHNIQUE # 12726 USE CALIBRATED DENSITOMETER FOR DENSITY VERIFICATION. ALL RT REJECTS, INCLUDING SURFACE DEFECTS WILL BE VERIFIED BY RT. ATTACH TECHNIQUE, READER SHEET FOR ALL RADIOGRAPHS. MUST INDICATE RADIOGRAPHER AND ASNT CERTIFICATION LEVEL ON READER SHEET.	RT - LEVE L II						
S 329	X-RAY CQP 401 REV 5	X-RAY INTERPRETATION. ACCEPTANCE MSS SP 54. ATTACH TECHNIQUE, READER SHEET FOR ALL RADIOGRAPHS. MUST INDICATE RADIOGRAPHER AND ASNT CERTIFICATION LEVEL ON READER SHEET. IF OK CHECK HERE _____ AND SEND TO STEP 340. REJECTED CHECK HERE _____ MARK UP DEFECTS AND SEND THE CASTING TO STEP S321.	RT - LEVE L II						
	REPEAT	REPEAT STEPS S321 TO S329 AS REQUIRED TILL CLEAR THROUGH VISUAL, PENETRANT AND RT INSPECTION.	QA ENG.						
340	SAND BLAST BLAS SOP 0100R6	SANDBLAST (REMOVE ALL BLAST MATERIAL FROM CASTING) SANDBLASTING WILL BE DONE USING RECYCLED SHARP ANGULAR AGGREGATE.						DS	
NOTICE	WITNESS NOTIFICATION	PROVIDE NOTICE TO EIO AND DCMA AT LEAST FIVE DAYS IN ADVANCE OF VISUAL AND LP STEPS. EIO NOTIFIED ON <u>12/16</u> DCMA NOTIFIED ON <u>12/16</u>						Q ENG OR QA MGR	OK
350	FINAL VISUAL INSPECTION CQP-500 REV 4	VISUALLY INSPECT 100% of COMPONENT ACCORDING TO ASTM A802 LEVEL 3 IN NON MACHINED AREAS AND LEVEL 2 IN MACHINED AREAS. IF OK CHECK HERE <u>✓</u> . SEND TO STEP 453. IF REJECTED CHECK HERE _____. MARK AND REPAIR. INITIAL WHEN COMPLETE. MUST BE PERFORMED BY LEVEL II in VT.						VT - LEVEL II KA	12/21
360	FINAL L.P. CQP 0300 REV 10	FINAL L.P. 100% OF COMPONENT. ACCEPTANCE PER ASTM A903. ACCEPTANCE CRITERIA-LEVEL 1 FOR HIGH STRESSED AREAS, LEVEL 2 FOR ALL OTHER AREAS. SEE LP DRAWING. IF OK CHECK HERE <u>✓</u> WASH AND SEND TO STEP 453. IF REJECTED CHECK HERE _____						LP - LEVEL II JS	12/21
380	WELD SOP 0100 REV 7	EXCAVATE ANY DEFECTS FOUND DURING FINAL PENETRANT INSPECTION.							NA
385	GRIND GCHI SOP 0100R2	CHIP AND HAD GRIND EXCAVATION AS REQUIRED.							NA

N/A
↓

Energy Industries of Ohio
Manufacturing and Test Sequence (MTS) A 2 Coil

8 OF 11 CO# 40851 Dated 3-9-05 Revision: Rev 9 Dated Issued:9/26/05

390	L.P. EXCAVATION CQP-300 REV 10	L.P. ALL EXCAVATIONS PRIOR TO WELDING TO ENSURE REMOVAL OF DEFECT. ACCEPTANCE PER A903. IF OK CHECK HERE _____ IF REJECTED SEND BACK TO STEP 385.	LP - LEVEL II	
400	WELD MAP	MAP ALL MAJOR WELDS WITH DIGITAL PHOTO/MAPS INDICATING LOCATION. SERIALIZE DEFECTS ON CASTING, USE SCALE IN PHOTOS AND DOCUMENT SIZE. THIS IS TO BE PERFORMED BY SUPERVISOR, INSPECTION LEAD MAN OR THEIR DESIGNEE, FILE WITH QA. USE YELLOW MARKER. SEND MAPS WITHIN 24 HOURS OF WELDING. MUST INDICATE ON MAP ALL MAJOR WELDS, DEFINED AS GREATER THAN 20% OF THE WALL OR 1 INCH WHICHEVER IS LESS OR 10 SQUARE INCHES APPROXIMATLY 3.3"X3.3".		
420	QA APPROVAL HOLD POINT	QA TO APPROVE ELECTRODE PRIOR TO USE. PROCEDURE USED: _____ MATERIAL/LOT USED: _____ QUALITY ENG. Name: _____ Date: _____		
430	WELD SOP 0100 REV 7	WELD REPAIR DEFECTS AS MARKED. FOR WELDS <2" - WPS 10-SMAW-CF8MNMN MOD REV 1(Flat) or 25 SMAW-CF8MNMN MOD REV 0 (Vertical) FOR WELDS <8" - WPS 15-GMAW-CF8MNMN MOD REV 2		
440	GRIND GCHI SOP 0100 REV 2	HAND GRIND WELDS.		
450	L.P. WELDS CQP 0300 REV 10	L.P. WELD REPAIRS ACCEPTANCE PER ASTM A903. IF OK CHECK HERE _____ WASH AND SEND TO STEP 453. IF REJECTED CHECK HERE _____ AND RETURN TO STEP 440.	LP - LEVEL II	
	REPEAT	REPEAT STEPS 350 TO 450 AS REQUIRED TILL WELDS CLEAR FINAL LIQUID PENETRANT INSPECTION. DOCUMENT REWORK ON A SUPPLEMENTAL MTS	QA ENG.	
451	TEST MAG PERM SOP MAG PERM 100, REV 1	TEST MAG PERMEABILITY REPAIR AREAS. RECORD ON WELD MAP LIST. TEST AT LEAST EVERY 2" SQUARE OF WELD. ACCEPTANCE 1.02. IF OK CHECK HERE _____ AND GO TO STEP 430. IF REJECTED CHECK HERE _____.		
452	GRIND GCHI SOP 0100R2	GRIND AREAS OF NON COMPLIANCE AND RETURN TO STEP 451. REPEAT UNTIL COMPLIANCE IS ACHIEVED.		
NOTICE	WITNESS NOTIFICATION	PROVIDE NOTICE TO EIO AND DCMA AT LEAST FIVE DAYS IN ADVANCE OF LAYOUT. EIO NOTIFIED ON <u>12/16</u> DCMA NOTIFIED ON <u>12/16</u> APPROVAL RECEIVED ON <u>NA</u>	Q ENG OR QA MGR	<i>Catn</i>

**Energy Industries of Ohio
Manufacturing and Test Sequence (MTS) A 2 Coil**

9 OF 11 CO# 40851 Dated 3-9-05 Revision: Rev 9 Dated Issued:9/26/05

453	INTERIM LAYOUT SOP LAYOUT 0100	INSPECT CASTING TO VERIFY DIMENSIONS. THIS STEP MAY BE MOVED. NOTE: THE FIRST PART PRODUCED OF EACH TYPE A, B AND C WILL BE DIMENSIONED BY LAWTON PATTERN. IF DIMENSIONED BY LAWTON IT WILL BE DOCUMENTED HERE. Subsequent casting done internally per Romer Arm.	JA	12/29
455	HEAT TREAT	STRESS RELIEF. Load casting into cold furnace. Ramp up to 1100 F at rate of 200 F per hour. Hold at temp 4 hours. Furnace cool to 500 F at 50 F per hour. Air cool. Submit furnace charts to QA.	KUE	12/15
NOTICE	WITNESS NOTIFICATION	PROVIDE NOTICE TO EIO AND DCMA AT LEAST FIVE DAYS IN ADVANCE OF VISUAL AND LP STEPS. EIO NOTIFIED ON <u>12/22</u> DCMA NOTIFIED ON <u>12/22</u>	Q ENG OR QA MGR	chr
460	FINAL VISUAL INSPECTION CQP-500 REV 4	VISUALLY INSPECT 100% of COMPONENT ACCORDING TO ASTM A802 LEVEL 3 ALL CONDITIONS. THIS STEP MAY BE UNNECESSARY IF OK AT STEP 350. IF OK CHECK HERE <input checked="" type="checkbox"/> IF REJECTED CHECK HERE <u> </u> . MARK AND REPAIR AT STEP 510. MUST BE PERFORMED BY LEVEL II in VT.	VT - LEVEL II KA	12/27
470	FINAL L.P. CQP 0300 REV 10	FINAL L.P. 100% OF COMPONENT. ACCEPTANCE PER ASTM A903. ACCEPTANCE CRITERIA-LEVEL 1 FOR HIGH STRESSED AREAS, LEVEL 2 FOR ALL OTHER AREAS. SEE LP DRAWING. THIS STEP MAY BE UNNECESSARY IF OK AT STEP 360. IF OK CHECK HERE <input checked="" type="checkbox"/> WASH AND SEND TO STEP 500. IF REJECTED CHECK HERE <u> </u> . DOCUMENT REPAIRS USING A SUPPLEMENTAL MTS.	LP - LEVEL II JSR	12/29
NOTICE	WITNESS NOTIFICATION	PROVIDE NOTICE TO EIO AND DCMA AT LEAST FIVE DAYS IN ADVANCE OF MAG PERM STEPS. EIO NOTIFIED ON <u>12/22</u> DCMA NOTIFIED ON <u>12/22</u>	Q ENG OR QA MGR	chr
500	FINAL MAG PERM INSPECTION SOP MAG PERM 100, REV 1	PERFORM MAG PERM TESTING WITH SEVRIN GAUGE. ACCEPTANCE 1.02. CHECK THE ENTIRE SURFACE ON A 6"BY6" GRID. REPORT RESULTS. USE A 6" SQUARE BLOCK TO INDICATE TEST LOCATIONS AND RECORD RESULTS. COMPLIANT AREAS WILL NOT BE MARKED. MARK NONCOMPLIANT AREAS WITH AN "X" FOR REPAIR. OK CHECK HERE <input checked="" type="checkbox"/> AND GO TO STEP 530. IF REJECTED CHECK HERE <u> </u> .	chr	12/29
510	GRIND GCHI SOP 0100 REV 2	HAND GRIND WITH SUITABLE CONE OR OTHER SIMILAR GRINDER AS REQUIRED TO ENSURE REMOVAL OF MATERIAL TO ACHIEVE MAG PERM REQUIREMENT. CIRCLE AREA REMEDIATE FOR RETEST.	NA	
520	RETEST MAG PERM SOP MAG PERM 100, REV 1	RETEST MAG PERMEABILITY AT FAILED TEST POINTS. MARK NONCOMPLIANT AREAS WITH AN "X" FOR REPAIR. ACCEPTANCE 1.02. IF OK CHECK HERE <u> </u> . IF REJECTED CHECK HERE <u> </u> RETURN TO STEP 510.	NA	
530	DOC. REVIEW	REVIEW DOCUMENTS AS REQUIRED IN CAF CHECKLIST, ALL DOCUMENTS NOTED TO BE ACCESSIBLE FOR AUDITING. (SHIPPER, C OF C, M.T.R., M.T.S., INSPECTION REPORT, X-RAY READER SHEETS AND HEAT TREAT CHARTS)	12/29	chr

Energy Industries of Ohio
Manufacturing and Test Sequence (MTS) A 2 Coil

10 OF 11 CO# 40851 Dated 3-9-05 Revision: Rev 9 Dated Issued:9/26/05

NOTICE	RELEASE FROM EIO	PROVIDE DOCUMENTS TO EIO. SENT ON <u>12/28</u> BY <u>Ch</u> RECEIVED RELEASE FROM EIO ON <u>+12/29</u>	Q ENG OR QA MGR	<u>Ch</u>
540	PACK AND SHIP	PACKAGE AND SHIP TO MAJOR TOOL.		
1000	REVISION HISTORY	ORIGINAL 12-14-04. Approved 12-14-04. Revision level 1- Revised 1-26-05 new page 8, correct High stress areas, Revision level 2 3-16-05, delete LO step 455. Revision 3 3-28-05 Added note regarding hold point at weld step 400. Revision level 4 written for C-2 casting 4-18-05. Rev 5 added Layout SOP# and note regarding first casting layout responsibility. 5-10-05. Rev 6 added word LOT to weld material steps. 5-29-05. Rev 7 6-14-05 added "LOT" to weld step on supplement page. Rev. 8 7-29-05 added stress relief, deleted weld hold points, added vertical weld procedure, and several editorial changes. REV 9 8-28-05 - MODIFIED RT STEPS AND ADDED REQUIREMENT TO RT ALL RT DEFECTS INCLUDING SURFACE.	CARUUD	

RED AREA INDICATES HIGH STRESSED AREA

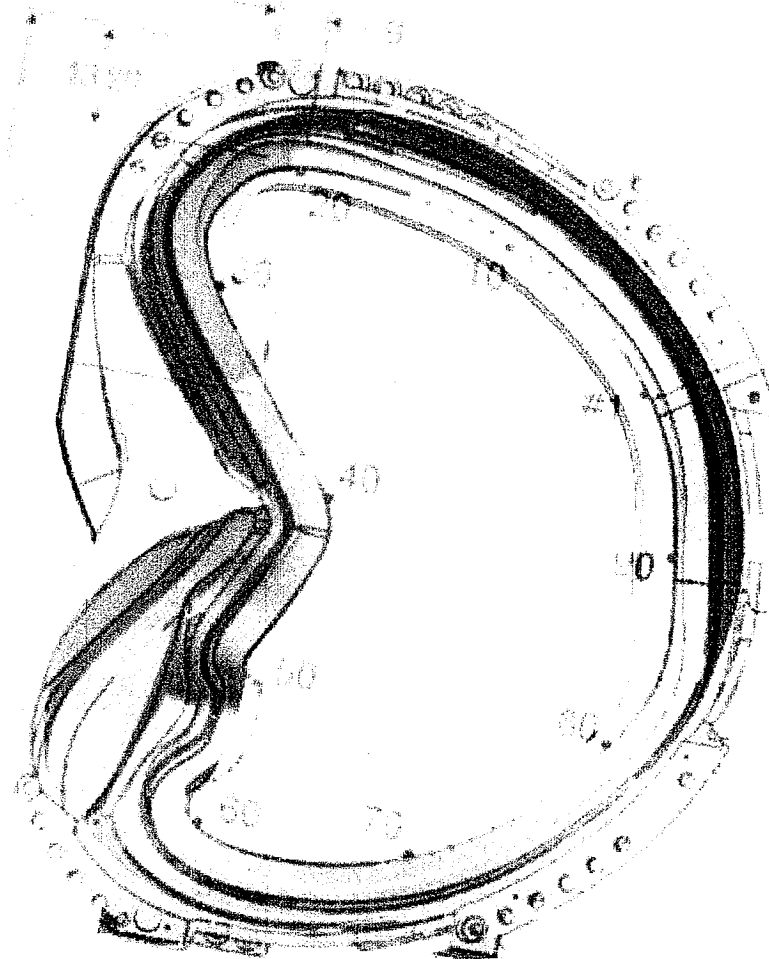
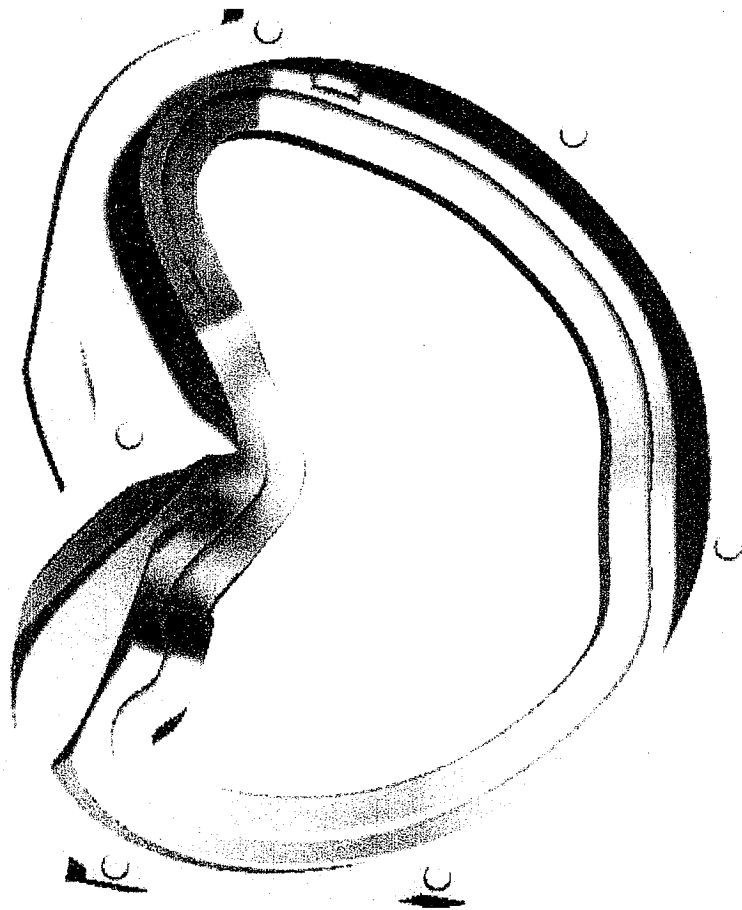

MetalTek International – Carondelet Division
Manufacturing and Test Sequence (MTS) Coil Shim A COIL S/N 2
Dated 12-14-04 Revision:1 Dated Issued:10-25-05 Page 1 of 3

OPER. #	STATION	DESCRIPTION OF PROCESS	Name	Date
10	QUALITY RELEASE	REVIEW AND APPROVE MTS. RECEIVED APPROVAL FROM EIO ON 11-1-05 FROM Pete D. SIGNED QUALITY MANAGER. SHADED BOXES NEED NOT BE SIGNED.	CAR	11-1-05
20	PATTERN NPAT SOP 0100REV2	APPLY APPROPRIATE PART NUMBER, SERIAL NUMBER, FOUNDRY MARK, TO THE PATTERN.		
30	MOLD	MOLD PER WORK INSTRUCTIONS IN MAPICS ROUTING AND SOPS REFERENCED. MOLD MATERIALS REQUIRED PER MAPICS BOM. NOTIFY ENGINEER OF ANY SUBSTITUTIONS. MOLD SOP 0400 REV 8 CALIBRATION PER MOLD SOP 0900 REV 5 PREPARATION PER MOLD SOP 1100R2/1200R2/1300R1 SAND TESTING PER MOLD SOP 1400R2/1500R3/1600R2		
40	POUR MELT SOP 0100R5 MELT SOP 0700R2 MELT SOP 0600R2	METAL MUST BE AOD REFINED OR AOD INGOT. VIRGIN METAL ADDITIONS ALLOWED. HEAT #: <u>29190</u> Sample from ladle to be analyzed for final chemical analysis and reported on material certifications. Sample Taken by: <u>SR</u> Analyzed: <u>GH</u>	JG	4/28/05
50	MELT SOP 0800R2	SHAKEOUT		
60	ARC RISE SOP 0100R1	REMOVE RISERS AS DIRECTED BY SUPERVISOR.		
70	HEAT TREAT HEAT SOP 0103R5	SOLUTION ANNEAL. MINIMUM 4 HOURS AT 2050 F. AIR COOL.	DLS	6/2/05
80	GRIND GSWA SOP 0100R3 GCHI SOP 0100R2	SWING GRIND TO REMOVE RISER REMAINS AND FLASH IF REQUIRED. CHIP AND HAND GRIND SURFACE OF PART AS REQUIRED.		
90	SAND BLAST BLAS SOP 0100R6	SANDBLAST (REMOVE ALL BLAST MATERIAL FROM CASTING) SANDBLASTING WILL BE DONE USING RECYCLED SHARP ANGULAR AGGREGATE.		
100	VISUAL INSPECTION CQP-500 REV 4	VISUALLY INSPECT 100% of COMPONENT ACCORDING TO ASTM A802 LEVEL 3 ALL CONDITIONS. IF OK CHECK HERE <input checked="" type="checkbox"/> IF REJECTED CHECK HERE <input type="checkbox"/> . MARK AND REPAIR AT STEP 130OR 140 IF WELDING IS REQUIRED. MAY PERFORM STEPS 110 AND 120 TOGETHER.	VT - LEVEL II KA	12/27

MetalTek International – Carondelet Division
Manufacturing and Test Sequence (MTS) Coil Shim A COIL S/N 2
Dated 12-14-04 Revision:1 Dated Issued:10-25-05 Page 2 of 3

120	100% L.P. CQP 0300 REV 10	L.P. 100% OF COMPONENT. ACCEPTANCE PER ASTM A903. ACCEPTANCE CRITERIA- LEVEL 2. IF OK CHECK HERE <u> </u> GO TO 150. IF REJECTED CHECK HERE <u> X </u> MARK AND REPAIR AT STEP 130 OR 140 IF WELDING IS REQUIRED.	LP - LEVEL II	SSB 12-27-05
130	GRIND GCHI SOP 0100R2	HAND GRIND DEFECTS. CONFIRM REPAIRS VISUALL AND BY LP. ACCEPTANCE AS NOTED ABOVE. IF OK, CHECK HERE <u> ✓ </u> AND GO TO STEP 170. IF WELDING IS NEEDED GO TO STEP 130.	CA	12/27/05
140 IF NEEDED		IF REPAIRS BY WELDING ARE REQUIRED DOCUMENT ON SUPPLEMENTAL MTS ON LAST PAGE.		
150	CAF X-RAY DEFECTS REPAIRED BY WELDING CQP 401 REV 5	X-RAY PER TECHNIQUE: SE-141-073-C SHIM. USE CALIBRATED DENSITOMETER FOR DENSITY VERIFICATION. ATTACH TECHNIQUE, READER SHEET FOR ALL RADIOGRAPHS. MUST INDICATE RADIOGRAPHER AND ASNT CERTIFICATION LEVEL ON READER SHEET.	RT - LEVEL II DM	12-16
160	X-RAY CQP 401 REV 5	X-RAY INTERPRETATION. ACCEPTANCE MSS SP 54. ATTACH TECHNIQUE, READER SHEET FOR ALL RADIOGRAPHS. MUST INDICATE RADIOGRAPHER AND ASNT CERTIFICATION LEVEL ON READER SHEET. IF OK CHECK HERE <u> ✓ </u> AND SEND TO STEP 200. REJECTED CHECK HERE <u> </u> MARK UP DEFECTS. DOCUMENT REPAIRS ON S10 TO S70.	RT - LEVEL II DM	12-16
	REPEAT	REPEAT STEPS S10 TO S70 AS REQUIRED TILL WELDS CLEAR X-RAY.	QA ENG.	NA
170	SAND BLAST BLAS SOP 0100R6	SANDBLAST (REMOVE ALL BLAST MATERIAL FROM CASTING) SANDBLASTING WILL BE DONE USING RECYCLED SHARP ANGULAR AGGREGATE.		
180	LAYOUT SOP 0100 ORIGINAL	INSPECT CASTING TO VERIFY DIMENSIONS. THIS MAY BE PERFORMED EARLIER IF DESIRED. SUBMIT RPORT TO QA.		12/28/05
190	FINAL VISUAL INSPECTION CQP-500 REV 4	VISUALLY INSPECT 100% of COMPONENT ACCORDING TO ASTM A802 LEVEL 2 ALL CONDITIONS. IF OK CHECK HERE <u> ✓ </u> . IF REJECTED CHECK HERE <u> </u> . MARK AND REPAIR DOCUMENT REWORK ON A SUPPLEMENTAL MTS	VT - LEVEL II KA	12-28
200	FINAL L.P. CQP 0300 REV 10	FINAL L.P. 100% OF COMPONENT. ACCEPTANCE PER ASTM A903. ACCEPTANCE CRITERIA- LEVEL 2 ALL AREAS. IF OK CHECK HERE <u> ✓ </u> WASH AND SEND TO NEXT STEP. IF REJECTED CHECK HERE <u> </u> MAKE REPAIRS AND DOCUMENT ON SUPPLEMENTL MTS.	LP - LEVEL II	SSB 12-27-05
210	FINAL MAG PERM INSPECTION SOP MAG PERM 100, REV 1 GRIND GCHI SOP 0100 REV 2	PERFORM MAG PERM TESTING WITH SEVRIN GAUGE. ACCEPTANCE 1.02. CHECK THE ENTIRE SURFACE ON A 6"BY6" GRID. REPORT RESULTS. HAND GRIND WITH SUITABLE CONE OR OTHER SIMILAR GRINDER AS REQUIRED TO ENSURE REMOVAL OF MATERIAL TO ACHIEVE MAG PERM REQUIREMENT.	CA	12-29-05
220	DOC. REVIEW	REVIEW DOCUMENTS ALL DOCUMENTS NOTED TO BE ACCESSIBLE FOR AUDITING. (C OF C, M.T.R., SIGNED M.T.S., LAYOUT INSPECTION REPORT, X-RAY READER SHEETS AND HEAT TREAT CHARTS)		

MetalTek International – Carondelet Division
Manufacturing and Test Sequence (MTS) Coil Shim A COIL S/N 2
Dated 12-14-04 Revision:1 Dated Issued:10-25-05 Page 3of 3

NOTICE	RELEASE FROM EIO	PROVIDE DOCUMENTS TO EIO. SENT ON _____ BY _____ RECEIVED RELEASE FROM EIO ON _____.	Q ENG OR QA MGR	
	PACK AND SHIP	PACKAGE AND SHIP TO MAJOR TOOL.		
1000	REVISION HISTORY	ORIGINAL 12-14-04. Rev1 complete rewrite due to specification changes.	CARUUD	
FOR VT&LP/ FOR RT				
SUPPLEMENTAL MTS FOR WELD REPAIRS.				
S10	WELD SOP 0100 REV 7	EXCAVATE ANY DEFECTS.		
S20	L.P. EXCAVATION CQP-300 REV 10	L.P. ALL EXCAVATIONS PRIOR TO WELDING TO ENSURE REMOVAL OF DEFECT. ACCEPTANCE PER A903. ACCEPTANCE CRITERIA- LEVEL 2.	LP - LEVEL II	LP - LEVEL II
S30	WELD MAP	MAP ALL WELDS WITH DIGITAL PHOTO/MAPS. SERIALIZE DEFECTS ON CASTING, USE SCALE IN PHOTOS AND DOCUMENT SIZE. THIS IS TO BE PERFORMED BY SUPERVISOR, INSPECTION LEAD MAN OR THEIR DESIGNEE, FILE WITH QA.. USE YELLOW MARKER. MUST SEND REPORT ON ALL AJOR WELDS, DEFINED AS OVER 20% OF WALL THICKNESS OR 1 INCH WHICHEVER IS LESS OR 10 SQUARE INCHES TO CUSTOMER. MAJOR WELDS YES _____, REPORT SENT BY _____ DATE _____ NO MAJOR WELDS CHECK HERE _____ AND GO TO STEP 170.		
S40	QA APPROVAL HOLD POINT	QA TO APPROVE ELECTRODE PRIOR TO USE. PROCEDURE USED: _____ MATERIAL USED: _____ QUALITY ENG. Name: _____ Date: _____		
S50	WELD SOP 0100 REV 7	WELD REPAIR DEFECTS AS MARKED. FOR WELDS <2" - WPS 10-SMAW-CF8MNMN MOD REV 1 FOR WELDS <8" - WPS 15-GMAW-CF8MNMN MOD REV 2		
S60	GRIND GCHI SOP 0100R2	HAND GRIND WELDS.		
S70	L.P. WELD CQP 0300 REV 10	L.P. WELD REPAIRS ACCEPTANCE PER ASTM A903. ACCEPTANCE CRITERIA-LEVEL 2. IF OK CHECK HERE _____ WASH AND SEND TO STEP 300. IF REJECTED CHECK HERE _____ AND RETURN TO STEP 220.	LP - LEVEL II	LP - LEVEL II
	REPEAT	REPEAT STEPSS10 TO S70 AS REQUIRED TILL CLEAR THROUGH VISUAL INSPECTION & PENETRANT INSPECTION.	QA ENG.	QA ENG.
S80	TEST MAG PERM SOP MAG PERM 100, REV 1	TEST MAG PERMEABILITY REPAIR AREAS RECORD ON WELD MAP LIST. TEST AT LEAST 5 POINTS PER WELD. ACCEPTANCE 1.02. IF OK CHECK HERE _____ AND GO TO STEP 170. GRIND AS NEEDED TO REMEDIATE.		

UA



4

Corrective Action 1308
Carondelet Division - CA / PA / RGA Database
Corrective Action Type NCR
Date 6/13/2005
CA Originator C. Ruud
Pattern Number: C and A Coil Shims 11 Pieces

Description of Defect / Non-Conformance

Chemistry for 11 shim castings is out of specification.

Root Cause

Chemistry specification was not changed in system and not communicated to Lab personnel.

Corrective Action

Specification was corrected in system and Lab personnel trained. Mag permeability was checked on the parts and are less than 1.02u.

Verification of Corrective Action

Chemistries were checked on subsequent parts and are within specification.

Preventive Action

Create Inspection and Test Plan summarizing all requirements.

Estimated Completion Date

6/15/05

Actual Completion Date

Complete.

A handwritten signature in black ink, appearing to read "C. Ruud".

Signed: C. Ruud

CC: Roger Broman, Barry Craig, Joe Edwards, E.J. Kubick

Nonconformance Report: CA 1323 (phosphorus levels exceeds specification limits for castings C1- C4 and A1 and C1 shim and four Type C and six A coil shims)

Project Disposition:

The erroneous levels were due to calibration errors with the spectrometer. As reported in MTK's attached report, preventive maintenance has since been performed on the spectrometer. The reported chemistry will be accepted for the castings and shims noted above. The specification chemistry will not be changed at this time.

Approvals:

**Phil
Heitzenroeder**

Digitally signed by Phil Heitzenroeder
DN: CN = Phil Heitzenroeder, C = US,
O = PPPL, OU = Mech. Eng. Division
Reason: I agree to 'specified' portions
of this document
Date: 2006.02.21 11:49:56 -05'00'

Procurement Technical Representative

**Brad
Nelson**

Digitally signed by Brad Nelson
DN: cn=Brad Nelson, c=US,
o=ORNL, ou=FED,
email=nelsonbe@ornl.gov
Date: 2006.02.21 14:16:12
-05'00'

Responsible Line Manager:



Corrective Action 1323
Carondelet Division - CA / PA / RGA Database
Corrective Action Type NCR
Date 7/27/2005
CA Originator C. Ruud
Applies to: Coil castings C-1, C-2, C-3, C-4 and A-1 and C 1 shim and four C coil and six A coil shims

Description of Defect / Non-Conformance

Phosphorus levels in material produced to date exceed specification limits. Both phosphorus and sulfur readings reported erroneously in certifications.

Certification reports have shown phosphorus and sulfur levels in the <.01% range. Independent laboratory data confirmed phosphorus in the .018 to .033% range and sulfur in the .005 to .022% range. Actual levels of some tests are above those in PPPL Specification NCSX-CSPEC-141-03-07 Rev 7.

Nonconformance was first suspected as a result of analysis of zoned attached test specimens volunteered by MetalTek International as response to PPPL questions on weighted average chemical analysis and quality of blending in the gating system. Nonconformance was verified on the bars used in the study and has been extended to evaluation of previously poured products.

Root Cause

Specification limits were set below the levels achievable through use of available raw materials. Spectrometer did not properly calibrate for phosphorus and sulfur at levels of specification due to equipment malfunction.

The chemical specification of EIO heats uses alloy CF8MNMn-Mod which incorporates a type standard calibration with a certified reference material (CRM) BS180. This enables the operator of the spectrometer to match the elemental concentrations of this alloy with corrective factors. These factors are determined by analyzing the CRM and having them compared with the calibration curves for each element. The phosphorus and sulfur content have very low measured intensities due to low concentrations. Intermittent failure of the spectrometer intensity measuring card caused higher intensity readings for phosphorus and sulfur. Subsequent checks with the CRM resulted in low corrective factors that were not detected. This in turn resulted in low reported concentrations for the EIO samples. All the major elements, which are measured on other intensity cards, have been closely monitored and matched very well with the CRM and thus were reported correctly.

Corrective Action

Modification to specification for phosphorus and sulfur will be requested. Limits will be set based on process capability and consistent with other stainless steel grades. Replacement of deficient card in spectrometer will be made upon delivery.

Subsequent immediate analysis of chemistry results, obtained by wet analysis, is attached and demonstrate top of specification for sulfur and over specification for phosphorus. The spectrometer manufacturer has performed an analysis to determine the cause of the malfunction and verified that the intensity card has an intermittent fault and must be replaced. The card has been ordered and scheduled for replacement on August 15, 2005.

Until the card is replaced we will be performing additional type standardizations to ensure accurate sulfur and phosphorus analysis. Additionally, for coils made until the card is replaced, an independent laboratory will perform a verification of the chemical analysis.

Verification of Corrective Action

Will be determined at a later date.

Preventive Action

In addition to spectrometer faults, we have identified that the specification ranges for sulfur and phosphorus is unattainable. Analysis and specifications for virgin charge materials predict sulfur at 0.040% maximum and phosphorus at 0.040% maximum. We have no way to remove phosphorus from the melt and do not intentionally add phosphorus. So, the confirmed coil analyses, along with analyses of virgin material heats, demonstrate sulfur in the range of 0.010% to 0.022% and phosphorus in the range of 0.018% to 0.033%. These results are consistent with our charge material analysis. We will request a deviation for phosphorus in the subject parts and also request a permanent specification change to 0.040% maximum for both phosphorus and sulfur, to allow us to provide non-discrepant material. This change will not affect, in any way, the physical properties or material performance because all coils and test material exhibited sulfur and phosphorus within the new ranges despite inaccurate reporting. Other actions: Specifications have been added to the BS 180 standard and the type standard will be measured against the criteria.

Estimated Completion Date

August 15, 2005

Actual Completion Date TBD

Signed: C. Ruud



CC: Jim Galaske, Barry Craig, Joe Edwards, E.J. Kubick

Guide to St Louis Testing Report Dated 7-26-05

Sample name	Sample origin
A1Z1	Cast on bar A-1 coil, zone 1
A1Z2	Cast on bar A-1 coil, zone 2
A1Z3	Cast on bar A-1 coil, zone 3
C1	Cast on bar C-1 coil
C2Z1	Cast on bar C-2 coil, zone 1
C2Z2	Cast on bar C-2 coil, zone 2
C2Z3	Cast on bar C-2 coil, zone 3
C3Z1	Cast on bar C-3 coil, zone 1
C3Z2	Cast on bar C-3 coil, zone 2
C3Z3	Cast on bar C-3 coil, zone 3
F1	Final analysis button from ladle for C-4 coil
F2	Final analysis button from ladle for C-4 coil
F3	Final analysis button from ladle for C-4 coil
P1	Preliminary analysis button from ladle for C-4 coil

Testing is underway of the heat used to pour the four C coil and six A coil shims.

*Attachment to
CA 1323*



Chemical, Metallurgical, Mechanical, Nondestructive, Environmental Testing, Analyses and Field Service.

July 26, 2005
Lab No. 05C-0608
Invoice No. 59891
P.O. No. 21324
Page 1 of 1

METALTEK INTERNATIONAL
8600 Commercial Blvd.
Pevely, MO 63070

Attention: Chuck Ruud

REPORT OF CHEMICAL ANALYSIS

SAMPLE ID: A1 Z1, A1 Z2, A1 Z3, C1, C2 Z1, C2 Z2, C2 Z3,
C3 Z1, C3 Z2, C3 Z3, F1, F2, F3, P1

RESULTS: %

ANALYTE	A1Z1	A1Z2	A1Z3
Sulfur	.013	.005	.010
Phosphorus	.025	.023	.018

ANALYTE	C1	C2Z1	C2Z2	C2Z3
Sulfur	.014	.022	.018	.015
Phosphorus	.018	.024	.021	.025

ANALYTE	C3Z1	C3Z2	C3Z3
Sulfur	.013	.014	.012
Phosphorus	.024	.025	.021

ANALYTE	F1	F2	F3	P1
Sulfur	.014	.015	.012	.010
Phosphorus	.029	.033	.028	.030

Sulfur Test Method: ASTM E1019-03

Phosphorous Test Method: Colormetric

Identification of tested specimen provided by the client.

Robin E. Sinn
Laboratory Director





Corrective Action 1525
Carondelet Division
Corrective Action Type NCR
Date 1-9-06
CA Originator C. Ruud
Applies to: A-2 Coil

Description of Defect / Non-Conformance

A-2 Coil has excess stock in 2 areas.

Root Cause

Excess material is feed pads for risers. They were not removed during arc air operation. There is no work instruction for the A coil.

Corrective Action

Remove excess material at CAF. Verify repairs.

Verification of Corrective Action

Inspect coil prior to shipping.

Preventive Action

Create work instruction for arc air process.

Verification Of Preventative Action

Work instruction completed and will be verified on A-4.

Estimated Completion Date

1-20-06

Actual Completion Date

Signed: C. Ruud

A handwritten signature in black ink, appearing to read "C. Ruud".

CC: R. Broman, B. Craig, J. Edwards, E.J. Kubick, J. Markham, B. Carlton



Corrective Action 1530
Carondelet Division
Corrective Action Type NCR
Date 1-11-06
CA Originator C. Ruud
Applies to: A-2 Coil

Description of Defect / Non-Conformance

Markings on A-2 Coil are incorrect. Serial number "A-2" was not on coil.

Root Cause

Serial numbers in core box was not changed to A-2. Certification number on A-2 was in an area that was repaired and as a result it was ground off.

Corrective Action

Serial numbers in the core box have been changed. The MTS has been revised to have the markings verified at final inspection.

Verification of Corrective Action

Numbers in A-5 were checked on 1-12-06 prior to pouring and found to be compliant.

Estimated Completion Date

Prior to pouring of A-5.

Actual Completion Date

1/12/06

A handwritten signature in black ink, appearing to read "C. Ruud".

Signed: C. Ruud

CC: R. Broman, B. Craig, J. Edwards, E.J. Kubick, J. Markham, B. Carlton



17

Carondelet Division

8600 Commercial Blvd. - Pevely, MO 63070 USA
Phone: 636-479-4499 - Fax: 636-479-3399

Final Inspection Report

Customer ENERGY INDUSTRIES OF OHIO
Pattern: MCWF-A2 COIL

Order PPPL-FP-LTS-2

ASTM Metal CF8MNMN MOD

Date 12/29/2005

Type Description	Cert Number	Procedure	Acceptance Criteria	Actual
Liquid Penetrant	175410-1	CQP - 300 Rev 9	SEE NOTE	Acceptable
Notes Acceptance per ASTM A903. Acceptance criteria - level 1 for high stressed areas, level 2 for all other areas.				
Mag Perm	175410-1	SOP Mag Perm 100 Rev 1	<1.02	Acceptable
Radiographic	175410-1	Technique # 12726	MSS SP 54	Acceptable
Visual	175410-1	CQP - 500 REV 4	ASTM A802 LEVEL 2	Acceptable

Liquid Penetrant

Technician: Jim Shanahan
ASNT Level II

Visual

Technician: Kevin Anderson
ASNT Level II

Respectfully Submitted,
Charles A. Ruud
Quality Assurance Manager

Superior Quality Engineered Metal Products



Carondelet Division

8600 Commercial Blvd. - Pevely, MO 63070 USA
Phone: 636-479-4499 - Fax: 636-479-3399

Certificate of Conformance

ENERGY INDUSTRIES OF OHIO

Order Number PPPL-FP-LTS-2

Pattern MCWF-A2 COIL

ASTM CF8MNMN MOD

Date 12/29/2005

Cert Number

175410-1

A handwritten signature in black ink, appearing to read "C. Ruud", is written over a horizontal line.

We certify that we have complied in accordance with the drawings(s) and specifications(s) listed on the above purchase order. The articles furnished were made and/or processed from parts and/or materials in accordance with all applicable drawings(s) and specifications(s) pursuant to the afore mention purchase order.

Respectfully Submitted,
Charles A. Ruud
Quality Assurance Manager

Superior Quality Engineered Metal Products

www.MetalTekInt.Com



Carondelet Division

8600 Commercial Blvd. - Pevely, MO 63070 USA
Phone: 636-479-4499 - Fax: 636-479-3399

Final Inspection Report

Customer Name: ENERGY INDUSTRIES OF OHIO

Pattern: SE-141-033 COIL A SHIM
S/N 2

Order Number: PPPL-FP-LTS-2

ASTM Metal CF8MNMN MOD

Date 12/28/2005

Type Description	Cert Number	Procedure	Acceptance Criteria	Actual
Liquid Penetrant	S76220-1	CQP - 300 Rev 9	ASTM A903 Level II	Acceptable
Mag Perm	S76220-1	SOP Mag Perm 100 Rev 1	<1.02	Acceptable
Radiographic	S76220-1	Technique # 12726	MSS SP 54	Acceptable
Visual	S76220-1	CQP - 500 REV 4	ASTM A802 LEVEL 2	Acceptable

Liquid Penetrant

Technician: Sharon Bader
ASNT Level II

Visual

Technician: Kevin Anderson
ASNT Level II

Respectfully Submitted,
Charles A. Ruud
Quality Assurance Manager



3

Carondelet Division

8600 Commercial Blvd. - Pevely, MO 63070 USA
Phone: 636-479-4499 - Fax: 636-479-3399

Certificate of Conformance

ENERGY INDUSTRIES OF OHIO

Order Number PPPL-FP-LTS-2

Pattern SE-141-033 COIL A SHIM S/N 2

Alloy CF8MNMnMOD

Date 12/29/2005

Cert Number

S76220-1

A shim for A-2 coil was poured from heat number 29198. No weld repairs were necessary.

A handwritten signature in black ink, appearing to read "CAR", with a long horizontal line extending to the right.

We certify that we have complied in accordance with the drawings(s) and specifications(s) listed on the above purchase order. The articles furnished were made and/or processed from parts and/or materials in accordance with all applicable drawings(s) and specifications(s) pursuant to the afore mention purchase order except as noted by corrective actions.

Respectfully Submitted,
Charles A. Ruud
Quality Assurance Manager

Superior Quality Engineered Metal Products

www.MetalTekInt.Com

EIO
Energy Industries of Ohio
SUPPLIER QUALITY RELEASE

		Date: 12-29-05
--	--	----------------

I. General Information:		
Project Name:	Modular Coil Winding Form A2	
PO No:	NCSX-SOW-141-02-01	Rev.: 9
Supplier:	MetalTek	
Procurement Agent:	EIO	
Shipment:	<input checked="" type="checkbox"/> Partial <input type="checkbox"/> Final	

II. Material Description
Casting A2 Coil Shim A coil S/N 2

III. Release Checklist	
Plan Requirements Complete?	<input checked="" type="checkbox"/> Yes <input type="checkbox"/> No <input type="checkbox"/> N/A (If identified "No" provide explanation in comments section below)
Variances?	<input checked="" type="checkbox"/> Yes <input type="checkbox"/> No <input type="checkbox"/> N/A (If identified "No" provide explanation in comments section below)
Princeton Notified of Shipment?	<input checked="" type="checkbox"/> Yes <input type="checkbox"/> No <input type="checkbox"/> N/A (If identified "No" provide explanation in comments section below)
DCMA Notified of Shipment?	<input checked="" type="checkbox"/> Yes <input type="checkbox"/> No <input type="checkbox"/> N/A (If identified "No" provide explanation in comments section below)
<input checked="" type="checkbox"/> Conditional <input type="checkbox"/> Unconditional Explain conditional releases in comments section.	

IV. Comments
Metallurgical variance per NCR 1323 & WC specs (Pending PPPL approval and final disposition) Manganese high

By signing below you acknowledge that the casting has met all applicable standards and contractual requirements

V. Supplier Quality Representative Sign Off		
Charles Ruud	X	12-29-05
Supplier Quality Representative (SQR) Print/Type Name	Supplier Quality Representative (SQR) Signature	Date

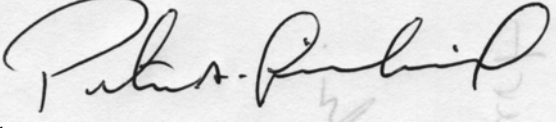
VI. Supplier Approval For Shipment		
Procurement Agent Notified of Shipment	Date: 12-29-05	
Required Vendor Data Ready for Shipment	Date: 12-29-05	
Peter A Djordjevich	 X	12-29-05

EIO
Energy Industries of Ohio
SUPPLIER QUALITY RELEASE

		Date: 12-29-05
--	--	----------------

I. General Information:		
Project Name:	Modular Coil Winding Form A2	
PO No:	NCSX-SOW-141-02-01	Rev.: 9
Supplier:	MetalTek	
Procurement Agent:	EIO	
Shipment:	<input checked="" type="checkbox"/> Partial <input type="checkbox"/> Final	
Supplier's Representative Print/Type Name	Supplier's Signature	Date

1. Enter:
Project Name
PO Number
Supplier
Procurement Agent

2. Enter a brief description of items being released, including applicable drawing number(s), dash or item number(s), drawing revision letter, specification(s), and serial number(s).

3. Self-Explanatory

4. Record any unusual circumstance, such as a conditional release.

5. The Supplier's representative shall sign and date.

7. Signature and date of the Supplier's authorized representative indicating shipping date.

8. In case of partial release, the supplier shall maintain copies of each sequential "Supplier Quality Release" and establish complete accountability of material release on final shipment.

9. Supplier shall include a copy of the completed form with each shipment.

Energy Industries of Ohio

Contract # S005242-F

Modular Coil Winding Form

A-2 Documentation Package

Part 2

Major Tool & Machine

Revised 8/29/2006

****Note – The table of contents that follows a supplemental EIO TOC as an aide to locating documents. Documents may be duplicated in this package; 1st as an attachment to a NC (not listed) & the 2nd time in the order noted in the MTM TOC.**

A-2 Documentation Package

List of Documents 8-29-06

Doc #	Description	Page #
-	MTM – Original TOC & document list	67
1	Certificate of Conformance	69
2	Completed shop travelers – 65709-/2.0	70
3	NC 20044 PT Rejections	75
4	NC 200080 Final Dimensional & misc. items	85
5	Material certification Loctite 411	89
6 & 11	Material certification G-11 round bar	90
7	IDC – Electrical Resistance Check	92
8	Material certification – weld wire – Metrode lot # W020132 Test certificate # 193695 & 194227	93
9	Westmoreland test results Metrode weld lot # W020132	95
10	Material certification – GE G11-CR flat sheet insulating material	99
11	Material certification G-11 round bar (Same as document 10)	90
12	LP inspection certificate – Final inspection #17119	100
13	IDC – Poloidal break	101
14	IDC – Final dimensional	102
15	MQS – RT map & reader sheet	108
16	IDC – Mag perm – Final inspection	111
17	Material certificate – South Texas Bolt - stud	112
18	Material certificate – South Texas Bolt - nuts	113
19	Material certificate – South Texas Bolt – nuts (additional quantity)	114
20	IDC – Mag Permeability of bearing plates - short	115
21	IDC – Mag Permeability of bearing plates - long	116
**	PPPL shipping release for A-2 – Did not appear in original MTM Doc package – Not reflected in MTM TOC which follows (page 67)	117

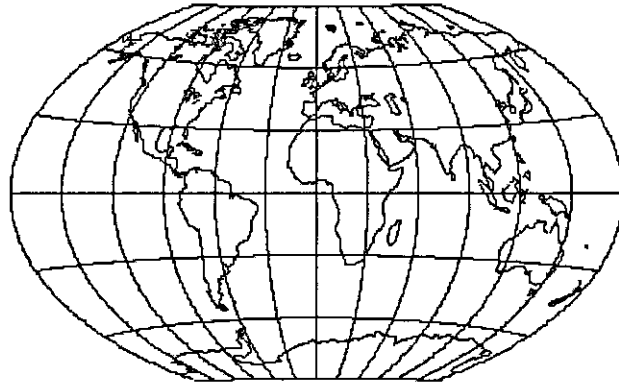

ENERGY INDUSTRIES OF OH

Purchase Order Number:

S005242-F

Part Number:

SE141-114

Part Name:

MCWF A-2

MTM Work Order Number:

65709/2.0



Major

Tool & Machine, Inc.

Table of Contents
Quality Assurance Documents For
Workorder: 65709/2.0

Page: 1
Date: 08/02/06
User ID: GRIFFIT#

Customer: 8909 - ENERGY INDUSTRIES OF OHIO
Customer P.O.: S005242-F
Customer Part ID: SE141-114 - MCWF A-2

Item#	Document Description / Material Description / File Name / Heat Lot
1	CERTIFICATE OF CONFORMANCE
2	COMPLETED SHOP TRAVELERS: - 65709-2 completed shop travelers.pdf
3	NC20044 - PT REJECTIONS: - NC20044_S5242.pdf
4	NC20080 - FINAL DIMENSIONAL AND MISC. ITEMS: - NC20080_S5242_.pdf

SE141-048 - POLOIDAL BREAK SHIM ASSEMBLY

Item#	Sub	Op	Pc	Document Description / Material Description / File Name / Heat Lot
5	2	30	20	Certificate of Conformance: FROM SUPPLIER / LOCTITE 411 - LOCKING COMPOUND - mc106320.tif / CERTIFIED

SE141-048-03 - INSULATING SLEEVE

Item#	Sub	Op	Pc	Document Description / Material Description / File Name / Heat Lot
6	3	10	10	Certificate of Conformance: / G11CR_1 - ROUND, BAR, 1.75 DIA - mc108545.tif / CERTIFIED

SE141-101

Item#	Sub	Op	Pc	Document Description / Material Description / File Name / Heat Lot
7	1	140		Inspection Data Checklist: 2 steps

SE141-101-1 - MOD COIL WINDING FORM ASSEMBLY TYPE-A

Item#	Sub	Op	Pc	Document Description / Material Description / File Name / Heat Lot
8	0	10	10	Material Certification: Trace ID: 116252 / ER316MNNF_093_GTAW - WELD WIRE,GTAW .093 DIA - mc106579.tif / W020132 / W020132
9	0	10	10	Material Certification: Trace ID: 113688 / ER316MNNF_093_GTAW - WELD WIRE,GTAW .093 DIA - mc106164.pdf / W020132 / W020132

SE141-101-4 - INSULATING SHEET

Item#	Sub	Op	Pc	Document Description / Material Description / File Name / Heat Lot
10	7	10	10	Certificate of Conformance: G11CR / G11CR_3 - SHEET, FLAT - mc107081.tif / CERTIFIED

SE141-101-5 - INSULATING SLEEVE

Item#	Sub	Op	Pc	Document Description / Material Description / File Name / Heat Lot
11	5	10	10	Certificate of Conformance: / G11CR_1 - ROUND, BAR, 1.75 DIA - Same as Item #6 / CERTIFIED

SE141-114 - MODULAR COIL WINDING FORM TYPE-A

Item#	Sub	Op	Pc	Document Description / Material Description / File Name / Heat Lot
12	1	100		Nondestructive Liquid Penetrant Test Certification #17119
13	1	130		Inspection Data Checklist: 5 steps
14	1	132		Inspection Data Checklist: 80 steps
15	1	134		Map(s): RT MAP AND READER SHEET - MC119588.PDF
16	1	136		Inspection Data Checklist: 2 steps
17	12	10	10	Material Certification: / DS141-036 - STUD - mc118607.tif / XFR/E3930
18	12	10	20	Material Certification: / DS141-060 - NUT - mc118688.tif / XFQ/5407813
19	12	10	20	Material Certification: Trace ID: 144892 / DS141-060 - NUT - mc118608.tif / XFQ/5407813



Customer: 8909 - ENERGY INDUSTRIES OF OHIO
Customer P.O.: S005242-F
Customer Part ID: SE141-114 - MCWF A-2

SE141-141 - BEARING PLATE DETAIL TYPE "A" SHORT

Item#	Sub	Op	Pc	Document Description / Material Description / File Name / Heat Lot
20	14	30		Inspection Data Checklist: 1 steps

SE141-142 - BEARING PLATE DETAIL TYPE "A" LONG

Item#	Sub	Op	Pc	Document Description / Material Description / File Name / Heat Lot
21	15	30		Inspection Data Checklist: 1 steps

CERTIFICATE OF CONFORMANCE

Page: 1
Date: 08/02/06
User ID: GRIFFIT#

TO: ENERGY INDUSTRIES OF OHIO

DATE: 06/28/2006

ATTENTION: Receiving Department

Seller certifies that:

Part Number: SE141-114

Purchase Order: S005242-F

Part Name: MCWF A-2

Workorder: 65709/2.0

Part Serial Number: A-2

Quantity: 1

1. These materials and/or parts were produced in conformance with all contractually applicable Government and/or Customer specifications referred in, or furnished with, the above Purchase Order.
2. The materials and/or parts furnished under the above Purchase Order were produced:
 - From materials furnished by Customer for the production of such parts.
 - From materials for which the seller has available for examination chemical and/or physical test reports or other evidence of conformance to applicable specifications.
3. All processes required in the production of these part and/or materials are listed below and were performed by a facility or personnel approved or certified by the Seller and the customer when such approval or certification is required by contract.

Certifications are on file at this plant.

Other Requirements:

MANUFACTURED PER B.P. SE141-101 REV. 3 AND P.O. REQUIREMENTS.

Signature: _____

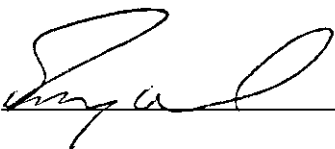

Title: _____

Quality Manager

Date: _____

8/2/06



Activity	Visual Mfg Ref.	Op Status	Close Date	Emp ID
Manufacturing Planning- QA planning- Production Support	65709/2.0 -Sub:0 Op#:10	Closed	6/27/2006	840-G.Masood
PREPARE DOCUMENTATION TO PRESENT TO GOVERNMENT SOURCE INSPECTOR.	65709/2.0 -Sub:0 Op#:20	Closed	6/27/2006	840-G.Masood
REVIEW RESULTS FROM THE FOLLOWING INSEPCTIONS:-- PENETRANT INSPECTION (PT)--RADIOGRAPHIC INSPECTION (RT)-- FINAL DIMENSIONAL INSPECTION--MAG PERMEABILITY-- ELECTRICAL RESISTANCE--	65709/2.0 -Sub:0 Op#:30	Closed	6/27/2006	840-G.Masood
ORIENT PART WITH DATUM E FLANGE DOWN.---ENUSURE PART SURFACES ARE CLEAN AND FREE OF GRIT AND DEBRIS. THE PART IS NOT TO BE OILED.--THE ENTIRE PART IS TO BE WRAPPED IN PLASTIC.--PLACE FOAM ON THE 4X6 BEAMS THAT THE FLANGE WILL BE SITTING ON. LOWER THE PAR	65709/2.0 -Sub:0 Op#:40	Closed	6/29/2006	567-R.Hupp
Receive customer supplied material. -----Part Number: SE141-114 Rev: 5-- Part Description: PRODUCTION WINDING FORM TYPE-A	65709/2.0 -Sub:1 Op#:10	Closed	1/5/2006	437-J.Hiatt
SETUP 1 - MTMFX -3101 WITH DATUM E SIDE OF PART AGAINST FIXTURE.--SETUP 2 - MTMFX-3102 WITH DATUM D SIDE OF PART AGAINST FIXTURE.---SETUP AND MACHINE THE FLANGE FACES AND FLANGE PERIPHERY TO WITHIN .100- STOCK. --FINISH MACHINE THE WING SURFACES ABOVE EA	65709/2.0 -Sub:1 Op#:18	Closed	2/27/2006	535-S.Lentz
WELD A U-SHAPED BRACE ACROSS THE TOP OF THE -T-.----PLACE PART ON RISERS OR TIMBERS WITH THE SIDE FACING UP THAT HAS THREE OF THE FOUR AREAS TO BE CUT OUT. ---THE BOTTOM CUT OUT WILL BE PREFORMED FIRST- THEN PROCEED WITH THE 3 UPPER CUT OUTS- DO NOT FLIP	65709/2.0 -Sub:1 Op#:19	Closed	2/27/2006	233-G.Stupples
SET CASTING ON RISERS WITH DATUM -E- FLANGE DOWN. TAB DATUM -E- FLANGE TO THE RISER ON EITHER SIDE OF THE BREAK TO PREVENT MOVEMENT AFTER MACHINING THE BREAK THROUGH. WELD CHANNEL BRACE ACROSS THE LARGE CUTOUT ADJACENT TO THE BREAK.--FINISH MACHINE THE PO	65709/2.0 -Sub:1 Op#:20	Closed	3/7/2006	535-S.Lentz
SET UP FIXTURE PLATE MTMFX-3101 AND MACHINE LOCATING PADS AS NECESSARY.--SET UP CASTING WITH DATUM -E- AGAINST THE FIXTURE.--- FINISH MACHINE ALL AREAS BELOW THE T SECTION.--- MACHINE T SECTION TO WITHIN .030-.--- FINISH MACHINE DATUM -D- FLANGE.--	65709/2.0 -Sub:1 Op#:30	Closed	5/26/2006	345-D.Sauser



Activity	Visual Mfg Ref.	Op Status	Close Date	Emp ID
SET UP FIXTURE PLATE MTMFX-3102 AND MACHINE LOCATING PADS AS NECESSARY.--SET UP CASTING WITH DATUM -D- AGAINST THE FIXTURE.-- FINISH MACHINE ALL AREAS BELOW THE T SECTION.-- MACHINE T SECTION TO WITHIN .030.-- FINISH MACHINE DATUM -E- FLANGE.-	65709/2.0 -Sub:1 Op#:35	Closed	6/7/2006	576-J.Geisinger
THIS OPERATION CONSISTS OF 3 SETUPS.--SETUP #1: ANGLE BASE AND FIXTURE MTMFX-3101-- DATUM -E- FLANGE DOWN.--SETUP #2: ANGLE BASE AND FIXTURE MTMFX-3102-- DATUM -D- FLANGE DOWN.--SETUP #3: RISERS AND FIXTURE MTMFX-3102-- DATUM -D- FLANGE DOWN.----MACHINE P	65709/2.0 -Sub:1 Op#:50	Closed	6/16/2006	274-M.Moorman
PROTECT PART FROM METAL CONTAMINATION DUE TO CONTACT WITH IRON- SPECIFICALLY WHEN RIGGING PART FOR MOVEMENT.-- ALL GRINDING WHEELS AND DISKS MUST BE VIRGIN MATERIAL NOT PREVIOUSLY USED ON ANY OTHER MATERIAL TO AVOID MATERIAL CONTAMINATION.--- CAREFULLY R	65709/2.0 -Sub:1 Op#:88	Closed	6/21/2006	219-T.Laird
PROTECT PART FROM METAL CONTAMINATION DUE TO CONTACT WITH IRON- SPECIFICALLY WHEN RIGGING PART FOR MOVEMENT.-- MOVE PART INTO WASH BOOTH. --THOROUGHLY CLEAN AND DRY ALL SURFACES AND HOLES PER SECTION 9 OF PS583. --PARTS TO BE WASHED USING HEATED- DE-MINERA	65709/2.0 -Sub:1 Op#:90	Closed	6/19/2006	219-T.Laird
PT 100% OF ALL MACHINED AND GROUND SURFACES. EXCLUDE THE PROCESSING OF ANY AS-CAST SURFACE.--SEE PS582 FOR PROCESSING INSTRUCTIONS. ---TAKE PHOTOS OF ALL REJECTIONS AND NUMBER THEM. IF THERE ARE SEVERAL INDICATIONS CLOSE TOGETHER- NUMBER THE GROUP AND RE	65709/2.0 -Sub:1 Op#:100	Closed	6/21/2006	053-M.Dunn
SET PART ON RISERS WITH DATUM -D- FLANGE DOWN. PLACE A RISER ON EITHER SIDE OF THE POLOIDAL BREAK TO ENABLE CLAMPING TO ENSURE THAT THE DATUMS ARE COPLANER. LAY A STRAIGHT EDGE ACROSS THE DATUM -D- FLANGE TO VERIFY ALIGNMENT. ENSURE RADIAL ALIGNMENT BY LA	65709/2.0 -Sub:1 Op#:130	Closed	6/27/2006	825-B.Jarrett



Activity	Visual Mfg Ref.	Op Status	Close Date	Emp ID
-CMM INSPECT DATUM E SIDE OF CASTING. ---PERFORM ALL HARD GAGING OF THE DATUM E SIDE. ---CONDUCT PERMEABILITY CHECK OF DATUM E SIDE PER OPERATION 136.---CONSULT ENGINEERING ON ANY OUT OF TOLERANCE CONDITIONS PRIOR TO FLIPPING THE PART AND STARTING INSPECT	65709/2.0 -Sub:1 Op#:132	Closed	6/27/2006	339-E.Root
THE -T- AREAS DEFINED AS -HIGH STRESS- ARE TO BE RT 100%. SEE PS581 FOR PROCESS INSTRUCTIONS.---HAND SKETCH A LAYOUT OF ALL FILM LOCATIONS ON ATTACHED RT MAP. ---ALL FILM IS TO BE DOUBLED UP IN ORDER TO SUPPLY THE CUSTOMER WITH A COMPLETE SET OF FILM.---	65709/2.0 -Sub:1 Op#:134	Closed	6/27/2006	010-R.Contractor
PERFORM A MAG PERMEABILITY CHECK OF THE MACHINED SURFACES USING A SEVERN PERMEABILITY INDICATOR GAGE. PERMEABILITY SHOULD BE NO GREATER THAN 1.02μ.---CHECK THE PERMEABILITY IN 3 PLACES ON EACH SIDE OF THE T SECTION AT LOCATIONS ADJACENT TO EVERY 5TH HOLE	65709/2.0 -Sub:1 Op#:136	Closed	6/21/2006	667-J.Bannister
THE RESISTANCE OF THE MID-PLANE ELECTRICAL INSULATION SHALL BE GREATER THAN 500 KOHMS WHEN TESTED AT 100 VDC.---TEST 1:--THE INSULATION RESISTANCE BETWEEN THE MID-PLANE POLOIDAL BREAK SHIM AND WINDING FORM SHALL BE MEASURED. DURING THIS TEST- THE BOLTS S	65709/2.0 -Sub:1 Op#:140	Closed	6/23/2006	840-G.Masood
PERFORM FINAL COSMETICS AS REQUIRED.---THOROUGHLY CLEAN CASTING WITH ISOPROPYL ALCOHOL. VERIFY THAT ALL HOLES ARE CLEAN AND FREE OF CHIPS.	65709/2.0 -Sub:1 Op#:150	Closed	6/27/2006	219-T.Laird
Receive customer supplied material. Part had been returned to vendor for rework.---Part Number: SE141-114 Rev: 5--Part Description: PRODUCTION WINDING FORM TYPE-A	65709/2.0 -Sub:8 Op#:10	Closed	1/21/2006	437-J.Hiatt
SAW MATERIAL TO LENGTH PER MATERIAL CARD.	65709/2.0 -Sub:11 Op#:10	Closed	3/15/2006	266-R.Keith
MACHINE SLAVE HARDWARE BUSHINGS TO THE FOLLOWING:---1.620 O.D.+0/- .002--1.376 I.D. +.004/- .000--LENGTH 1.350 +/- .010---THESE BUSHINGS ARE FOR SLAVE HARDWARE SHIM MOUNTING. DELIVERY THESE PARTS TO RON BACK WHEN COMPLETE. THEY ARE TEMPORARY BUSHINGS THAT	65709/2.0 -Sub:11 Op#:20	Closed	4/13/2006	821-J.Leggins
RECEIVE CUSTOMER SUPPLIED CASTING	65709/2.0 -Sub:2 Op#:10	Closed	1/5/2006	437-J.Hiatt



Activity	Visual Mfg Ref.	Op Status	Close Date	Emp ID
MACHINE THE SHIM COMPLETE PER THE DRAWING AND CNC PROGRAMS.	65709/2.0 -Sub:2 Op#:20	Closed	3/6/2006	744-P.Schumacher
PRE FIT EACH BUSHING TO MAKE SURE THEY SLIP INTO THE POLOIDAL BREAK FLANGE HOLES.--APPLY LOCTITE 411 TO THE OD OF EACH BUSHING AND INSTALL FLUSH TO ONE SIDE OF THE BREAK SHIM. GRIND THE OPPOSITE SIDE OF THE BUSHINGS FLUSH TO THE SHIM.	65709/2.0 -Sub:2 Op#:30	Closed		
SAW OFF 16- AND MOVE TO NEXT WORK CENTER.	65709/2.0 -Sub:3 Op#:10	Closed	6/1/2005	227-D.Bockover
MACHINE OD OF BUSHING .001- - .002- SMALLER THAN SIZE OF THE HOLES IN POLOIDAL BREAK SHIM. IF HOLE SIZES VARY- MARK THE SHIM AND BUSHINGS 1 THRU 7.--MACHINE THE ID OF THE BUSHING TO 1.375- - 1.376--MACHINE THE LENGTH TO 2.19-. BUSHINGS WILL BE GROUND FL	65709/2.0 -Sub:3 Op#:20	Closed	6/20/2006	236-M.Jennings
RECEIVE MATERIAL--NOTIFY CFT AND FORWARD MATERIAL STORES.	65709/2.0 -Sub:4 Op#:10	Closed	6/1/2005	131-W.Allen
SAW OFF 30- LENGTH AND MOVE TO NEXT WORK CENTER.	65709/2.0 -Sub:5 Op#:10	Closed	6/1/2005	227-D.Bockover
MACHINE PER THE DRAWING FOR A .001- - .002- SLIP FIT WITH THE MATING DETAIL. --MEASURE THE HOLE SIZES IN THE TWO CASTING FLANGES AND SIZE THE BUSHINGS ACCORDINGLY. IF THE HOLE SIZES VARY- MARK EACH BUSHING 1 THRU 14 AND MAP OUT THE CORRESPONDING HOLE LOCA	65709/2.0 -Sub:5 Op#:20	Closed	6/20/2006	821-J.Leggins
SAW 13- LENGTH AND MOVE TO NEXT WORK CENTER.	65709/2.0 -Sub:6 Op#:10	Closed	6/1/2005	227-D.Bockover
RECEIVE MATERIAL	65709/2.0 -Sub:7 Op#:10	Closed	4/5/2005	131-W.Allen
MACHINE THE PROFILE LEAVING STOCK PER PROGRAM.	65709/2.0 -Sub:7 Op#:20	Closed	6/1/2006	332-J.Bagwill
SAW PER MATERIAL CARD	65709/2.0 -Sub:9 Op#:10	Closed	2/6/2006	266-R.Keith
SAW PER MATERIAL CARD	65709/2.0 -Sub:10 Op#:10	Closed	2/6/2006	266-R.Keith
RECEIVE HARDWARE- SCAN CERTIFICATIONS AND COMPLETE IDC.--MOVE TO STORES--	65709/2.0 -Sub:12 Op#:10	Closed	5/26/2006	503-B.Houk
PLACE THE FOLLOWING IN STORES:--7 PCS - DS141-036 STUD--14 PCS - DS141-060 NUT	65709/2.0 -Sub:12 Op#:20	Closed	5/26/2006	419-J.Smith
MACHINE THICKNESS OF SHIM TO 2.125 +/- .001--REMOVE AN EVEN AMOUNT OF STOCK FROM EACH FACE OF THE SHIM. THERE IS APPROXIMATELY 1/16- PER SIDE OF STOCK ON THE PART.	65709/2.0 -Sub:13 Op#:10	Closed	6/22/2006	332-J.Bagwill



Activity	Visual Mfg Ref.	Op Status	Close Date	Emp ID
NO CERTIFICATIONS REQUIRED.--VERIFY QUANTITY AND FORWARD PARTS TO NEXT WORK CENTER.	65709/2.0 -Sub:14 Op#:10	Closed	5/12/2006	437-J.Hiatt
MACHINE COMPLETE PER PRINT	65709/2.0 -Sub:14 Op#:20	Closed	6/19/2006	506-R.Liston
PERFORM A MAGNETIC PERMEABILITY CHECK USING A SEVERN PERMEABILITY INDICATOR GAGE. PERMEABILITY SHOULD BE NO GREATER THAN 1.02μ.--Part Number: SE141-141--Part Description: BEARING PLATE TYPE -A- SHORT	65709/2.0 -Sub:14 Op#:30	Closed	6/20/2006	503-B.Houk
NO CERTIFICATIONS REQUIRED.--VERIFY QUANTITY AND FORWARD PARTS TO NEXT WORK CENTER.	65709/2.0 -Sub:15 Op#:10	Closed	5/12/2006	437-J.Hiatt
MACHINE COMPLETE PER PRINT	65709/2.0 -Sub:15 Op#:20	Closed	6/19/2006	234-E.Booher
PERFORM A MAGNETIC PERMEABILITY CHECK USING A SEVERN PERMEABILITY INDICATOR GAGE. PERMEABILITY SHOULD BE NO GREATER THAN 1.02μ.--Part Number: SE141-142--Part Description: BEARING PLATE TYPE -A- LONG	65709/2.0 -Sub:15 Op#:30	Closed	6/20/2006	503-B.Houk

Customer: ENERGY INDUSTRIES OF OHIO

Contact: NANCY HORTON
E-Mail: NKHFlowen@aol.com

Telephone: 216-496-2314
Fax: 216-328-2001

Part: SE141-114 / MODULAR COIL WINDING FORM TYPE
Drawing ID: SE141-114 Revision: 6

Customer P.O.: S005242-F/Ln:2
Serial No./Qty: A2

Reported By: MIKE GRIFFITH
E-Mail: mGriffith@MajorTool.com

Telephone: 317-636-6433
Fax: 317-634-9420

Problem: PART IS REJECTED PER ASTM A903/A903M LEVEL 1.
SEE ATTACHMENT FOR SIZES AND LOCATIONS.

Proposed Disposition:

PROPOSE TO USE AS IS.

Number of additional pages: 8 page attachment

Customer Disposition: Use As Is Rework Repair Scrap Replace

The indications were reviewed by David Williamson (see below). Since all but one small cluster was in a low stress area, they are accepted "use as is".

From: "Williamson, David E." <williamsonde@ornl.gov>

Date: June 23, 2006 9:57:52 AM EDT

To: "Frank A. Malinowski" <fmalinow@pppl.gov>, "Nelson, Brad E." <nelsonbe@ornl.gov>, Phil Heitzenroeder <pheitzen@pppl.gov>

Cc: "Colin F. Phelps" <cphelps@pppl.gov>

Subject: RE: A2 PT rejections

Phil, Frank,

There are four PT indications on the winding surface (#2, 4, 5, 17), but only one small cluster in the high stress region (#4). I would recommend that we accept the part as-is.

Thanks,
David

Approved by:

Phil
Heitzenroeder

Digitally signed by Phil Heitzenroeder
DN: cn=Phil Heitzenroeder, c=US, o=PPPL, ou=Mech. Eng. Division
Reason: I am approving this document
Date: 2006.06.27 22:44:11 -04'00'

Brad
Nelson

Digitally signed by Brad Nelson
DN: cn=Brad Nelson, c=US, o=ORNL, ou=FED, email=nelsonbe@ornl.gov
Date: 2006.06.28 09:34:46 -04'00'

Tech. Rep.

RLM

Major Tool Implemented By:

Mike
Griffith

Digitally signed by Mike Griffith
DN: cn=Mike Griffith, c=US, o=Major Tool and Machine, ou=CT - White, email=mgriffith@majortool.com
Reason: I agree to the terms defined by the placement of my signature on this document
Date: 2006.06.29 15:16:23 -04'00'

Title:

Date:

n:\mtmapps\MInonc14.qpp

PT Inspection Results of A2 – NC20044

1. Linear cluster, longest is .550". Reference cutout on drawing sheet 5, zone C6.

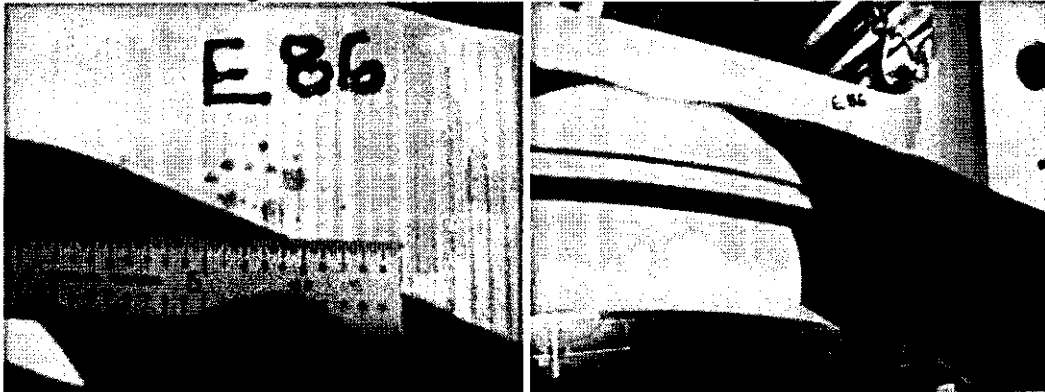

2. Linear indication, .150" long. Located on E side short leg near hole 78.

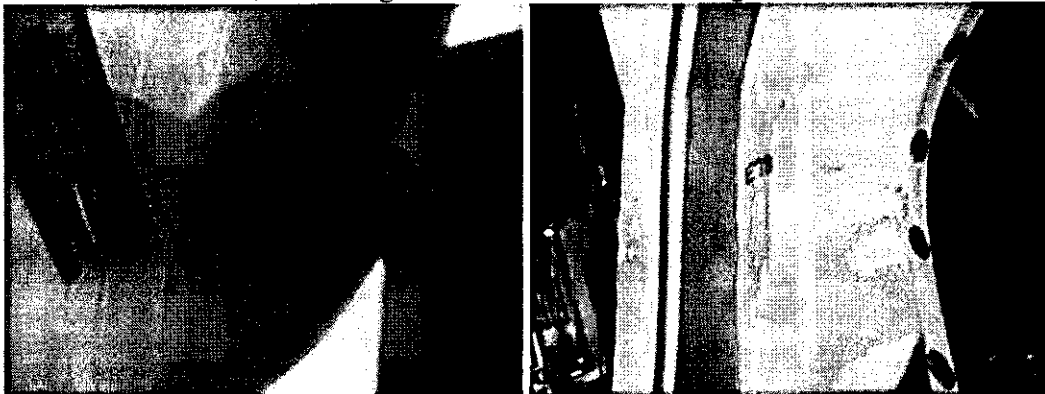

3. .600" long linear located on E side of inner cast wall. This area has been machined due to excess cast stock. Reference sheet 5, zone E5.

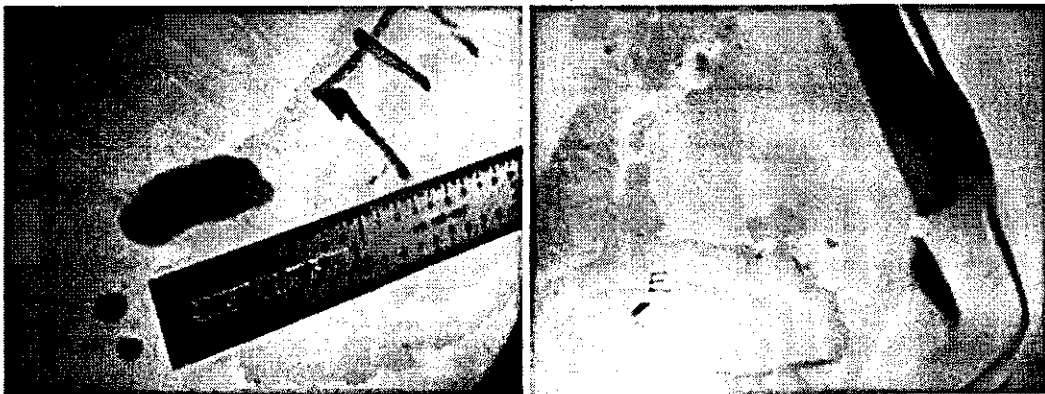

PT Inspection Results of A2 – NC20044

4. Linear cluster, longest is .300". Located on long leg of E side near hole 43.

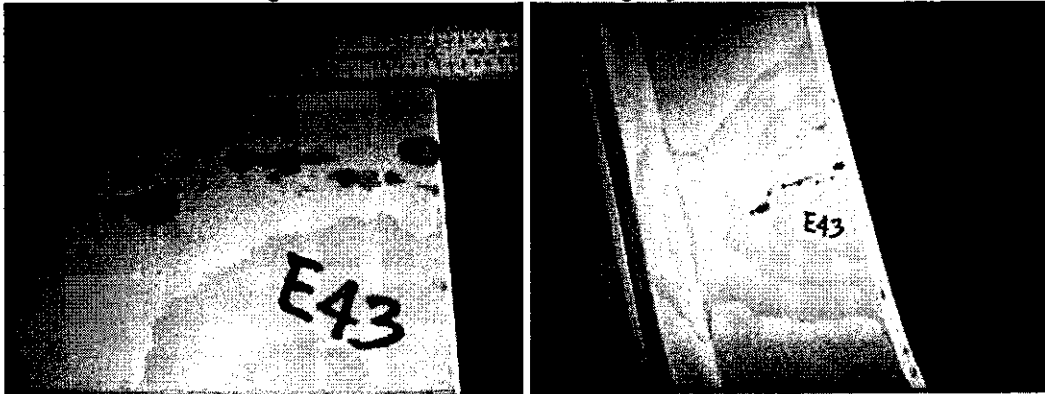

5. Linear cluster approximately .550" long, located on long leg of E side near hole 28.

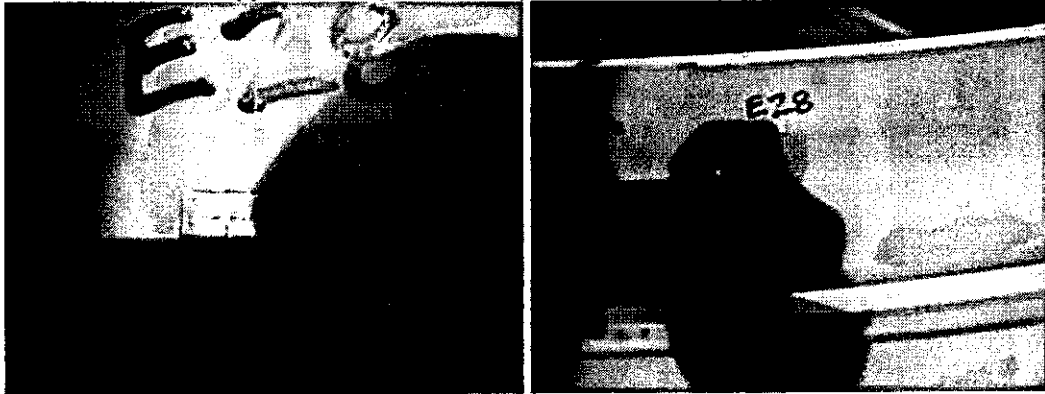

6. .350" linear located in VPI groove near hole 28 on E side.

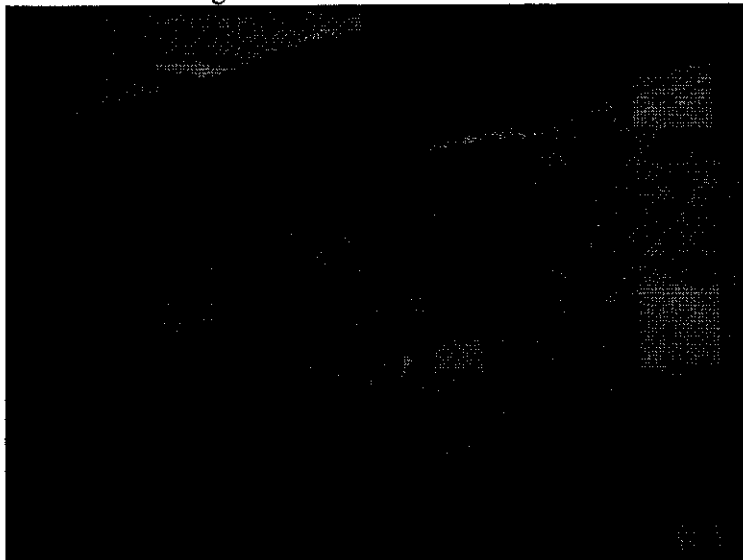

PT Inspection Results of A2 – NC20044

7. Linear indications in 1.885 thru hole in datum E flange. Longest is .200"

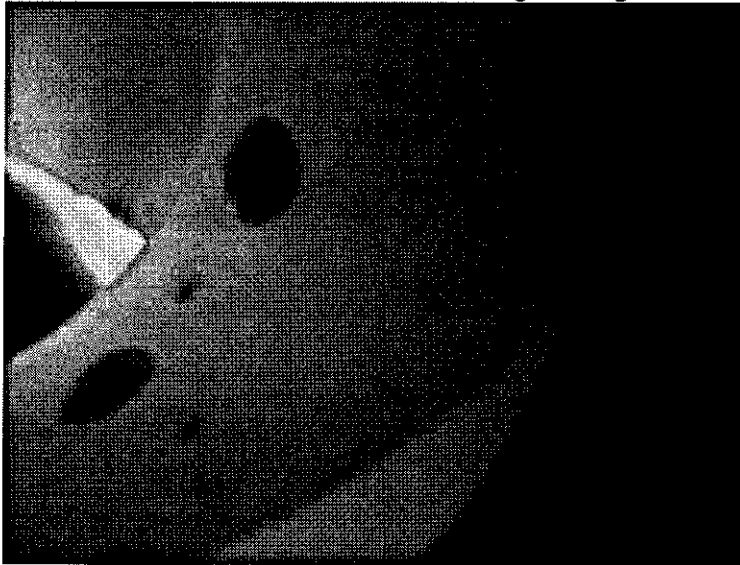

The picture below is a wide view of indications 5, 6 and 7. All of the indications are grouped in the same general area.

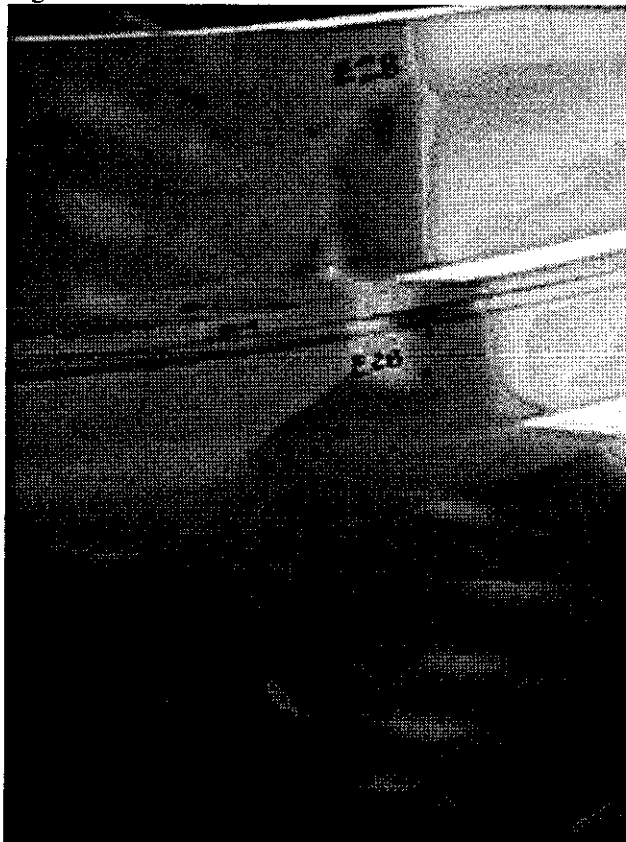

Mike Griffith

Page 3 of 8

6/22/2006



PT Inspection Results of A2 – NC20044

8. .200 long linear indication on E side near hole 25 and between the two 1" holes.

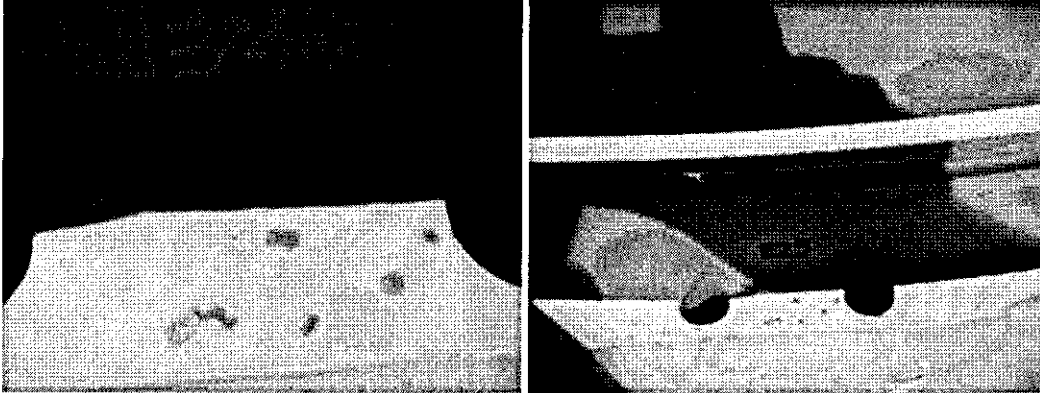

9. .500" long linear indication in the 2.0" diameter hole on D flange near hole 80.



10. .200" long linear on D flange face near hole 80. This picture shows a wide view of indications 9, 10 & 11.

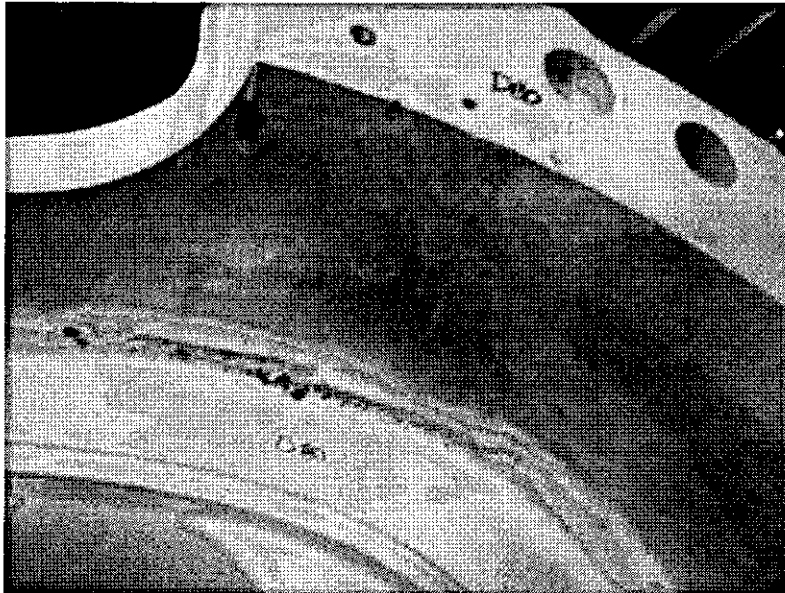

Mike Griffith

Page 4 of 8

6/22/2006

PT Inspection Results of A2 – NC20044

11. Cluster of indications below VPI groove on D side of casting. Cluster is in area near hole 80. The largest indication is approximately .800" long.

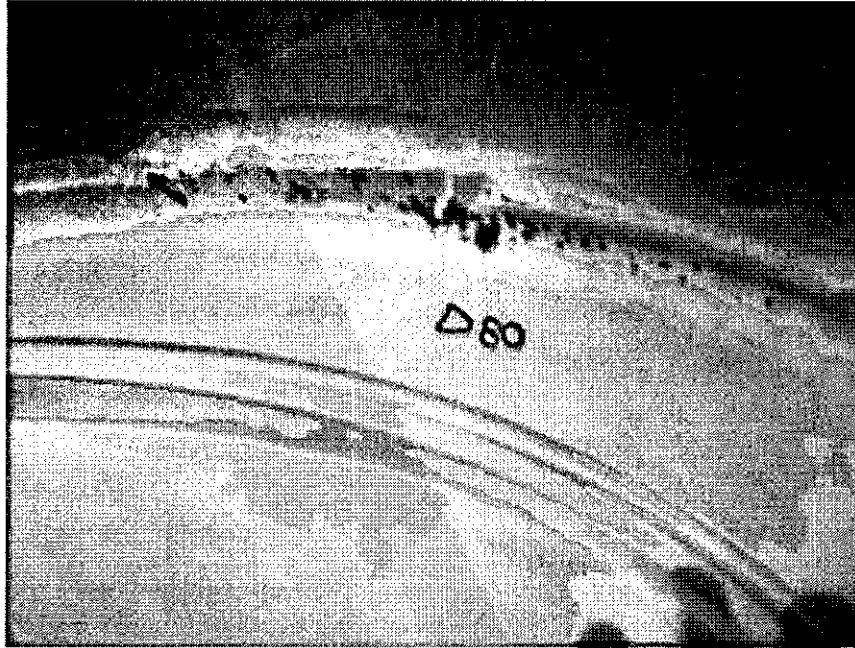

12. The following photos show indications on the outer edge of the D flange (labeled D1 thru D3).

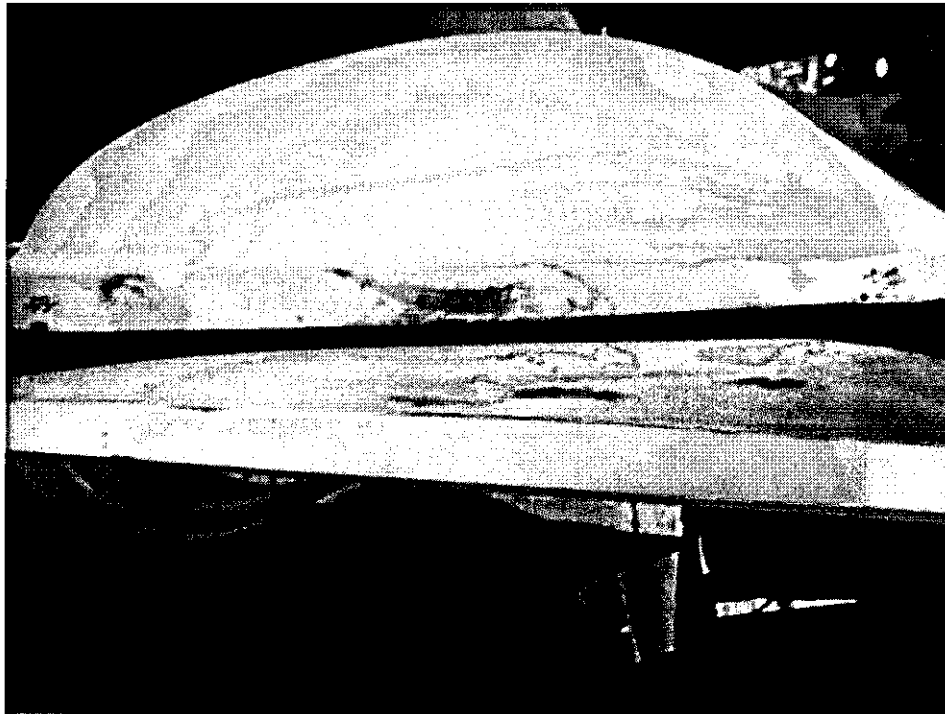

PT Inspection Results of A2 – NC20044

D1 = linear cluster, longest is .800".

D2 = rounded indication, .100".

D3 = linear, approximately 1.3" long.

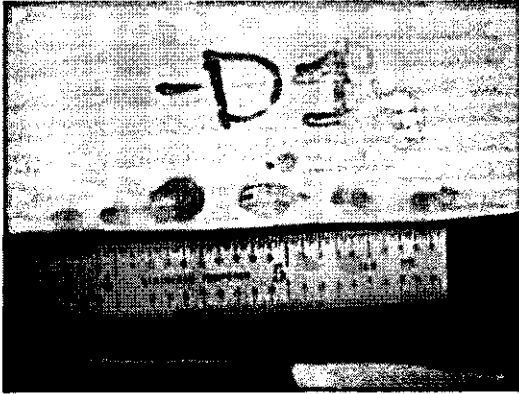

13. Rounded indication, approximately .150" located in large cut out of D flange near hole 5.



PT Inspection Results of A2 – NC20044

14. Rounded indication, approximately .125" located in large cut out of D flange near hole 15.

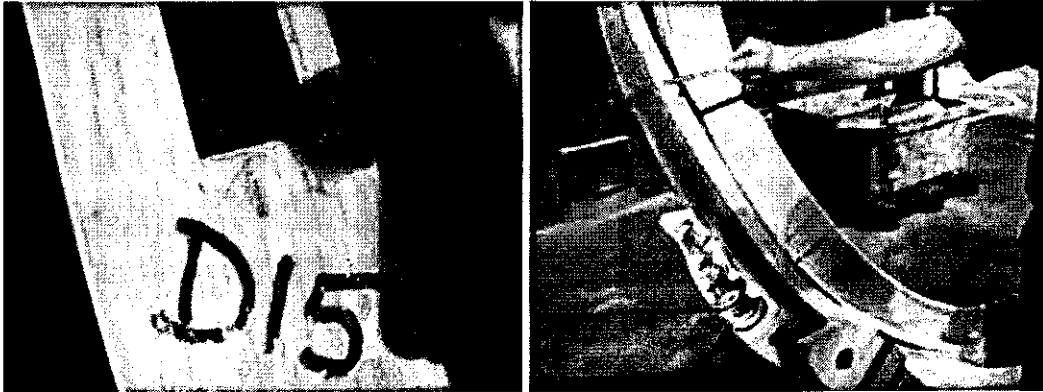

15. Cluster of linear indications in large cut out. Largest is a .600". Reference sheet 4, zone G6.



16. Cluster of linear indications near 2" diameter bore on D flange near hole 27. Picture at the bottom right shows indications for both 15 and 16.

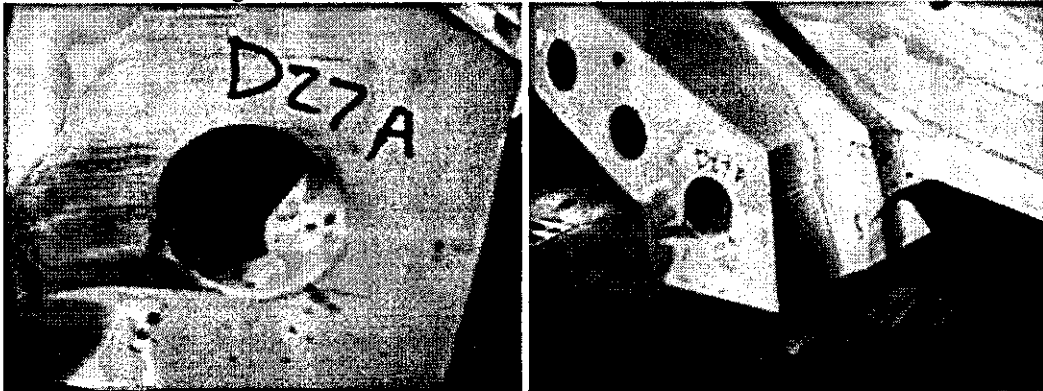

PT Inspection Results of A2 – NC20044

17. Linear indication approximately .140" long on long leg of T near hole 28 on D side.

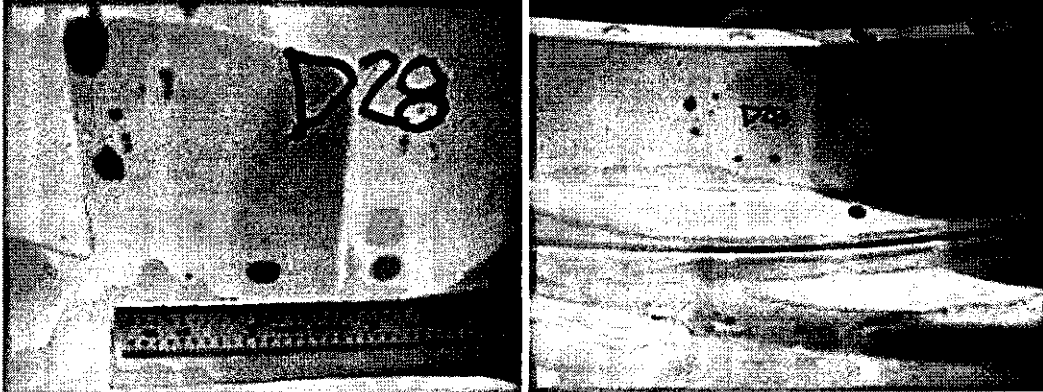

A2 PT INDICATIONS

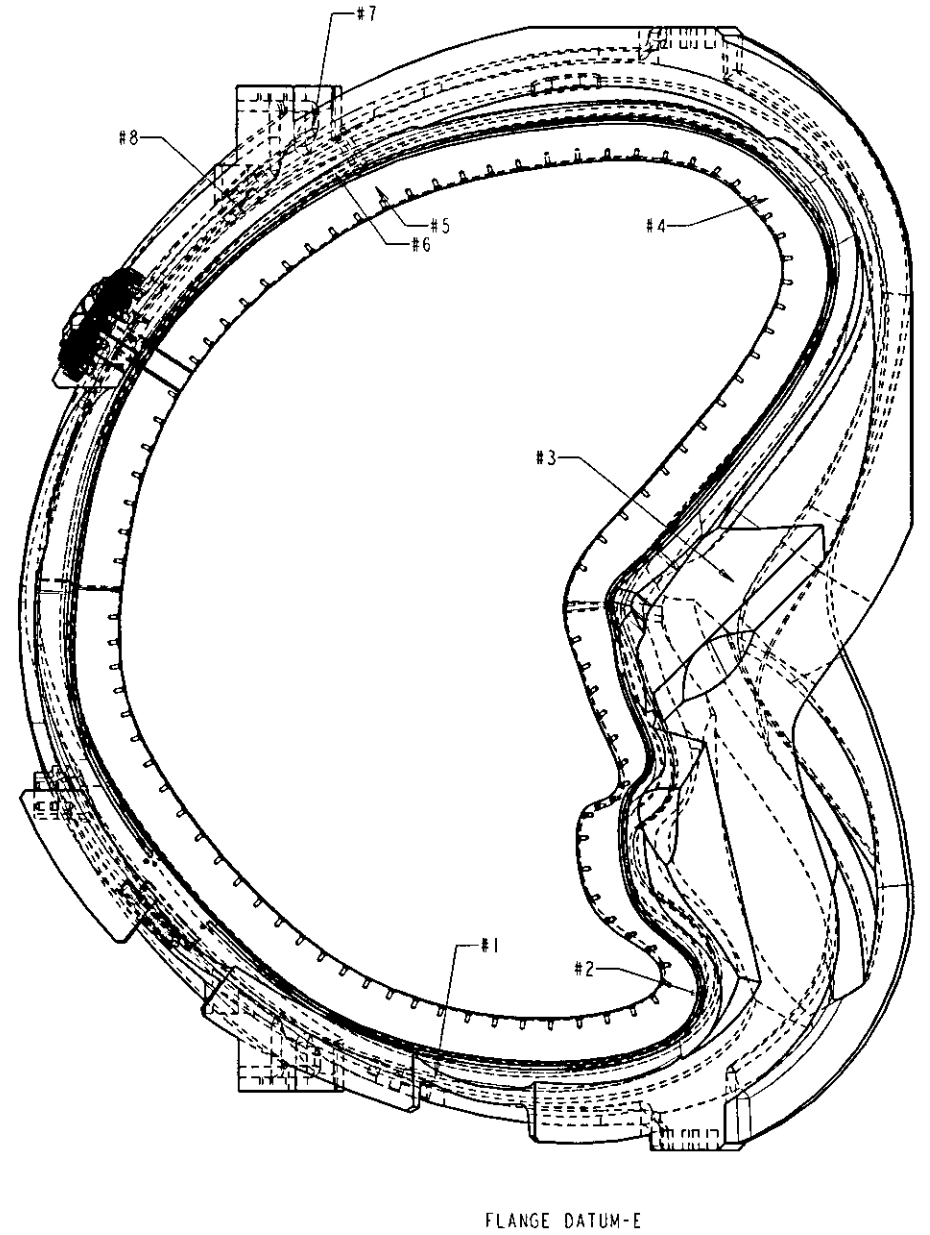
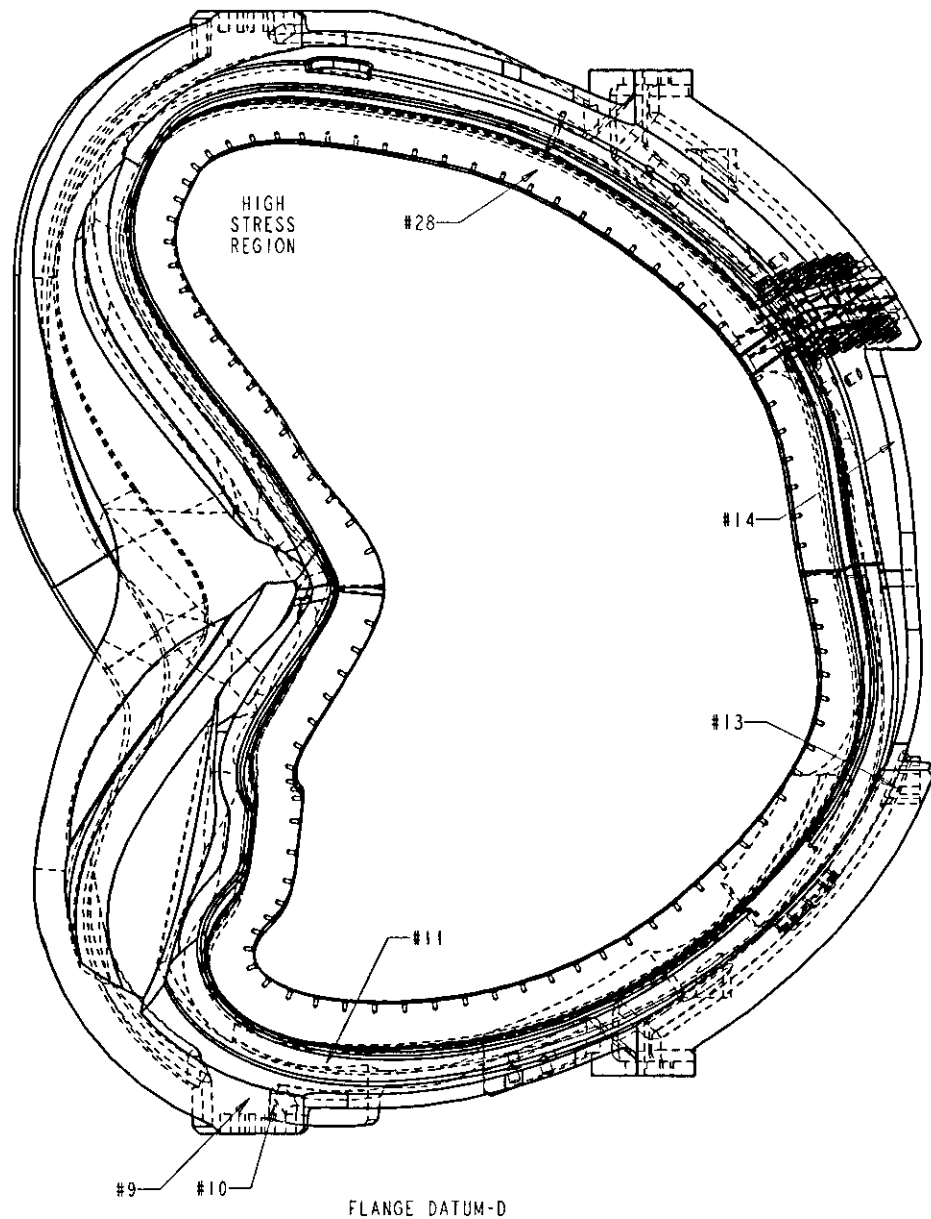

Customer: ENERGY INDUSTRIES OF OHIO

Contact: NANCY HORTON
E-Mail: NKHFlowen@aol.com

Telephone: 216-496-2314
Fax: 216-328-2001

Part: /

Drawing ID: SE141-114

Revision: 7

Customer P.O.: S005242-F/Ln:2
Serial No./Qty: 1

Reported By: MIKE GRIFFITH
E-Mail: mGriffith@MajorTool.com

Telephone: 317-636-6433
Fax: 317-634-9420

Problem: Inspection Test #: 130 rejected: OUTER AS CAST SURFACES: {g,5|A|B|C}: -.092 TO .553
Inspection Test #: 140 rejected: 2 X .40: : .395 TO .435 ON E SIDE, .355 TO .410 ON D SIDE
Inspection Test #: 150 rejected: 4 X .03 X 45: : .035 ON E SIDE, .010 TO .035 ON D SIDE
Inspection Test #: 180 rejected: DATUM D SIDE

VERIFY SHELL INTERSECT CLEARANCE WITH GAGE MTMFX-3473: : REJECT - MODEL DOES NOT ALLOW FOR CLEARANCE

Inspection Test #: 190 rejected: M TO M1: {g,02|R|T|S}: -.021 TO .012

Inspection Test #: 230 rejected: N TO N1: {g,02|R|T|S}: -.017 TO .027

Inspection Test #: 240 rejected: 2 X .06/.09 X 45: : .025 TO .050

Inspection Test #: 260 rejected: : bd.625 y .188: .618 TO .627 DEPTH .165 TO .193

Inspection Test #: 280 rejected: DATUM E FLANGE: {f,01}: .015

Inspection Test #: 290 rejected: DATUM D FLANGE: {f,01}: .032

Inspection Test #: 330 rejected: 8X Ø1-8 UNC: {#,010|A|B|C}: .016 TO .060

Inspection Test #: 350 rejected: 8X Ø1-8 UNC: {d,010|A|B|C}: .016 TO .066

Inspection Test #: 460 rejected: : 6X .25-20 UNC y .5

.5 X 82' CHAMFER: THE THREADS ARE ACCEPTABLE BUT THE CHAMFER IS TOO BIG .500

Inspection Test #: 480 rejected: Ø1.885: {#,06|N|A|E}: .003 TO .074

Inspection Test #: 540 rejected: : 6X .25 - 20 UNC y .6

d.5 X 82' CHAMFER: .375 DIA. CHAMFER

Inspection Test #: 780 rejected: INNER AS CAST SURFACES: {g,5|A|B|C}: -.034 TO -.337 / -.341 TO .073

Inspection Test #: 790 rejected: WING SURFACES: {g-,12;;,25|A|B|C}: -.164 TO -.197 / -.016 TO -.206

Additional Items:

- 1) Tool Gouge on top edge of T, datum D side. Gouge is approximately .300" long and .015" in depth. See pictures.
- 2) G11 shim is below flush on the outer surface of the datum D flange. G11 is approximately .08" below flange surface. See pictures.
- 3) Tool marks did not clean up on the short leg of the D flange from holes 16 to 19. Tool marks appear to be less than .005" in depth. See pictures.

Proposed Disposition:

Propose to accept deviations As-Is.

Number of additional pages: Dimensional IDC and Final Visual Pictures

Customer Disposition: Use As Is Rework Repair Scrap Replace

n:\ntmapps\Mtnonc14.qrp

Nonconformance Report: NC 20080

A-2 dimensional deviations and surface discontinuities.

Project Disposition:

All deviations and discontinuities were evaluated and reviewed by NCSX in a teleconference on 6/28/06. All were determined to be acceptable as-is.

Approvals:

**Larry
Dudek**

Digitally signed by Larry
Dudek

DN: cn=Larry Dudek, c=US
Date: 2006.06.28 10:45:00
-04'00'

Procurement Technical Representative

Brad Nelson

Digitally signed by Brad Nelson

DN: cn=Brad Nelson, c=US,

o=ORNL, ou=FED,

email=nelsonbe@ornl.gov

Date: 2006.06.28 13:30:32 -04'00'

Responsible Line Manager:

Major Tool Implemented By: **Mike Griffith**

Digitally signed by Mike Griffith
DN: cn=Mike Griffith, c=US, o=Major Tool
and Machine, ou=JIT - White
email=mgriffith@majortool.com
Reason: I agree to the terms defined by the
placement of my signature on this
document.
Date: 2006.06.22 08:23:47 -04'00'

Title: _____ Date: _____

SE141-114 A2
NC20080 attachment

1. Tool gouge on top edge of T section on the datum D side of the part. Gouge is near hole 76.

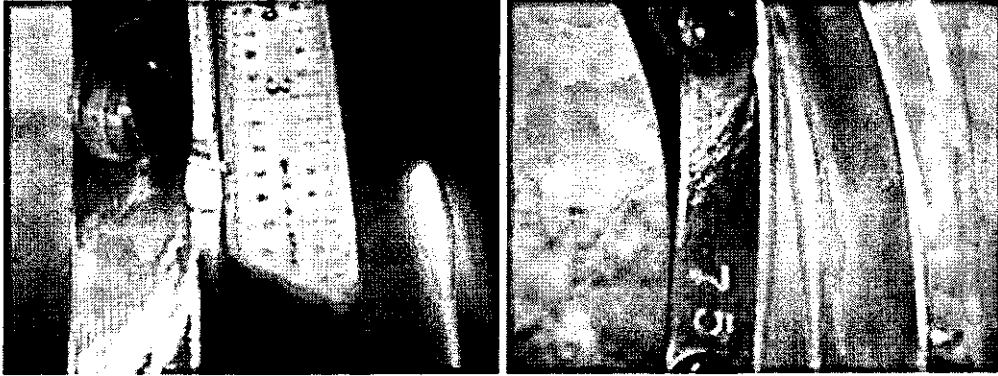

2. G11 shim is below flush on the outer surface of the datum D flange. G11 is approximately .08" below flange surface.

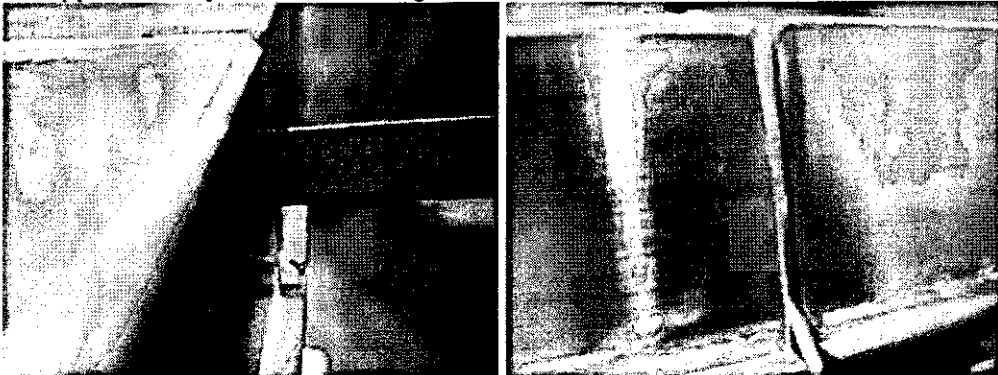

3. Tool marks did not clean up on the short leg of the D flange from holes 16 to 19. Tool marks appear to be less than .005" in depth. See pictures.

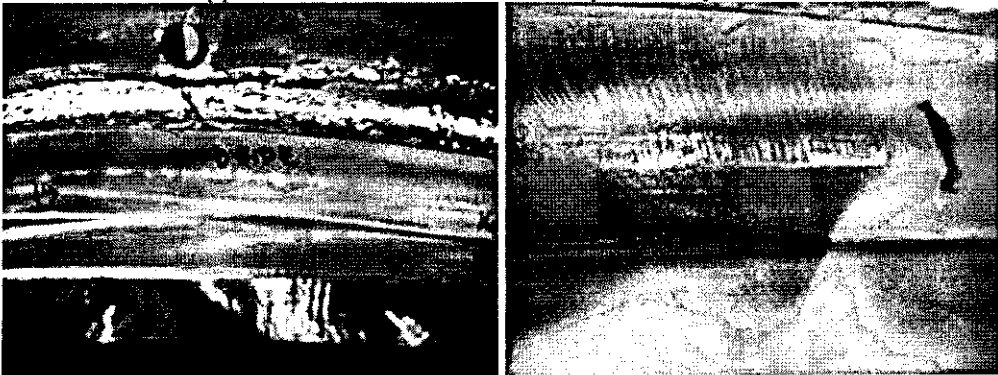

MAJOR TOOL & MACHINE INC 1458 E 19TH ST INDIANAPOLIS IN 46218		YOUR PURCHASE ORDER NUMBER P05-01332 Today's Date:		MCMASTER-CARR 600 COUNTY LINE ROAD ELMHURST IL 60126-2001 IF THERE ARE ANY QUESTIONS ABOUT THIS SHIPMENT CONTACT OUR SALES DEPARTMENT (630)833-0300		PAGE 1 (MORE) MCM NUMBER 6241663-02	
Warehouse Location	McMaster Carr Part Number	FBI Quantity	Item Description	Your Line	Your Order	This Shipment	
PACKING LIST EXTRA	74765 A86	1 EA	LOCTITE PRISM SUPER GLUE TOUGHENED, NUMBER 411, 1-POUND BOTTLE, CLEAR HZ-N 1	5	1 EA	1	
	74765 A86	1 EA	LOCTITE PRISM SUPER GLUE TOUGHENED, NUMBER 411, 1-POUND BOTTLE, CLEAR HZ-N 1	6	1 EA	1	
	74765 A86	1 EA	LOCTITE PRISM SUPER GLUE TOUGHENED, NUMBER 411, 1-POUND BOTTLE, CLEAR HZ-N 1	7	1 EA	1	
	74765 A86	1 EA	LOCTITE PRISM SUPER GLUE TOUGHENED, NUMBER 411, 1-POUND BOTTLE, CLEAR HZ-N 1	8	1 EA	1	
	74765 A86	0 EA	LOCTITE PRISM SUPER GLUE TOUGHENED, NUMBER 411, 1-POUND BOTTLE, CLEAR HZ-N Balance of 1 EA expected to ship by 3/9/2005	9	1 EA	0	
	74765 A86	0 EA	LOCTITE PRISM SUPER GLUE TOUGHENED, NUMBER 411, 1-POUND BOTTLE, CLEAR HZ-N Balance of 1 EA expected to ship by 3/9/2005	10	1 EA	0	
	74765 A86	0 EA	LOCTITE PRISM SUPER GLUE TOUGHENED, NUMBER 411, 1-POUND BOTTLE, CLEAR HZ-N Balance of 1 EA expected to ship by 3/9/2005	11	1 EA	0	

REFER TO: 6241663-02
 MAJOR TOOL & MACHINE INC

TAG
 CCP

MTM 09

3/10/05

3/10/05

94115

Lines 5-8

PACKER	Number of CARTONS	FILLER

LNS: 7

CYCLE

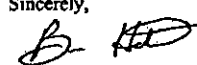
<p>CERTIFICATION OF COMPLIANCE</p> <p>This is to certify that, according to our records, the above item(s) furnished on your purchase order was supplied in accordance with the description and as illustrated in our catalog.</p> <p>Sincerely,  Brian Hedstrom Quality Manager</p>	<p>MCM NO. 6241663-02 04</p> <p>PURCHASE ORDER P05-01332</p> <p>FROM: MCMASTER-CARR 600 COUNTY LINE ROAD ELMHURST IL 60126-2001 USA</p> <p>SHIP TO: MAJOR TOOL & MACHINE INC 1458 E 19TH ST INDIANAPOLIS IN 46218</p> <p>CCP</p>
---	--

X



Shipping List 072435
Customer No 101193
Sales Order Shipper

Sold to : STANDARD GRINDING & MFG CO
3721 W. CHASE AVENUE
SKOKIE, IL 60076
United States

Ship to : STANDARD GRINDING & MFG CO
3721 W. CHASE AVENUE
SKOKIE, IL 60076
United States

Ship Date	Customer PO	Sales Order	# of Boxes	Weight	Ship VIA	Bill of Lading	FOB
05/17/2005	60624	085171-08	1	0	YELLOW	072435	DE
Item	Part / Description / Details				Order Qty	Ship Qty	
000001	39G1CNT73125NMWLF U/M SHT SO Item 4 G-11-CR 48" +/-untrimmed X 36" +/-untrimmed Thickness: 3.125" +/- .110" PLEASE NOTE THAT THERE IS NO NEMA STANDARD FOR G-11 CR SHEET SPAULDING C OF C TO G-11 CR SHEET NO TESTING REQUIRED AT TIME OF ORDER <i>Sheet feet 3,500 TC</i>				1.00000	10000	

CERTIFICATE of CONFORMANCE

WE HEREBY CERTIFY THAT THE MATERIAL SUPPLIED ON THIS ORDER WAS MADE IN ACCORDANCE WITH THE STANDARDS AND PROCESSES ESTABLISHED BY SPAULDING COMPOSITES COMPANY FOR THE REQUIREMENTS OF MATERIAL DESCRIBED ABOVE.

LOT # _____ DOML _____
Authorized By: Mark J. Candillo Date: 05/17/2005

Customer Copy Page # 1 Form: 3CSHIP Rev: 8/99

000/200 ATLAS FIBRE CO. 05/26/05 13:00 002/003



Spaulding
COMPOSITES

55 Nadeau Drive
Rochester, NH 03867
Ph: (603) 332-0555 Fax: (603) 332-5957
www.spaulding.com.com

Shipping List 072434

Customer No 101193
Sales Order Shipper

Sold to : STANDARD GRINDING & MFG CO
3721 W. CHASE AVENUE
SKOKIE, IL 60076
United States

Ship to : STANDARD GRINDING & MFG CO
3721 W. CHASE AVENUE
SKOKIE, IL 60076
United States

Ship Date	Customer PO	Sales Order	# of Boxes	Weight	SNP VIA	Bill of Lading	FOB
05/17/2005	60824	065163-00	1	716	YELLOW	072434	DE
Item	Part / Description / Details				Order Qty	Ship Qty	
000001	39G1CNT71650NMWLF U/M SHT SO Item 5 G-11 CR 48" *UNTRIMMED X 36" *UNTRIMMED THK: 1.850" +/- .070" PLEASE NOTE THAT THERE IS NO NEMA STANDARD FOR G-11 CR SHEET SPAULDING C OF C TO G-11 CR SHEET NO TESTING REQUIRED AT TIME OF ORDER				1.00000	1.00000	
					5/31/05 		

CERTIFICATE of CONFORMANCE

WE HEREBY CERTIFY THAT THE MATERIAL SUPPLIED ON THIS ORDER WAS MADE IN ACCORDANCE WITH THE STANDARDS AND PROCESSES ESTABLISHED BY SPAULDING COMPOSITES COMPANY FOR THE REQUIREMENTS OF MATERIAL DESCRIBED ABOVE.

LOT # _____ DOM.
Authorized By: Mark A. Cardillo Date: 05/17/2005

INSPECTION DATA CHECKLIST

Quality Assurance Documentation for Part ID: SE141-101 - Item: 7

Workorder: 65709/2-0 Sub:1 Op:140

Part: SE141-101 - MODULAR COIL WINDING FORM TYPE-A - PRODUCTION MODULAR COIL WINDING FORM TYPE-A

Drawing ID: SE141-101 Rev: 3			INSPECTION INSTRUCTIONS			RESULTS		INSPECTED BY			
SHEET	ZONE	CHARACTERISTIC	GAGE/EQUIP	BY	SAMPLE	SER#	DATA/REMARKS	INSP	VERFD	AUDIT	
*		<u>TEST 1</u> RESISTANCE TO BE >500 kohms CHECK RESISTANCE BETWEEN THE MID-PLANE POLOIDAL BREAK SHIM AND THE WINDING FORM.	MULTIMETER	QA		J-1358	MEASURED AT 2.2 GIG AOHMS	840-G.M			A
(10)								06-23-06			
*		<u>TEST 2</u> RESISTANCE TO BE >500 kohms CHECK RESISTANCE BETWEEN THE JUMPERED BOLTS AND JUMPERED MID-PLANE CASTING AND WINDING FORM.	MULTIMETER	QA		J-1358	MEASURE AT 33 TO 40 MEGA OHMS	840-G.M			A
(20)								06-23-06			

METRODE PRODUCTS LTD
 HANWORTH LANE
 CHERTSEY SURREY
 ENGLAND KT16 9LL
 Tel: +44 (0)1932 566721
 Fax: +44 (0)1932 565168
 Email: info@metrode.com
 Internet: http://www.metrode.com



TEST CERTIFICATE

THIS PRODUCT HAS BEEN MANUFACTURED
 AND SUPPLIED THROUGH A SYSTEM APPROVED
 TO ISO 9001 & 2 OR EQUIVALENT



TEST CERTIFICATE NUMBER 194277

INVOICE TO
EUROWELD LTD 255 ROLLING HILLS ROAD MOORESVILLE NC 28117 USA

DESPATCHED TO
EUROWELD LTD 255 ROLLING HILLS ROAD MOORESVILLE NC 28117 USA

BATCH No.	W020132
OUR ORDER REF.	S01708013 / 1
DATE	09/03/05
PRODUCT	ER316MNNF TIG 2.4MM
FORM	TIG WIRE
SPECIFICATION	BS EN 12072:2000 W 20 16 3 Mn L

IMPORTANT: Any liability arising from either reliance on this certificate, or use of our products, is strictly limited and governed by our conditions of business.

CUSTOMER ORDER No.
N. 05-39

DELIVERY NOTE DOCUMENT No.
DN0106163

QUANTITY (Kg)
17.500G

CHEMICAL ANALYSIS (WEIGHT %)				TYPE CERTIFIED MATERIAL TEST REPORT: BS EN 10204: 3.1.B											
C	Mn	Si	S	P	Cr	Ni	Mo	N	Cu						
0.015	7.43	0.42	0.006	0.014	19.9	15.4	2.62	0.14	0.20						

TYPICAL ALL-WELD METAL MECH. PROPERTIES, AS WELDED:- TS: >600 N/mm ² ; 0.2%PS: >400 N/mm ² ; EL. ON 4D: 40 %; CVN @ -196 DEG.C: 70 J.
3/23/05 44534 Line 1 B-2 

Metrode Products Ltd. certifies that the above material conforms to the indicated specifications
 B. KYIET QA MANAGER

NOTES: *J₁₅ includes incidental Co unless otherwise specified
 *J₁₅ (Cb) includes incidental Ta unless otherwise specified
 Ferrite is given as FN (Ferrite Number) and measured on all-welds paid using instrument calibrated against NBS related secondary standards (See AWS A4 2-97) unless otherwise specified

All Test certificates issued by METRODE will contain this embossed seal
 Any recipient of a copy of METRODE Test Certificate without the seal should ensure from the supplier that it is a true and accurate reproduction of the original

mc106579.tif (1652x2103x2 bit)

METRODE PRODUCTS LIMITED
HANWORTH LANE, CHERTSEY

SURREY, UK, KT16 9LL

Tel: +44 (0) 1832 566721

Fax: +44 (0) 1832 565188

Email: info@metrode.com

Website: www.metrode.com

**CERTIFIED MATERIAL
TEST REPORT**



THIS PRODUCT HAS BEEN MANUFACTURED
AND SUPPLIED THROUGH A SYSTEM
APPROVED TO ISO 9001 & 2 OR EQUIVALENT



TEST CERTIFICATE NUMBER

193695

INVOICE TO
EUROWELD LTD
255 ROLLING HILLS ROAD
MOORESVILLE
NC 28117
USA

DESPATCHED TO
EUROWELD LTD
255 ROLLING HILLS ROAD
MOORESVILLE
NC 28117
USA

CUSTOMER ORDER NUMBER	N.05-34
DELIVERY NOTE DOCUMENT NUMBER	DN0105859
QUANTITY (KG)	15.0000
OUR ORDER REFERENCE	SO1787730 / 1
DATE	02/03/05

METRODE WELDING CONSUMABLE	ER316MNNF TIG 2.4mm
FORM	TIG WIRE
BATCH NUMBER	W020132
SPECIFICATION	BS EN 12072:2000 W 20 18 3 Mn L

Chemical Analysis (Weight %)										Type: BS EN 10204: 3.1.B / ASME SFA-5.01: Sch. H	
C	Mn	Si	S	P	Cr	Ni	Mo	N	Cu		
0.015	7.43	0.42	0.006	0.014	19.9	15.4	2.62	0.14	0.20		

Mechanical Tests Type: BS EN 10204: 2.2 / ASME SFA-5.01: Sch. G

Tensile Tests						Impact Energies		
Condition	Test Temperature	R _{p0.2} (MPa)	R _m (MPa)	A ₄ (%)	Z (%)	Temperature (°C)	Impact Energy (J)	Lateral Expansion (mm)
AS-WELDED	ROOM	>400	>600	40	-	-195	70	-

Metrode Products Limited certifies that the above material conforms to the included specifications.

This document is produced electronically and is valid without signature.

IMPORTANT Any liability arising from other reference to this certificate, or use of our products, is strictly limited and governed by our conditions of business.

Barrie Kyle - Q.A. Manager

ASME SFA-5.01; Lot classification S4

3/3/05
93911
Line 1 B.2

Notes:
1. An includes incidental to unless otherwise specified.
2. An (C) includes (included) to unless otherwise specified.
Partic is given as FN (partic number) and measured on all-welded part using instrument calibrated against NBS-related secondary standards (see ASTM A2-97) unless otherwise specified.

MTH
G9
3/7/05

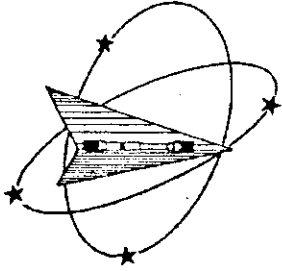

Westmoreland Mechanical Testing & Research, Inc.

P.O. Box 388

Westmoreland Drive

Youngstown, Pa. 15696-0388 U.S.A.

Telephone: 724-537-3131 Fax: 724-537-3151

Website: www.wmtr.com

WMT&R is a technical leader in the material testing industry.



621-01 & 621-02

April 22, 2005

CERTIFICATION

Major Tool & Machine Inc.
1458 East 19th Street
Indianapolis, IN 46218

Corrected Date
May 4, 2005

Page IM1 of 1

WMT&R Report No. 5-25008
P.O. No. P05-01764
PQR No. 434
Welder Jason Bever #465

Attention: Josh Mayne

Subject: All processes, performed upon the material as received, were conducted at WMT&R, Inc. in accordance with the WMT&R Quality Assurance Manual, Rev. 9, dated 4/1/2000.
The following tests were performed on this order: IMPACT and TENSILE

IMPACT RESULTS: ASME Section IX and AWS B2.1, ASTM E23-02

No Requirements

MATERIAL: Metaltek CF8MNMN MOD

SAMPLE TYPE: Charpy V-Notch

DISPOSITION: Report

Specimen ID	TestLog Number	Sample Size	Temp. °F/°C	Energy ft-lbs	Energy joules	Mils Lat Exp	A/U/R
Weld-1	B65835	Standard	68/20	173	234.6	84	Report
Weld-2	B65836	Standard	68/20	160	216.9	68	Report
Weld-3	B65837	Standard	68/20	157	212.9	81	Report

A/U/R: A=ACCEPTABLE, U=UNACCEPTABLE, R=REPORT

KNOWINGLY OR WILLFULLY FALSIFYING OR CONCEALING A MATERIAL FACT ON THIS FORM OR MAKING FALSE, FICTITIOUS OR FRAUDULENT STATEMENTS OR REPRESENTATIONS HEREIN COULD CONSTITUTE A FELONY PUNISHABLE UNDER FEDERAL STATUTES. THIS CERTIFICATE OR REPORT SHALL NOT BE REPRODUCED EXCEPT IN FULL, WITHOUT THE WRITTEN APPROVAL OF WMT&R, INC.

Richard G. Parks
Project Manager/Industrial Technology Engineer

5/4/05
May 4, 2005

Testing Specialists for Aerospace, Automotive, and Material Testing Fields
Locations in Youngstown, PA U.S. 95 - Tel. (724) 537-3131 and
Banbury U.K. - Tel. +44 (0) 1295 261211

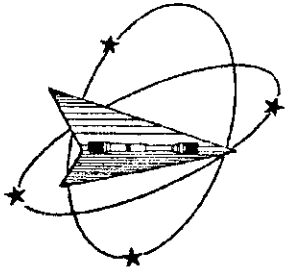

Westmoreland Mechanical Testing & Research, Inc.
 P.O. Box 388
 Westmoreland Drive
 Youngstown, Pa. 15696-0388 U.S.A.
 Telephone: 724-537-3131 Fax: 724-537-3151
 Website: www.wmtr.com
 WMT&R is a technical leader in the material testing industry.



621-01 & 621-02

Section 1 of 2

WMT&R Report No. 5-25008
 P.O. No. P05-01764
 PQR No. 434
 Welder Jason Bever #465

April 20, 2005

CERTIFICATION

Major Tool & Machine Inc.
 1458 East 19th Street
 Indianapolis, IN 46218

Attention: Josh Mayne

Subject: All processes, performed upon the material as received, were conducted at WMT&R, Inc. in accordance with the WMT&R Quality Assurance Manual, Rev. 9, dated 4/1/2000.
 The following tests were performed on this order: IMPACT and TENSILE

TENSILE RESULTS: ASME Section IX and AWS B2.1, ASTM E21-03a

SOAK TIME: 5 Minutes

SPEED OF TESTING: 0.0050 in./in./min., 0.0500 in./min./in.

MATERIAL: Metrode ER316Mnnf

DISPOSITION: Report

Specimen ID	TestLog Number	Temp. °F/°C	UTS KSI/MPA	0.2% YS KSI/MPA	Elong %	RA %	Modulus MSI/GPA	Ult. Load LBS/NEWTONS	0.2% YLD. LBS/NEWTONS
T1	B65833	-320/-196	191.8/1320	148.7/1030	27	39	28.7/198	2630/11699	2039/9071

A/U/R: A=ACCEPTABLE, U=UNACCEPTABLE, R=REPORT

DISPOSITION: Report

Specimen ID	TestLog Number	Orig. Width (in./mm)	Final Width (in./mm)	Orig. Thick (in./mm)	Final Thick (in./mm)	Orig. Dia. (in./mm)	4D Orig GL (in./mm)	4D Final GL (in./mm)	Orig. Area (Sq. In./Sq. mm)	Failure Location/Type	Machine Number	A/U/R
T1	B65833	0.1802/4.57708	0.1437/3.650	0.0761/1.933	0.0582/1.478	0.2511/6.378	0.70/17.78	0.89/22.61	0.04183816/26.992307	WELD/DUCTILE	M9	R

A/U/R: A=ACCEPTABLE, U=UNACCEPTABLE, R=REPORT

KNOWINGLY OR WILLFULLY FALSIFYING OR CONCEALING A MATERIAL FACT ON THIS FORM OR MAKING FALSE, FICTITIOUS OR FRAUDULENT STATEMENTS OR REPRESENTATIONS HEREIN COULD CONSTITUTE A FELONY PUNISHABLE UNDER FEDERAL STATUTES. THIS CERTIFICATE OR REPORT SHALL NOT BE REPRODUCED EXCEPT IN FULL, WITHOUT THE WRITTEN APPROVAL OF WMT&R, INC.

Roy E. Starr/Matt Wojton
 _____ Technical Services Manager/ _____ Tensile Supervisor

April 20, 2005

Testing Specialists for Aerospace, Automotive, and Material Testing Fields
 Locations in Youngstown, PA U.S. 96 ~ Tel. (724) 537-3131 and
 Banbury U.K. ~ Tel. +44 (0) 1295 261211

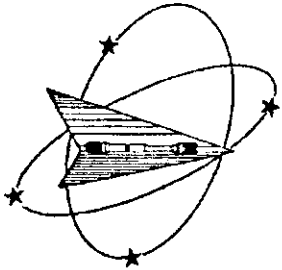

Westmoreland Mechanical Testing & Research, Inc.
 P.O. Box 388
 Westmoreland Drive
 Youngstown, Pa. 15696-0388 U.S.A.
 Telephone: 724-537-3131 Fax: 724-537-3151
 Website: www.wmtr.com
 WMT&R is a technical leader in the material testing industry.



621-01 & 621-02

Section 2 of 2

WMT&R Report No. 5-25008
 P.O. No. P05-01764

April 20, 2005

CERTIFICATION

Major Tool & Machine Inc.

TENSILE RESULTS: ASME Section IX and AWS B2.1, ASTM E21-03a

SOAK TIME: 5 Minutes

SPEED OF TESTING: 0.0050 in./in./min., 0.0500 in./min./in.

MATERIAL: Metrode ER316Mnrf

DISPOSITION: Report

Specimen ID	TestLog Number	Temp. °F/°C	UTS KSI/MPA	0.2% YS KSI/MPA	Elong %	RA %	Modulus MSI/GPA	Ult. Load LBS/NEWTONS	0.2% YLD. LBS/NEWTONS
T2	B65834	-320/-196	204.7/1410	156.5/1080	29	34	29.9/206	5095/22664	3894/17323

A/U/R: A=ACCEPTABLE, U=UNACCEPTABLE, R=REPORT

DISPOSITION: Report

Specimen ID	TestLog Number	Orig. Dia. (in./mm)	Final Dia. (in./mm)	4D Orig GL (in./mm)	4D Final GL (in./mm)	Orig. Area (Sq. In./Sq. mm)	Failure Location/Type	Machine Number	A/U/R
T2	B65834	0.1780/4.521	0.1444/3.668	0.70/17.78	0.90/22.86	0.02488456/16.054520	WELD/DUCTILE	M9	R

A/U/R: A=ACCEPTABLE, U=UNACCEPTABLE, R=REPORT

KNOWINGLY OR WILLFULLY FALSIFYING OR CONCEALING A MATERIAL FACT ON THIS FORM OR MAKING FALSE, FICTITIOUS OR FRAUDULENT STATEMENTS OR REPRESENTATIONS HEREIN COULD CONSTITUTE A FELONY PUNISHABLE UNDER FEDERAL STATUTES. THIS CERTIFICATE OR REPORT SHALL NOT BE REPRODUCED EXCEPT IN FULL, WITHOUT THE WRITTEN APPROVAL OF WMTR, INC.

 Roy E. Starr/Matt Wojton
 Technical Services Manager / Tensile Supervisor

4-20-05
 April 20, 2005

Testing Specialists for Aerospace, Automotive, and Material Testing Fields
 Locations in Youngstown, PA U.S. 97 ~ Tel. (724) 537-3131 and
 Banbury U.K. ~ Tel. +44 (0) 1295 261211

WESTMORELAND MECHANICAL TESTING & RESEARCH, Inc

Stress vs. Strain

Phone: (724)537-3131

Customer: Major Tool & Machine Inc.
WMT&R Report: 5-25008

P.O. No.: P05-01764
PQR No.: 434
Welder: Jason Bever #465

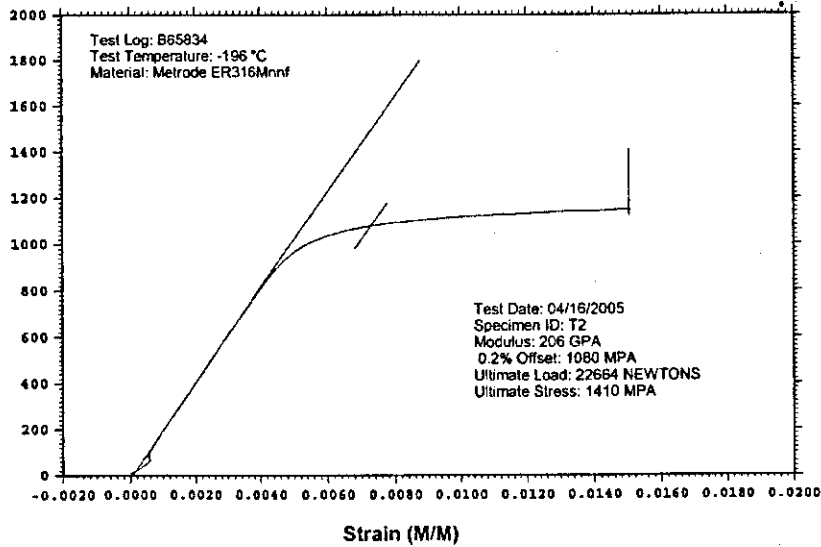
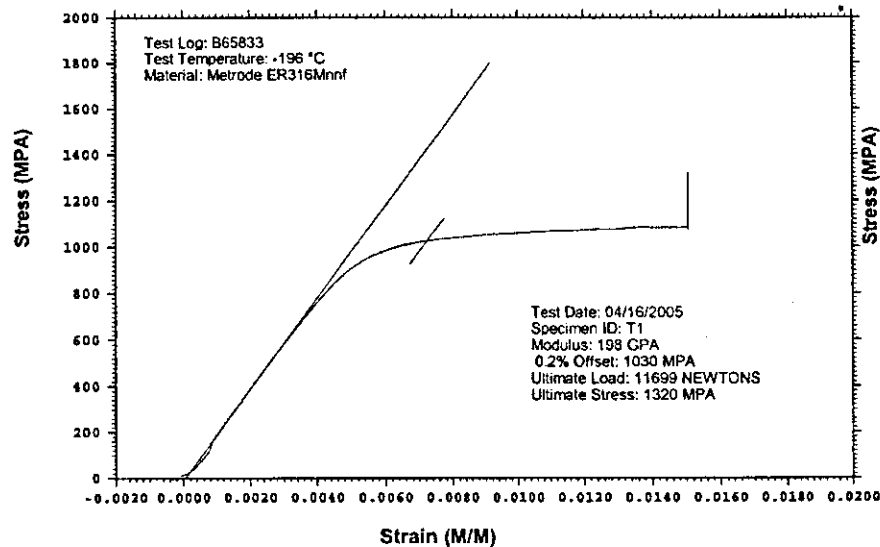
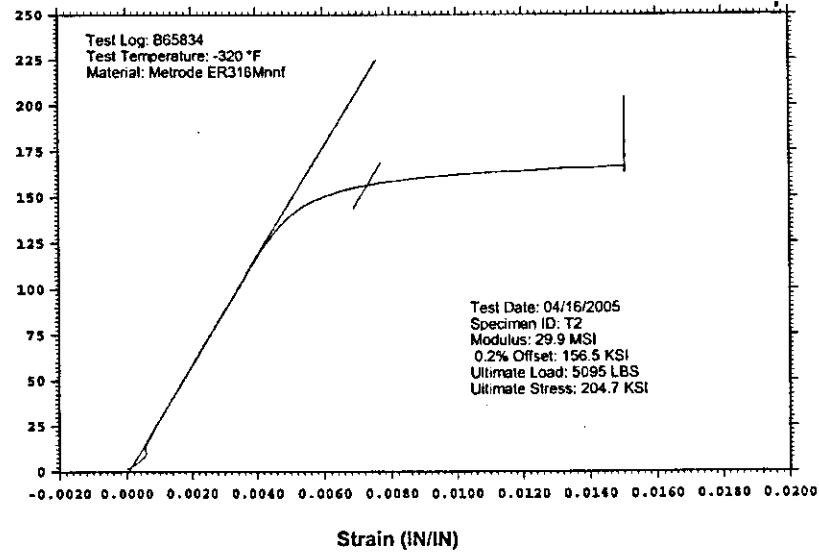
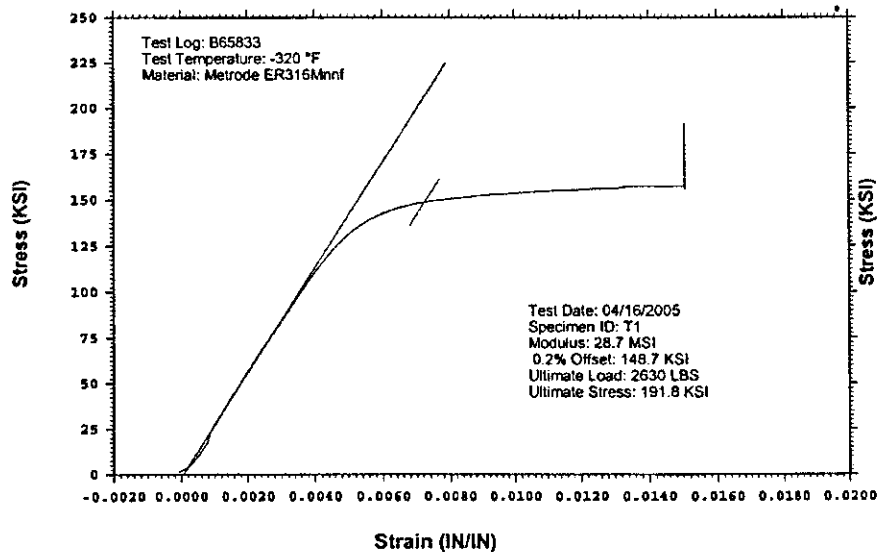



GE Advanced Materials, Polymershapes

Certificate of Conformance

Date:

Attn: Receiving Inspection
 To: Major Tool + Machine
 Address: 1458 E. 19th St.
 Indianapolis, IN 46218

Customer P.O. Number: 205-01288
 Sales Order No: 2790834

It is hereby certified that the product information provided below conforms to the corresponding information in the possession of GE Advanced Materials, Polymershapes with respect to such products. This certification and the sale of products are subject to GE Advanced Materials, Polymershapes' standard conditions of sale. This document shall not be reproduced, except in full, without prior written approval.

Quantity	Description	Lot/Specification/Standard Number
36	Glick Phenolic Sheet .062" THK X 16" X 38"	NO SPEC / N38.009023

MTM 09
 4/5/05
 APR - 5 2005
 94942
 1-18

GE Advanced Materials, Polymershapes

By: Ernest Evans
 Title: Warehouse Worker

DISCLAIMER: THE MATERIALS AND PRODUCTS OF THE BUSINESSES MAKING UP THE GE ADVANCED MATERIALS UNIT OF GENERAL ELECTRIC COMPANY, ITS SUBSIDIARIES AND AFFILIATES ("GEAM") ARE SOLD SUBJECT TO GEAM'S STANDARD CONDITIONS OF SALE, WHICH ARE INCLUDED IN THE APPLICABLE DISTRIBUTOR OR OTHER SALES AGREEMENT, PRINTED ON THE BACK OF ORDER ACKNOWLEDGMENTS AND INVOICES, AND AVAILABLE UPON REQUEST. ALTHOUGH ANY INFORMATION, RECOMMENDATIONS OR ADVICE CONTAINED HEREIN IS GIVEN IN GOOD FAITH, GEAM MAKES NO WARRANTY OR GUARANTEE, EXPRESS OR IMPLIED, (I) THAT THE RESULTS DESCRIBED HEREIN WILL BE OBTAINED UNDER END-USE CONDITIONS, OR (II) AS TO THE EFFECTIVENESS OR SAFETY OF ANY DESIGN INCORPORATING GEAM MATERIALS, PRODUCTS, RECOMMENDATIONS OR ADVICE. EXCEPT AS PROVIDED IN GEAM'S STANDARD CONDITIONS OF SALE, GEAM AND ITS REPRESENTATIVES SHALL IN NO EVENT BE RESPONSIBLE FOR ANY LOSS RESULTING FROM ANY USE OF ITS MATERIALS OR PRODUCTS DESCRIBED HEREIN. Each user bears full responsibility for making its own determination as to the suitability of GEAM's materials, products, recommendations, or advice for its own particular use. Each user must identify and perform all tests and analysis necessary to ensure that its finished parts incorporating GEAM's materials or products will be safe and suitable for use under end use conditions. Nothing in this or any other document, nor any oral recommendations or advice, shall be deemed to limit, vary, supersede, or waive any provision of GEAM's Standard Conditions of Sale or the Disclaimer, unless any such modification is specifically agreed to in a writing signed by GEAM. No statement contained herein concerning a possible or suggested use of any material, product or design is intended, or should be construed, to grant any license under any patent or other intellectual property right of General Electric Company or any of its subsidiaries or affiliates covering such use or design, or as a recommendation for the use of such material, product or design in the infringement of any patent or other intellectual property right.

Nondestructive Test Certification for Liquid Penetrant Examination

Quality Assurance Documentation for Part ID: SE141-114 - Item: 12

1458 E. 19th Street, Indianapolis, In 46218
TEL:(317)636-6433 FAX:(317)634-9420

Date of Inspection: 06/21/2006

Type of Material: CAST STAINLESS

NDT#: 17119

Stage of Inspection: <input type="checkbox"/> Incoming Inspection <input type="checkbox"/> In-Process Inspection <input type="checkbox"/> After Repair <input checked="" type="checkbox"/> Final Inspection	Manufacturing Process: <input type="checkbox"/> Weldment <input type="checkbox"/> Bar Stock <input type="checkbox"/> Forging	<input checked="" type="checkbox"/> Casting <input type="checkbox"/> Plate <input type="checkbox"/> Other	Surface Condition: <input checked="" type="checkbox"/> Machined <input type="checkbox"/> Rough <input type="checkbox"/> Other FINAL MACHINED	Test Being Run to: <input checked="" type="checkbox"/> Router Instructions <input checked="" type="checkbox"/> Drawing <input type="checkbox"/> Test Plan <input type="checkbox"/> Technique Card SEE NOTES	Heat Treated: <input type="checkbox"/> Yes <input checked="" type="checkbox"/> No
--	--	---	---	---	--

Part Information: MTM Job Number: 65709/2.0 -Sub:1 -Op:100 Resource ID: 810-LIQUID PENETRANT INSPE Part ID: SE141-114 Part Name: MODULAR COIL WINDING FOR Serial Number: Customer P.O.: S005242-F Customer Unit/Plant:	Test Results: Quantity Inspected: 1 Quantity Accepted: 0 Quantity Rejected: 1 Run Hours: 0.0	Inspection Results: Customer N/C #: <input type="checkbox"/> Accepted <input checked="" type="checkbox"/> Rejected <input type="checkbox"/> N/C-Report <input type="checkbox"/> Rework MTM N/C #: 19891
--	---	--

Customer Inspection Plan: SEE NOTES Test Step: Revision: Material Test Number:	Inspection Criteria: Customer Specification: ASTM A903/A903M MTM Spec Number: PS582 (REF NDT-WI-09) Acceptance Standard: ASTM A903 (SEE NOTES)
---	---

Inspection Materials Used: Manufacturer: SHERWIN Type of Penetrant: DP-51 Batch Number: 41-E47 Developer: D-100 Batch Number: 65-C6	Penetrant Examination Processes: Type: II (Visible) / Dwell Time: 20 Minutes Method: A (Water Wash) Method of Drying: Forced Air Fan Form: e (nonaqueous for Type II visible dye) / Dwell Time: 20 Min
--	---

Inspection Requirements:

100 % of all accessible surfaces Joint Preps Root Pass Back Gouge Cover Pass Other

Notes:
 INSPECT 100% OF SURFACES ON PRODUCTION MODULAR COIL WINDING FORM TYPE-A.
 SPECIFICATION: ASTM A903/A903M
 METHOD: ASTM E165

ACCEPTANCE CRITERIA: ASTM A903/A903M LEVEL I FOR MACHINED SURFACES INCLUDING THE ENTIRE "T" SECTION (HIGH STRESS AREAS)

PART HAS 17 REJECTABLE INDICATIONS PER CUSTOMER REQUIREMENTS ON MACHINED SURFACES. SEE NCR-20044 AND PHOTOS FOR MORE DETAILED INFO.

This is to certify that the pieces specified have been inspected in accordance with the specifications shown.

Inspector: 581-D.EDWARDS

Date: 06/21/2006

Douglas D. Edwards Level II



Quality Assurance Documentation for Part ID: SE141-114 - Item: 13

Workorder: 65709/2-0 Sub:1 Op:130





Part: SE141-114 - MODULAR COIL WINDING FORM TYPE-A - PRODUCTION MODULAR COIL WINDING FORM TYPE-A

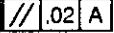

Drawing ID: SE141-101 Rev: 3			INSPECTION INSTRUCTIONS			RESULTS		INSPECTED BY			
SHEET	ZONE	CHARACTERISTIC	GAGE/EQUIP	BY	SAMPLE	SER#	DATA/REMARKS	INSP	VERFD	AUDIT	
2* (10)	D3	Ø.001 - Ø.002 CHECK CLEARANCE OF ITEM 5 TO ITEM 6.	FEELER GAGES	MFG		J-1203	ACCEPT	242-M.G 06-26-06			A
* (15)		THE GAP BETWEEN THE POLOIDAL BREAK BUSHINGS AND FLANGE SHAL BE LESS THAN .002"	FEELER GAGES	MFG		J-1203	ACCEPT	242-M.G 06-26-06			A
* (20)		ENSURE THAT THE CUMULATIVE GAP AT ANY SINGLE CROSS SECTION OF THE POLOIDAL FLANGE ELEMENTS IS LESS THAN .005".	FEELER GAGES	MFG		J-1203	NO GAP	242-M.G 06-26-06			A
* (30)		THE MAX. GAP AT THE POLOIDAL BREAK PERIMETER IS .015" AND CANNOT EXCEED 1/8" FROM THE EDGE	FEELER GAGES	MFG		J-1203	ACCEPT	242-M.G 06-26-06			A
1* (40)	F2	TORQUE ASSEMBLY TO 1500 +/- 30 FT-LBS PER DRAWING NOTE 15.	TORQUE MULTIPLI	MFG		J-1240	DONE	825-B.J 06-27-06			A

Quality Assurance Documentation for Part ID: SE141-114 - Item: 14

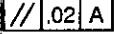
Workorder: 65709/2-0 Sub:1 Op:132

Part: SE141-114 - MODULAR COIL WINDING FORM TYPE-A - PRODUCTION MODULAR COIL WINDING FORM TYPE-A

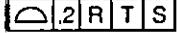
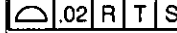
Drawing ID: SE141-114 Rev: 7			INSPECTION INSTRUCTIONS			RESULTS		INSPECTED BY		
SHEET	ZONE	CHARACTERISTIC	GAGE/EQUIP	BY	SAMPLE	SER#	DATA/REMARKS	INSP	VERFD	AUDIT
1* (10)	F3	NOTE 14 - BACK SPOTFACE ALL THRU HOLES TO MINIMUM CLEAN UP.		QA		MTMFX3564	ACCEPT	339-E.R		A
								06-27-06		
1* (20)	E8	FLANGE PROFILE +/- .25 IN THIS AREA	CMM	QA		00064	-.0027 TO -.0065	339-E.R		A
								06-27-06		
1* (30)	D8		CMM	QA		00064	.006	339-E.R		A
								06-27-06		
1* (40)	D8	54.20 ± .03	CMM	QA		00064	54.206	339-E.R		A
								06-27-06		
1* (50)	C8	54.20 ± .03	CMM	QA		00064	54.205	339-E.R		A
								06-27-06		
1* (60)	B8		CMM	QA		00064	.005	339-E.R		A
								06-27-06		
1* (70)	D5		CMM	QA		00064	.002	339-E.R		A
								06-27-06		
1* (80)	D5	48.50 ± .03	CMM	QA		00064	48.498	339-E.R		A
								06-27-06		
1* (90)	C5	48.50 ± .03	CMM	QA		00064	48.494	339-E.R		A
								06-27-06		
1* (100)	B5		CMM	QA		00064	.006	339-E.R		A
								06-27-06		
1* (110)	D4	VERIFY PART MARKING: MAJOR TOOL SE141-114 A(casting number) (weight) LBS.		QA		VISUAL	ACCEPT	339-E.R		A
								06-27-06		
1* (120)	D4	RECORD WEIGHT		QA			5180	242-M.G		A
								06-21-06		
1* (130)	D3	 OUTER AS CAST SURFACES	CMM	QA		00064	-.092 TO .553 [N/C: 20080-Doc:NC20080]	339-E.R		R
								06-27-06		
2*	F8		CALIPER	QA		P-5075	.395 TO .435 ON DAT	533-B.C		R

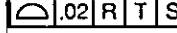
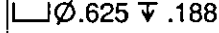
(140)		2 X .40					UM E SIDE, .355 TO .410 ON DATUM D SIDE [N/C:20080-Doc:NC20080]	06-23-06		
2*	F8		CALIPER	QA		P-5075	.035 ON DATUM E SIDE, .010 TO .035 ON DATUM D SIDE [N/C:20080-Doc:NC20080]	533-B.C		R
(150)		4 X .03 X 45						06-23-06		
2*	G6		PIN GAGE	QA		J-651-2	.187 ON DATUM E SIDE, .183 TO .192 ON DATUM D SIDE	533-B.C		A
(160)		2 X R.187 +.025 / -.005						06-23-06		
2*	G5		CMM	QA		00064	-.003 TO .081	339-E.R		A
(170)		P TO M						06-27-06		
2*	G5			QA		MTMFX-3473	REJECT - MODEL DOES NOT ALLOW FOR CLEARANCE [N/C:20080-Doc:NC20080]	339-E.R		R
(180)		DATUM D SIDE VERIFY SHELL INTERSECT CLEARANCE USING GAGE MTMFX-3473						06-27-06		
2*	F5		CMM	QA		00064	-.021 TO .012 [N/C:20080-Doc:NC20080]	339-E.R		R
(190)		M TO M1						06-27-06		
2*	E5		CMM	QA		00064	-.015 TO .017	339-E.R		A
(200)		M1 TO N1						06-27-06		
2*	G3		CMM	QA		00064	.015 TO .092	339-E.R		A
(210)		Q TO N						06-27-06		
2*	F3			QA		MTMFX-3473	ACCEPT	339-E.R		A
(220)		DATUM E SIDE VERIFY SHELL INTERSECT CLEARANCE USING GAGE MTMFX-3473						06-27-06		
2*	F3		CMM	QA		00064	-.017 TO .027 [N/C:20080-Doc:NC20080]	339-E.R		R
(230)		N TO N1						06-27-06		
2*	B4		CALIPER	QA		P-5075	.025 TO .050 [N/C:20080-Doc:NC20080]	533-B.C		R
(240)		2 X .06/.09 X 45						06-23-06		
2*	B5	Ø .375-16 UNC ▽ .750 +.1 -0.96 X	THREAD PLUG GAGE	QA	100%	A-151	ACCEPT	339-E.R		A
(250)								06-27-06		
2*	B5		PIN GAGE	QA		J-652-3	.618 TO .627 DEP TH .165 TO .193 [N/	533-B.C		R

(260)			DEPTH MICROMET		J-520	C:20080-Doc:NC20080	06-23-06		
2* (270)	B5	Φ .06 R T S	CMM	QA	00064	.005 TO .055	339-E.R		A
		.375-16 HOLES					06-27-06		
3* (280)	H3	\square .01	CMM	QA	00064	.015 [N/C:20080-Doc :NC20080]	339-E.R		R
		DATUM E FLANGE					06-27-06		
3* (285)	H4	$\sqrt{125}$	PROFILOMETER	QA	J-1109	25 TO 81	533-B.C		A
		DATUM E FLANGE					06-23-06		
3* (290)	F2	\square .01	CMM	QA	00064	.032 [N/C:20080-Doc :NC20080]	339-E.R		R
		DATUM D FLANGE					06-27-06		
3* (295)	F3	$\sqrt{125}$	PROFILOMETER	QA	J-1109	32 TO 78	533-B.C		A
		DATUM D FLANGE					06-23-06		
3* (300)	E4	\varnothing 2.50 THRU	DIAL BORE GAGE	QA	J-1401	2.495	533-B.C		A
							06-23-06		
3* (310)	F4	Φ .060 A B C	CMM	QA	00064	SEE IGES DATA	339-E.R		A
		\varnothing 2.50					06-27-06		
3* (320)	C7	8X \varnothing 1-8UNC ∇ 2	THREAD PLUG GA	QA	A-347	ACCEPT	533-B.C		A
							06-22-06		
3* (330)	C7	Φ .010 A B C	CMM	QA	00064	.016 TO .060 [N/C:2 0080-Doc:NC20080]	339-E.R		R
		8X \varnothing 1-8 UNC					06-27-06		
3* (340)	D5	8X \varnothing 1-8UNC THRU	THREAD PLUG GA	QA	A-347	ACCEPT	533-B.C		A
							06-22-06		
3* (350)	D5	\varnothing .010 A B C	CMM	QA	00064	.016 TO .066 [N/C:2 0080-Doc:NC20080]	339-E.R		R
		8X \varnothing 1-8 UNC					06-27-06		
3* (360)	D3	\varnothing 2.50 THRU	DIAL BORE GAGE	QA	J-1401	2.491	533-B.C		A
							06-23-06		
3* (370)	D3	Φ .060 A B C	CMM	QA	00064	SEE IGES DATA	339-E.R		A
		\varnothing 2.5					06-27-06		
3* (380)	D1		CMM	QA	00064	SEE IGES DATA	339-E.R		A
		40.90					06-27-06		
4* (390)	H6	\square \varnothing 2.000-2.001 ∇ 0.990-1.000	DIAL BORE GAGE	QA	J-1401	2.0005, 2.0007, 2.0 009 DEPTH .992 TO	533-B.C		A
			CALIPER		P-5075	.996	06-24-06		
4* (400)	F4	\varnothing 1.375-6UNC THRU	THREAD PLUG GA	QA	A-375	ACCEPT	533-B.C		A
							06-23-06		
4* (410)	F4	Φ \varnothing .06 M A D	CMM	QA	00064	.036	339-E.R		A
		\varnothing 1.375-6					06-27-06		

INSPECTION DATA CHECKLIST

4* (420)	D4 &	Ø1.885 ± .003 THRU	DIAL BORE GAGE	QA		J-1400	1.883 TO 1.887	533-B.C 06-23-06		A
4* (430)	D4 &	⊕ Ø.06 M A D Ø1.885	CMM	QA		00064	.012 TO .059	339-E.R 06-27-06		A
4* (440)	B6	3X Ø1.5	CALIPER	QA		J-1103	1.500 TO 1.502	533-B.C 06-23-06		A
4* (450)	B6	⊕ .06 M A D 3X Ø1.5	CMM	QA		00064	.020 TO .058	339-E.R 06-27-06		A
4* (460)	A4	6X .25-20 UNC ▽ .5 .5 X 82° CHAMFER	THREAD PLUG GA CALIPER	QA		A-715 P-5075	THE THREADS ARE A EPTABLE BUT THE CH MFER IS TOO BIG .5 00 [N/C:20080-Doc:N C20080]	533-B.C 06-24-06		R
5* (470)	D8/D6	Ø1.885 ± .003	DIAL BORE GAGE	QA		J-1400	1.8835 TO 1.884	533-B.C 06-22-06		A
5* (480)	D8/D6	⊕ Ø.06 N A E Ø1.885	CMM	QA		00064	.003 TO .074 [N/C:2 0080-Doc:NC20080]	339-E.R 06-27-06		R
5* (490)	F8	Ø1.375-6UNC THRU	THREAD PLUG GA	QA		A-375	ACCEPT	533-B.C 06-23-06		A
5* (500)	F8	⊕ Ø.06 N A E Ø1.375-6 UNC	CMM	QA		00064	.043	339-E.R 06-27-06		A
5* (510)	F6	8X 1/4 -20 UNC-2B	THREAD PLUG GA	QA		A-715	ACCEPT	533-B.C 06-23-06		A
5* (520)	D6	3X Ø1.5 ▽ 2.33	CALIPER CALIPER	QA		J-1103 P-5075	1.498 TO 1.500 DEPTH 2.330 TO 2.34 0	533-B.C 06-22-06		A
5* (530)	D6	⊕ Ø.06 N A E 3X Ø1.5	CMM	QA		00064	.024 TO .029	339-E.R 06-27-06		A
5* (540)	B3	6X .25 - 20 UNC ▽ .6 Ø.5 X 82° CHAMFER	CALIPER	QA		P-5075	.375 DIA. CHAMFER [N/C:20080-Doc:NC200 80]	533-B.C 06-23-06		R
6* (550)	H7	6.00	CMM	QA		00064	SEE IGES DATA	339-E.R 06-27-06		A
6* (560)	H7	1.00	CMM	QA		00064	SEE IGES DATA	339-E.R 06-27-06		A
6* (570)	G8	6.70	CMM	QA		00064	SEE IGES DATA	339-E.R 06-27-06		A

INSPECTION DATA CHECKLIST

6* (600)	F8	6.70	CMM	QA		00064	SEE IGES DATA	339-E.R 06-27-06		A
6* (610)	E7	5.75	CMM	QA		00064	SEE IGES DATA	339-E.R 06-27-06		A
6* (620)	E7	1.00	CMM	QA		00064	SEE IGES DATA	339-E.R 06-27-06		A
6* (630)	E6	4X Ø1.00	PIN GAGE	QA		J-921	.995	533-B.C 06-23-06		A
6* (640)	G5	2X .88 - 1.13	CALIPER	QA		P-5075	1.115 TO 1.130	533-B.C 06-23-06		A
6* (650)	F5	.06-.09 X 45° TYP	CALIPER	QA		P-5075	.065	533-B.C 06-22-06		A
7* (660)	G2	19.00	CMM	QA		00064	SEE IGES DATA	339-E.R 06-27-06		A
7* (670)	F2	2.00	CALIPER	QA		P-5075	2.00	533-B.C 06-22-06		A
7* (680)	F2	6.75	CMM	QA		00064	SEE IGES DATA	339-E.R 06-27-06		A
7* (690)	F2	3.75	CALIPER	QA		P-5075	3.745 TO 3.750	533-B.C 06-22-06		A
7* (700)	F1	4X Ø.75-10 UNC ▽ 1.50	THREAD PLUG GA	QA		A-167	ACCEPT	533-B.C 06-22-06		A
7* (710)	D1	2X 1.56 OPEN THRU	CALIPER	QA		P-5075	1.560	533-B.C 06-22-06		A
7* (720)	C1	.375-16 UNC-2B TAP ▽ .75 .03 X 45° CHAMFER 6X	THREAD PLUG GA CALIPER	QA		A-444 P-5075	ACCEPT CHAMFE R .035	533-B.C 06-22-06		A
7* (730)	C4	VERIFY THAT HOLE LOCATIONS ARE SCRIBED ON THE PART.		QA		VISUAL	ACCEPT	533-B.C 06-22-06		A
7* (740)	B3	8.50 DISTANCE BETWEEN SCRIBE MARKINGS.	CALIPER	QA		J-1389	ACCEPT	533-B.C 06-22-06		A
9* (750)	H1	2X Ø.50	PIN GAGE	QA		J-652-3	.500	533-B.C 06-23-06		A
9*	B7		PIN GAGE	QA		J-652-3	2.570 DEEP .623 D	533-B.C		A

INSPECTION DATA CHECKLIST

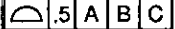
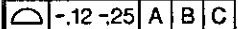
(760)		TC2 HOLE TO BE .625" IN DIAMETER APPROX 2.52" DEEP AND .25" IN DIAMETER AT LEAST 1" DEEP.	CALIPER			P-5075	IA. 1 DEEP . 252 DIA.	06-23-06			
*		TC1 LOCATION AND CONFIGURATION MODIFIED. HOLE TO HAVE .625 CLEARANCE AND AT LEAST 1" OF DEPTH AT THE .25" DI	PIN GAGE	QA		J-652-3	.623 DIA. 1.150 D EEP .252 DIA.	533-B.C		A	
(770)		CALIPER			P-5075		06-23-06				
10*	F5		CMM	QA		00064	-.034 TO -.337 / -. 341 TO .073 [N/C:20 080-Doc:NC20080]	339-E.R		R	
(780)		INNER AS CAST SURFACES					06-27-06				
10*	D5		CMM	QA		00064	-.164 TO -.197 / -. 016 TO -.206 [N/C:2 0080-Doc:NC20080]	339-E.R		R	
(790)		WING SURFACES					06-27-06				
Drawing ID: NCSX-CSPEC-141-03 Rev: 11			INSPECTION INSTRUCTIONS			RESULTS			INSPECTED BY		
SHEET	ZONE	CHARACTERISTIC	GAGE/EQUIP	BY	SAMPLE	SER#	DATA/REMARKS	INSP	VERFD	AUDIT	
4*	3.1.I.√ ¹²⁵	THE TWO "L" MACHINED SURFACES OF TEE MUST HAVE A RMS OF 125.	PROFILOMETER	QA		J-1109	15 TO 30	533-B.C		A	
(800)								06-23-06			

4959

10520 Chester Road
Woodlawn, Ohio 45215



CLIENT Major Tool & Machine		INTERPRETER/LEVEL Robert Weaver/II		RADIOGRAPHER Robert Weaver		JOB NO 13860001	P.O. NO N/A	DATE 6/26/06			
ISOTOPE-RAY IR192	DIA. X LENNY .118" x .089"	CURIES/MA 22	FOCAL SPOT SIZE .148"	SFD 17"	SOO 16.25"	TIME 4:30	FILM PROCESSING AUTO	FILM TYPE Kodak AA	FILM TECHNIQUE Double	PS SCREENS .010"	
WELD PROCESS N/A		MATERIAL SPEC 316 SST		MATERIAL DIAMETER N/A		MATERIAL THICKNESS .75"		PENETRANT ASTM IB		SHIM N/A	ACCEPTANCE STANDARD NO Defects > .080"

DESCRIPTION
65709/2.0/1/134/88
SE141-114
Page 1 of 2

REMARKS
Densitometer-12105
cal due-8-2-06
V-shrinkage-as shown on PT-NC20044 Item 4

FITTING, SEAM OR FITTING	FILM INTERVAL NUMBER	WELDER IDENTIFICATION	PENETRANT		SLAG	POROSITY	POROSITY WITH TAL	CRACK	LACK OF PEN	LACK FUSION	INTERNAL CORROSION	INTERNAL CONCAVITY	TUNGSTEN	MELT THROUGH	BURN THROUGH	CRATER PIT	CORROSION	INTERNAL UNDERCUT	EXTERNAL UNDERCUT	ALIGNED INDICATIONS	WELD CONTOUR	ING-MATCH	FILM ARTIFACT	VISUAL CONCERNS	FILM DENSITY	SEE REMARKS	ACCEPT	REJECT	
			SIZE	QUALITY LEVEL																									
T	0-1	N/A	IB	.016"	✓																								
↓	1-2	↓																											
↓	2-3	↓																											
↓	3-4	↓																											

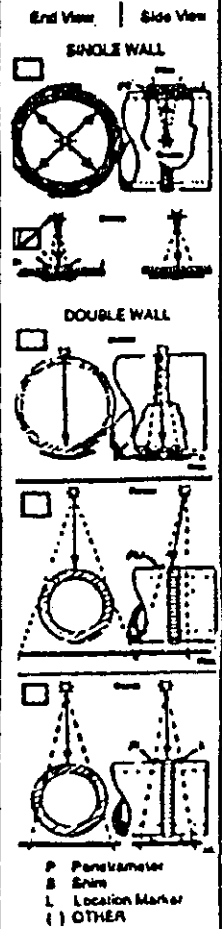

Robert Weaver 65554/TI
Cooperheat-MQS Signature

Customer Representative Signature _____ Date 6/26/06

MCWF Type A
RT Map of High Stress Region

MTM Workorder Number: _____

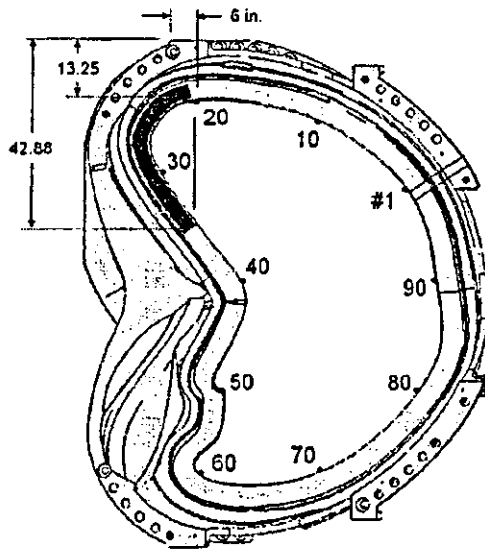
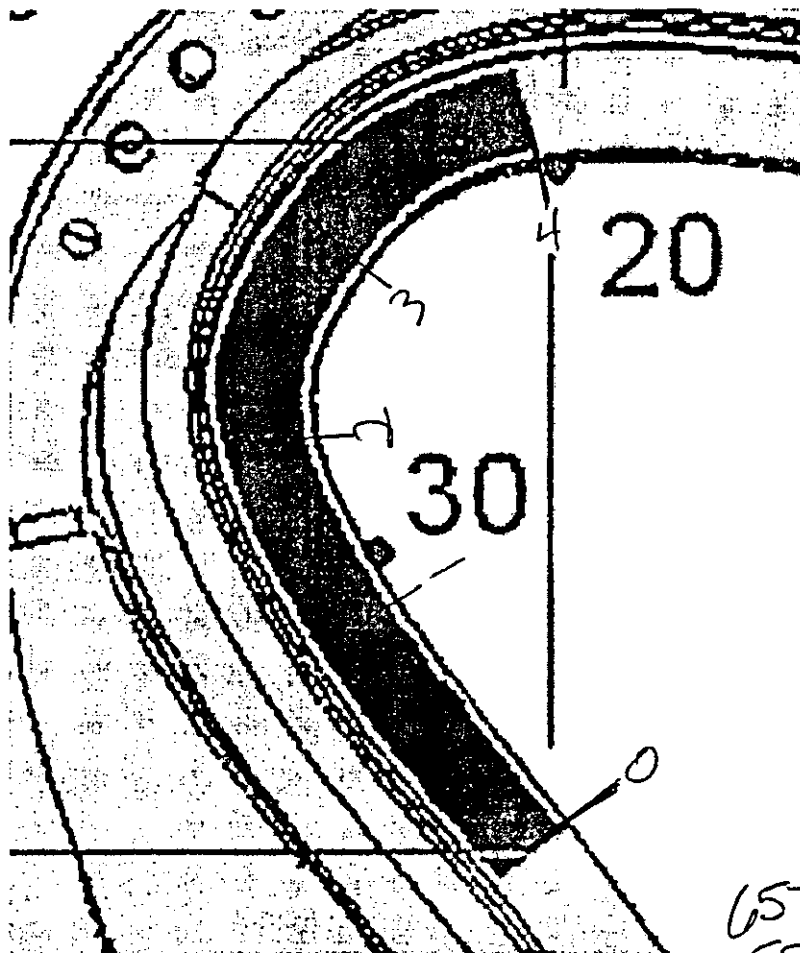

Figure 7-4- High Stress Region Identification for Type-A MCWF



65709/2.0/1/134/818
SE 141-114
6/26/06
page 2 of 2

SE141-114 TYPE A2
RT ATTACHMENT

Photo of RT film 2-3

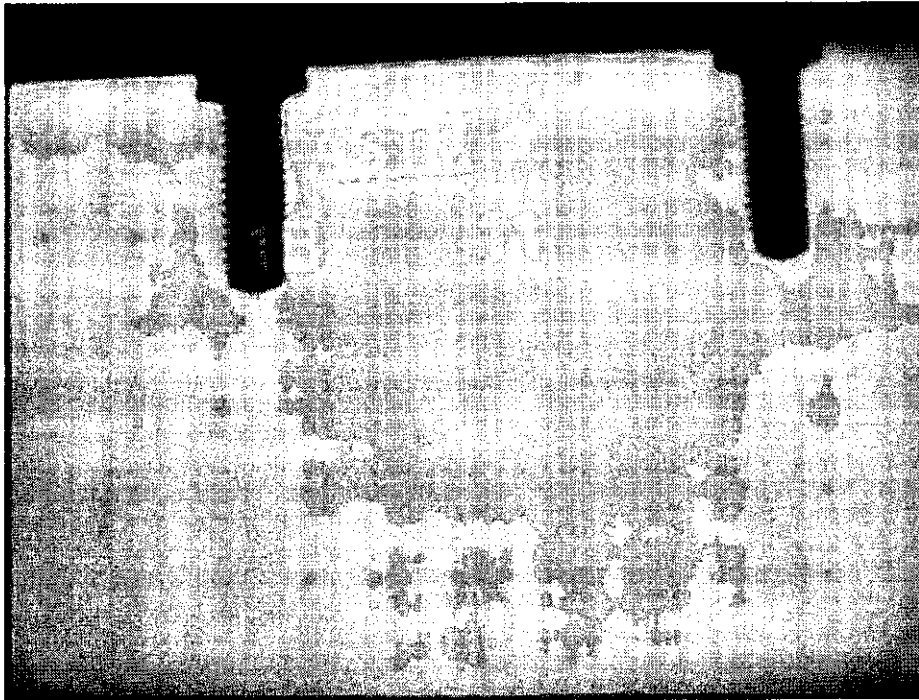
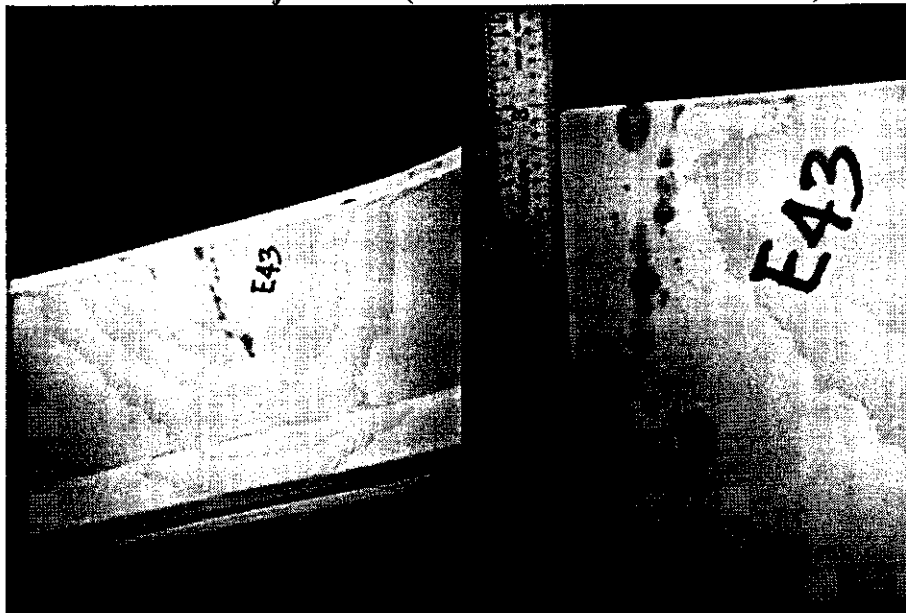

Photo of PT rejection #4 (reference NC20044 attachment)



Quality Assurance Documentation for Part ID: SE141-114 - Item: 16

Workorder: 65709/2-0 Sub:1 Op:136

Part: SE141-114 - MODULAR COIL WINDING FORM TYPE-A - PRODUCTION MODULAR COIL WINDING FORM TYPE-A

Drawing ID: SE141-114 Rev: 6			INSPECTION INSTRUCTIONS			RESULTS		INSPECTED BY			
SHEET	ZONE	CHARACTERISTIC	GAGE/EQUIP	BY	SAMPLE	SER#	DATA/REMARKS	INSP	VERFD	AUDIT	
*		D A T U M - E - S I D E MAG PERMEABILITY TO BE NO GREATER THAN 1.02μ. CHECK 3 PLACES ADJACENT TO EVERY 5TH HOLE IN T SECTION.	MASTER GAGE	QA		J-1165	LESS THAN 1.02	667-J.B			A
(10)								06-26-06			
*		D A T U M - D - S I D E MAG PERMEABILITY TO BE NO GREATER THAN 1.02μ. CHECK 3 PLACES ADJACENT TO EVERY 5TH HOLE IN T SECTION.	MASTER GAGE	QA		J-1165	LESS THAN 1.02	667-J.B			A
(20)								06-26-06			

SOUTH TEXAS BOLT & FITTING, INC
 4845 HOMESTEAD RD #500
 HOUSTON TEXAS 77028
 PH # 713 673 5376
 FAX# 713 673 5379

*** MATERIAL TEST REPORT ***
 Date 05 17 2006

SOLD TO Major Tool & Machine Inc
 1458 East 19th Street
 Indianapolis IN 46218

Customer P/O # P06 01393
STBF Order # 81140

ITEM	QTY	DESCRIPTION	LOT/HEAT				
1	50	1 3 8 6 x 9 1 2 660B Broached Tapend Stud Silver Plated per AMS 2410	XFR / E3930				
Chemical Properties							
C 046	Mn 26	P 015	S 001	Si 28	Ni 25 60	Cr 14 10	Mo 1 21
Cu 13	Co 08	V 22	Al 24	Ti 2 18	B 0054		
Mechanical Properties							
Tensile 163310	Yield 11090	Elong 23 10	RA 49 90	Hardness 290hb	Temperature 1325 f	Macro Pass	
Remarks ASTM A453 03							

Certificate of Conformance
 This is to certify that the material purchased on this order was made in accordance with and to conform to the specifications and descriptions required by the American Society for Testing Materials (ASTM) and the American Society of Mechanical Engineers (ASME)

SOUTH TEXAS BOLT & FITTING

 Lance Byrns
 Quality Coordinator

RECEIVED
 MAY 15 2006
 107579 JH
Lance 1-5

MTR
 018
 MAY 17 2006

SOUTH TEXAS BOLT & FITTING, INC. 4845 HOMESTEAD RD, #500 HOUSTON, TEXAS 77028 PH # 713-673-5376 FAX# 713-673-5379	* MATERIAL TEST REPORT * Date: 05-22-2006
--	---

SOLD TO: Major Tool & Machine, Inc. 1458 East 19th Street Indianapolis, IN 46218	Customer P/O # P06-01394 STBF Order # 81140-1A
---	---

ITEM	QTY	DESCRIPTION	LOT / HEAT
1	40	1 3/8-6 660B 12-Point Hex Nut Silver Plated Per AMS 2410	xfq / 5407813

Chemical Properties

C	Mn	P	S	Si	Ni	Cr	Mo
.034	1.50	.007	.0016	.54	25.00	14.70	1.22
Cu	Co	V	Al	Ti	B	Pb	
.06	.05	.26	.27	2.25	.0074	.0001	

Mechanical Properties

Tensile	Yield	Elong	RA	Hardness	Temperature	Macro
160000	109000	27.60	43.10	319hr	720°C	Pass

Remarks: ASTM A453

Certificate of Conformance
 This is to certify that the material purchased on this order was made in accordance with, and to conform to, the specifications and descriptions required by the American Society for Testing Materials (ASTM) and the American Society of Mechanical Engineers (ASME).

SOUTH TEXAS BOLT & FITTING

 Lance Byrns
 Quality Coordinator

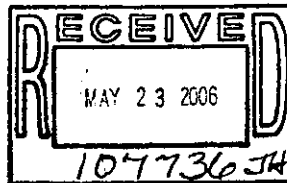

MAY 23 2006



lines 2-4

SOUTH TEXAS BOLT & FITTING, INC.
 4845 HOMESTEAD RD, #500
 HOUSTON, TEXAS 77028
 PH # 713-673-5376
 FAX# 713-673-5379

*** MATERIAL TEST REPORT ***
 Date: 05-17-2006

SOLD TO: Major Tool & Machine, Inc.
 1458 East 19th Street
 Indianapolis, IN 46218

Customer P/O # P06-01394

STBF Order # 81140-1

ITEM	QTY	DESCRIPTION	LOT / HEAT				
1	16	1 3/8"-6 660B 12 Point Hex Nut Silver Plated Per AMS 2410	XFQ / 5407813				
Chemical Properties							
C	Mn	P	S	Si	Ni	Cr	Mo
.034	1.50	.007	.0016	.54	25.00	14.70	1.22
Cu	Co	V	Al	Ti	B	Pb	
.06	.05	.26	.27	2.25	.0074	.0001	
Mechanical Properties							
Tensile	Yield	Elong	RA	Hardness	Temperature	Macro	
160000	109000	27.60	43.10	319hr	720°C	Pass	
Remarks: ASTM A453							

Certificate of Conformance

This is to certify that the material purchased on this order was made in accordance with, and to conform to, the specifications and descriptions required by the American Society for Testing Materials (ASTM) and the American Society of Mechanical Engineers (ASME).

SOUTH TEXAS BOLT & FITTING



Lance Byrns
 Quality Coordinator

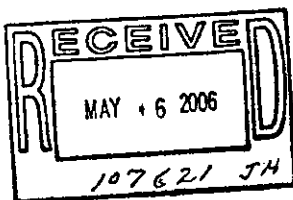

lines 1-2



MAY 17 2006

Quality Assurance Documentation for Part ID: SE141-141 - Item: 20

Workorder: 65709/2-0 Sub:14 Op:30

Part: SE141-141 - BEARING PLATE DETAIL TYPE "A" SHORT -

Drawing ID: SE141-141 Rev: 1			INSPECTION INSTRUCTIONS			RESULTS		INSPECTED BY		
SHEET	ZONE	CHARACTERISTIC	GAGE/EQUIP	BY	SAMPLE	SER#	DATA/REMARKS	INSP	VERFD	AUDIT
1*	G2	RECORD MAGNETIC PERMEABILITY. RESULTS TO BE NO GREATER THAN 1.02μ.	MASTER GAGE	QA		J-1270	LESS THAN 1.02	503-B.H		
(10)								06-20-06		

Quality Assurance Documentation for Part ID: SE141-142 - Item: 21

Workorder: 65709/2-0 Sub:15 Op:30

Part: SE141-142 - BEARING PLATE DETAIL TYPE "A" LONG -

Drawing ID: SE141-142 Rev: 1			INSPECTION INSTRUCTIONS			RESULTS		INSPECTED BY		
SHEET	ZONE	CHARACTERISTIC	GAGE/EQUIP	BY	SAMPLE	SER#	DATA/REMARKS	INSP	VERFD	AUDIT
1*	G2	RECORD MAGNETIC PERMEABILITY. RESULTS TO BE NO GREATER THAN 1.02μ.	MASTER GAGE	QA		J-1270	LESS THAN 1.02	503-B.H		
(10)								06-20-06		

Employees: 242-M.Griffith / 339-E.Root / 503-B.Houk / 533-B.Clevenger / 667-J.Bannister / 825-B.Jarrett / 840-G.Masood

PRINCETON UNIVERSITY

PLASMA PHYSIC LABORATORY -- PPPL

PRODUCT CERTIFICATION AND SHIPPING RELEASE					
PROJECT PPPL - NCSX Modular Coil Winding Form	ITEM DESCRIPTION A-1 Modular Coil Winding Form			SHIPMENT NUMBER 7	
PPPL SUBCONTRACT/ ORDER NO. S005242-F	REV. Amend #14	ITEM NO. A-2	SUPPLIER REFERENCE NO. PPPL -FP-LTS-3 with Major Tool & Machine	REV. Amend # 9	QUANTITY SHIPPED 1
SUPPLIER'S CERTIFICATION					
<p>This is to certify that the products and services identified herein have been produced under a controlled quality assurance program and are in conformance with the procurement requirements including applicable codes, standards and specifications as identified in the above-referenced documents unless noted below. Any supporting documentation will be retained in accordance with the procurement requirements.</p> <p style="text-align: center;"><i>Per agreement with PPPL, authorization to proceed with shipment is granted prior to completion of documentation package and with outstanding items as set forth below.</i></p> <p>Digitally signed by Roy Sheppard DN: CN = Roy Sheppard, C = US, O = EIO Reason: Signed for Nancy Horton per request Date: 2006.06.28 12:06:24 -04'00'</p> <p>SIGNED: <u>Roy Sheppard</u> DATE: <u>6/28/06</u></p> <p>TITLE: <u>EIO Program Manager for NCSX</u> COMPANY: <u>Energy Industries of Ohio</u></p>					
PPPL (AUTHORIZED REPRESENTATIVE) SHIPPING RELEASE					
<p>This is to certify that evidence supporting the above Supplier's Certification statement has been audited and no product/service nonconformances from procurement requirements have been found unless noted below. This product/service is hereby released for shipment.</p> <p>This section serves as the Quality Assurance release for the above described product for shipment. It does not constitute an acceptance thereof and does not relieve the Vendor, Manufacturer or Contractor of any and all responsibility or obligation imposed by the purchase contract. It does not waive any rights the Purchaser may have under the purchase contract, including the Purchaser's right to reject the above described material upon discovery of any deviations from requirements of the purchase contract, drawings and specifications.</p>					
NONCONFORMANCES FROM PROCUREMENT QUALITY REQUIREMENTS:					
<p><i>As documented on approved Metal Tek Corrective Action Reports, including CA 1308, CA1323, CA1347 plus the approved NC 20044 from Major Tool as well as the following open Nonconformance from Major Tool:</i></p> <ul style="list-style-type: none"> <i>NC 20080 for Dimensional Deviations & Visual Inspection, which is in the approval/signature process at PPPL</i> 					
REMARKS/PRODUCT SERIAL NUMBERS:					
<i>Release with open NC action as documented above.</i>					
BY PPPL QA REPRESENTATIVE (OR Designer)			Digitally signed by F. Malinowski		
F. Malinowski			DN: cn=F. Malinowski, c=US, o=PPPL, ou=QA		
			Date: 2006.06.28 12:13:00 -04'00'		