

Energy Industries of Ohio

Contract # S005242-F

Modular Coil Winding Form

C-4 Documentation Package

7/14/06

This C-4 Documentation consists of:

Part 1

Final documentation package Metal Tek International – Pages 3

–

Latest revision 7/14/2006

Foundry documentation

Part 2

Final documentation package Major Tool & Machine Pages

Latest revision

Machine shop documentation

Part 3

Metal Tek radiographic films from part 1 (shipped to PPPL)

Major Tool radiographic films from part 2 (shipped to PPPL)

Energy Industries of Ohio

Contract # S005242-F

Modular Coil Winding Forms

C-4 Documentation Package

**Part 1 – Metal Tek International
Casting Data Package**

Revised 7/14/2006

****Note – Document #'s listed in the TOC (page 4) are not necessarily the same as the number hand written on the top of the document. Please use page # to find relevant document.**

C-4 Documentation Package

List of Documents 7-14-06

Doc #	Description	Pages
1	MTR for weighted average of chemistry – 3 ladles replaced by product analysis	5
2	MTR from Wisconsin Centrifugal	6
3	MTR for C-4 Shim dated 9/24/05	7
5	Lincoln weld metal product conformance spec Lot 3018926/78309	8
6	Lincoln weld metal product conformance spec Lot 3018513/78308	9
7	Metrode weld metal product conformance spec Lot WO19711	10
8	St Louis Test Lab dated 8/9/05 mech test results at RT & Charpy V notch @ 293°k for Lincoln lot 3018926/78308	11
9	Westmoreland mech test @ -320°F dated 4/28/05 - Metrode lot WO19711	13
10	St Louis Test Lab - 4/22/05 - RT mech test results Metrode WO19711 (revised 6/15/05)	14
11	St Louis Test Lab dated 8/16/05 mech test results at RT & Charpy V notch @ 293°k for Lincoln lot 3018513/78308	15
12	Westmoreland mech test @ -320°F dated 10/18/05 Lot 3018513/78308	17
13	St Louis Test Lab -10/5/05 CVN @ -320°F Lincoln Lot # 3018513/78308	18
14	Westmoreland mech test & CVN @ -320°F dated 9/13/05 Lot 3018926/78309	19
15	St Louis Test Lab dated 10/5/05 CVN @ -320°F Metrode WO19711	21
16	Westmoreland Tensile test report @ -320°F dated 9-9-05	22
17	St Louis Test Lab dated 10-10-05 – incl. tensile test results @ room temp & Charpy V Notch (CVN) at 77°K & 293°K	23
18	Weld map	26
19	Radiographic Standard Shooting Sketch	35
20	MQS Radiographic Inspection Report dated 8/13/05	36
21	MQS Radiographic Inspection Report dated 10/09/05	42
22	MTK Radiographic Interpretation Report dated 10/24	44
23	MTK Radiographic Interpretation Report dated 10/26	45
24	MTK Radiographic Interpretation Report C-4 shim dated 10/26	46
25	C-4 Coil heat treat chart dated 7/26/05	48
26	C-4 Coil stress relief dated 10/29/05	49
27	C-4 Shim heat treat chart dated 06/02/05	50
28	MTK signed MTS C-4 Coil	51
29	MTK signed MTS C-4 Coil shim	63
30	CA 1308 – shim chemistry out of spec - NOTE signature stripped by Adobe	69
31	CA 1323 – revised & inserted 3/16/06	71
32	CA 1379 Failed weld test on Lincoln weld metal # 3018926/78309	76
33	CA 1423 Weld material out of spec – NOTE signature stripped by Adobe	78
34	CA 1433 – on R-2 weld repairs of C-4 dated 10/27/05	80
35	Final inspection report C-4 Coil dated 10/26/05	81
36	C of C for C-4 Coil dated 10/26/05	82
37	Final Inspection report C-4 shim dated 10/28/05	83
38	C of C for C-4 shim dated 10/28/05	84
39	EIO shipping release for C-4 dated 10/31/05	85



4

Carondelet Division

8600 Commercial Blvd. - Pevely, MO 63070 USA
Phone: 636-479-4499 - Fax: 636-479-3399

Material Test Report

ENERGY INDUSTRIES OF OHIO

Purchase Order Number PPPL-FP-LTS-2

Cert Number S75920-3

Pattern Number MCWF-C4

Pour Date 7/12/2005

CAF Metal Designation CF8MNMnMod

Material Spec CF8MNMnMOD

Weighted average of 3 heats - 30108(38%),30109(23%),30112(39%) Total Weight 32028 lbs.

Revised 10/26/05

Element	Min	Actual	Max
C	0.04	0.04	0.07
MN	2.3	2.5	2.8
SI	0.0	0.4	0.7
CR	18.0	18.2	18.5
NI	13.0	13.2	13.5
MO	2.1	2.2	2.5
P*	0.0	0.030	0.035
S*	0.0	0.013	0.025
N	0.24	0.26	0.28

*P & S taken from ladle sample button and analyzed by wet chemistry, ASTM E1019-03 for sulfur and Colormetric for phosphorous.

PRODUCT ANALYSIS

Results of spectrometer analysis of cast on test bar after spectrometer preventive maintenance performed and at Wisconsin Centrifugal.

***Not analyzed on spectrograph.

Element	CAF after PM	WC Analysis
C	***	0.04
MN	1.4	1.5
SI	0.6	0.6
CR	18.2	17.8
NI	13.6	13.6
MO	2.4	2.4
P	0.031	0.030
S	0.009	0.012
N	***	0.25

Charles A. Ruud
Quality Assurance Manager

Superior Quality Engineered Metal Products

www.MetalTekInt.Com



Carondelet Division

8600 Commercial Blvd. - Pevely, MO 63070 USA
Phone: 636-479-4499 - Fax: 636-479-3399

Material Test Report

ENERGY INDUSTRIES OF OHIO

Purchase Order Number PPPL-FP-LTS-2

Pattern Number MCWF-C4

CAF Metal Designation CF8MNMnMod

Material Spec CF8MNMnMOD

Analysis performed by Wisconsin Centrifugal

Revised 11/3/05

Cert Number S75920-3

Pour Date 7/12/2005

Element	Min	Actual	Max
C	0.04	0.04	0.07
MN*	2.3	1.5	2.8
SI	0.0	0.6	0.7
CR*	18.0	17.8	18.5
NI*	13.0	13.6	13.5
MO	2.1	2.4	2.5
P	0.0	0.030	0.035
S	0.0	0.012	0.025
N	0.24	0.25	0.28

* See Corrective Action Number 1323.

Respectfully Submitted,
Charles A. Ruud
Quality Assurance Manager

Superior Quality Engineered Metal Products

www.MetalTekInt.Com

Carondelet Division

8600 Commercial Blvd. - Pevely, MO 63070 USA
Phone: 636-479-4499 - Fax: 636-479-3399

Material Test Report

ENERGY INDUSTRIES OF OHIO

Purchase Order Number PPPL-FP-LTS-2 Heat Number 29198 Pour Date 4/28/2005
Pattern Number SE-141-073 COIL C SHIM (-3 thru -6 Parts) Cert Number S73220-2 and
SE-141-033 COIL A SHIM (-1 thru -6 Parts) Cert Number S76220-1
CAF Metal Designation CF8MNMnMod
Material Spec CF8MNMN MOD

Revised 9/24/05

Element	Min	Actual	Max
C	0.040	0.070	0.070
CR	18.000	18.100	18.500
MN	2.300	2.970	2.800
MO	2.100	2.450	2.500
N	0.240	0.255	0.280
NI	13.000	13.120	13.500
P*	0.000	0.013	0.035
S*	0.000	0.010	0.025
SI	0.000	0.700	0.700

MN & SI previously reported on CA 1308 and were accepted.

*P & S taken from test from heat parts were poured from and analyzed by wet chemistry, ASTM E1019-03 for sulfur and Gravimetric for phosphorous.

This report covers the eleven castings poured from heat 29198. Only parts listed above however will be shipped for this order. Each casting has a unique number stamped in the part adjacent to the pattern number to differentiate the part and subsequent reporting that will be traced to the casting.

Specification limits have been updated to latest specification.

Respectfully Submitted,
Charles A. Ruud
Quality Assurance Manager

Superior Quality Engineered Metal Products
www.MetalTekInt.Com

045

ER316 MNH F 9



PRODUCT CONFORMANCE REPORT

Product	LNM 4455	Size(s) mm	1,2
Class.	EN 12072-99: G 20 16.3 Mn L	Lot/Batch	3018926/78309
		Item No.	692129
Customer	CK SUPPLY Contact Ernie Simpson Eureka (MISSOURI) 63025 UNITED STATES	Quantity	450,0 KG
		Customer ref.	P.O. SL 057549
		LSW Order No.	SD424496

Chemical analysis (%)										EN10204 3.1B
C	Si	Mn	P	S	Cr	Ni	Mo	Cu	N	
0,02	0,4	7,3	0,019	0,001	20,1	16,3	2,9	0,1	0,200	

Mechanical tests, all weld metal EN10204

Additional information EN10204
Other tests

Remarks

The product identified above has been manufactured, tested and supplied in compliance with a Quality Assurance Programme that fulfils the requirements of EN 29000/ ISO 9000/BS 5750 or similar standard.
We herewith certify that the product complies with the above-mentioned standards.
Certified ISO 9001:2000.

Company	Lincoln Smitweld B.V.	Issued by	P. van Etteger	Function	QS Manager	Date	10/02/2005	Cert.No.	3018926/7830
Registered Office	Nieuwe Dukenburgseweg 20 6534 AD NIJMEGEN	Telephone:	31 24 3522911	Fax:	31 24 3522200				
									8



PRODUCT CONFORMANCE REPORT



Product	LNM 4455	Size(s) mm	1,2
Class.	EN 12072-99: G 20 16 3 Mn L	Lot/Batch	3018513/78308
		Item No.	692129
Customer	EUROWELD MOORESVILLE N.C. 28117 UNITED STATES	Quantity	105,0 KG
		Customer ref.	P.O.: 05 - 46
		LSW Order No.	SD427896

Chemical analysis (%)										EN10204 2.2
C	Si	Mn	P	S	Cr	Ni	Mo	Cu	N	
0,01	0,5	7,3	0,015	0,001	20,3	15,4	2,9	0,1	0,19	

Mechanical tests, all weld metal										EN10204 2.2
Tensile testing					Impact testing					
Cond.	Temp.	Rp0.2	Rm	A5	Cond.	Temp.1	Av1			
	°C	N/mm2	N/mm2	%		°C	J			
AW	RT	407	623	41	AW	-196	67			

Additional information										EN10204 2.2
Other tests										

Remarks

Impact testing (individual values): 70J - 65J - 67J.

The product identified above has been manufactured, tested and supplied in compliance with a Quality Assurance Programme that fulfils the requirements of EN 29000/ISO 9000/BS 5750 or similar standard.

We herewith certify that the product complies with the above-mentioned standards. Certified ISO 9001:2000.

Company	Lincoln Smitweld B.V.	Registered Office	Nieuwe Dukenburgseweg 20 6534 AD NIJMEGEN	Post address	P.O. Box 253 6500 AG Nijmegen	Issued by	P. Nagels	Telephone	31 24 3522911	Function	QA Administrator	Date	22/03/2005	Cert.No.	3018513/7830
										Fax:	31 24 3522200				

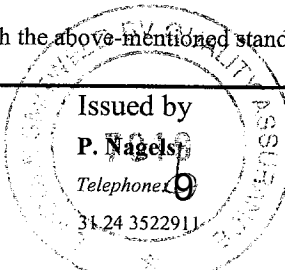

METRODE PRODUCTS LIMITED
HANWORTH LANE, CHERTSEY

CERTIFIED MATERIAL TEST REPORT



SURREY, UK, KT16 9LL

Tel: +44 (0) 1932 566721

Fax: +44 (0) 1932 565168

Email: info@metrode.com

Website: www.metrode.com

THIS PRODUCT HAS BEEN MANUFACTURED
AND SUPPLIED THROUGH A SYSTEM
APPROVED TO ISO 9001 & 2 OR EQUIVALENT



TEST CERTIFICATE NUMBER

175185

INVOICE TO
Euroweld Ltd
255 Rolling Hills Road
Mooresville
NC 28117
USA

DESPATCHED TO
Euroweld Ltd
255 Rolling Hills Road
Mooresville
NC 28117
USA

CUSTOMER ORDER NUMBER	N 03-134
DELIVERY NOTE DOCUMENT NUMBER	DN0096436
QUANTITY (KG)	40.5000
OUR ORDER REFERENCE	SO1777956 / 1
DATE	07/01/04

METRODE WELDING CONSUMABLE	ULTRAMET B316NF 4.0MM
FORM	MMA ELECTRODE
BATCH NUMBER	WO19711
SPECIFICATION	BS EN 1600:1997 E 18 15 3 L B 4 2

Chemical Analysis (Weight %)										Type: BS EN 10204: 3.1.B / ASME SFA-5.01: Sch. H			
C	Mn	Si	S	P	Cr	Ni	Mo	Cu	N				
0.02	3.28	0.24	0.009	0.023	18.0	15.4	2.80	0.07	0.11				

--	--	--	--	--	--	--	--	--	--	--	--	--	--

Mechanical Tests						Type: BS EN 10204: 2.2		
Tensile Tests						Impact Energies		
Condition	Test Temperature	Rp0.2% (MPa)	Rm (MPa)	A4 (%)	Z (%)	Temperature (°C)	Impact Energy (J)	Lateral Expansion (mm)
AS-WELDED	ROOM	>420	>600	38	54	-196	>40	

Metrode Products Limited certifies that the above material conforms to the indicated specifications

This document is produced electronically and is valid without signature.

IMPORTANT: Any liability arising from either reliance on this certificate, or use of our products, is strictly limited and governed by our conditions of business

Barrie Kyle - Q.A. Manager

ASME SFA-5.01: Lot classification: C4

Notes:
% Ni includes incidental Co unless otherwise specified
% Nb (Cb) includes incidental Ta unless otherwise specified
Ferrite is given as FN (Ferrite number) and measured on all-weld pad using instrument calibrated against NBS-related secondary standards (See AWS A4 2-97) unless otherwise specified



10

2810 Clark Avenue • St. Louis, MO 63103-2574 • (314) 531-8080 • FAX (314) 531-8085
 Chemical, Metallurgical, Mechanical, Nondestructive, Environmental Testing, Analyses and Field Service.

METALTEK INTERNATIONAL
 8600 Commercial Blvd.
 Pevely, MO 63070

August 8, 2005
 Lab No. 05P-2334
 P.O. No. 21324
 Page 1 of 3

Attention: **CHUCK RUUD**

REPORT OF MECHANICAL TESTS

- SAMPLE ID:**
- 1) STOCK# LNM 4455, LINCOLN LOT 3018926/78309
 - 2) STOCK# LNM 4455, LINCOLN LOT 3017006/72262
 - 3) STOCK# LNM 4455, LINCOLN LOT 3012668/82743
 - 4) STOCK# B316NF METRODE, W021735

Sample ID	Original Area Sq. Inches	Reduced Area Sq. Inches	Reduction in Area %	Modules of Elasticity	Yield Strength PSI	Tensile Strength PSI	Elongation (2.0" Gage Length)	
							in.	%
1	0.1385	0.0897	54.3	24.5 Msi	56900	93900	0.84	42.0
2	0.1886	0.0935	50.4	24.9 Msi	54900	92100	0.85	42.5
3	0.1909	0.0951	50.2	22.6 Msi	57400	93700	0.83	41.5
4	0.1901	0.0962	49.4	23.0 Msi	54800	88200	0.75	37.5

Round, reduced section all weld tensiles

Yield taken at .2% offset

Tested in accordance with ASTM A 370-03a

Identification of tested specimens provided by the client.

KS/tlv

[Signature]
 Karl Schmitz, Director
 Materials Testing



Certificate No. 0397-01
 Certificate No. 0397-02

AN OFFICIAL COPY OF TEST REPORT WILL BE PROVIDED BY THIS LABORATORY ON REQUEST.
 NOT OFFICIAL WITHOUT THE RAISED SEAL OF ST. LOUIS TESTING LABORATORIES, INC.
 SEE REVERSE FOR CONDITIONS.

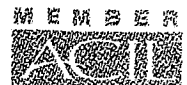



2810 Clark Avenue • St. Louis, MO 63103-2574 • (314) 531-8080 • FAX (314) 531-8085
 Chemical, Metallurgical, Mechanical, Nondestructive, Environmental Testing, Analyses and Field Service.

METALTEK INTERNATIONAL
 8600 Commercial Blvd.
 Pevely, MO 63070

August 8, 2005
 Lab No. 05P-2334
 P.O. No. 21324
 Page 2 of 3

Attention: Chuck Ruud

REPORT OF CHARPY IMPACT TEST

MATERIAL (SAMPLE ID): STOCK# LNM 4455, LINCOLN LOT 3018926/78309
 STOCK# LNM 4455, LINCOLN LOT 3017006/72262

- SPECIFICATION:** ASTM A 370-03a
SPECIMEN TYPE: "A" Vee Notch
SPECIMEN SIZE: 10 mm x 10 mm (All Weld)
TEMPERATURE OF TEST: 293°K
REQUIREMENTS:

ALL WELD	FOOT LBS.	LATERAL EXPANSION	% SHEAR
78309-7	97	0.074	50
78309-8	96	0.076	50
78309-9	108	0.075	50
Average	100	0.075	50
ALL WELD	FOOT LBS.	LATERAL EXPANSION	% SHEAR
72262-7	126	0.098	50
72262-8	102	0.080	50
72262-9	123	0.087	50
Average	117	0.088	50

Identification of tested specimen provided by client.

[Signature]
 Karl Schmitz, Director
 Materials Testing

KS/tlv



Certificate No. 0397-01
 Certificate No. 0397-02

AN OFFICIAL COPY OF TEST REPORT WILL BE PROVIDED BY THIS LABORATORY ON REQUEST.
 NOT OFFICIAL WITHOUT THE RAISED SEAL OF ST. LOUIS TESTING LABORATORIES, INC.
 SEE REVERSE FOR CONDITIONS.



11 B

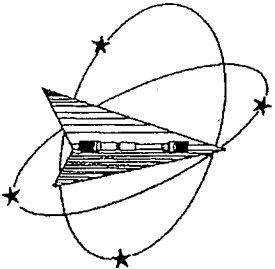

Westmoreland Mechanical Testing & Research, Inc.
 P.O. Box 388
 Westmoreland Drive
 Youngstown, Pa. 15696-0388 U.S.A.
 Telephone: 724-537-3131 Fax: 724-537-3151
 Website: *www.wmtr.com*
 WMT&R is a technical leader in the material testing industry.



621-01 & 621-02

April 28, 2005

CERTIFICATION

Section 1 of 1

MetalTek International
 The Carondelet Division
 8600 Commercial Blvd.
 I-55 Industrial Park
 Pevely, MO 63070-1528

WMT&R Report No. 5-26097
 P.O. No. 19386R9
 WMT&R Quote No. QN250563
 Req. No. 4315

Attention: Rick Suria

Subject: All processes, performed upon the material as received, were conducted at WMT&R, Inc. in accordance with the WMT&R Quality Assurance Manual, Rev. 9, dated 4/1/2000.
 The following tests were performed on this order: TENSILE

TENSILE RESULTS: ASTM E21-03a

Requirements: UTS ksi (Min 95\Max ---) 0.2% YS ksi (Min 72\Max ---) 4D Elong. % (Min 32\Max ---) Modulus Msi (Min 21\Max ---)

SOAK TIME: 5 Minutes

SPEED OF TESTING: 0.0050 in./in./min., 0.0500 In./min.in.

MATERIAL: 316 S/S

DISPOSITION: Acceptable

Sample	TestLog Number	Temp. °F	UTS ksi	0.2% YS ksi	Elong %	RA %	Modulus Msi	Ult. Load lbf	0.2% YLD. lbf	Orig. Dia. (in.)	Final Dia. (in.)	4D Orig GL (in.)	4D Final GL (in.)	Orig. Area (sq. in.)	Machine Number	AIUR
Bar#1 (Lot#3012668/82743)	B75123	-320	187.7	126.3	33	22	27.1	37740	25394	0.5060	0.4471	2.00	2.65	0.20109020	M9	A
Bar#2 (Batch#W019711)	B75124	-320	166.9	109.5	34	27	26.4	33500	21990	0.5056	0.4315	2.00	2.67	0.20077240	M9	A

AIUR: A=ACCEPTABLE, U=UNACCEPTABLE, R=REPORT

OK Check

Matthew Watson
 Roy E. Starr / Matt Wolton
 Technical Services Manager / Tensile Supervisor
 4-28-05
 April 28, 2005

KNOWINGLY OR WILLFULLY FALSIFYING OR CONCEALING A MATERIAL FACT ON THIS FORM OR MAKING FALSE, FICTITIOUS OR FRAUDULENT STATEMENTS OR REPRESENTATIONS HEREIN COULD CONSTITUTE A FELONY PUNISHABLE UNDER FEDERAL STATUTES. THIS CERTIFICATE OR REPORT SHALL NOT BE REPRODUCED EXCEPT IN FULL, WITHOUT THE WRITTEN APPROVAL OF WMT&R, INC.

Testing Specialists for Aerospace, Automotive, and Material Testing Fields
 Locations in Youngstown, PA U.S.A. Tel. (724) 537-3131 and
 Banbury U.K. ~ Tel. +44 (0) 1295 261211

10 B



2810 Clark Avenue • St. Louis, MO 63103-2574 • (314) 531-8080 • FAX (314) 531-8085

METALTEK INTERNATIONAL
8600 Commercial Blvd.
Pevely, MO 63070

April 22, 2005
Lab No. 05P-1170
P.O. No. 12516
Page 1 of 1
(revised 6/15/05)

Attention: **Chuck Ruud**

REPORT OF MECHANICAL TESTS

SAMPLE ID: 1 Ea., Sample Bar #1, Lot 3012668/82743
1 Ea., Sample Bar #2, Batch # WO19711

Sample ID	Original Area Sq. Inches	Reduced Area Sq. Inches	Reduction In Area %	Yield Strength PSI	Tensile Strength PSI	Elongation (2.0" Gage Length)		Elastic Modulus
						in.	%	
#1	.1901	.0855	55.0	56,500	85,000	0.80	55.0	25.5 MSI
#2	.1917	.0881	54.0	63,900	98,100	0.88	54.0	23.1 MSI

Round, reduced section all weld room temperature tensiles

Yield taken at .2% offset

Tested in accordance with ASTM A 370

Identification of tested specimens provided by the client

KS/tw

Karl Schmitz
Karl Schmitz, Director
Materials Testing



Certificate No. 0397-01
Certificate No. 0397-02

AN OFFICIAL COPY OF TEST REPORT WILL BE PROVIDED BY THIS LABORATORY ON REQUEST. DO NOT REPRODUCE.
NOT OFFICIAL WITHOUT THE RAISED SEAL OF ST. LOUIS TESTING LABORATORIES, INC.
SEE REVERSE FOR CONDITIONS.



2810 Clark Avenue • St. Louis, MO 63103-2574 • (314) 531-8080 • FAX (314) 531-8085
 Chemical, Metallurgical, Mechanical, Nondestructive, Environmental Testing, Analyses and Field Service.

METALTEK INTERNATIONAL
 8600 Commercial Blvd.
 Pevely, MO 63070

August 16, 2005
 Lab No. 05P-2532
 P.O. No. 21324
 Page 1 of 2

Attention: Chuck Ruud

REPORT OF CHARPY IMPACT TEST

MATERIAL (SAMPLE ID): LNM 4455, LINCOLN LOT 3018513/78308
SPECIFICATION: ASTM A 370-03a
SPECIMEN TYPE: "A" Vee Notch
SPECIMEN SIZE: 10 mm x 10 mm
TEMPERATURE OF TEST: 293°K

BASE METAL	FOOT LBS.	LATERAL EXPANSION	% SHEAR
LNM4455-7	104	0.085	100
LNM4455-8	106	0.093	100
LNM4455-9	99	0.084	100
Average	103	0.087	100

Identification of tested specimen provided by client.

KS/tlv

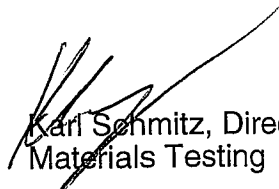
 Karl Schmitz, Director
 Materials Testing



Certificate No. 0397-01
 Certificate No. 0397-02

AN OFFICIAL COPY OF TEST REPORT WILL BE PROVIDED BY THIS LABORATORY ON REQUEST.
 NOT OFFICIAL WITHOUT THE RAISED SEAL OF ST. LOUIS TESTING LABORATORIES, INC.
 SEE REVERSE FOR CONDITIONS.



10A



2810 Clark Avenue • St. Louis, MO 63103-2574 • (314) 531-8080 • FAX (314) 531-8085
 Chemical, Metallurgical, Mechanical, Nondestructive, Environmental Testing, Analyses and Field Service.

METALTEK INTERNATIONAL
 8600 Commercial Blvd.
 Pevely, MO 63070

August 16, 2005
 Lab No. 05P-2532
 P.O. No. 21324
 Page 2 of 2

Attention: **CHUCK RUUD**

REPORT OF MECHANICAL TESTS

SAMPLE ID: LNM 4455, LINCOLN LOT 3018513/78308

Sample ID	Original Area	Reduced Area	Reduction in Area %	Yield Strength PSI	Tensile Strength PSI	Elongation (2.0" Gage Length)		Modules of Elasticity
	Sq. Inches	Sq. Inches				in.	%	
LNM4455	0.1932	0.0866	55.2	65200	95200	0.76	38.0	23.4

Round, reduced section tensiles

Yield taken at .2% offset

Tested in accordance with ASTM A 370-03a

Identification of tested specimens provided by the client.

[Signature]
 Karl Schmitz, Director
 Materials Testing

KS/tlv



Certificate No. 0397-01
 Certificate No. 0397-02

AN OFFICIAL COPY OF TEST REPORT WILL BE PROVIDED BY THIS LABORATORY ON REQUEST.
 NOT OFFICIAL WITHOUT THE RAISED SEAL OF ST. LOUIS TESTING LABORATORIES, INC.
 SEE REVERSE FOR CONDITIONS.



117

..#30282 PAGE: 2/2

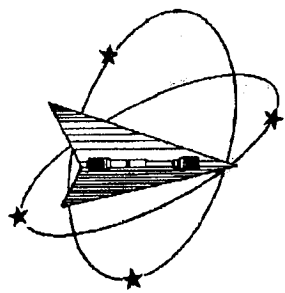

Westmoreland Mechanical Testing & Research, Inc.
 P.O. Box 388
 Westmoreland Drive
 Youngstown, Pa. 15696-0388 U.S.A.
 Telephone: 724-537-3131 Fax: 724-537-3151
 Website: www.wmtr.com
WMT&R is a technical leader in the material testing industry.



October 18, 2005

CERTIFICATION

MetalTek International
 The Carondelet Division
 8600 Commercial Blvd.
 I-55 Industrial Park
 Pevely, MO 63070-1528

Attention: Jim Galaske

Subject: All processes, performed upon the material as received, were conducted at WMT&R, Inc. in accordance with the WMT&R Quality Assurance Manual, Rev. 9, dated 4/1/2000.
 The following tests were performed on this order: TENSILE

Section 1 of 1

WMT&R Report No. 5-35979
 Requisition No. 4972

TENSILE RESULTS: ASTM E21-03a

SOAK TIME: 5 Minutes

SPEED OF TESTING: 0.0030 in./in./min., 0.0500 in./min./in.

MATERIAL: METALTEK CF8MNMNMOD

DISPOSITION: Report

Specimen ID	TestLog Number	Temp. °F	UTS ksi	0.2% YS ksi	Elong %	RA %	Modulus Msi	Ult. Load lbf	0.2% YLD. lbf	Orig. Dia. (in.)	Final Dia. (in.)	4D Orig GL (in.)	4D Final GL (in.)	Orig. Area (sq. in.)	Machine Number	AIUR
3018513/78308	C54936	-320	184.9	123.7	33	33	32.8	18470	12350	0.3566	0.2926	1.40	1.86	0.09987403	M9	R

AIUR: A=ACCEPTABLE, U=UNACCEPTABLE, R=REPORT

FAX_NO: 5377087

14:29 OCT 18, 2005

KNOWINGLY OR WILLFULLY FALSIFYING OR CONCEALING A MATERIAL FACT ON THIS FORM OR MAKING FALSE, FICTITIOUS OR FRAUDULENT STATEMENTS OR REPRESENTATIONS HEREIN COULD CONSTITUTE A FELONY PUNISHABLE UNDER FEDERAL STATUTES. THIS CERTIFICATE OR REPORT SHALL NOT BE REPRODUCED EXCEPT IN FULL, WITHOUT THE WRITTEN APPROVAL OF WMT&R, INC.

 Roy E. Starni
 Technical Services Manager / Tensile Supervisor

10-18-05

October 18, 2005

Testing Specialists for Aerospace, Automotive, and Material Testing Fields
 Locations in Youngstown, PA U.S.A. ~ Tel. (724) 537-3131 and
 Banbury U.K. ~ Tel. +44 (0) 1295 261211

2810 Clark Avenue • St. Louis, MO 63103-2574 • (314) 531-8080 • FAX (314) 531-8085
 Chemical, Metallurgical, Mechanical, Nondestructive, Environmental Testing, Analyses and Field Service.

METALTEK INTERNATIONAL
 8600 Commercial Blvd.
 Pevely, MO 63070

October 5, 2005
 Lab No. 05P-3096
 P.O. No. 21324
 Page 1 of 1

Attention: Chuck Ruud

REPORT OF CHARPY IMPACT TEST

MATERIAL (SAMPLE ID): WELD PLATE- 3018513 / 78308
SPECIFICATION: ASTM A 370-03a
SPECIMEN TYPE: "A" Vee Notch
SPECIMEN SIZE: 10 mm x 10 mm
TEMPERATURE OF TEST: -320°F
REQUIREMENTS: minimum 35 ft / lbs.

BASE METAL	FOOT LBS.	LATERAL EXPANSION	% SHEAR
3018513/78308-1	48	0.033	50
3018513/78308-2	65	0.045	50
3018513/78308-3	48	0.033	50
Average	54	0.037	50

Identification of tested specimen provided by client.

KS/tlv

 Karl Schmitz, Director
 Materials Testing



Certificate No. 0397-01
 Certificate No. 0397-02



Westmoreland Mechanical Testing & Research, Inc.

P.O. Box 388

Westmoreland Drive

Youngstown, Pa. 15696-0388 U.S.A.

Telephone: 724-537-3131 Fax: 724-537-3151

Website: www.wmtr.com

WMT&R is a technical leader in the material testing industry.



621-01 & 621-02

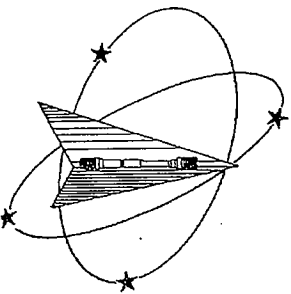

September 13, 2005

CERTIFICATION

MetalTek International
The Carondelet Division
8600 Commercial Blvd.
I-55 Industrial Park
Pevely, MO 63070-1528

Attention: Jim Galaske

Subject: All processes, performed upon the material as received, were conducted at WMT&R, Inc. in accordance with the WMT&R Quality Assurance Manual, Rev. 9, dated 4/1/2000.
The following tests were performed on this order: IMPACT and TENSILE

WMT&R Report No. 5-34328
P.O. No. 19386 Rel No.18
Requisition No. 4934

TENSILE RESULTS: ASTM E21-03a

Requirements: UTS ksi (Min 95\Max ---) 0.2% YS ksi (Min 72\Max ---) 4D Elong. % (Min 32\Max ---) Modulus Msi (Min 21\Max ---)

SOAK TIME: 5 Minutes

SPEED OF TESTING: 0.0030 in./in./min., 0.0500 in./min./in.

MATERIAL: 316 S/S

DISPOSITION: Acceptable

Reference	Lot No. Batch No. Specimen ID	TestLog Number	Temp. °F	UTS ksi	0.2% YS ksi	Elong %	RA %	Modulus Msi	Ult. Load lbf	0.2% YLD. lbf
Lincoln LNM4455	3018926 78309 Tensile	C43938	-320	182.1	128.2	34	24	27.0	17560	12360

AU/R: A=ACCEPTABLE, U=UNACCEPTABLE, R=REPORT

DISPOSITION: Acceptable

Reference	Lot No. Batch No. Specimen ID	TestLog Number	Orig. Dia. (in.)	Final Dia. (in.)	4D Orig GL (in.)	4D Final GL (in.)	Orig. Area (sq. in.)	Machine Number	AU/R
Lincoln LNM4455	3018926 78309 Tensile	C43938	0.3504	0.3048	1.40	1.87	0.09643131	M9	A

AU/R: A=ACCEPTABLE, U=UNACCEPTABLE, R=REPORT

Requirements supplied by MetalTek International.

Roy E. Starr / Matt Wojton
Technical Services Manager / Tensile Supervisor

9-13-05
September 13, 2005

KNOWINGLY OR WILLFULLY FALSIFYING OR CONCEALING A MATERIAL FACT ON THIS FORM OR MAKING FALSE, FICTITIOUS OR FRAUDULENT STATEMENTS OR REPRESENTATIONS HEREIN COULD CONSTITUTE A FELONY PUNISHABLE UNDER FEDERAL STATUTES. THIS CERTIFICATE OR REPORT SHALL NOT BE REPRODUCED EXCEPT IN FULL, WITHOUT THE WRITTEN APPROVAL OF WMTR, INC.

Testing Specialists for Aerospace, Automotive and Material Testing Fields
Locations in Youngstown, PA U.S.A. ~ Tel. (724) 537-3131 and
Banbury U.K. ~ Tel. +44 (0) 1295 261211

Westmoreland Mechanical Testing & Research, Inc.

P.O. Box 388

Westmoreland Drive

Youngstown, Pa. 15696-0388 U.S.A.

Telephone: 724-537-3131 Fax: 724-537-3151

Website: www.wmtr.com

WMT&R is a technical leader in the material testing industry.



621-01 & 621-02

CERTIFICATION

September 13, 2005

MetalTek International
The Carondelet Division
8600 Commercial Blvd.
I-55 Industrial Park
Pevely, MO 63070-1528

Attention: Jim Galaske

Subject: All processes, performed upon the material as received, were conducted at WMT&R, Inc. in accordance with the WMT&R Quality Assurance Manual, Rev. 9, dated 4/1/2000.
The following tests were performed on this order: IMPACT and TENSILE

WMT&R Report No. 5-34328

P.O. No. 19386 Rel No.18

Requisition No. 4934

IMPACT RESULTS: ASTM E23-02

REQUIREMENTS: Energy (Min 35\Max ---)

MATERIAL: Lincoln LNM4455

SAMPLE TYPE: Charpy V-Notch

DISPOSITION: Acceptable

Reference	Lot No. Batch No. Specimen ID	TestLog Number	Sample Size	Temp. °F	Energy ft-lbs	Mils Lat Exp	% Shear Fracture	AIUR
Lincoln LNM4455	3018926 78309 Cvn-1	C43939	Standard	-320	56	18	40	Acceptable
Lincoln LNM4455	3018926 78309 Cvn-2	C43940	Standard	-320	52	18	40	Acceptable
Lincoln LNM4455	3018926 78309 Cvn-3	C43941	Standard	-320	53	12	40	Acceptable

Requirements supplied by MetalTek International.

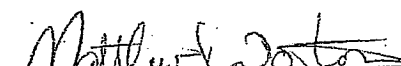
Roy E. Star, Matt Wojton
Technical Services Manager / Tensile Supervisor

9-13-05
September 13, 2005

KNOWINGLY OR WILLFULLY FALSIFYING OR CONCEALING A MATERIAL FACT ON THIS FORM OR MAKING FALSE, FICTITIOUS OR FRAUDULENT STATEMENTS OR REPRESENTATIONS HEREIN COULD CONSTITUTE A FELONY PUNISHABLE UNDER FEDERAL STATUTES. THIS CERTIFICATE OR REPORT SHALL NOT BE REPRODUCED EXCEPT IN FULL, WITHOUT THE WRITTEN APPROVAL OF WMT&R, INC.

Testing Specialists for Aerospace, Automotive and Material Testing Fields
Locations in Youngstown, PA U.S.A. ~ Tel. (724) 537-3131 and
Banbury U.K. ~ Tel. +44 (0) 1295 261211

11 B



2810 Clark Avenue • St. Louis, MO 63103-2574 • (314) 531-8080 • FAX (314) 531-8085

METALTEK INTERNATIONAL
8600 Commercial Blvd.
Pevely, MO 63070

April 6, 2005
Lab No. 05P-1007
P.O. No. 12516
Page 2 of 2

Attention: Chuck Ruud

REPORT OF CHARPY IMPACT TEST

MATERIAL (SAMPLE ID): (2) Metrode B316NF, Batch # WO19711

SPECIFICATION: ASTM A 370-03a

SPECIMEN TYPE: "A" Vee Notch

SPECIMEN SIZE: 10 mm x 10 mm

TEMPERATURE OF TEST: -320°F

ALL WELD METAL	FOOT LBS.	LATERAL EXPANSION	% SHEAR
B316NF-1	48	0.030	30
B316NF-2	52	0.027	30
B316NF-3	44	0.027	30
Average	48	0.028	30

Identification of tested specimen provided by client.

KS/tw

Karl Schmitz
Karl Schmitz, Director
Materials Testing



Certificate No. 0387-01
Certificate No. 0397-02

AN OFFICIAL COPY OF TEST REPORT WILL BE PROVIDED BY THIS LABORATORY ON REQUEST. DO NOT REPRODUCE.
NOT OFFICIAL WITHOUT THE RAISED SEAL OF ST. LOUIS TESTING LABORATORIES, INC.
SEE REVERSE FOR CONDITIONS.



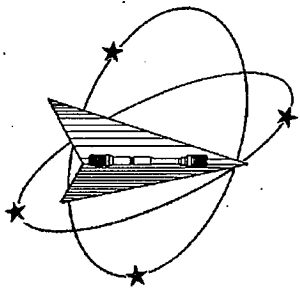

Westmoreland Mechanical Testing & Research, Inc.

P.O. Box 388

Westmoreland Drive

Youngstown, Pa. 15696-0388 U.S.A.

Telephone: 724-537-3131 Fax: 724-537-3151

Website: www.wmtr.com

WMT&R is a technical leader in the material testing industry.



621-01 & 621-02



September 9, 2005

CERTIFICATION

MetalTek International
The Carondelet Division
8600 Commercial Blvd.
I-55 Industrial Park
Pevely, MO 63070-1528

Attention: Jim Galaske

Subject: All processes, performed upon the material as received, were conducted at WMT&R, Inc. in accordance with the WMT&R Quality Assurance Manual, Rev. 9, dated 4/1/2000.
The following tests were performed on this order: TENSILE

Section 1 of 1

WMT&R Report No. 5-33240

P.O. No. 19386

Requisition No. 5813

TENSILE RESULTS: ASTM E21-03a

SOAK TIME: 5 Minutes

SPEED OF TESTING: 0.0030 in./in./min., 0.0500 in./min./in.

MATERIAL: METALTEK CF8MNMNMOD

DISPOSITION: Report

Coil No.	Specimen	TestLog Number	Temp. °F	UTS ksi	0.2% YS ksi	Elong %	RA %	Modulus Msi	Ult. Load lbf	0.2% YLD. lbf	Orig. Dia. (in.)	Final Dia. (in.)	4D Orig GL (in.)	4D Final GL (in.)	Orig. Area (sq. in.)	Machine Number	AIUR
C4	Z1	C35777	-320	166.5	100.2	58	50	26.8	33500	20150	0.5061	0.3584	2.00	3.16	0.20116969	M9	R
C4	Z2	C35778	-320	161.7	97.9	44	35	26.1	32550	19700	0.5062	0.4071	2.00	2.87	0.20124920	M9	R
C4	Z3	C35779	-320	166.2	95.4	60	56	26.5	33440	19200	0.5061	0.3354	2.00	3.20	0.20116969	M9	R

AIUR: A=ACCEPTABLE, U=UNACCEPTABLE, R=REPORT

KNOWINGLY OR WILLFULLY FALSIFYING OR CONCEALING A MATERIAL FACT ON THIS FORM OR MAKING FALSE, FICTITIOUS OR FRAUDULENT STATEMENTS OR REPRESENTATIONS HEREIN COULD CONSTITUTE A FELONY PUNISHABLE UNDER FEDERAL STATUTES. THIS CERTIFICATE OR REPORT SHALL NOT BE REPRODUCED EXCEPT IN FULL, WITHOUT THE WRITTEN APPROVAL OF WMT&R, INC.

Matthew Wojton
Roy E. Starr (Matt Wojton)
Technical Services Manager / Tensile Supervisor

9-9-05
September 9, 2005

Testing Specialists for Aerospace, Automotive, and Material Testing Fields
Locations in Youngstown, PA U.S.A. ~ Tel. (724) 537-3131 and
Banbury U.K. ~ Tel. +44 (0) 1295 261211

2810 Clark Avenue • St. Louis, MO 63103-2574 • (314) 531-8080 • FAX (314) 531-8085
 Chemical, Metallurgical, Mechanical, Nondestructive, Environmental Testing, Analyses and Field Service.

METALTEK INTERNATIONAL
 8600 Commercial Blvd.
 Pevely, MO 63070

August 10, 2005
 Lab No. 05P-2373
 P.O. No. 21324
 Page 1 of 3

Attention: CHUCK RUUD

REPORT OF CHARPY IMPACT TEST

MATERIAL (SAMPLE ID): Z1, Z2, Z3-C4 COIL- ALLOY CF8MNMnMod
SPECIFICATION: ASTM A 370-03a
SPECIMEN TYPE: "A" Vee Notch
SPECIMEN SIZE: 10 mm x 10 mm
TEMPERATURE OF TEST: +73°F
REQUIREMENTS: 50 ~~60~~ ft / lbs *Char 10/24/05*
RESULTS:

BASE METAL	FOOT LBS.	LATERAL EXPANSION	% SHEAR
Z1-7	164	0.086	80
Z1-8	170	0.084	80
Z1-9	160	0.081	80
Average	165	0.084	80
BASE METAL	FOOT LBS.	LATERAL EXPANSION	% SHEAR
Z2-7	168	0.091	90
Z2-8	146	0.084	80
Z2-9	164	0.111	90
Average	159	0.095	87
BASE METAL	FOOT LBS.	LATERAL EXPANSION	% SHEAR
Z3-7	180	0.091	90
Z3-8	204	0.100	90
Z3-9	224	0.106	90
Average	203	0.099	90

Identification of tested specimens provided by client.

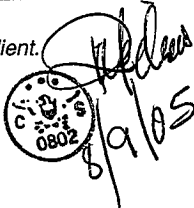

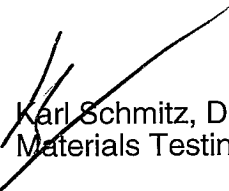
 Karl Schmitz, Director
 Materials Testing



Certificate No. 0397-01
 Certificate No. 0397-02

AN OFFICIAL COPY OF TEST REPORT WILL BE PROVIDED BY THIS LABORATORY ON REQUEST.
 NOT OFFICIAL WITHOUT THE RAISED SEAL OF ST. LOUIS TESTING LABORATORIES, INC.
 SEE REVERSE FOR CONDITIONS.



2810 Clark Avenue • St. Louis, MO 63103-2574 • (314) 531-8080 • FAX (314) 531-8085
 Chemical, Metallurgical, Mechanical, Nondestructive, Environmental Testing, Analyses and Field Service.

METALTEK INTERNATIONAL
 8600 Commercial Blvd.
 Pevely, MO 63070

August 10, 2005
 Lab No. 05P-2373
 P.O. No. 21324
 Page 2 of 3

Attention: CHUCK RUUD

REPORT OF CHARPY IMPACT TEST

MATERIAL (SAMPLE ID): Z1, Z2, Z3-C4 COIL- ALLOY CF8MNMnMod
SPECIFICATION: ASTM A 370-03a
SPECIMEN TYPE: "A" Vee Notch
SPECIMEN SIZE: 10 mm x 10 mm
TEMPERATURE OF TEST: 77°K
REQUIREMENTS: 35 ft / lbs
RESULTS:

BASE METAL	FOOT LBS.	LATERAL EXPANSION	% SHEAR
Z1-7	78	0.044	40
Z1-8	91	0.049	40
Z1-9	90	0.054	50
Average	86	0.049	43
BASE METAL	FOOT LBS.	LATERAL EXPANSION	% SHEAR
Z2-7	73	0.044	40
Z2-8	80	0.041	40
Z2-9	77	0.061	50
Average	77	0.049	43
BASE METAL	FOOT LBS.	LATERAL EXPANSION	% SHEAR
Z3-7	92	0.041	40
Z3-8	81	0.052	40
Z3-9	118	0.091	80
Average	97	0.061	53

Identification of tested specimens provided by client.

 8/10/05

 Karl Schmitz, Director
 Materials Testing



Certificate No. 0397-01
 Certificate No. 0397-02

AN OFFICIAL COPY OF TEST REPORT WILL BE PROVIDED BY THIS LABORATORY ON REQUEST.
 NOT OFFICIAL WITHOUT THE RAISED SEAL OF ST. LOUIS TESTING LABORATORIES, INC.
 SEE REVERSE FOR CONDITIONS.



2810 Clark Avenue • St. Louis, MO 63103-2574 • (314) 531-8080 • FAX (314) 531-8085
 Chemical, Metallurgical, Mechanical, Nondestructive, Environmental Testing, Analyses and Field Service.

METALTEK INTERNATIONAL
 8600 Commercial Blvd.
 Pevely, MO 63070

August 10, 2005
 Lab No. 05P-2373
 P.O. No. 21324
 Page 3 of 3
 (Corrected Report 8/12/05)

Attention: CHUCK RUUD

REPORT OF MECHANICAL TESTS

SAMPLE ID: Z1, Z2, Z3-C4 COIL- ALLOY CF8MNMnMod

Sample ID	Original Area Sq. Inches	Reduced Area Sq. Inches	Reduction in Area %	Yield Strength PSI	Tensile Strength PSI	Elongation (2.0" Gage Length)		Modules of Elasticity
						in.	%	
Z1	0.1893	0.0779	58.8	37400	82000	0.10	55.0	22.5 Msi
Z2	0.1893	0.0897	52.6	38400	83500	0.11	55.5	25.3 Msi
Z3	0.1893	0.0908	52.0	36500	83800	0.13	56.5	21.4 Msi

Round, reduced section tensiles
 Yield taken at .2% offset
 Tested in accordance with ASTM A 370-03a

Identification of tested specimens provided by the client.
Room temperature Ctr 8/20/05

 Karl Schmitz, Director
 Materials Testing

KS/tlv



Certificate No. 0397-01
 Certificate No. 0397-02

AN OFFICIAL COPY OF TEST REPORT WILL BE PROVIDED BY THIS LABORATORY ON REQUEST.
 NOT OFFICIAL WITHOUT THE RAISED SEAL. **25** ST. LOUIS TESTING LABORATORIES, INC.
 SEE REVERSE FOR CONDITIONS.



Coil C-4 Weld Map – Metal Tek

Map of all major welds exceeding 20% of wall, over 1 inch or over 10² inches

Defect Number	Drawing View	Length (inches)	Width (inches)	Depth (inches)
1	Left	4 ³ / ₄	4 ¹ / ₂	1 ¹ / ₂
2	Left	6 ¹ / ₂	6	1
3	Left	4 ³ / ₄	4 ¹ / ₂	1
4	Left	20	10 ¹ / ₂	1 ¹ / ₄
5	Left	8	3	¹ / ₂
6	Left	13	2	¹ / ₂
7	Left	6 ¹ / ₂	4 ³ / ₄	¹ / ₄
8	Left	9	3	¹ / ₄
9	Left	19	2	¹ / ₄
10	Left	8 ¹ / ₂	4	¹ / ₄
11	Left	15	2	¹ / ₂
12	Left	18	10	³ / ₄
13	Left	3	2	2
14	Left	4 ¹ / ₂	1 ³ / ₄	1 ¹ / ₂
15	Left	5	4	¹ / ₄
16	Left	10	5	¹ / ₄
17	Left	9	1 ¹ / ₂	¹ / ₄
18	Left	10 ³ / ₄	1	¹ / ₂
19	Left	8	3	¹ / ₄
20	Left	12	6	Thru
21	Top	5	5	¹ / ₂
22	Bottom	10 ¹ / ₂	6	³ / ₄
23	Bottom	13	5	Thru
24	Bottom	7	2 ¹ / ₂	Thru
25	Bottom	6	3 ¹ / ₄	³ / ₄
26	Bottom	12	8	³ / ₄
27	Bottom	14	7	1
28	Back	10	4	1 ¹ / ₂
29	Back	11	2	2
30	Back	4	2 ¹ / ₂	Thru
31	Back	23	5 ¹ / ₂	1
32	Back	10	6	1
33	Back	12	2 ¹ / ₂	Thru
34	Back	2	2	1
35	Back	13	2	1 ³ / ₄

Coil C-4 Weld Map – Metal Tek

Map of all major welds exceeding 20% of wall, over 1 inch or over 10² inches

Defect Number	Drawing View	Length (inches)	Width (inches)	Depth (inches)
36	Back	16	1	¼
37	Back	9	5	Thru
38	Back	3	3	1
39	Back	8	4 ½	¾
40	Back	7	2	2
41	Back	3	2	1 ½
42	Top	10	2	1 ¾
43	Top	5	2	1 ½
44	Top	7	1 ½	1
45	Top	8	2	1
46	Front	7 ½	7	3
47	Front	22 ½	10	2
48	Front	15	6	4
49	Front	8 ½	4	3
50	Front	9	4	1 ½
51	Front	6 ½	5	¾
52	Front	6	3	1
53	Front	14	6	1 ½
54	Front	10	4	Thru
55	Front	5	3 ½	Thru
56	Front	7 ½	4 ½	1
57	Front	3 ½	3 ½	2
58	Front	6	4	¾
59	Front	13	5	¾
60	Front	3 ½	3 ½	2
61	Front	9	7 ½	½
62	Front	12	1	¾
63	Front	8	4	1 ½
64	Front	3	2	Thru
65	Front	6	3 ½	Thru
66	Front	13	3	Thru
67	Front	31	12	1
68	Front	6	3 ½	2
69	Bottom	8	2 ¾	1 ½
70	Right	7	4	1
71	Right	3	2	1
72	Right	9	6	3

Coil C-4 Weld Map – Metal Tek

Map of all major welds exceeding 20% of wall, over 1 inch or over 10² inches

Right View

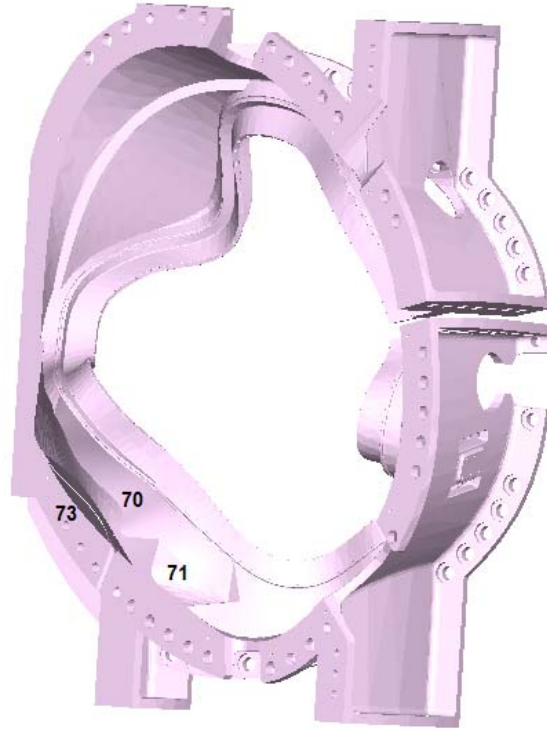

Coil C-4 Weld Map – Metal Tek

Map of all major welds exceeding 20% of wall, over 1 inch or over 10² inches

Front View

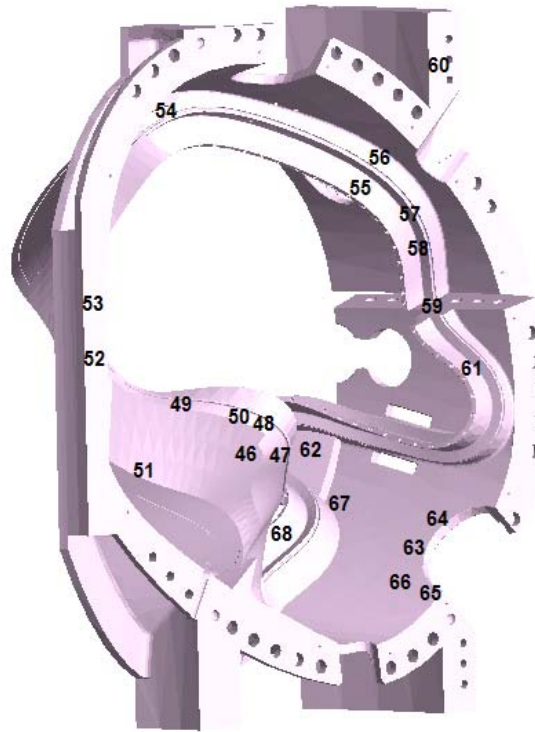

Coil C-4 Weld Map – Metal Tek

Map of all major welds exceeding 20% of wall, over 1 inch or over 10² inches

Back View

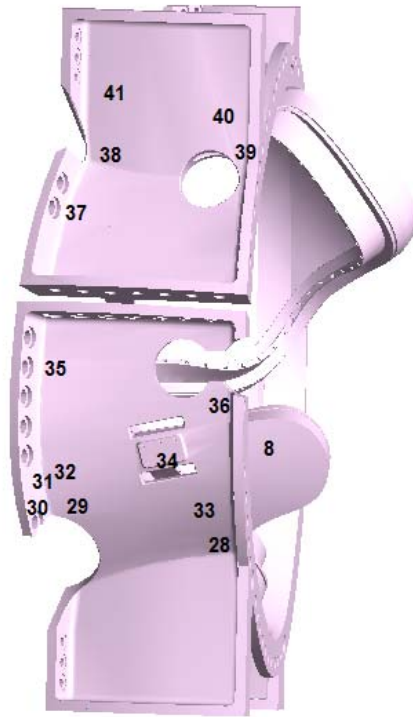

Coil C-4 Weld Map – Metal Tek

Map of all major welds exceeding 20% of wall, over 1 inch or over 10² inches

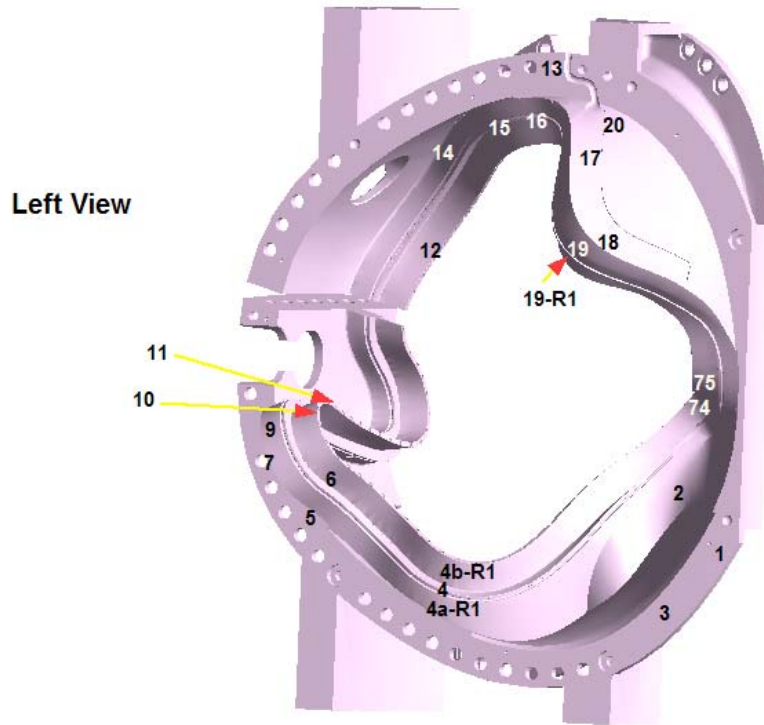

Coil C-4 Weld Map – Metal Tek

Map of all major welds exceeding 20% of wall, over 1 inch or over 10² inches

Top View

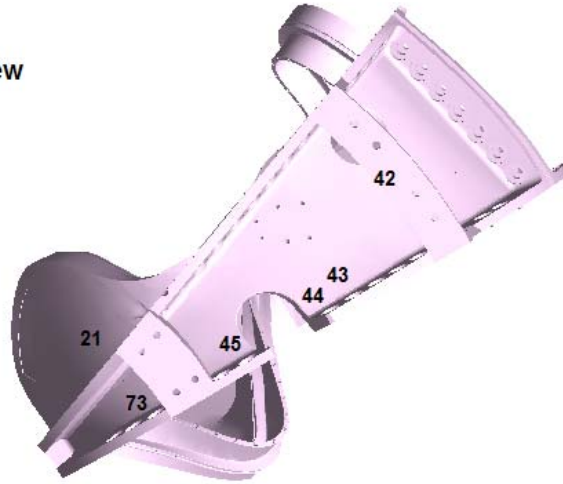

Coil C-4 Weld Map – Metal Tek

Map of all major welds exceeding 20% of wall, over 1 inch or over 10² inches

Bottom View

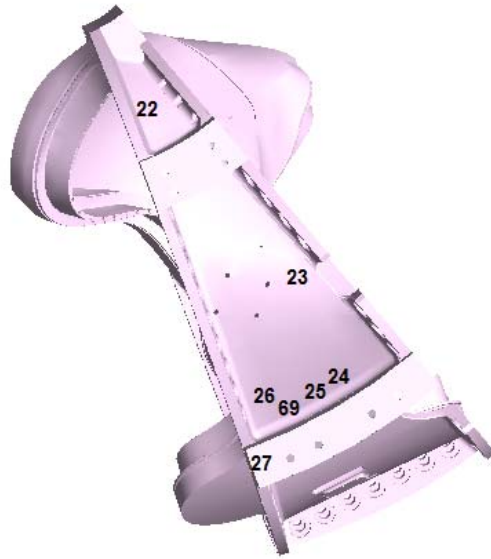

RADIOGRAPHIC STANDARD SHOOTING SKETCH

Customer EIO	Pattern Number MCWF-C-4
Material CF8MNM	Traceability Number
Film Manufacturer Fuji	Source Number 23ci 060
IQI LEVEL <u>2-2T</u> From CQP 401 <input checked="" type="checkbox"/> Other (Specify, E.G. 2-4T, 2-1T) <u>N/A</u>	

Exposures (views)	75-76	92-93	116-117	B-C	C-D	E-F	F-G	G-H	H-I	I-J		
Thickness (IN.)	1 1/2" x 2"	1 1/2" x 2"	2 3/4"	3"-6"	3"-8"	3"-8"	3"-6"	3"-6"	3"-6"	3"-6"		
S/F Distance (IN.)	20"	→ 15"	20"							→		
Penetrator	30/40	→ 50x2	60x2 120x2	60x2 120x2 140	→ 60x2 120x2	60x2 80 120x2	60x2 120x2	→				
Time (MIN.)	7m	6m30s	10m	1hr45m	→ 1hr45m					→		
Focal Spot (IN.)	1									→		
Film Size (IN.)	14x17									→		
Screen Size (Pb) Front/Back	.01									→		
S.W.E./D.W.E.	SWE									→		
S.W.V./D.W.V.	SWV									→		
Film Type	59/150	→ 89/150	29 5/8 x 29 1/2							→		
Acceptance Standard	E446	→ E186	E186 E250							→		
Severity Level	See spec	spec	SP 54							→		

Shooting Sketch (Use Additional Pages as Needed)

See original Tech. Drawing

Technique Prepared By: Dave [Signature] Level: II
 Technique Approved By: [Signature] Level: III

Date: 10-24-05
 Date: 10-24-05

TEAM COOPERHEAT-MQS, INC.

CERTIFIED RADIOGRAPHIC INSPECTION REPORT

FORM 6061-RT- 002 Rev.2

5512 W. State St. Milwaukee, WI 53208 Tel:(414)771-3060 Fax:(414)771-9481 (800)818-6403 www.cooperheat-mqs.com

CUSTOMER		DATE	WORK ORDER NO.
NAME METAL TEK INTERNATIONAL		8/13/2005	361-02454-2
ADDRESS 8600 COMMERCIAL BLVD		P.O. NUMBER	XRAY X
CITY PEVELY STATE MO ZIP 63070		21678	GAMMA
PROCEDURE SPECIFICATION ASTM E94-93	ACCEPTANCE CRITERIA MSS-SP-54-1999	SHEET 1 OF 6	

PART NUMBER	Serial No	View	No Apparent Indications		Dross		Incomplete Penetration		Shrinkage		Film Artifacts		REMARKS
			Acceptable	Rejected	Inclusion	Porosity	Lack of Fusion	Gas Cracks	Hot Tears	Undercut	Surface		
MCWF-C-4		1-2		R				3-4					
		2-3	✓					1					
E.I.O. C040851		3-4	✓					2					
		4-5	✓					2				✓	
MS75920-4		5-6	✓					2				✓	
		7-8	✓									✓	
		8-9	✓									✓	
		9-10		R				3-4					See Also ✓ 39-40
		11-12	✓										
		12-13	✓									✓	
		13-14	✓									✓	*
		15-16		R				4					
		16-17	✓					1-2				✓	
		18-19	✓									✓	
		19-20	✓									✓	✓
		20-21	✓									✓	
		21-22	✓					2	1			✓	
		23-24	✓						0-1			✓	
		24-25	✓									✓	
		26-27	✓									✓	
		27-28	✓					2-3				✓	
		29-30	✓						2			✓	✓
		30-31	✓					1				✓	
		32-33	✓					1	1			✓	
		33-34	✓									✓	

NO. ACCEPTED	0	NO. REJECTED	1	MQS TECH. NO.	12970	SHT.	REV. 1
COMMENTS	* added Film + 60 Pen for surface feature			CUST. RSS NO.		SHT.	REV.
				REVIEWER	John Petroski		
				CERTIFIED NOT LEVEL (RT)	RT-II		

TEAM COOPERHEAT-MQS, INC.

CERTIFIED RADIOGRAPHIC INSPECTION REPORT

FORM 6061-RT- 002 Rev.2

5512 W. State St. Milwaukee, WI 53208 Tel:(414)771-3060 Fax:(414)771-9481 (800)818-6403 www.cooperheat-mqs.com

CUSTOMER		DATE	WORK ORDER NO.
NAME METAL TEK INTERNATIONAL		8/13/2005	361-02454-2
ADDRESS 8600 COMMERCIAL BLVD		P.O. NUMBER	XRAY X
CITY PEVELY STATE MO ZIP 63070		21678	GAMMA
PROCEDURE SPECIFICATION ASTM E94-93	ACCEPTANCE CRITERIA MSS-SP-54-1999	SHEET <u>2</u> OF <u>6</u>	

PART NUMBER	Serial No	View	No Apparent Indications		Incomplete Penetration		Shrinkage		Film Artifacts		REMARKS
			Acceptable	Rejection	Dross or Slag	Porosity	Lack of Fusion Gas Cracks	Hot Tears	Under cut	Surface	
MCWF-C-4	3536	✓									
	3637			R				3-4			
E.I.O. C040851	3839			R					R		
	3940			R				4			See Also V9/10
MS75920-4	4142			R				3			
RBK	4243			R					4-5		
RBK	4445	✓							110*		
Re Test RBK	4546	✓		R				4			
	4748			R					R		
	4849			R					R		
	49-50-51	✓									
	5253	✓									
	5354	✓									
	* 5455	✓									
	5556			R					2-3		
	5657	✓									
	5758	✓									
	5859	✓									
	5960	✓									
	6061	✓									
	6263	✓									
	6364			R					R		
	6566			R					3-4		
	6768			R					R		
	6869	✓									

NO. ACCEPTED	0	NO. REJECTED	1	MQS TECH. NO.	12970	SHT.	REV. 1
COMMENTS	* R.S. when returned for upgrade 40 Pins not present.			CUST. RSS NO.		SHT.	REV.
				REVIEWER	<i>John Petrucci</i>		
				CERTIFIED NDT LEVEL (RT)	RT II		

TEAM COOPERHEAT-MQS, INC.

CERTIFIED RADIOGRAPHIC INSPECTION REPORT

FORM 6061-RT- 002 Rev.2

5512 W. State St. Milwaukee, WI 53208 Tel:(414)771-3060 Fax:(414)771-9481 (800)818-6403 www.cooperheat-mqs.com

CUSTOMER		DATE	WORK ORDER NO.
NAME METAL TEK INTERNATIONAL		8/13/2005	361-02454-2
ADDRESS 8600 COMMERCIAL BLVD		P.O. NUMBER	XRAY X
CITY PEVELY STATE MO ZIP 63070		21678	GAMMA
PROCEDURE SPECIFICATION ASTM E94-93	ACCEPTANCE CRITERIA MSS-SP-54-1999	SHEET <u>3</u> OF <u>6</u>	

PART NUMBER	Serial No	View	No Apparent Indications		Incomplete Penetration		Shrinkage		Film Artifacts		REMARKS
			Acceptable	Rejected	Inclusion or Slag	Porosity	Lack of Fusion Gas Cracks	Hot Tears	Under cut	Surface	
MCWF-C-4	6970	✓					1-2		✓		
	*										
E.I.O. C040851	7172	✓					1-2		✓		
	7273	✓									
MS75920-4	7374			R			3				
	7475	✓							✓		
	7576	✓		R			2-3		✓		
	7677	✓							✓	✓	
	7879			R			4-5				
	7980			R			5				
	8081	✓					1-2		✓		
	8182	✓					0-1	1-2	✓		
	8384			R			4-5		✓		
	8586			R				R	✓		
	8687	✓					0-1		✓	**	
	8788	✓							✓		
	9091	✓							✓		
	9293			R				R	✓		
	8889	✓							✓		
	V94	✓					2			✓	
	V95	✓			1				✓		
	9697			R			5	Visible to surface	✓		
	9798			R				R	✓	✓	
	9899	✓							✓		
	100-101	✓					1				

NO. ACCEPTED	0	NO. REJECTED	1	MQS TECH. NO.	12970	SHT.	REV. 1
COMMENTS*	No V64 - Not needed, Dig out view from previous Pc.			CUST. RSS NO.		SHT.	REV.
**	Three additional Film used for density.			REVIEWER	<i>John Petrucci</i>		
				CERTIFIED NDT LEVEL (RT)	RT-II		

TEAM COOPERHEAT-MQS, INC.

CERTIFIED RADIOGRAPHIC INSPECTION REPORT

FORM 6061-RT- 002 Rev.2

5512 W. State St. Milwaukee, WI 53208 Tel:(414)771-3060 Fax:(414)771-9481 (800)818-6403 www.cooperheat-mqs.com

CUSTOMER		DATE	WORK ORDER NO.
NAME <u>METAL TEK INTERNATIONAL</u>		<u>8/13/2005</u>	<u>361-02454-2</u>
ADDRESS <u>8600 COMMERCIAL BLVD</u>		P.O. NUMBER	XRAY X
CITY <u>PEVELY</u> STATE <u>MO</u> ZIP <u>63070</u>		<u>21678</u>	GAMMA
PROCEDURE SPECIFICATION	ACCEPTANCE CRITERIA	SHEET <u>4</u> OF <u>6</u>	
ASTM E94-93	MSS-SP-54-1999		

PART NUMBER	Serial No	View	No Apparent Indications		Incomplete Penetration		Shrinkage		Film Artifacts		REMARKS
			Acceptable	Rejected	Dross or Slag	Porosity	Lack of Fusion Gas Cracks	Hot Under Tears	Surface cut		
MCWF-C-4	101-102			R				45	45		
	102-103			R					R	✓	
E.I.O. C040851	103-104			R					R	✓	
	104-105			R					R		✓
MS75920-4	106-107			R			3-4		R	✓	
	107-108			R				3-4		✓	
	108-109										
	109-110	✓							1		
	111-112	✓									
	112-113	✓									
	114-115			R					45		
	115-116	✓									
	116-117			R					45 R		

NO. ACCEPTED <u>0</u>	NO. REJECTED <u>/</u>	MQS TECH. NO. 12970	SHT.	REV. 1
COMMENTS		CUST. RSS NO.	SHT.	REV.
		REVIEWER <u>Joh. Petrucci</u>		
		CERTIFIED NDT LEVEL (RT)		
		<u>RT II</u>		

TEAM COOPERHEAT-MQS, INC.

CERTIFIED RADIOGRAPHIC INSPECTION REPORT

FORM 6061-RT- 002 Rev.2

5512 W. State St. Milwaukee, WI 53208 Tel:(414)771-3060 Fax:(414)771-9481 (800)818-6403 www.cooperheat-mqs.com

CUSTOMER		DATE	WORK ORDER NO.
NAME METAL TEK INTERNATIONAL		8/13/2005	361-02454-2
ADDRESS 8600 COMMERCIAL BLVD		P.O. NUMBER	XRAY X
CITY PEVELY STATE MO ZIP 63070		21678	GAMMA
PROCEDURE SPECIFICATION ASTM E94-93	ACCEPTANCE CRITERIA MSS-SP-54-1999	SHEET 5 OF 6	

PART NUMBER	Serial No	View	No Apparent Indications		Dross		Incomplete Penetration		Shrinkage		Film Artifacts		REMARKS
			Acceptable	Rejected	Inclusion	Porosity	Lack of Fusion	Gas Cracks	Hot Tears	Under cut	Surface		
MCWF-C-4		A-B		R					4-5				
RAIL		B-C		R					4-5			✓	
E.I.O. C040851		C-D		R					4-5			✓	
		D-E	✓									✓	
MS75920-4		E-F	✓	R					3-4			✓	
		F-G		R					3-4				
		G-H		R					4-5				
		H-I		R					5				
		I-J		R					5				
		J-K		R					4			✓	
		K-L	✓									✓	
		L-M	✓									✓	
		M-N	✓						0-1			✓	
		N-O	✓									✓	
		O-P	✓						0-1	Z			
		P-Q	✓										
		Q-R	✓						0-1			✓	
		R-S		R					4-5				
		S-T		R							R		
		T-U	✓						0-1			✓	
		U-V	✓						2			✓	✓
		V-W	✓						1			✓	
		W-X	✓						2-3			✓	
		X-Y	✓						1			✓	
		Y-Z		R					4			✓	

NO. ACCEPTED	φ	NO. REJECTED	1	MQS TECH. NO.	12970	SHT.	REV. 1
COMMENTS				CUST. RSS NO.		SHT.	REV.
				REVIEWER	<i>h. Petroski</i>		
				CERTIFIED NDT LEVEL (RT)	RT II		

TEAM COOPERHEAT-MQS, INC.

CERTIFIED RADIOGRAPHIC INSPECTION REPORT

FORM 6061-RT- 002 Rev.2

5512 W. State St. Milwaukee, WI 53208 Tel:(414)771-3060 Fax:(414)771-9481 (800)818-6403 www.cooperheat-mqs.com

CUSTOMER		DATE	WORK ORDER NO.
NAME METAL TEK INTERNATIONAL		10/09/2005	361-02596
ADDRESS 8600 COMMERCIAL BLVD		P.O. NUMBER	XRAY X
CITY PEVELY STATE MO ZIP 63070		22184	GAMMA
PROCEDURE SPECIFICATION	ACCEPTANCE CRITERIA	SHEET ____ OF ____	
ASTM E94-93	MSS-SP-54-1999*	NCSX-CSPEC-141-03-08 Ref Para. 3.1.1.7	

PART NUMBER	Serial No	View	No Apparent Indications		Incomplete Penetration		Shrinkage		Film Artifacts		REMARKS
			Acceptable	Rejected	Inclusion or Porosity	Lack of Fusion Gas Cracks	Hot Tears	Under surface			
MCWF-C-4	4 (RI)	1-2	✓								
	* 4-5		✓								
E.I.O. C040851	* 5-6		✓								✓
	9-10		✓					1-2			
MS75920-4	15-16		✓					1			✓
	36-37		✓								✓
	38-39		✓								
	39-40		✓								
	41-42		✓								
	42-43		✓								✓
	45-46		✓							✓	
	47-48		✓								
	48-49		✓		✓						
	53-56		✓								
	63-64		✓					1-2			
	65-66		✓								✓
	67-68		✓								
	73-74		✓								
	75-76			R							
	78-79		✓								
	79-80		✓								
	83-84		✓		2-3						
	85-86		✓								
	92-93			R				R			
	96-97		✓								✓

NO. ACCEPTED	NO. REJECTED	MQS TECH. NO.	SHT.	REV.
0	1	12970		
COMMENTS		CUST. RSS NO.	SHT.	REV.
		REVIEWER		
		CERTIFIED NDT LEVEL (RT)		
		John Petroske RT II Exp. 01/08		

TEAM COOPERHEAT-MQS, INC.

CERTIFIED RADIOGRAPHIC INSPECTION REPORT

FORM 6061-RT- 002 Rev.2

5512 W. State St. Milwaukee, WI 53208 Tel:(414)771-3060 Fax:(414)771-9481 (800)818-6403 www.cooperheat-mqs.com

CUSTOMER		DATE	WORK ORDER NO.
NAME METAL TEK INTERNATIONAL		10/09/2005	361-02596
ADDRESS 8600 COMMERCIAL BLVD		P.O. NUMBER	XRAY X
CITY PEVELY STATE MO ZIP 63070		22184	GAMMA
PROCEDURE SPECIFICATION	ACCEPTANCE CRITERIA	SHEET ____ OF ____	*NCSX-CSPEC-141-03-08 Ref Para. 3.1.1.7
ASTM E94-93	MSS-SP-54-1999 *		

PART NUMBER	Serial No	View	No Apparent Indications		Dross		Incomplete Penetration		Shrinkage		Film Artifacts		REMARKS
			Acceptable	Rejected	Included	or Porosity	Lack of Fusion	Gas Cracks	Hot Tears	Under cut	Surface		
MCWF-C-4	4 (RI)	97-98	✓										
		101-102	✓										✓
E.I.O. C040851		102-103	✓										✓
		103-104	✓										✓
MS75920-4		104-105	✓										
		106-107	✓										
		107-108	✓										
		114-115	✓										
		116-117			R					4			
		A-B	✓						1				
	*	B-C			R					2			
	*	C-D			R				1				
	*	F-G			R				2				
	*	G-H			R				2				
	*	H-I			R				5				
		E-J			R				45				
		J-K	✓						1				
		R-S	✓							1			
		S-T	✓							1			
		V-Z	✓						2				
		Z-AA	✓										
		CC-DD	✓						1				
		DD-A	✓						1				

NO. ACCEPTED	0	NO. REJECTED	1	MQS TECH. NO.	12970	SHT.	REV.
COMMENTS				CUST. RSS NO.		SHT.	REV.
				REVIEWER	<i>John Petroske</i>		
				CERTIFIED NDT LEVEL (RT)			
				John Petroske	RT II Exp. 01/08		

MetalTek

INTERNATIONAL

RADIOGRAPHIC INTERPRETATION REPORT

CUSTOMER E.I.O		PURCHASE ORDER NUMBER PPPL-FP-LTS-2			DATE 10-24-05		CONTROL NO. 40851		PAGE 1 of 1														
PART NO. MCWF-C-4		SPECIFICATION E44/E184/E280			CLASS See Spec.		TOTAL PIECES 1		PIECES ACCEPTED														
RADIOGRAPHED BY: Midgett/Kelley				INTERPRETED BY: Midgett/Kelley				ASNT LEVEL #															
FILM TYPE 29/59/80		MATERIAL CF8MMN			ISOTOPE IRIDIUM 192 COBALT 60 /			CODE ASTM E94 / ASME MIL-STD-453															
		V I E W		P E N E		A C C E P T		R E J E C T		S H R I N K		I N C L U S I O N		P O R O S I T Y		L I N E A R		S U R F A C E		L O F / L O P		COMMENTS	
MS75920-4																							
MCWF-C-4		75-76		30/40		/								2		/							
R2		92-93		↓		/								1		/							
		116-117		50		/								2		/							
		B-C		60/120				X						X									
		F-G		↓		/								1		/							
		G-H		60/80/120				X		UBK				X									
		H-I		60/120				X		X		X											
		I-J		↓		/								2		/							
		C-D		60/120/140		/								1									
		E																					
R1		E-F		60/120/140		/						1		2									

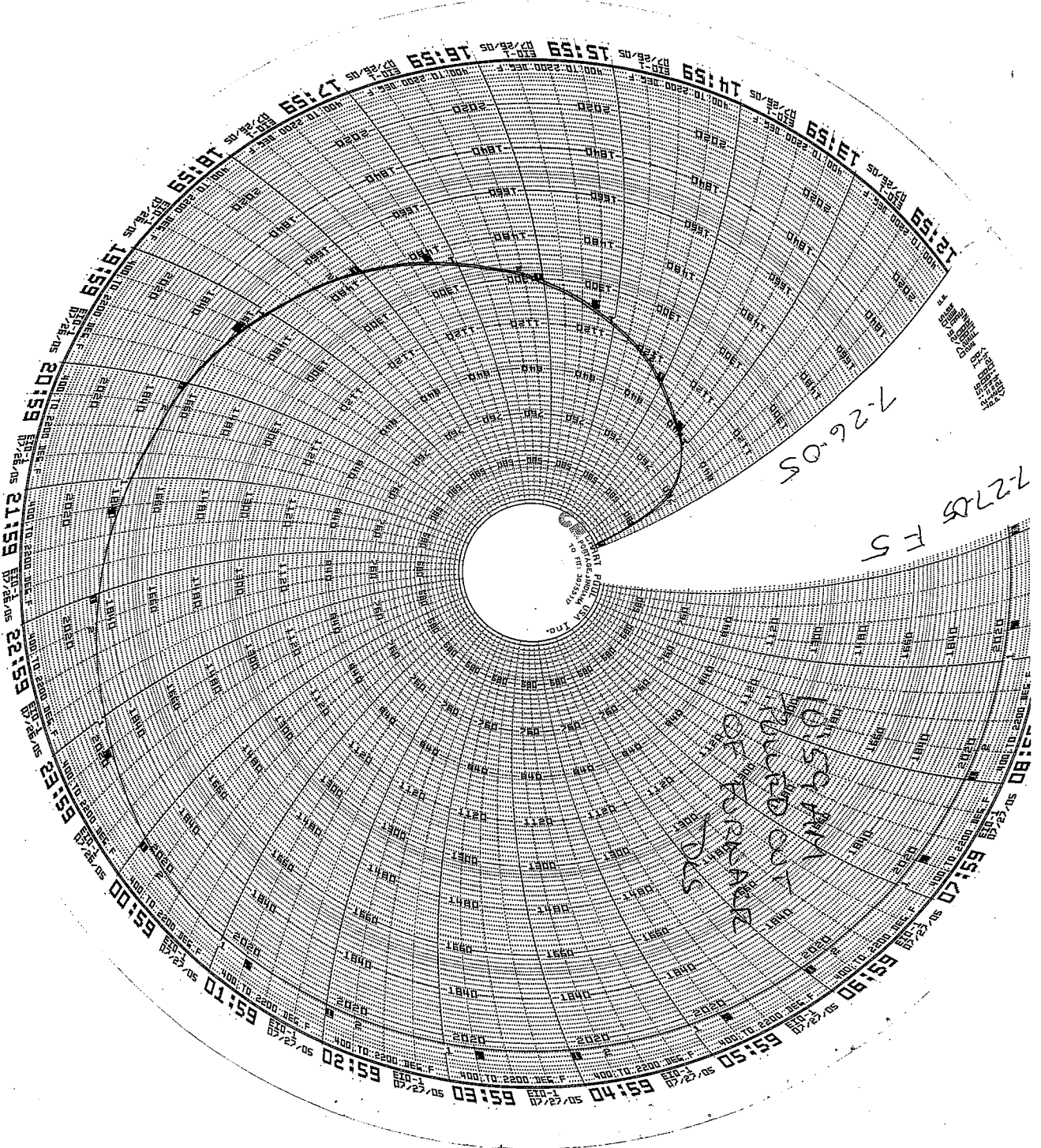

E10 7-26-05
 MCVF-C4
 MS75920-3
 IPc

A+C Shims etc

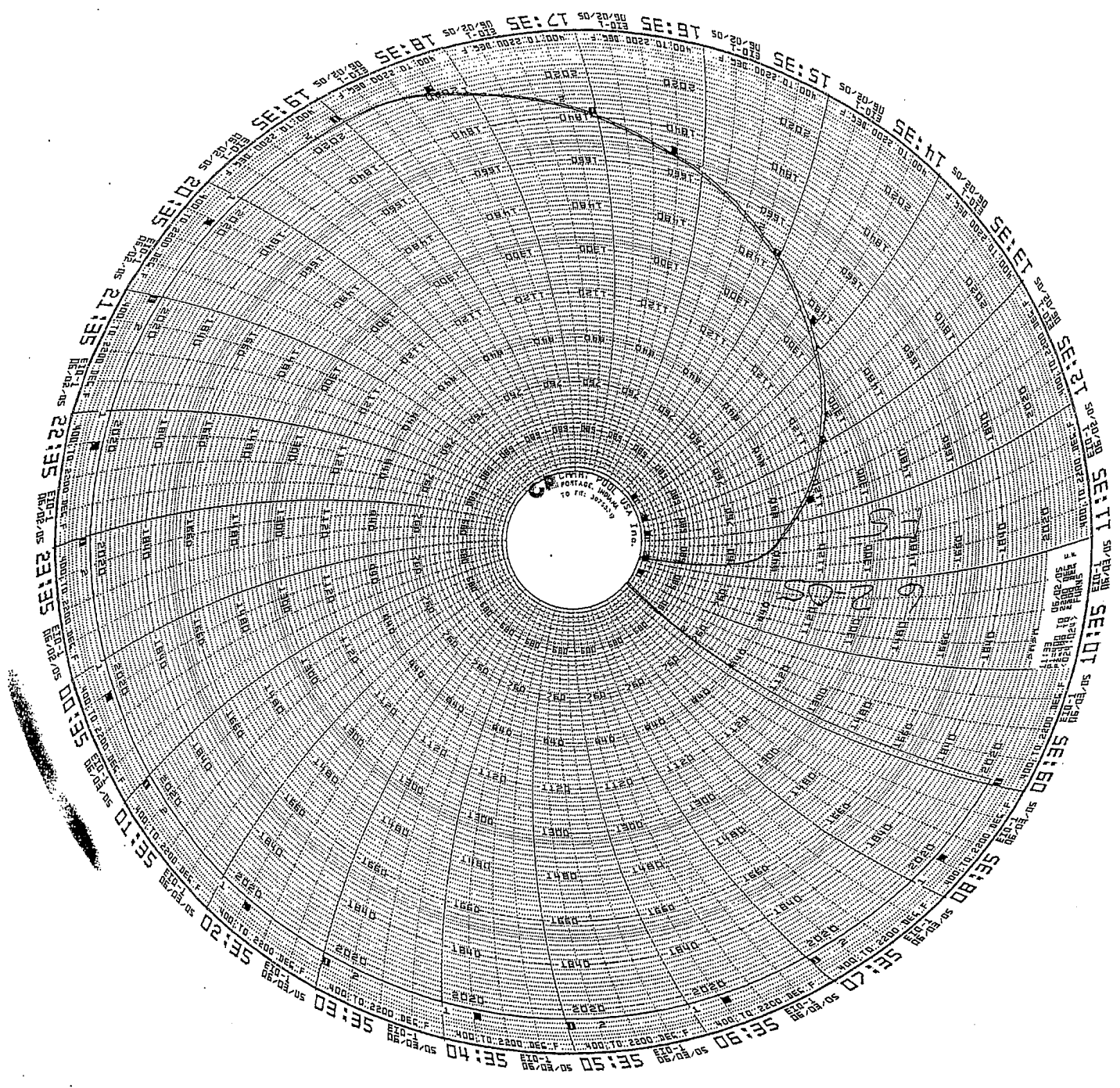

Energy Industries of Ohio

Manufacturing and Test Sequence (MTS) Serial Number C-4

1 OF 10 CO# 40851 Dated 3-9-05 Revision: Rev 7 Dated Issued: 6-14-05

OPER. #	STATION	DESCRIPTION OF PROCESS	Name	Date
10	QUALITY RELEASE	REVIEW AND APPROVE MTS. RECEIVED APPROVAL FROM EIO ON <u>6/14/05</u> FROM <u>Pete</u> SIGNED QUALITY MANAGER	CAJ	6/14
15	PATTERN NPAT SOP 0100REV2	APPLY APPROPRIATE PART NUMBER, SERIAL NUMBER, AND FOUNDRY MARK, TO THE PATTERN. CAST ON BARS REQUIRED. Place numbers on the bars as to their location.		
20	COREMAKE CORE SOP 0100 REV 6 CALIBRATION PER CORE SOP 0200R4/0300R6	MAKE CORES IN SAND MIXTURES AS DESCRIBED BY METALTEK ENGINEERING AND VERIFIED IN MODELING TRIALS. METALTEK CORE SOP 0100 REV 6) CORE WASH WITH ZIRCONIUM CORE WASH. (CALIBRATION OF EQUIPMENT REQUIRED PER CORE SOP 0200,R4 / 0300,R6) VERIFY COUNT AND INSPECT.	Bwe	7-8-05
30	MOLD MOLD SOP 0400 REV 8 CALIBRATION PER MOLD SOP 0900 REV 5 PREPARATION PER MOLD SOP 1100R2/1200R2/1300R1 SAND TESTING PER MOLD SOP 1400R2/1500R3/1600R2	MOLD PER WORK INSTRUCTIONS IN MAPICS ROUTING AND SOPS REFERENCED. ENGINEER OF RECORD - ROGER BROMAN, CONSULT ON MOLD-RELATED CONCERNS. MOLD MATERIALS REQUIRED PER MAPICS BOM. NOTIFY ENGINEER OF ANY SUBSTITUTIONS.	Bwe	7-8-05
40	POUR MELT SOP 0100R5 MELT SOP 0700R2 MELT SOP 0600R2	METAL MUST BE AOD REFINED OR AOD INGOT. VIRGIN METAL ADDITIONS ALLOWED. RECORD POURING TEMPERATURE: <u>2750</u> CASTING POURED AT: <u>NBF 7-13-05 6:30 AM</u> DATE: <u>7-13-05</u> HEAT #'s: <u>30108, 30109, 30110, 30111, 30112, 30113</u> ELAPSED POUR TIME <u>10 min</u> KEEL BLOCKS POURED: <u>yes - 8</u> Sample from ladle to be analyzed for final chemical analysis and reported on material certifications. Sample Taken by: <u>J.W.</u> Analyzed: <u>G. Hurt</u> Date: <u>7-13-05</u>	JWG	7-13-05
50	MELT SOP 0800R2	SHAKEOUT	CAJ	7-16-05

Energy Industries of Ohio
Manufacturing and Test Sequence (MTS) Serial Number C-4

2 OF 10 CO# 40851 Dated 3-9-05 Revision: Rev 7 Dated Issued: 6-14-05

60	ARC RISE SOP 0100R1	REMOVE RISERS AS DIRECTED BY SUPERVISOR.	<i>OK</i>	<i>7/25</i>
70	HEAT TREAT HEAT SOP 0103R5	SOLUTION ANNEAL. MAKE SURE TO BLOCK ALL FLANGES OF FORM AND RACETRACK TO MINIMIZE CREEP DISTORTION. Soak Temp: 2050F, Soak Time: 4HR + 1/2 HR/IN, Quench Type: Air Cool	<i>FS-1 Kmr</i>	<i>7/26</i>
75	PHYSICAL TESTING	OBTAIN TEST SPECIMENS AND SUBMIT FOR PHYSICAL TESTING. REPORT RESULTS AS PART OF STEP 510.	<i>W#</i>	<i>7/26</i>
NOTE		THE ORDER OF CLEANING PROCESSES MAY BE ALTERED DUE TO CAPACITY CONSTRAINTS. HOLD POINTS AND COMPLIANCE WILL NOT BE COMPROMISED. EIO WILL BE ADVISED OF ALL CHANGES THAT MAY RESULT IN A REQUEST FOR DEVIATION FROM REQUIREMENTS.		
80	GRIND GSA SOP 0100R3	SWING GRIND TO REMOVE RISER REMAINS AND FLASH IF REQUIRED.	<i>MHW</i>	<i>8/2</i>
85	GRIND GCHI SOP 0100R2	CHIP AND HAD GRIND SURFACE OF PART AS REQUIRED FOR CONTOUR.		
90	SAND BLAST BLAS SOP 0100R6	SANDBLAST (REMOVE ALL BLAST MATERIAL FROM CASTING) SANDBLASTING WILL BE DONE USING RECYCLED SHARP ANGULAR AGGREGATE.		
NOTICE	WITNESS NOTIFICATION HOLD FOR EIO APPROVAL	PROVIDE NOTICE TO EIO AND DCMA AT LEAST FIVE DAYS IN ADVANCE OF LAYOUT. EIO NOTIFIED ON <u>7/28/05</u> DCMA NOTIFIED ON <u>7/28/05</u> APPROVAL RECEIVED ON _____ <i>Romer</i>	Q ENG OR QA MGR	
100	LAYOUT SOP LAYOUT 0100	INSPECT CASTING TO VERIFY DIMENSIONS. THIS STEP MAY BE DELAYED. DIMENSIONED _____ DATE _____ RELEASED _____ (ENGINEER ONLY) NOTE: THE FIRST PART PRODUCED OF EACH TYPE A, B AND C WILL BE DIMENSIONED BY LAWTON PATTERN. IF DIMENSIONED BY LAWTON IT WILL BE DOCUMENTED HERE. Subsequent casting done internally per Romer Arm.		
110	VISUAL INSPECTION CQP-500 REV 4	VISUALLY INSPECT 100% of COMPONENT ACCORDING TO ASTM A802 LEVEL 3 ALL CONDITIONS. IF OK CHECK HERE _____ IF REJECTED CHECK HERE ____ . MARK AND REPAIR AT STEP 120.	VT - LEVEL II	

*start
Rev 8*

**Energy Industries of Ohio
Manufacturing and Test Sequence (MTS) Serial Number C-4**

2 OF 11 CO# 40851 Dated 3-9-05 Revision: Rev 8 Dated Issued:7-29-05

60	ARC RISE SOP 0100R1	REMOVE RISERS AS DIRECTED BY SUPERVISOR.	RAW	
70	HEAT TREAT HEAT SOP 0103R5	SOLUTION ANNEAL. MAKE SURE TO BLOCK ALL FLANGES OF FORM AND RACETRACK TO MINIMIZE CREEP DISTORTION. Soak Temp: 2050F, Soak Time: 4HR + 1/2 HR/IN, Quench Type: Air Cool MAKE SURE TEST MATERIAL IS PLACED IN THE CORRECT ZONE.	DES	7/26/05
75	PHYSICAL TESTING	OBTAIN TEST SPECIMENS AND SUBMIT FOR PHYSICAL TESTING. REPORT RESULTS AS PART OF STEP 510.	JWG	
NOTE		THE ORDER OF CLEANING PROCESSES MAY BE ALTERED DUE TO CAPACITY CONSTRAINTS. HOLD POINTS AND COMPLIANCE WILL NOT BE COMPROMISED. EIO WILL BE ADVISED OF ALL CHANGES THAT MAY RESULT IN A REQUEST FOR DEVIATION FROM REQUIREMENTS.		
80	GRIND GSAW SOP 0100R3	SWING GRIND TO REMOVE RISER REMAINS AND FLASH IF REQUIRED.	8-1-05 RTG	Start Level 3
85	GRIND GCHI SOP 0100R2	CHIP AND HAD GRIND SURFACE OF PART AS REQUIRED FOR CONTOUR.	CSS 8-4-05	
90	SAND BLAST BLAS SOP 0100R6	SANDBLAST (REMOVE ALL BLAST MATERIAL FROM CASTING) SANDBLASTING WILL BE DONE USING RECYCLED SHARP ANGULAR AGGREGATE.	RTG 8-4-05	TOT 8/4/05
NOTICE	WITNESS NOTIFICATION	PROVIDE NOTICE TO EIO AND DCMA AT LEAST FIVE DAYS IN ADVANCE OF LAYOUT. EIO NOTIFIED ON <u>8/23/05</u> DCMA NOTIFIED ON <u>8/23/05</u> APPROVAL RECEIVED ON <u>NA</u>	Q ENG OR QA MGR	RTG
100	INTERIM LAYOUT SOP LAYOUT 0100	INSPECT CASTING TO VERIFY DIMENSIONS. THIS STEP MAY BE DELAYED UNTIL ALL REPAIRS ARE COMPLETE. NOTE: THE FIRST PART PRODUCED OF EACH TYPE A, B AND C WILL BE DIMENSIONED BY LAWTON PATTERN. IF DIMENSIONED BY LAWTON IT WILL BE DOCUMENTED HERE. Subsequent casting done internally per Romer Arm.	RTG	10/2/05
110	INTERIM VISUAL INSPECTION CQP-500 REV 4	VISUALLY INSPECT 100% of COMPONENT ACCORDING TO ASTM A802 LEVEL 3 IN NON MACHINED AREAS AND LEVEL 2 IN MACHINED AREAS. IF OK CHECK HERE _____ IF REJECTED CHECK HERE <input checked="" type="checkbox"/> . MARK AND REPAIR AT STEP 120.	VT - LEVEL II KLA	
NOTICE	WITNESS NOTIFICATION	PROVIDE NOTICE TO EIO AND DCMA AT LEAST FIVE DAYS IN ADVANCE OF LP STEP. EIO NOTIFIED ON <u>9/1</u> DCMA NOTIFIED ON <u>9/1</u>	Q ENG OR QA MGR	RTG

**Energy Industries of Ohio
Manufacturing and Test Sequence (MTS) Serial Number C-4**

3 OF 11 CO# 40851 Dated 3-9-05 Revision: Rev 8 Dated Issued:7-29-05

115	INTERIM 100% L.P. CQP 0300 REV 10	L.P. 100% OF COMPONENT. ACCEPTANCE PER ASTM A903. ACCEPTANCE CRITERIA- LEVEL 1 FOR HIGH STRESSED AREAS, LEVEL 2 FOR ALL OTHER AREAS. SEE LP DRAWING. IF OK CHECK HERE _____ IF REJECTED CHECK HERE <input checked="" type="checkbox"/> MARK AND REPAIR AT STEP 120.	LP - LEVEL II TRC	9-20-05	X
120	WELD SOP 0100 REV 7	EXCAVATE ANY DEFECTS FOUND DURING 100% VISUAL AND LP INSPECTION.	TRC	9-6-05	
125	GRIND GCHI SOP 0100R2	CHIP AND HAND GRIND EXCAVATION AS REQUIRED.	QA	9/6	
130	L.P. EXCAVATION CQP-300 REV 10	L.P. ALL EXCAVATIONS PRIOR TO WELDING TO ENSURE REMOVAL OF DEFECT. ACCEPTANCE PER A903. ACCEPTANCE CRITERIA-LEVEL 1 FOR HIGH STRESSED AREAS, LEVEL 2 FOR ALL OTHER AREAS. SEE LP DRAWING. IF OK CHECK HERE _____ IF REJECTED SEND BACK TO STEP 125.	LP - LEVEL II JOK	9-8-05	Interim LP
165	SAND BLAST BLAS SOP 0100R6	SANDBLAST (REMOVE ALL BLAST MATERIAL FROM CASTING) SANDBLASTING WILL BE DONE USING RECYCLED SHARP ANGULAR AGGREGATE.	BSD	9-7-05	
170	WELD MAP	MAP ALL MAJOR WELDS WITH DIGITAL PHOTO/MAPS INDICATING LOCATION. SERIALIZE DEFECTS ON CASTING, USE SCALE IN PHOTOS AND DOCUMENT SIZE. THIS IS TO BE PERFORMED BY SUPERVISOR, INSPECTION LEAD MAN OR THEIR DESIGNEE, FILE WITH QA. USE YELLOW MARKER. MUST INDICATE ON MAP ALL MAJOR WELDS, DEFINED AS GREATER THAN 20% OF THE WALL OR 1 INCH WHICHEVER IS LESS OR 10 SQUARE INCHES APPROXIMATLY 3.3"X3.3".	JRS	9-12	
NOTICE	WITNESS NOTIFICATION	PROVIDE NOTICE TO EIO AND DCMA AT LEAST FIVE DAYS IN ADVANCE OF X-RAY AND DIMENSIONAL STEPS. EIO NOTIFIED ON <u>8/1</u> DCMA NOTIFIED ON <u>8/4</u>	Q ENG OR QA MGR	RMS	
190	X-RAY AT MQS MQS PROCEDURE 20.H.010 REV 0	X-RAY PER TECHNIQUE # 12726 USE CALIBRATED DENSITOMETER FOR DENSITY VERIFICATION. WHEN MARKING USE BLACK MARKERS. ATTACH TECHNIQUE, READER SHEET FOR ALL RADIOGRAPHS. MUST INDICATE RADIOGRAPHER AND ASNT CERTIFICATION LEVEL ON READER SHEET.	RT - LEVEL II MQS	8-13-05	
210	X-RAY CQP 401 REV 5	X-RAY INTERPRETATION. ACCEPTANCE MSS SP 54. ATTACH TECHNIQUE, READER SHEET FOR ALL RADIOGRAPHS. MUST INDICATE RADIOGRAPHER AND ASNT CERTIFICATION LEVEL ON READER SHEET. IF OK CHECK HERE _____ AND SEND TO STEP 260. REJECTED CHECK HERE <input checked="" type="checkbox"/> MARK UP DEFECTS AND SEND THE CASTING TO STEP 220.	RT - LEVEL II RBIK	8-19-05	

**Energy Industries of Ohio
Manufacturing and Test Sequence (MTS) Serial Number C-4**

4 OF 11 CO# 40851 Dated 3-9-05 Revision: Rev 8 Dated Issued:7-29-05

220	WELD SOP 0100 REV 7	EXCAVATE ANY DEFECTS FOUND DURING RADIOGRAPHY.		
225	GRIND GCHI SOP 0100R2	CHIP AND HAND GRIND EXCAVATION AS REQUIRED.		
230	L.P. EXCAVATION CQP-300 REV 10	L.P. ALL EXCAVATIONS PRIOR TO WELDING TO ENSURE REMOVAL OF DEFECT. ACCEPTANCE PER A903. ACCEPTANCE CRITERIA-LEVEL 1 FOR HIGH STRESSED AREAS, LEVEL 2 FOR ALL OTHER AREAS. SEE LP DRAWING. IF OK CHECK HERE <input checked="" type="checkbox"/> IF REJECTED SEND BACK TO STEP 225.	LP - LEVEL II JOK 8/27/05	9/8/05
240	WELD MAP	MAP ALL WELDS WITH DIGITAL PHOTO/MAPS INDICATING LOCATION. SERIALIZE DEFECTS ON CASTING, USE SCALE IN PHOTOS AND DOCUMENT SIZE. THIS IS TO BE PERFORMED BY SUPERVISOR, INSPECTION LEAD MAN OR THEIR DESIGNEE, FILE WITH QA. USE YELLOW MARKER. MUST INDICATE ON MAP ALL MAJOR WELDS, DEFINED AS GREATER THAN 20% OF THE WALL OR 1 INCH WHICHEVER IS LESS OR 10 SQUARE INCHES APPROXIMATLY 3.3"X3.3".	JB	
NOTICE	WITNESS NOTIFICATION	PROVIDE NOTICE TO EIO AND DCMA AT LEAST FIVE DAYS IN ADVANCE OF WELD STEP. EIO NOTIFIED ON 8/23/05 DCMA NOTIFIED ON 8/23/05	Q ENG OR QA MGR	KNT
260	QA APPROVAL HOLD POINT	QA TO APPROVE ELECTRODE PRIOR TO USE PROCEDURE USED: 15-SMAW-CF8MNMN ^{MOD} MATERIAL/LOT USED: 3018926-78309 QUALITY ENG. Name: <u>LMA</u> Date: 9/14/05		2080 S. P. 9/14/05
270	WELD SOP 0100 REV 7	WELD REPAIR DEFECTS AS MARKED. FOR WELDS <2" - WPS 10-SMAW-CF8MNMN MOD REV 1(Flat) or 25 SMAW-CF8MNMN MOD REV 0 (Vertical) LOT # 3018926-78309 W019711 S01786582 FOR WELDS <8" - WPS 15-GMAW-CF8MNMN MOD REV 2 3018515/ 78308	OK 92905 TD 9/28	
280	GRIND GCHI SOP 0100R2	HAND GRIND WELDS.	QB MG 9/30	
290	L.P. WELD CQP 0300 REV 10	L.P. WELD REPAIRS ACCEPTANCE PER ASTM A903. ACCEPTANCE CRITERIA-LEVEL 1 FOR HIGH STRESSED AREAS, LEVEL 2 FOR ALL OTHER AREAS. SEE LP DRAWING. IF OK CHECK HERE <input type="checkbox"/> WASH AND SEND TO STEP 300. IF REJECTED CHECK HERE <input checked="" type="checkbox"/>	LP - LEVEL II JPS 9/30	10/3/05
	REPEAT	REPEAT STEPS 220 TO 290 AS REQUIRED TILL CLEAR THROUGH VISUAL INSPECTION & PENETRANT INSPECTION. DOCUMENT REWORK ON STEPS S220 TO S290. IF OK CHECK HERE <input type="checkbox"/> AND PROCEED TO STEP 295.		
	REPEAT STEPS	SUPPLEMENTAL REPAIR STEPS		
S220	WELD SOP 0100 REV 7	EXCAVATE ANY DEFECTS FOUND DURING RADIOGRAPHY.		

1ST RBK 10/14
2ND DW
3RD RBK
4TH
5TH

3RD RBK
DW
10-27-05

RT OK 10/2

2080
S. P. 9/14/05

2080
S. P. 10/3/05

2080
S. P. 10/27/05

**Energy Industries of Ohio
Manufacturing and Test Sequence (MTS) Serial Number C-4**

5 OF 11 CO# 40851 Dated 3-9-05 Revision: Rev 8 Dated Issued: 7-29-05

S230	L.P. EXCAVATION CQP-300 REV 10	L.P. ALL EXCAVATIONS PRIOR TO WELDING TO ENSURE REMOVAL OF DEFECT. ACCEPTANCE PER A903. ACCEPTANCE CRITERIA-LEVEL 1 FOR HIGH STRESSED AREAS, LEVEL 2 FOR ALL OTHER AREAS. SEE LP DRAWING.	LP - LEVEL II				
S240	WELD MAP	MAP ALL MAJOR WELDS WITH DIGITAL PHOTO/MAPS INDICATING LOCATION. SERIALIZE DEFECTS ON CASTING, USE SCALE IN PHOTOS AND DOCUMENT SIZE. THIS IS TO BE PERFORMED BY SUPERVISOR, INSPECTION LEAD MAN OR THEIR DESIGNEE, FILE WITH QA. USE YELLOW MARKER. MUST INDICATE ON MAP ALL MAJOR WELDS, DEFINED AS GREATER THAN 20% OF THE WALL OR 1 INCH WHICHEVER IS LESS OR 10 SQUARE INCHES APPROXIMATELY 3.3"X3.3".					
NOTICE	WITNESS NOTIFICATION	PROVIDE NOTICE TO EIO AND DCMA AT LEAST FIVE DAYS IN ADVANCE OF WELD STEP. EIO NOTIFIED ON _____ DCMA NOTIFIED ON _____	Q ENG OR QA MGR				
S260	QA APPROVAL HOLD POINT	QA TO APPROVE ELECTRODE PRIOR TO USE. PROCEDURE USED: <u>GMAW</u> MATERIAL /LOT USED: <u>3018513-78308</u> QUALITY ENG. Name: <u>RMS</u> Date: _____					
S270	WELD SOP 0100 REV 7	WELD REPAIR DEFECTS AS MARKED. FOR WELDS <2" - WPS 10-SMAW-CF8MNMN MOD REV 1 (Flat) or 25 SMAW-CF8MNMN MOD REV 0 (Vertical) FOR WELDS <8" - WPS 15-GMAW-CF8MNMN MOD REV 2	TAD 10/28				
S280	GRIND GCHI SOP 0100R2	HAND GRIND WELDS.	KLB 10/28				
S290	L.P. WELD CQP 0300 REV 10	L.P. WELD REPAIRS ACCEPTANCE PER ASTM A903. ACCEPTANCE CRITERIA-LEVEL 1 FOR HIGH STRESSED AREAS, LEVEL 2 FOR ALL OTHER AREAS. SEE LP DRAWING. IF OK CHECK HERE _____ WASH AND SEND TO STEP 300. IF REJECTED CHECK HERE _____ AND RETURN TO STEP S220.	LP - LEVEL II	OK	OK	OK	OK
	REPEAT	REPEAT STEPS S220 TO S290 AS REQUIRED TILL CLEAR THROUGH VISUAL INSPECTION & PENETRANT INSPECTION.	QA ENG.	REJ	REJ	REJ	REJ
295	TEST MAG PERM SOP MAG PERM 100, REV 1	TEST MAG PERMEABILITY REPAIR AREAS TEST AT LEAST 5 POINTS PER WELD. ACCEPTANCE 1.02. IF OK CHECK HERE <input checked="" type="checkbox"/> AND GO TO STEP 300. IF REJECTED CHECK HERE _____				CA	10/28
296	GRIND GCHI SOP 0100R2	GRIND AREAS OF NON COMPLIANCE AND RETURN TO STEP 295. REPEAT UNTIL COMPLIANCE IS ACHIEVED.				NA	
300	X-RAY (NOTE)	IF RADIO GRAPHED AREAS ARE GREATER THAN FOUR TO FIVE INCHES THE CASTING WILL BE SENT TO MQS. SEND TO MQS CHECK HERE _____ RADIOGRAPH AT CAF CHECK HERE <input checked="" type="checkbox"/>	QA ENGINE ER				RMS

**Energy Industries of Ohio
Manufacturing and Test Sequence (MTS) Serial Number C-4**

6 OF 11 CO# 40851 Dated 3-9-05 Revision: Rev 8 Dated Issued:7-29-05

NA

310 A	MQS X-RAY DEFECTS REPAIRED BY WELDING	X-RAY PER TECHNIQUE # 12726 USE CALIBRATED DENSITOMETER FOR DENSITY VERIFICATION. ATTACH TECHNIQUE, READER SHEET FOR ALL RADIOGRAPHS. MUST INDICATE RADIOGRAPHER AND ASNT CERTIFICATION LEVEL ON READER SHEET.	LEVEL II					
310 B	CAF X-RAY DEFECTS REPAIRED BY WELDING CQP 401 REV 5	X-RAY PER TECHNIQUE # 12726 USE CALIBRATED DENSITOMETER FOR DENSITY VERIFICATION. ATTACH TECHNIQUE, READER SHEET FOR ALL RADIOGRAPHS. MUST INDICATE RADIOGRAPHER AND ASNT CERTIFICATION LEVEL ON READER SHEET.	RT - LEVEL II					
320	X-RAY CQP 401 REV 5	X-RAY INTERPRETATION. ACCEPTANCE MSS SP 54. ATTACH TECHNIQUE, READER SHEET FOR ALL RADIOGRAPHS. MUST INDICATE RADIOGRAPHER AND ASNT CERTIFICATION LEVEL ON READER SHEET. IF OK CHECK HERE _____ AND SEND TO STEP 340. REJECTED CHECK HERE _____ MARK UP DEFECTS AND SEND THE CASTING TO STEP 220.	RT - LEVEL II	<i>all accepted 10/23/05</i>				
	REPEAT STEPS	SUPPLEMENTAL REPAIR STEPS		1 ST	2 ND	3 RD	4 TH	5 TH
S321	WELD SOP 0100 REV 7	EXCAVATE ANY DEFECTS FOUND DURING RADIOGRAPHY.						
S322	L.P. EXCAVATION CQP-300 REV 10	L.P. ALL EXCAVATIONS PRIOR TO WELDING TO ENSURE REMOVAL OF DEFECT. ACCEPTANCE PER A903. ACCEPTANCE CRITERIA-LEVEL 1 FOR HIGH STRESSED AREAS, LEVEL 2 FOR ALL OTHER AREAS. SEE LP DRAWING.	LP - LEVEL II					
S323	WELD MAP	MAP ALL MAJOR WELDS WITH DIGITAL PHOTO/MAPS INDICATING LOCATION. SERIALIZE DEFECTS ON CASTING, USE SCALE IN PHOTOS AND DOCUMENT SIZE. THIS IS TO BE PERFORMED BY SUPERVISOR, INSPECTION LEAD MAN OR THEIR DESIGNEE, FILE WITH QA. USE YELLOW MARKER. MUST INDICATE ON MAP ALL MAJOR WELDS, DEFINED AS GREATER THAN 20% OF THE WALL OR 1 INCH WHICHEVER IS LESS OR 10 SQUARE INCHES APPROXIMATLY 3.3"X3.3".						
NOTICE	WITNESS NOTIFICATION	PROVIDE NOTICE TO EIO AND DCMA AT LEAST FIVE DAYS IN ADVANCE OF WELD STEP. EIO NOTIFIED ON _____ DCMA NOTIFIED ON _____	Q ENG OR QA MGR					
S324	QA APPROVAL HOLD POINT	QA TO APPROVE ELECTRODE PRIOR TO USE. PROCEDURE USED: _____ MATERIAL /LOT USED : _____ QUALITY ENG. Name: _____ Date: _____						
S325	WELD SOP 0100 REV 7	WELD REPAIR DEFECTS AS MARKED. FOR WELDS <2" - WPS 10-SMAW-CF8MNMN MOD REV 1(Flat) or 25 SMAW-						

**Energy Industries of Ohio
Manufacturing and Test Sequence (MTS) Serial Number C-4**

7 OF 11 CO# 40851 Dated 3-9-05 Revision: Rev 8 Dated Issued:7-29-05

NA

		CF8MNMN MOD REV 0 (Vertical) FOR WELDS <8" - WPS 15-GMAW-CF8MNMN MOD REV 2					
S326	GRIND GCHI SOP 0100R2	HAND GRIND WELDS.					
S327	L.P. WELD CQP 0300 REV 10	L.P. WELD REPAIRS ACCEPTANCE PER ASTM A903. ACCEPTANCE CRITERIA-LEVEL 1 FOR HIGH STRESSED AREAS, LEVEL 2 FOR ALL OTHER AREAS. SEE LP DRAWING. IF OK CHECK HERE _____ WASH AND SEND TO STEP 300. IF REJECTED CHECK HERE _____ AND RETURN TO STEP S321.	LP - LEVEL II	OK REJ	OK REJ	OK REJ	OK REJ
	REPEAT	REPEAT STEPS S321 TO S327 AS REQUIRED TILL CLEAR THROUGH VISUAL INSPECTION & PENETRANT INSPECTION.	QA ENG.				
340	SAND BLAST BLAS SOP 0100R6	SANDBLAST (REMOVE ALL BLAST MATERIAL FROM CASTING) SANDBLASTING WILL BE DONE USING RECYCLED SHARP ANGULAR AGGREGATE.			<i>CA</i>		<i>10/31</i>
NOTICE	WITNESS NOTIFICATION	PROVIDE NOTICE TO EIO AND DCMA AT LEAST FIVE DAYS IN ADVANCE OF VISUAL AND LP STEPS. EIO NOTIFIED ON <u><i>10/24</i></u> DCMA NOTIFIED ON <u><i>10/24</i></u>			Q ENG OR QA MGR		<i>RMS</i>
350	FINAL VISUAL INSPECTION CQP-500 REV 4	VISUALLY INSPECT 100% of COMPONENT ACCORDING TO ASTM A802 LEVEL 3 IN NON MACHINED AREAS AND LEVEL 2 IN MACHINED AREAS. IF OK CHECK HERE <input checked="" type="checkbox"/> IF REJECTED CHECK HERE _____ . MARK AND REPAIR AT STEP 385. MUST BE PERFORMED BY LEVEL II in VT.			VT - LEVEL II <i>KRA</i> <i>10-31-05</i>		
360	FINAL L.P. CQP 0300 REV 10	FINAL L.P. 100% OF COMPONENT. ACCEPTANCE PER ASTM A903. ACCEPTANCE CRITERIA-LEVEL 1 FOR HIGH STRESSED AREAS, LEVEL 2 FOR ALL OTHER AREAS. SEE LP DRAWING. IF OK CHECK HERE _____ WASH AND SEND TO STEP 455. IF REJECTED CHECK HERE <input checked="" type="checkbox"/>			LP - LEVEL II <i>JR</i> <i>10/31</i>		
380	WELD SOP 0100 REV 7	EXCAVATE ANY DEFECTS FOUND DURING FINAL PENETRANT INSPECTION.			<i>RG</i> <i>10/30</i>		
385	GRIND GCHI SOP 0100R2	CHIP AND HAD GRIND EXCAVATION AS REQUIRED.			<i>Grandonby</i>		
390	L.P. EXCAVATION CQP-300 REV 10	L.P. ALL EXCAVATIONS PRIOR TO WELDING TO ENSURE REMOVAL OF DEFECT. ACCEPTANCE PER A903. IF OK CHECK HERE _____ IF REJECTED SEND BACK TO STEP 385.			LP - LEVEL II <i>no welds.</i>		

**Energy Industries of Ohio
Manufacturing and Test Sequence (MTS) Serial Number C-4**

8 OF 11 CO# 40851 Dated 3-9-05 Revision: Rev 8 Dated Issued:7-29-05

400	WELD MAP	MAP ALL MAJOR WELDS WITH DIGITAL PHOTO/MAPS INDICATING LOCATION. SERIALIZE DEFECTS ON CASTING, USE SCALE IN PHOTOS AND DOCUMENT SIZE. THIS IS TO BE PERFORMED BY SUPERVISOR, INSPECTION LEAD MAN OR THEIR DESIGNEE, FILE WITH QA. USE YELLOW MARKER. MUST INDICATE ON MAP ALL MAJOR WELDS, DEFINED AS GREATER THAN 20% OF THE WALL OR 1 INCH WHICHEVER IS LESS OR 10 SQUARE INCHES APPROXIMATLY 3.3"X3.3".	NA	
420	QA APPROVAL HOLD POINT	QA TO APPROVE ELECTRODE PRIOR TO USE. PROCEDURE USED: _____ MATERIAL/LOT USED: _____ QUALITY ENG. Name: _____ Date: _____		
430	WELD SOP 0100 REV 7	WELD REPAIR DEFECTS AS MARKED. FOR WELDS <2" - WPS 10-SMAW-CF8MNMN MOD REV 1(Flat) or 25 SMAW-CF8MNMN MOD REV 0 (Vertical) FOR WELDS <8" - WPS 15-GMAW-CF8MNMN MOD REV 2		
440	GRIND GCHI SOP 0100 REV 2	HAND GRIND WELDS.		
450	L.P. WELDS CQP 0300 REV 10	L.P. WELD REPAIRS ACCEPTANCE PER ASTM A903. IF OK CHECK HERE _____ WASH AND SEND TO STEP 460. IF REJECTED CHECK HERE _____ AND RETURN TO STEP 440.	LP - LEVEL II	
	REPEAT	REPEAT STEPS 350 TO 450 AS REQUIRED TILL WELDS CLEAR FINAL LIQUID PENETRANT INSPECTION. DOCUMENT REWORK ON A SUPPLEMENTAL MTS	QA ENG. <i>Ch</i>	10/31
451	TEST MAG PERM SOP MAG PERM 100, REV 1	TEST MAG PERMEABILITY REPAIR AREAS. RECORD ON WELD MAP LIST. TEST AT LEAST 5 POINTS PER WELD. ACCEPTANCE 1.02. IF OK CHECK HERE <input checked="" type="checkbox"/> AND GO TO STEP 430. IF REJECTED CHECK HERE _____	KDA	10/31
452	GRIND GCHI SOP 0100R2	GRIND AREAS OF NON COMPLIANCE AND RETURN TO STEP 451. REPEAT UNTIL COMPLIANCE IS ACHIEVED.	NA	
455	HEAT TREAT	STRESS RELIEF. Load casting into cold furnace. Ramp up to 1100 F at rate of 200 F per hour. Hold at temp 4 hours. Furnace cool to 500 F at 50 F per hour. Air cool. Submit furnace charts to QA.		
NOTICE	WITNESS NOTIFICATION	PROVIDE NOTICE TO EIO AND DCMA AT LEAST FIVE DAYS IN ADVANCE OF VISUAL AND LP STEPS. EIO NOTIFIED ON <u>10/24</u> DCMA NOTIFIED ON <u>10/24</u>	Q ENG OR QA MGR	

**Energy Industries of Ohio
Manufacturing and Test Sequence (MTS) Serial Number C-4**

9 OF 11 CO# 40851 Dated 3-9-05 Revision: Rev 8 Dated Issued:7-29-05

460	FINAL VISUAL INSPECTION CQP-500 REV 4	VISUALLY INSPECT 100% of COMPONENT ACCORDING TO ASTM A802 LEVEL 3 ALL CONDITIONS. IF OK CHECK HERE _____ IF REJECTED CHECK HERE _____ . MARK AND REPAIR AT STEP 390. MUST BE PERFORMED BY LEVEL II in VT.	VT - LEVEL II KLA	10/31
470	FINAL L.P. CQP 0300 REV 10	FINAL L.P. 100% OF COMPONENT. ACCEPTANCE PER ASTM A903. ACCEPTANCE CRITERIA-LEVEL 1 FOR HIGH STRESSED AREAS, LEVEL 2 FOR ALL OTHER AREAS. SEE LP DRAWING. IF OK CHECK HERE <input checked="" type="checkbox"/> WASH AND SEND TO STEP 455. IF REJECTED CHECK HERE _____ . DOCUMENT REPAIRS USING S321 THROUGH S327.	LP - LEVEL II 10/31	ADK
NOTICE	WITNESS NOTIFICATION	PROVIDE NOTICE TO EIO AND DCMA AT LEAST FIVE DAYS IN ADVANCE OF MAG PERM STEPS. EIO NOTIFIED ON <u>10/24</u> DCMA NOTIFIED ON <u>10/24</u>	Q ENG OR QA MGR	RMS
500	FINAL MAG PERM INSPECTION SOP MAG PERM 100, REV 1	PERFORM MAG PERM TESTING WITH SEVRIN GAUGE. ACCEPTANCE 1.02. CHECK THE ENTIRE SURFACE ON A 6"BY6" GRID. REPORT RESULTS. USE A 6" SQUARE BLOCK TO INDICATE TEST LOCATIONS AND RECORD RESULTS. COMPLIANT AREAS WILL NOT BE MARKED. MARK NONCOMPLIANT AREAS WITH AN "X" FOR REPAIR. OK CHECK HERE <input checked="" type="checkbox"/> AND GO TO STEP 530. IF REJECTED CHECK HERE _____	KLA	10/31
510	GRIND GCHI SOP 0100 REV 2	HAND GRIND WITH SUITABLE CONE OR OTHER SIMILAR GRINDER AS REQUIRED TO ENSURE REMOVAL OF MATERIAL TO ACHIEVE MAG PERM REQUIREMENT. CIRCLE AREA REMEDIATE FOR RETEST.	MA	
520	RETEST MAG PERM SOP MAG PERM 100, REV 1	RETEST MAG PERMEABILITY AT FAILED TEST POINTS. MARK NONCOMPLIANT AREAS WITH AN "X" FOR REPAIR. ACCEPTANCE 1.02. IF OK CHECK HERE _____ . IF REJECTED CHECK HERE _____ RETURN TO STEP 510.	↓ ✓	
530	DOC. REVIEW	REVIEW DOCUMENTS AS REQUIRED IN CAF CHECKLIST, ALL DOCUMENTS NOTED TO BE ACCESSIBLE FOR AUDITING. (SHIPPER, C OF C, M.T.R., M.T.S., INSPECTION REPORT, X-RAY READER SHEETS AND HEAT TREAT CHARTS)	CAK	10/31
NOTICE	RELEASE FROM EIO	PROVIDE DOCUMENTS TO EIO. SENT ON <u>10/27 + 10/28</u> BY <u>CAK</u> . RECEIVED RELEASE FROM EIO ON <u>Date 10/31</u>	Q ENG OR QA MGR	CAK
540	PACK AND SHIP	PACKAGE AND SHIP TO MAJOR TOOL.		
1000	REVISION HISTORY	ORIGINAL 12-14-04. Approved 12-14-04. Revision level 1- Revised 1-26-05 new page 8, correct High stress areas, Revision level 2 3-16-05, delete LO step 455. Revision 3 3-28-05 Added note regarding hold point at weld step 400. Revision level 4 written for C-2 casting 4-18-05. Rev 5 added Layout SOP# and note regarding first casting layout responsibility. 5-10-05. Rev 6 added word LOT to weld material steps. 5-29-05. Rev 7 6-14-05 added "LOT" to weld step on supplement page. Rev. 8 7-29-05 added stress relief , deleted weld hold points, added vertical weld procedure, and several editorial changes.	CARUUD	

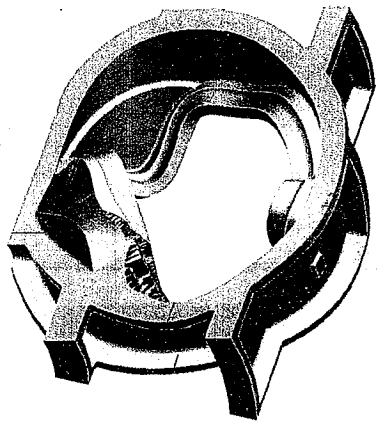

GENERAL ISOMETRIC
VIEW FROM TOP SIDE

**TABS DESIGNATE
CRITICAL AREA**

RED AREA INDICATES HIGH STRESSED AREA

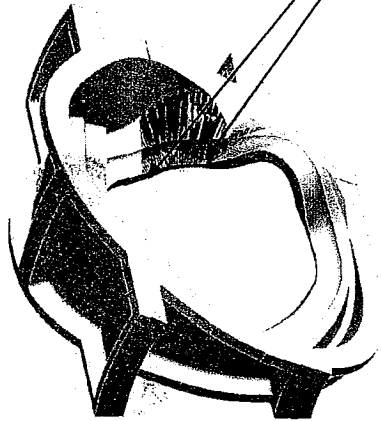

TOP SIDE ISOMETRIC

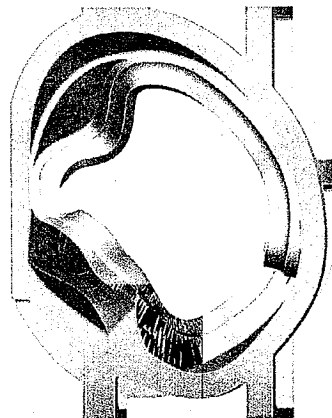

TOP SIDE VIEW

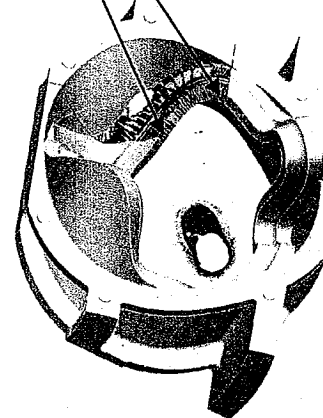

BOTTOM SIDE ISOMETRIC

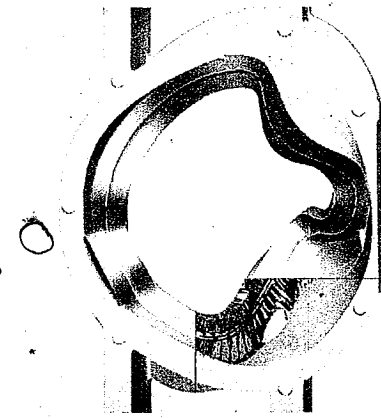

BOTTOM SIDE VIEW

**Energy Industries of Ohio
Manufacturing and Test Sequence (MTS) Serial Number C-4**

11 OF 11

CO# 40851 Dated 3-9-05 Revision: Rev 8

Dated Issued:7-29-05

Energy Industries of Ohio

FIVE PARTS KEEP TOGETHER

Manufacturing and Test Sequence (MTS) Coill C Shim

CO# 40851, Pattern SE (141-073 -3) MS73220-2 Dated December 14, 2004 Revision:Original

Page 1 of 6

Dated Issued:4-27-05

OPER. #	STATION	DESCRIPTION OF PROCESS	Name	Date
		Keep all parts together. Sign and date each step when all 5 parts have been completed.		
10	QUALITY RELEASE	REVIEW AND APPROVE MTS. RECEIVED APPROVAL FROM EIO ON <u>Date</u> FROM <u>12/15/04</u> SIGNED QUALITY MANAGER	<u>CTR</u>	<u>4/21/05</u>
20	PATTERN NPAT SOP 0100REV2	APPLY APPROPRIATE PART NUMBER, SERIAL NUMBER, FOUNDRY MARK, TO THE PATTERN.	<u>TB</u>	<u>4/22/05</u>
30	MOLD MOLD SOP 0400 REV 8 CALIBRATION PER MOLD SOP 0900 REV 5 PREPARATION PER MOLD SOP 1100R2/1200R2/1300R1 SAND TESTING PER MOLD SOP 1400R2/1500R3/1600R2	MOLD PER WORK INSTRUCTIONS IN MAPICS ROUTING AND SOPS REFERENCED. ENGINEER OF RECORD - ROGER BROMAN, CONSULT ON MOLD-RELATED CONCERNS. MOLD MATERIALS REQUIRED PER MAPICS BOM. NOTIFY ENGINEER OF ANY SUBSTITUTIONS.	<u>CR</u>	<u>4/22/05</u>
40	POUR MELT SOP 0100R5 MELT SOP 0700R2 MELT SOP 0600R2	METAL MUST BE AOD REFINED OR AOD INGOT. VIRGIN METAL ADDITIONS ALLOWED. RECORD POURING TEMPERATURE: <u>2825</u> CASTING POURED AT: <u>12:45 Am</u> DATE: <u>4/20</u> HEAT #'s: <u>22A 29198</u> ELAPSED POUR TIME <u>NA</u> KEEL BLOCKS POURED: <u>yes</u> Sample from ladle to be analyzed for final chemical analysis and reported on material certifications. Sample Taken by: <u>SR</u> Analyzed: <u>G Hunt</u> Date: <u>4/20</u> Note: Make 15 additional test bars for mechanical testing.	<u>JG</u>	<u>4/20/05</u>
50	MELT SOP 0800R2	SHAKEOUT	<u>CA</u>	<u>4/29</u>
60	ARC RISE SOP 0100R1	REMOVE RISERS AS DIRECTED BY SUPERVISOR.	<u>BNVH</u>	<u>6/16/05</u>
70	HEAT TREAT HEAT SOP 0103R5	SOLUTION ANNEAL. With C-1 Coil.	<u>DLS</u>	<u>6/2/05</u>

Energy Industries of Ohio

Manufacturing and Test Sequence (MTS) Coill C Shim

FIVE PARTS KEEP TOGETHER

CO# 40851, Pattern SE 141-073 -3 MS73220-2 Dated December 14, 2004 Revision:Original

Page 2 of 6

Dated Issued:4-27-05

80	PHYSICAL TESTING	OBTAIN TEST SPECIMENS AND SUBMIT FOR PHYSICAL TESTING. REPORT RESULTS AS PART OF STEP 480.			4/29
90	GRIND GSPA SOP 0100R3 GCHI SOP 0100R2	SWING GRIND TO REMOVE RISER REMAINS AND FLASH IF REQUIRED. CHIP AND HAD GRIND SURFACE OF PART AS REQUIRED.			CEG 6/16/05
100	SAND BLAST BLAS SOP 0100R6	SANDBLAST (REMOVE ALL BLAST MATERIAL FROM CASTING) SANDBLASTING WILL BE DONE USING RECYCLED SHARP ANGULAR AGGREGATE.			MTW 6/16/05
110	VISUAL INSPECTION CQP-500 REV 4	VISUALLY INSPECT 100% of COMPONENT ACCORDING TO ASTM A802 LEVEL 3 ALL CONDITIONS. IF OK CHECK HERE <input checked="" type="checkbox"/> . IF REJECTED CHECK HERE ____ . MARK AND REPAIR AT STEP 130.	VT - LEVEL II		SSB 6-16-05
NOTICE	WITNESS NOTIFICATION	PROVIDE NOTICE TO EIO AND DCMA AT LEAST FIVE DAYS IN ADVANCE OF LP STEP. EIO NOTIFIED ON <u>6/13</u> DCMA NOTIFIED ON <u>4/13</u>	Q ENG OR QA MGR		CAR 6-16-05
120	100% L.P. CQP 0300 REV 10	L.P. 100% OF COMPONENT. ACCEPTANCE PER ASTM A903. ACCEPTANCE CRITERIA- LEVEL 2. IF OK CHECK HERE <input checked="" type="checkbox"/> . IF REJECTED CHECK HERE ____ <input checked="" type="checkbox"/> MARK AND REPAIR AT STEP <u>120</u> .	LP - LEVEL II		SSB 6-16-05
130	WELD SOP 0100 REV 7	EXCAVATE ANY DEFECTS FOUND DURING 100% VISUAL AND LP INSPECTION.			W/P 6-16-05
140	L.P. EXCAVATION CQP-300 REV 10	L.P. ALL EXCAVATIONS PRIOR TO WELDING TO ENSURE REMOVAL OF DEFECT. ACCEPTANCE PER A903. ACCEPTANCE CRITERIA- LEVEL 2.	LP - LEVEL II		
150	SAND BLAST BLAS SOP 0100R6	SANDBLAST (REMOVE ALL BLAST MATERIAL FROM CASTING) SANDBLASTING WILL BE DONE USING RECYCLED SHARP ANGULAR AGGREGATE.			
160	WELD MAP	MAP ALL WELDS WITH DIGITAL PHOTO/MAPS. SERIALIZE DEFECTS ON CASTING, USE SCALE IN PHOTOS AND DOCUMENT SIZE. THIS IS TO BE PERFORMED BY SUPERVISOR, INSPECTION LEAD MAN OR THEIR DESIGNEE, FILE WITH QA.. USE YELLOW MARKER. MUST SEND REPORT ON ALL WELDS OVER 10% OF NOMINAL WALL THICKNESS TO CUSTOMER. DEFECTS>10% YES _____, REPORT SENT BY _____ DATE _____ DEFECTS < 10 % _____ SIGN BY QA ENG.			
NOTICE	WITNESS NOTIFICATION	PROVIDE NOTICE TO EIO AND DCMA AT LEAST FIVE DAYS IN ADVANCE OF XRAY AND LAYOUT STEPS. EIO NOTIFIED ON <u>6/13</u> DCMA NOTIFIED ON <u>6/13</u>	Q ENG OR QA MGR		RMS

Energy Industries of Ohio

FIVE PARTS KEEP TOGETHER

Manufacturing and Test Sequence (MTS) Coill C Shim

CO# 40851, Pattern SE 141-073 -3 MS73220-2 Dated December 14, 2004 Revision:Original

Page 3 of 6

Dated Issued:4-27-05

170	CAF X-RAY CQP 401 REV 5	X-RAY PER TECHNIQUE: To be determined. USE CALIBRATED DENSITOMETER FOR DENSITY VERIFICATION. ATTACH TECHNIQUE, READER SHEET FOR ALL RADIOGRAPHS. MUST INDICATE RADIOGRAPHER AND ASNT CERTIFICATION LEVEL ON READER SHEET.	RT - LEVEL II OK D	DWM 6-28-05
180	X-RAY CQP 401 REV 5	X-RAY INTERPRETATION. ACCEPTANCE MSS SP 54. ATTACH TECHNIQUE, READER SHEET FOR ALL RADIOGRAPHS. MUST INDICATE RADIOGRAPHER AND ASNT CERTIFICATION LEVEL ON READER SHEET. IF OK CHECK HERE <input checked="" type="checkbox"/> AND SEND TO STEP 310. REJECTED CHECK HERE <input type="checkbox"/> MARK UP DEFECTS AND SEND THE CASTING TO STEP 200.	RT - LEVEL II	DWM 6-28-05
190	LAYOUT	INSPECT CASTING TO VERIFY DIMENSIONS. THIS MAY BE PERFORMED BEFORE OR AFTER STEP 180. DIMENSIONED <u>JAS</u> DATE <u>10/28/05</u> RELEASED _____ (ENGINEER ONLY)	JAS	10/28/05
200	WELD SOP 0100 REV 7	EXCAVATE ANY DEFECTS FOUND DURING RADIOGRAPHY.	NA	
210	L.P. EXCAVATION CQP-300 REV 10	L.P. ALL EXCAVATIONS PRIOR TO WELDING TO ENSURE REMOVAL OF DEFECT. ACCEPTANCE PER A903. ACCEPTANCE CRITERIA- LEVEL 2.	LP - LEVEL II	
220	WELD MAP	MAP ALL WELDS WITH DIGITAL PHOTO/MAPS. SERIALIZE DEFECTS ON CASTING, USE SCALE IN PHOTOS AND DOCUMENT SIZE. THIS IS TO BE PERFORMED BY SUPERVISOR, INSPECTION LEAD MAN OR THEIR DESIGNEE, FILE WITH QA.. MUST SEND REPORT ON ALL WELDS OVER 10% OF NOMINAL WALL THICKNESS TO CUSTOMER. DEFECTS>10% YES _____, REPORT SENT BY _____ DATE _____ DEFECTS < 10 % _____ SIGN BY QA ENG.		
NOTICE	WITNESS NOTIFICATION	PROVIDE NOTICE TO EIO AND DCMA AT LEAST FIVE DAYS IN ADVANCE OF WELD STEP. EIO NOTIFIED ON _____ DCMA NOTIFIED ON _____	Q ENG OR QA MGR	
230	QA APPROVAL HOLD POINT	QA TO APPROVE ELECTRODE PRIOR TO USE. PROCEDURE USED: _____ MATERIAL USED: _____ QUALITY ENG. Name: _____ Date: _____		
240	WELD SOP 0100 REV 7	WELD REPAIR DEFECTS AS MARKED. FOR WELDS <2" - WPS 10-SMAW-CF8MNMN MOD REV 1 FOR WELDS <8" - WPS 15-GMAW-CF8MNMN MOD REV 2		
250	GRIND GCHI SOP 0100R2	HAND GRIND WELDS.		

Energy Industries of Ohio

FIVE PARTS KEEP TOGETHER

Manufacturing and Test Sequence (MTS) Coill C Shim

CO# 40851, Pattern SE 141-073 -3 MS73220-2 Dated December 14, 2004 Revision: Original

Page 4 of 6

CA
Dated Issued: 4-27-05

260	L.P. WELD CQP 0300 REV 10	L.P. WELD REPAIRS ACCEPTANCE PER ASTM A903. ACCEPTANCE CRITERIA-LEVEL 2. IF OK CHECK HERE _____ WASH AND SEND TO STEP 300. IF REJECTED CHECK HERE _____ AND RETURN TO STEP 220.	LP - LEVEL II	
	REPEAT	REPEAT STEPS __220 TO 260__ AS REQUIRED TILL CLEAR THROUGH VISUAL INSPECTION & PENETRANT INSPECTION. DOCUMENT REWORK ON A SUPPLEMENTAL MTS	QA ENG.	
270	TEST MAG PERM SOP MAG PERM 100, REV 1	TEST MAG PERMEABILITY REPAIR AREAS RECORD ON WELD MAP LIST. TEST AT LEAST 5 POINTS PER WELD. ACCEPTANCE 1.02. IF OK CHECK HERE _____ AND GO TO STEP 290. IF REJECTED CHECK HERE _____.		
280	GRIND GCHI SOP 0100R2	GRIND AREAS OF NON COMPLIANCE AND RETURN TO STEP 270. REPEAT UNTILL COMPLIANCE IS ACHIEVED.	<i>CA</i>	<i>10/30</i>
290	CAF X-RAY DEFECTS REPAIRED BY WELDING CQP 401 REV 5	X-RAY PER TECHNIQUE: To be determined. USE CALIBRATED DENSITOMETER FOR DENSITY VERIFICATION. ATTACH TECHNIQUE, READER SHEET FOR ALL RADIOGRAPHS. MUST INDICATE RADIOGRAPHER AND ASNT CERTIFICATION LEVEL ON READER SHEET.	RT - LEVEL II	<i>NA</i>
300	X-RAY CQP 401 REV 5	X-RAY INTERPRETATION. ACCEPTANCE MSS SP 54. ATTACH TECHNIQUE, READER SHEET FOR ALL RADIOGRAPHS. MUST INDICATE RADIOGRAPHER AND ASNT CERTIFICATION LEVEL ON READER SHEET. IF OK CHECK HERE _____ AND SEND TO STEP 310. REJECTED CHECK HERE _____ MARK UP DEFECTS AND SEND THE CASTING TO STEP 200.	RT - LEVEL II	
	REPEAT	REPEAT STEPS __200 TO 300__ AS REQUIRED TILL WELDS CLEAR X-RAY. DOCUMENT REWORK ON A SUPPLEMENTAL MTS	QA ENG.	
310	SAND BLAST BLAS SOP 0100R6	SANDBLAST (REMOVE ALL BLAST MATERIAL FROM CASTING) SANDBLASTING WILL BE DONE USING RECYCLED SHARP ANGULAR AGGREGATE.		<i>MW</i> <i>10/31/05</i>
NOTICE	WITNESS NOTIFICATION	PROVIDE NOTICE TO EIO AND DCMA AT LEAST FIVE DAYS IN ADVANCE OF VISUAL AND LP STEPS. EIO NOTIFIED ON <u>10/23</u> DCMA NOTIFIED ON <u>10/23</u>	Q ENG OR QA MGR	<i>RMS</i>
320	FINAL VISUAL INSPECTION CQP-500 REV 4	VISUALLY INSPECT 100% of COMPONENT ACCORDING TO ASTM A802 LEVEL 2 ALL CONDITIONS. IF OK CHECK HERE <input checked="" type="checkbox"/> IF REJECTED CHECK HERE _____ . MARK AND REPAIR AT STEP 340.	VT - LEVEL II	<i>KA 10-31-05</i>

Energy Industries of Ohio

FIVE PARTS KEEP TOGETHER

Manufacturing and Test Sequence (MTS) Coill C Shim

CO# 40851, Pattern SE 141-073 -3 MS73220-2 Dated December 14, 2004 Revision:Original

Page 5 of 6

Dated Issued:4-27-05

		MUST BE PERFORMED BY LEVEL II in VT.		
330	FINAL L.P. CQP 0300 REV 10	FINAL L.P. 100% OF COMPONENT. ACCEPTANCE PER ASTM A903. ACCEPTANCE CRITERIA- LEVEL 1 FOR HIGH STRESSED AREAS, LEVEL 2 FOR ALL OTHER AREAS. SEE LP DRAWING. IF OK CHECK HERE <input checked="" type="checkbox"/> WASH AND SEND TO STEP 410. IF REJECTED CHECK HERE <input type="checkbox"/>	LP - LEVEL II <i>KLA</i> <i>10-31-05</i>	
340	WELD SOP 0100 REV 7	EXCAVATE ANY DEFECTS FOUND DURING FINAL PENETRANT INSPECTION.	<i>N/A</i>	
350	L.P. EXCAVATION CQP-300 REV 10	L.P. ALL EXCAVATIONS PRIOR TO WELDING TO ENSURE REMOVAL OF DEFECT. ACCEPTANCE PER A903.	LP - LEVEL II	
370	WELD MAP	MAP ALL WELDS WITH DIGITAL PHOTO/MAPS. SERIALIZE DEFECTS ON CASTING, USE SCALE IN PHOTOS AND DOCUMENT SIZE. THIS IS TO BE PERFORMED BY SUPERVISOR, INSPECTION LEAD MAN OR THEIR DESIGNEE. FILE WITH QA. MUST SEND REPORT ON ALL WELDS OVER 10% OF NOMINAL WALL THICKNESS TO CUSTOMER. NOMINAL WALL THICKNESS TO CUSTOMER. DEFECTS >10% YES _____, REPORT SENT BY _____ DATE _____ DEFECTS < 10 % _____ SIGN BY QA ENG.		
380	WELD SOP 0100 REV 7	WELD REPAIR DEFECTS AS MARKED. FOR WELDS <2" - WPS 10-SMAW-CF8MNMN MOD REV 1 FOR WELDS <8" - WPS 15-GMAW-CF8MNMN MOD REV 2		
390	GRIND GCHI SOP 0100 REV 2	HAND GRIND WELDS.		
400	L.P. WELDS CQP 0300 REV 10	L.P. WELD REPAIRS ACCEPTANCE PER ASTM A903. IF OK CHECK HERE <input type="checkbox"/> WASH AND SEND TO STEP 460. IF REJECTED CHECK HERE <input type="checkbox"/> AND RETURN TO STEP 390.	LP - LEVEL II	
	REPEAT	REPEAT STEPS 390 TO 410 AS REQUIRED TILL WELDS CLEAR FINAL LIQUID PENETRANT INSPECTION. DOCUMENT REWORK ON A SUPPLEMENTAL MTS	QA ENG.	
410	TEST MAG PERM SOP MAG PERM 100, REV 1	TEST MAG PERMEABILITY REPAIR AREAS. RECORD ON WELD MAP LIST. TEST AT LEAST 5 POINTS PER WELD. ACCEPTANCE 1.02. IF OK CHECK HERE <input type="checkbox"/> AND GO TO STEP 430.		

Energy Industries of Ohio

FIVE PARTS KEEP TOGETHER

Manufacturing and Test Sequence (MTS) Coill C Shim

CO# 40851, Pattern SE 141-073 -3 MS73220-2 Dated December 14, 2004 Revision:Original

Page 6 of 6

Dated Issued:4-27-05

420	GRIND GCHI SOP 0100R2	GRIND AREAS OF NON COMPLIANCE AND RETURN TO STEP 420. REPEAT UNTILL COMPLIANCE IS ACHIEVED.	NA	
NOTICE	WITNESS NOTIFICATION	PROVIDE NOTICE TO EIO AND DCMA AT LEAST FIVE DAYS IN ADVANCE OF MAG PERM STEP. EIO NOTIFIED ON <u>10/23</u> DCMA NOTIFIED ON <u>10/23</u>	Q ENG OR QA MGR	<i>lms</i>
430	FINAL MAG PERM INSPECTION SOP MAG PERM 100, REV 1	PERFORM MAG PERM TESTING WITH SEVRIN GAUGE. ACCEPTANCE 1.02. CHECK THE ENTIRE SURFACE ON A 6"BY6" GRID. REPORT RESULTS. USE A 6" SQUARE BLOCK TO INDICATE TEST LOCATIONS AND RECORD RESULTS. COMPLIANT AREAS WILL NOT BE MARKED. MARK NONCOMPLIANT AREAS WITH AN "X" FOR REPAIR. OK CHECK HERE <input checked="" type="checkbox"/> AND GO TO STEP 470. IF REJECTED CHECK HERE	<i>cto</i>	<u>10/28</u>
440	GRIND GCHI SOP 0100 REV 2	HAND GRIND WITH SUITABLE CONE OR OTHER SIMILAR GRINDER AS REQUIRED TO ENSURE REMOVAL OF MATERIAL TO ACHIEVE MAG PERM REQUIREMENT. CIRCLE AREA REMEDIATE FOR RETEST.	NA	
450	RETEST MAG PERM SOP MAG PERM 100, REV 1	RETEST MAG PERMEABILITY AT FAILED TEST POINTS. MARK NONCOMPLIANT AREAS WITH AN "X" FOR REPAIR. ACCEPTANCE 1.02. IF OK CHECK HERE . IF REJECTED CHECK HERE RETURN TO STEP 450		
460	PHOTOGRAPH	TAKE DIGITAL PICTURES.	<i>JCS</i>	<u>10/31/05</u>
470	AUDIT REVIEW	PROCESS DOCUMENT TO PROGRAM MANAGER FOR COMPLIANCE AUDIT.	<i>cto</i>	<u>10/31/05</u>
480	DOC. REVIEW	REVIEW DOCUMENTS AS REQUIRED IN CAF CHECKLIST, ALL DOCUMENTS NOTED TO BE ACCESSIBLE FOR AUDITING. (SHIPPER, C OF C, M.T.R., M.T.S., INSPECTION REPORT, X-RAY READER SHEETS AND HEAT TREAT CHARTS)	<i>cto</i>	<u>10/31/05</u>
NOTICE	RELEASE FROM EIO	PROVIDE DOCUMENTS TO EIO. SENT ON <u>11/1</u> BY <u>cto</u> . RECEIVED RELEASE FROM EIO ON _____.	Q ENG OR QA MGR	
490	PACK AND SHIP	PACKAGE AND SHIP TO MAJOR TOOL.		
1000	REVISION HISTORY	ORIGINAL 12-14-04.	CARUUD	



Corrective Action 1308
Carondelet Division - CA / PA / RGA Database
Corrective Action Type NCR
Date 6/13/2005
CA Originator C. Ruud
Pattern Number: C and A Coil Shims 11 Pieces

Description of Defect / Non-Conformance

Chemistry for 11 shim castings is out of specification.

Root Cause

Chemistry specification was not changed in system and not communicated to Lab personnel.

Corrective Action

Specification was corrected in system and Lab personnel trained. Mag permeability was checked on the parts and are less than 1.02u.

Verification of Corrective Action

Chemistries were checked on subsequent parts and are within specification.

Preventive Action

Create Inspection and Test Plan summarizing all requirements.

Estimated Completion Date

6/15/05

Actual Completion Date

Complete.

A handwritten signature in black ink, appearing to read "C. Ruud". The signature is fluid and cursive.

Signed: C. Ruud

CC: Roger Broman, Barry Craig, Joe Edwards, E.J. Kubick

Nonconformance Report: MetalTek CA 1308

Project Disposition: Use as is.

Approvals

Procurement Technical Representative _____
Wayne Reiersen for Phil Heitzenroeder

Responsible Line Manager _____
Mike Cole for Brad Nelson

Nonconformance Report: CA 1323 (phosphorus levels exceeds specification limits for castings C1- C4 and A1 and C1 shim and four Type C and six A coil shims)

Project Disposition:

The erroneous levels were due to calibration errors with the spectrometer. As reported in MTK's attached report, preventive maintenance has since been performed on the spectrometer. The reported chemistry will be accepted for the castings and shims noted above. The specification chemistry will not be changed at this time.

Approvals:

**Phil
Heitzenroeder**

Digitally signed by Phil Heitzenroeder
DN: CN = Phil Heitzenroeder, C = US,
O = PPPL, OU = Mech. Eng. Division
Reason: I agree to 'specified' portions
of this document
Date: 2006.02.21 11:49:56 -05'00'

Procurement Technical Representative

**Brad
Nelson**

Digitally signed by Brad Nelson
DN: cn=Brad Nelson, c=US,
o=ORNL, ou=FED,
email=nelsonbe@ornl.gov
Date: 2006.02.21 14:16:12
-05'00'

Responsible Line Manager:



Corrective Action 1323
Carondelet Division - CA / PA / RGA Database
Corrective Action Type NCR
Date 7/27/2005
CA Originator C. Ruud
Applies to: Coil castings C-1, C-2, C-3, C-4 and A-1 and C 1 shim and four C coil and six A coil shims

Description of Defect / Non-Conformance

Phosphorus levels in material produced to date exceed specification limits. Both phosphorus and sulfur readings reported erroneously in certifications.

Certification reports have shown phosphorus and sulfur levels in the <.01% range. Independent laboratory data confirmed phosphorus in the .018 to .033% range and sulfur in the .005 to .022% range. Actual levels of some tests are above those in PPPL Specification NCSX-CSPEC-141-03-07 Rev 7.

Nonconformance was first suspected as a result of analysis of zoned attached test specimens volunteered by MetalTek International as response to PPPL questions on weighted average chemical analysis and quality of blending in the gating system. Nonconformance was verified on the bars used in the study and has been extended to evaluation of previously poured products.

Root Cause

Specification limits were set below the levels achievable through use of available raw materials. Spectrometer did not properly calibrate for phosphorus and sulfur at levels of specification due to equipment malfunction.

The chemical specification of EIO heats uses alloy CF8MNMn-Mod which incorporates a type standard calibration with a certified reference material (CRM) BS180. This enables the operator of the spectrometer to match the elemental concentrations of this alloy with corrective factors. These factors are determined by analyzing the CRM and having them compared with the calibration curves for each element. The phosphorus and sulfur content have very low measured intensities due to low concentrations. Intermittent failure of the spectrometer intensity measuring card caused higher intensity readings for phosphorus and sulfur. Subsequent checks with the CRM resulted in low corrective factors that were not detected. This in turn resulted in low reported concentrations for the EIO samples. All the major elements, which are measured on other intensity cards, have been closely monitored and matched very well with the CRM and thus were reported correctly.

Corrective Action

Modification to specification for phosphorus and sulfur will be requested. Limits will be set based on process capability and consistent with other stainless steel grades. Replacement of deficient card in spectrometer will be made upon delivery.

Subsequent immediate analysis of chemistry results, obtained by wet analysis, is attached and demonstrate top of specification for sulfur and over specification for phosphorus. The spectrometer manufacturer has performed an analysis to determine the cause of the malfunction and verified that the intensity card has an intermittent fault and must be replaced. The card has been ordered and scheduled for replacement on August 15, 2005.

Until the card is replaced we will be performing additional type standardizations to ensure accurate sulfur and phosphorus analysis. Additionally, for coils made until the card is replaced, an independent laboratory will perform a verification of the chemical analysis.

Verification of Corrective Action

Will be determined at a later date.

Preventive Action

In addition to spectrometer faults, we have identified that the specification ranges for sulfur and phosphorus is unattainable. Analysis and specifications for virgin charge materials predict sulfur at 0.040% maximum and phosphorus at 0.040% maximum. We have no way to remove phosphorus from the melt and do not intentionally add phosphorus. So, the confirmed coil analyses, along with analyses of virgin material heats, demonstrate sulfur in the range of 0.010% to 0.022% and phosphorus in the range of 0.018% to 0.033%. These results are consistent with our charge material analysis. We will request a deviation for phosphorus in the subject parts and also request a permanent specification change to 0.040% maximum for both phosphorus and sulfur, to allow us to provide non-discrepant material. This change will not affect, in any way, the physical properties or material performance because all coils and test material exhibited sulfur and phosphorus within the new ranges despite inaccurate reporting. Other actions: Specifications have been added to the BS 180 standard and the type standard will be measured against the criteria.

Estimated Completion Date

August 15, 2005

Actual Completion Date TBD

Signed: C. Ruud



CC: Jim Galaske, Barry Craig, Joe Edwards, E.J. Kubick

Guide to St Louis Testing Report Dated 7-26-05

Sample name	Sample origin
A1Z1	Cast on bar A-1 coil, zone 1
A1Z2	Cast on bar A-1 coil, zone 2
A1Z3	Cast on bar A-1 coil, zone 3
C1	Cast on bar C-1 coil
C2Z1	Cast on bar C-2 coil, zone 1
C2Z2	Cast on bar C-2 coil, zone 2
C2Z3	Cast on bar C-2 coil, zone 3
C3Z1	Cast on bar C-3 coil, zone 1
C3Z2	Cast on bar C-3 coil, zone 2
C3Z3	Cast on bar C-3 coil, zone 3
F1	Final analysis button from ladle for C-4 coil
F2	Final analysis button from ladle for C-4 coil
F3	Final analysis button from ladle for C-4 coil
P1	Preliminary analysis button from ladle for C-4 coil

Testing is underway of the heat used to pour the four C coil and six A coil shims.

*Attachment to
CA 1323*



Chemical, Metallurgical, Mechanical, Nondestructive, Environmental Testing, Analyses and Field Service.

July 26, 2005
Lab No. 05C-0608
Invoice No. 59891
P.O. No. 21324
Page 1 of 1

METALTEK INTERNATIONAL
8600 Commercial Blvd.
Pevely, MO 63070

Attention: Chuck Ruud

REPORT OF CHEMICAL ANALYSIS

SAMPLE ID: A1 Z1, A1 Z2, A1 Z3, C1, C2 Z1, C2 Z2, C2 Z3,
C3 Z1, C3 Z2, C3 Z3, F1, F2, F3, P1

RESULTS: %

ANALYTE	A1Z1	A1Z2	A1Z3
Sulfur	.013	.005	.010
Phosphorus	.025	.023	.018

ANALYTE	C1	C2Z1	C2Z2	C2Z3
Sulfur	.014	.022	.018	.015
Phosphorus	.018	.024	.021	.025

ANALYTE	C3Z1	C3Z2	C3Z3
Sulfur	.013	.014	.012
Phosphorus	.024	.025	.021

ANALYTE	F1	F2	F3	P1
Sulfur	.014	.015	.012	.010
Phosphorus	.029	.033	.028	.030

Sulfur Test Method: ASTM E1019-03

Phosphorous Test Method: Colormetric

Identification of tested specimen provided by the client.

Robin E. Sinn
Laboratory Director





Corrective Action 1379
Carondelet Division - CA / PA / RGA Database
Corrective Action Type NCR
Date 8/31/2005
CA Originator C. Ruud
Applies to: Weld Material Lincoln 3018926-78309

Description of Defect / Non-Conformance

Material failed elongation and one of three Charpy impact tests at -320 F. The average of the specimens exceeds the minimum. See S8 of ASTM A 703/A 703M.

Root Cause

The sample of the weld contained defects not detected.

Corrective Action

Retest material already at Lab.
If needed, make a new weld plate after reviewing process with welder and weld another sample.

Verification of Corrective Action

Retest results. If new plates are needed, the new plate will be x-rayed prior to testing.

Estimated Completion Date

9-2-05

Actual Completion Date TBD

Signed: C. Ruud

A handwritten signature in black ink, appearing to be "C. Ruud".

CC: R. Suria, Barry Craig, Joe Edwards, E.J. Kubick

Nonconformance Report: CA1379

Project Disposition:

Since the re-test meets requirements, this NCR can now be considered closed.

Approvals:

Phil
Heitzenroeder

Digitally signed by Phil Heitzenroeder
DN: CN = Phil Heitzenroeder, C = US,
O = PPPL, OU = Mech. Eng. Division
Reason: I am approving this document
Date: 2005.11.07 10:09:53 -0500

Procurement Technical Representative

 11/7/05

Responsible Line Manager:



Corrective Action 1423
Carondelet Division - CA / PA / RGA Database
Corrective Action Type NCR
Date 10/20/2005 Revised 10-25-05
CA Originator C. Ruud

Applies to: Weld Material Metrode Lot WO21735 and Lot WO19711 used on C-2 and C-4 coils.

Description of Defect / Non-Conformance

Material does not meet the requirements of NCSX CSPEC – 141-03-09.

Root Cause

The specification was to have included chemical ranges to accommodate the different kinds of weld material used and accepted for the weld procedure qualifications.

Corrective Action

Revise specification.

Estimated Completion Date

Actual Completion Date TBD

A handwritten signature in black ink, appearing to be "C. Ruud".

Signed: C. Ruud

CC: R. Suria, Barry Craig, Joe Edwards, E.J. Kubick

Nonconformance Report: 1423

Project Disposition:

Rev. 10 of NCSX-CSPEC-141-03 now includes two tables for weld wire chemistry (3-1 and 3-2) to permit the use of both bare weld wire and coated wire electrodes.

Approvals:

Procurement Technical Representative

Responsible Line Manager:



Corrective Action 1433
Carondelet Division - CA / PA / RGA Database
Corrective Action Type NCR
Date 10-27-05
CA Originator R. Suria
Applies to: C-4 Coil

Description of Defect / Non-Conformance

R-2 weld repairs. >.060" requirement not achieved on the inner rail.

Root Cause

Original casting defect that meet Level II requirements.

Corrective Action

Weld upgrade to meet the <.060 requirement.

Verification of Corrective Action

Re x-ray the defective welds.

Estimated Completion Date

10/27/05 for repairs.

Actual Completion Date

10/27/05

A handwritten signature in black ink that reads "R. Suria" with a stylized flourish at the end.

Signed: R. Suria

CC: C Ruud, B. Craig, J. Edwards, E.J. Kubick



Carondelet Division

8600 Commercial Blvd. - Pevely, MO 63070 USA
Phone: 636-479-4499 - Fax: 636-479-3399

Final Inspection Report

Customer Name: ENERGY INDUSTRIES OF OHIO

Pattern: MCWF-C 4 COIL

Order Number: PPPL-FP-LTS-2

ASTM Metal CF8MNMN MOD

Date 10/26/2005

Type Description	Cert Number	Procedure	Acceptance Criteria	Actual
Liquid Penetrant	S75920-3	CQP - 300 Rev 9	SEE NOTE	Acceptable
Notes Acceptance per ASTM A903. Acceptance criteria - level 1 for high stressed areas, level 2 for all other areas.				
Mag Perm	S75920-3	SOP Mag Perm 100 Rev 1	<1.02	Acceptable
Radiographic	S75920-3	Technique # 12726	MSS SP 54	Acceptable
Visual	S75920-3	CQP - 500 REV 4	ASTM A802 LEVEL 2	Acceptable

Liquid Penetrant

Technician: Jason Rees
ASNT Level II

Visual

Technician: Kevin Anderson
ASNT Level II

Respectfully Submitted,
Charles A. Ruud
Quality Assurance Manager



Carondelet Division

8600 Commercial Blvd. - Pevely, MO 63070 USA
Phone: 636-479-4499 - Fax: 636-479-3399

Certificate of Conformance

ENERGY INDUSTRIES OF OHIO

Order Number PPPL-FP-LTS-2

Pattern MCWF-C 4 COIL

ASTM CF8MNMN MOD

Date 10/26/2005

Cert Number

S75920-3

A handwritten signature in black ink, appearing to read "Charles A. Ruud".

We certify that we have complied in accordance with the drawings(s) and specifications(s) listed on the above purchase order. The articles furnished were made and/or processed from parts and/or materials in accordance with all applicable drawings(s) and specifications(s) pursuant to the afore mention purchase order.

Respectfully Submitted,
Charles A. Ruud
Quality Assurance Manager

Superior Quality Engineered Metal Products

www.MetalTekInt.Com



Carondelet Division

8600 Commercial Blvd. - Pevely, MO 63070 USA
Phone: 636-479-4499 - Fax: 636-479-3399

Final Inspection Report

Customer ENERGY INDUSTRIES OF OHIO
Pattern: SE-141-073 COIL C SHIM
S/N 3

Order PPPL-FP-LTS-2

ASTM Metal CF8MNMN MOD

Date 10/28/2005

Type Description	Cert Number	Procedure	Acceptance Criteria	Actual
Liquid Penetrant	S73220-2	CQP - 300 Rev 9	ASTM A903 Level II	Acceptable
Mag Perm	S73220-2	SOP Mag Perm 100 Rev 1	<1.02	Acceptable
Radiographic	S73220-2	Technique # 12726	MSS SP 54	Acceptable
Visual	S73220-2	CQP - 500 REV 4	ASTM A802 LEVEL 2	Acceptable

Liquid Penetrant

Technician: Kevin Anderson
ASNT Level II

Visual
Technician: Kevin Anderson
ASNT Level II

Respectfully Submitted,
Charles A. Ruud
Quality Assurance Manager

Superior Quality Engineered Metal Products

www.MetalTekInt.Com



3

Carondelet Division

8600 Commercial Blvd. - Pevely, MO 63070 USA
Phone: 636-479-4499 - Fax: 636-479-3399

Certificate of Conformance

ENERGY INDUSTRIES OF OHIO

Order Number PPPL-FP-LTS-2

Pattern SE-141-073 COIL C SHIM

S/N 3

ASTM CF8MNMN MOD

Date 10/28/2005

Cert Number

S73220-2

C shim for C-4 coil was poured from heat number 29198. No weld repairs were necessary.

A handwritten signature in black ink, appearing to read "CAR", is located in the lower right quadrant of the page.

We certify that we have complied in accordance with the drawings(s) and specifications(s) listed on the above purchase order. The articles furnished were made and/or processed from parts and/or materials in accordance with all applicable drawings(s) and specifications(s) pursuant to the afore mention purchase order.

Respectfully Submitted,
Charles A. Ruud
Quality Assurance Manager

Superior Quality Engineered Metal Products

www.MetalTekInt.Com

EIO
Energy Industries of Ohio
SUPPLIER QUALITY RELEASE

	Date: 10-31-05
--	----------------

I. General Information:		
Project Name:	Modular Coil Winding Form C4	
PO No:	NCSX-SOW-141-02-01	Rev.:
Supplier:	MetalTek	
Procurement Agent:	EIO	
Shipment:	<input checked="" type="checkbox"/> Partial <input type="checkbox"/> Final	

II. Material Description	
Casting C4 Coil	

III. Release Checklist	
Plan Requirements Complete?	<input checked="" type="checkbox"/> Yes <input type="checkbox"/> No <input type="checkbox"/> N/A (If identified "No" provide explanation in comments section below)
Variations?	<input checked="" type="checkbox"/> Yes <input type="checkbox"/> No <input type="checkbox"/> N/A (If identified "No" provide explanation in comments section below)
Princeton Notified of Shipment?	<input checked="" type="checkbox"/> Yes <input type="checkbox"/> No <input type="checkbox"/> N/A (If identified "No" provide explanation in comments section below)
DCMA Notified of Shipment?	<input checked="" type="checkbox"/> Yes <input type="checkbox"/> No <input type="checkbox"/> N/A (If identified "No" provide explanation in comments section below)
<input checked="" type="checkbox"/> Conditional <input type="checkbox"/> Unconditional	Explain conditional releases in comments section.

IV. Comments	
Variations – See attached package for CA's and deviations Pending stress relief chart & final reports	

By signing below you acknowledge that the casting has met all applicable standards and contractual requirements

V. Supplier Quality Representative Sign Off		
Charles Ruud	X 	10-31-05
Supplier Quality Representative (SQR) Print/Type Name	Supplier Quality Representative (SQR) Signature	Date

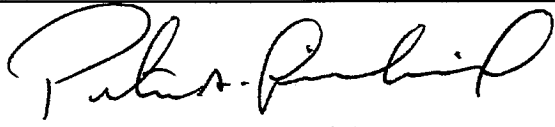
VI. Supplier Approval For Shipment		
Procurement Agent Notified of Shipment	Date: 10-31-05	
Required Vendor Data Ready for Shipment	Date: 10-31-05	
Peter A Djordjevich	X 	10-31-05

EIO
Energy Industries of Ohio
SUPPLIER QUALITY RELEASE

		Date: 10-31-05
--	--	----------------

I. General Information:		
Project Name:	Modular Coil Winding Form C4	
PO No:	NCSX-SOW-141-02-01	Rev.:
Supplier:	MetalTek	
Procurement Agent:	EIO	
Shipment:	<input checked="" type="checkbox"/> Partial <input type="checkbox"/> Final	
Supplier's Representative Print/Type Name	Supplier's Signature	Date

1. Enter:
Project Name
PO Number
Supplier
Procurement Agent

2. Enter a brief description of items being released, including applicable drawing number(s), dash or item number(s), drawing revision letter, specification(s), and serial number(s).

3. Self-Explanatory

4. Record any unusual circumstance, such as a conditional release.

5. The Supplier's representative shall sign and date.

7. Signature and date of the Supplier's authorized representative indicating shipping date.

8. In case of partial release, the supplier shall maintain copies of each sequential "Supplier Quality Release" and establish complete accountability of material release on final shipment.

9. Supplier shall include a copy of the completed form with each shipment.