

NCSX
Design Basis Analysis
Rev 2
Coil Support Structure Analysis
NCSX-CALC-15-001-02

8 January 2009

Prepared by:

F. Dahlgren, PPPL

*I have reviewed this calculation and, to my professional satisfaction, it is properly performed and correct.
I concur with analysis methodology and inputs and with the reasonableness of the results and their interpretation.*

Reviewed by:

H.M. Fan, PPPL, Engineer

Controlled Document

THIS IS AN UNCONTROLLED DOCUMENT ONCE PRINTED.

Check the NCSX Engineering Web prior to use to assure that this document is current.

Executive Summary:

- 1. All supports are within allowables for the most severe normal (& flexibility mode) EM operational loads, including gravity and cooldown (CTE differential induced stresses).**
- 2. Thermally induced stresses are considered as secondary stresses (ie. Self limiting) and are permitted to reach but not exceed $3 \times S_m$.**
- 3. Some areas of the structure will exceed secondary stress limits when thermal differentials exceed 40 deg.C and would require further analysis if these differentials are anticipated during cooldown or warm-up cycles, or during normal or off-normal (ie. Undetected loss of coolant) operations. Under normal operating conditions no coil system exceeds 30 K differential temperature.**
- 4. In general, the PF & TF supports are not severely challenged by the highest EM loading conditions analyzed which included trim coil effects, and the most severe flexibility mode loading defined, however, the MCWF joints should be checked for the updated loading. Also the welded joint stresses should be reviewed in addition to the bolted joint stresses.**
- 5. Only limited fault analysis (on C.S. coil/structure) has been performed, but stresses for these fault conditions are well within allowables. Analysis of additional fault loading conditions would be advisable were this project to be pursued (TBD).**
- 6. A detailed analysis of all bolted joint stresses is TBD, however the bolting material is Inconel 718 with considerably higher stress allowables than 316ss (37 ksi vs. 20ksi @R.T.). Analysis of bolting stresses with local models (TBD) would be advisable were this project to be pursued.**
- 7. The analysis of the .5T TF only was performed and found to be a safe operating current for the TF system. A combined operating limit with MC & PF coils is TBD.**
- 8. Seismic analysis of the base supports using 0.17g lateral static acceleration produced stresses and displacements within the project allowables.**

Introduction

The Coil Support Structure is connected to the Base Support Structure (WBS 17) at six locations, and provides the load path (via the MCWF shell) for the dead weight of the entire NCSX core, which includes the MCWF shell and modular coils as well as the conventional PF, TF, and Trim coils. In addition to the gravity loading, the supports must also provide the load path for all EM and thermally induced forces in the coils. These forces are transmitted to the MCWF shell castings which provides the main structural core of the machine. The TF coils are supported off the MCWF shell at 72 locations (36 top & bottom). These supports are comprised of welded lateral brackets and the top bridge plates which bolt to them. There are G10 shims between the lateral brackets and bridge and the TF coils. The supports have lateral pre-load jacks that grip the TF coil sides, while the bridge plates provide vertical clamping. A cut away view of the TF bracket structure without the top bridge plate is shown in figure 1 below.

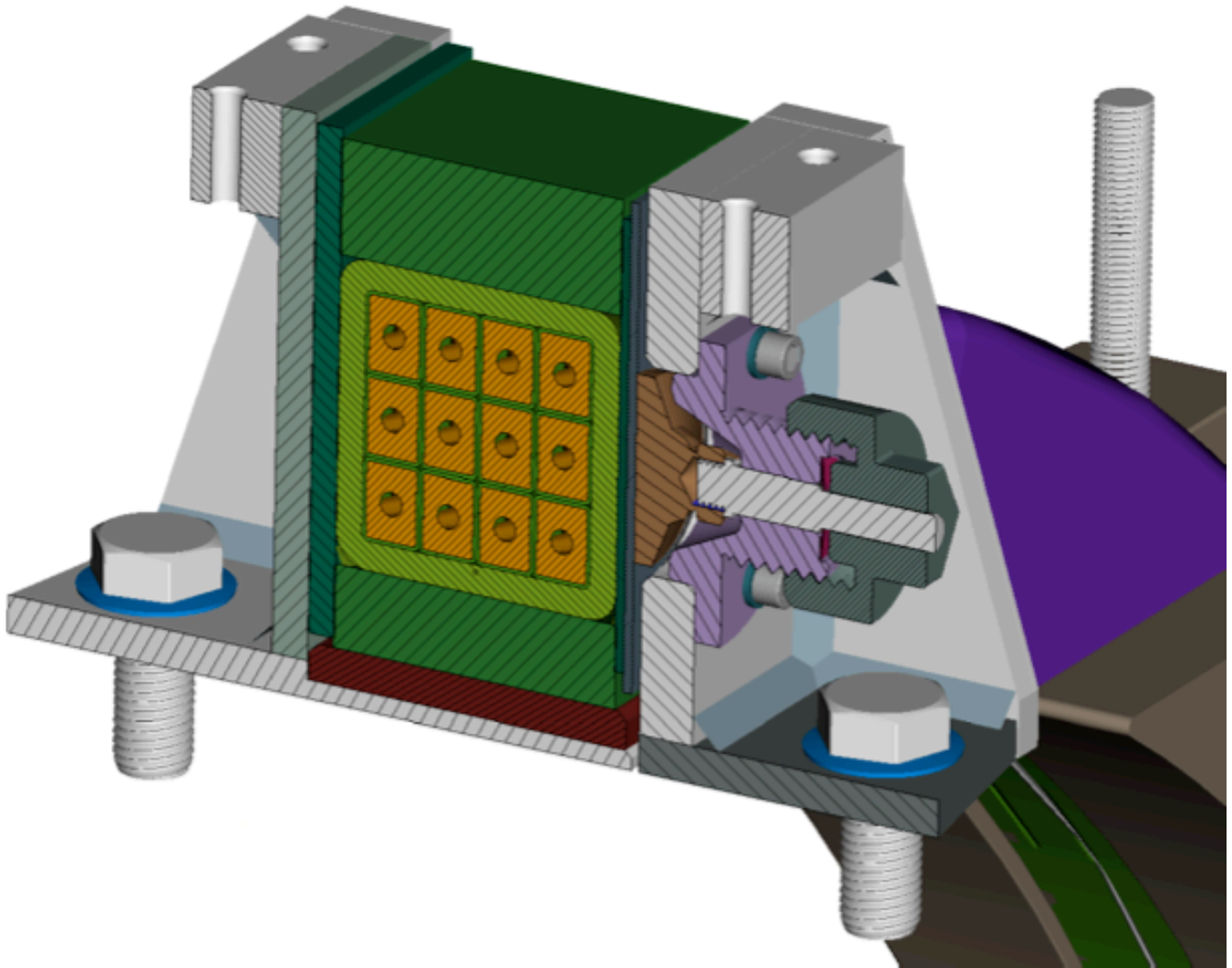

Figure 1. The TF Coil support bracket – inner support cut-away view

All EM loads will be reacted within the MCWF shell structure and TF-PF interconnections. The PF coil supports are cantilevered off the TF coil brackets (see figures 2a & 2b) and are also modeled with Quad and Tria plate elements as seen in figure 3 below. The TF brackets are bolted directly to the MCWF shell castings or bolt to spacer weldments which bolt to the MCWF. The cantilevered PF-4 supports are bolted to the inner TF brackets as shown in figure 2a, and the PF5&6 supports bolt to the outer TF brackets, as seen in figure 2b. There are also vertical angle-columns which tie the PF-6 support feet together top to bottom.



Figure 2a. PF-4 coil supports

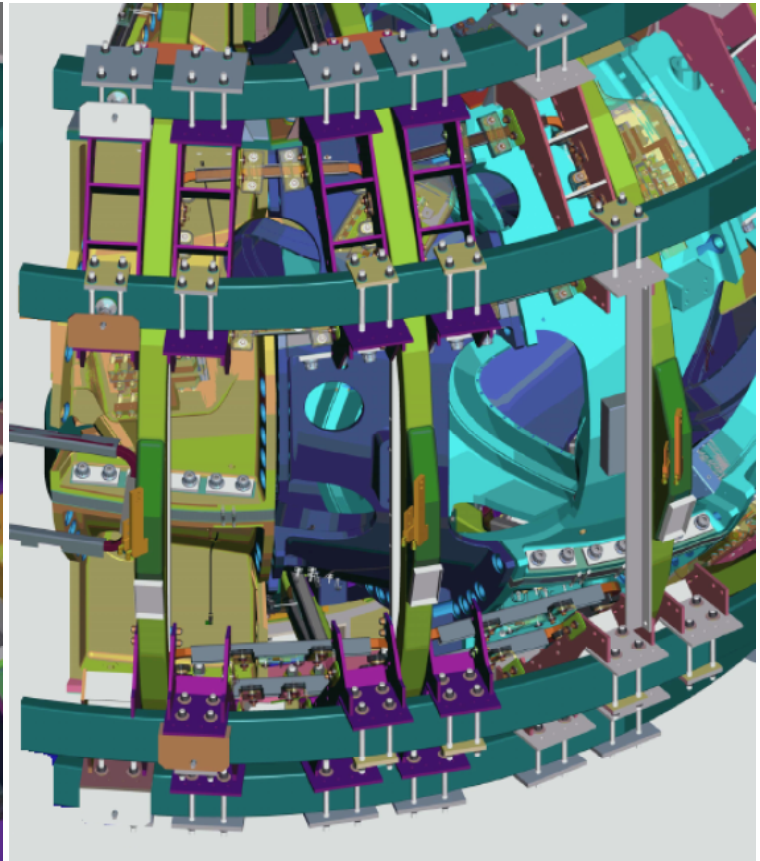

Figure 2b. PF 5&6 Coil supports

The outboard support columns are located 120 degrees apart at the C-C MCWF joints and at an elevation of 94" and at a nominal radius of 79.5". The inner support columns are located at 120 degree intervals at the A-A MCWF joints at an elevation of 90" and a nominal radius of 29.5". These interfaces must provide structural continuity between the floor, base structure, and coil structure for gravity and seismic loading. The six interfaces at the base/coil support structure will be bolted with G11 insulating plates, washers, and bushings, to provide both electrical isolation for ground loops, and thermal insulation to minimize heat transfer from the warmer base structure to the cold coil support structure. Spherical bearings will be used to allow for any angular misalignments between the MCWF/core structure and base supports and will also suppress moment constraints being transmitted to the MCWF due to rotational flexing of the modular coil structural shell. To provide radial compliance between the core and supporting structure, a low friction PTFE surface will be used between the column pedestal and spherical bearing lower clevis base plate. Z-shaped channels bolted to the base support pedestals will capture the sliding lower clevises to restrict lateral (circumferential) sliding and any vertical lifting of the core (resulting from seismic over-turning motions). All gravity loads and loads from any seismic events are reacted through these interfaces, through the base support columns and base frames to the test cell floor, and ultimately, to the C-Site basement floor.

The current analysis evaluates the adequacy of the TF & PF coil support brackets, and interface connections when subjected to normal EM, gravity, seismic, and cooldown loading conditions. The analysis of the MCWF/core-base structure interface assembly (not including the spherical bearing housing covered in this report) is covered in the Coil Support Structure Design Basis Analysis (NCSX-CALC-17-001-00) which also includes a preliminary seismic analysis of the machine.

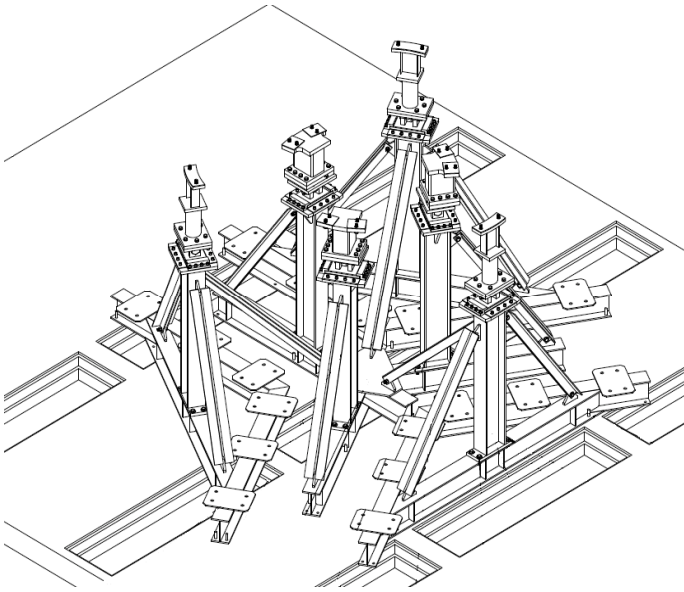

Figure 3. Base Support Structure For NCSX

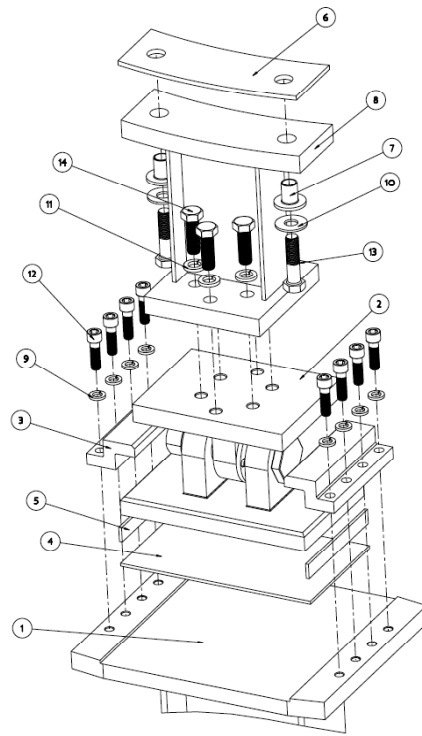

Figure 4. MCWF/core-Base Structure Interface

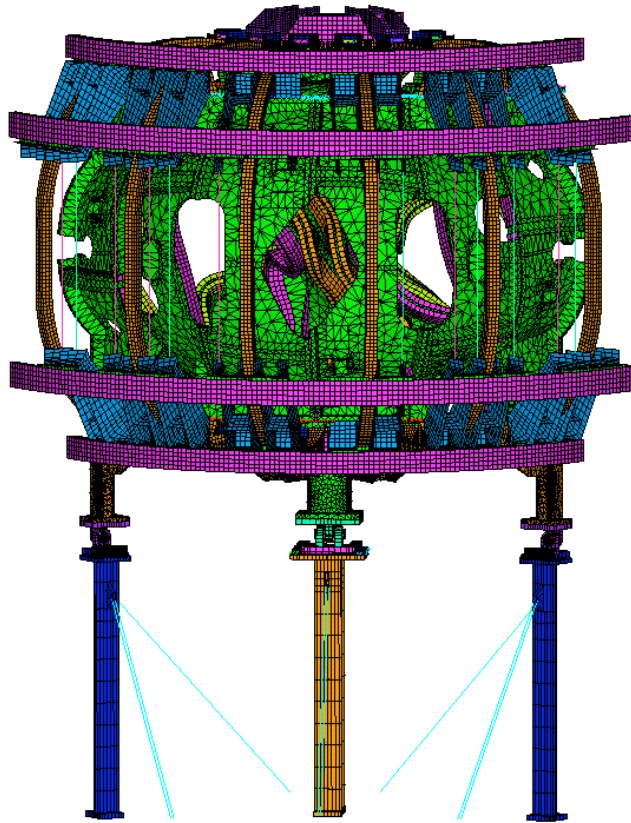

Figure 5a. Fully integrated model of NCSX single period

Methodology

The analysis of the coil support structure was accomplished using the ANSYS Finite Element Analysis program version 11.1. The FEA model of the base supports applies loads from gravity, and a static seismic loading based on the NCSX Seismic Design Criteria Document (NCSX-CRIT-SEIS-00). EM loads are derived from the electro-magnetic analysis results of initial runs utilizing currents/voltages specified for various coil system scenarios in the GRD.

Assumptions

The full weight of the stellarator core is assumed to be 300 kips, or 100 kip per period (Note, a scaled vertical acceleration has been used to apply the gravity loads for the core mass which has been calculated from the models' volume and mass density for all the various components).

The boundary conditions are at the bottom of the machine columns at the supporting test cell floor, and are assumed to be fixed in all 3 degrees of freedom thereby implying an infinitely stiff floor. Room temperature (295 K), secant (298 K to 77 K) CTEs, and isotropic material properties are assumed for all components.

$E_{\text{stainless}} = 29 \text{ e } 6 \text{ psi (200GPa) @R.T. } 31 \text{ e } 6 \text{ psi (214 GPa) @ } 77$ (all base support structural components)

$E_{\text{concrete}} = 3.12 \text{ e } 6 \text{ psi (21.5GPa)}$

$E_{\text{A36-stl}} = 30 \text{ e } 6 \text{ psi (207 GPa)}$

$E_{\text{MCWF}} = 27.8 \text{ e } 6 \text{ psi (192 GPa)}$ Stellarloy Stainless Castings

$E_{\text{PF\&TF}} = 14.2 \text{ e } 6 \text{ psi (97.9 GPa)}$ Copper/Epoxy-Glass mixed composite

$\mu = 0.2$ friction coefficient Spherical bearing to bearing housing

$\mu = 0.05$ friction coefficient for Teflon low friction sliding surfaces

Reference ANSYS Database files

NCSX-TP-PF-STRUCT-304g5h-all4a.db – Cooldn-77K+EM+G (EM: 1.7T-Ohmic at t=0.24 sec)

NCSX-TP-PF-STRUCT-304g5h-all4b.db – EM+G @R.T. (EM: 1.7T-Ohmic at t=0.24 sec)

NCSX-TP-PF-STRUCT-304g5h-all4c.db – Lateral 30 deg. 0.171g Seismic + 1.1G vert. @77K

NCSX-TP-PF-STRUCT-304g5h-all4d.db – Lateral 30 deg. 0.171g Seismic + 1.1G vert. @R.T.

Description

A finite element model of the NCSX coil support structure including base supporting columns is shown in Figure 5a. The model uses 20-node hexahedral solid (brick) elements for the column and beam webs, flanges, gussets, and end plates. The interface components between the base supports and core are generally modeled with 8-node and 20-node brick and 15-node pentahedral elements, including the spherical bearing and housing which provides the radial and rotational compliance for the interface. The MCWF is modeled with 10 node Tetrahedral elements, the modular coils with 8-node bricks, the TF and PF supporting brackets with quadrilateral and triangular plate elements. The TF bracket bridges are represented by 20-node bricks.

To interface the various structural components, several sets of contact elements are defined to represent the bolted connections (using an always bonded contact-target pair of surfaces), or sliding contact surfaces (by defining low friction coefficient contact-target surfaces). ANSYS internally generates sets of constraint equations at the gauss points on the surface of the interface elements based on an Euler-LaGrange

formulation. An index of the models' structural components referencing the various element material numbers can be found in Appendix IV.

A result of an examination of CAD and ANSYS models determined that the dead load of the entire Stellarator core was initially determined to be approximately 240 kips without the vessel liner, trim coils, coil services, neutral beam duct, and diagnostics. The dead load distribution between the outer and inner supports was determined from results of the integrated global model of the Stellarator core which is shown in tabular form in Appendix I with a factor of 1.25 to account for the items mentioned above which are not yet designed. Appendix II is a summary of all dead loads in the machine core including an estimate of the TBD components. To be conservative a factor of 5% over these estimates was used for this analysis. The complete (estimated dead load, including the 5%, is 300 kips or 100 kips per period). In general, based on Appendix I results, the gravity load will shift about 3.2 kips to the outboard supports due to EM loading and cool-down, producing a 53.2-46.8 kip load split outboard to inboard for a full period (120 degrees) during machine operations and about 51.6-48.4 kip split when sitting cold w/o EM loads applied.

As summarized in tables I & II, a complete review of all EM loading conditions determined that the 2T-Hi-beta scenario at $t=0.197$ seconds produced the worst case for stresses in the Modular Coils (MC) and MCWF while the 1.7T Ohmic scenario at $t = 0.100$ seconds was the most severe for PF and TF coil normal operations (included in this review were various iota configurations based on the additional flexibility requirements in the GRD). It should be noted that the 1.7T Hi-beta EM loading on the MCs was not included in the load cases applied in the analysis currently being reported although they have been accounted for in the 2T cases (HM Fans' FEA) reported in Appendix I. Since generally all the Modular Coil EM loads are reacted within the MCWF shell, it has been assumed that their effect on the PF and TF supports and base support interface elements should be marginal. This observation is also supported by the design intent of the spherical bearings which attach the machine to the base supports. These attachments provide full rotation compliance for the machine-base interfaces. The current analysis should be re-visited to verify this assumption if the NCSX project were to move forward.

Load Case	1	2	3	4	5
Scenario	0.5 T TF	1.7T Ohmic	2T High Beta	320kA Ohmic	320kA Ohmic
Time, s	0.0	0.0	0.0	0.206	0.506
M1 (A)	0	38141	40908	34200	34200
M2 (A)	0	35504	41561	32057	32057
M3 (A)	0	35453	40598	32184	32184
PF1 (A)	0	-25123	-15274	11354	21858
PF2 (A)	0	-25123	-15274	11354	21858
PF3 (A)	0	-9698	-5857	-11802	-5975
PF4 (A)	0	-7752	-9362	-13936	-9441
PF5 (A)	0	8284	1080	4563	4634
PF6 (A)	0	-8997	-24	5068	5705
TF (A)	16200	-3548	-1301	2191	2191
Plasma (A)	0	0	0	-320775	-320775

Red and blue fields represent maximum and minimum coil currents

Table I. Loading survey of NCSX coils – Maximum current per coil system

Coil	LC2	LC3	LC4	LC5
Central Solenoid	468 Attract	24 Attract	67 Attract	778 Attract
PF4	182 Attract	117 Attract	142 Attract	39 Repel
PF5	215 Repel	19 Repel	52 Repel	43 Repel
PF6	149 Attract	0	58 Repel	62 Repel

Table II. Maximum Net loads on PF coils

Test Temperature		0.2% Yield Strength		Tensile Strength		Elongation
°F	°C	psi	(MPa)	psi	(MPa)	Percent in 2" or 51 mm
-423	-253	100,000	690	250,000	1725	25
-320	-196	70,000	485	230,000	1585	35
-100	-79	50,000	345	150,000	1035	50
70	21	35,000	240	90,000	620	60
400	205	23,000	160	70,000	485	50
800	427	19,000	130	66,000	455	43
1200	650	15,500	105	48,000	330	34
1500	815	13,000	90	23,000	160	46

Table III – Typical yield & ultimate stresses for 304L @ R.T. & 77 deg.K
(source: Allegeny-Ludlum)

Since the 1.7T-Ohmic scenario produces the highest EM forces on the TF and PF coils it was chosen as the primary loading condition for this design basis analysis (Note, appendix II summarizes results of H.M.Fans' model runs which included runs for the 2T Hi-beta scenario –highest MC & PF6 loading, 0.5T TF currents –highest TF loading, and the two most severe iota flexibility loading conditions in addition to the various directions of trim coil loads on the coil support structure).

Load Case 1: 1.7T-Ohmic @t=0.240 sec. with gravity – no thermal effects.

Figure 5b below is a contour plot of the SRSS displacements due to the room temperature gravity loading condition. The plot is looking inboard with the zero degree azimuthal angle at the plot center and the model extending left and right ±60 degrees. The load distribution is essentially uniform at 50kips per support.

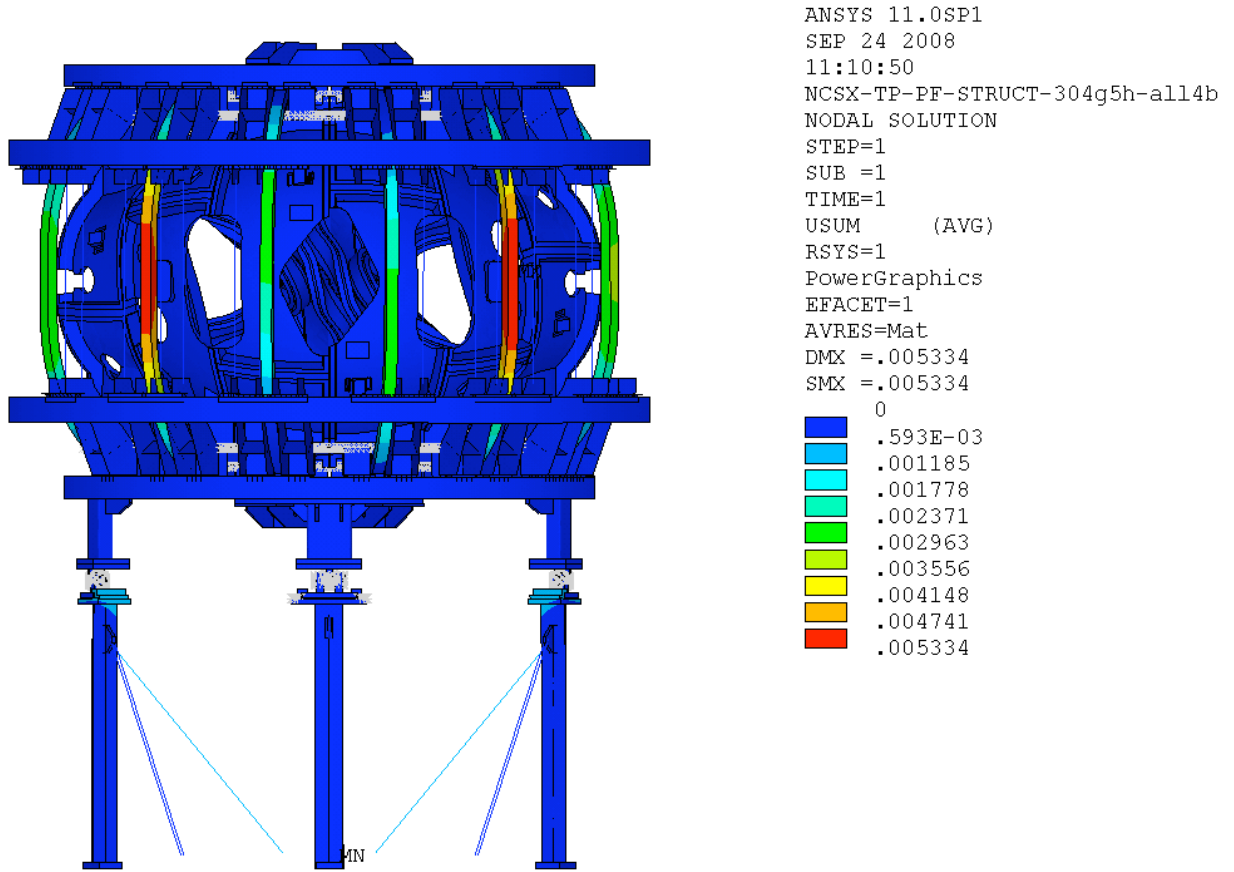

Figure 5b. SRSS Displacements due to gravity loading –Stellarator core at R.T. – 1.7T Ohmic

The peak vector sum (SRSS) displacement is 5 mm at the outer leg of the TF coils. The major component of this displacement is from bending due to circumferential displacement of coils 2 & 5 toward the zero degree vertical center plane of the machine. This is more clearly illustrated in figure 8 which plots the contours of circumferential displacements.

Figure 6 below is a contour plot of the vertical (dz) displacements due to room temperature gravity loading plus 1.7T Ohmic EM forces. The maximum vertical (downward) displacement is 1mm located at the brackets which connect the base support columns to the lateral braces (labeled MN in the figure). This displacement is due primarily to the local bending of the column web at this location (see the greatly exaggerated displacements in the insert in figure 6). The more representative peak vertical displacements of roughly -0.5 mm occur at right hand side of the PF6 coils with complementary upward displacements on the left hand side. This corresponds to the sinusoidal vertical forces applied. While column buckling is not an issue on the base columns, additional local stability can be effectively achieved by reinforcement of this area with gussets just above and below the lateral support bracket.

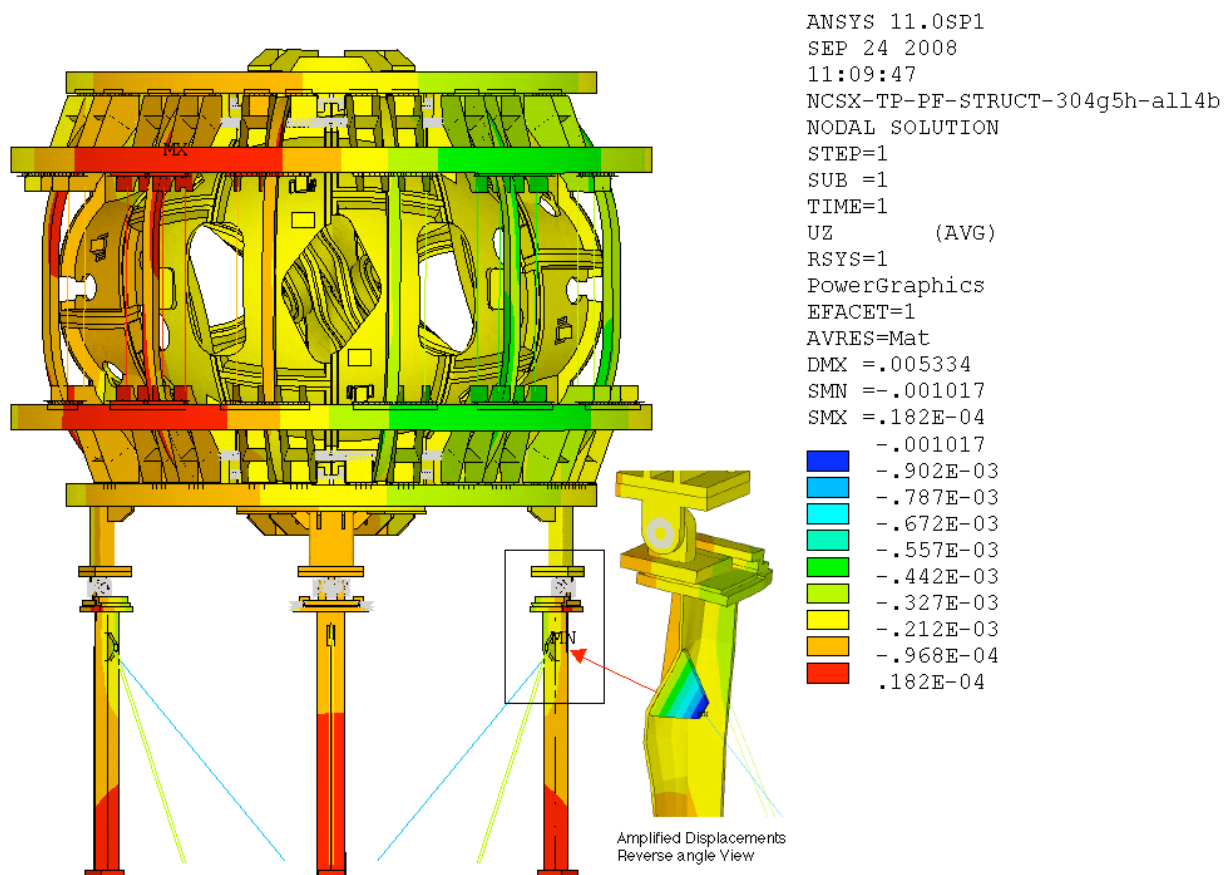

Figure 6 Vertical (dz) displacement contours -stellarator core at R.T. – 1.7T Ohmic

Figure 7 is a contour plot of the radial (dr) displacements due to room temperature gravity loading plus 1.7T Ohmic EM forces. The peak TF coil radial displacement is ~ 0.4 mm on the outboard leg of the TF coils near the horizontal midplane of the machine. There are also somewhat greater (0.7mm) radially inboard displacements at the tops of the two A-A joint columns as indicated by the dark blue contours, and an outboard radial displacement, due to the bending, at the lateral brace connections (see the insert depicting the exaggerated view of this from the reverse side of the column in figure 7).

```

ANSYS 11.0SP1
SEP 24 2008
11:07:28
NCSX-TP-PF-STRUCT-304g5h-all4b
NODAL SOLUTION
STEP=1
SUB =1
TIME=1
UX      (AVG)
RSYS=1
PowerGraphics
EFACET=1
AVRES=Mat
DMX =.005334
SMN =-.693E-03
SMX =.662E-03

```

Blue	-.693E-03
Light Blue	-.542E-03
Cyan	-.392E-03
Light Green	-.241E-03
Green	-.907E-04
Yellow-Green	.599E-04
Yellow	.210E-03
Orange	.361E-03
Red-Orange	.512E-03
Red	.662E-03

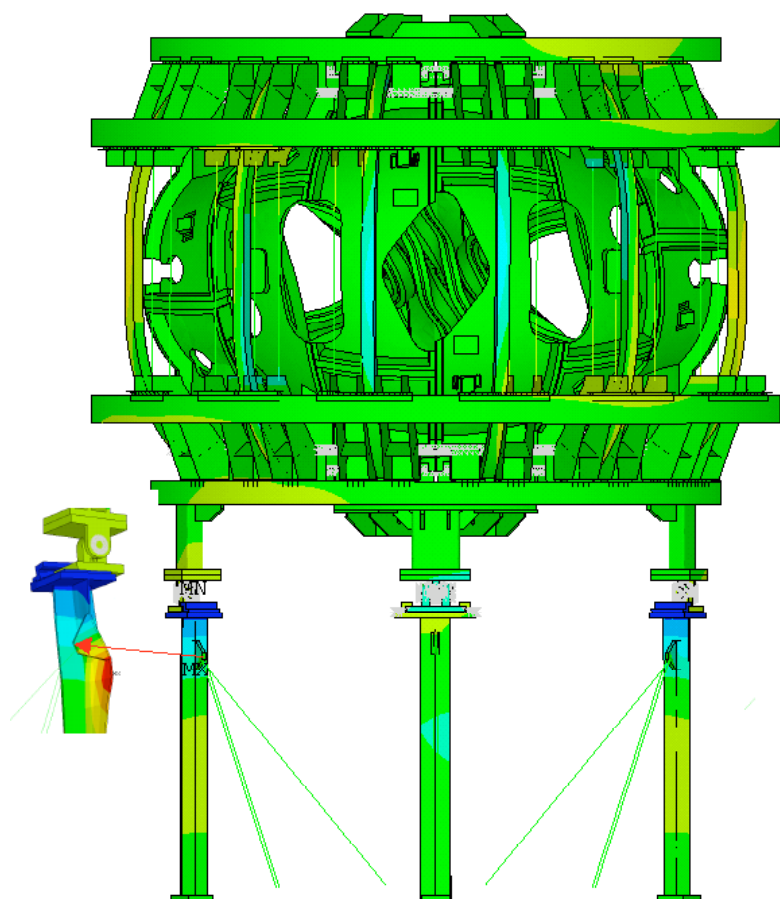

Figure 7. Radial displacement contours -stellarator core at R.T. – 1.7T Ohmic

Figure 8 is a contour plot of the circumferential ($d\theta$) displacements due to room temperature gravity loading plus 1.7T Ohmic EM forces. The maximum circumferential displacement is 5.31mm, also on the outboard leg of the TF coils near the horizontal midplane of the machine.

```

SEP 24 2008
11:08:51
NCSX-TP-PF-STRUCT-304g5h-all.
NODAL SOLUTION
STEP=1
SUB =1
TIME=1
UY      (AVG)
RSYS=1
PowerGraphics
EFACET=1
AVRES=Mat
DMX =.005334
SMN =-.005314
SMX =.005143

```

Blue	-.005314
Light Blue	-.004152
Cyan	-.00299
Light Green	-.001828
Green	-.666E-03
Yellow-Green	.495E-03
Yellow	.001657
Orange	.002819
Red-Orange	.003981
Red	.005143

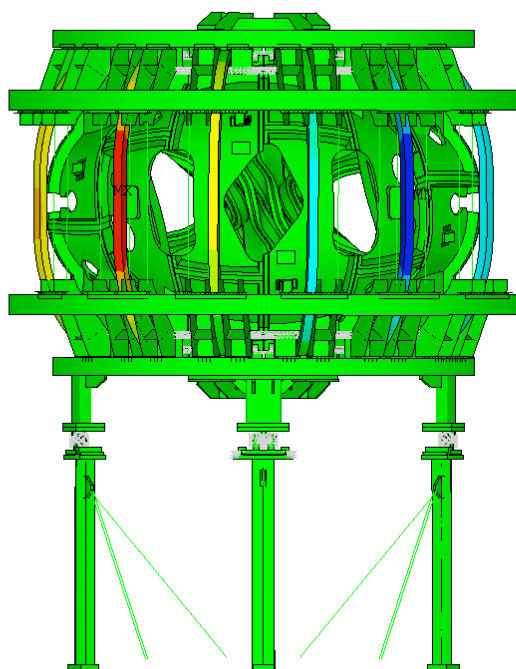

Figure 8. Circumferential displacement contours -stellarator core at R.T. – 1.7T Ohmic

The Tresca stress contours are plotted for the room temperature gravity plus 1.7T Ohmic-EM loading in Figure 9a and indicate a peak stress of 205 MPa (29.7 ksi) at the lower edge of the bracket connecting the inboard lateral bracing. This peak bending stress in the lateral connecting bracket is seen to be at the weld ends in figure 9b. This exceeds the fillet weld allowable and will require some additional reinforcement and/or local modeling refinement.

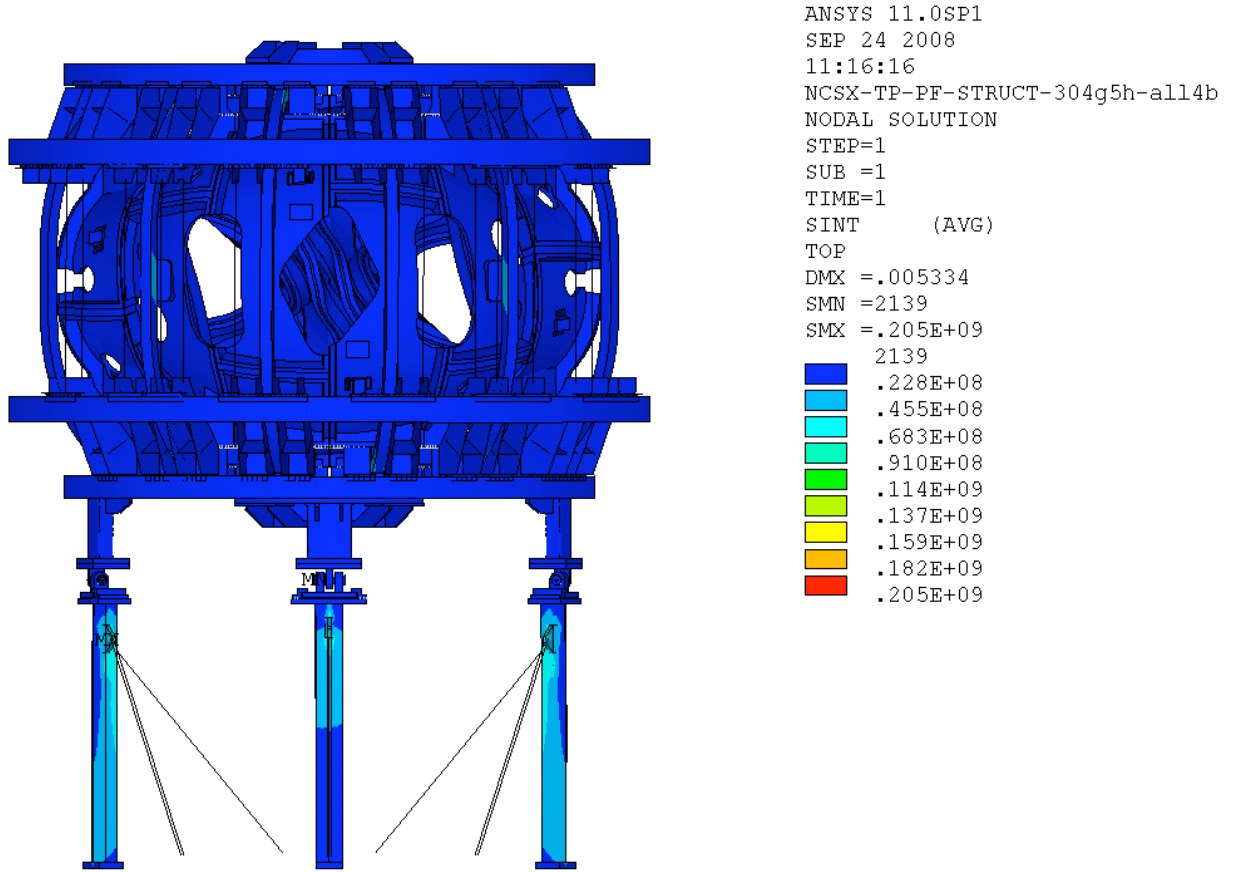

Figure 9a. Tresca stress contours -stellarator core at R.T. – 1.7T Ohmic -peak stress is 29.7 ksi

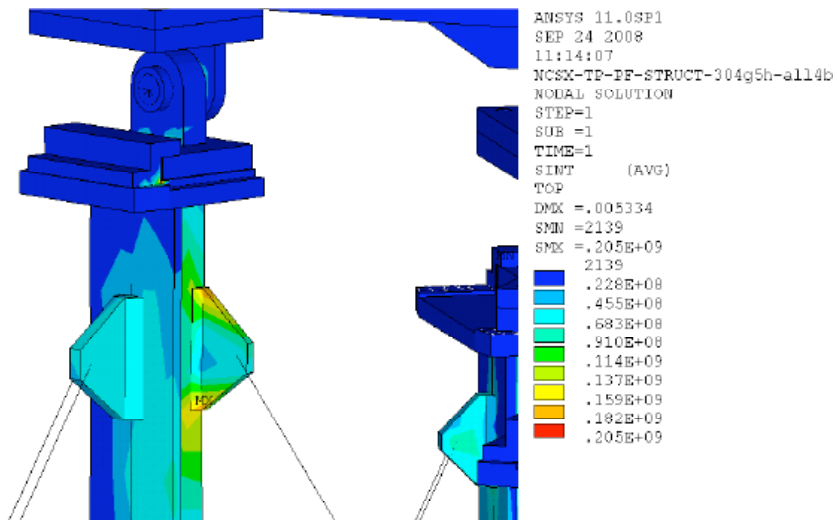

Figure 9b Peak Tresca stress contours at R.T. - 1.7T Ohmic -peak stress is 29.7 ksi

Figure 10 below is a contour plot of the TF coil Tresca stresses and indicates a peak stress of 63 MPa (9.1 ksi) at the outer coil clamps for coils 2 & 5. The average stress on the outer legs of these coils is ~ 25 MPa.

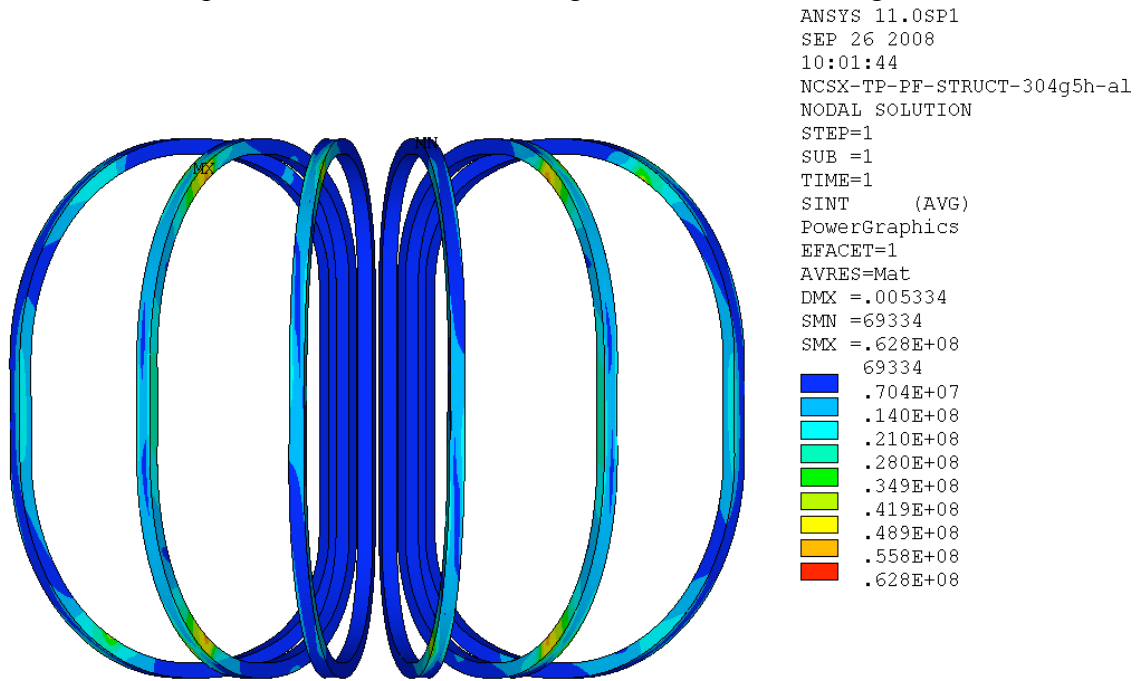

Figure 10 Peak TF Coil Tresca stress contours at R.T. - 1.7T Ohmic -peak stress is 9.1 ksi

Figure 11 below is a contour plot of the PF coil Tresca stresses and indicates a peak stress of 8.1 MPa (1.18 ksi) at the inner radial edge of the coil clamps for PF5.

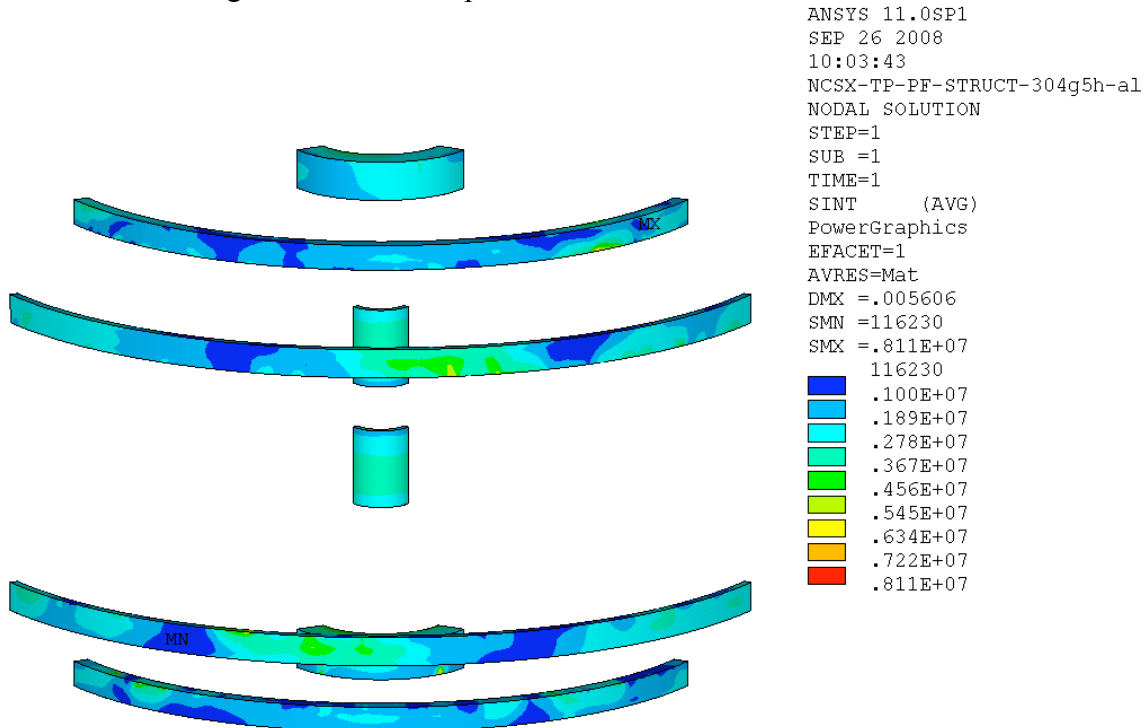

Figure 11 Peak PF Coil Tresca stress contours at R.T. - 1.7T Ohmic -peak stress is 1.18 ksi

Load Case 2: 46.87 kip Inboard, & 53.13 kip Outboard Support Cooldown Loading

When the stellarator core is cooled down to 77 K there is a small redistribution of loads which increases the gravity loading on the outboard column supports by about 3 kips and reduces the inboard column load by the same amount. When the core is cold the outboard supports now have a total gravity loading of 53 kip per support and the inboard columns have a 47 kip load. Additionally, due to the differential thermal contraction between the stainless structure and the copper-epoxy-glass coil composites, thermal stresses are also induced when the cold mass is at 77 K..

Load Case 2 added the cooldown loading in addition to the gravity and 1.7T Ohmic EM loads. Figures 12 thru 15 show the displacement contours with the peak displacement of 12mm at the outer leg of the TF coils. As can be seen in figure 12, this is predominantly an inboard radial displacement due to thermal contraction.

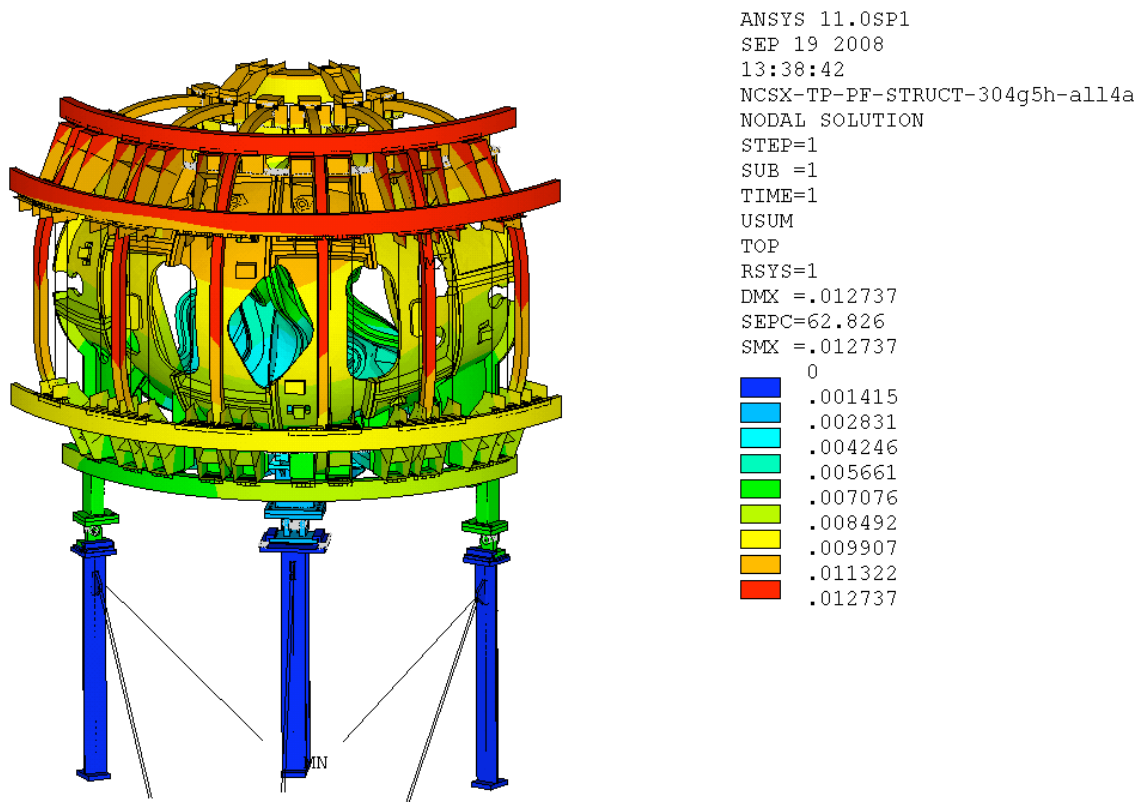
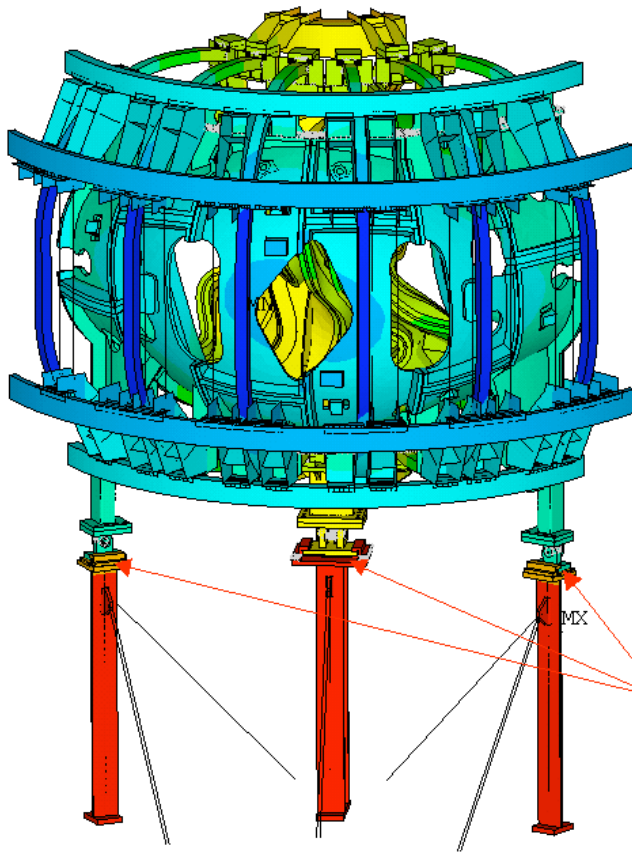

Figure 12. SRSS Displacements due to 1.1g + EM + core at 77 K – 1.7T Ohmic

Figures 13 and 14 below show the radial and circumferential displacements due to cooldown, EM, and gravity loading. The peak radial displacements of 10 mm as seen in figure 13, occurs at the outer legs of the TF coils. The minimum radial displacement of 0 mm is at the fixed boundary conditions at the column bases with a slight radially inboard tilt at the tops of the columns due to the frictional loads applied there. The radial displacements of the two outboard (located at the C-C joint) sliding interfaces is about -5 mm while the inboard support slides about -2 mm. The circumferential displacement peaks occur at the outboard legs of the TF coils 2 & 5 and are ± 5 mm which is nearly identical with the room temperature deflections. This indicates that the EM forces are the predominant contributor to the circumferential displacements of the TF coils. The rest of the coils and structure show little if any circumferential movement.



```

ANSYS 11.0SP1
SEP 19 2008
13:40:16
NCSX-TP-PF-STRUCT-304g5h-all4a
NODAL SOLUTION
STEP=1
SUB =1
TIME=1
UX
TOP
RSYS=1
DMX =.012737
SEPC=62.826
SMN =-.010075
SMX =.672E-03

```

Blue	-.010075
Dark Blue	-.00888
Light Blue	-.007686
Cyan	-.006492
Green	-.005298
Light Green	-.004104
Yellow-Green	-.00291
Yellow	-.001716
Orange	-.522E-03
Red	.672E-03

Relative radial sliding occurs at these low friction surfaces

Figure 13. Radial Displacements due to 1.1g + EM + core at 77 K – 1.7T Ohmic

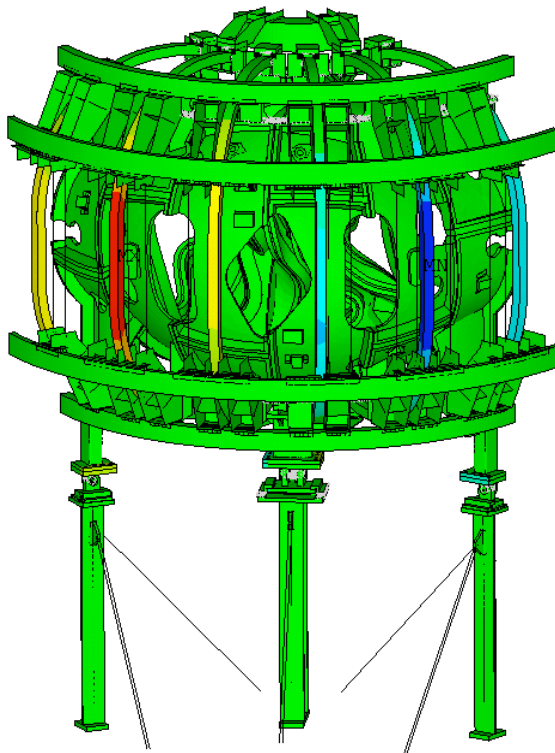

```

ANSYS 11.0SP1
SEP 19 2008
13:42:12
NCSX-TP-PF-STRUCT-304g5h-all4a
NODAL SOLUTION
STEP=1
SUB =1
TIME=1
UY
TOP
RSYS=1
DMX =.012737
SEPC=62.826
SMN =-.005135
SMX =.005043

```

Blue	-.005135
Dark Blue	-.004004
Light Blue	-.002873
Cyan	-.001742
Green	-.611E-03
Light Green	.520E-03
Yellow-Green	.001651
Yellow	.002781
Orange	.003912
Red	.005043

Figure 14. Circumferential Displacements due to 1.1g + EM + core at 77 K – 1.7T Ohmic

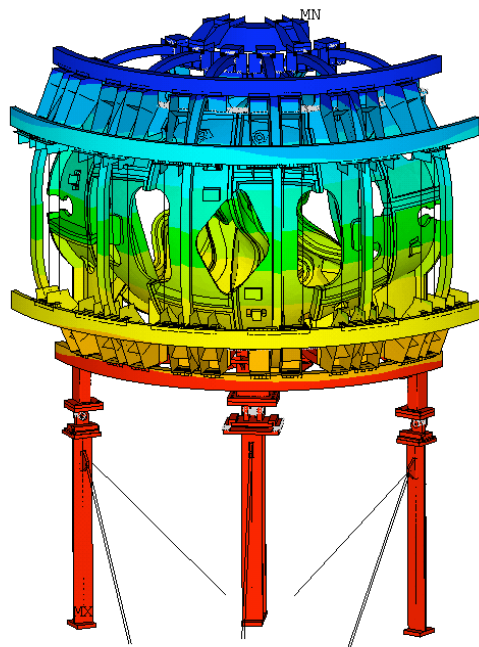

```

ANSYS 11.0SP1
SEP 19 2008
13:43:47
NCSX-TP-PF-STRUCT-304g5h-all4a
NODAL SOLUTION
STEP=1
SUB =1
TIME=1
UZ
TOP
RSYS=1
DMX =.012737
SEPC=62.826
SMN =-.010193
SMX =.363E-06
-.010193
-.00906
-.007928
-.006795
-.005662
-.00453
-.003397
-.002265
-.001132
.363E-06

```

Figure 15. Vertical Displacements due to 1.1g + EM + core at 77 K – 1.7T Ohmic

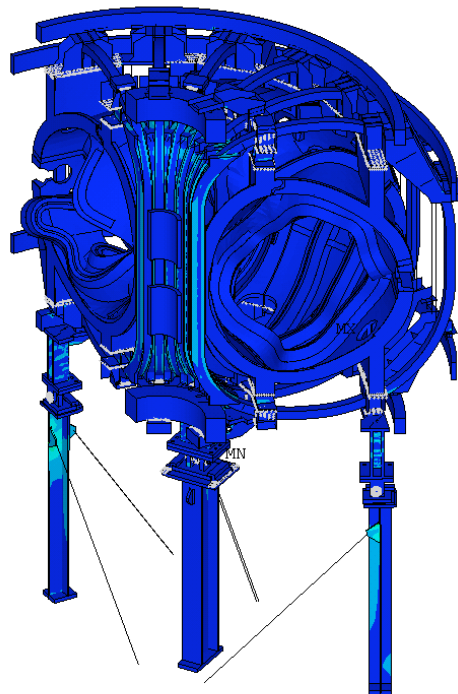

```

ANSYS 11.0SP1
SEP 19 2008
13:31:47
NCSX-TP-PF-STRUCT-304g5h-all4a
NODAL SOLUTION
STEP=1
SUB =1
TIME=1
SINT (AVG)
TOP
DMX =.012737
SMN =1982
SMX =.340E+09
SMXB=.539E+09
1982
.377E+08
.755E+08
.113E+09
.151E+09
.189E+09
.226E+09
.264E+09
.302E+09
.340E+09

```

Figure 16. Tresca stress contours – due to 1.1g + EM + core at 77 K – 1.7T Ohmic

The vertical displacement contours for load case 2 are shown in figure 15 above. The maximum downward displacement is -10 mm at the top of the machine and is due primarily to thermal contraction with a minor contribution (10% to 20%) from the gravity loading. The base support structure and lower interface structure are seen to displace less than 1 mm.

Figure 16 shows the Tresca stress contours due to load case 2. The peak Tresca stress is seen to be 340 MPa (see figure 17 below) and occurs at the corner edges of the cantilevered brackets attaching the 2nd and 5th lower outboard TF support brackets to the MCWF shell. These cantilevers span the gap between adjacent shelf segments of the MCWF casting, with the attachment modeled by coupling grid points at these discrete locations producing a somewhat synthetic stress concentration at these locations. The actual

load transfer will be through a bolted connection which should distribute the load more uniformly and alleviate these stress concentrations.

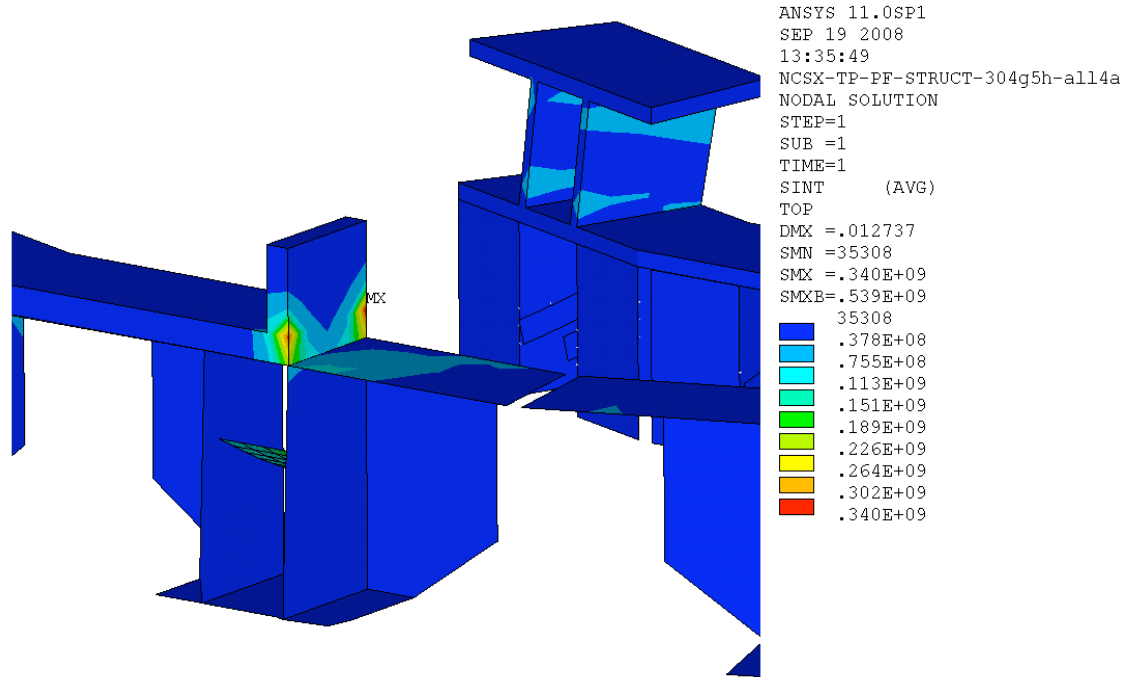

Figure 17. PeakTresca stress contours TF Bracket- 1.1g + EM + core at 77 K – 1.7T Ohmic

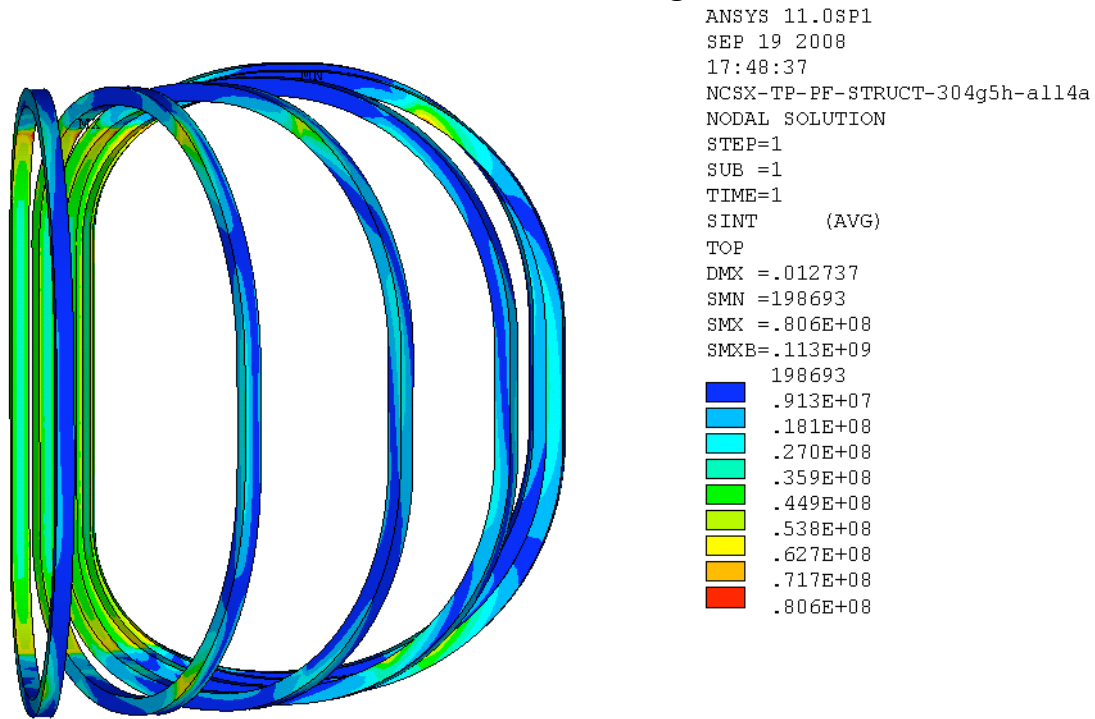

Figure 18. Tresca stress contours for the TF Coil - 1.1g + EM + core at 77 K – 1.7T Ohmic

Figure 18 shows the peak Tresca stress contours in the TF coils for load case 2. The peaks of 80.6 MPa (11.7 ksi) occur at the transition near the start of the coil wedge castings on the upper and lower inboard legs. This result agrees well with an earlier analysis of the TF coil which modeled the coil in more detail using discrete turns and insulation layers in this local region of the coil.

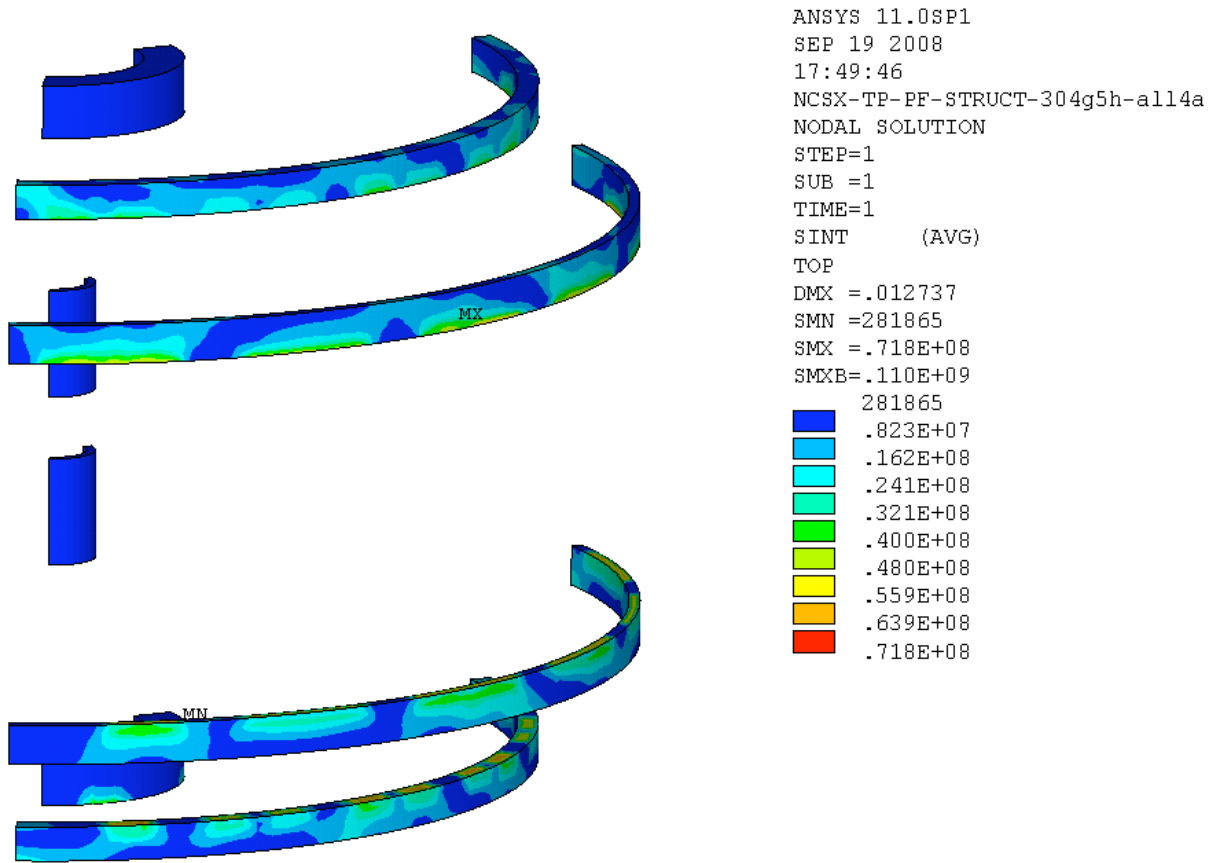

Figure 19. Tresca stress contours for the PF Coil - 1.1g + EM + core at 77 K – 1.7T Ohmic

Figure 19 show the Tresca stress contours for load case 2 with the peak 7.1 MPa (1 ksi) near the zero degree clamps on PF6

Spherical Bearing & Housing:

The Spherical bearings and housing are fabricated from 718 Inconel and Monel.

The load capacities are:

- Dynamic load Limit: 117 kip
- Ult. Static load: 338 kip
- Static Load limit: 270 kip

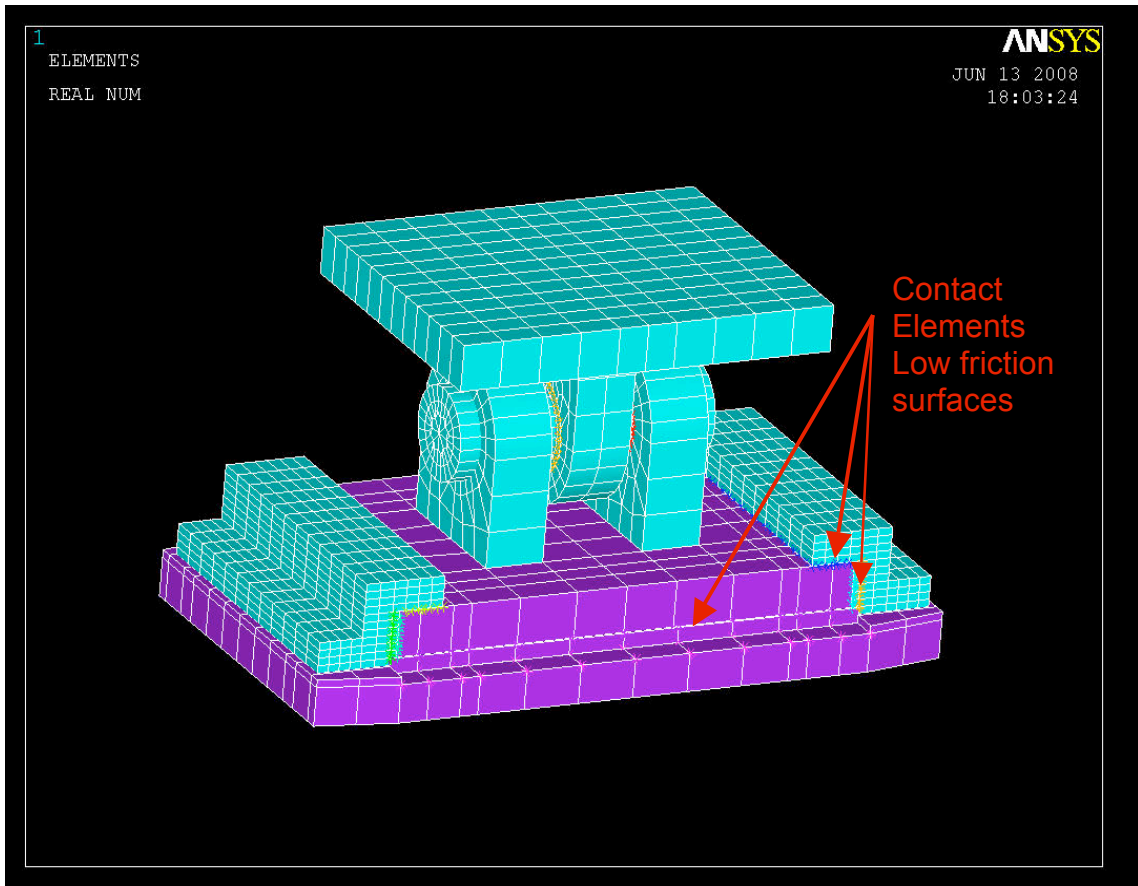
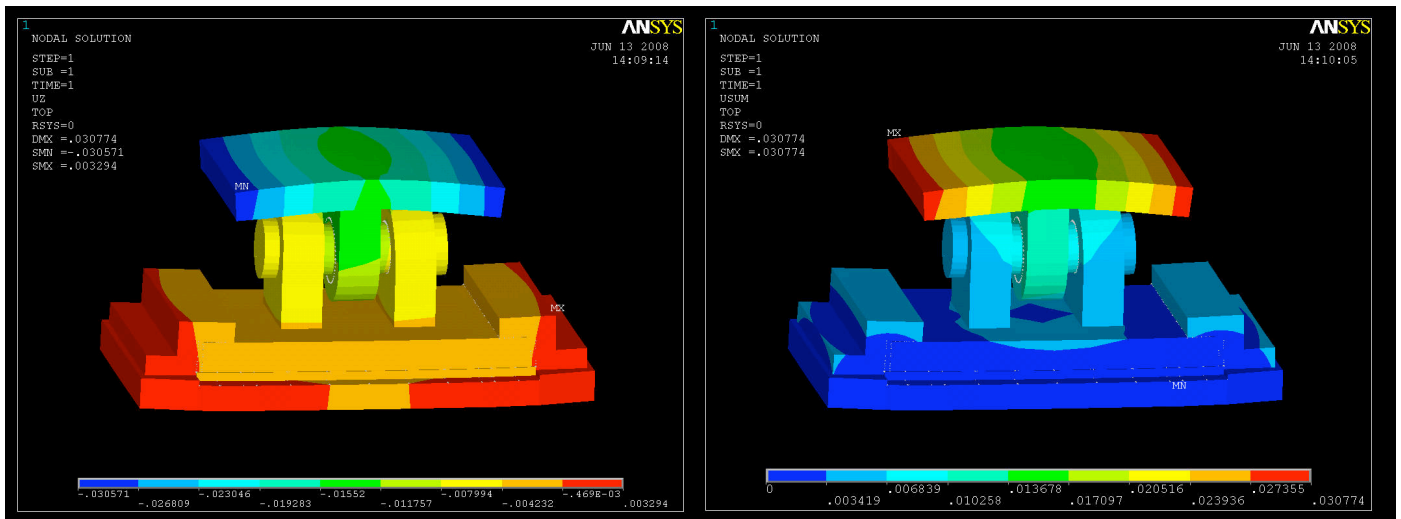

Figure 20. Coil Structure – Base Support Spherical Bearing Interface

Above in Figure 20 is a view of the detailed FEA model of the machine/base support interface which includes the spherical bearing housing. Figure 21 shows the displacement contours due to gravity loading indicating a peak vertical displacement of 0.1 mm and maximum vector sum displacement of 0.8 mm.



Maximum vertical displacement: 0.0033" @ top plate

Maximum SRSS displacement: 0.0308" @ top plate

Figure 21. Displacements for 100 kip gravity loading on the outboard columns

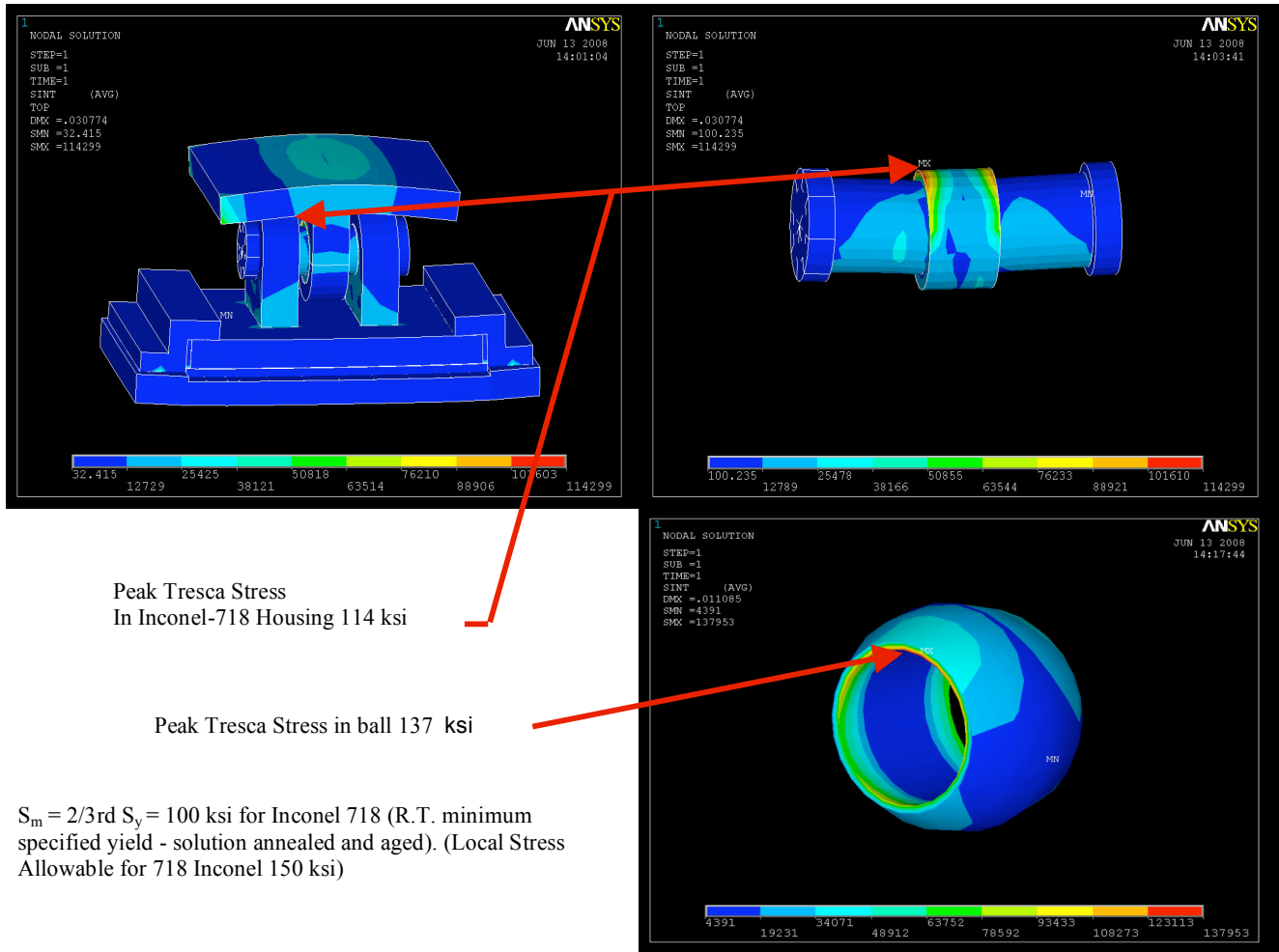

Figure 22. Tresca stress contours in the spherical bearing and housing

TF Coil Pre-load ring:

The detailed FEA model of the TF coil preload ring is shown in figure 23a below. The displacement contours for a 4 kip pre-ola per coil is shown in figure 23b and indicates a maximum radial displacement of 0.007” at the base where the preload is applied (greatly amplified in the figure).

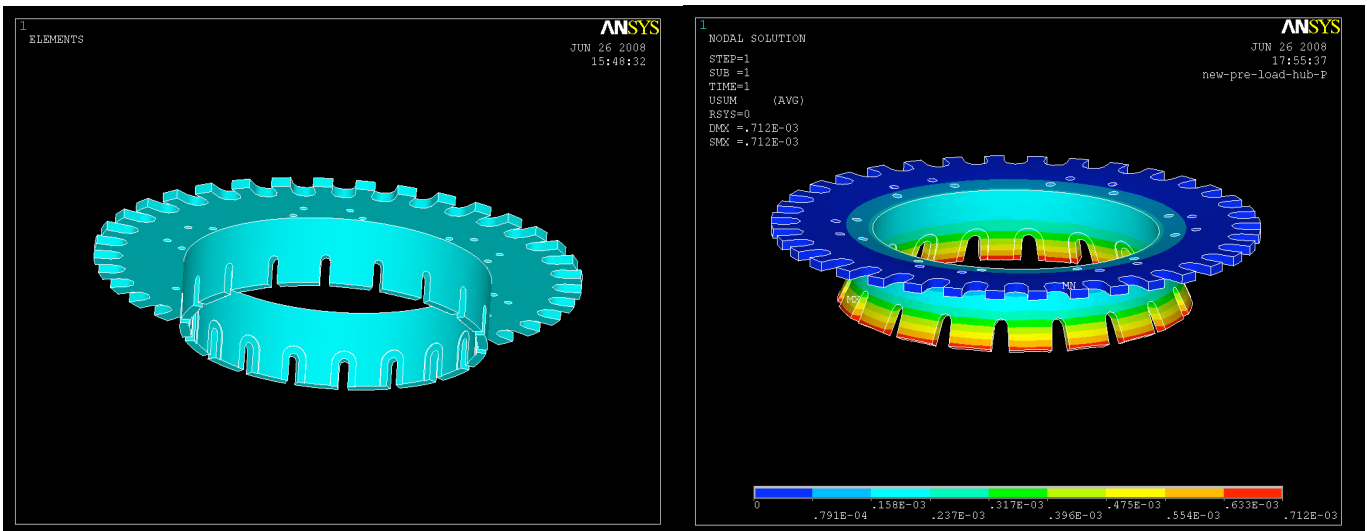
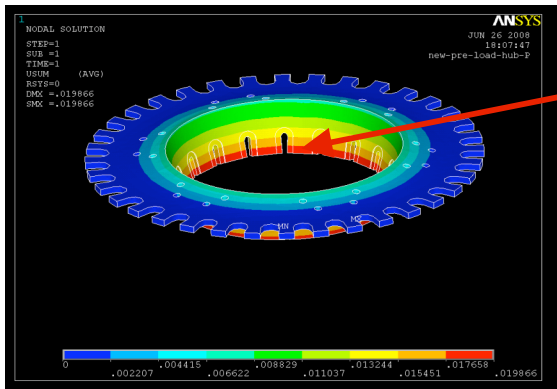

Figure 23a. TF Coil Pre-load ring FEA Model

Figure 23b. Radial displacements of Preload Ring



For a 20 deg.C differential between TF coil & Hub:
 Rel. Radial Displacement
 0.019" (B'ville washers o.k. for ~0.040").

Tresca stresses due to thermal effects are high, Peak (mostly bending) @ corner 32.8ksi (226MPa)

Thermal Differentials are the most severe loading & Stress on these structures.

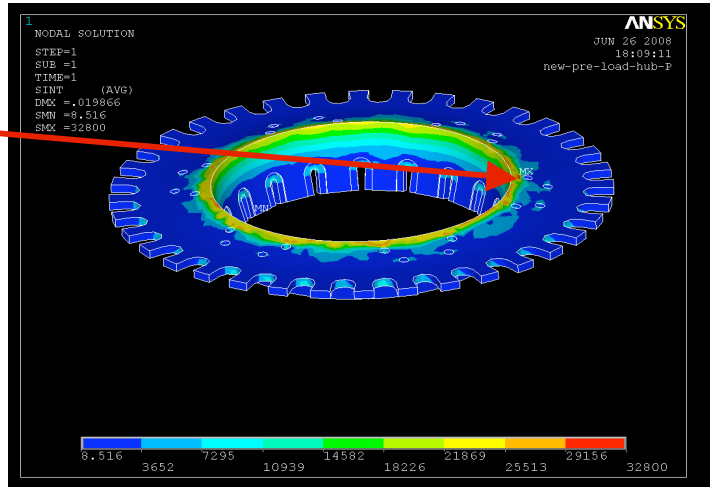
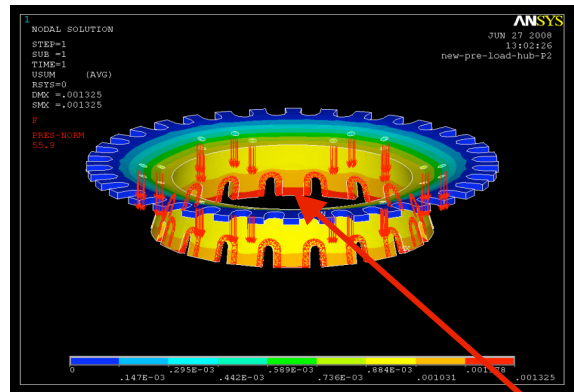
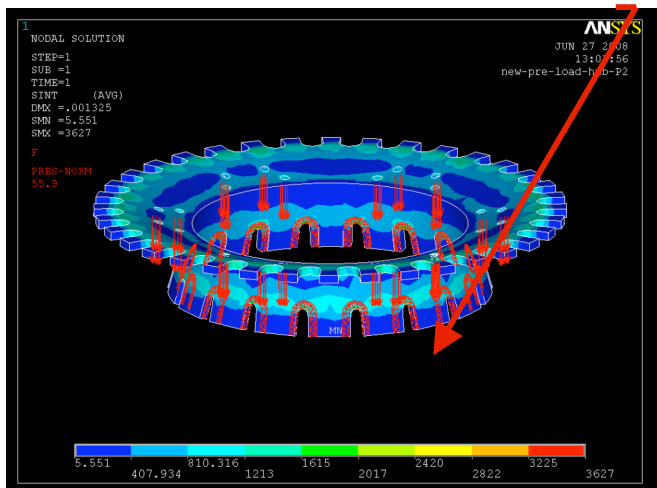

Figure 24. Thermal displacements and Tresca stress contours on the TF Coil Preload Ring

Figure 24 above shows the displacements and Tresca stress contours that develop in the TF Coil preload ring from a 20 degree C temperature differential between the TF coil and the ring. The peak bending stress of 32.8 ksi occurs at the inner edge of the ring.

Appendix V contains a computer listing for a fault loading condition where one of the two PF1a coils in the C.S. is shorted out and a 4.4 kip vertical launching load is applied to the TF Coil preload ring where it attaches to the PF1a structure. Figure 25 below shows the results of this fault load.

Results for 1 coil out fault loading - a 4.4 kip launch loading.



Total SRSS Displacement: 0.0013"

Stress & Deflections from C.S. fault conditions are well within allowables

Note: modeled in lbs & inches

Figure 25. Stress and Displacement contours for a 4.4 kip vertical launch load from the C.S.

Load Case 3: Seismic Loading with 46.87 kip Inboard, & 53.13 kip Outboard Support:

The seismic loading considered is based on the NCSX Seismic Design Criteria (NCSX-CRIT-SEIS-00), which requires a 0.171 g static load applied at the machine core c.g. per Table I. A modal analysis predicts the primary flexible mode will be @ 1.7 Hz as a lateral flex at 30 degrees off the X-axis.

Simplified for the Test Cell:

$$F_p = S_c \cdot I_p \cdot W_p$$

Where Seismic Coefficient S_c Equals:

	Low Deformability $R_p=1.25$	Limited Deformability $R_p=2.5$
Rigid Structures $a_p = 1$ ($F_n=16.7$ hz)	.114	.072 (Calculated=.057 but reverts to min. value)
Non Rigid Structures $a_p = 1.5$ ($F_n < 16.7$ hz)	.171	.085

TABLE I (REF. NCSX-CRIT-SEIS-00)

This translates into a static horizontal load of 51,300 lbs applied at a height of 15.2 feet above the test cell floor. For the preliminary model of the machine core, six semi-rigid beams were added to the base support structure model to represent the approximate stiffness of the core. The beam elements extended from 4” above the support column pedestals to the machine c.g. located 15.2 feet above the floor at the machine center. The preliminary seismic analysis was performed using only the base support structure and these semi-rigid connections to a lumped mass representing the machine core. The results of that analysis are reported in the NCSX-CALC-17-001-00 DAC.

To apply the seismic loads in the current global model a static horizontal 0.171g x 1.1 acceleration was applied at 30 degrees in addition to the 1.1g vertical gravity acceleration. Since the simultaneous occurrence of a seismic event during a machine pulse was of extremely low probability, no EM loads were included in these seismic loading conditions. The displacement contours of this seismic loading are shown below in figure 26. It should be noted that the cooldown displacements predominate, with seismic lateral displacements contributing less than 10% to these results. The maximum radial displacement is 1 mm while the maximum vertical displacement is 10 mm.

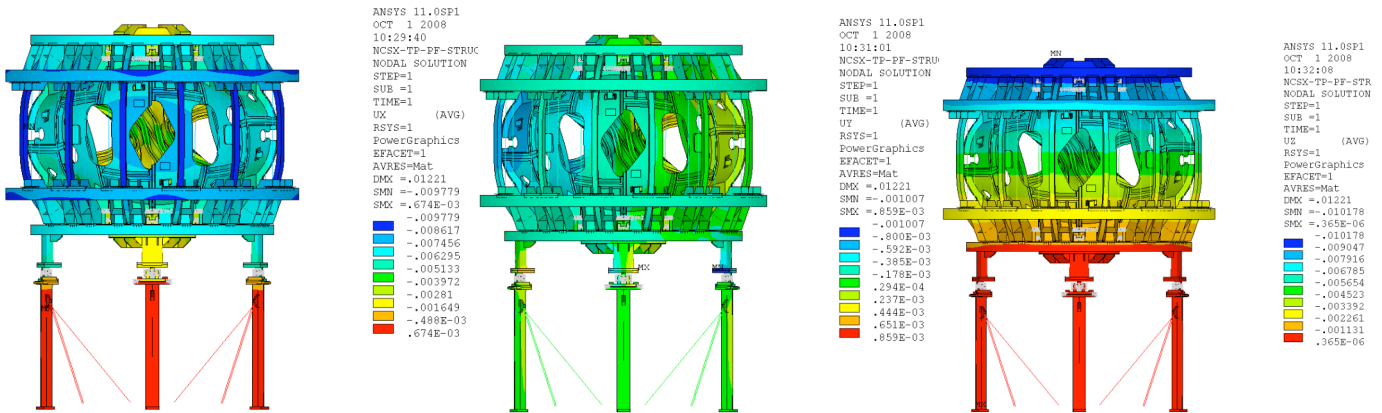

Radial Displacements – Seismic + cooldown Theta Displacements – Seismic + cooldown Vertical Displacements – Seismic + cooldown

Figure 26. Displacements due to Seismic loading at 77 degrees K

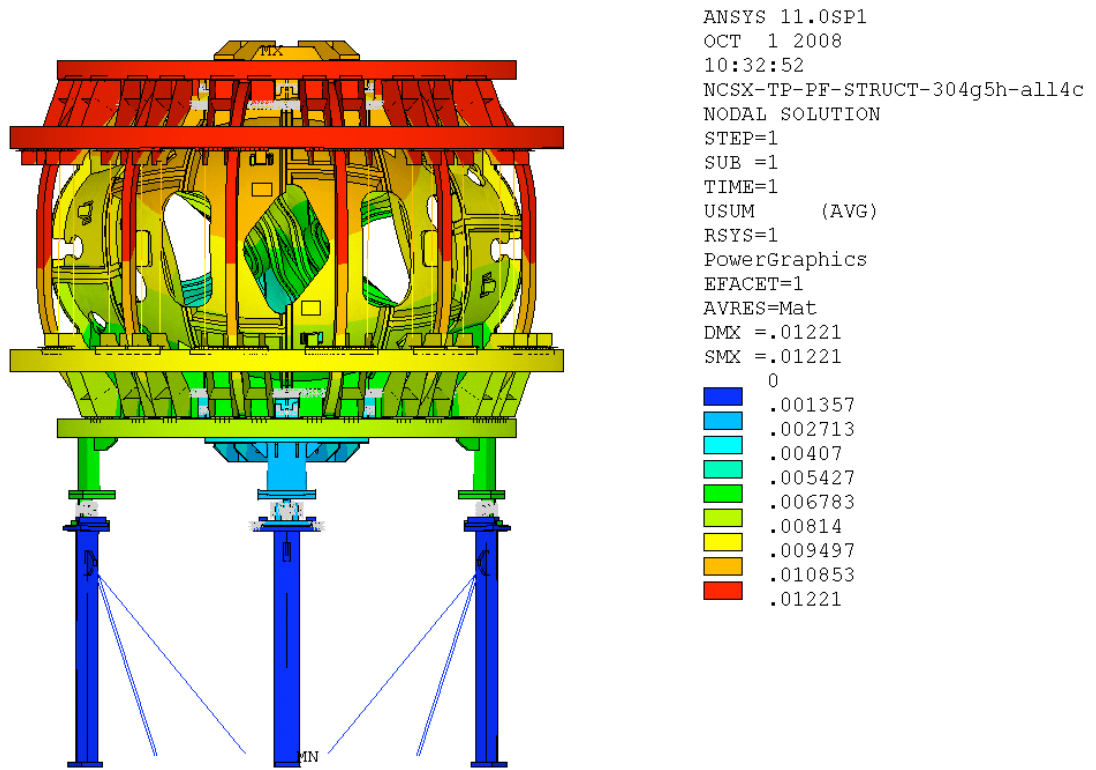

Figure 27. SRSS (vector sum) displacement for seismic loading at 77 deg.K

Figure 27 is the vector sum displacement contours and indicates a peak of 12.2 mm at the upper PF6 coil. Comparing these displacements with the result shown in figure 12 (SRSS displacements for EM at 77K) indicates that the contribution from the seismic acceleration is somewhat less than 0.5 mm when the EM displacement effects are accounted for. Figure 28 below shows the Tresca stress contours for this load case indicating a peak of 331 MPa, slightly less than the 340 MPa for the EM + cooldown stress in Figure 17.

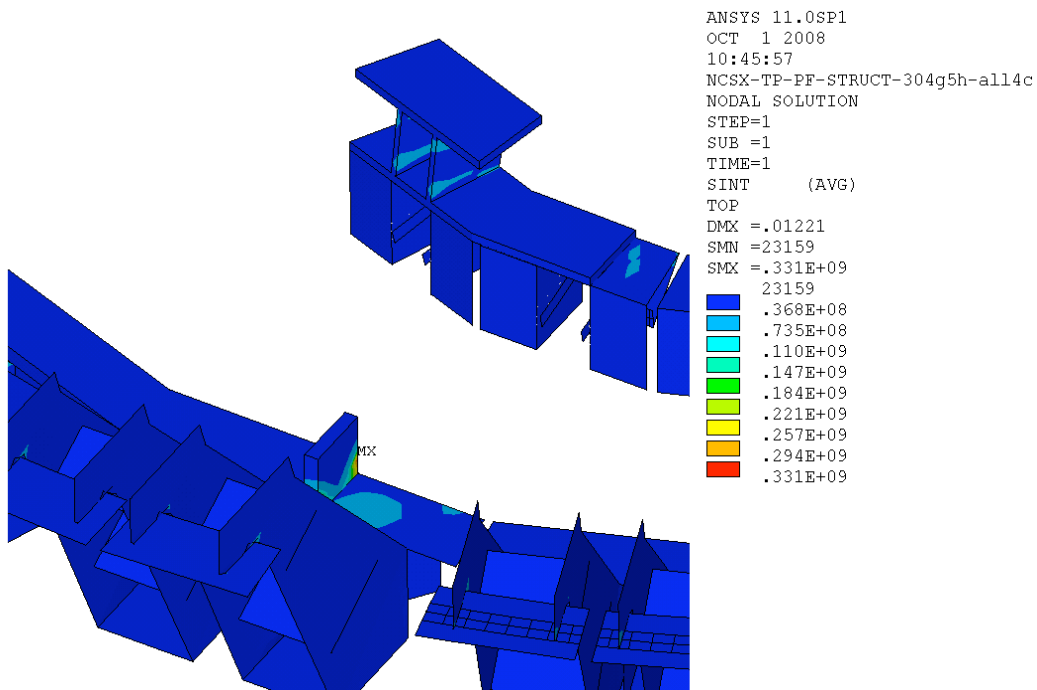

Figure 28. Tresca stress contours for seismic loading at 77 deg. K

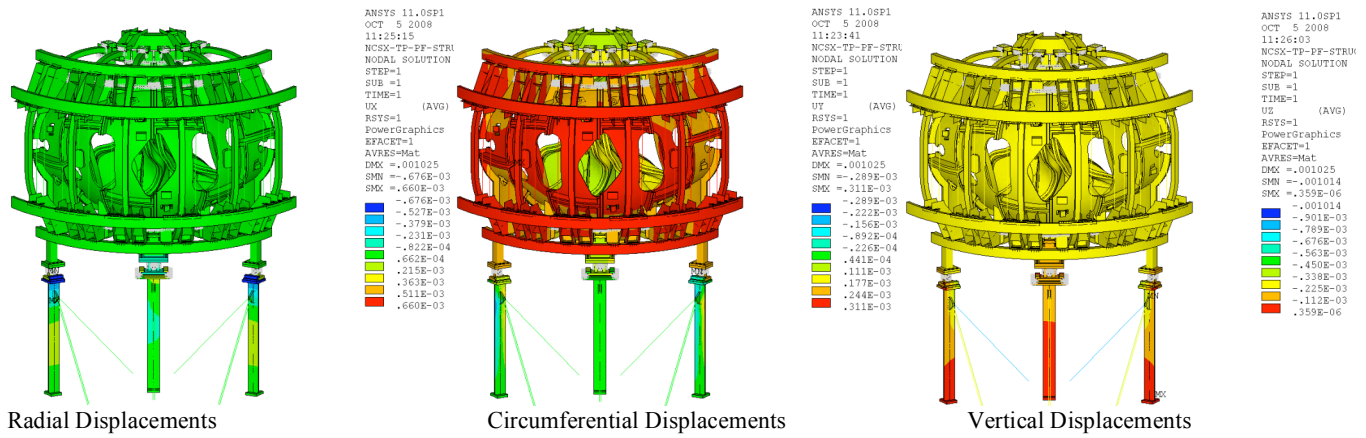

Figure 29. Displacements due to Seismic loading at room temperature

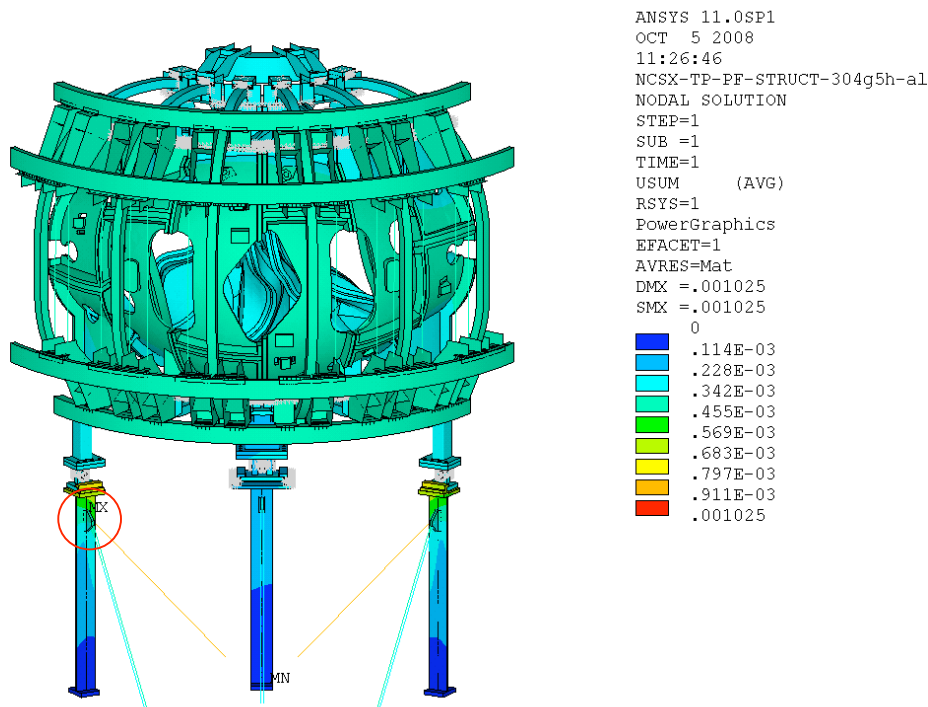

Figure 30. SRSS (vector sum) displacement for seismic loading at room temperature

Figure 29 & 30 above show the displacement contours for the machine at room temperature under a $0.171 \text{ g} \times 1.1$ horizontal static load at 30 degrees azimuthally from the zero degree (A-A joint plane), and a 1.1 g vertical loading. This represents the MIE seismic loading as defined in the GRD (the 1.1 multiplier is used to account for any supplemental component mass not included in the model). The 30 degree direction corresponds to the peak motion direction of the lowest flexible mode of a prior modal analysis. Since the 77 K results shown in figures 26 to 29 include the predominant cooldown effects the results for the room temperature run is a more accurate representation of the seismic effects on the structure. As can be seen in the figures, the seismic loading produces displacements of 1 mm or less. The peak SRSS displacement of 1 mm occurs at the welded brackets to which the lateral braces of the base supports are attach (circled in red in figure 30).

The Tresca stress contours for the room temperature seismic run are shown in figure 31 below. The peak stress is seen to be 29.4 ksi (203 MPa) which is highly localized at the weld root of the lateral brace bracket (see the insert in figure 31).

ANSYS 11.0SP1
OCT 5 2008
11:31:44
NCSX-TP-PF-STRUCT-304g5h-a1
NODAL SOLUTION
STEP=1
SUB =1
TIME=1
SINT (AVG)
TOP
DMX =.001025
SMN =429.631
SMX =.203E+09
429.631
.226E+08
.452E+08
.678E+08
.904E+08
.113E+09
.136E+09
.158E+09
.181E+09
.203E+09

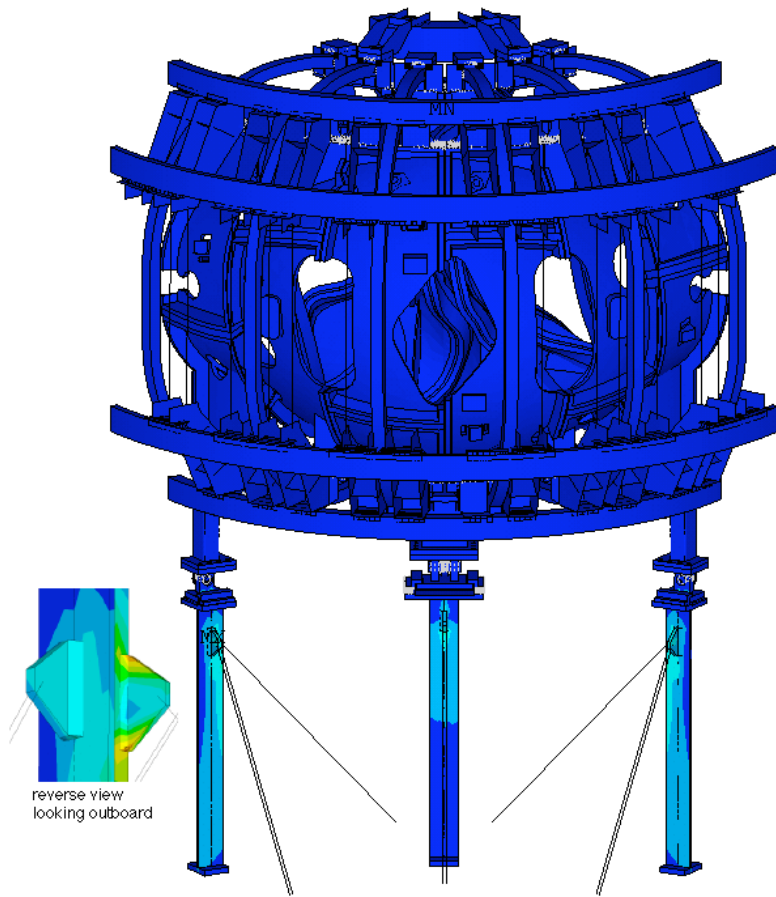
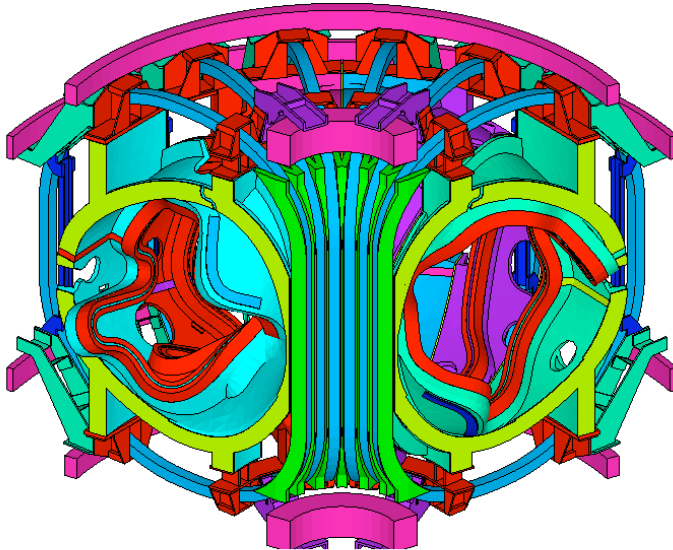

Figure 31. Tresca stress contours for seismic loading at room temperature

Global model – H.M. Fan:

Figure 32 below shows the global FEA model by H.M. Fan which included loading from the trim coils and analyzed the 2T HiBeta EM loading (which was determined to be the worst case loading for the MCWF). The results of several loading conditions, including flexibility cases (iota019 & iota065), were run and are summarized in Appendix I & Ia.



HM Fan FEA model Runs the 2T HiBeta load case -includes trim coil loading.

Positive & negative polarity trim coil loading conditions were analyzed.

EM, gravity, and cooldown loading conditions were analyzed separately and as combined load cases

Cyclically symmetric boundary conditions with elastic vertical & circumferential constraints at the A-A and C-C joints to eliminate RBMs.

Figure 32. Global FEA model (H.M. Fan)

The model consists of solid Hexahedral and Tetrahedral elements with bonded contact elements defining the component interfaces. The interface with the base support structure is represented with elastic (spring) elements with one end fixed to ground and with a stiffness representative of the bending, axial, and torsional stiffness of the base support structural elements. There are cyclically symmetric boundary conditions at the ± 60 degree planes which simulate the full 360 degree machine structure.

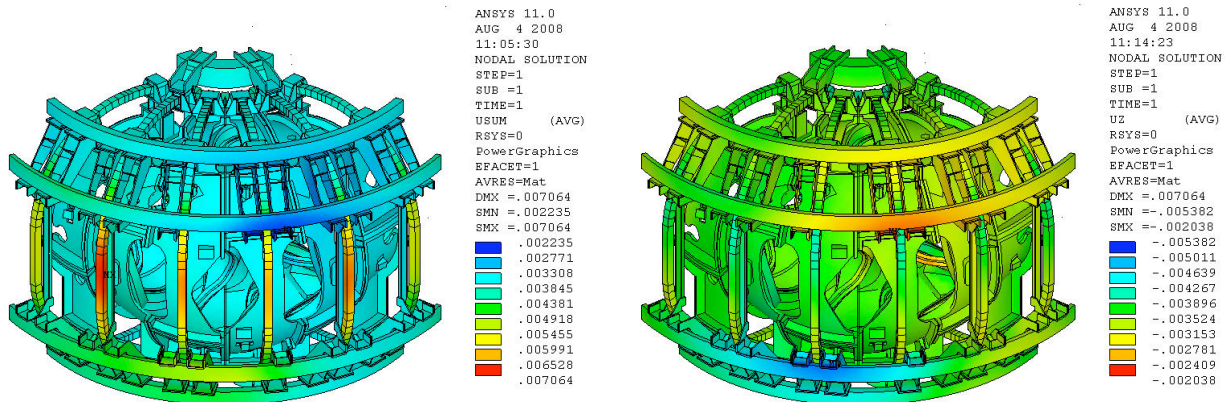

Peak SRSS Displacements: 7mm

Peak Vertical Displacements: -5.4mm

Figure 33. H.M. Fan FEA Model Results: Displacements

The results for the 2T HiBeta at 0.197 sec. are shown in figures 33 and 34. The displacement contours in figure 33 indicate a peak SRSS displacement of 7 mm on the outer legs of TF coils 2 & 5 while the peak vertical displacement is -5.4 mm at PF6.

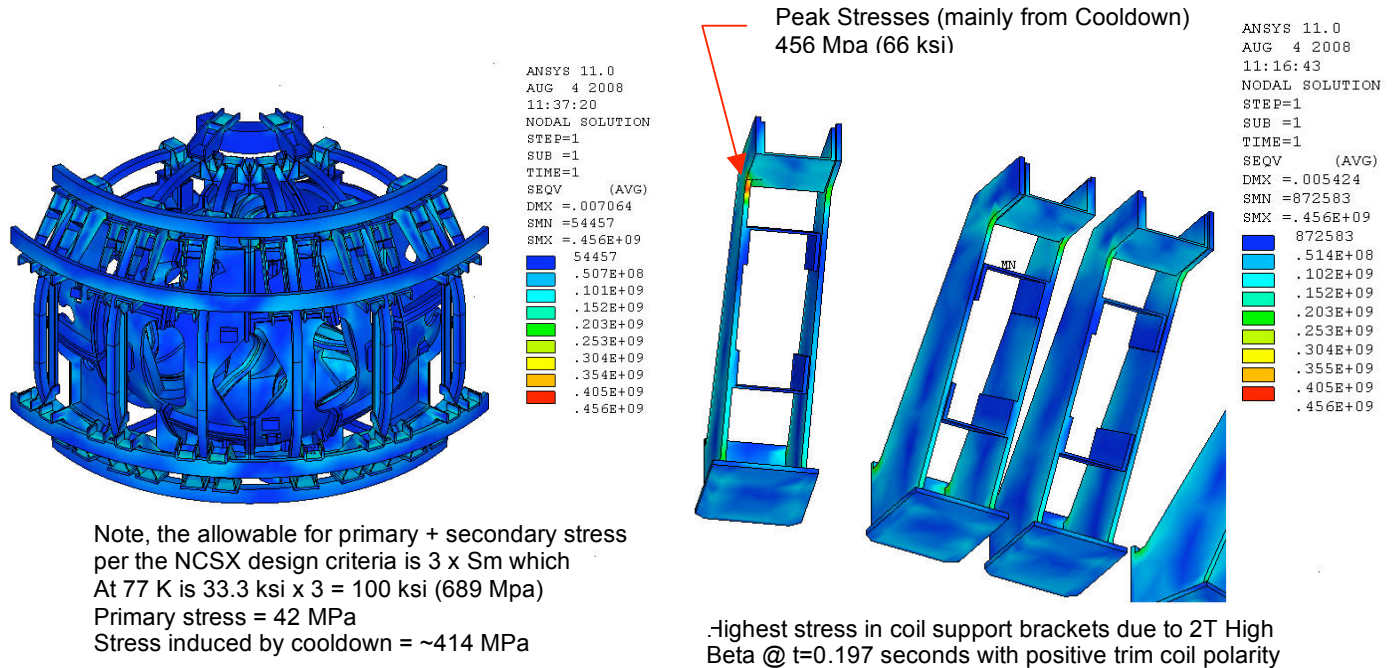

Figure 34. H.M. Fan FEA Model Results: VonMises Stress Contours

The VonMises stress contours plotted in figure 34 show a peak stress of 66 ksi (456 MPa) highly localized at the PF6 support bracket corners. The primary stress in this area is about 6.1 ksi (42 MPa) while the thermally induced component of stress is about 60 ksi (414 MPa). As noted in the figure these fall well below the primary stress allowable and the primary plus secondary allowable (which is 689 MPa).

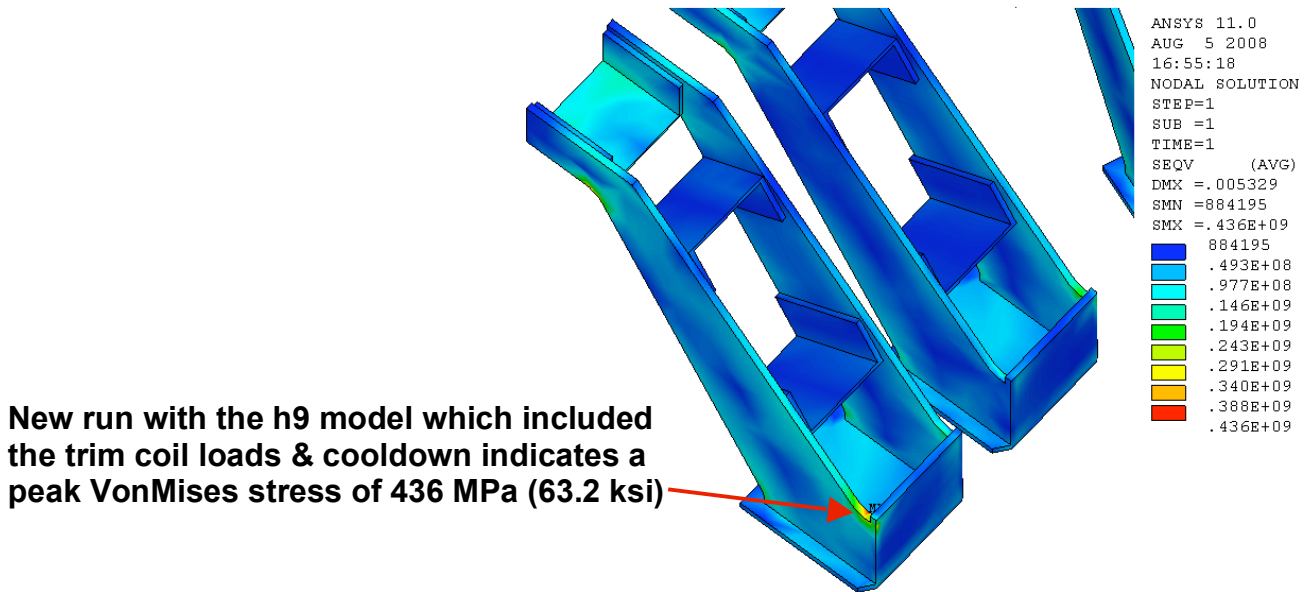

Figure 35. H.M. Fan FEA h9-Model Results: VonMises Stress Contours

A more recent run result, illustrated in figure 35, shows the peak VonMises stress shifted closer to the mounting flange on the PF6 coil support brackets. The stress for this loading, which includes trim coil forces (model h9 –see Appendix Ia for a summary of results), is reduced slightly to 63.2 ksi (436 MPa).

Fatigue:

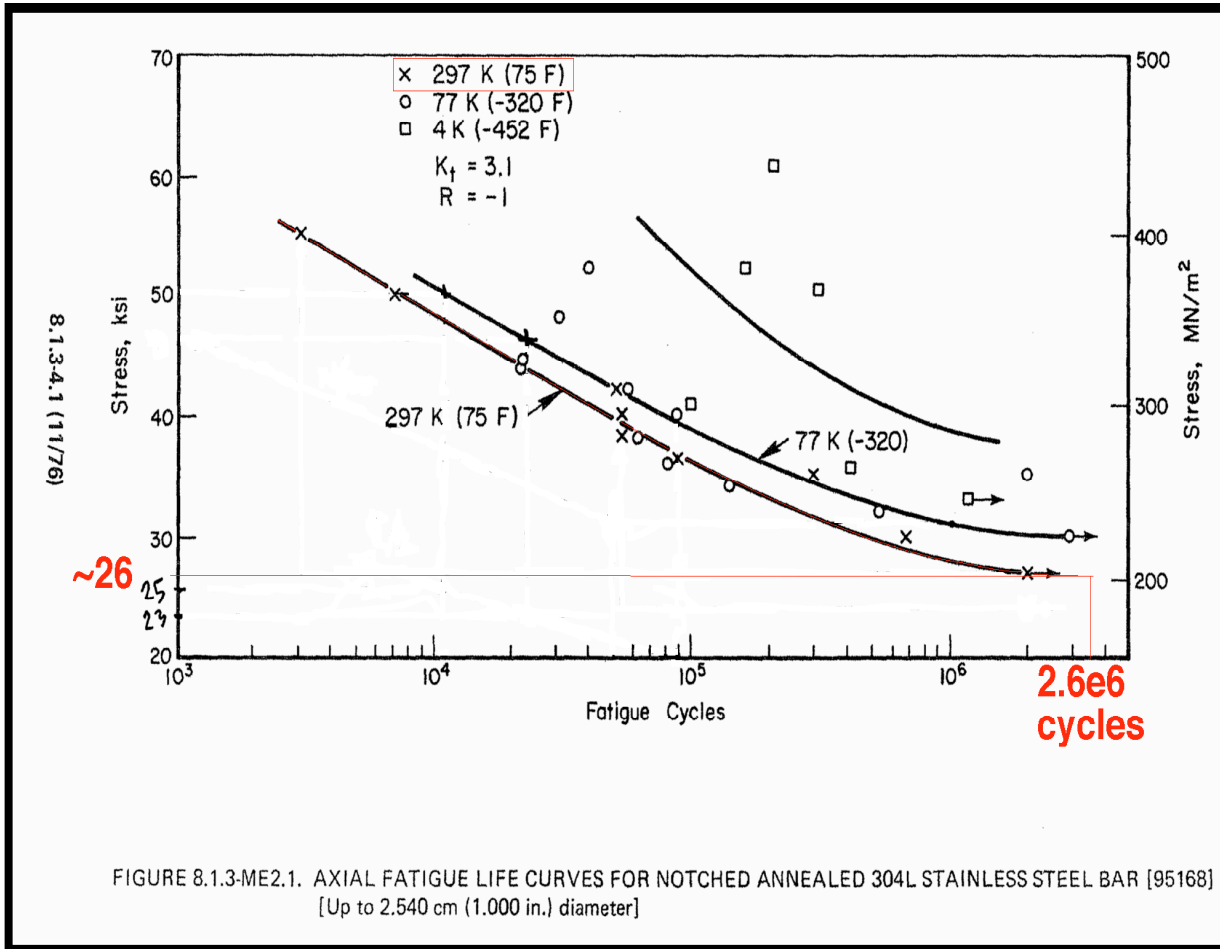

Figure 36. Fatigue Life curves for 304L stainless at R.T., 77 K, and 4 K

Conclusions:

The coil support structures meet the design allowables (S_m) for the NCSX project which for primary stresses is $2/3^{\text{rd}}$ the minimum yield stress of the materials at temperature. For the 304L this room temperature S_m is 16.6 ksi (110 MPa). At 77 deg.K the minimum yield for solution annealed 304L (based on 70% of the typical values given in Table III) is 50 ksi (345 MPa). Based on these values, the 77 deg.K S_m is 33.3 ksi (230 MPa). The peak stress intensity for the 1.7T HiBeta EM loading at 77 deg.K was 49.3 ksi (340 MPa), which is well below the $3 \times S_m$ allowable limit for a secondary local bending stresses (again this peak is mostly due to an artifact of the FEA nodal coupling). Under seismic loading conditions the peak stress intensity at 77 K is 47.8 ksi (330 MPa) occurring at the same TF bracket support extension to MCWF interface. At room temperature, the peak Tresca stress intensity of 29.4 ksi occurs in a localized section at the end weld root of a lateral bracing bracket and may merit some further model refinement there to establish the true stress in that area. Some local yielding at the weld end might be anticipated in a MIE seismic event at room temperature but should not challenge the structural integrity of the base support structure. In general the coil support stresses due to seismic loading are well below the design allowable ($1.5 S_m = 25$ ksi, for bending at R.T. and 50 ksi at 77 deg.K). Buckling margins for the short column extensions exceed the project requirements (> 5). The room temperature lower sigma fatigue curve shown in figure 36 indicates we have substantial margin on the $2 \times S$ @130,000 cycles and $20 \times$ life requirements.

Appendix I

Appendix I documents the prior analysis with lower dead loads and earlier support locations.

New model - Hexahedral-shaped TF bracket, higher weight and reviced Ex and Alpx

Loads	Items	Unit	Model 1R	Remarks	Comments
Dead load <ul style="list-style-type: none"> • w/o Wt. increase • stellalloy E=199GPa 	D max	mm	3.02E-01 (-0.292 to 0.0314)	w/o support block	Dmax at PF6
	DZ	mm		w/o support block PowerGraphics OFF	
	Seqv	Pa	1.10E+08	PowerGraphics OFF	Max.Seqv at sup. Block
	Seqv OB	ksi	1.60E+01	PowerGraphics OFF	Max.Seqv at sup. Block
	reaction OB	N	1.53E+05		
	reaction IB	kip	3.43E+01	Total weight	
	reaction IB	N	1.60E+05	3.122E+05	G10 shim on PF6 sup.
	reaction	kip	3.59E+01	7.018E+01	Calculated weight
Dead load <ul style="list-style-type: none"> • DL Factor = 1.14 • stellalloy E=199GPa 	D max	mm	3.34E-01 (-0.324 - 0.0310)	w/o support block	Dmax at PF6
	DZ	mm		w/o support block PowerGraphics OFF	
	Seqv	Pa	9.68E+07	PowerGraphics OFF	Max.Seqv at sup. Block
	Seqv OB	ksi	1.40E+01	PowerGraphics OFF	Max.Seqv at sup. Block
	reaction OB	N	1.82E+05		
	reaction IB	kip	4.09E+01	Total weight	
	reaction IB	N	1.74E+05	3.559E+05	G10 shim on PF6 sup.
	reaction	kip	3.91E+01	8.001E+01	
Dead load <ul style="list-style-type: none"> • DL Factor = 1.14 • stellalloy E=145GPa • Regular PF shim 	D max	mm	3.33E-01 (-0.323 to 0.0314)	w/o support block	Dmax at PF6
	DZ	mm		w/o support block PowerGraphics OFF	
	Seqv	Pa	9.68E+07	PowerGraphics OFF	Max.Seqv at sup. Block
	Seqv OB	ksi	1.40E+01	PowerGraphics OFF	Max.Seqv at sup. Block
	reaction	N	1.74E+05		

	OB reaction	kip	3.92E+01	Total weight	
	IB reaction	N	1.82E+05	3.561E+05	SS shim on PF6 sup.
	IB reaction	kip	4.09E+01	8.005E+01	
EM load	D max	mm	2.793	w/o support block	Type C modular coil
• stellalloy E=145GPa	DZ	mm	(-0.993 - 1.359)	w/o support block	
• Regular PF shim	Seqv	Pa	4.05E+08	PowerGraphics OFF	MCWF flange shim
	Seqv	ksi	5.87E+01	PowerGraphics OFF	
	OB reaction	N	6.61E+04		
	OB reaction	kip	1.49E+01	Total weight	
	IB reaction	N	-6.62E+04	-9.900E+01	SS shim on PF6 sup.
	IB reaction	kip	-1.49E+01	-2.226E-02	
DL & EM	D max	mm	2.766	w/o support block	Dmax at MC type C
• DL Factor = 1.14	DZ	mm	(-1.152 - 1.199)	w/o support block	
• stellalloy E=145GPa	Seqv	Pa	4.05E+08	PowerGraphics OFF	at TF shim?, others 2.51E8
	Seqv	ksi	5.87E+01	PowerGraphics OFF	
	OB reaction	N	2.40E+05		
	OB reaction	kip	5.40E+01	Total weight	
	IB reaction	N	1.16E+05	3.558E+05	SS shim on PF6 sup.
	IB reaction	kip	2.60E+01	7.999E+01	
DL & Cooldown	D max	mm	4.51	w/o support block	Dmax at TF coil mid-plane
• DL Factor = 1.14	DZ	mm	(-1.019 - 1.144)	w/o support block	
• stellalloy E=145GPa	Seqv	Pa	4.75E+08	PowerGraphics OFF	TF bracket
• PF shim Gxy/50	Seqv	ksi	6.89E+01	PowerGraphics OFF	
	OB reaction	N	2.46E+05		
	OB reaction	kip	5.52E+01	Total weight	
	IB reaction	N	1.10E+05	3.559E+05	G10 shim on PF6 sup.
	IB reaction	kip	2.48E+01	8.001E+01	

<p>DL & Cooldown</p> <ul style="list-style-type: none"> • DL Factor = 1.14 • stellalloy E=145GPa • Regular PF shim 	D max	mm	4.509	w/o support block	Dmax at TF coil mid-plane
	DZ	mm	(-0.990 - 1.112)	w/o support block	
	Seqv	Pa	4.78E+08	PowerGraphics OFF	TF bracket
	Seqv	ksi	6.93E+01	PowerGraphics OFF	
	OB reaction	N	2.46E+05		
	OB reaction	kip	5.52E+01	Total weight	
	IB reaction	N	1.10E+05	3.559E+05	G10 shim on PF6 sup.
	IB reaction	kip	2.48E+01	8.001E+01	
<p>DL & Cooldown</p> <ul style="list-style-type: none"> • DL Factor = 1.14 • stellalloy E=145GPa • Regular PF shim • PF shim COF effect 	D max	mm	4.505	w/o support block	Dmax at TF coil mid-plane
	DZ	mm	(-1.253 - 1.389)	w/o support block	
	Seqv	Pa	6.00E+08	PowerGraphics OFF	TF bracket
	Seqv	ksi	8.70E+01	PowerGraphics OFF	
	OB reaction	N	2.46E+05		
	OB reaction	kip	5.53E+01	Total weight	
	IB reaction	N	1.10E+05	3.561E+05	SS shim on PF6 sup.
	IB reaction	kip	2.48E+01	8.005E+01	
<p>DL & Cooldown</p> <ul style="list-style-type: none"> • DL Factor = 1.14 • stellalloy E=145GPa • Regular PF shim • PF shim COF effect • TF shim COF effect 	D max	mm	4.026	w/o support block	Dmax at TF coil mid-plane
	DZ	mm	(-1.321 - 1.465)	w/o support block	
	Seqv	Pa	8.32E+08	PowerGraphics OFF	TF bracket
	Seqv	ksi	1.21E+02	PowerGraphics OFF	
	OB reaction	N	3.26E+05		
	OB reaction	kip	7.32E+01	Total weight	
	IB reaction	N	3.04E+04	3.561E+05	SS shim on PF6 sup.
	IB reaction	kip	6.83E+00	8.005E+01	
<p>Cooldown</p> <ul style="list-style-type: none"> • stellalloy E=145GPa • Regular PF shim 	D max	mm	4.074	w/o support block	Dmax at TF coil mid-plane
	DZ	mm	(-1.314 - 1.643)	w/o support block	
	Seqv	Pa	8.31E+08	PowerGraphics OFF	TF bracket

• PF shim COF effect	Seqv	ksi	1.21E+02	PowerGraphics OFF	
• TF shim COF effect	OB reaction	N	1.52E+05		
Run: co-h2	reaction	kip	3.42E+01	Total weight	
	IB reaction	N	-1.52E+05	0.000E+00	SS shim on PF6 sup.
	IB reaction	kip	-3.42E+01	0.000E+00	
Cooldown	D max	mm	4.078	w/o support block	Dmax at TF coil mid-plane
• stellalloy E=145GPa	DZ	mm	(-1.445 - 1.615)	w/o support block	
• Regular PF shim	Seqv	Pa	8.31E+08	PowerGraphics OFF	TF bracket
• PF shim COF effect	Seqv OB	ksi	1.21E+02	PowerGraphics OFF	ALPX=2.90E-5
• TF shim COF effect	reaction OB	N	6.91E+04		ALPX=2.90E-5
Vertical spring support	reaction	kip	1.55E+01	Total weight	
Run: co-h3	reaction IB	N	-6.91E+04	0.000E+00	SS shim on PF6 sup.
	reaction	kip	-1.55E+01	0.000E+00	
Change alpx for shim					
Cooldown	D max	mm	4.692	w/o support block	Dmax at TF coil mid-plane
• stellalloy E=145GPa	DZ	mm	(-0.932 - 1.180)	w/o support block	
• Regular PF shim	Seqv	Pa	4.71E+08	PowerGraphics OFF	TF bracket
• PF shim COF effect	Seqv OB	ksi	6.83E+01	PowerGraphics OFF	ALPX=9.829E-6
• TF shim COF effect	reaction OB	N	2.08E+04		ALPX=9.829E-6
Vertical spring support	reaction	kip	4.67E+00	Total weight	
Run: co-h3a	reaction IB	N	-2.08E+04	0.000E+00	SS shim on PF6 sup.
	reaction	kip	-4.67E+00	0.000E+00	
Cooldown	D max	mm	4.667	w/o support block	Dmax at TF coil mid-plane
• stellalloy E=145GPa	DZ	mm	(-0.823 - 0.877)	w/o support block	
• Regular PF shim	Seqv	Pa	4.69E+08	PowerGraphics OFF	TF bracket
• PF shim COF effect	Seqv OB	ksi	6.80E+01	PowerGraphics OFF	ALPX=9.829E-6
• TF shim COF effect	reaction	N	8.29E+03		ALPX=9.829E-6

Vertical spring support	OB reaction	kip	1.86E+00	Total weight	
Run: co-h4	IB reaction	N	-8.29E+03	0.000E+00	SS shim on PF6 sup.
w/PF6 link	IB reaction	kip	-1.86E+00	0.000E+00	
Dead load	D max	mm	5.39	w/o support block	Dmax at PF6
• stellalloy E=145GPa	DZ	mm	(-5.37 - 0)	w/o support block	
• Regular PF shim	Seqv	Pa	9.51E+07	PowerGraphics OFF	TF bracket
• PF shim COF effect	Seqv	ksi	1.38E+01	PowerGraphics OFF	ALPX=9.829E-6
• TF shim COF effect	OB reaction	N	1.79E+05		ALPX=9.829E-6
Vertical spring support	OB reaction	kip	4.02E+01	Total weight	
Run: dl-h4	IB reaction	N	1.78E+05	3.571E+05	SS shim on PF6 sup.
w/PF6 link	IB reaction	kip	4.01E+01	8.028E+01	add wt. from PF6 links
EM load	D max	mm	2.794	w/o support block	Type C modular coil
• stellalloy E=145GPa	DZ	mm	(-0.998 - 1.323)	w/o support block	
• Regular PF shim	Seqv	Pa	4.05E+08	PowerGraphics OFF	MCWF flange shim
• PF shim COF effect	Seqv	ksi	5.87E+01	PowerGraphics OFF	ALPX=9.829E-6
• TF shim COF effect	OB reaction	N	2.36E+04		ALPX=9.829E-6
Vertical spring support	OB reaction	kip	5.30E+00	Total weight	
Run: em-h4	IB reaction	N	-2.37E+04	-9.900E+01	SS shim on PF6 sup.
w/PF6 link	IB reaction	kip	-5.32E+00	-2.226E-02	
Cooldown	D max	mm	4.062	w/o support block	Dmax at TF coil mid-plane
• stellalloy E=145GPa	DZ	mm	(-0.942 - 0.896)	w/o support block	
• Regular PF shim	Seqv	Pa	4.64E+08	PowerGraphics OFF	TF bracket
• PF shim COF effect	Seqv	ksi	6.73E+01	PowerGraphics OFF	ALPX=9.829E-6
• TF shim COF effect	OB reaction	N	4.42E+04		ALPX=9.829E-6
Vertical spring support	OB reaction	kip	9.93E+00	Total weight	
Run: co-h4a	IB reaction	N	-4.42E+04	0.000E+00	SS shim on PF6 sup.
w/PF6 link & bonded TF shim	IB reaction	kip	-9.93E+00	0.000E+00	

<p>EM load</p> <ul style="list-style-type: none"> • stellalloy E=145GPa • Regular PF shim • PF shim COF effect • TF shim COF effect <p>Vertical spring support</p> <p>Run: em-h4a</p> <p>w/PF6 link & bonded TF shim</p>	D max	mm	2.756	w/o support block	Type C modular coil
	DZ	mm	(-1.02 - 1.322)	w/o support block	
	Seqv	Pa	4.03E+08	PowerGraphics OFF	MCWF flange shim
	Seqv OB	ksi	5.85E+01	PowerGraphics OFF	ALPX=9.829E-6
	reaction OB	N	2.95E+04		ALPX=9.829E-6
	reaction IB	kip	6.63E+00	Total weight	
	reaction IB	N	-2.96E+04	-1.000E+02	SS shim on PF6 sup.
	reaction IB	kip	-6.65E+00	-2.248E-02	
<p>DL, EM & Cooldown</p> <ul style="list-style-type: none"> • stellalloy E=145GPa • Regular PF shim • PF shim COF effect • TF shim COF effect <p>Vertical spring support</p> <p>Run: h5-emdlco-2T000s</p> <p>w/PF6 link</p>	D max	mm	5.154	w/o support block	Dmax at TF coil mid-plane
	DZ	mm	(-1.889 - 1.252)	w/o support block	Dzmax at PF coil (near center)
	Seqv	Pa	5.01E+08	PowerGraphics OFF	TF bracket?
	Seqv OB	ksi	7.27E+01	PowerGraphics OFF	ALPX=9.829E-6
	reaction OB	N	2.06E+05		ALPX=9.829E-6
	reaction IB	kip	4.64E+01	Total weight	
	reaction IB	N	1.51E+05	3.570E+05	SS shim on PF6 sup.
	reaction IB	kip	3.39E+01	8.026E+01	
<p>*Note: model h5 running from single step file is identical to model h4 (from multi-step files)</p>					
<p>DL, EM & Cooldown</p> <ul style="list-style-type: none"> • stellalloy E=145GPa • Regular PF shim • PF shim COF effect • TF shim COF effect <p>New support springs</p> <p>Run: h6-emdlco-2T-HB000s</p> <p>w/PF6 link</p>	D max	mm	5.829	unsel Type255-spring	Dmax at TF coil mid-height
	DZ	mm	(-4.307 to -1.167)	unsel Type255-spring	Dzmax at PF coil (near center)
	Seqv	Pa	5.00E+08	PowerGraphics OFF	TF bracket?
	Seqv OB	ksi	7.25E+01	PowerGraphics OFF	ALPX=9.829E-6
	reaction OB	N	1.90E+05		ALPX=9.829E-6
	reaction IB	kip	4.28E+01	Total weight	
	reaction IB	N	1.67E+05	3.570E+05	SS shim on PF6 sup.
	reaction IB	kip	3.75E+01	8.026E+01	
<p>DL, EM & Cooldown</p>	D max	mm	6.838	unsel Type255-spring	Dmax at TF coil mid-height

<ul style="list-style-type: none"> • stellalloy E=145GPa • Regular PF shim • PF shim COF effect • TF shim COF effect <p>New support springs Run: h6-emdlco-2T-HB440s</p>	DZ	mm	(-4.330 to -1.190)	unsel Type255-spring	Dzmax at PF coil (near center)
	Seqv	Pa	4.97E+08	PowerGraphics OFF	TF bracket?
	Seqv	ksi	7.21E+01	PowerGraphics OFF	ALPX=9.829E-6
	OB	N	1.89E+05		ALPX=9.829E-6
	reaction	kip	4.26E+01	Total weight	
	IB	N	1.67E+05	3.562E+05	SS shim on PF6 sup.
w/PF6 link	reaction	kip	3.75E+01	8.007E+01	
<p>DL, EM & Cooldown</p> <ul style="list-style-type: none"> • stellalloy E=145GPa • Regular PF shim • PF shim COF effect • TF shim COF effect <p>New support springs Run: h6-emdlco-17T-Om000s</p>	D max	mm	6.26 (-4.066 to -1.446)	unsel Type255-spring	Dmax at TF coil mid-height
	DZ	mm		unsel Type255-spring	Dzmax at PF6 coil
	Seqv	Pa	5.03E+08	PowerGraphics OFF	TF bracket?
	Seqv	ksi	7.30E+01	PowerGraphics OFF	ALPX=9.829E-6
	OB	N	1.89E+05		ALPX=9.829E-6
	reaction	kip	4.25E+01	Total weight	
IB	N	1.67E+05	3.564E+05	SS shim on PF6 sup.	
w/PF6 link	reaction	kip	3.76E+01	8.013E+01	
<p>DL, EM & Cooldown</p> <ul style="list-style-type: none"> • stellalloy E=145GPa • Regular PF shim • PF shim COF effect • TF shim COF effect <p>New support springs Run: h6-emdlco-17T-Om440s</p>	D max	mm	5.699 (-4.154 to -1.471)	unsel Type255-spring	Dmax at TF coil mid-height
	DZ	mm		unsel Type255-spring	Dzmax at PF6 coil
	Seqv	Pa	4.90E+08	PowerGraphics OFF	TF bracket?
	Seqv	ksi	7.11E+01	PowerGraphics OFF	ALPX=9.829E-6
	OB	N	1.89E+05		ALPX=9.829E-6
	reaction	kip	4.25E+01	Total weight	
IB	N	1.68E+05	3.570E+05	SS shim on PF6 sup.	
w/PF6 link	reaction	kip	3.77E+01	8.027E+01	
<p>DL, EM & Cooldown</p> <ul style="list-style-type: none"> • stellalloy E=145GPa • Regular PF shim • PF shim COF effect 	D max	mm	9.664 (-4.131 to -1.395)	unsel Type255-spring	Dmax at TF coil mid-height
	DZ	mm		unsel Type255-spring	Dzmax at PF6 coil
	Seqv	Pa	4.96E+08	PowerGraphics OFF	TF bracket
	Seqv	ksi	7.19E+01	PowerGraphics OFF	ALPX=9.829E-6

• TF shim COF effect	OB reaction	N	1.87E+05		ALPX=9.829E-6
New support springs	OB reaction	kip	4.21E+01	Total weight	
Run: h6-emdlco-17T-iota065	IB reaction	N	1.66E+05	3.530E+05	SS shim on PF6 sup.
w/PF6 link	IB reaction	kip	3.73E+01	7.937E+01	
DL, EM & Cooldown	D max	mm	9.296 (-3.939 to -1.453)	unsel Type255-spring	Dmax at TF coil mid-height
• stellalloy E=145GPa	DZ	mm		unsel Type255-spring	Dzmax at PF6 coil
• Regular PF shim	Seqv	Pa	4.85E+08	PowerGraphics OFF	TF bracket
• PF shim COF effect	Seqv	ksi	7.04E+01	PowerGraphics OFF	ALPX=9.829E-6
• TF shim COF effect	OB reaction	N	1.84E+05		ALPX=9.829E-6
New support springs	OB reaction	kip	4.13E+01	Total weight	
Run: h6-emdlco-17T-iota019	IB reaction	N	1.64E+05	3.478E+05	SS shim on PF6 sup.
w/PF6 link	IB reaction	kip	3.69E+01	7.819E+01	
DL, EM & Cooldown	D max	mm	5.671 (-4..039 to -1.386)	unsel Type255-spring	Dmax at TF coil mid-height
• stellalloy E=145GPa	DZ	mm		unsel Type255-spring	Dzmax at PF6 coil
• Regular PF shim	Seqv	Pa	4.95E+08	PowerGraphics OFF	TF bracket?
• PF shim COF effect	Seqv	ksi	7.18E+01	PowerGraphics OFF	ALPX=9.829E-6
• TF shim COF effect	OB reaction	N	1.90E+05		ALPX=9.829E-6
New support springs	OB reaction	kip	4.26E+01	Total weight	
Run: h6-emdlco-17T-shear01	IB reaction	N	1.67E+05	3.570E+05	SS shim on PF6 sup.
w/PF6 link	IB reaction	kip	3.76E+01	8.026E+01	
DL, EM & Cooldown	D max	mm	4.86 (-3.629 to -1.978)	unsel Type255-spring	Dmax at TF coil mid-height
• stellalloy E=145GPa	DZ	mm		unsel Type255-spring	Dzmax at PF6 bracket
• Regular PF shim	Seqv	Pa	4.72E+08	PowerGraphics OFF	TF bracket
• PF shim COF effect	Seqv	ksi	6.85E+01	PowerGraphics OFF	ALPX=9.829E-6
• TF shim COF effect	OB reaction	N	1.80E+05		ALPX=9.829E-6
New support springs	OB reaction	kip	4.05E+01	Total weight	
Run: h6-emdlco-05T-TF	IB reaction	N	1.64E+05	3.442E+05	SS shim on PF6 sup.

w/PF6 link	IB reaction	kip	3.69E+01	7.739E+01	
EM & Cooldown	D max	mm	3.976	unsel Type255-spring	Dmax at TF coil mid-height
• stellalloy E=145GPa	DZ	mm	(-0.693 to 0.980)	unsel Type255-spring	Dzmax at PF6 bracket
• Regular PF shim	Seqv	Pa	4.64E+08	PowerGraphics OFF	TF bracket
• PF shim COF effect	Seqv OB	ksi	6.73E+01	PowerGraphics OFF	ALPX=9.829E-6
• TF shim COF effect	reaction OB	N	-5.91E+03		ALPX=9.829E-6
New support springs	reaction IB	kip	-1.33E+00	Total weight	
Run: h6-emco-05T-TFa	reaction IB	N	-6.96E+03	-1.287E+04	SS shim on PF6 sup.
w/PF6 link	reaction IB	kip	-1.56E+00	-2.893E+00	
Cooldown	D max	mm	4.667	unsel Type255-spring	Dmax at TF coil mid-height?
• stellalloy E=145GPa	DZ	mm	(-0.820 to 0.879)	unsel Type255-spring	Dzmax at PF6 bracket?
• Regular PF shim	Seqv	Pa	4.68E+08	PowerGraphics OFF	TF bracket?
• PF shim COF effect	Seqv OB	ksi	6.79E+01	PowerGraphics OFF	ALPX=9.829E-6
• TF shim COF effect	reaction OB	N	-1.27E+03		ALPX=9.829E-6
New support springs	reaction OB	kip	-2.86E-01	Total weight	
Run: h6-co-05T-TFb	reaction IB	N	1.27E+03	0.000E+00	SS shim on PF6 sup.
w/PF6 link	reaction IB	kip	2.86E-01	0.000E+00	
EM Load	D max	mm	0.708	unsel Type255-spring	Dmax at TF coil mid-height?
• stellalloy E=145GPa	DZ	mm	(0.006 to 0.244)	unsel Type255-spring	Dzmax at PF6 bracket?
• Regular PF shim	Seqv	Pa	3.37E+07	PowerGraphics OFF	TF bracket?
• PF shim COF effect	Seqv OB	ksi	4.89E+00	PowerGraphics OFF	ALPX=9.829E-6
• TF shim COF effect	reaction OB	N	-7.18E+03		ALPX=9.829E-6
New support springs	reaction OB	kip	-1.61E+00	Total weight	
Run: h6-em-05T-TFc	reaction IB	N	-5.69E+03	-1.287E+04	SS shim on PF6 sup.
w/PF6 link	reaction IB	kip	-1.28E+00	-2.893E+00	

Appendix I-a

Appendix I-a is the final analysis using the updated base support locations and higher dead loads and includes various additional loading from trim coils and maximum loading from Iota flexibility studies.

H9 Model Run Summaries

New model - Hexahedral-shaped TF Bracket, 100-kip Dead Weight, Trim Coil Load and New Supports

Loads and Notes	Items	Unit	Model 1R	Remarks	Comments	Note	Seqv	Loc.
DL & EM Run: h8-empl-2T-HB197s-b.tcam • G10 ALPX=15.0E-6 • with negative trim coil load	D max	mm	5.58	unsel Type255-spring	Dmax at TF coil mid-height			
	DZ	mm	(-4.509 to -2.422)	unsel Type255-spring	(Dz)max,min at MC Type C	4.629 Tesla		
	Seqv	Pa	3.96E+08	PowerGraphics OFF	MCWF shim tip at 0 deg.		1.72E+08	TF bracket
	Seqv	ksi	5.74E+01	PowerGraphics OFF			2.49E+01	ksi
	OB reaction Rz	N	2.35E+05			node 480731	1.50E+08	PF4 bracket
	OB reaction Rz	kip	5.29E+01			node 480731	2.18E+01	ksi
	OB Rr & Rθ	N	0 / -2131			node 480733	8.09E+07	PF6 bracket
	IB Rr & Rθ	N	0 / -84	Total weight		node 480732	1.17E+01	ksi
	IB reaction Rz	N	2.13E+05	4.478E+05	SS shim on PF6 sup.	node 480730		
	IB reaction Rz	kip	4.78E+01	1.007E+02		node 480730		
DL & EM Run: h9-empl-2T-HB197s-b.tca • G10 ALPX=15.0E-6 • with positive trim coil load	D max	mm	5.27	unsel Type255-spring	Dmax at TF coil mid-height			
	DZ	mm	(-4.509 to -2.422)	unsel Type255-spring	(Dz)max,min at MC Type C	4.629 Tesla		
	Seqv	Pa	3.96E+08	PowerGraphics OFF	MCWF shim tip at 0 deg.		1.75E+08	TF bracket
	Seqv	ksi	5.74E+01	PowerGraphics OFF			2.54E+01	ksi
	OB reaction Rz	N	2.35E+05			node 480731	1.53E+08	PF4 bracket
	OB reaction Rz	kip	5.29E+01			node 480731	2.22E+01	ksi
	OB Rr & Rθ	N	0 / 3085			node 480733	7.61E+07	PF6 bracket
	IB Rr & Rθ	N	0 / -13	Total weight		node 480732	1.10E+01	ksi
	IB reaction Rz	N	2.13E+05	4.478E+05	SS shim on PF6 sup.	node 480730		
	IB reaction Rz	kip	4.78E+01	1.007E+02		node 480730		
DL, EM & Cooldown Run: h9-emplco-2T-HB197s-b.tcam • G10 ALPX=15.0E-6 • with negative trim coil load	D max	mm	7.291	unsel Type255-spring	Dmax at TF coil mid-height			
	DZ	mm	(-5.337 to -2.077)	unsel Type255-spring	Dzmin at PF6 coil (near center)	4.629 Tesla		
	Seqv	Pa	4.53E+08	PowerGraphics OFF	PF6 bracket		3.40E+08	TF bracket
	Seqv	ksi	6.57E+01	PowerGraphics OFF			4.93E+01	ksi
	OB reaction Rz	N	2.38E+05			node 480731		
	OB reaction Rz	kip	5.35E+01			node 480731		
	OB Rr & Rθ	N	0 / -2143			node 480733		
	IB Rr & Rθ	N	0 / -80	Total weight		node 480732		
	IB reaction Rz	N	2.10E+05	4.478E+05	SS shim on PF6 sup.	node 480730		
	IB reaction Rz	kip	4.72E+01	1.007E+02		node 480730		

Appendix I-a -H9 Results (cont.)

Loads and Notes	Items	Unit	Model 1R	Remarks	Comments	Note	Seqv	Loc.
DL, EM & Cooldown								
Run: h9-emdico-2T-HB197s-b.tca	D max	mm	7.064	unsel Type255-spring	Dmax at TF coil mid-height			
• G10 ALPX=15.0E-6	DZ	mm	(-5.382 to -2.038)	unsel Type255-spring	Dzmin at PF6 coil (near center)	4.629 Tesla		
• with positive trim coil load	Seqv	Pa	4.56E+08	PowerGraphics OFF	PF6 bracket		3.43E+08	TF bracket
	Seqv	ksi	6.61E+01	PowerGraphics OFF			4.98E+01	ksi
	OB reaction Rz	N	2.38E+05					node 480731
	OB reaction Rz	kip	5.35E+01					node 480731
	OB Rr & Rθ	N	0 /3074		rsys=15			node 480733
	IB Rr & Rθ	N	0 / -9	Total weight	rsys=0			node 480732
	IB reaction Rz	N	2.10E+05	4.478E+05	SS shim on PF6 sup.			node 480730
	IB reaction Rz	kip	4.72E+01	1.007E+02				node 480730
DL, EM & Cooldown								
Run: h9-emdico-17T-OM0s.tca	D max	mm	6.572	unsel Type255-spring	Dmax at TF coil mid-height			
• G10 ALPX=15.0E-6	DZ	mm	(-5.131 to -2.253)	unsel Type255-spring	Dzmin at PF6 coil (near center)	4.202 Tesla		
• with positive trim coil load	Seqv	Pa	4.71E+08	PowerGraphics OFF	PF6 bracket	PG 7.29E+8	3.64E+08	TF bracket
	Seqv	ksi	6.83E+01	PowerGraphics OFF			5.28E+01	ksi
	OB reaction Rz	N	2.37E+05				4.08E+08	PF4 bracket
	OB reaction Rz	kip	5.34E+01				5.92E+01	ksi
	OB Rr & Rθ	N	0 /2500		rsys=15			node 480733
	IB Rr & Rθ	N	0 / -5	Total weight	rsys=0			node 480732
	IB reaction Rz	N	2.11E+05	4.480E+05	SS shim on PF6 sup.			node 480730
	IB reaction Rz	kip	4.73E+01	1.007E+02				node 480730
DL, EM & Cooldown								
Run: h9-emdico-05T-TF-b	D max	mm	5.329	unsel Type255-spring	Dmax at TF coil mid-height			
• G10 ALPX=15.0E-6	DZ	mm	(-4.629 to -2.803)	unsel Type255-spring	Dzmin at PF6 coil (near center)	1.571 Tesla		
• no trim coil load	Seqv	Pa	4.36E+08	PowerGraphics OFF	PF6 bracket	PG 6.86E+8	3.57E+08	TF bracket
	Seqv	ksi	6.32E+01	PowerGraphics OFF			5.18E+01	ksi
	OB reaction Rz	N	2.28E+05				4.01E+08	PF4 bracket
	OB reaction Rz	kip	5.12E+01				5.82E+01	ksi
	OB Rr & Rθ	N	0 /-1.8		rsys=15			node 480733
	IB Rr & Rθ	N	0 / -5.5	Total weight	rsys=0			node 480732
	IB reaction Rz	N	2.08E+05	4.358E+05	SS shim on PF6 sup.			node 480730
	IB reaction Rz	kip	4.68E+01	9.799E+01				node 480730

Appendix II

FIELD PERIOD ASSY WEIGHT

Component	Pro E Weight lbs	tons	contingency	Total Weight tons	delta lbs
Vacuum Vessel	6,776	3.4	5%	3.6	339
Modular Coils	43,402	21.7	5%	22.8	2,170
TF Coils	8,100	4.1	5%	4.3	405
Heating/Cooling Hdwr	529	0.3	5%	0.3	26
PF Coils	5,505	2.8	5%	2.9	275
PFCs & NBL-duct	12,043	6.0	5%	6.3	602
Trim coils & supp'ts	2,007	1.0	5%	1.1	100
PF & TF Structure & C.S.	11,236	5.6	5%	5.9	562
Total Weight	89,599	44.8	5%	47.0	4,480
				47.0	

Does not include

	Guessed Wt.
Insulation	600
Cryostat panels & structure	3,500
Magnetic Loops	100
some of the Fastners	500

Full Period Total Wt.: **94,299**

Full Period Project weight **100,000**
(estimate for design purposes)

APPENDIX III

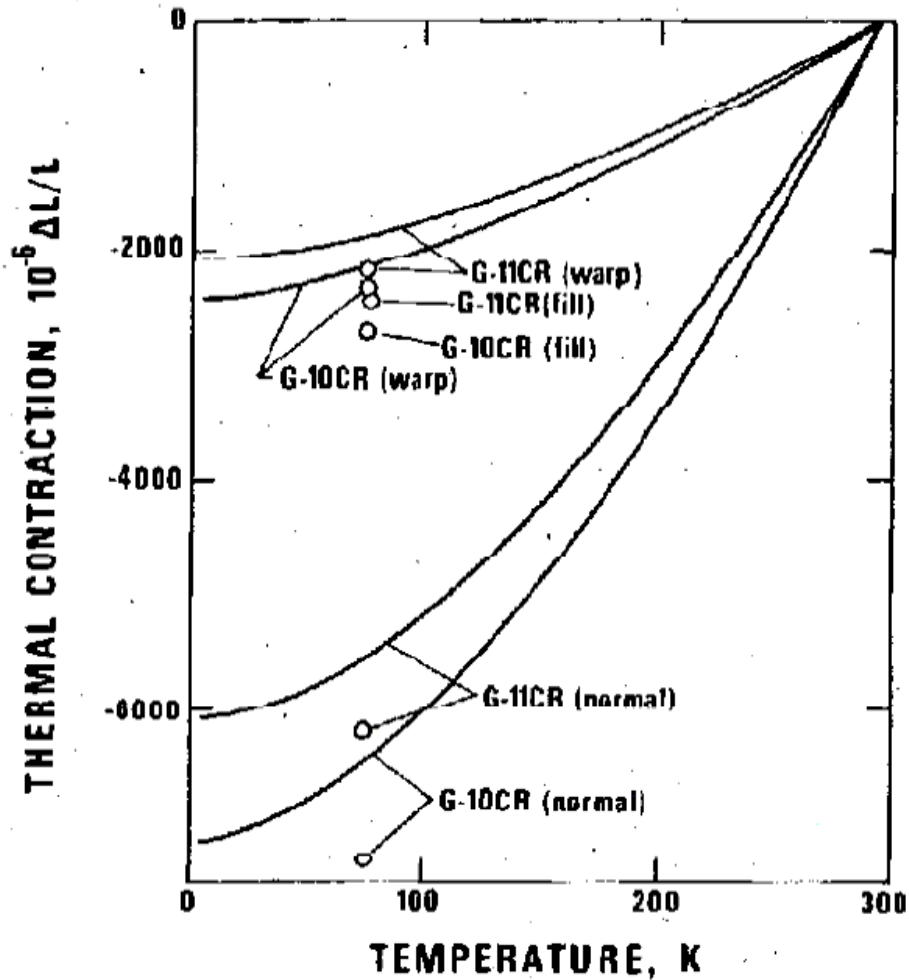

From:

**MECHANICAL, ELECTRICAL, AND THERMAL
CHARACTERIZATION OF G-10CR AND G-11CR
GLASS-CLOTH/EPOXY LAMINATES BETWEEN
ROOM TEMPERATURE AND 4 K***

M. B. Kasen, G. R. MacDonald, D. H. Beckman, Jr., and R. E. Schramm

*National Bureau of Standards
Boulder, Colorado*

Youngs Modulus for Stainless Steel 304 from 4K to 300K

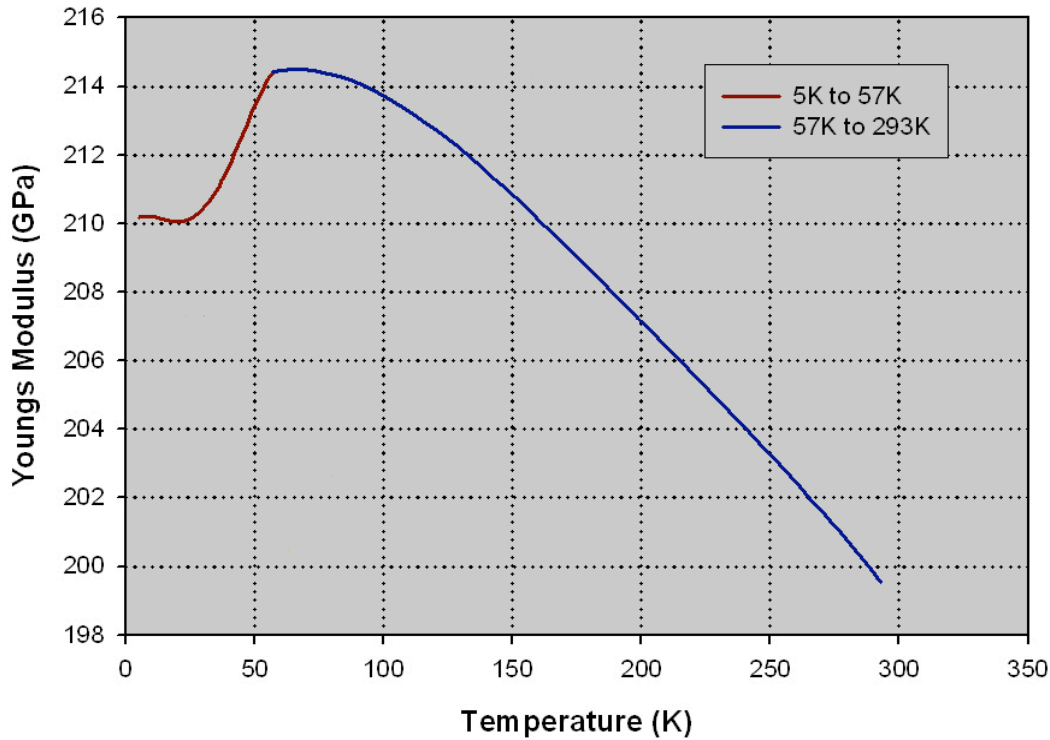

http://cryogenics.nist.gov/MPropsMAY/304Stainless/SS-304_Plots/SS-304_Youngs%20Modulus.JPG

Linear Expansion of Stainless Steel 304 from 4K to 300K

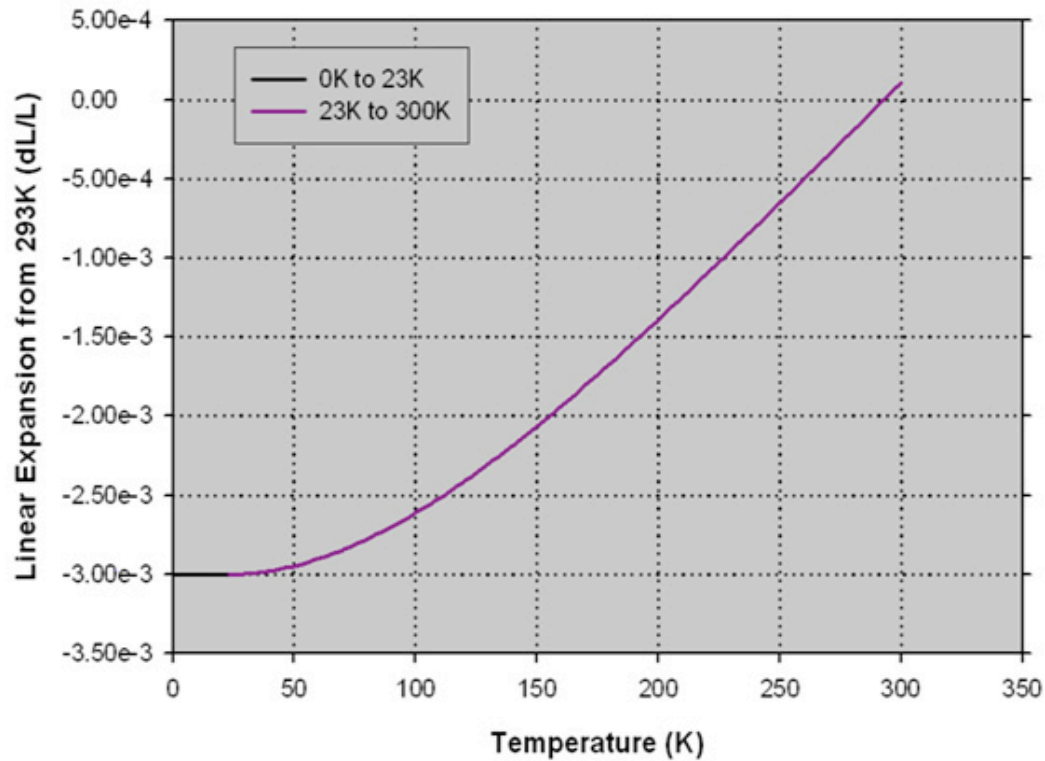

APPENDIX IV

NCSX-TF-PF-STRUCT-304g5h-all4a.db Final FEA ANSYS Model
Material property number assignments:

Matl#	component(s)
1	Inboard pedestal & misc. interface contact surfaces
2-5	base supports
6	base slide plates - outer
7	teflon plates
8	column braces
9-35	MCWF-shell & insulator breaks
36	modular coils
37	scattered mcwf elements
38	TF inner bridges & LHS + RHS outer/lower bridges
39	not used
40	NL elements on lower PF4 supp't. brkts.
41	lower PF4 support brkts.
42-44	not used
45-62	MCWF-interface-insulators
63	upper PF4 support brkts.
64	misc-MCWF interfaces
65	PF5&6 coil-support G10 interface elements
66	TF coil support G10 exterior block-wedge elements
67	MCWF & PF4 brkt. interface contact elements
68	misc. MCWF interface ele.
69	PF6 cantelevered brkts.
70	TF support brkts. & MCWF-to- brkt. short columns & cantelevered spans
71	G10 PF5&6 spacer pieces & interior TF block-wedge elements
72-73	mcwf misc. interface elements
74	TF pre-loading bolts
75	TF Coils
76	PF Coils
77	TF wedge castings
78	TF coil wedge casting interface-contacts
79	not used
80	MCWF misc. interface ele.
81	not used
misc. contact/target surface ele. mat'ls.	
82	MCWF misc. interface ele.
83	not used
84	MCWF misc. interface ele.
85-87	not used
88	MCWF misc. interface ele.
89	not used
90	MCWF misc. interface ele.
91-119	MCWF misc. interface eles.