

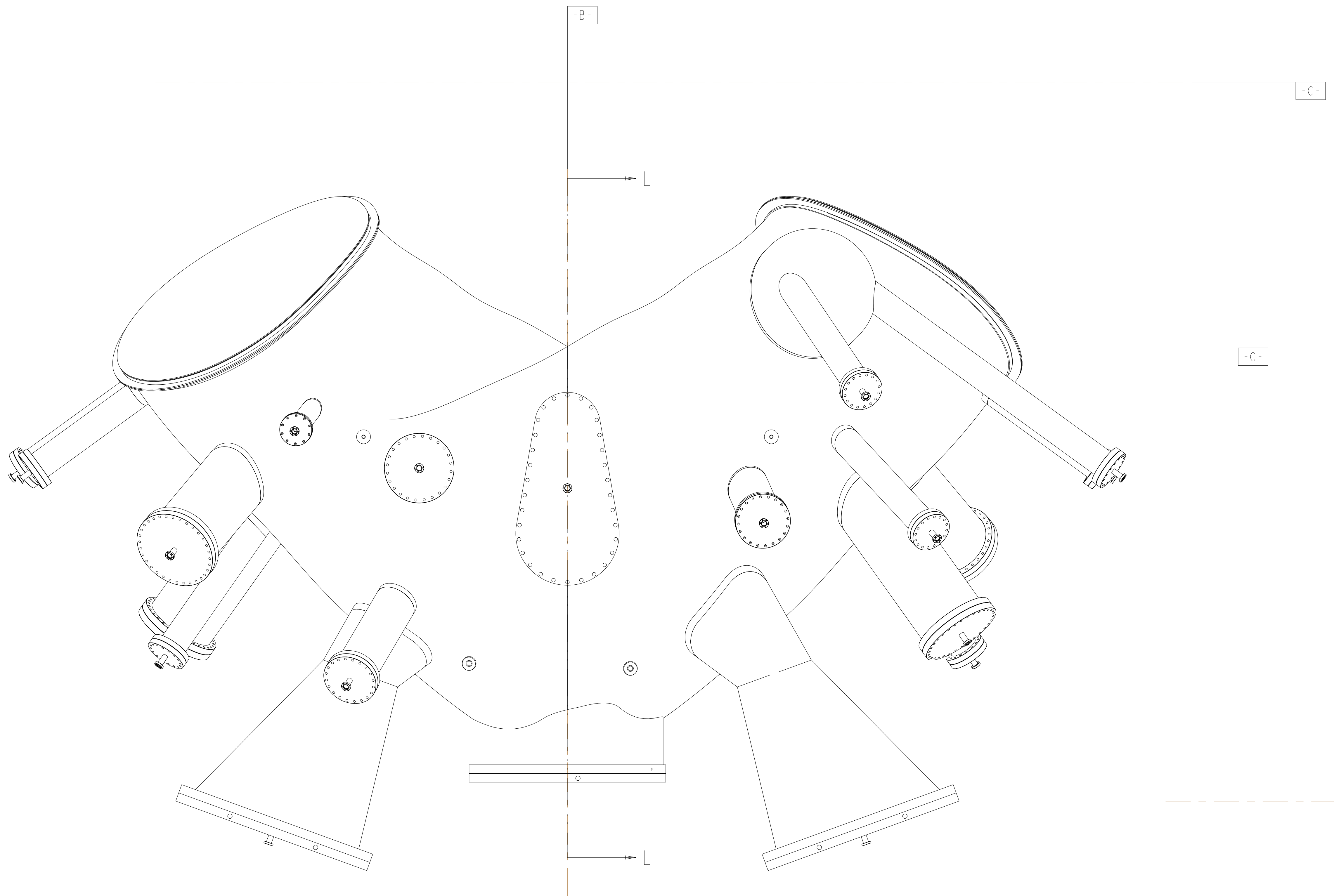

FOR NOTES AND PARTS LIST SEE SHEET 1

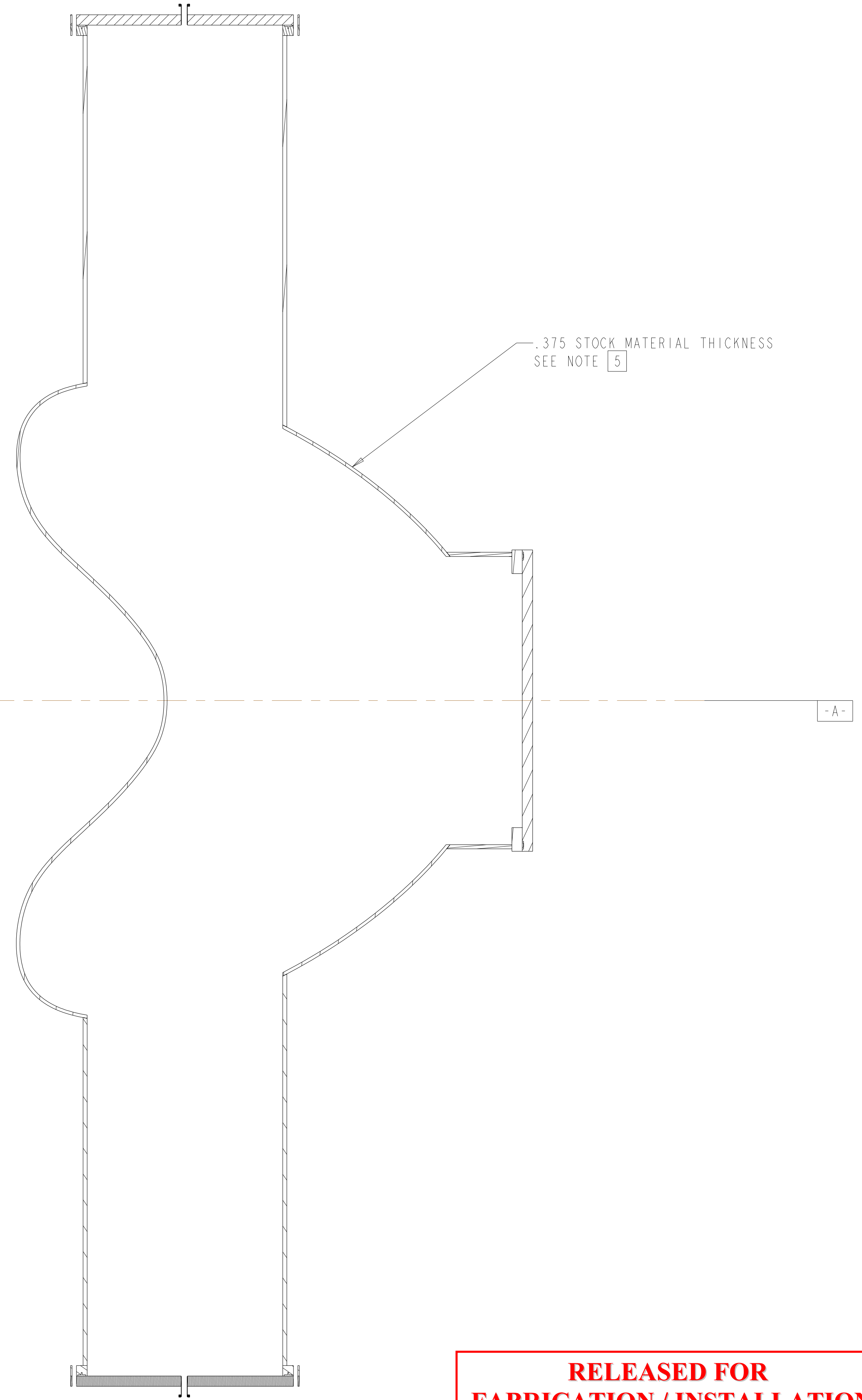

TOP VIEW



SECTION L-L  
 VESSEL THICKNESS

**RELEASED FOR  
 FABRICATION / INSTALLATION**  
 PPPL Drafting:

Oak Ridge National Laboratory managed for the DEPARTMENT OF ENERGY under U.S. GOVERNMENT contract DE-AC05-00OR22725 UT-BATTELLE, LLC, Oak Ridge, Tennessee PROJECT NAME						
NATIONAL COMPACT STELLERATOR EXPERIMENT VACUUM VESSEL PERIOD INSPECTION AND LEAK CHECK ASSEMBLY						
VERSION NO.	PLANT	BLDG	FL	SHT OF	TYPE	CLASS
5	X-10	5700	3	2 19	A	U
RELEASE LEVEL		SE120-004			REV	
Fabrication					2	

H  
G  
F  
E  
D  
C  
B  
A



FOR PARTS LIST AND NOTES SEE SHEET 1.

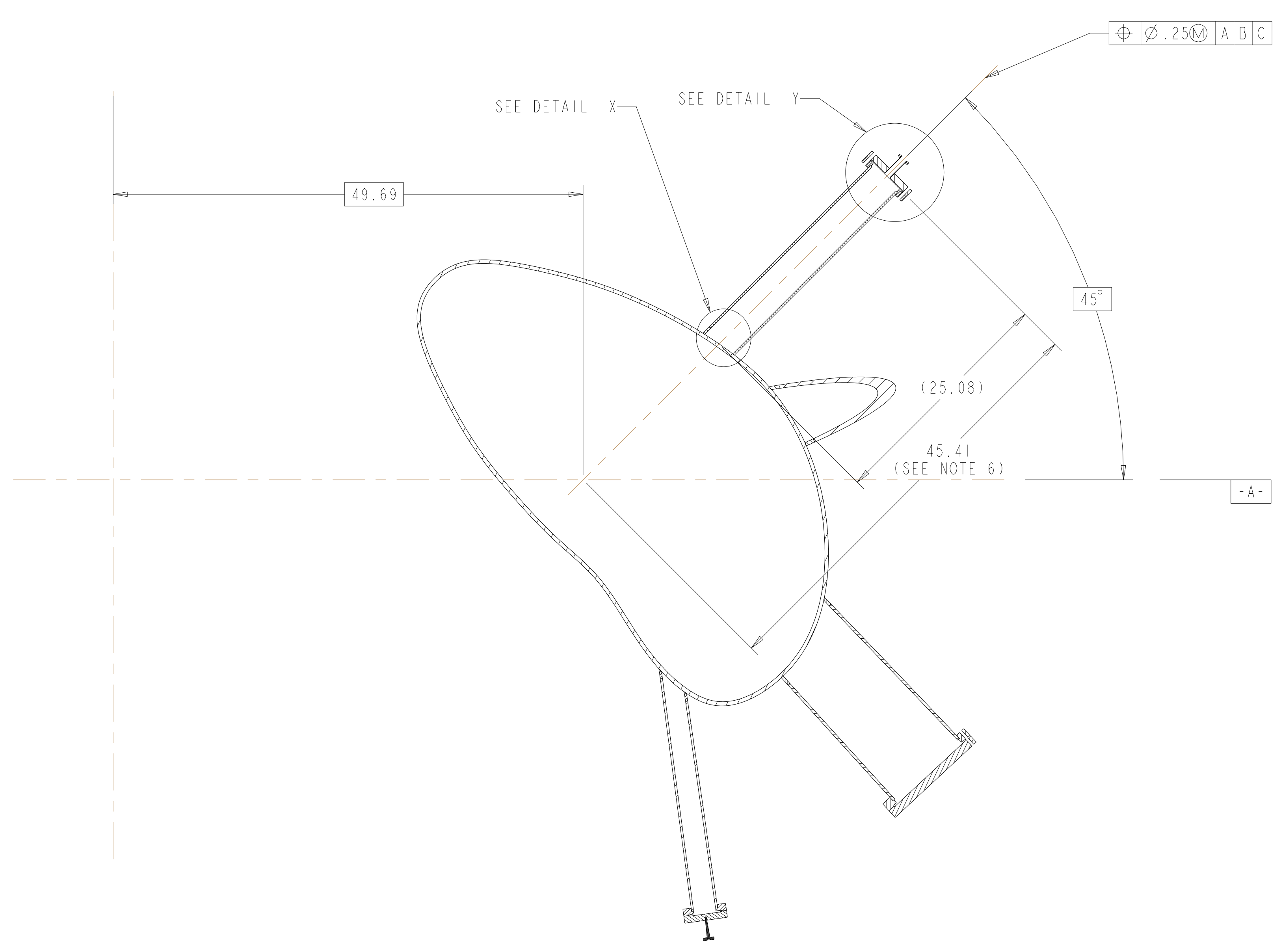
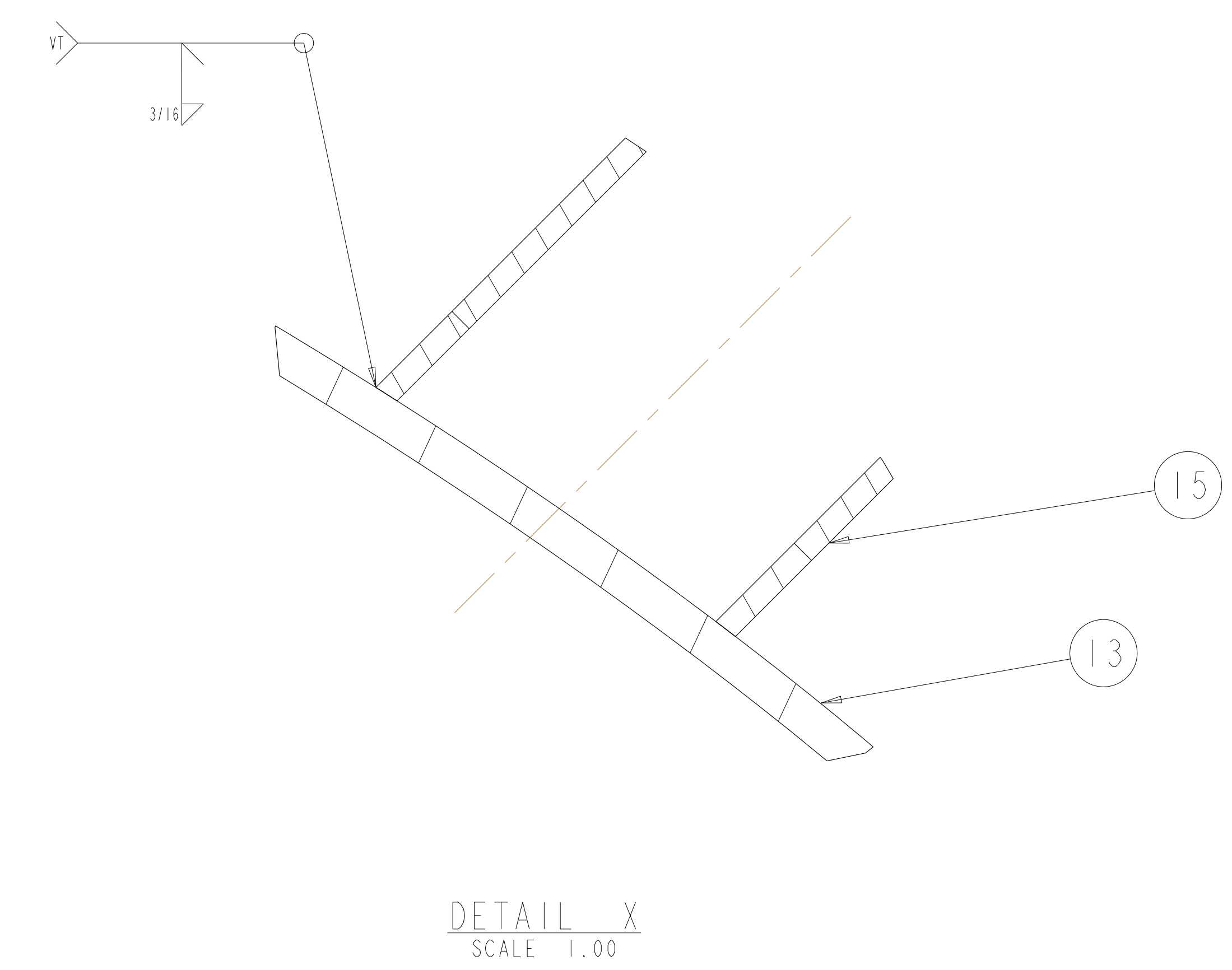
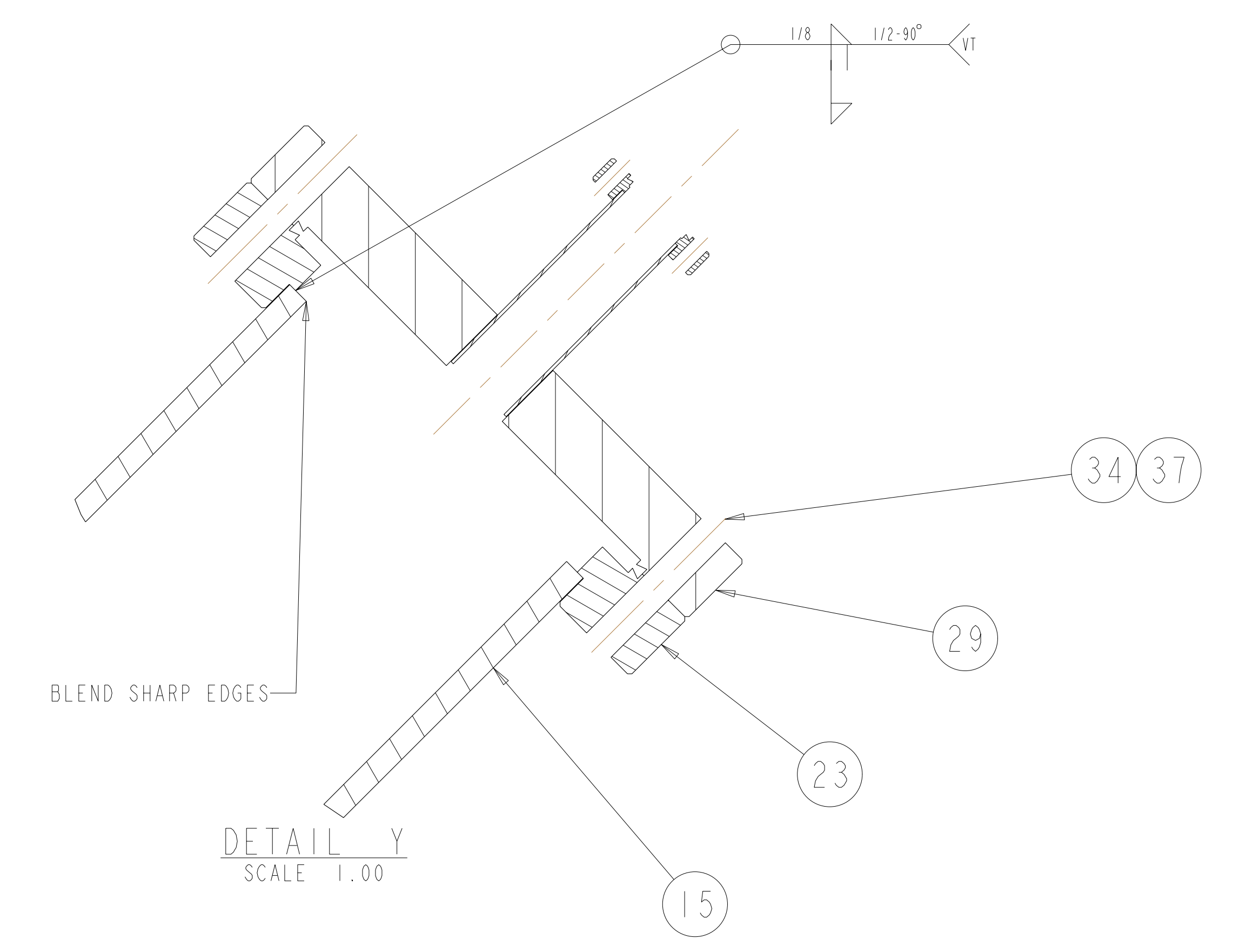
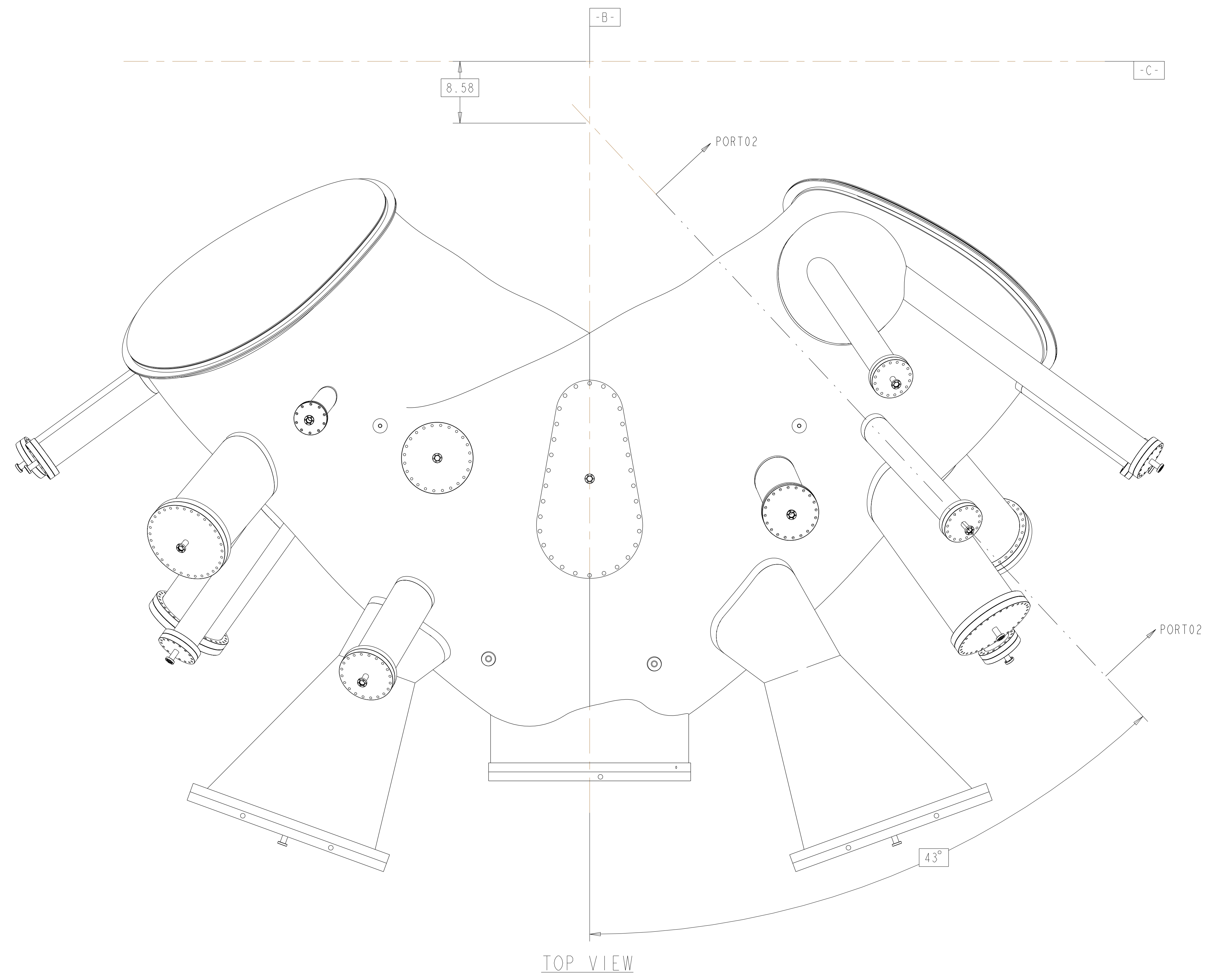

**RELEASED FOR FABRICATION / INSTALLATION**  
 PPPL Drafting:

<b>UT-BATTELLE</b>		Oak Ridge National Laboratory managed for the DEPARTMENT OF ENERGY under U.S. GOVERNMENT contract DE-AC05-00OR22725 UT-BATTELLE, LLC, Oak Ridge, Tennessee					
PROJECT NAME							
NATIONAL COMPACT STELLARATOR EXPERIMENT							
VACUUM VESSEL							
PERIOD INSPECTION AND LEAK CHECK ASSEMBLY							
VERSION NO.	PLANT	BLDG	FL	SHT OF	TYPE	CLASS	
5	X-10	5700	3	4 19	A	U	
RELEASE LEVEL		SE120-004				REV	
Fabrication						2	

H  
G  
F  
E  
D  
C  
B  
A

FOR PARTS LIST AND NOTES SEE SHEET 1.

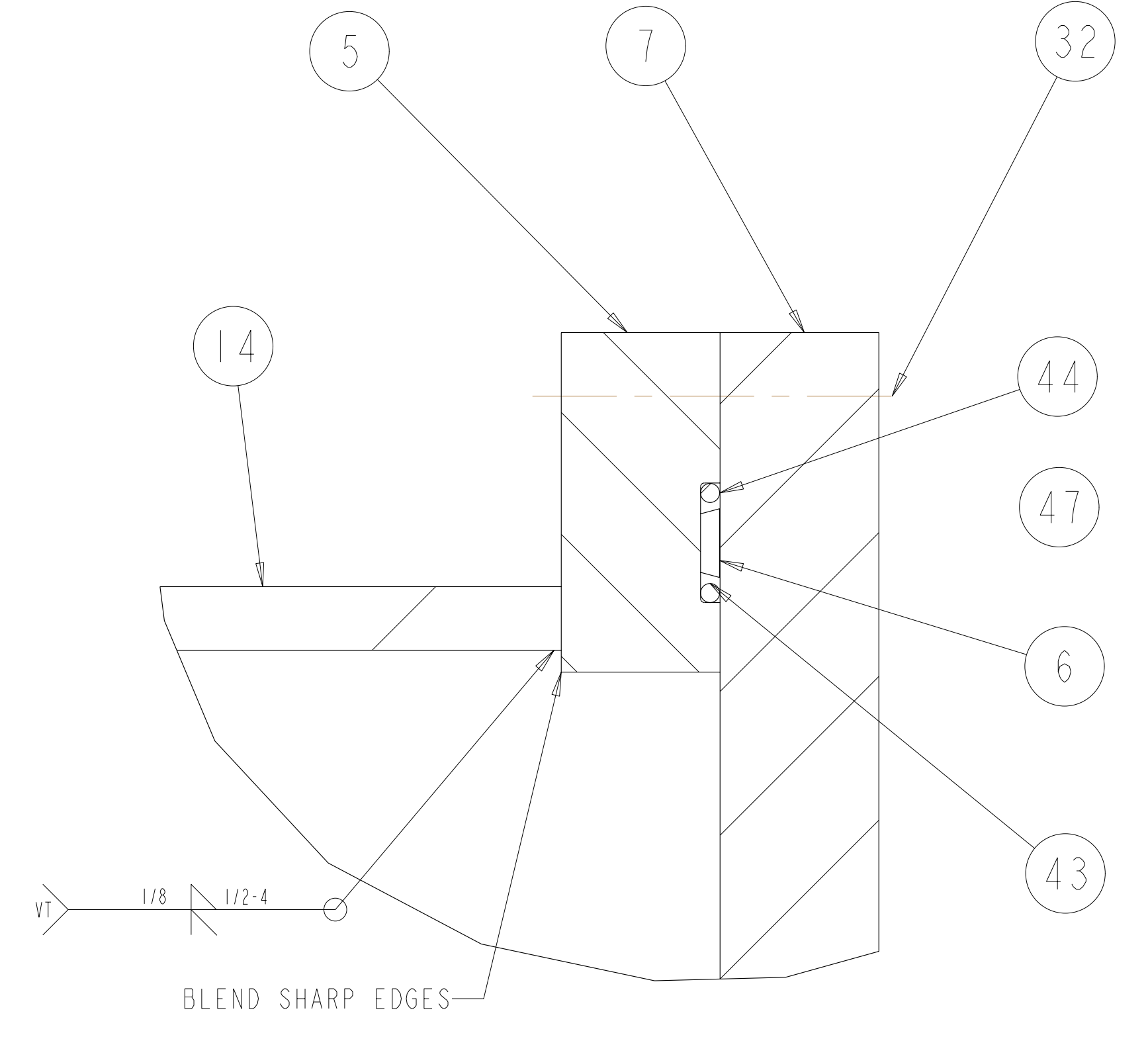
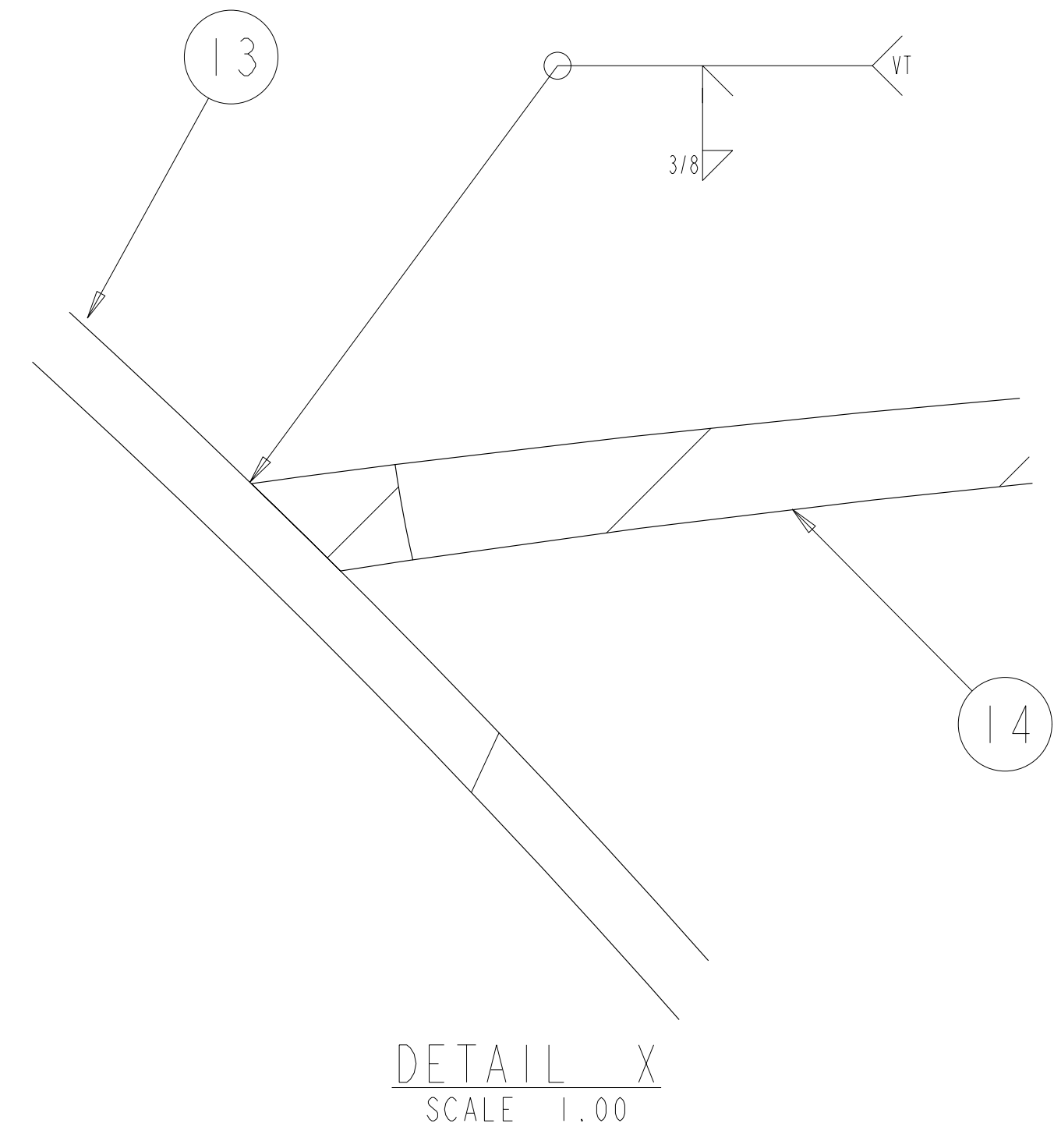
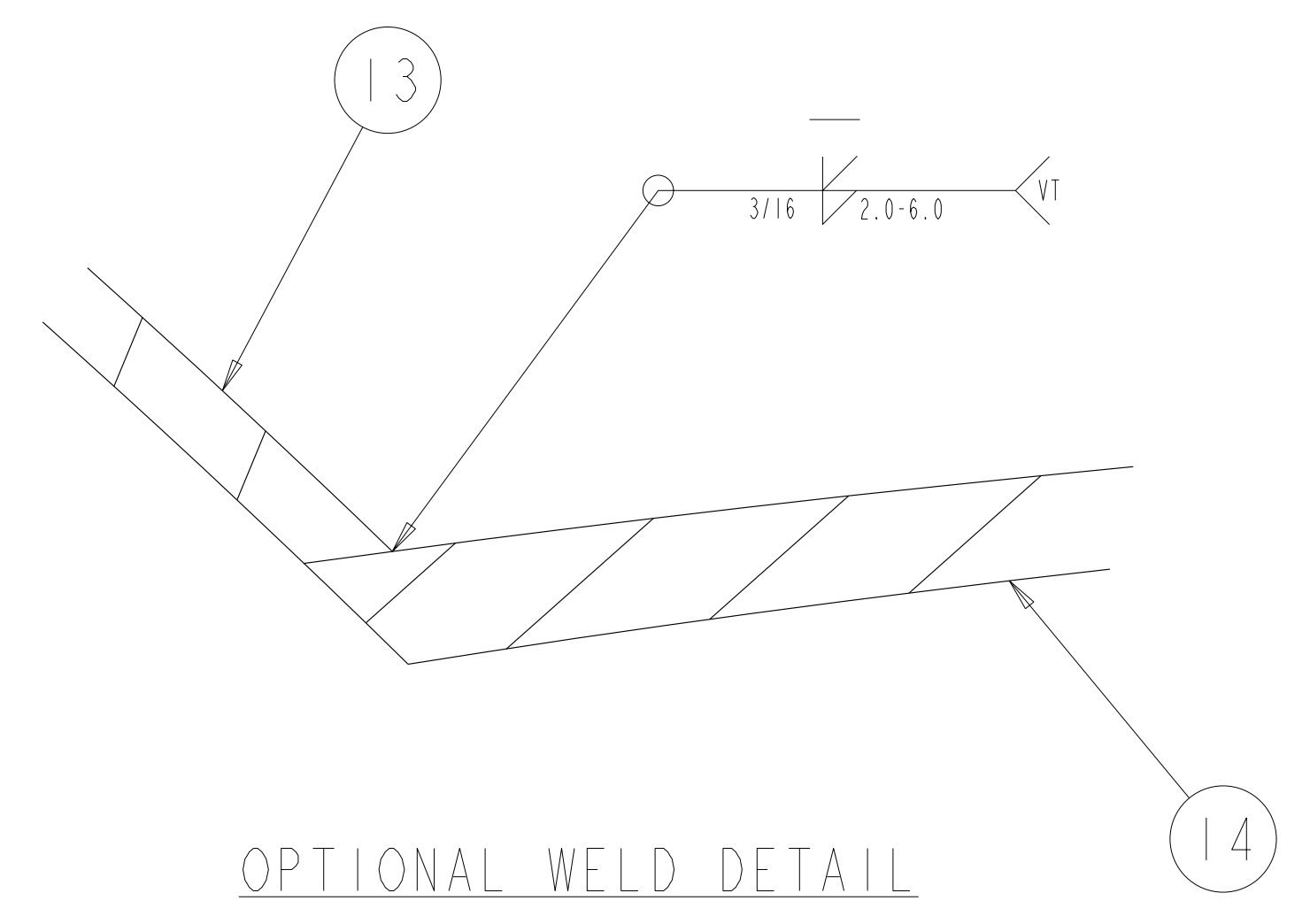
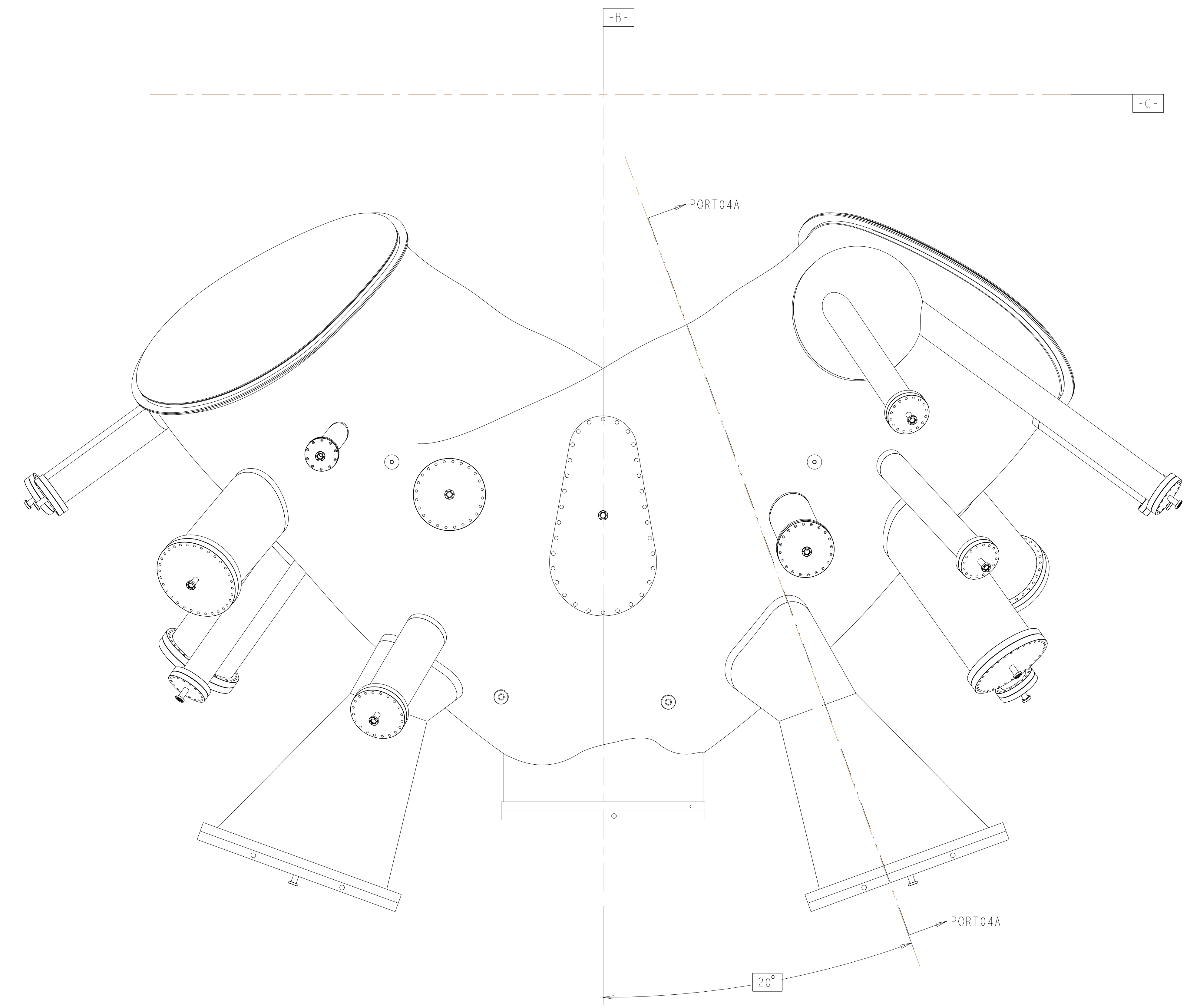

TOP VIEW

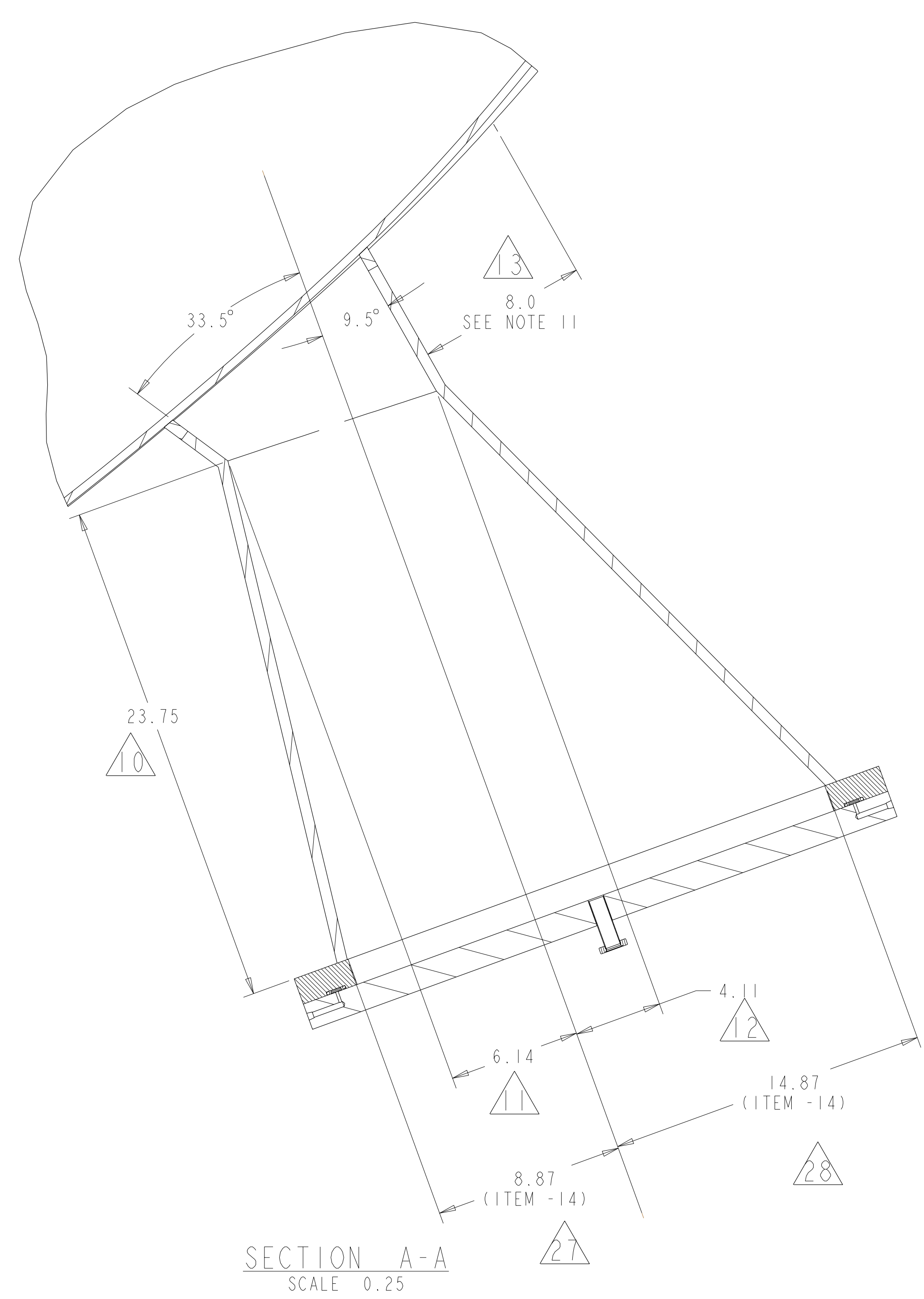
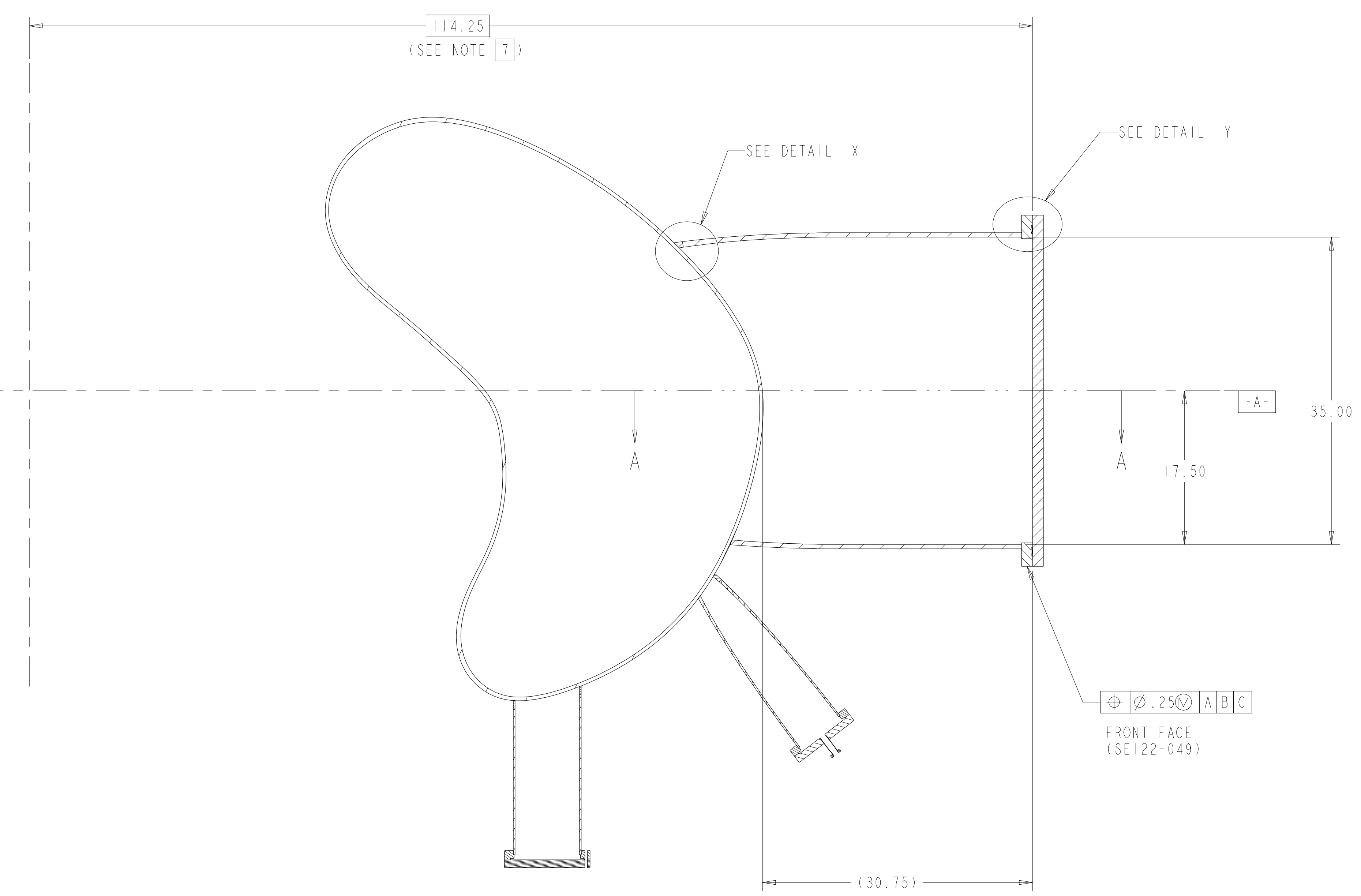

TYPICAL PORT 4A AND 4B SECTION PORT04A-PORT04A

Ø .250 A B C  
 FRONT FACE (SE122-049)

**RELEASED FOR FABRICATION / INSTALLATION**  
 PPPL Drafting:

UT-BATTELLE		Oak Ridge National Laboratory managed for the DEPARTMENT OF ENERGY under U.S. GOVERNMENT contract DE-AC05-00OR22725 UT-BATTELLE, LLC., Oak Ridge, Tennessee					
NATIONAL COMPACT STELLERATOR EXPERIMENT							
VACUUM VESSEL PERIOD INSPECTION AND LEAK CHECK ASSEMBLY							
VERSION NO.	PLANT	BLDG	FL	SHT OF	TYPE	CLASS	
5	X-10	5700	3	5 19	A	U	
RELEASE LEVEL	SE120-004					REV	
Fabrication						2	

H  
G  
F  
E  
D  
C  
B  
A

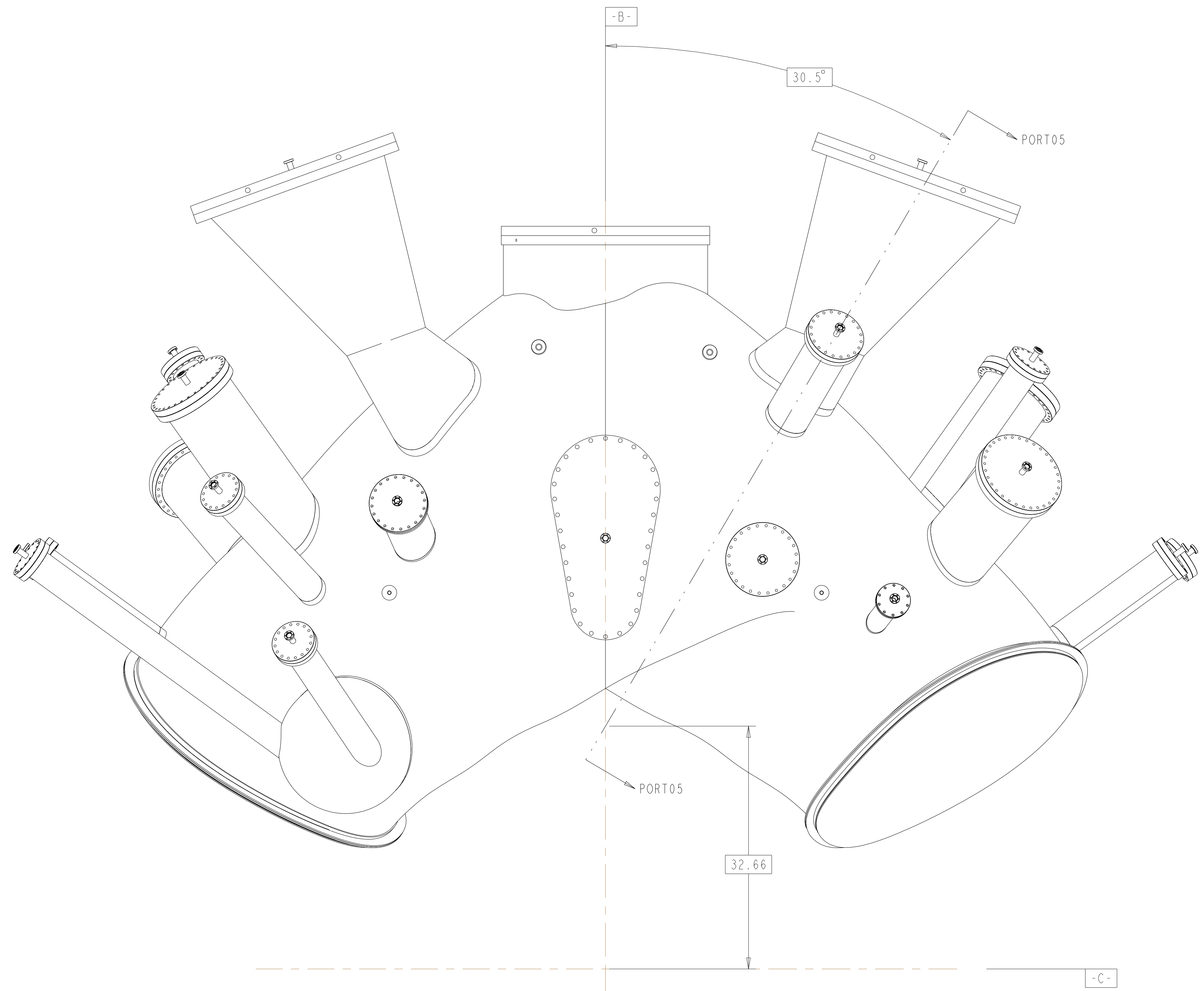

BOTTOM VIEW

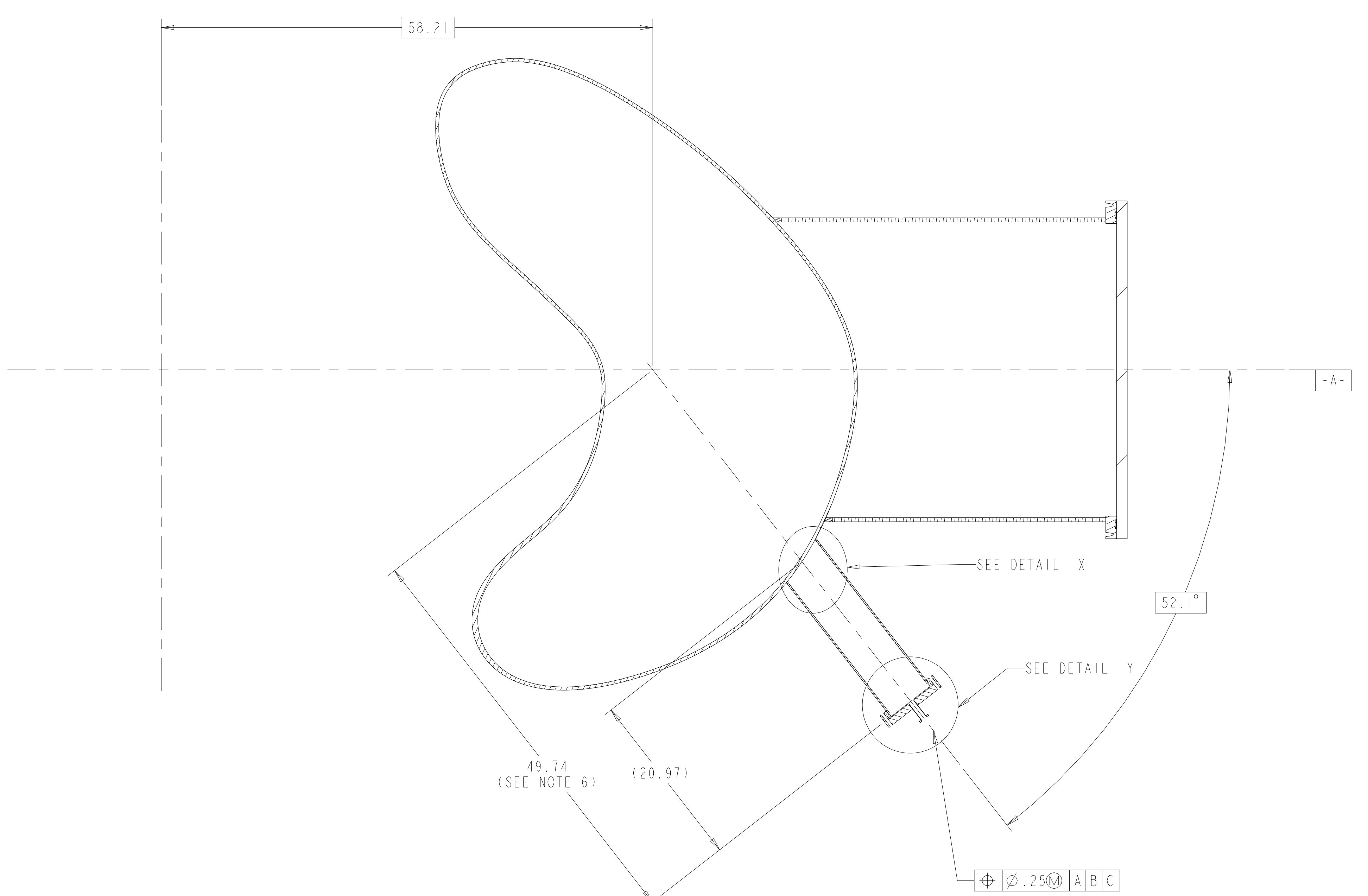

TYPICAL PORT 5A AND 5B SECTION PORT05-PORT05

FOR PARTS LIST AND NOTES SEE SHEET 1.

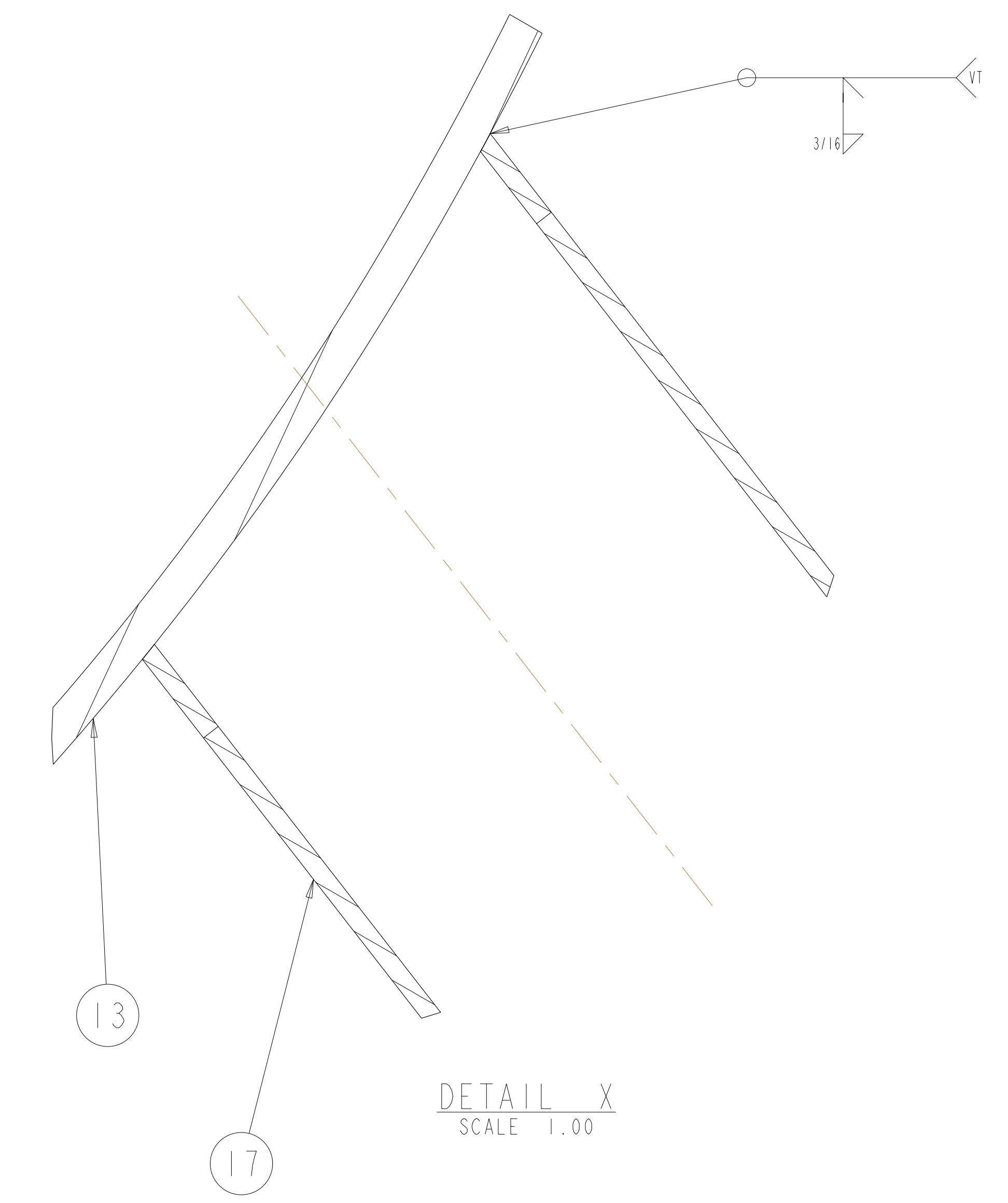

DETAIL X  
SCALE 1.00

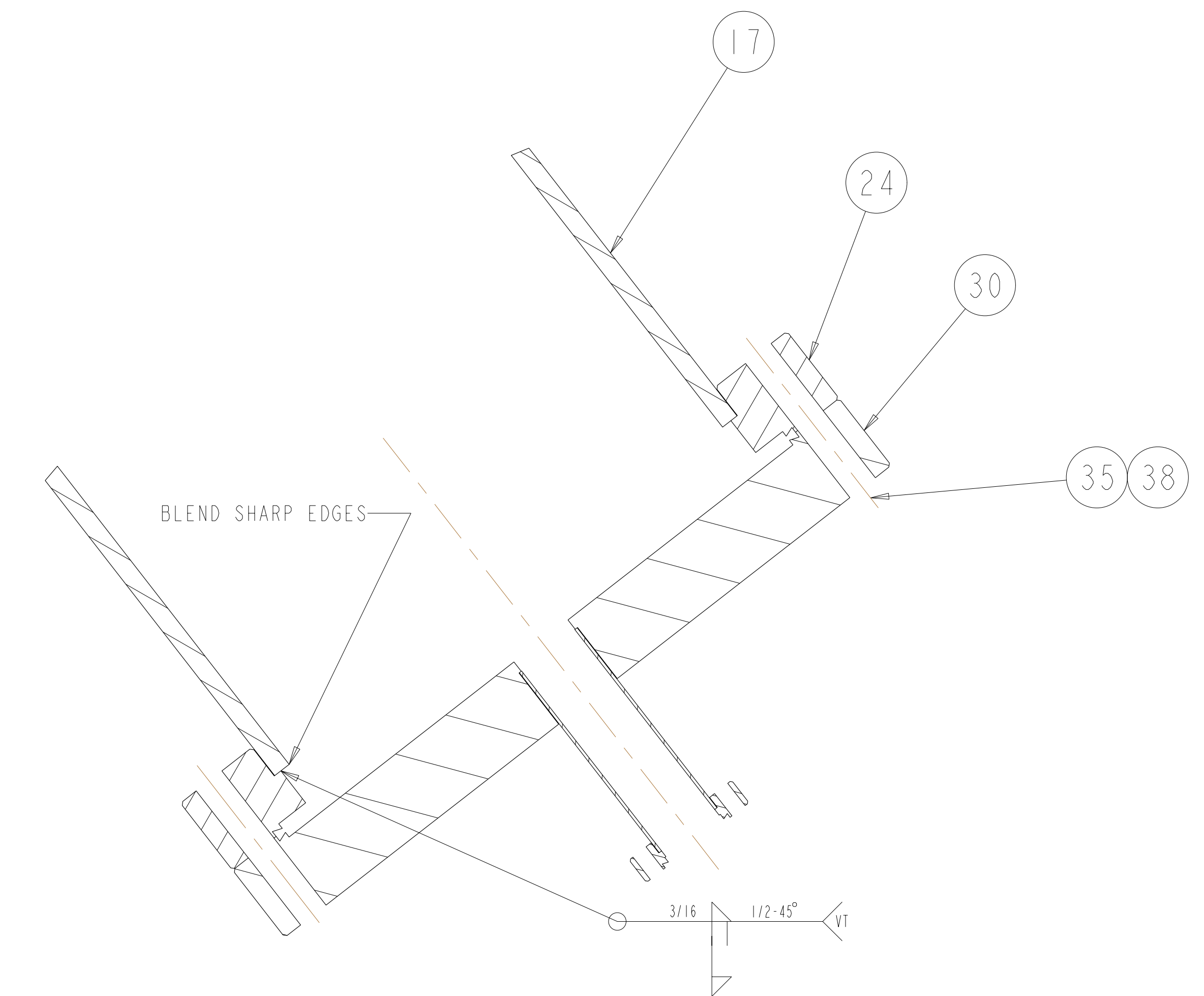

DETAIL Y  
SCALE 1.00

**RELEASED FOR FABRICATION / INSTALLATION**  
 PPPL Drafting:

UT-BATTELLE		Oak Ridge National Laboratory managed for the DEPARTMENT OF ENERGY under U.S. GOVERNMENT contract DE-AC05-00OR22725 UT-BATTELLE, LLC, Oak Ridge, Tennessee					
NATIONAL COMPACT STELLARATOR EXPERIMENT							
VACUUM VESSEL							
PERIOD INSPECTION AND LEAK CHECK ASSEMBLY							
VERSION NO.	PLANT	BLDG	FL	SHT OF	TYPE	CLASS	
5	X-10	5700	3	6	19	A	U
RELEASE LEVEL	SE120-004						REV
Fabrication							2

H  
G  
F  
E  
D  
C  
B  
A

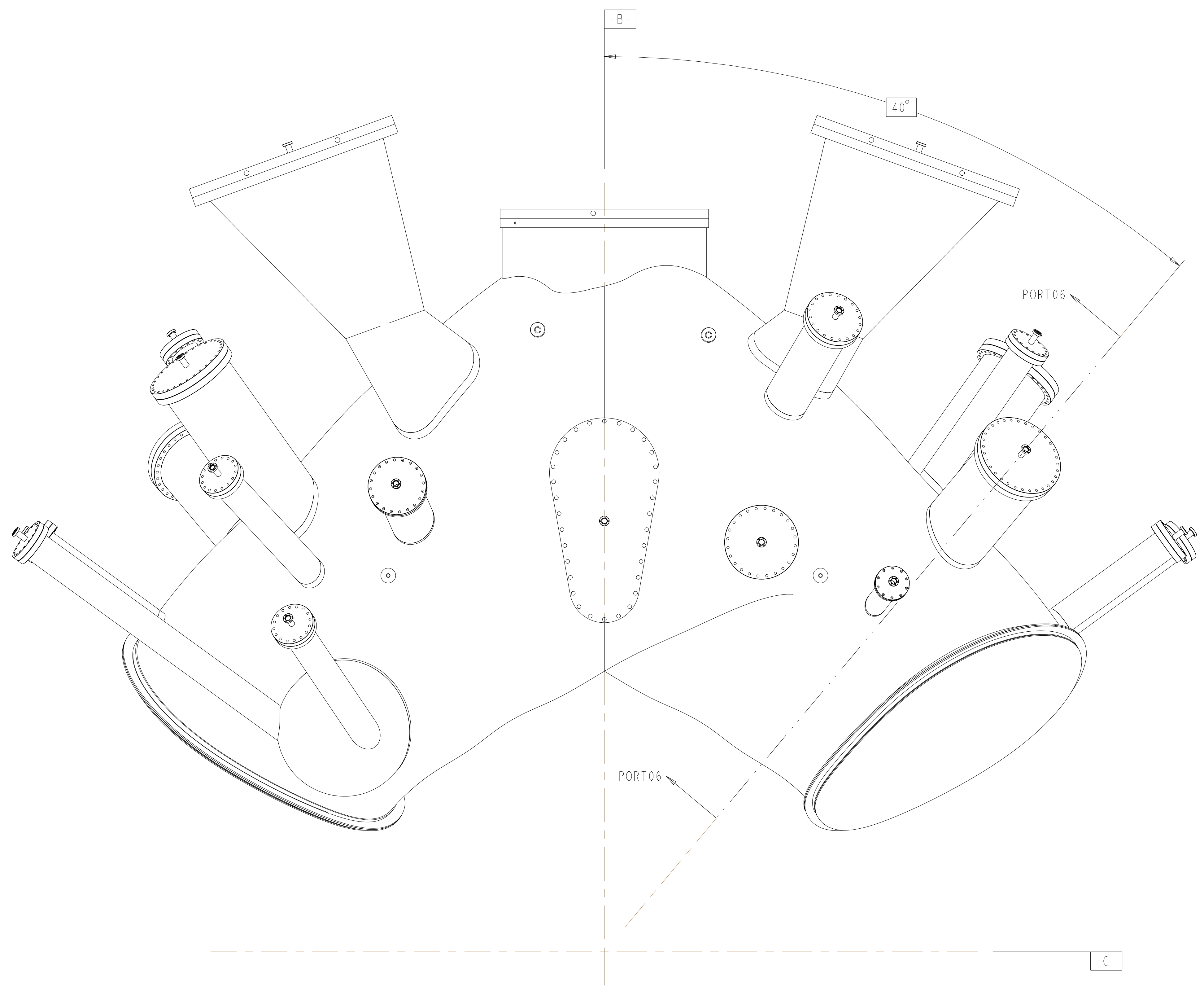

BOTTOM VIEW

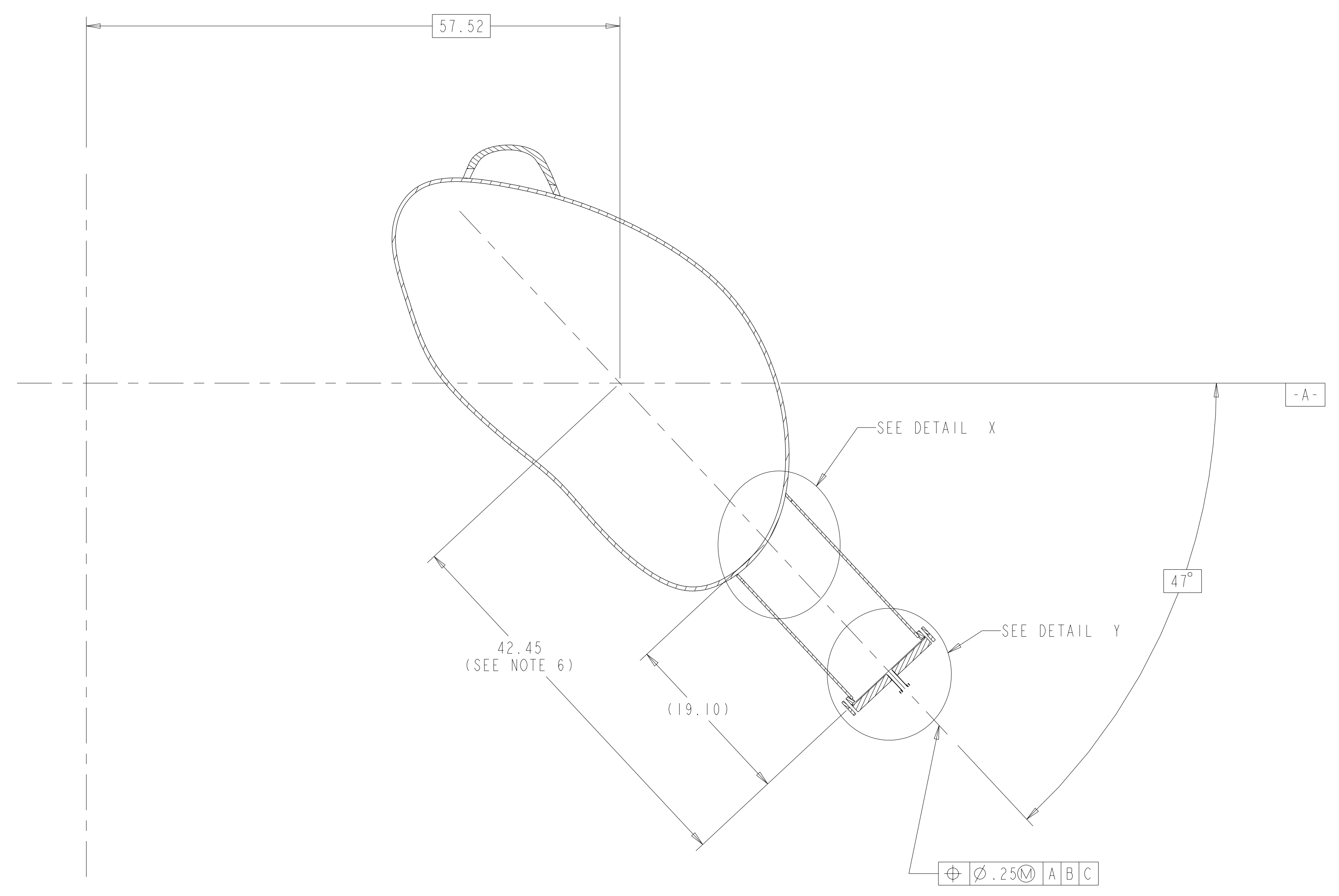

TYPICAL PORT 6A AND 6B  
 SECTION PORT06-PORT06

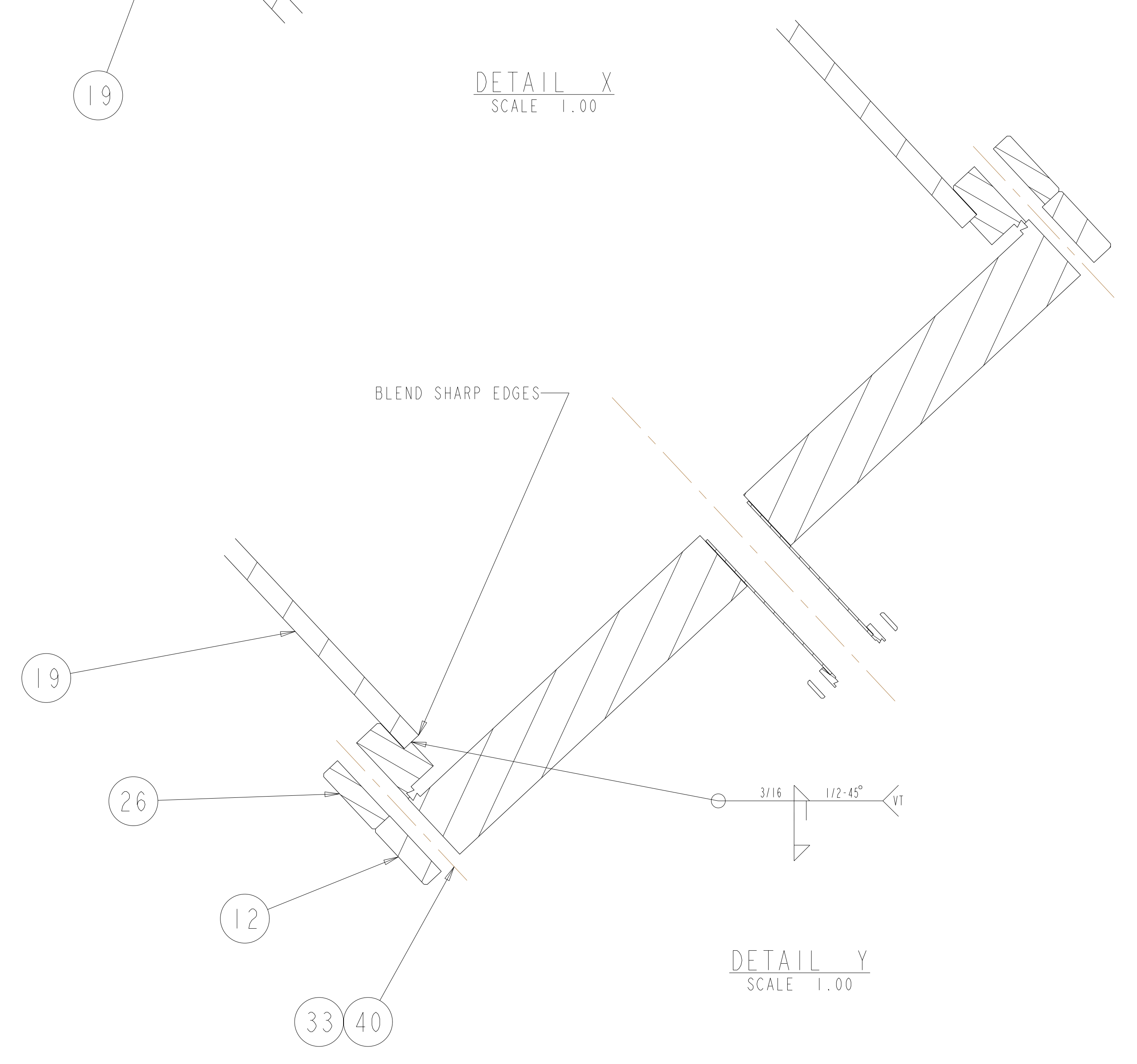
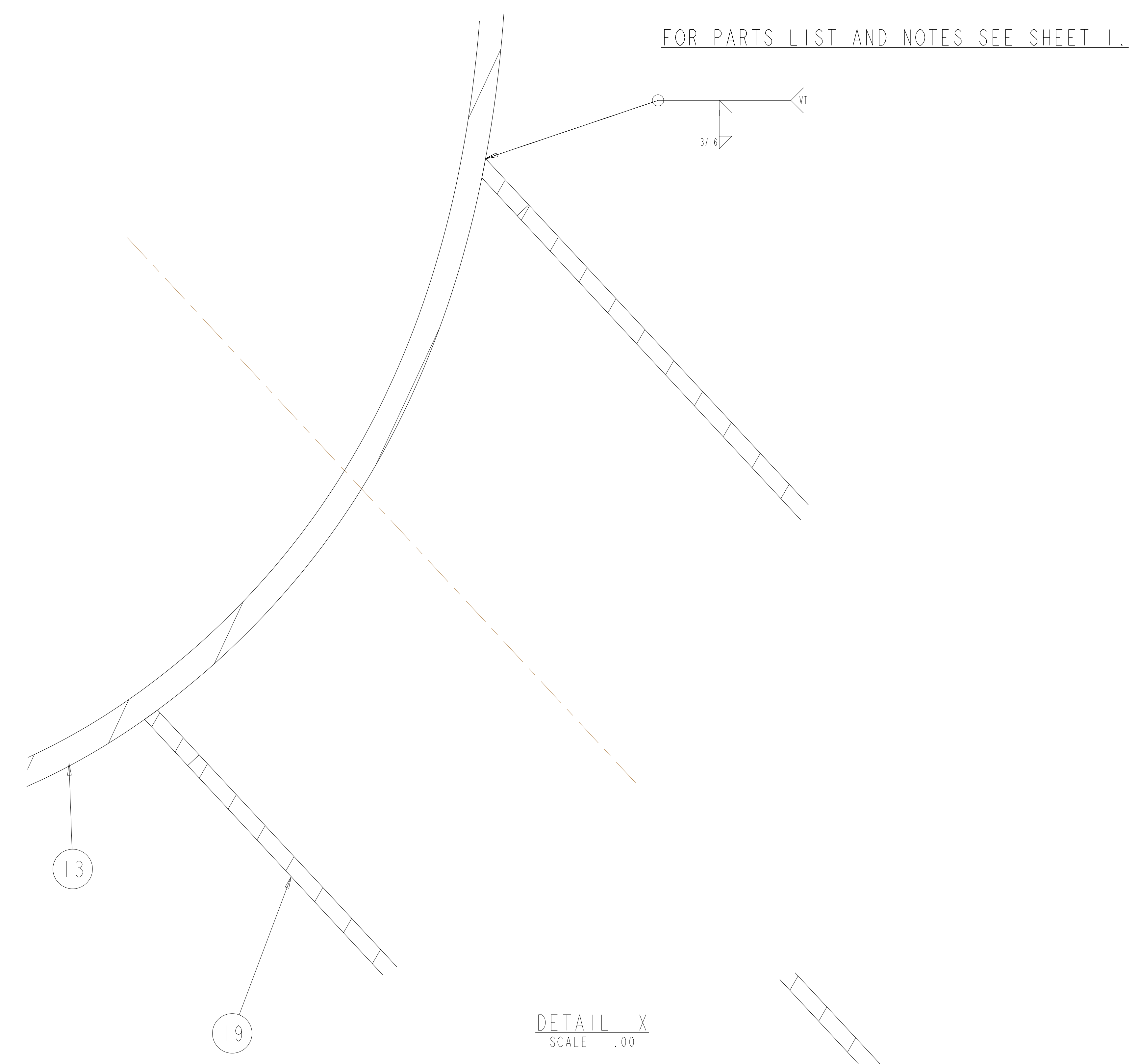

**RELEASED FOR  
 FABRICATION / INSTALLATION**  
 PPPL Drafting:

<b>UT-BATTELLE</b>		Oak Ridge National Laboratory managed for the DEPARTMENT OF ENERGY under U.S. GOVERNMENT contract DE-AC05-00OR22725 UT-BATTELLE, LLC, Oak Ridge, Tennessee					
NATIONAL COMPACT STELLARATOR EXPERIMENT		PROJECT NAME					
VACUUM VESSEL PERIOD INSPECTION AND LEAK CHECK ASSEMBLY		CLASS					
VERSION NO. 5	PLANT X-10	BLDG 5700	FL 3	SHT OF 7	TYPE 19	CLASS A	REV U
RELEASE LEVEL Fabrication		SE120-004				REV 2	

H  
G  
F  
E  
D  
C  
B  
A

FOR PARTS LIST AND NOTES SEE SHEET 1.

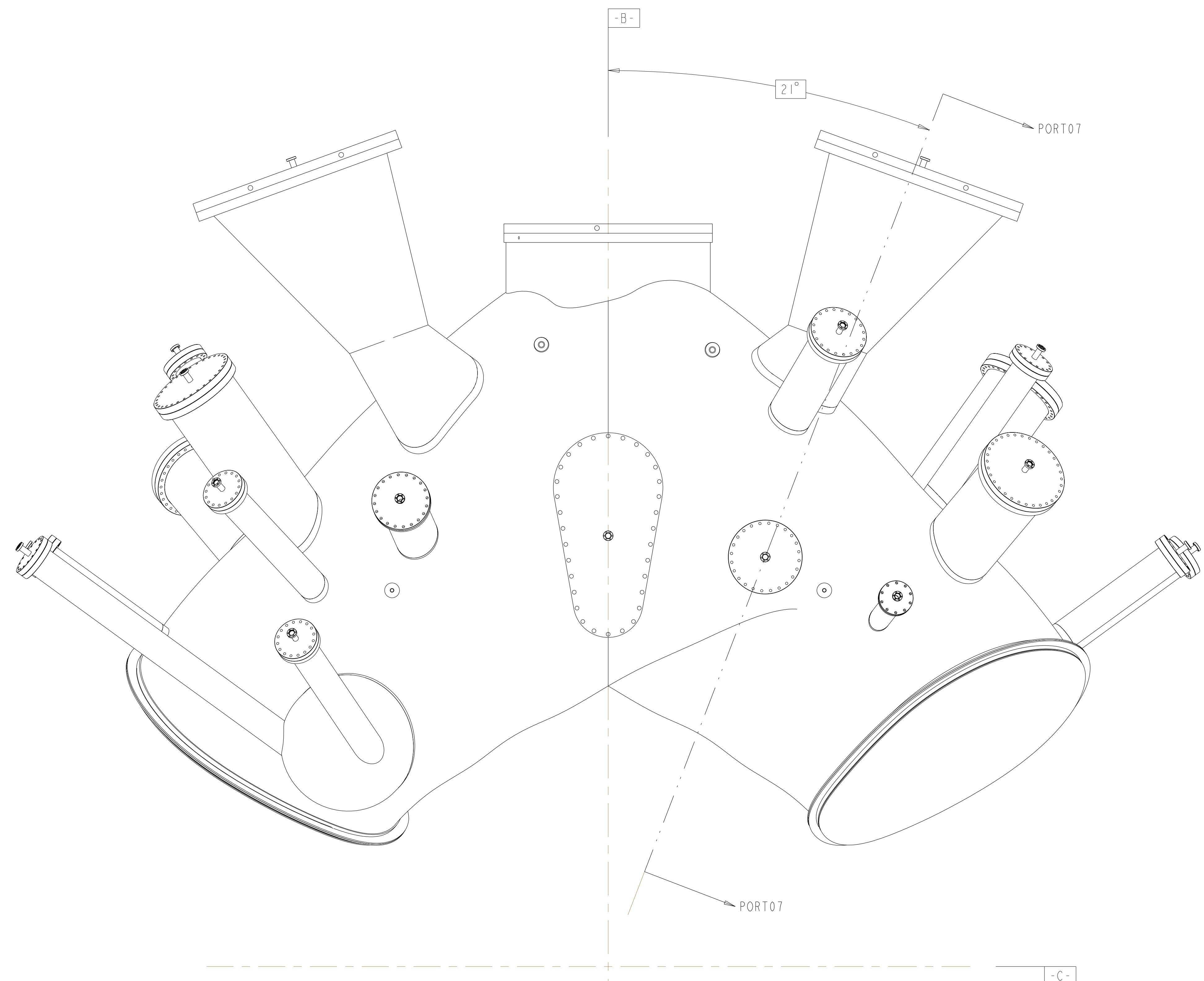

BOTTOM VIEW

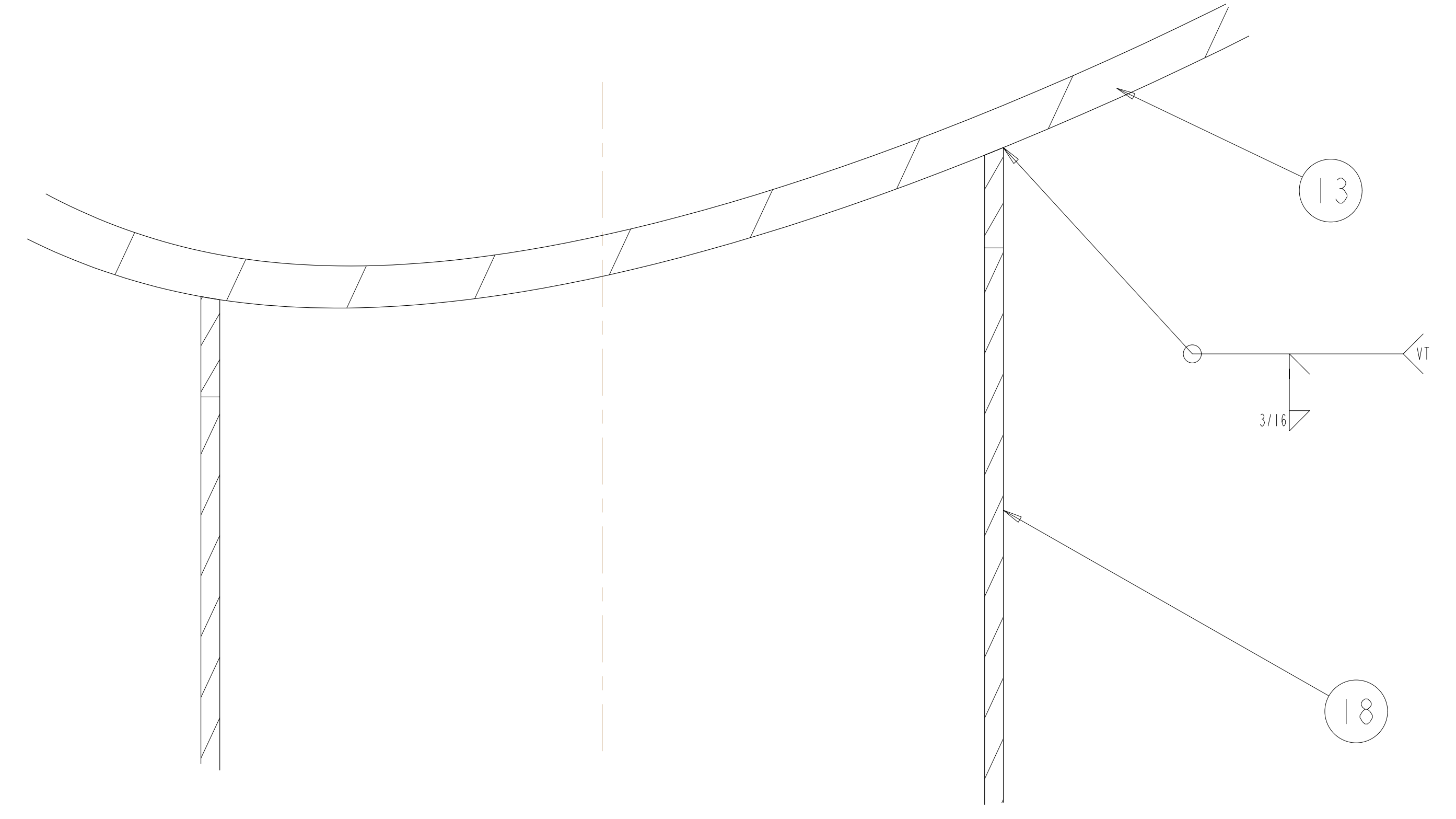

DETAIL X  
SCALE 1.00

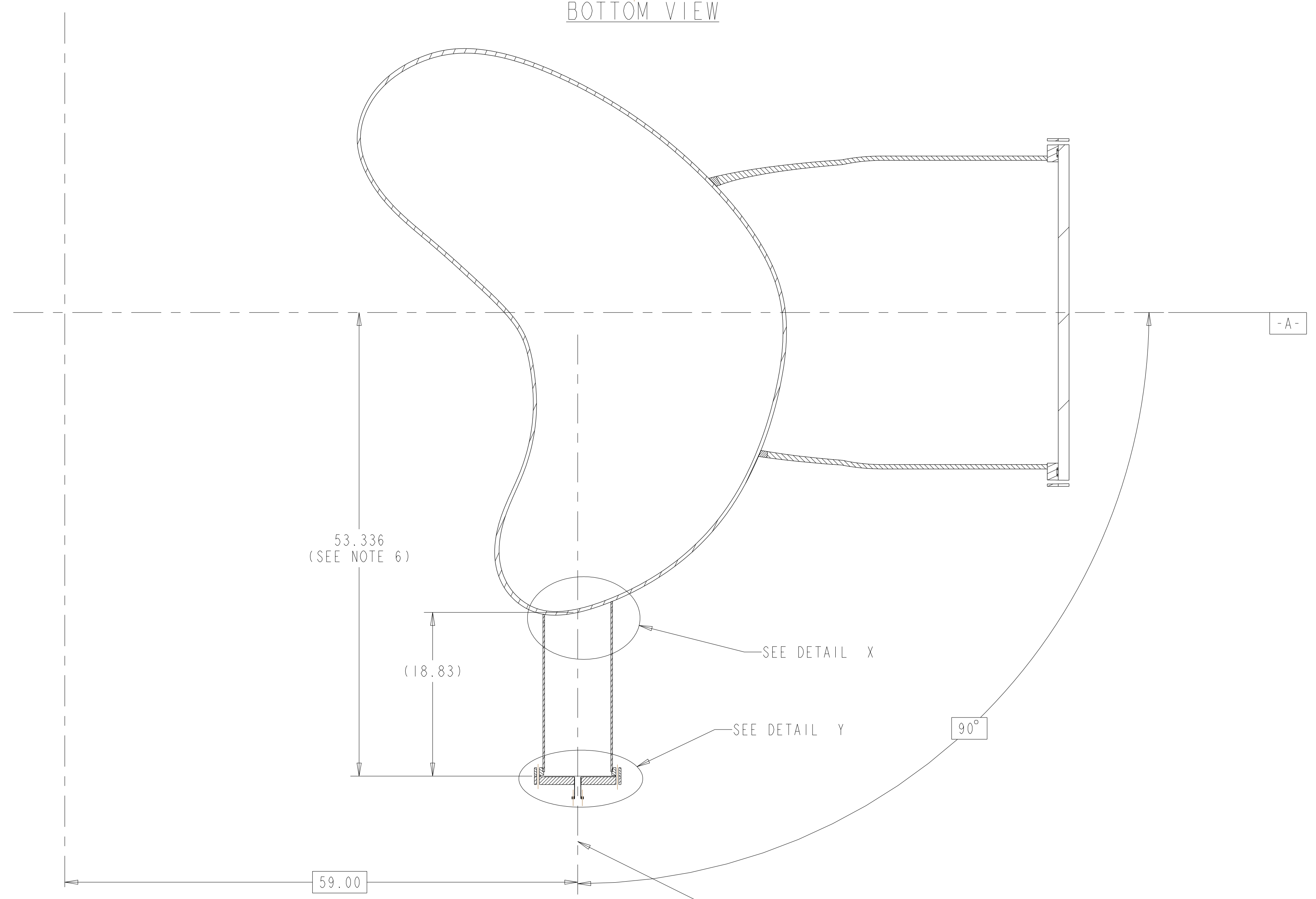

TYPICAL PORT 7A AND 7B  
SECTION PORT07-PORT07

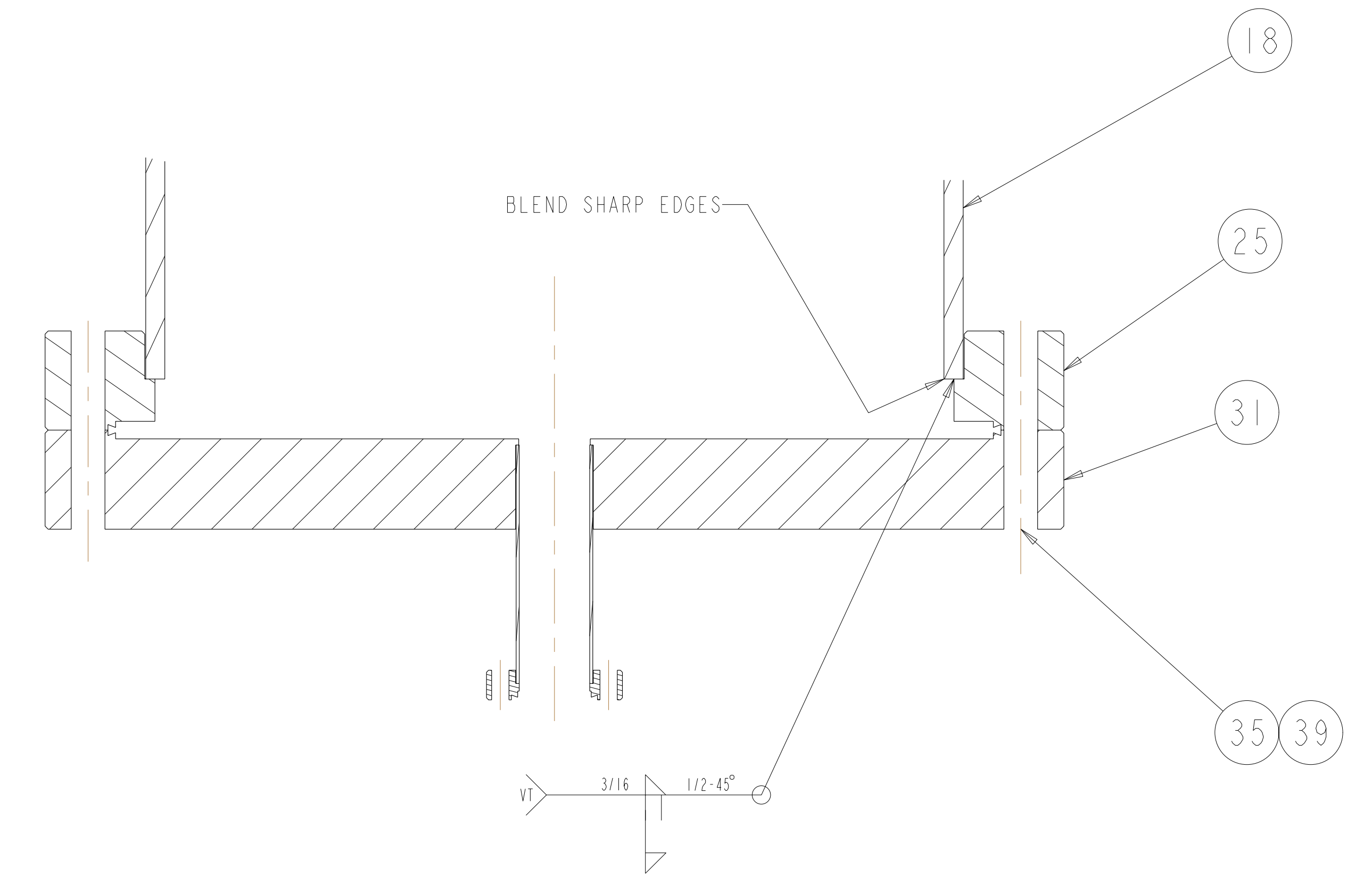

DETAIL Y  
SCALE 1.00

**RELEASED FOR  
FABRICATION / INSTALLATION**  
 PPPL Drafting:

UT-BATTELLE		Oak Ridge National Laboratory managed for the DEPARTMENT OF ENERGY under U.S. GOVERNMENT contract DE-AC05-00OR22725 UT-BATTELLE, LLC, Oak Ridge, Tennessee	
PROJECT NAME			
NATIONAL COMPACT STELLARATOR EXPERIMENT			
VACUUM VESSEL PERIOD INSPECTION AND LEAK CHECK ASSEMBLY			
VERSION NO.	PLANT	BLDG	FL SHT OF TYPE CLASS
5	X-10	5700	3 8 19 A U
RELEASE LEVEL		REV	
Fabrication		2	

SE120-004



FOR PARTS LIST AND NOTES SEE SHEET 1.

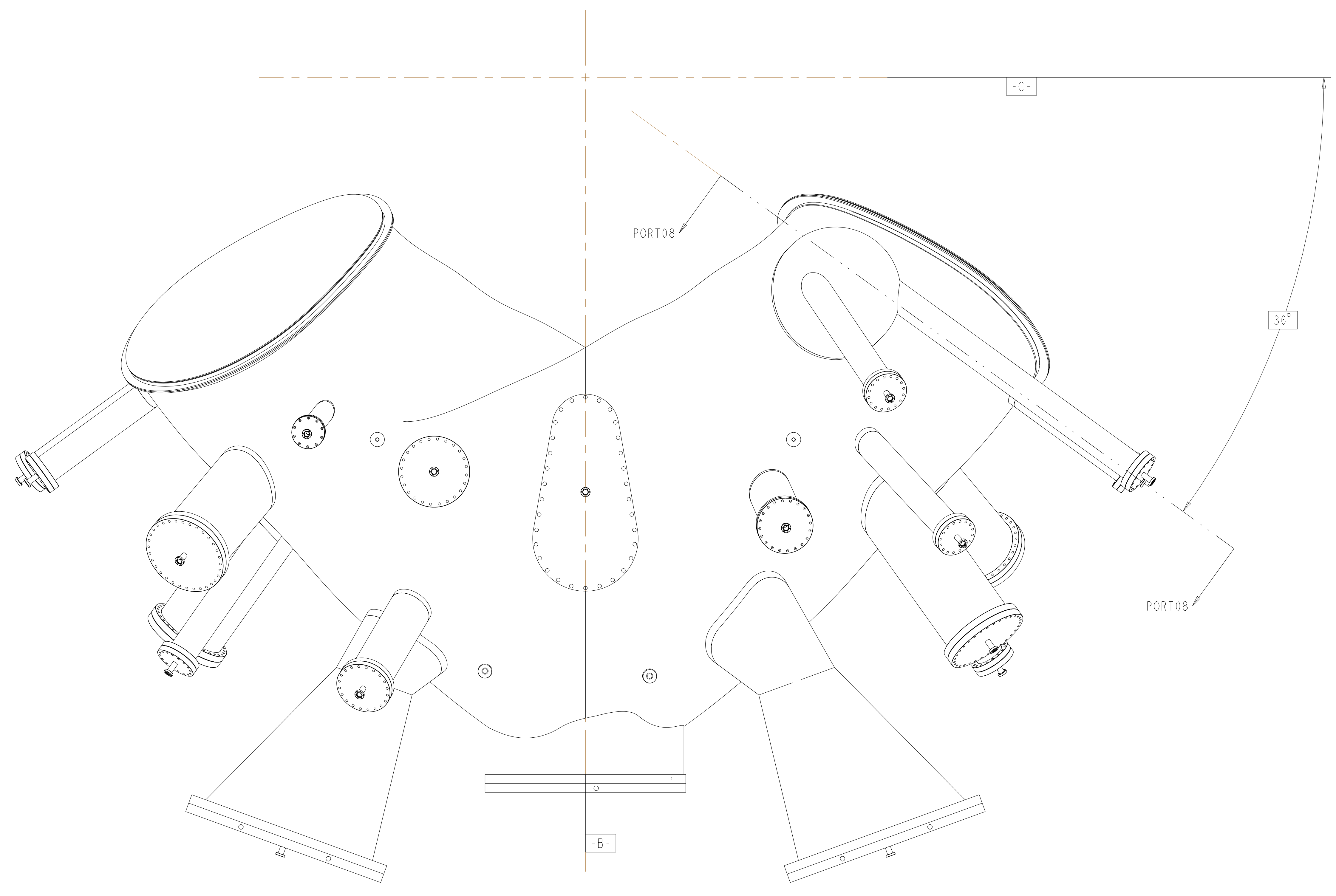

TOP VIEW

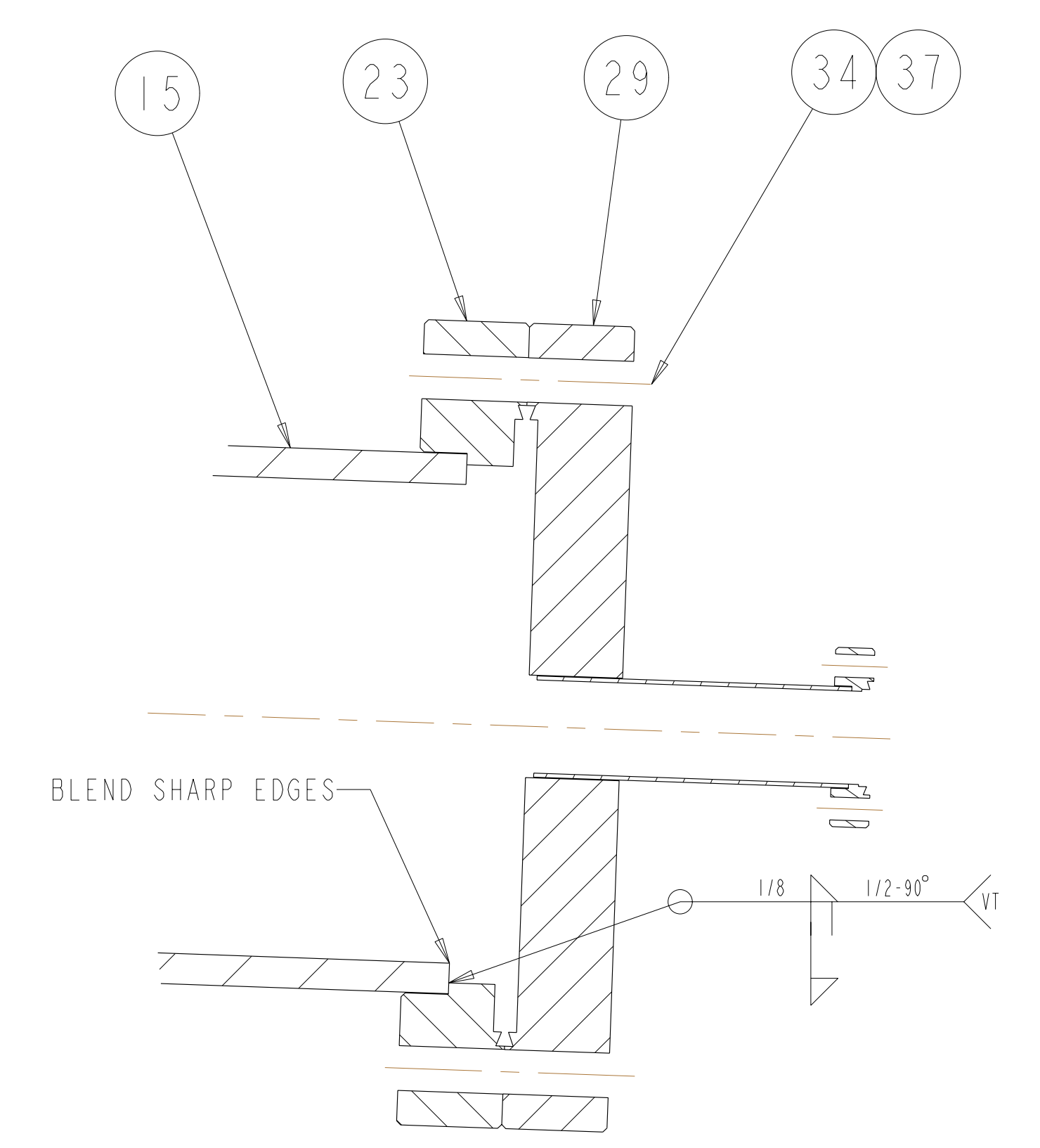

DETAIL Y  
 SCALE 1.00

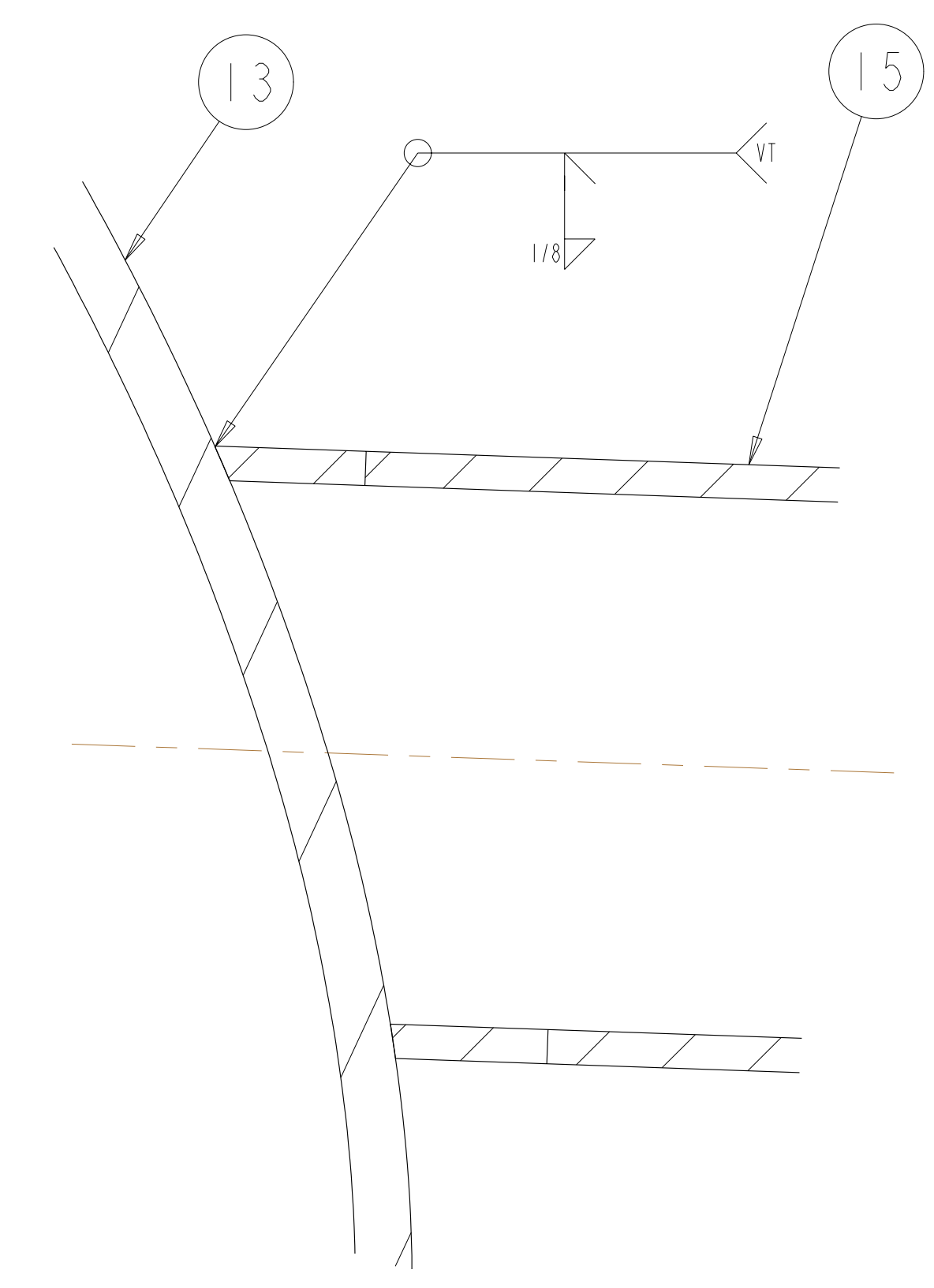

DETAIL X  
 SCALE 1.00

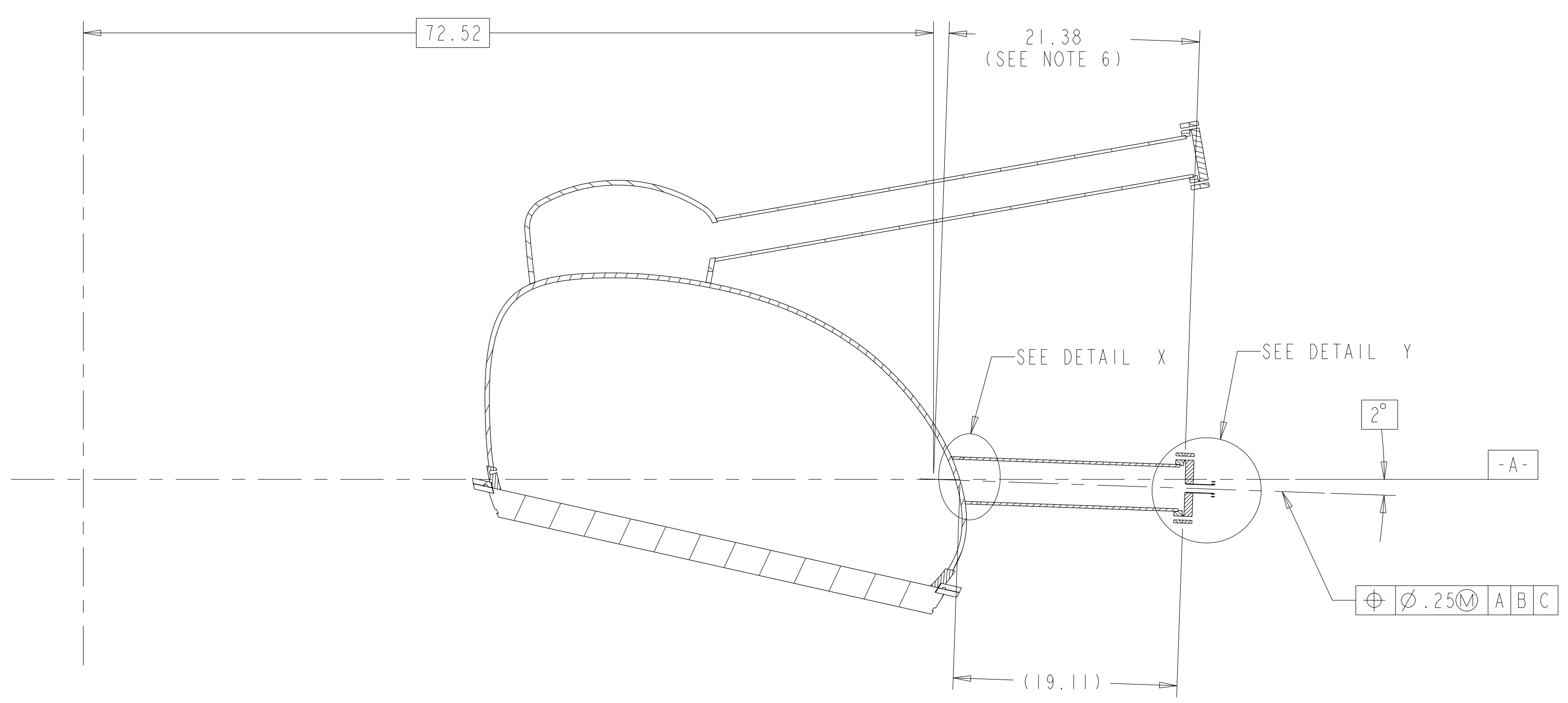

TYPICAL PORT 8A AND 8B  
 SECTION PORT08-PORT08

**RELEASED FOR  
 FABRICATION / INSTALLATION**  
 PPPL Drafting:

Oak Ridge National Laboratory managed for the DEPARTMENT OF ENERGY under U.S. GOVERNMENT contract DE-AC05-00OR22725 UT-BATTELLE, LLC., Oak Ridge, Tennessee PROJECT NAME						
NATIONAL COMPACT STELLERATOR EXPERIMENT VACUUM VESSEL PERIOD INSPECTION AND LEAK CHECK ASSEMBLY						
VERSION NO.	PLANT	BLDG	FL	SHT OF	TYPE	CLASS
5	X-10	5700	3	9 19	A	U
RELEASE LEVEL	SE120-004					REV
Fabrication						2

SE120-004

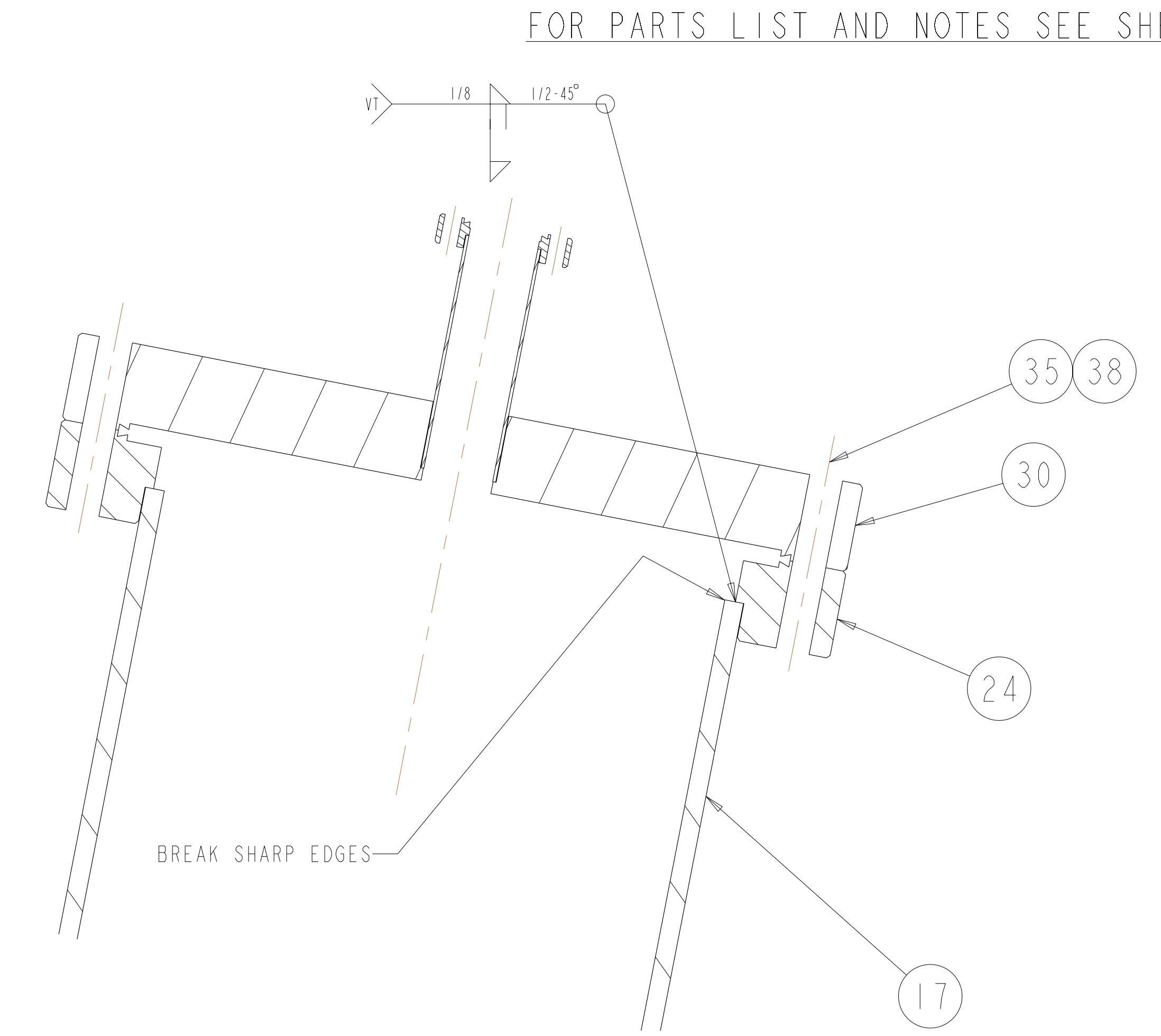
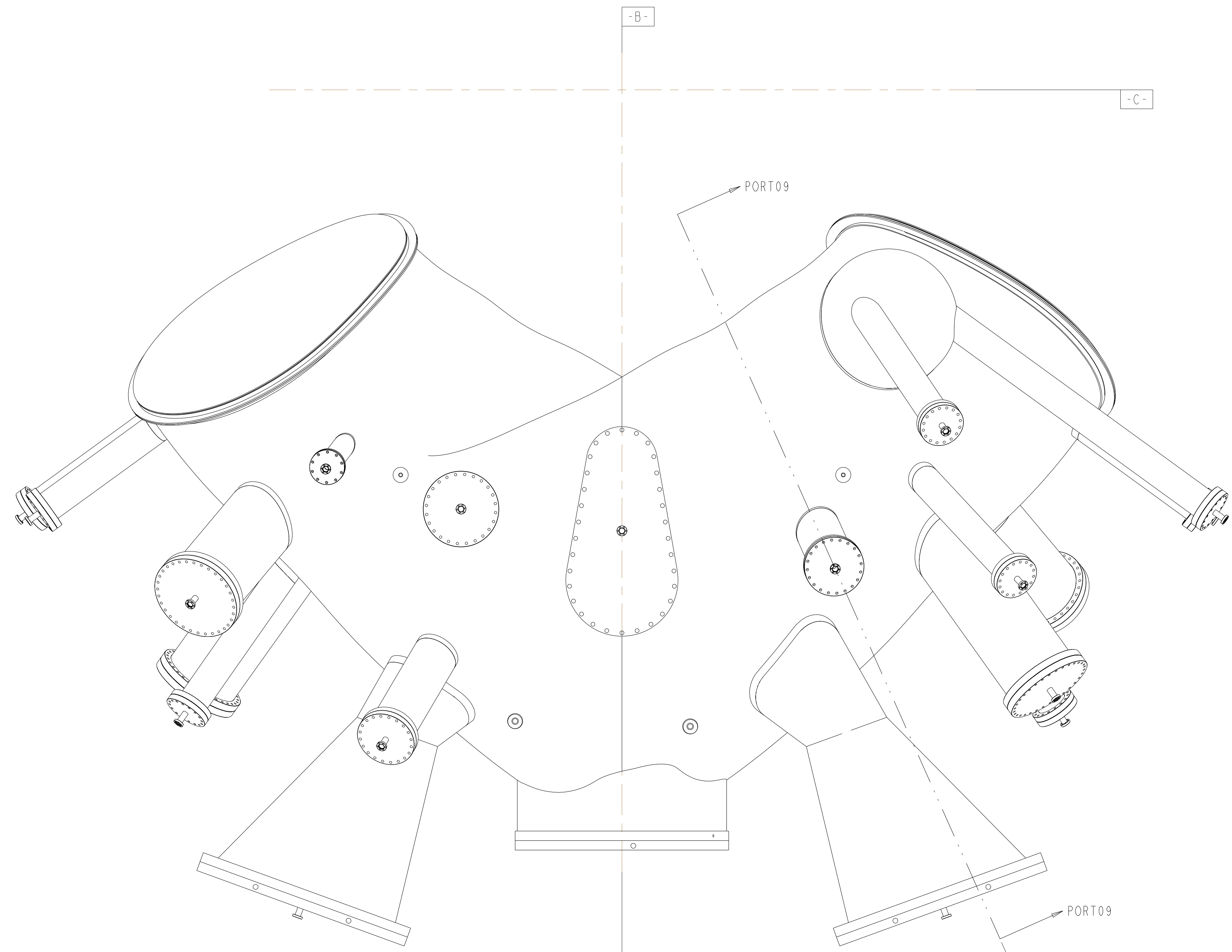

DETAIL Y  
 SCALE 1.00

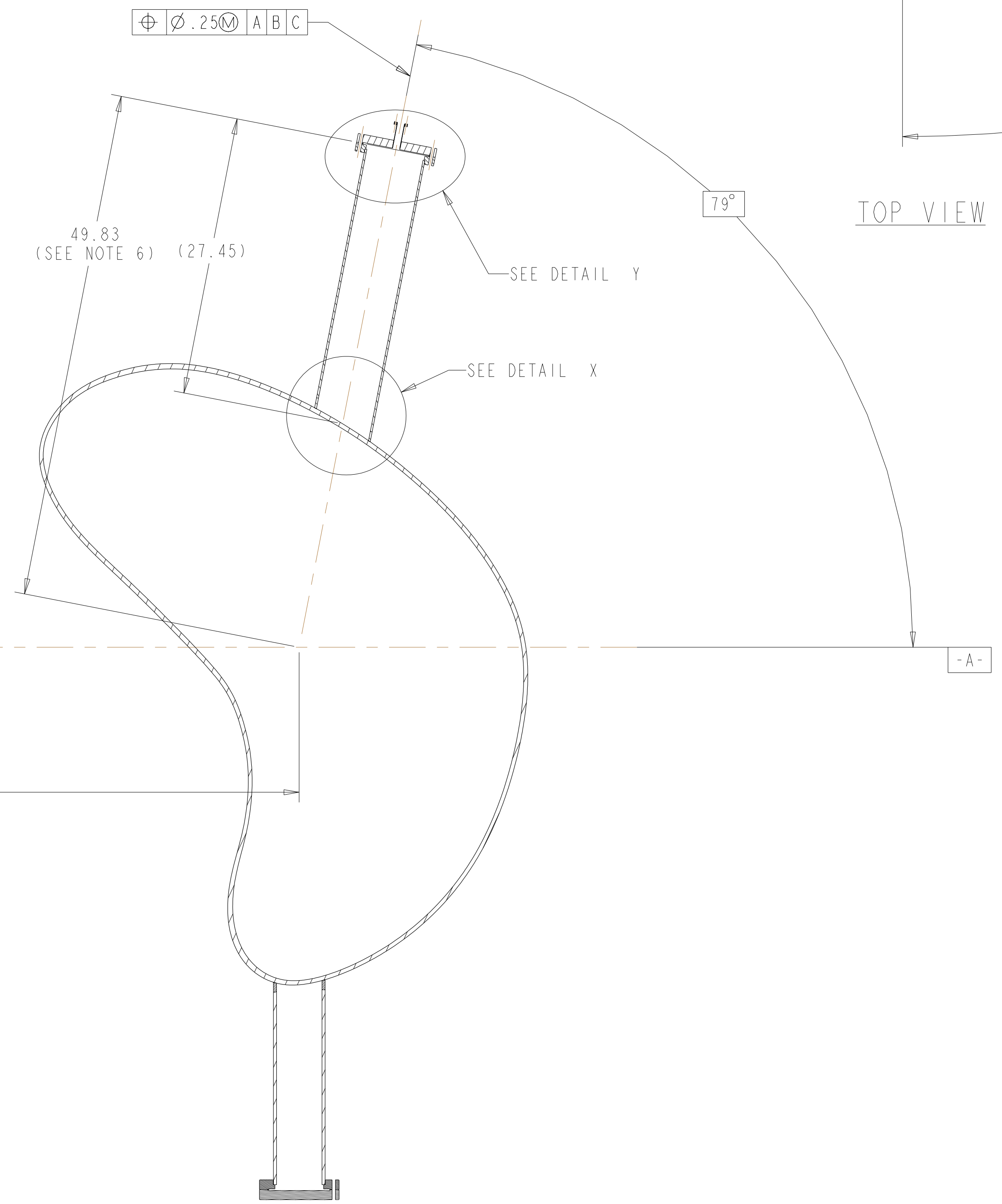

TYPICAL PORT 9A AND 9B  
 SECTION PORT09-PORT09

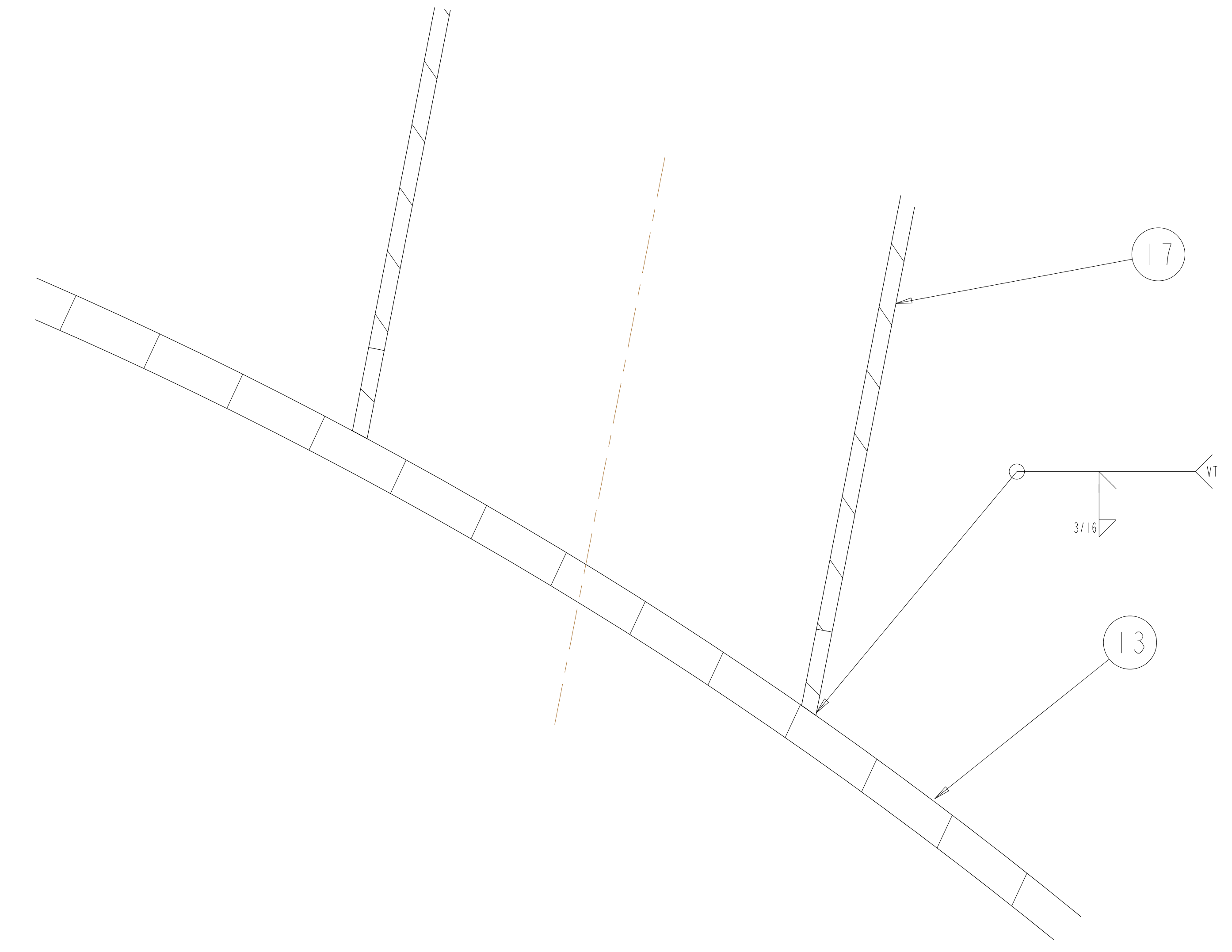

**RELEASED FOR  
 FABRICATION / INSTALLATION**  
 PPPL Drafting:

<b>UT-BATTELLE</b>		Oak Ridge National Laboratory managed for the DEPARTMENT OF ENERGY under U.S. GOVERNMENT contract DE-AC05-00OR22725 UT-BATTELLE, LLC, Oak Ridge, Tennessee					
PROJECT NAME							
NATIONAL COMPACT STELLARATOR EXPERIMENT							
VACUUM VESSEL PERIOD INSPECTION AND LEAK CHECK ASSEMBLY							
VERSION NO.	PLANT	BLDG	FL	SHT OF	TYPE	CLASS	
5	X-10	5700	3	10	19	A	
RELEASE LEVEL		SE120-004			REV		
Fabrication					U 2		

H  
G  
F  
E  
D  
C  
B  
A

FOR PARTS LIST AND NOTES SEE SHEET 1.

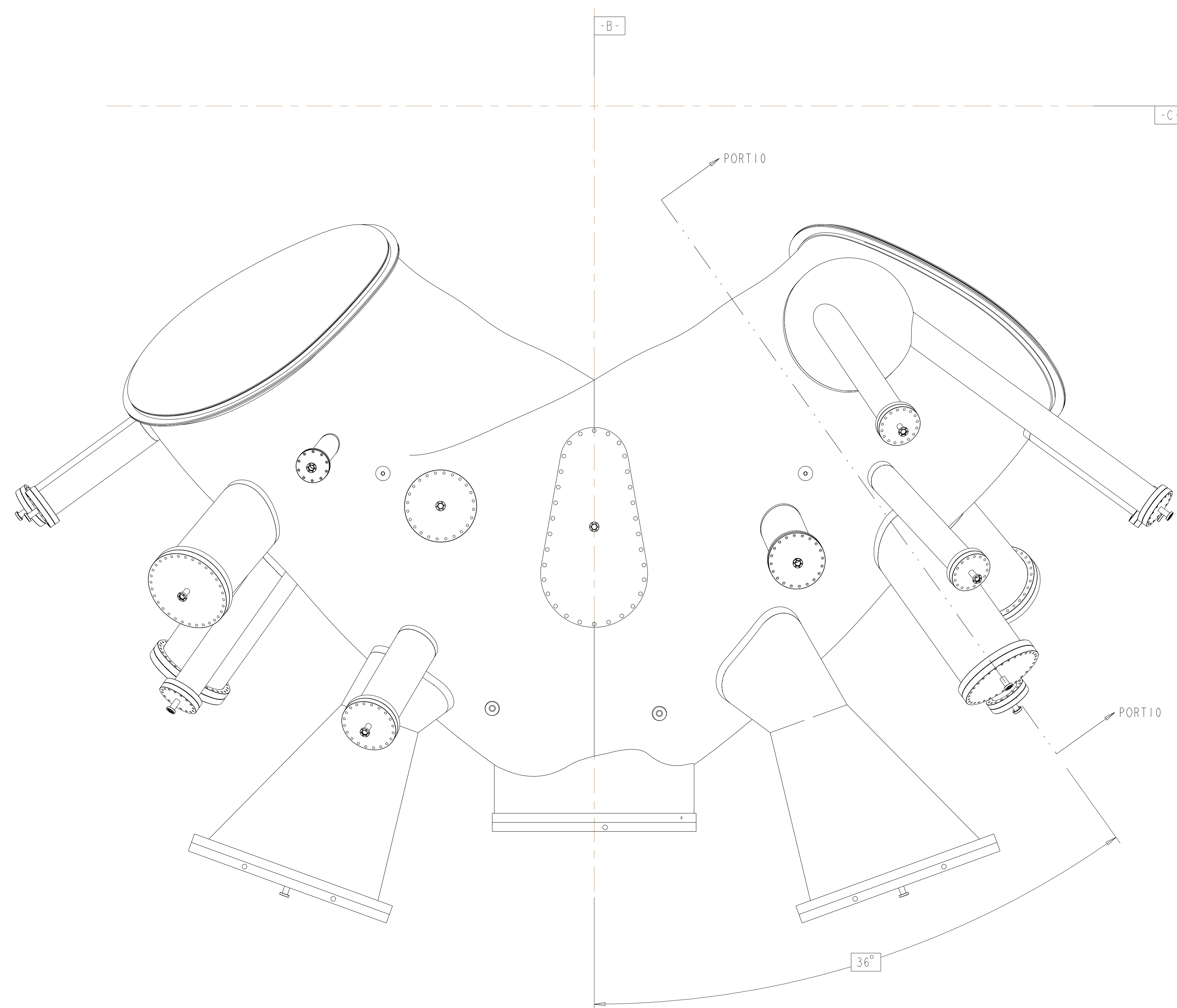

TOP VIEW

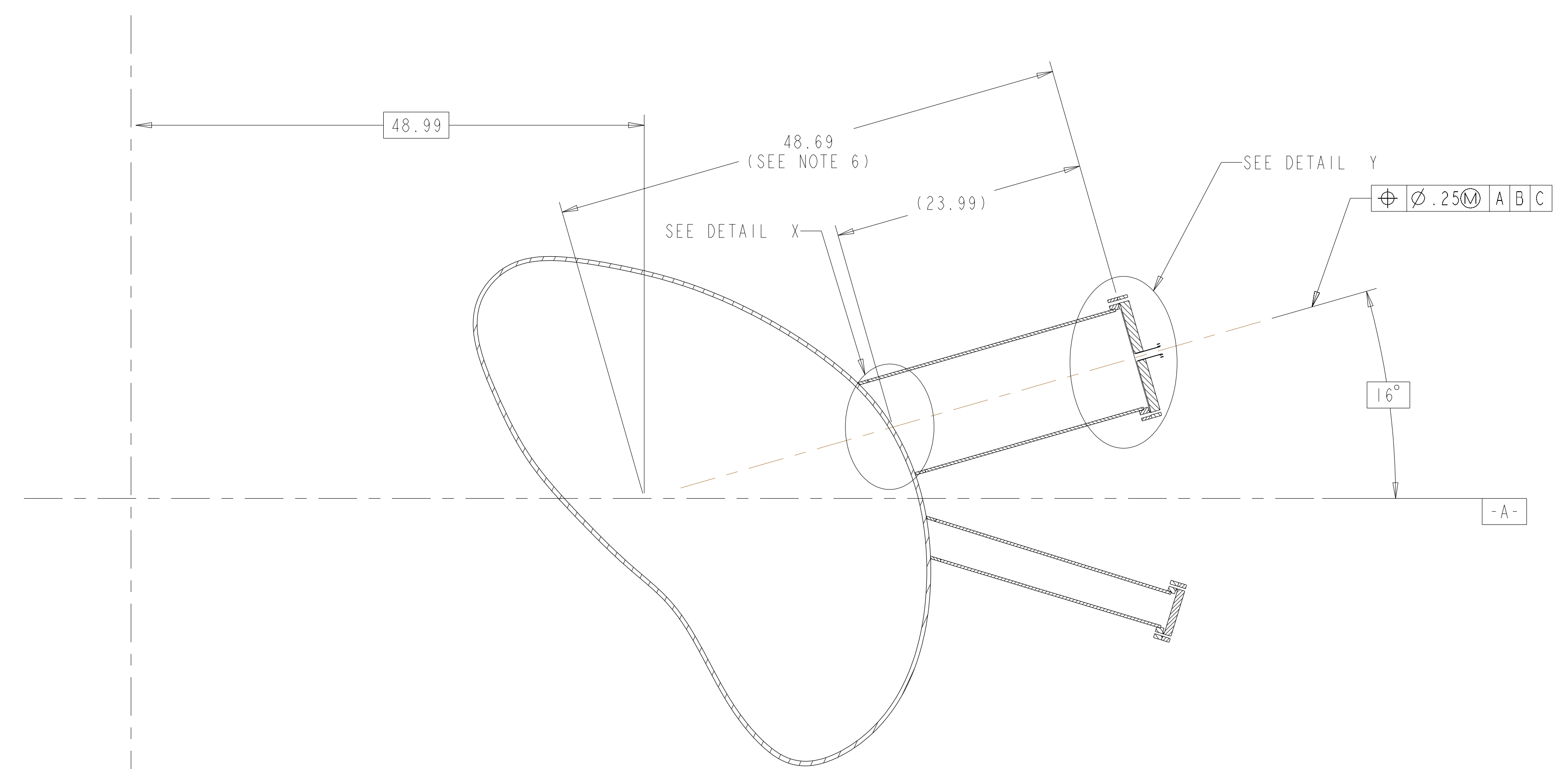

TYPICAL PORT 10A AND 10B  
 SECTION PORT10-PORT10

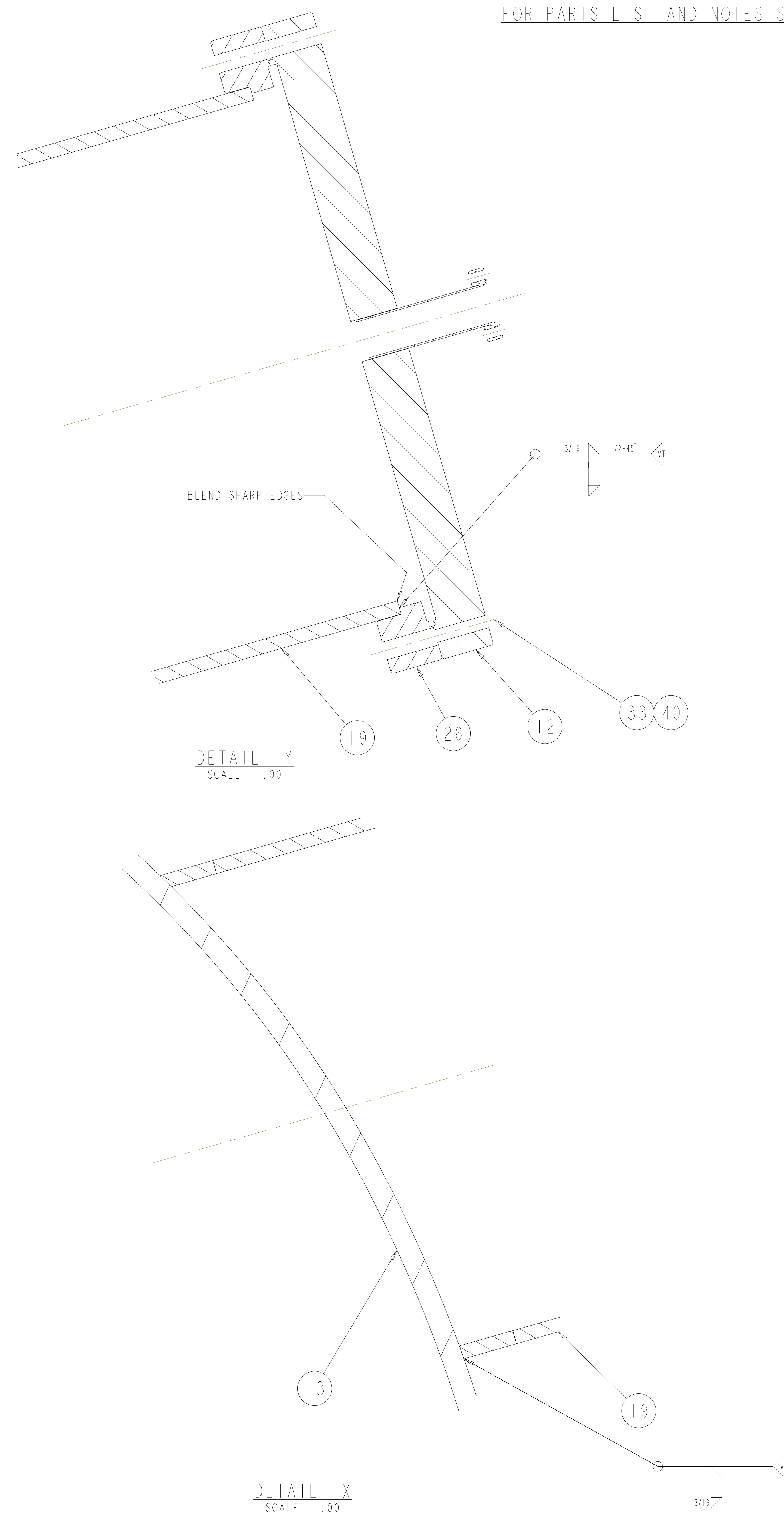

DETAIL Y  
 SCALE 1.00

DETAIL X  
 SCALE 1.00

**RELEASED FOR  
 FABRICATION / INSTALLATION**  
 PPPL Drafting:

<b>UT-BATTELLE</b>		Oak Ridge National Laboratory managed for the DEPARTMENT OF ENERGY under U.S. GOVERNMENT contract DE-AC05-00OR22725 UT-BATTELLE, LLC, Oak Ridge, Tennessee					
NATIONAL COMPACT STELLARATOR EXPERIMENT		PROJECT NAME					
VACUUM VESSEL		PERIOD INSPECTION AND LEAK CHECK					
ASSEMBLY		CLASS					
VERSION NO. 5	PLANT X-10	BLDG 5700	FL 3	SHT OF 11	TYPE 19	CLASS A	REV U
RELEASE LEVEL Fabrication		SE120-004				REV 2	

H  
G  
F  
E  
D  
C  
B  
A

SE120-004

FOR PARTS LIST AND NOTES SEE SHEET 1.

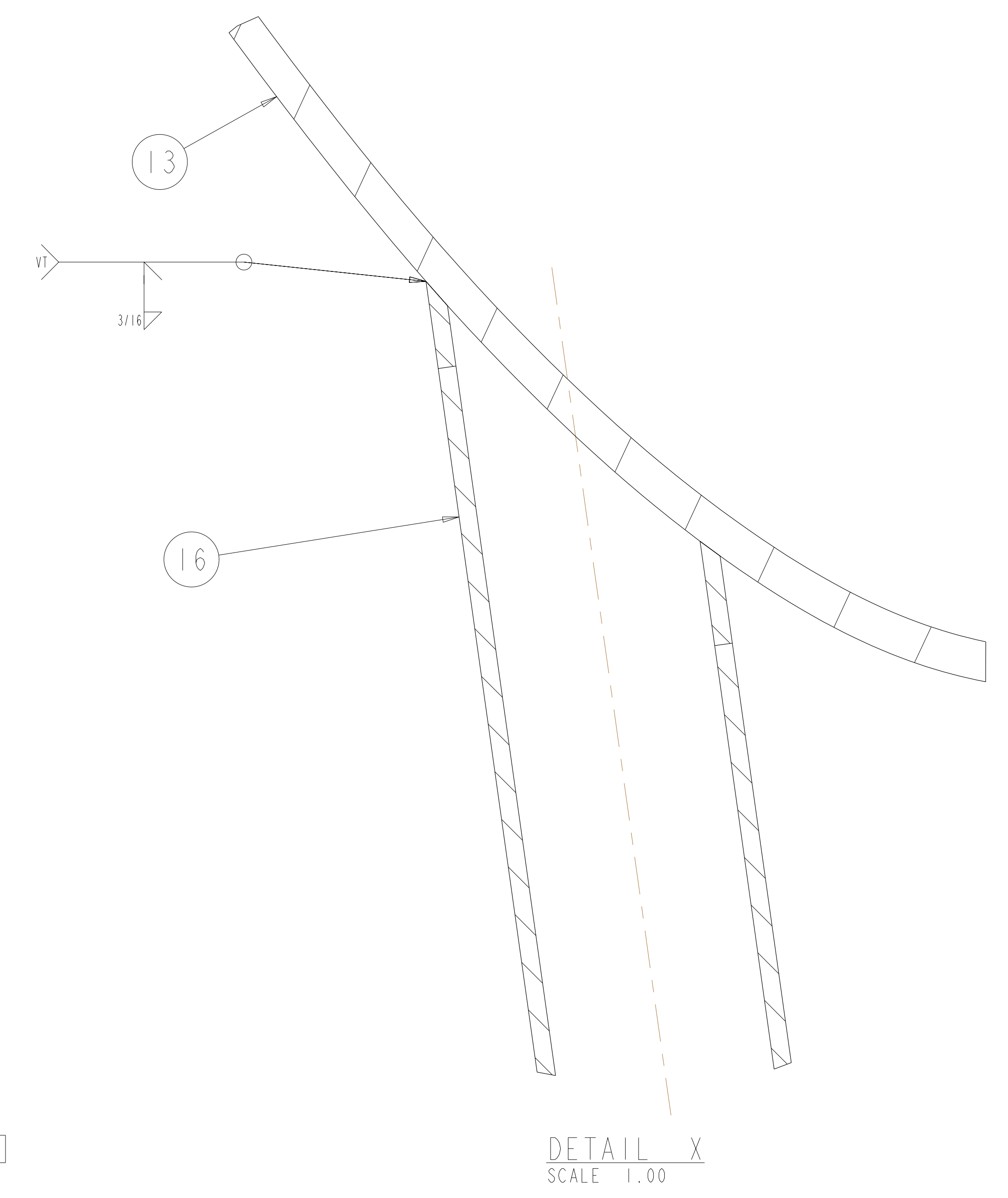
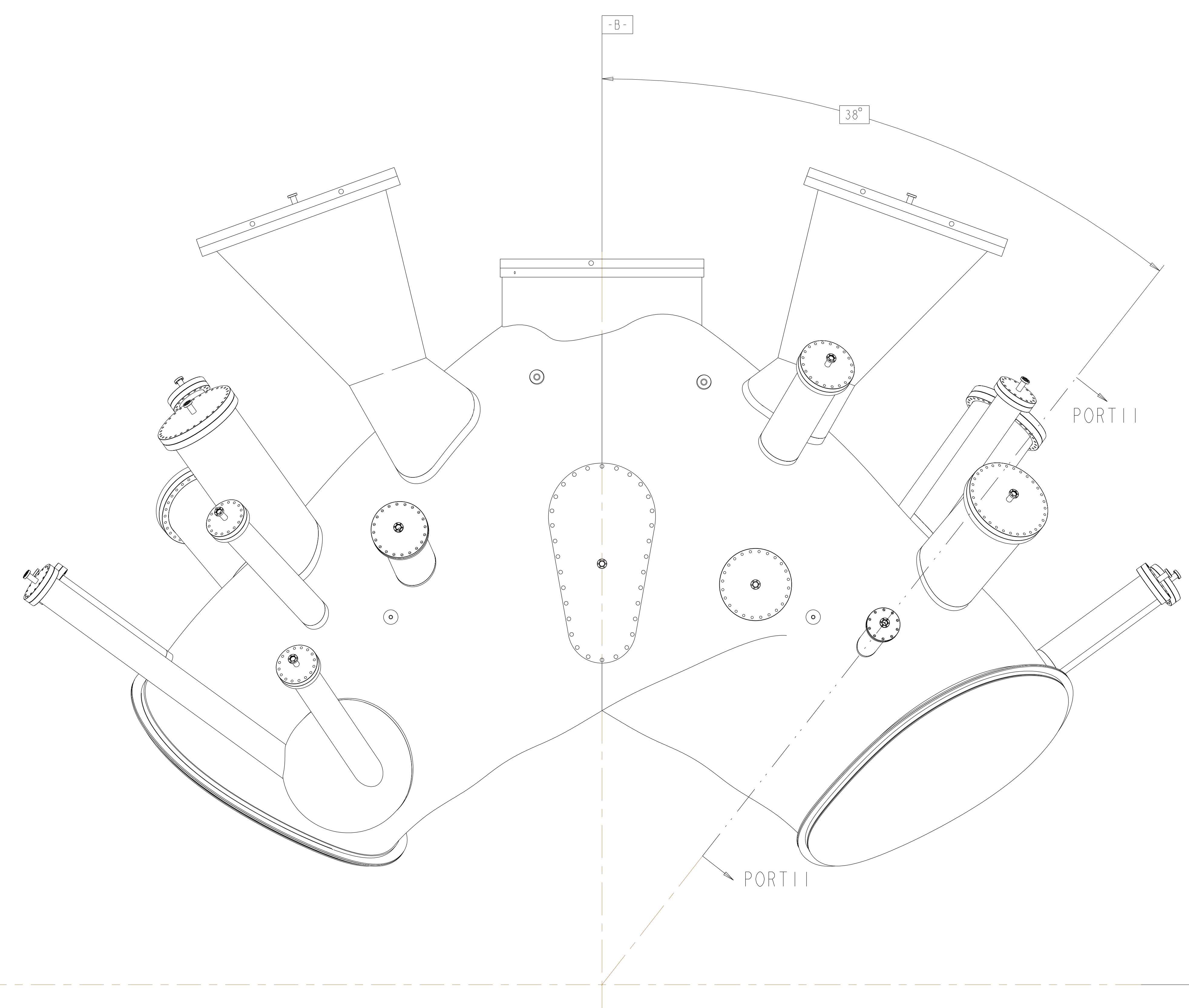

BOTTOM VIEW

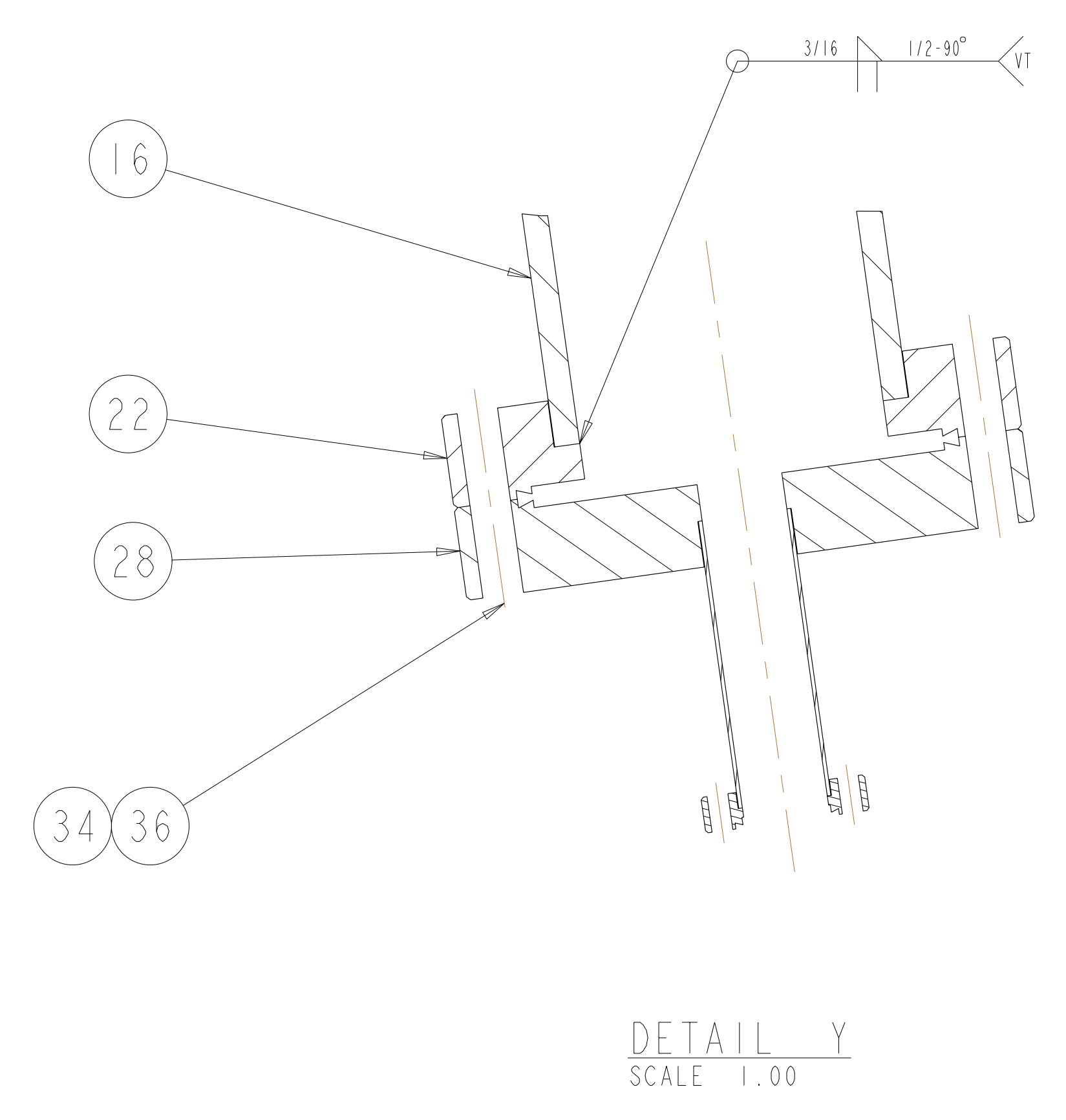
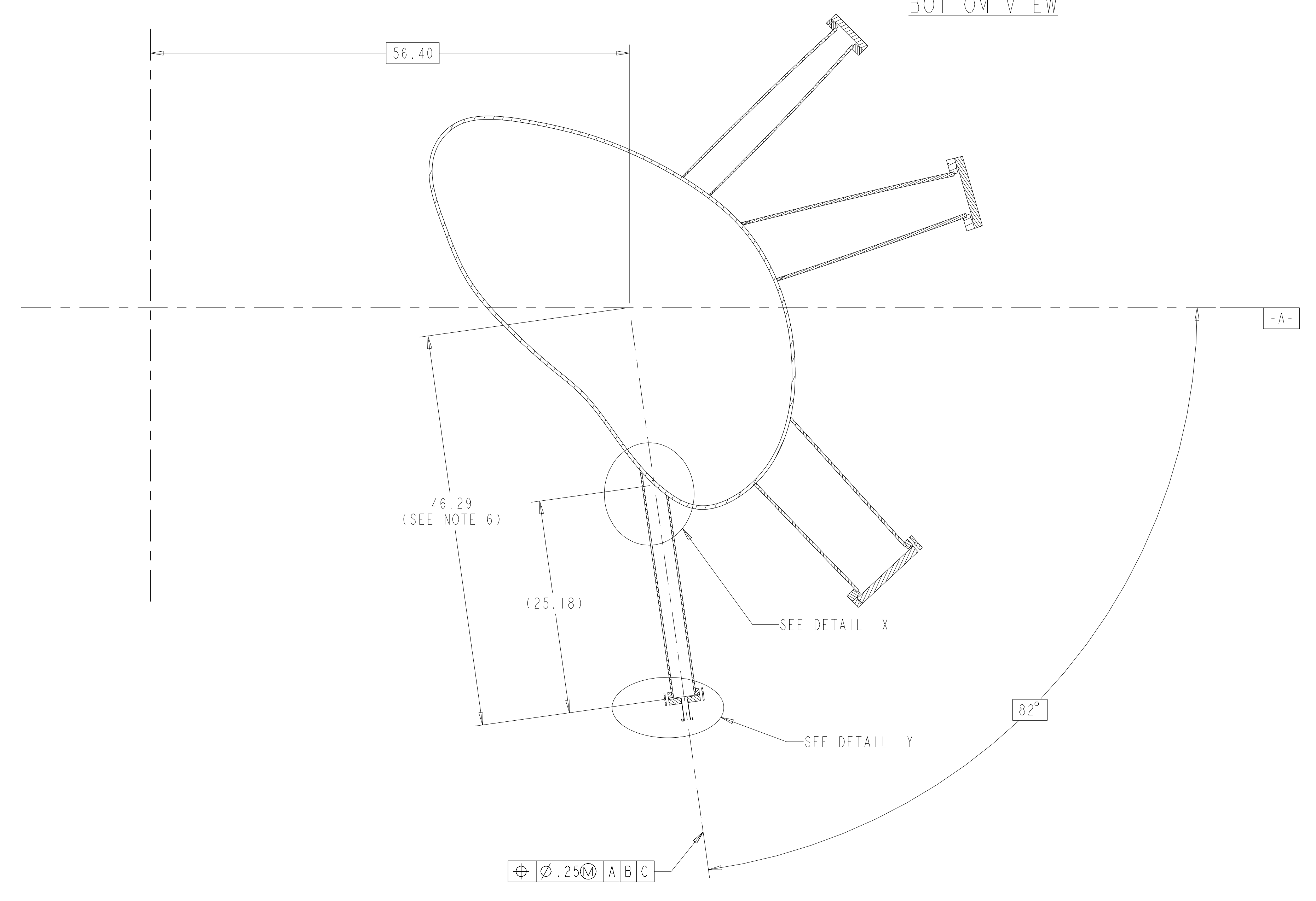

TYPICAL PORT IIA AND IIB SECTION PORT III-PORT III

**RELEASED FOR FABRICATION / INSTALLATION**  
 PPPL Drafting:

UT-BATTELLE		Oak Ridge National Laboratory managed for the DEPARTMENT OF ENERGY under U.S. GOVERNMENT contract DE-AC05-00OR22725 UT-BATTELLE, LLC, Oak Ridge, Tennessee					
NATIONAL COMPACT STELLARATOR EXPERIMENT							
VACUUM VESSEL PERIOD INSPECTION AND LEAK CHECK ASSEMBLY							
VERSION NO. 5	PLANT X-10	BLDG 5700	FL 3	SHT OF 12	TYPE A	CLASS U	
RELEASE LEVEL Fabrication		SE120-004				REV 2	

H  
G  
F  
E  
D  
C  
B  
A

SE120-004

FOR PARTS LIST AND NOTES SEE SHEET 1.

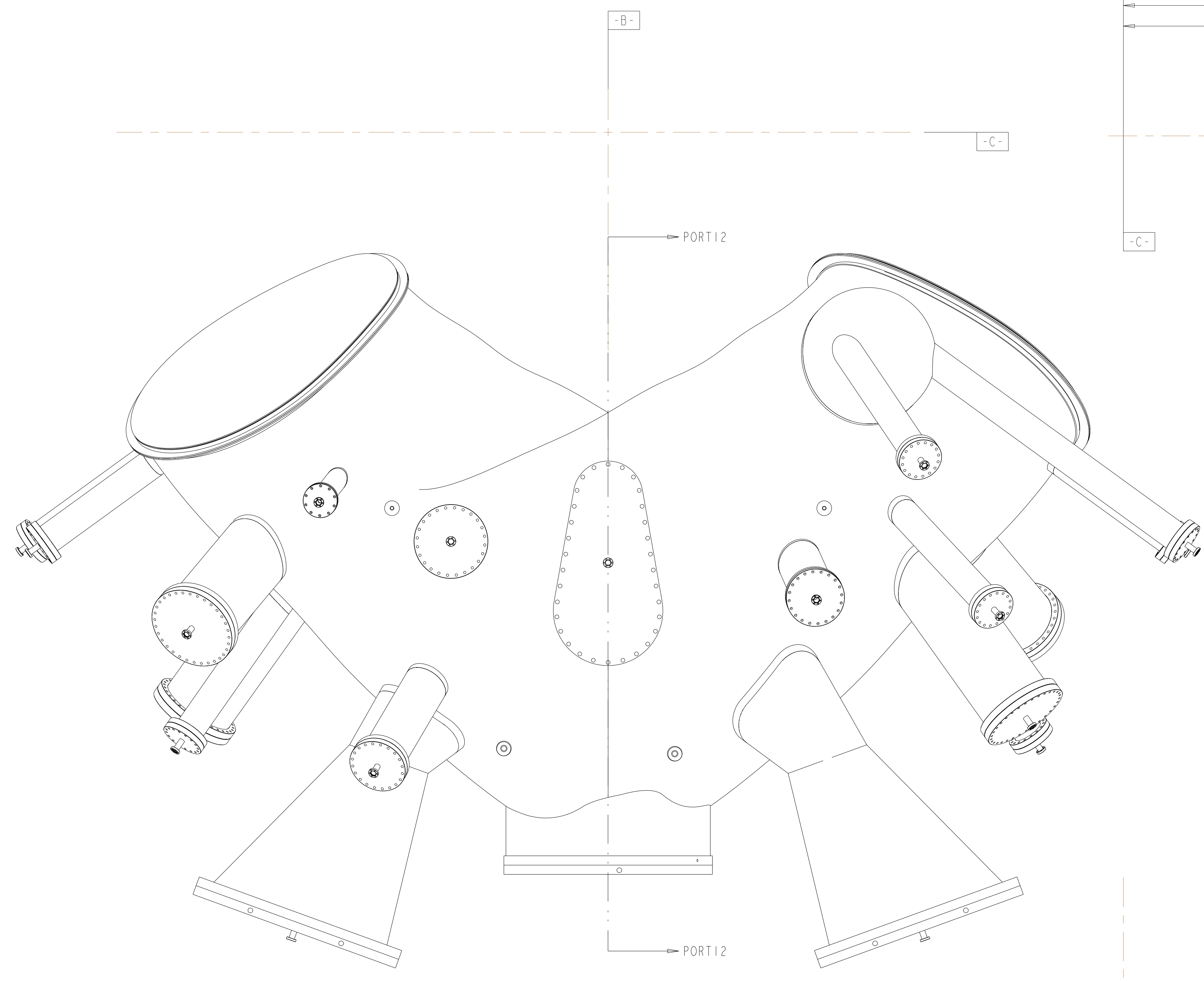

TOP VIEW

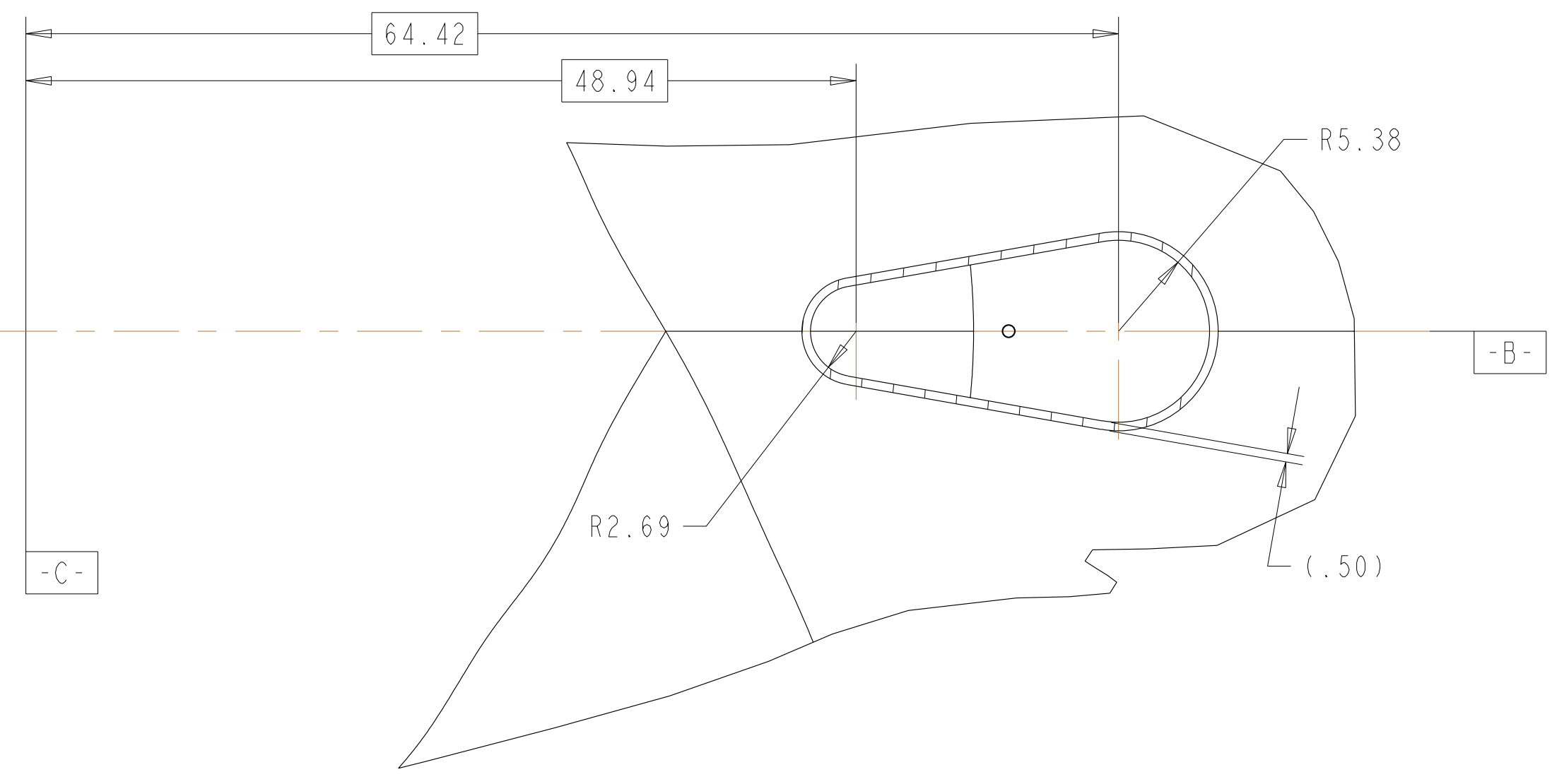

SECTION J-J  
 TYP TOP AND BOTTOM

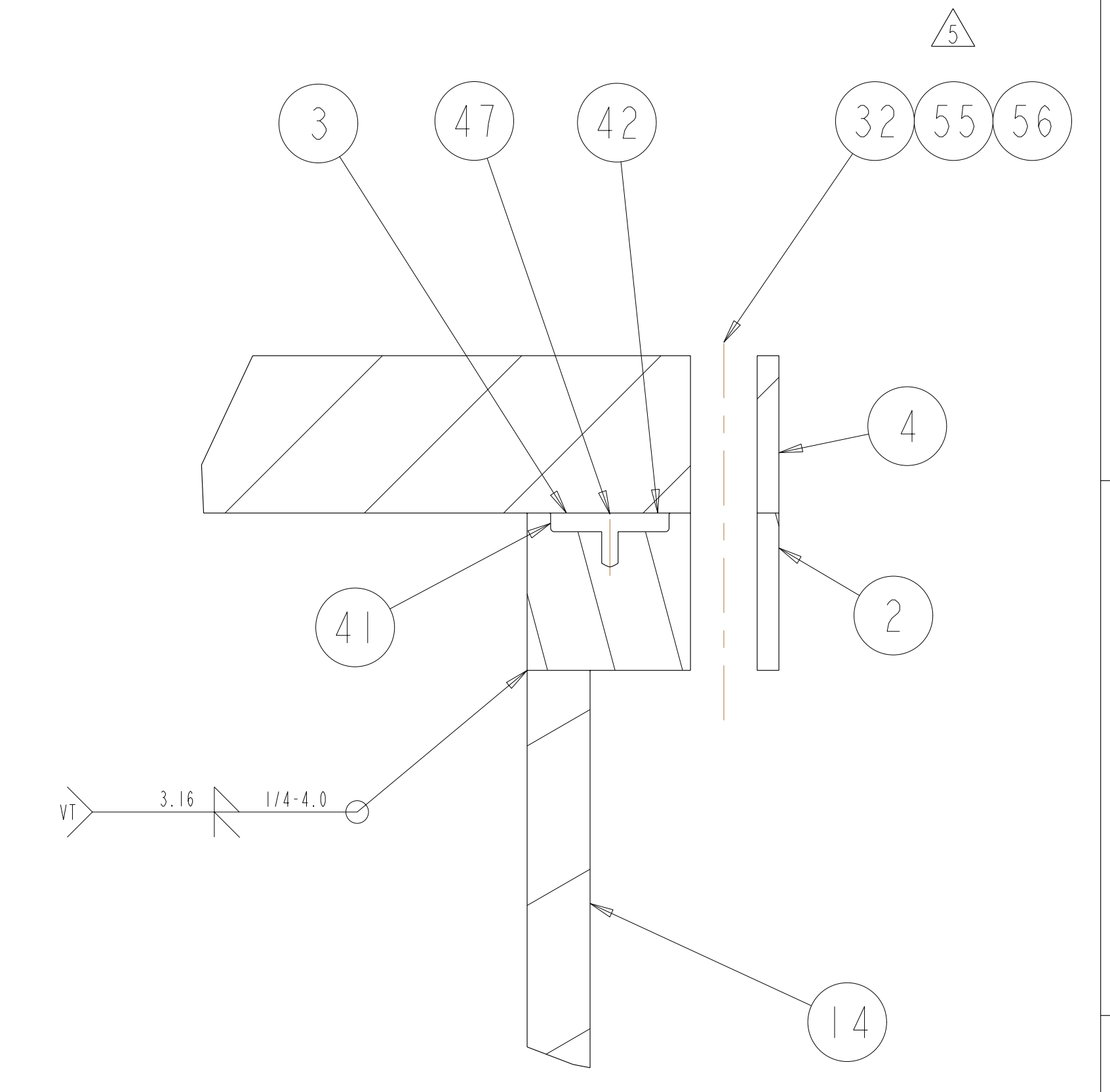

DETAIL Y  
 SCALE 1.00

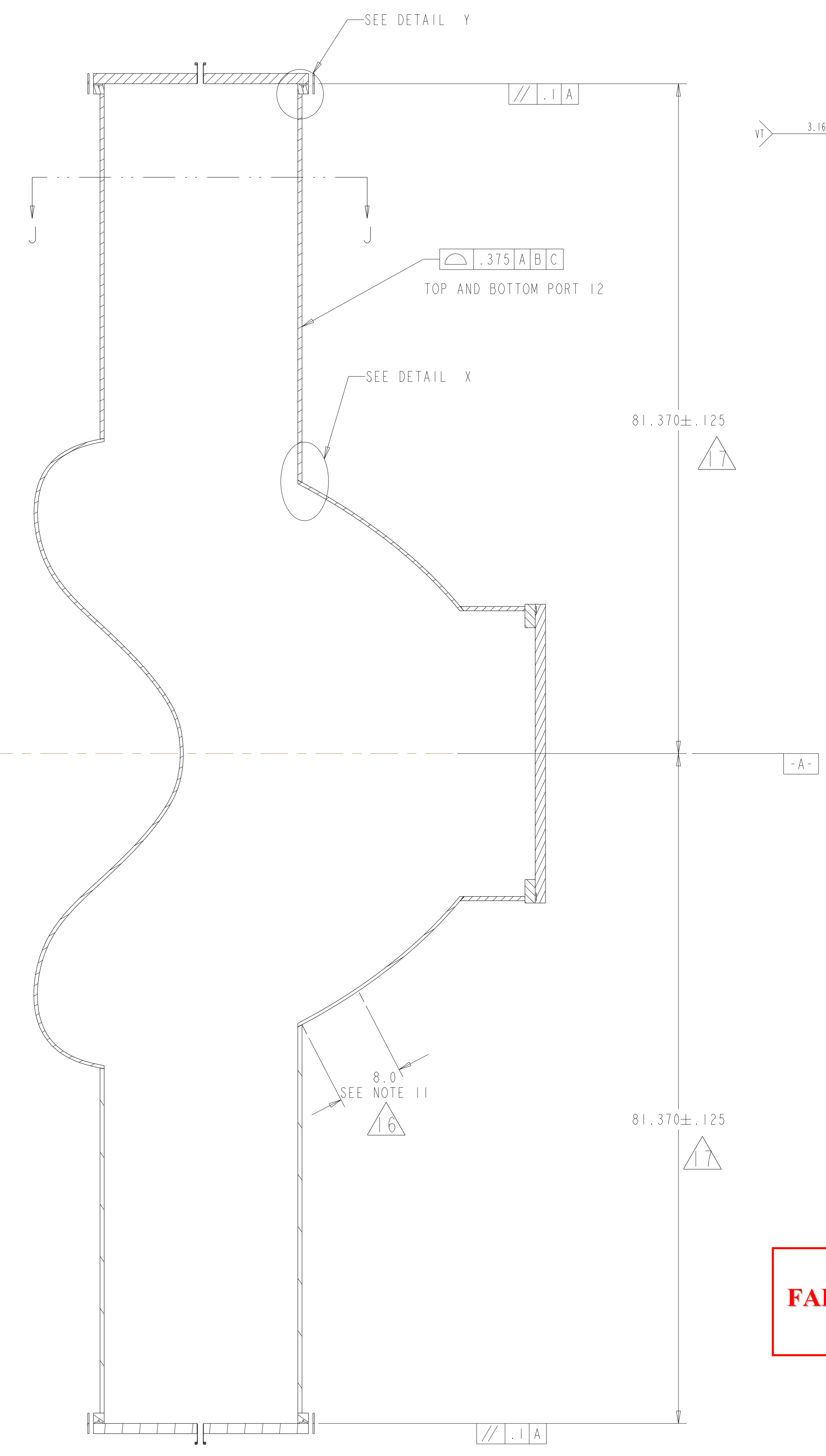

SECTION PORT12-PORT12

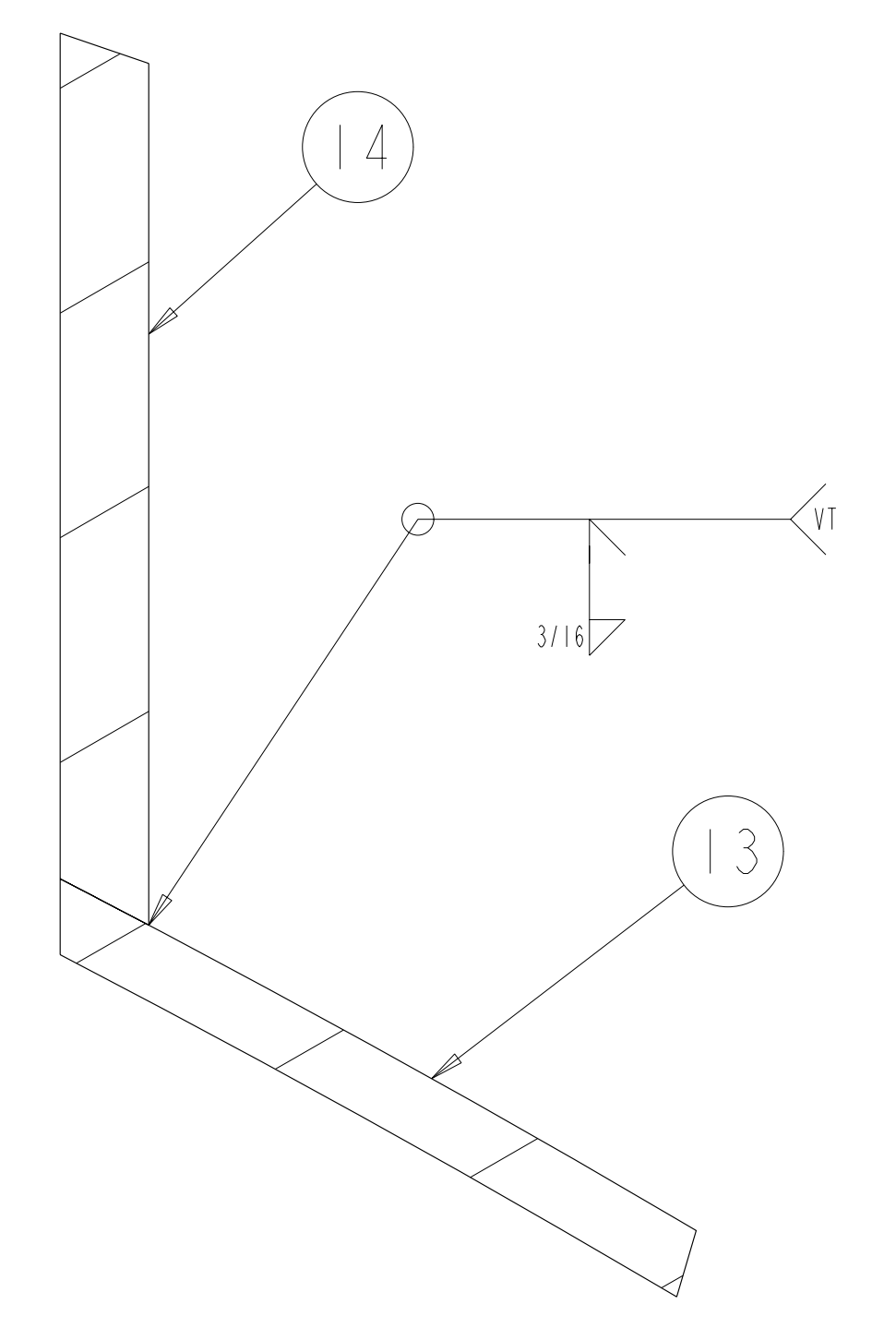

DETAIL X  
 SCALE 1.00

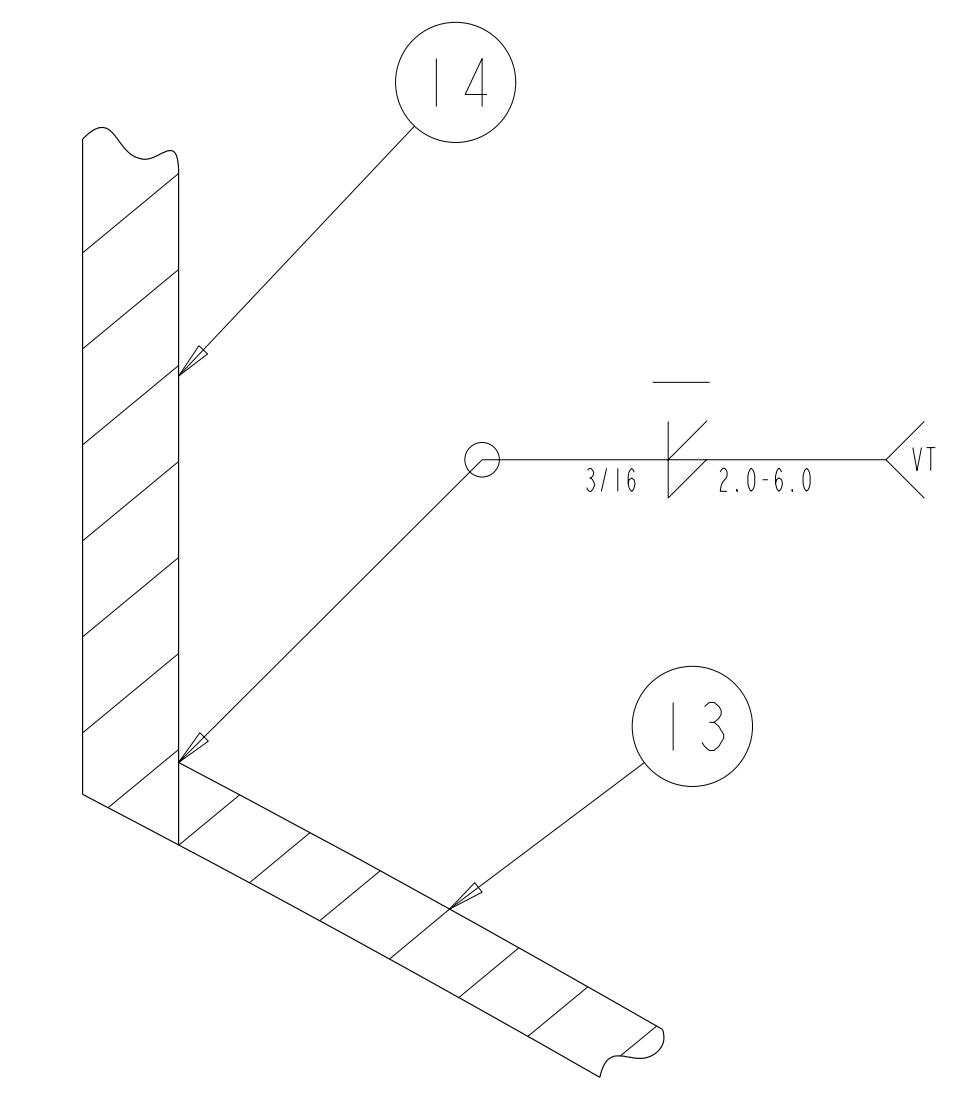

OPTIONAL WELD DETAIL

**RELEASED FOR FABRICATION / INSTALLATION**  
 PPPL Drafting:

UT-BATTELLE		Oak Ridge National Laboratory managed for the DEPARTMENT OF ENERGY under U.S. GOVERNMENT contract DE-AC05-00OR22725 UT-BATTELLE, LLC, Oak Ridge, Tennessee					
NATIONAL COMPACT STELLARATOR EXPERIMENT							
VACUUM VESSEL							
PERIOD INSPECTION AND LEAK CHECK							
ASSEMBLY							
VERSION NO.	PLANT	BLDG	FL	SHT OF	TYPE	CLASS	
5	X-10	5700	3	13	19	A	
RELEASE LEVEL	SE120-004						REV
Fabrication							2

H  
G  
F  
E  
D  
C  
B  
A

FOR PARTS LIST AND NOTES SEE SHEET 1.

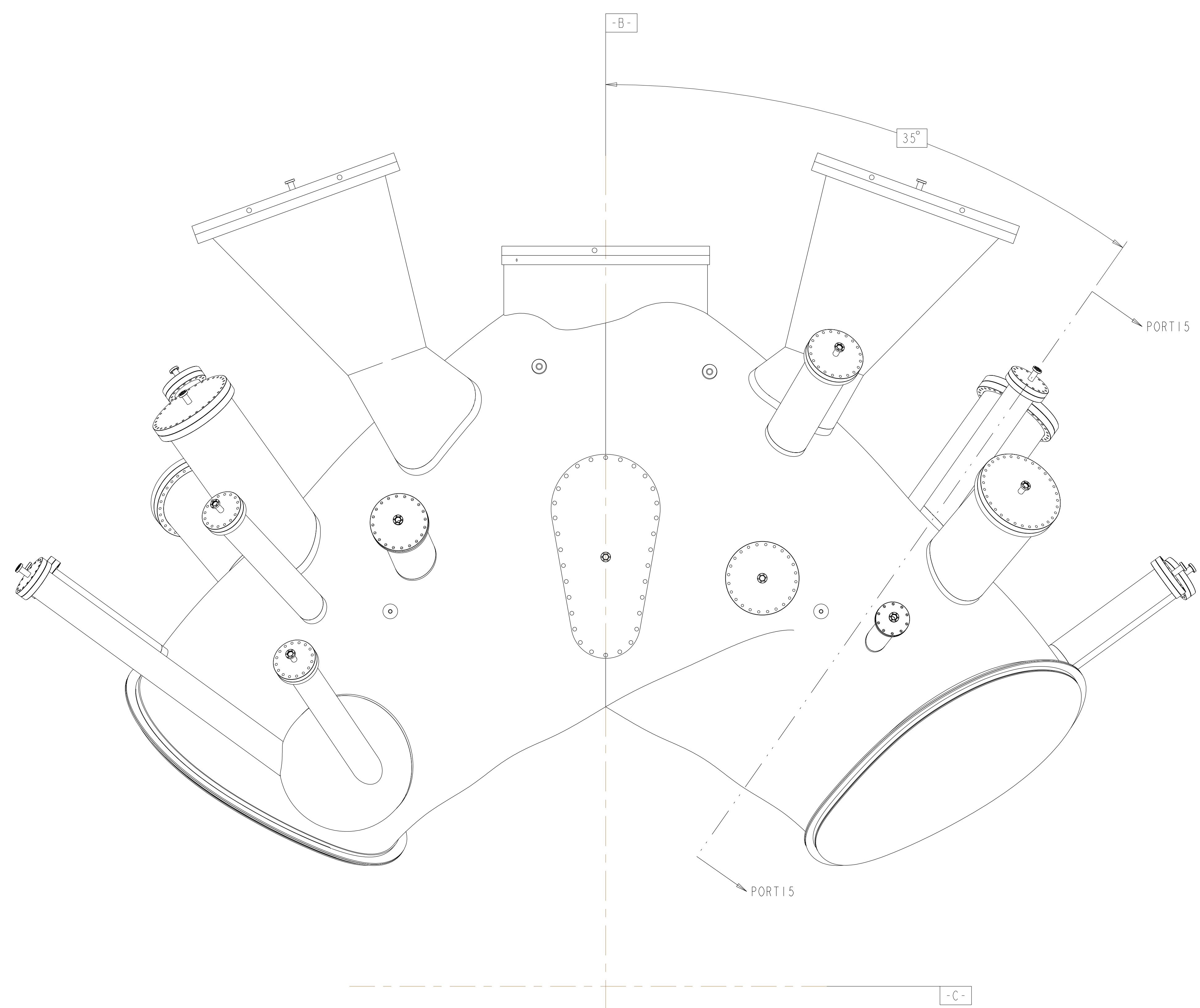

BOTTOM VIEW

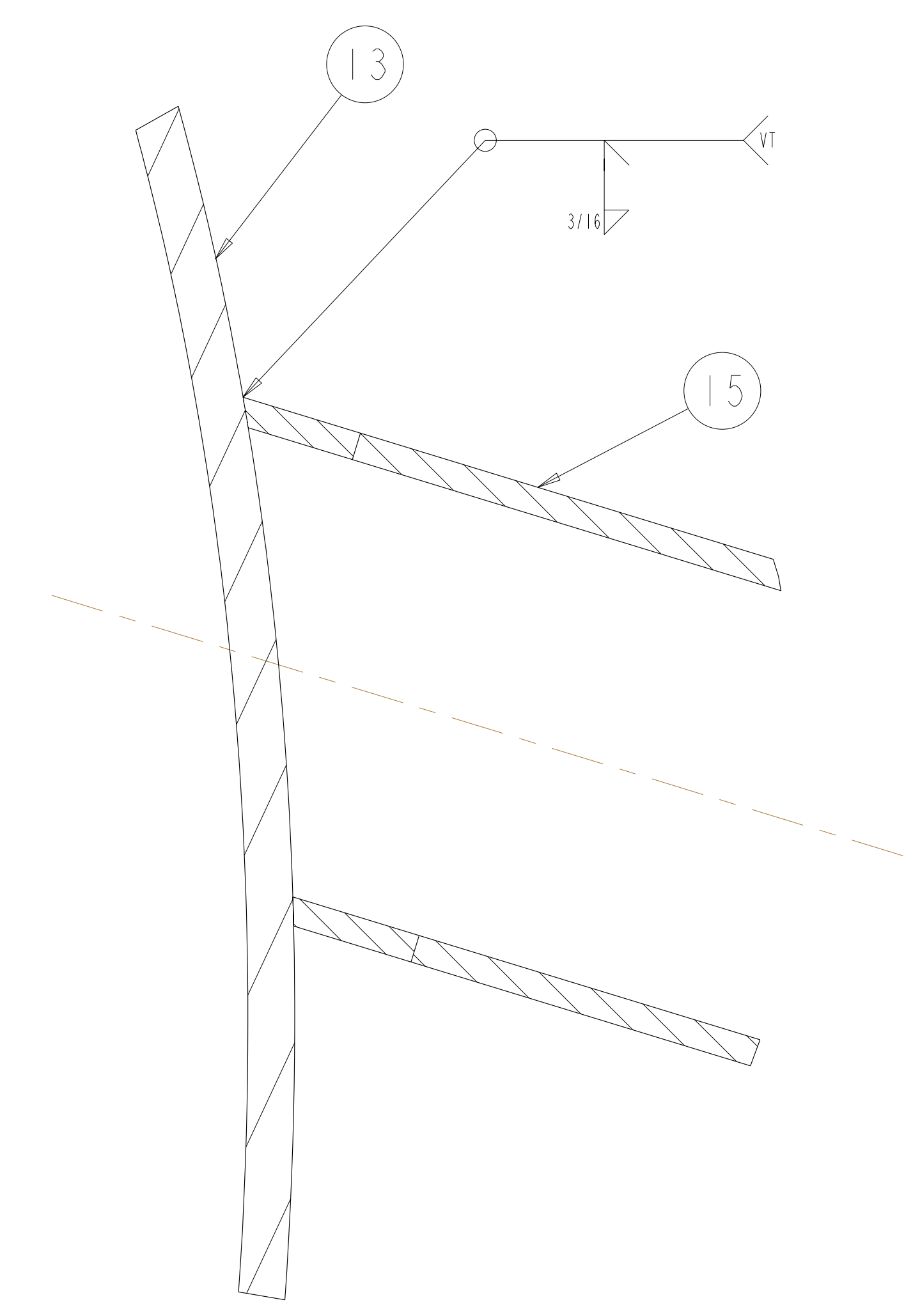

DETAIL X  
SCALE 1.00

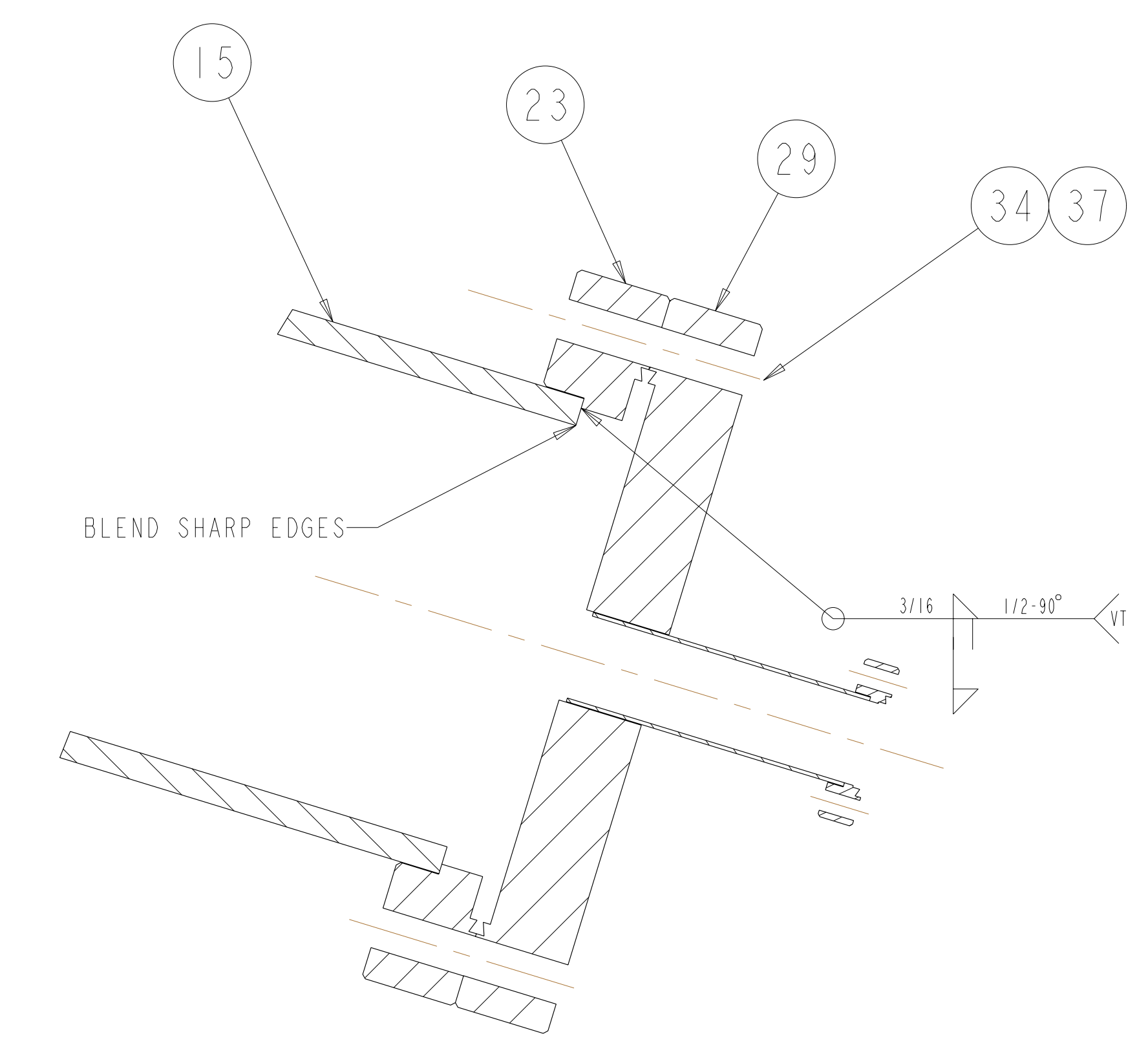

DETAIL Y  
SCALE 1.00

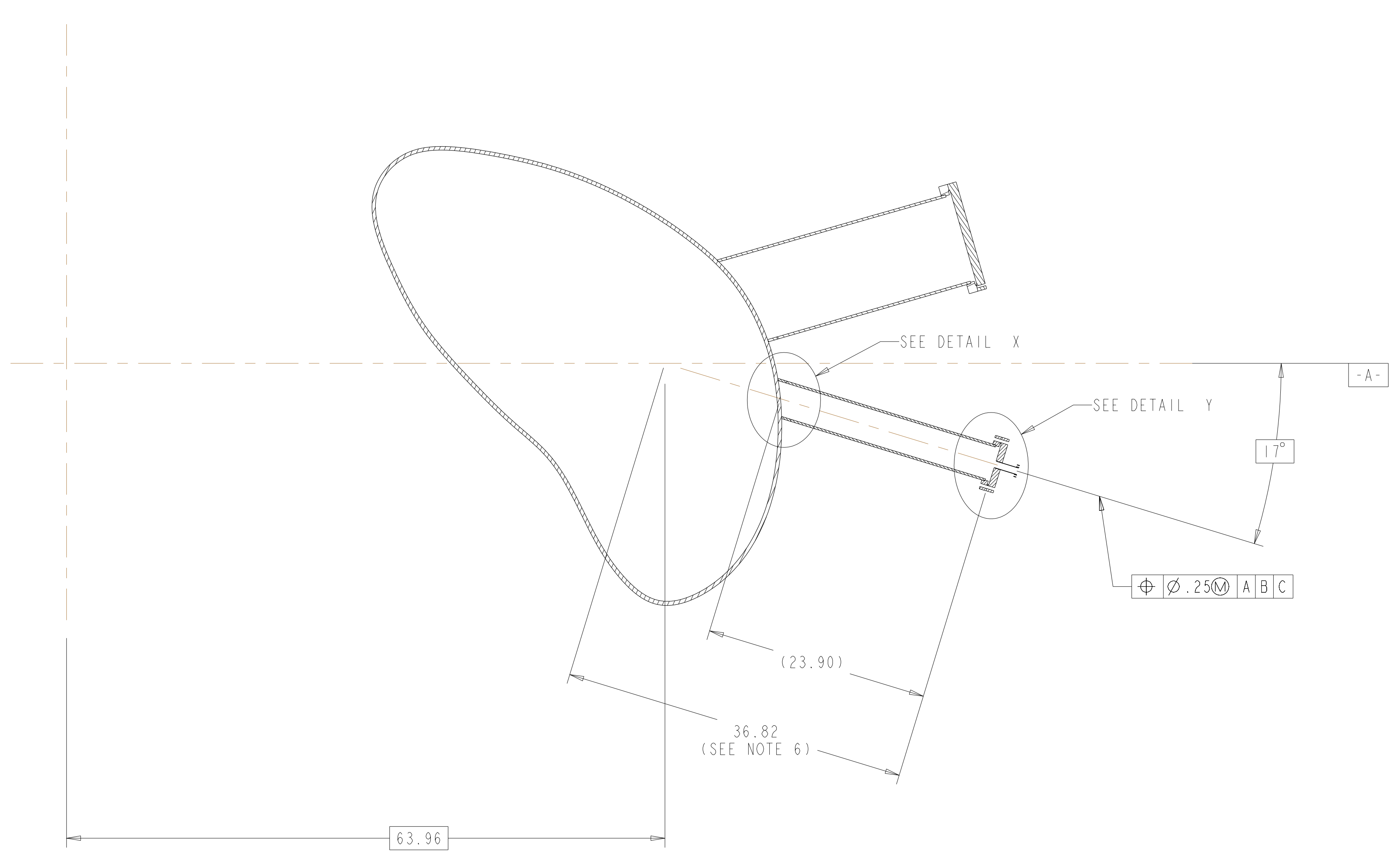

TYPICAL PORT 15A AND 15B  
SECTION PORT15-PORT15

**RELEASED FOR  
FABRICATION / INSTALLATION**  
 PPPL Drafting:

<b>UT-BATTELLE</b>		Oak Ridge National Laboratory managed for the DEPARTMENT OF ENERGY under U.S. GOVERNMENT contract DE-AC05-00OR22725 UT-BATTELLE, LLC, Oak Ridge, Tennessee					
PROJECT NAME		NATIONAL COMPACT STELLARATOR EXPERIMENT					
PERIOD INSPECTION AND LEAK CHECK ASSEMBLY		VACUUM VESSEL					
VERSION NO.	PLANT	BLDG	FL	SHT OF	TYPE	CLASS	
5	X-10	5700	3	14 19	A	U	
RELEASE LEVEL		SE120-004					REV
Fabrication							2

H  
G  
F  
E  
D  
C  
B  
A

FOR PARTS LIST AND NOTES SEE SHEET 1

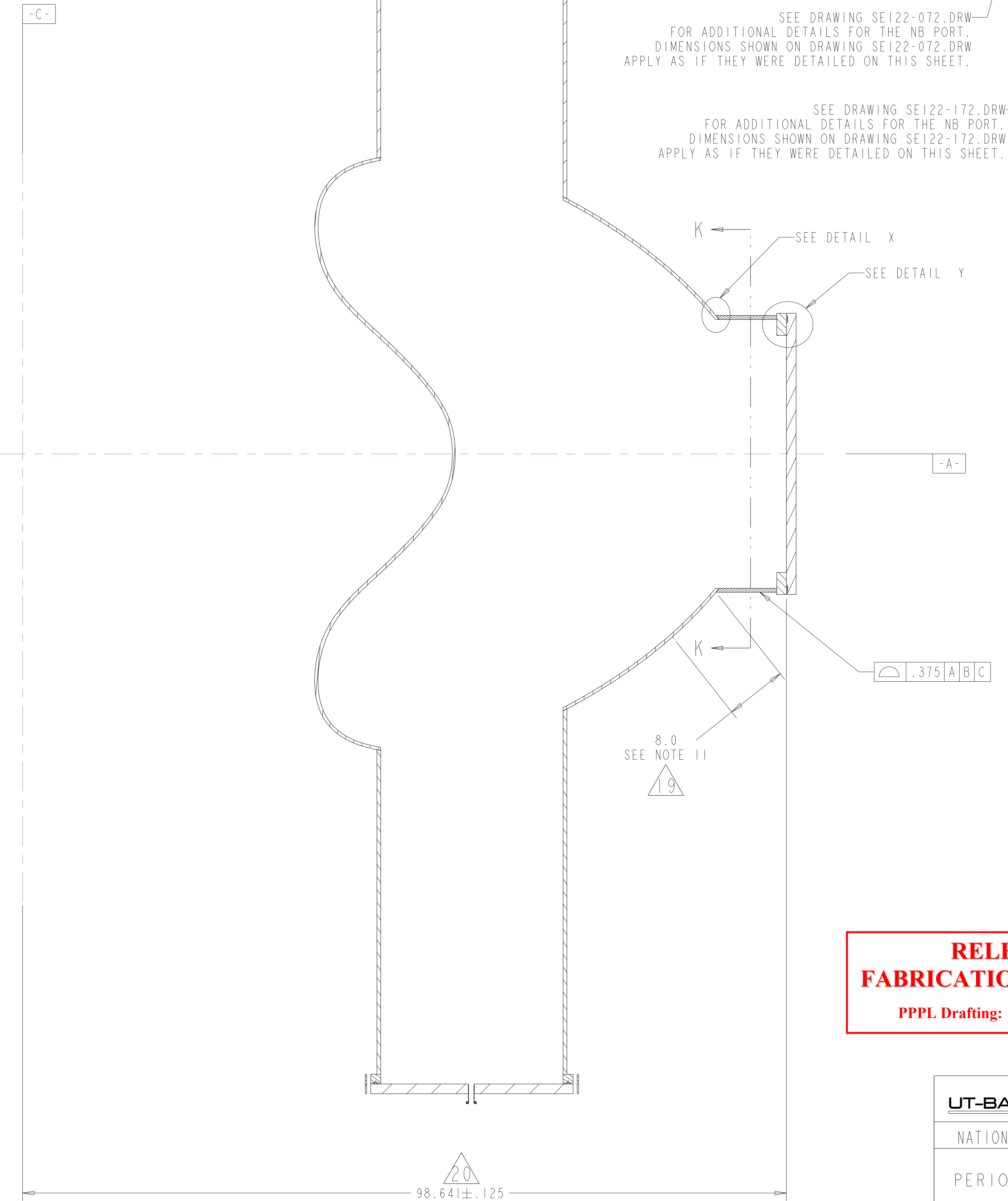
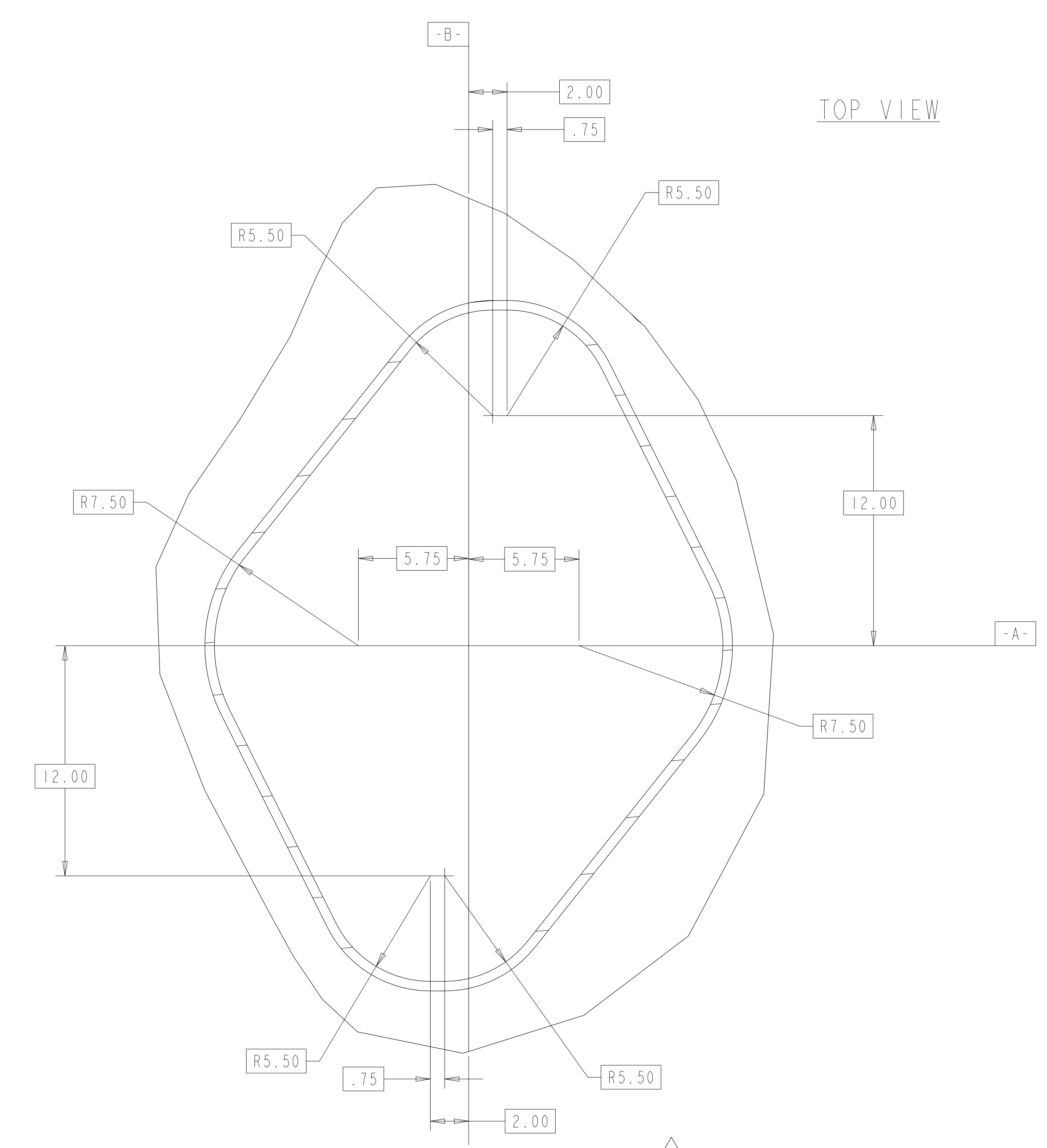
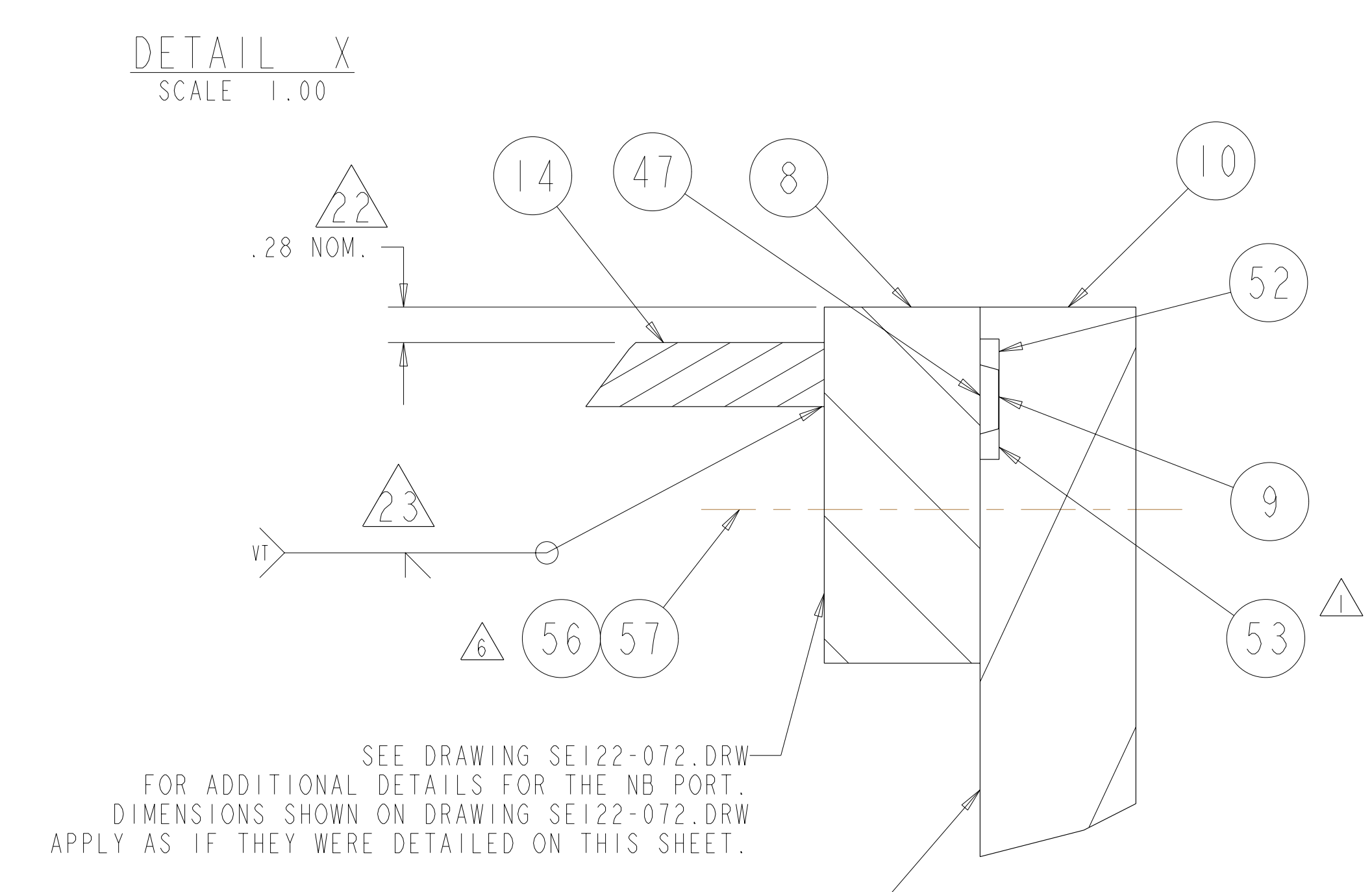
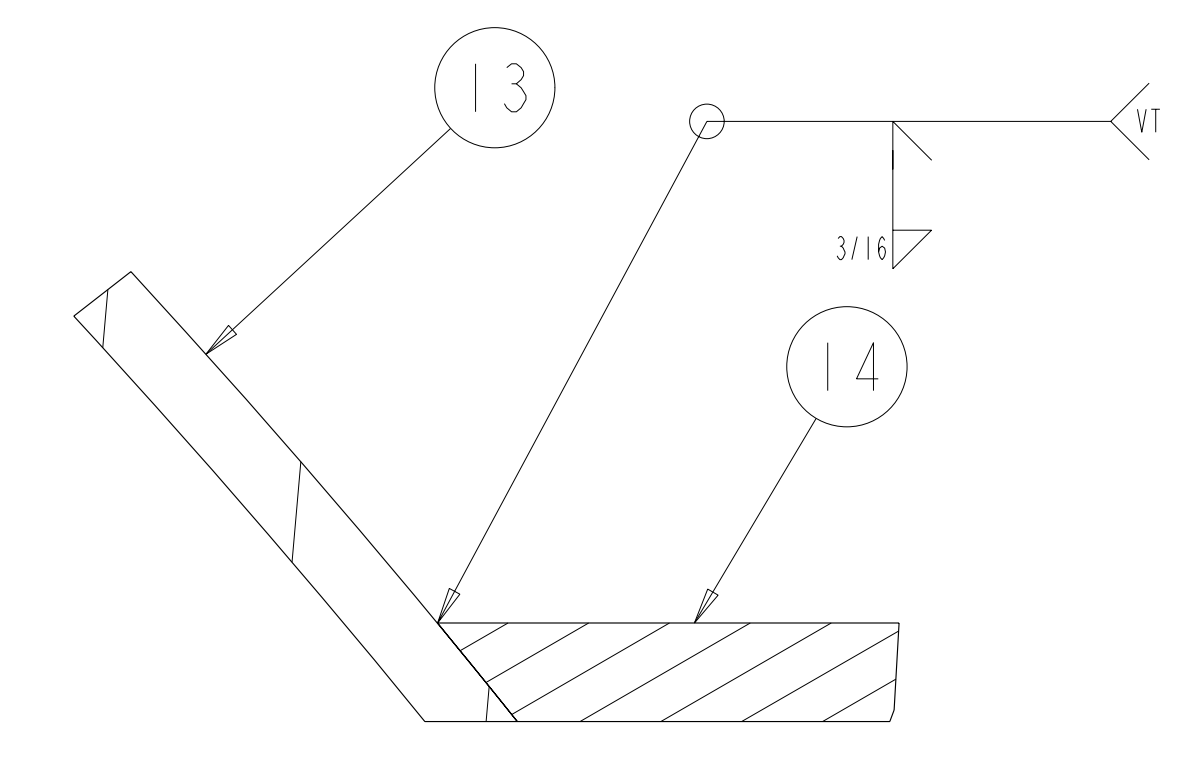
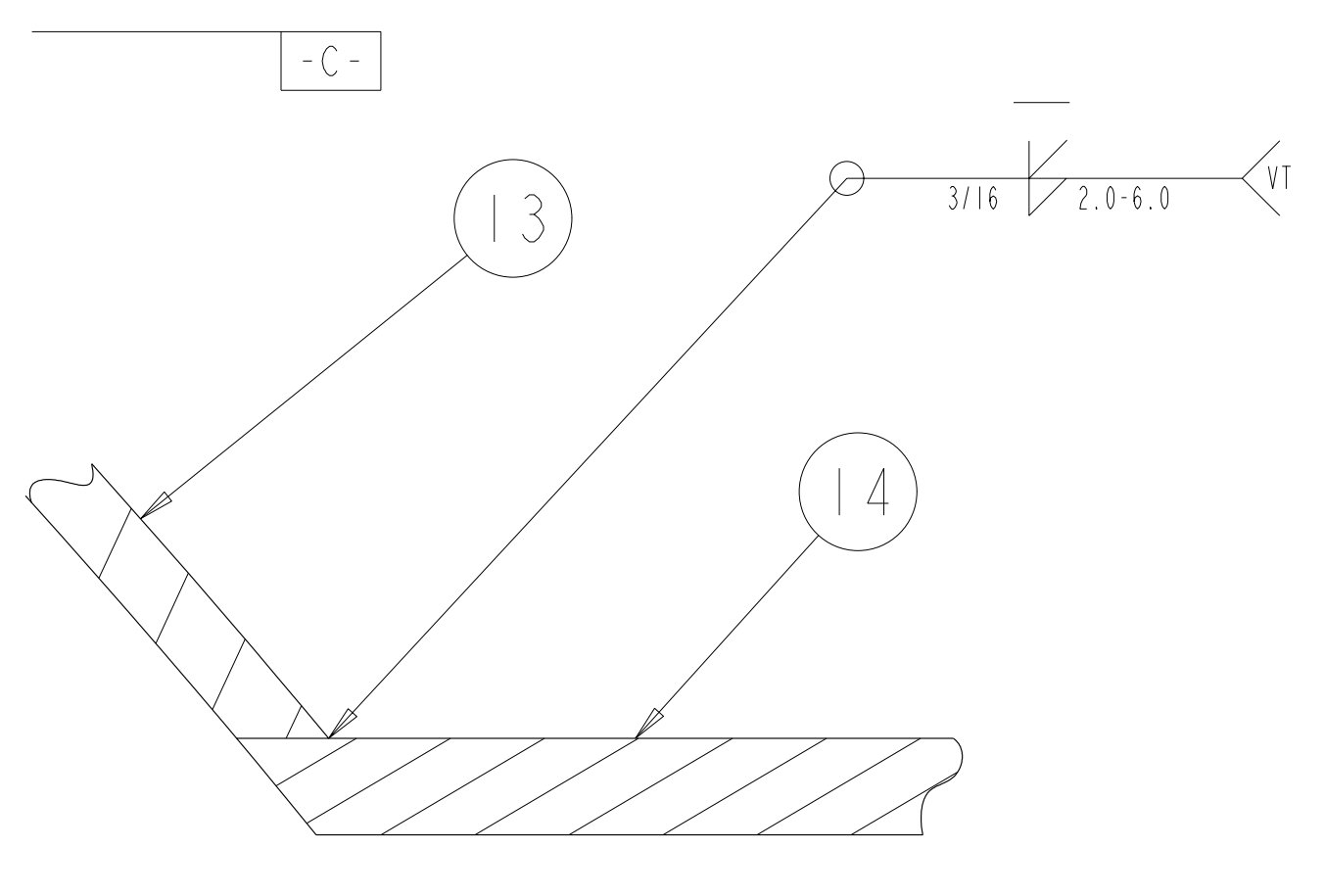
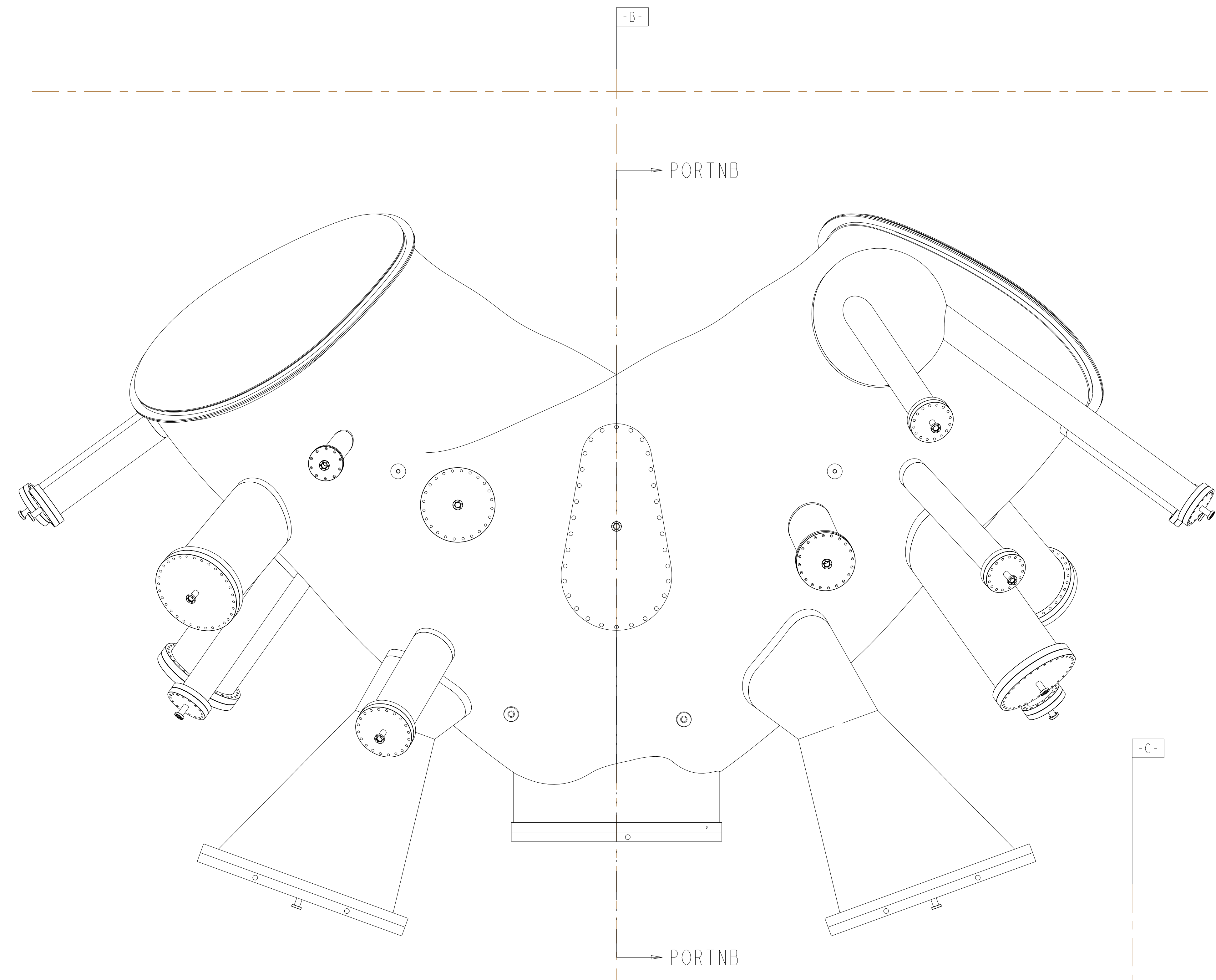

**RELEASED FOR FABRICATION / INSTALLATION**  
 PPPL Drafting:

UT-BATTELLE						Oak Ridge National Laboratory managed for the DEPARTMENT OF ENERGY under U.S. GOVERNMENT contract DE-AC05-00OR22725 UT-BATTELLE, LLC, Oak Ridge, Tennessee					
PROJECT NAME											
NATIONAL COMPACT STELLARATOR EXPERIMENT											
VACUUM VESSEL											
PERIOD INSPECTION AND LEAK CHECK ASSEMBLY											
VERSION NO.	PLANT	BLDG	FL	SHT OF	TYPE	CLASS					
5	X-10	5700	3	15	A	U					
RELEASE LEVEL											
Fabrication		SE120-004									
											REV 2

H  
G  
F  
E  
D  
C  
B  
A

FOR PARTS LIST AND NOTES SEE SHEET 1.

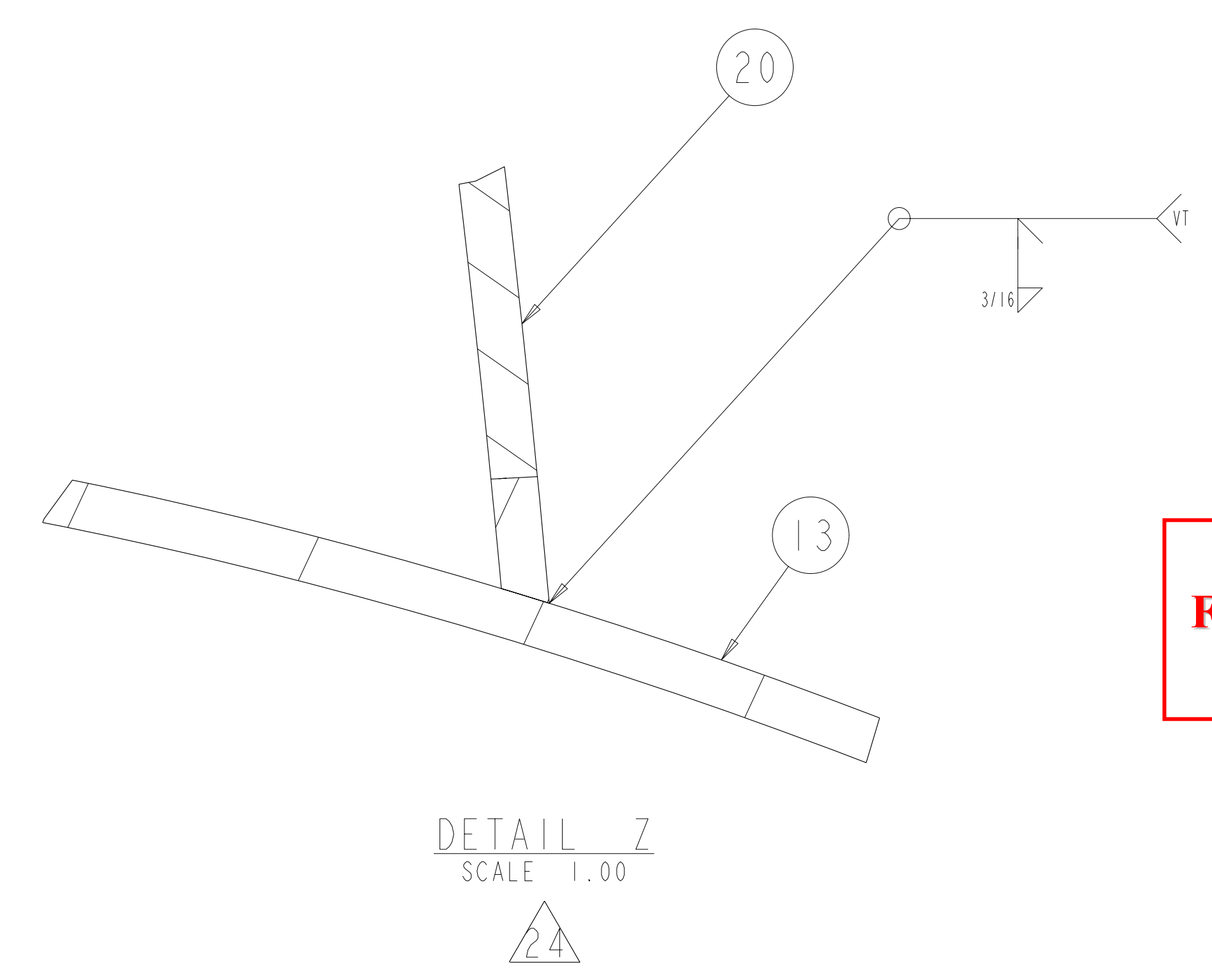
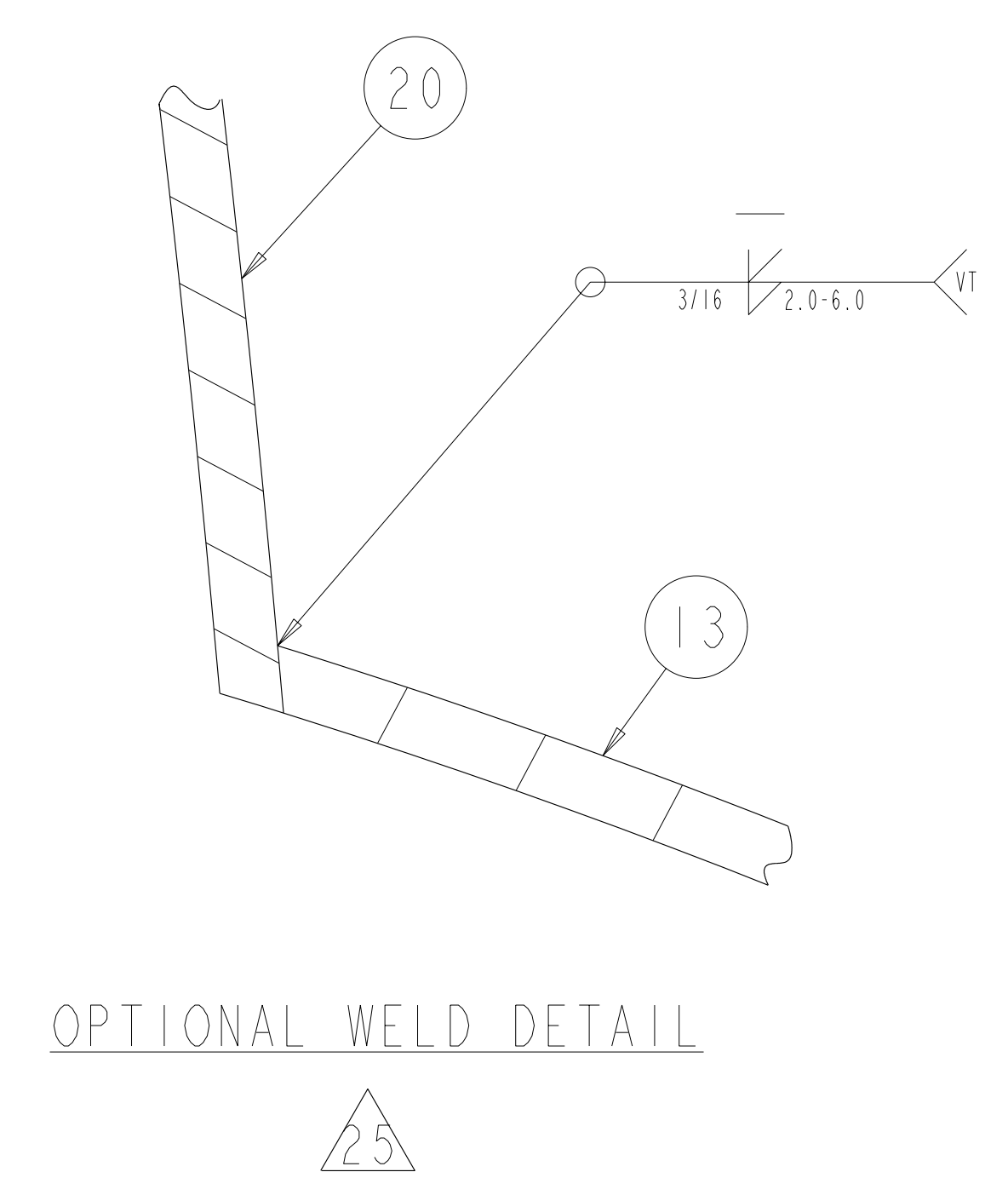
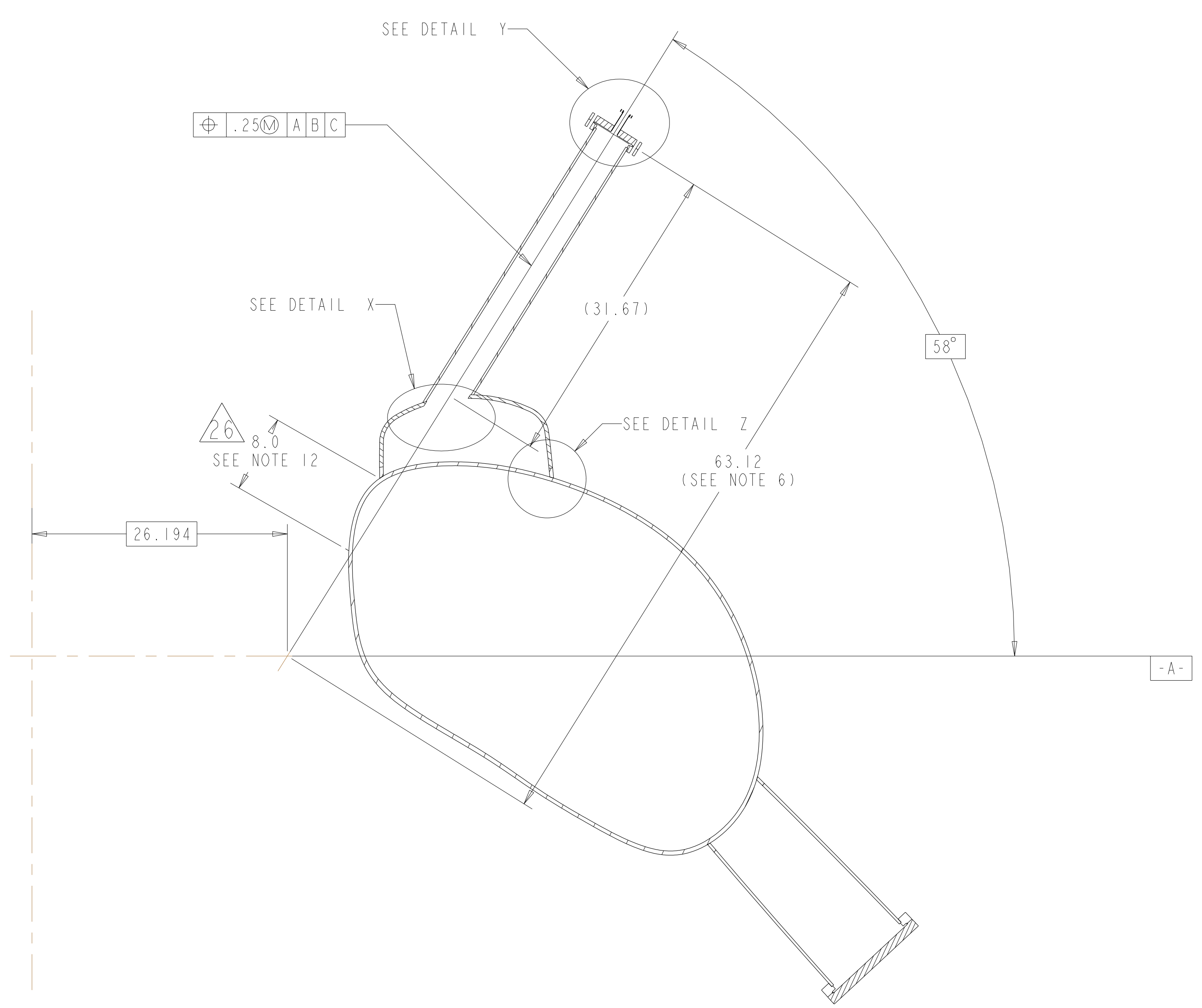
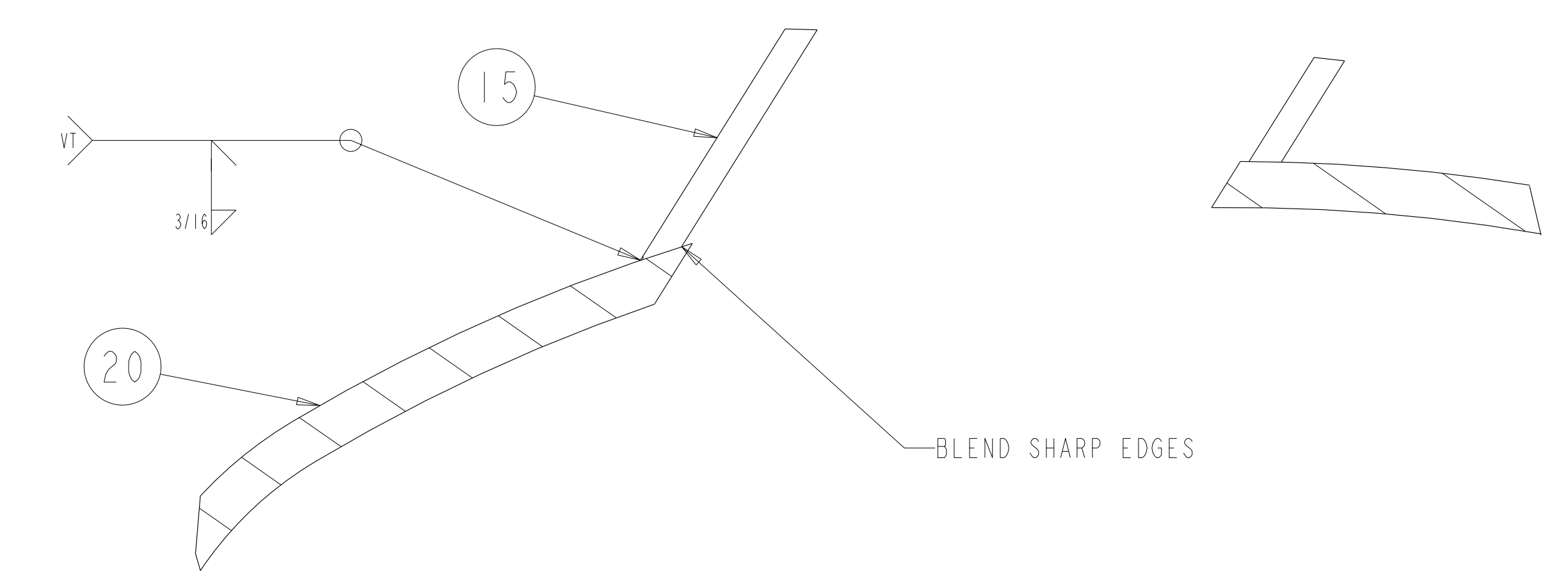
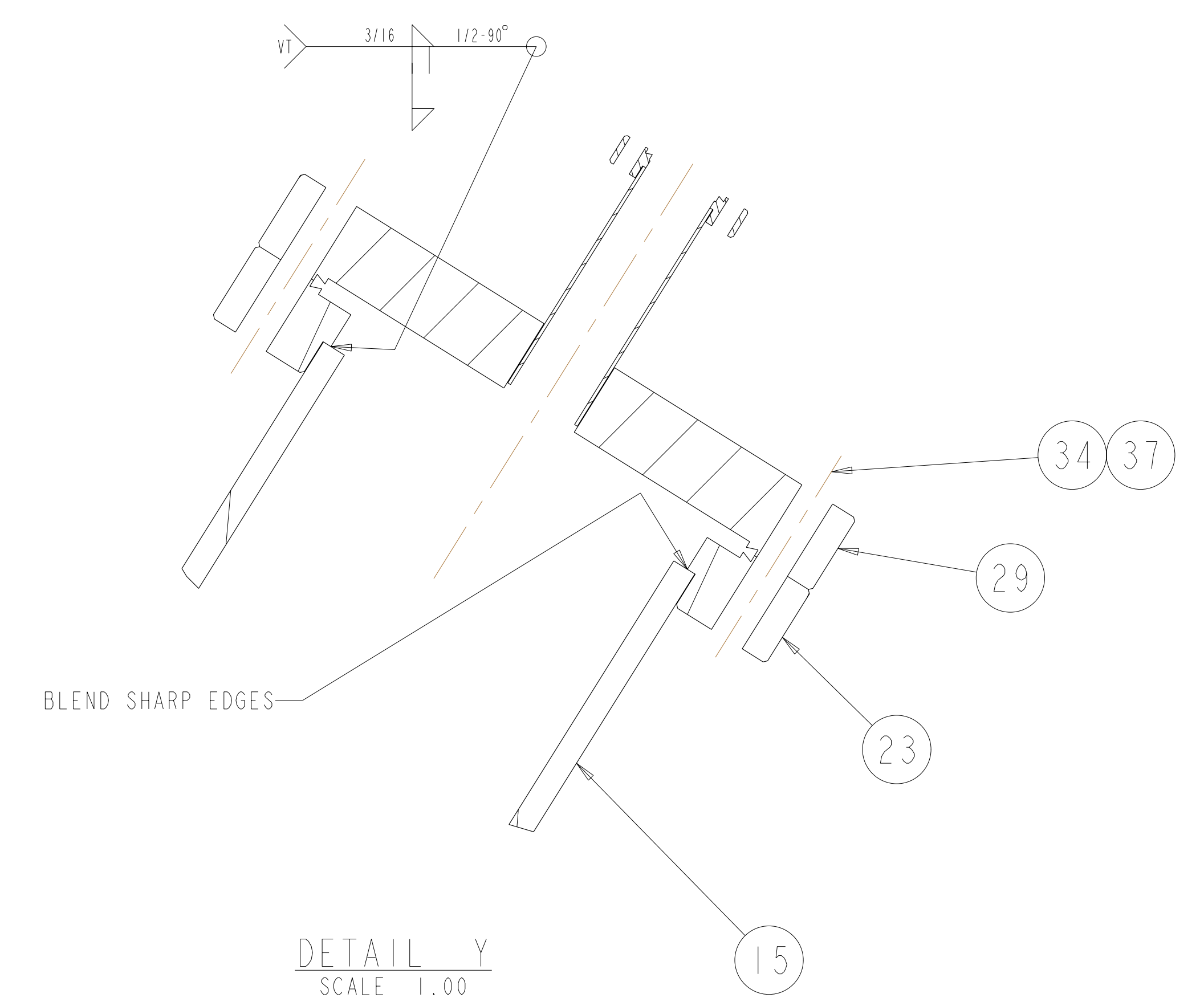
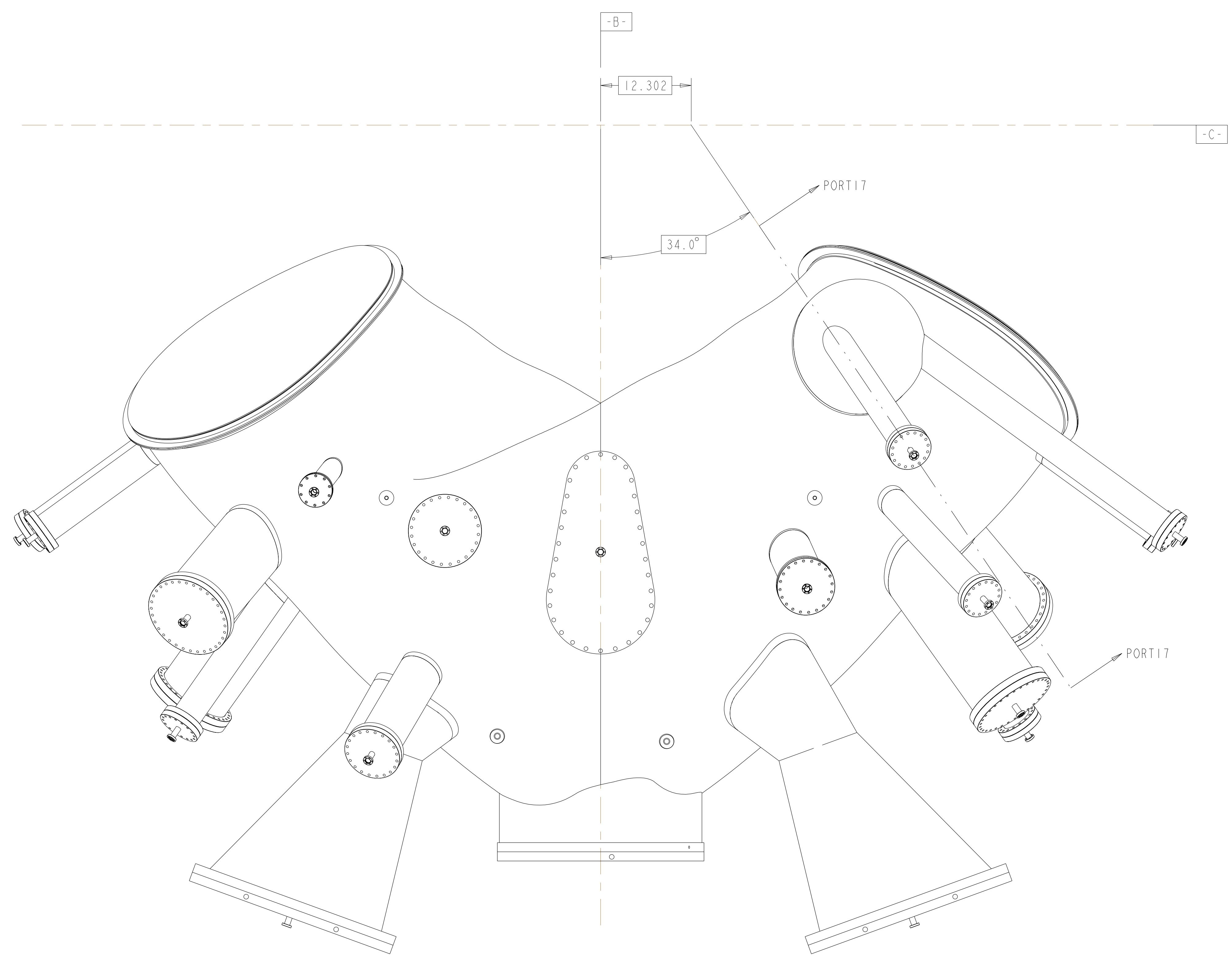

**RELEASED FOR  
FABRICATION / INSTALLATION**  
 PPPL Drafting:

Oak Ridge National Laboratory managed for the DEPARTMENT OF ENERGY under U.S. GOVERNMENT contract DE-AC05-00OR22725 UT-BATTELLE, LLC, Oak Ridge, Tennessee PROJECT NAME						
NATIONAL COMPACT STELLARATOR EXPERIMENT VACUUM VESSEL PERIOD INSPECTION AND LEAK CHECK ASSEMBLY						
VERSION NO.	PLANT	BLDG	FL	SHT OF	TYPE	CLASS
5	X-10	5700	3	16	19	A
RELEASE LEVEL		SE120-004			REV	
Fabrication					2	

H  
G  
F  
E  
D  
C  
B  
A



FOR PARTS LIST AND NOTES SEE SHEET 1.

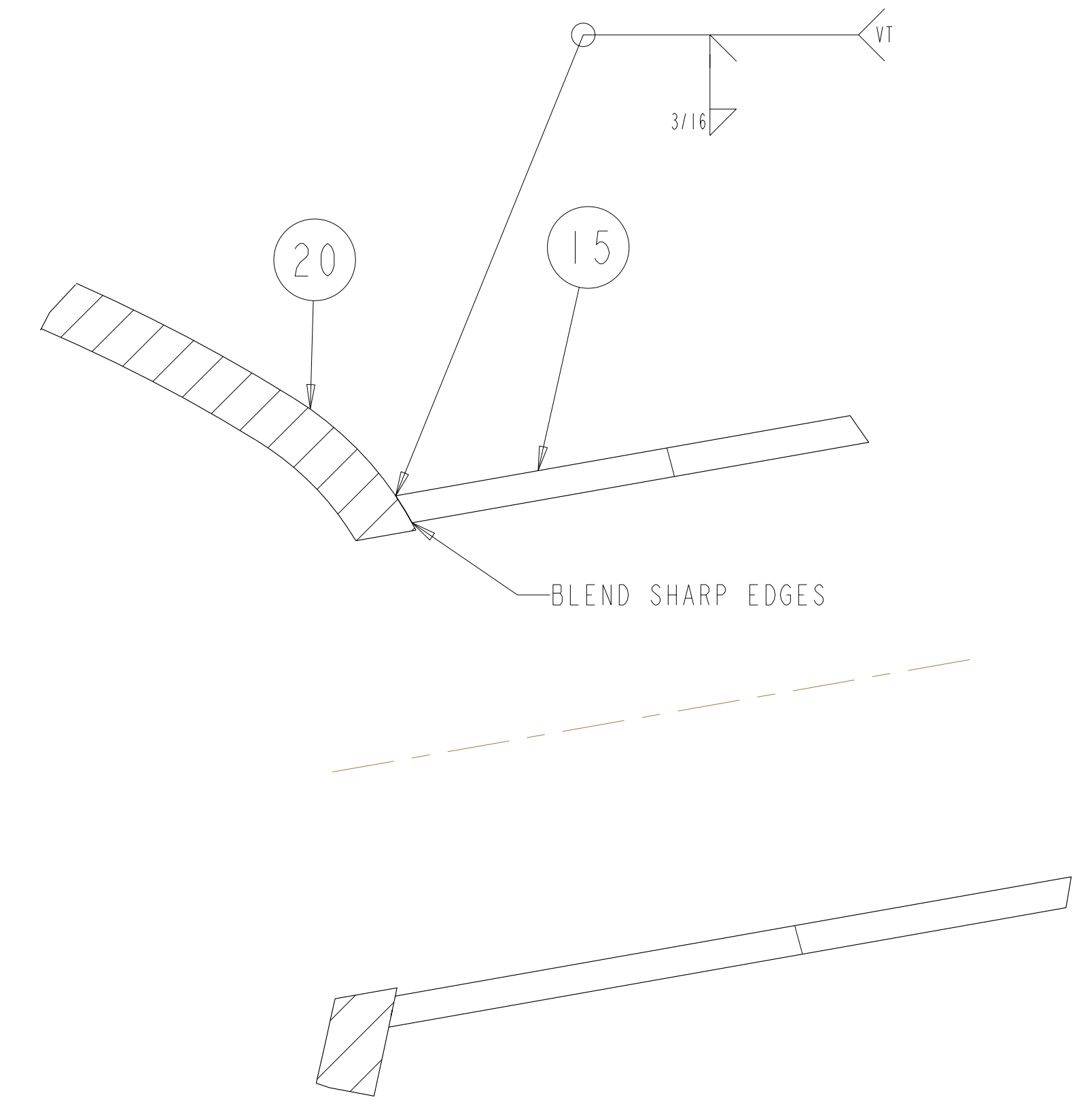
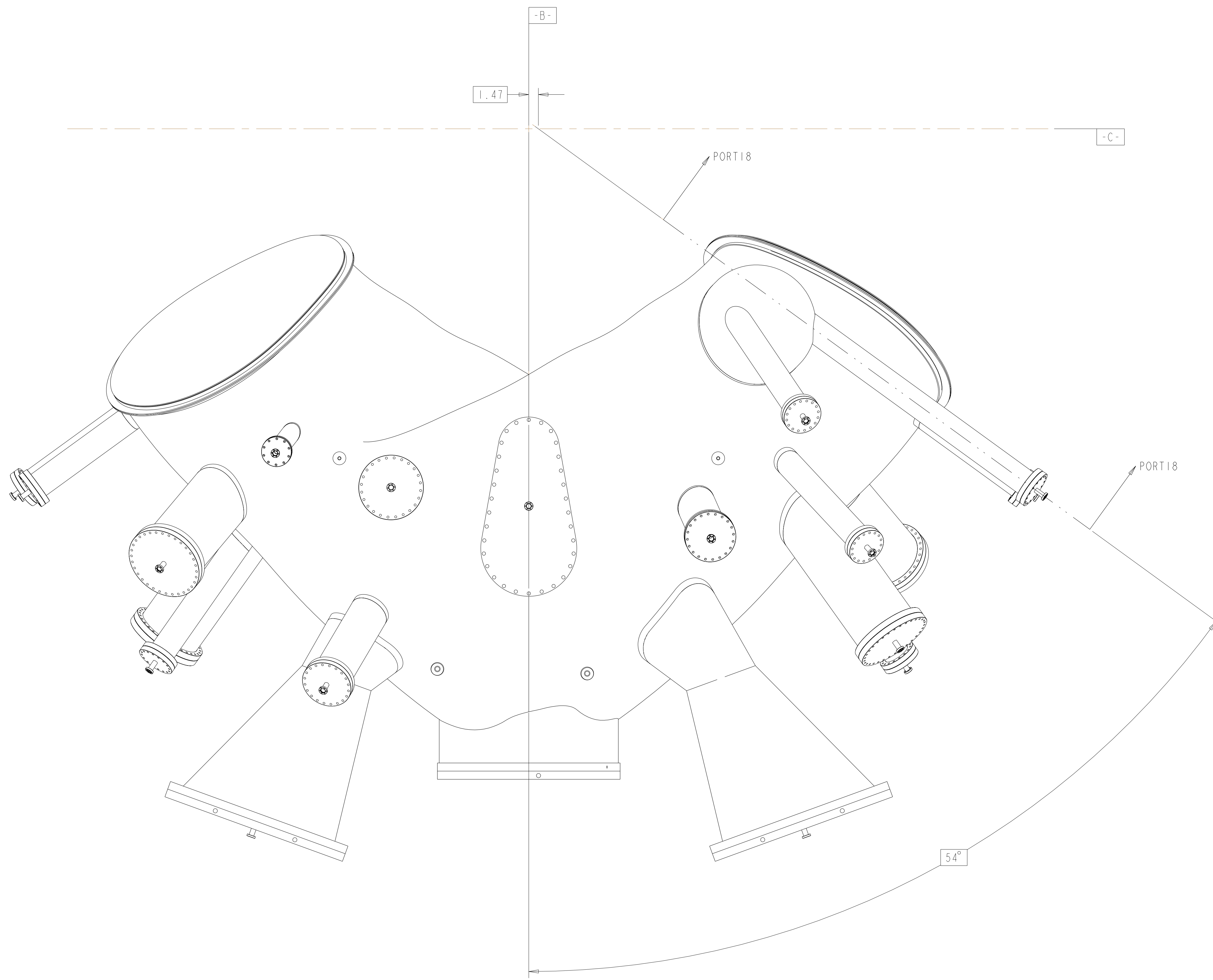

DETAIL X  
 SCALE 1.00

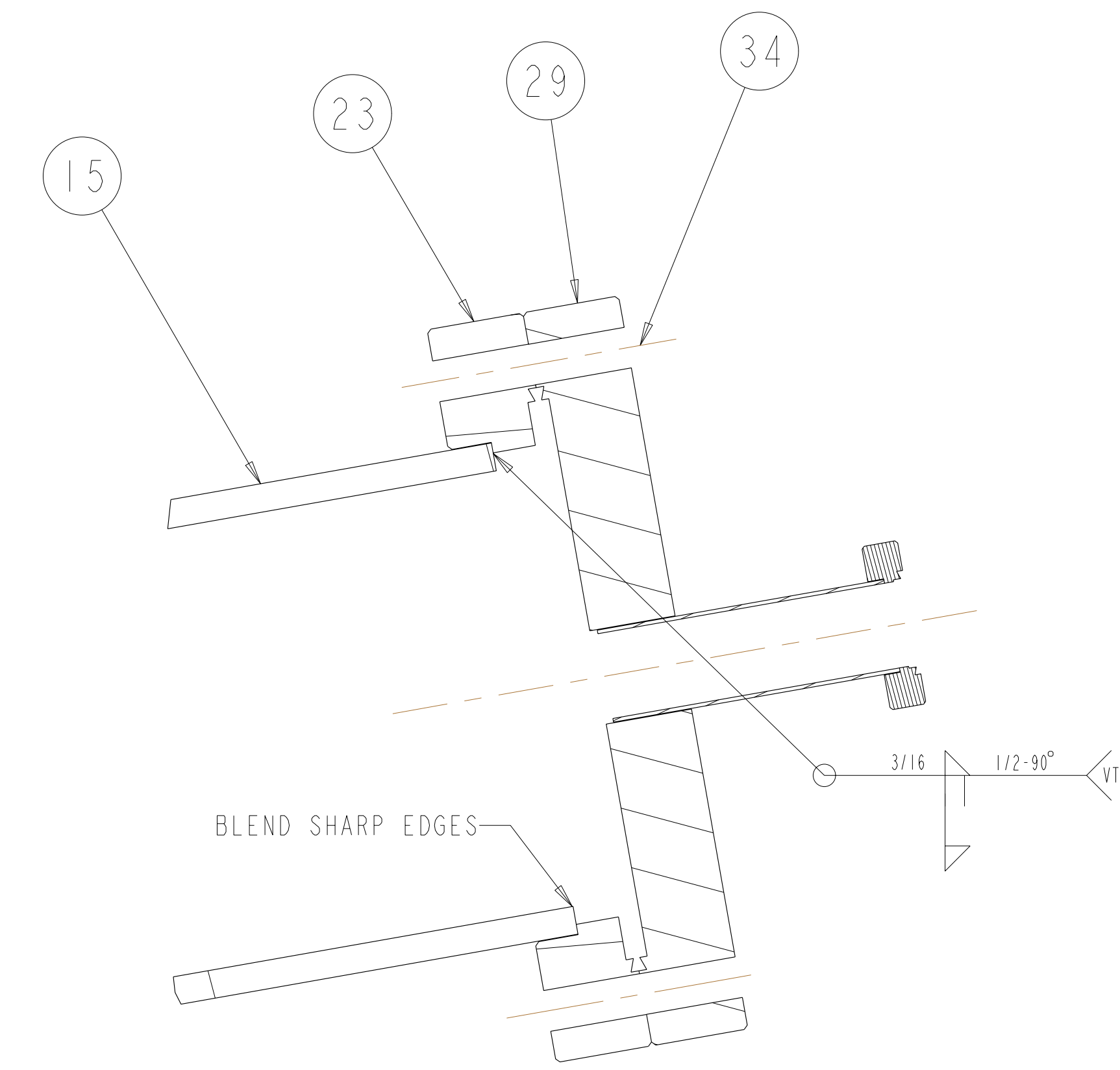

DETAIL Y  
 SCALE 1.000

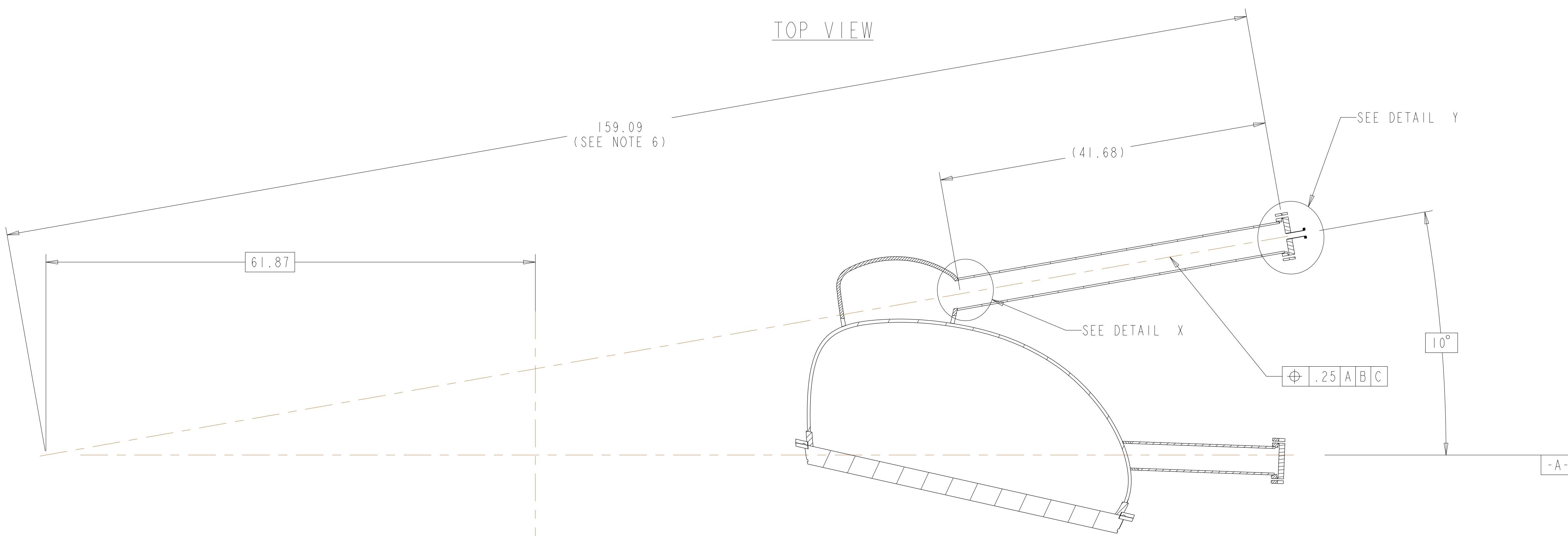

TYPICAL PORT 18A AND 18B  
 SECTION PORT18-PORT18

**RELEASED FOR  
 FABRICATION / INSTALLATION**  
 PPPL Drafting:

<b>UT-BATTELLE</b>		Oak Ridge National Laboratory managed for the DEPARTMENT OF ENERGY under U.S. GOVERNMENT contract DE-AC05-00OR22725 UT-BATTELLE, LLC, Oak Ridge, Tennessee						
PROJECT NAME								
NATIONAL COMPACT STELLARATOR EXPERIMENT								
VACUUM VESSEL								
PERIOD INSPECTION AND LEAK CHECK								
ASSEMBLY								
VERSION NO.	PLANT	BLDG	FL	SHT OF	TYPE	CLASS		
5	X-10	5700	3	17 19	A	U		
RELEASE LEVEL		SE120-004					REV	
Fabrication							2	

H  
G  
F  
E  
D  
C  
B  
A

FOR PARTS LIST AND NOTES SEE SHEET 1.

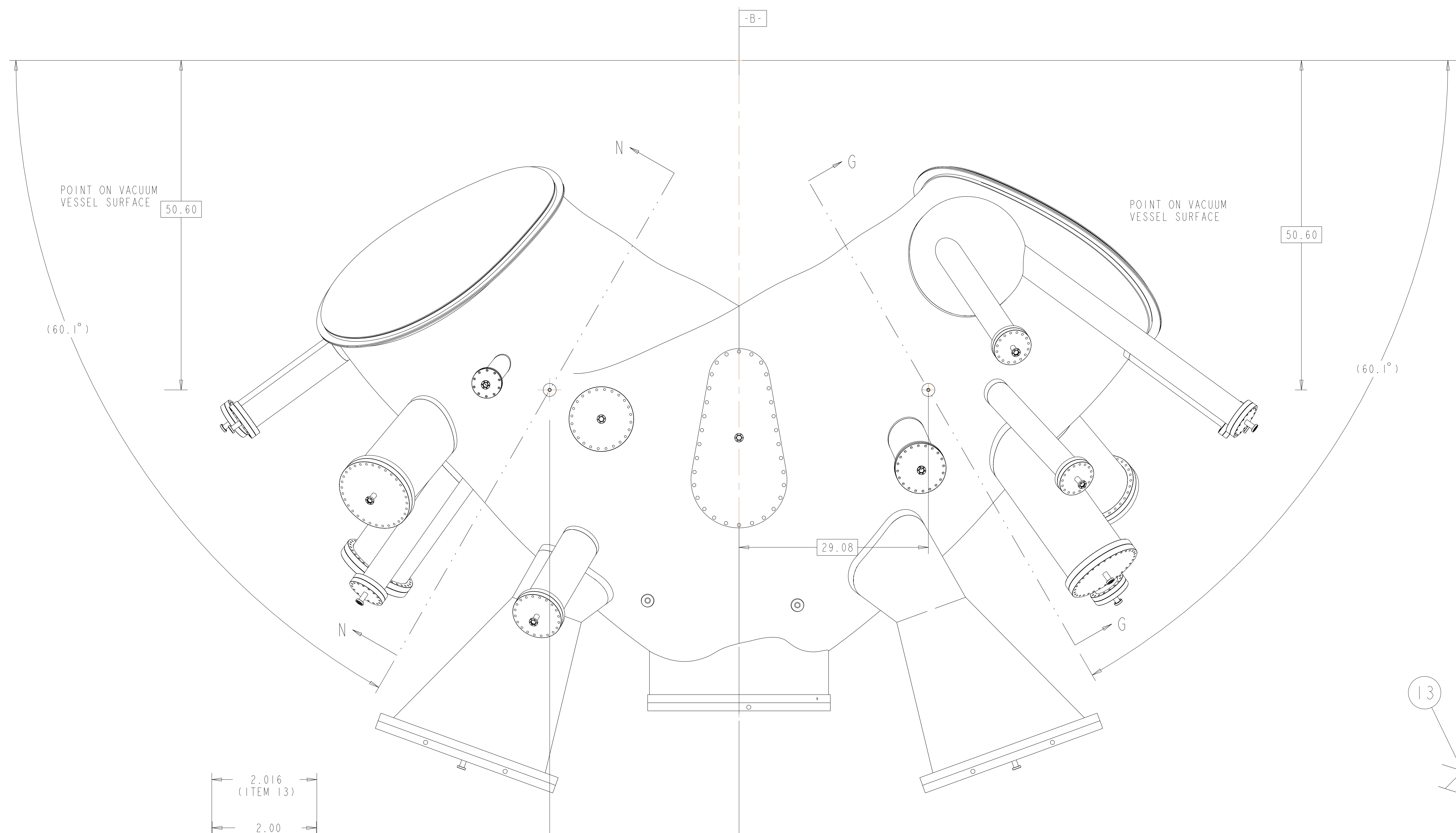

TOP VIEW

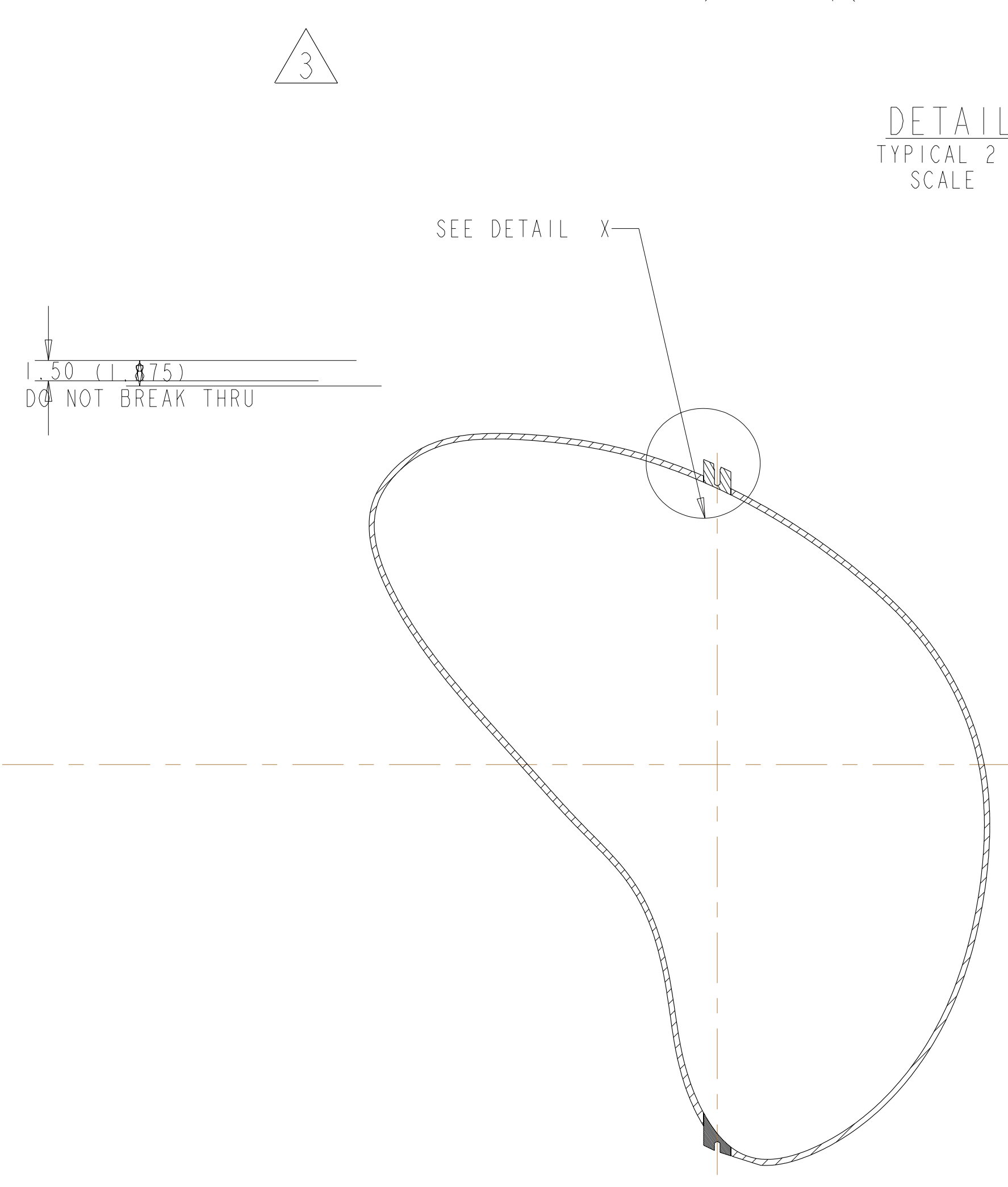
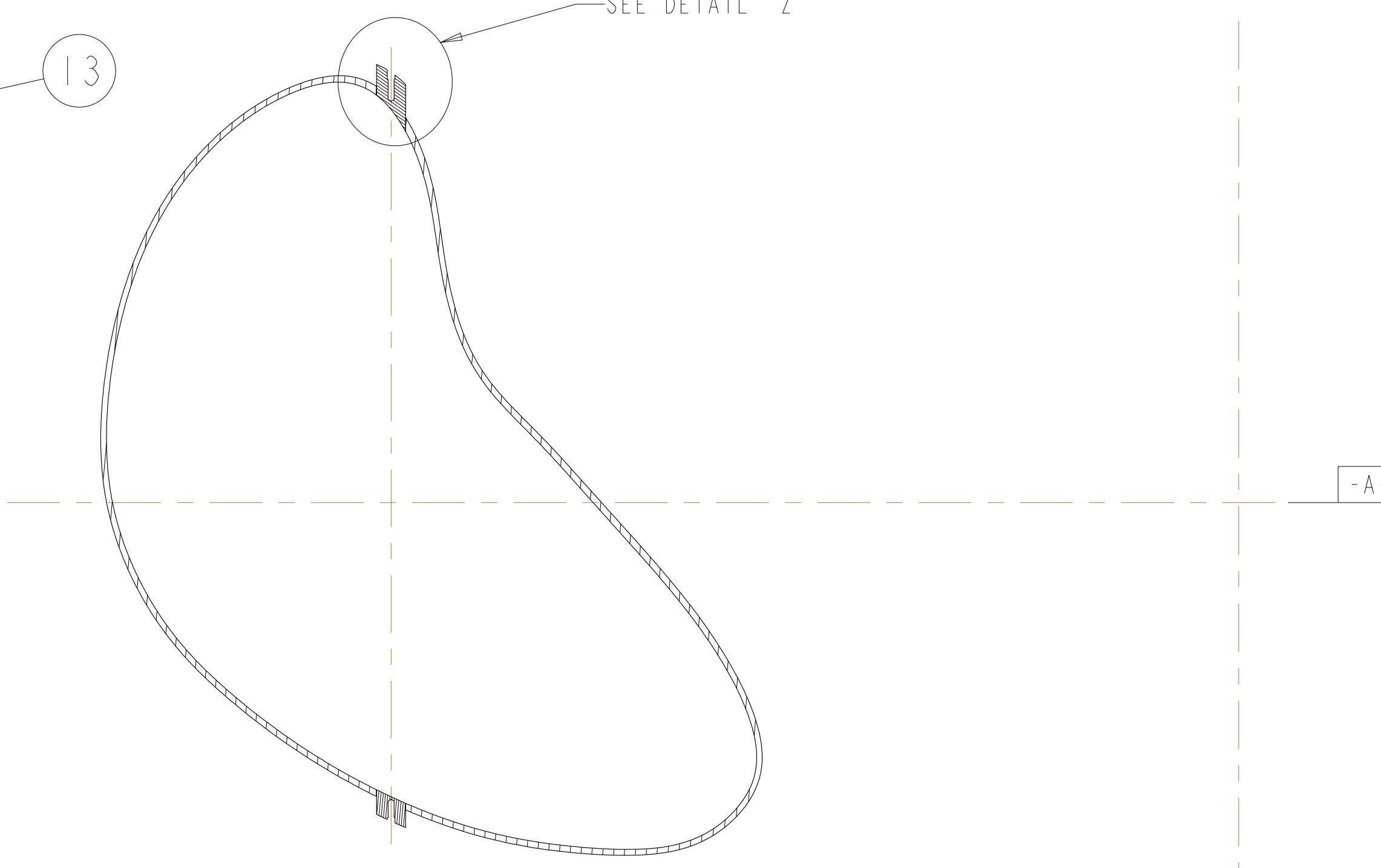
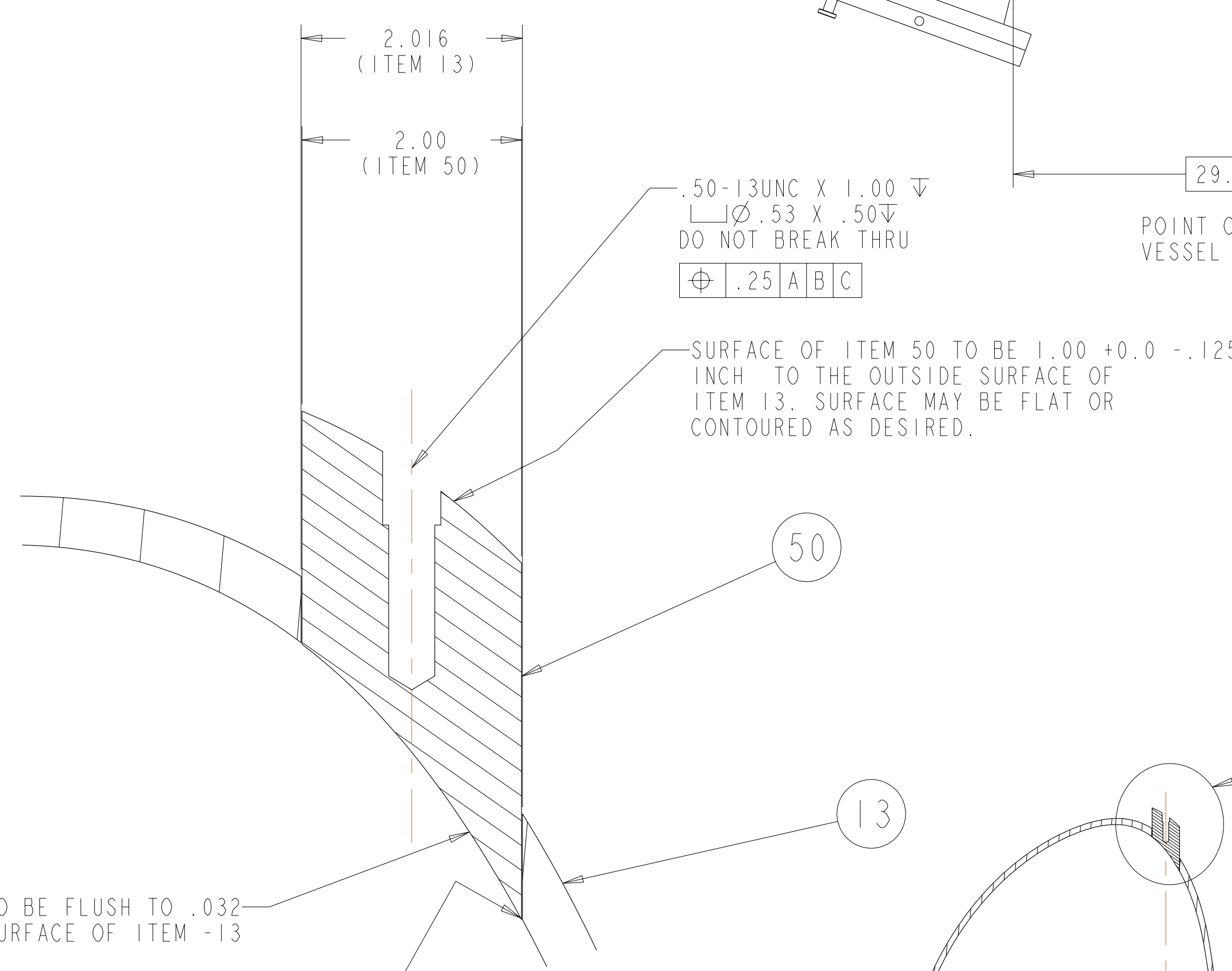
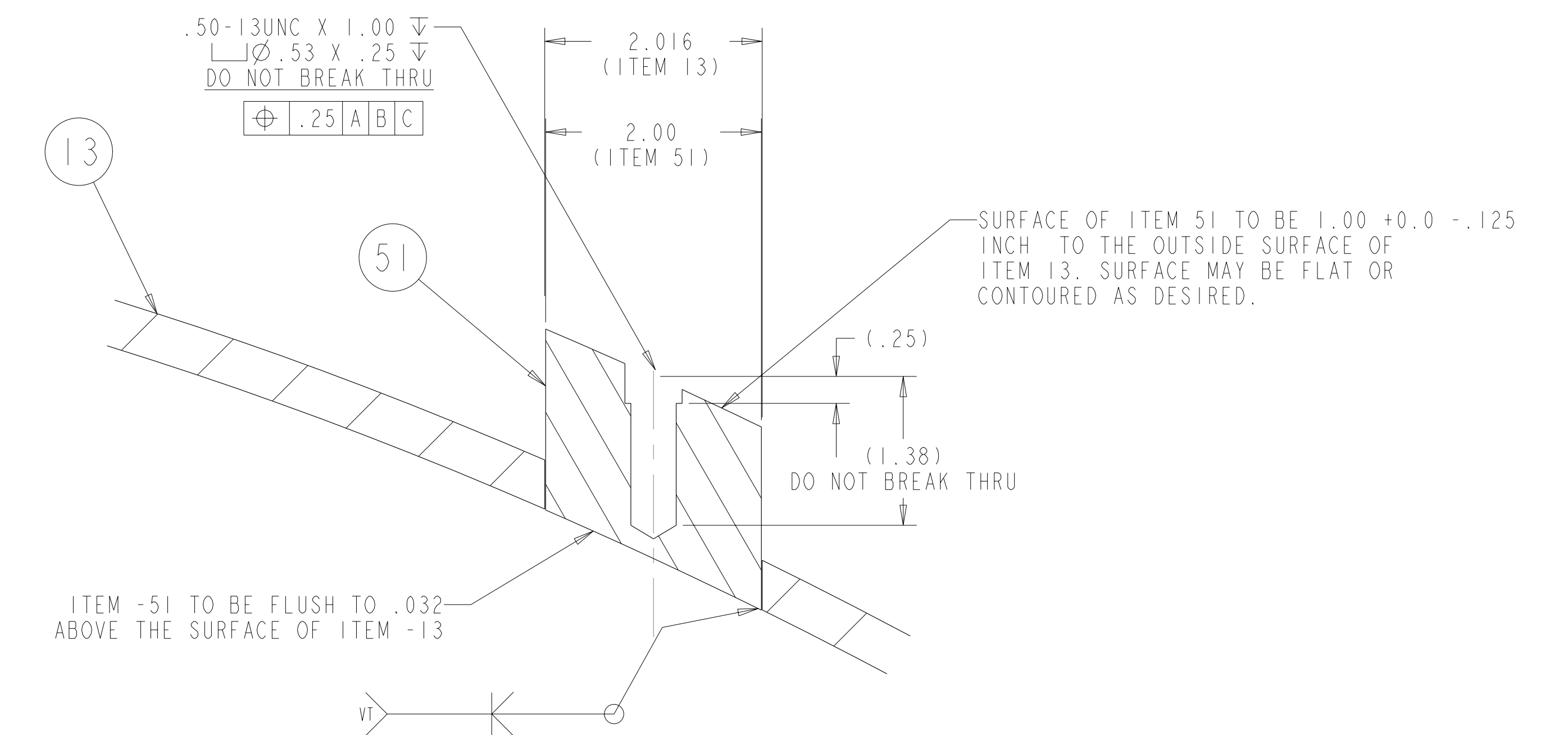

**RELEASED FOR  
FABRICATION / INSTALLATION**

PPPL Drafting:

UT-BATTELLE		Oak Ridge National Laboratory managed for the DEPARTMENT OF ENERGY under U.S. GOVERNMENT contract DE-AC05-00OR22725 UT-BATTELLE, LLC, Oak Ridge, Tennessee					
NATIONAL COMPACT STELLARATOR EXPERIMENT							
VACUUM VESSEL PERIOD INSPECTION AND LEAK CHECK ASSEMBLY							
VERSION NO.	PLANT	BLDG	FL	SHT OF	TYPE	CLASS	
3+	X-10	5700	3	8	19	A	U
RELEASE LEVEL	SE120-004						REV
Fabrication							2

H  
G  
F  
E  
D  
C  
B  
A

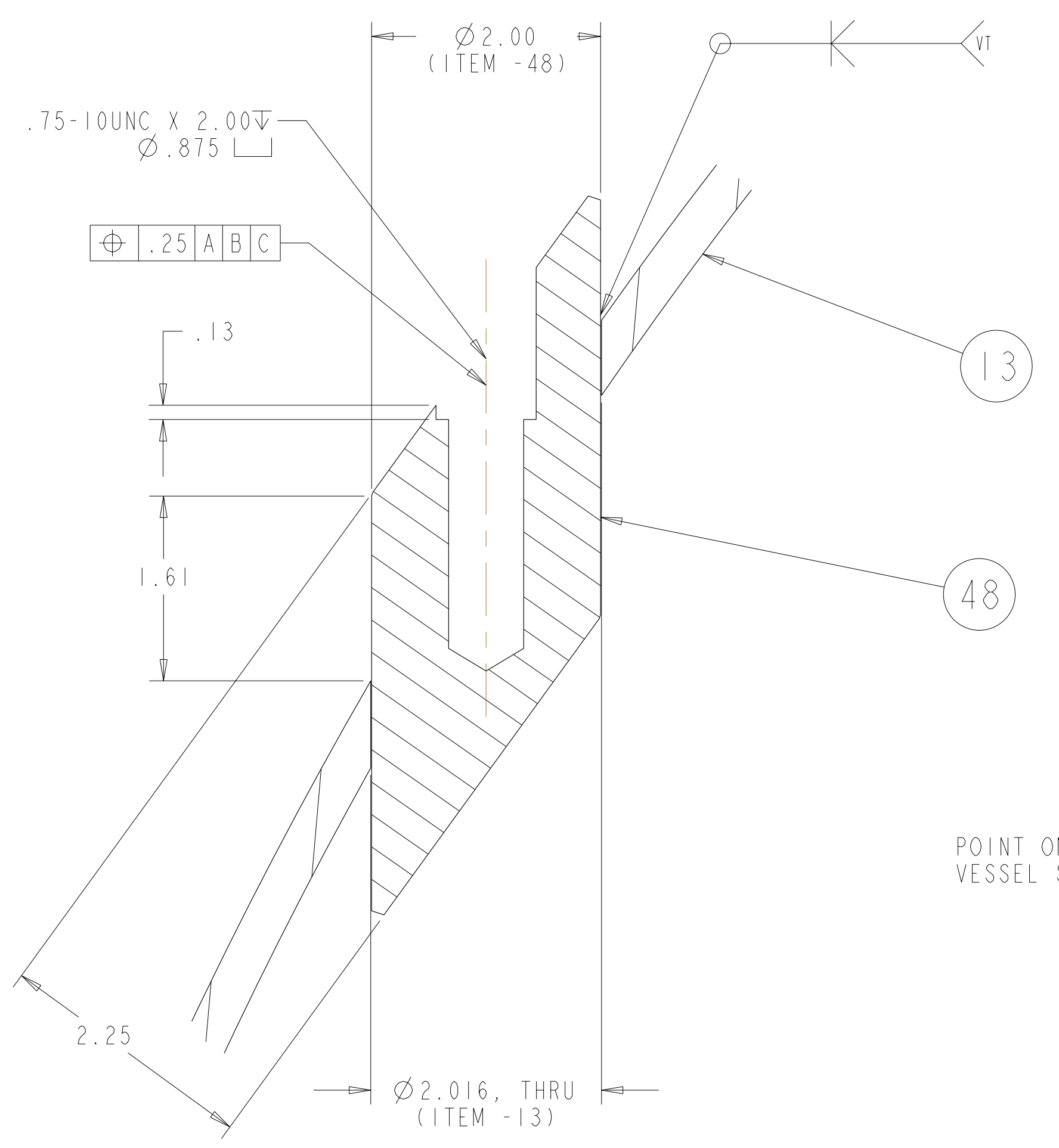

DETAIL W  
SCALE 1.00

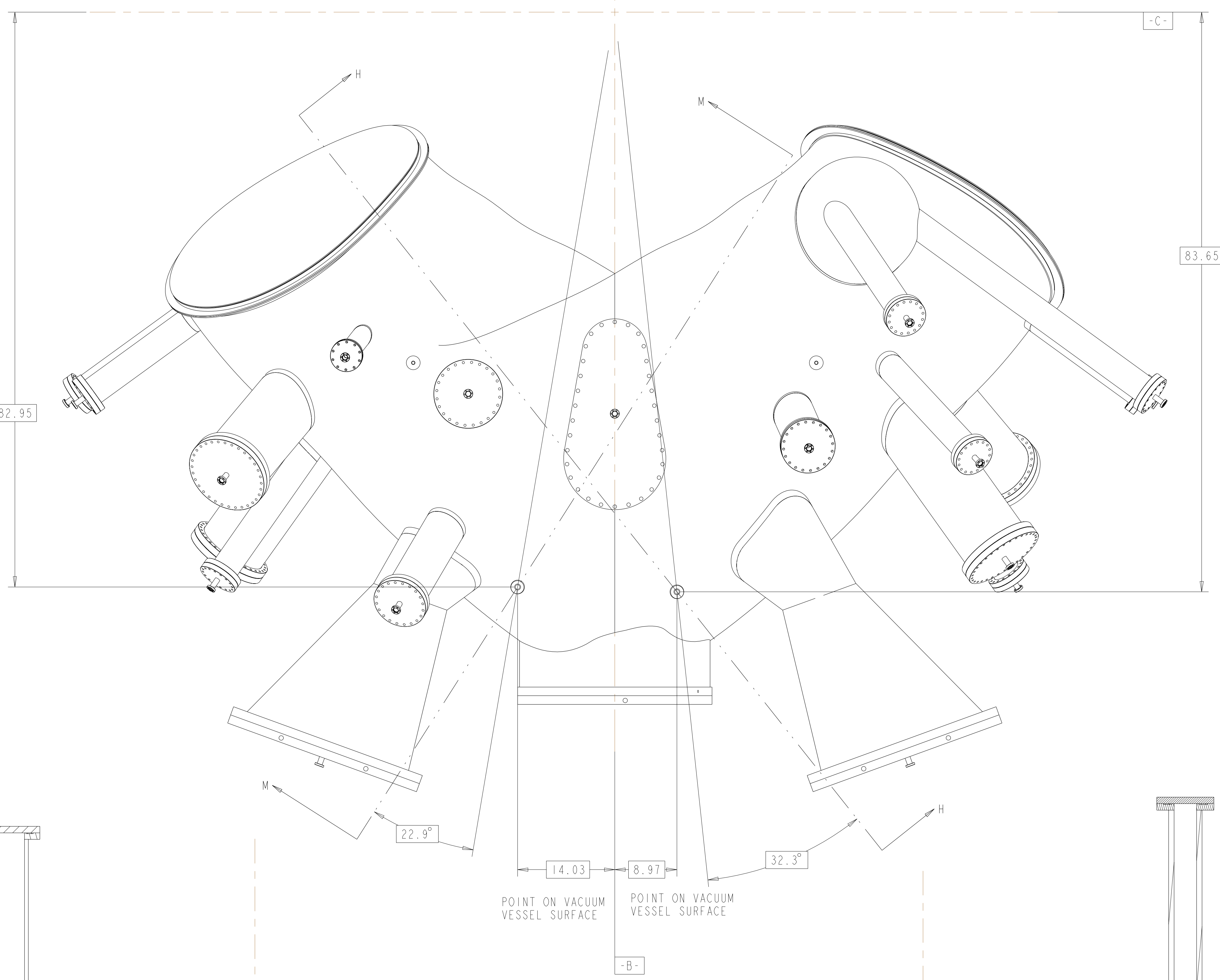

TOP VIEW

FOR PARTS LIST AND NOTES SEE SHEET 1.

POINT ON VACUUM VESSEL SURFACE

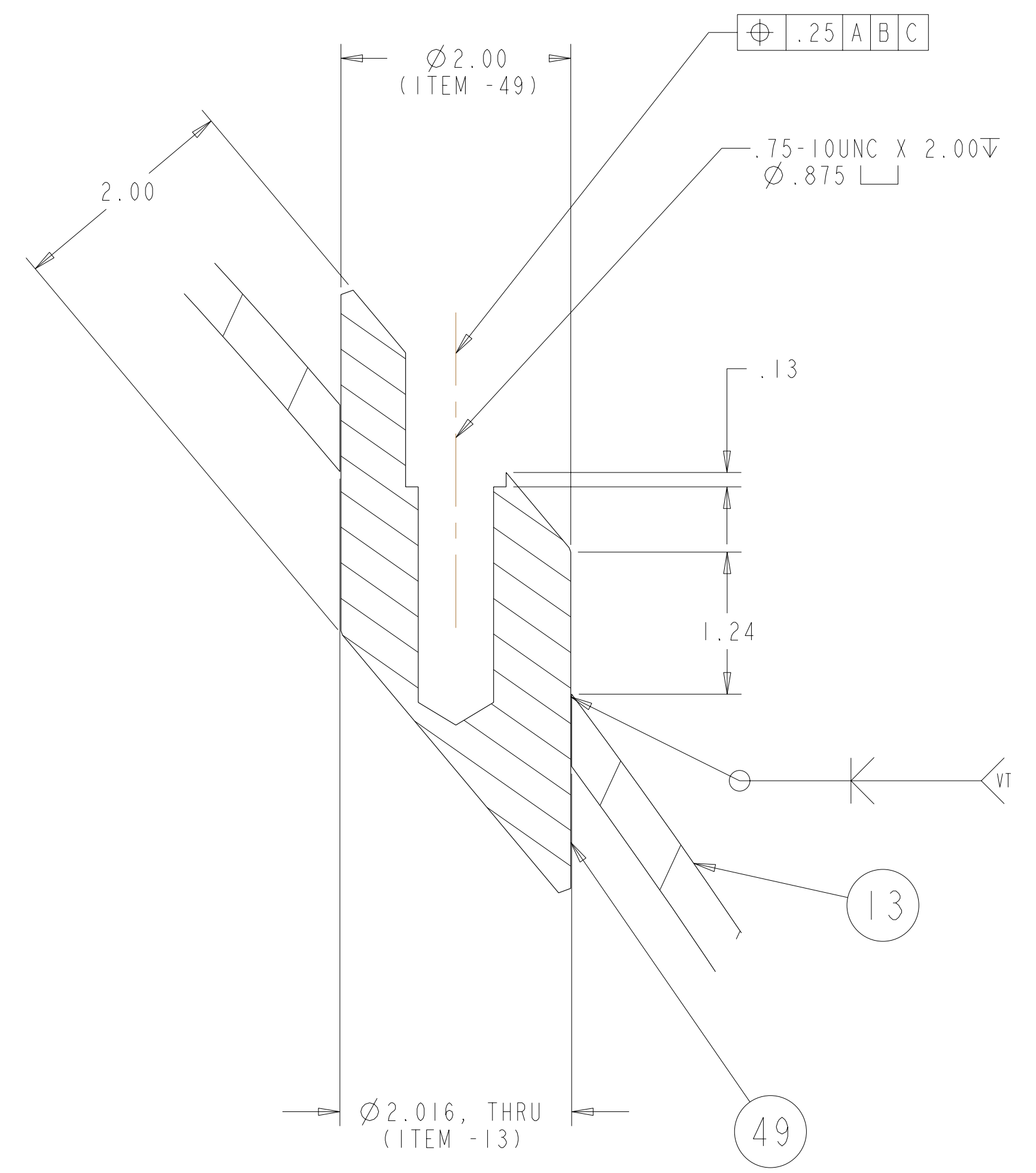

DETAIL Y  
SCALE 1.00

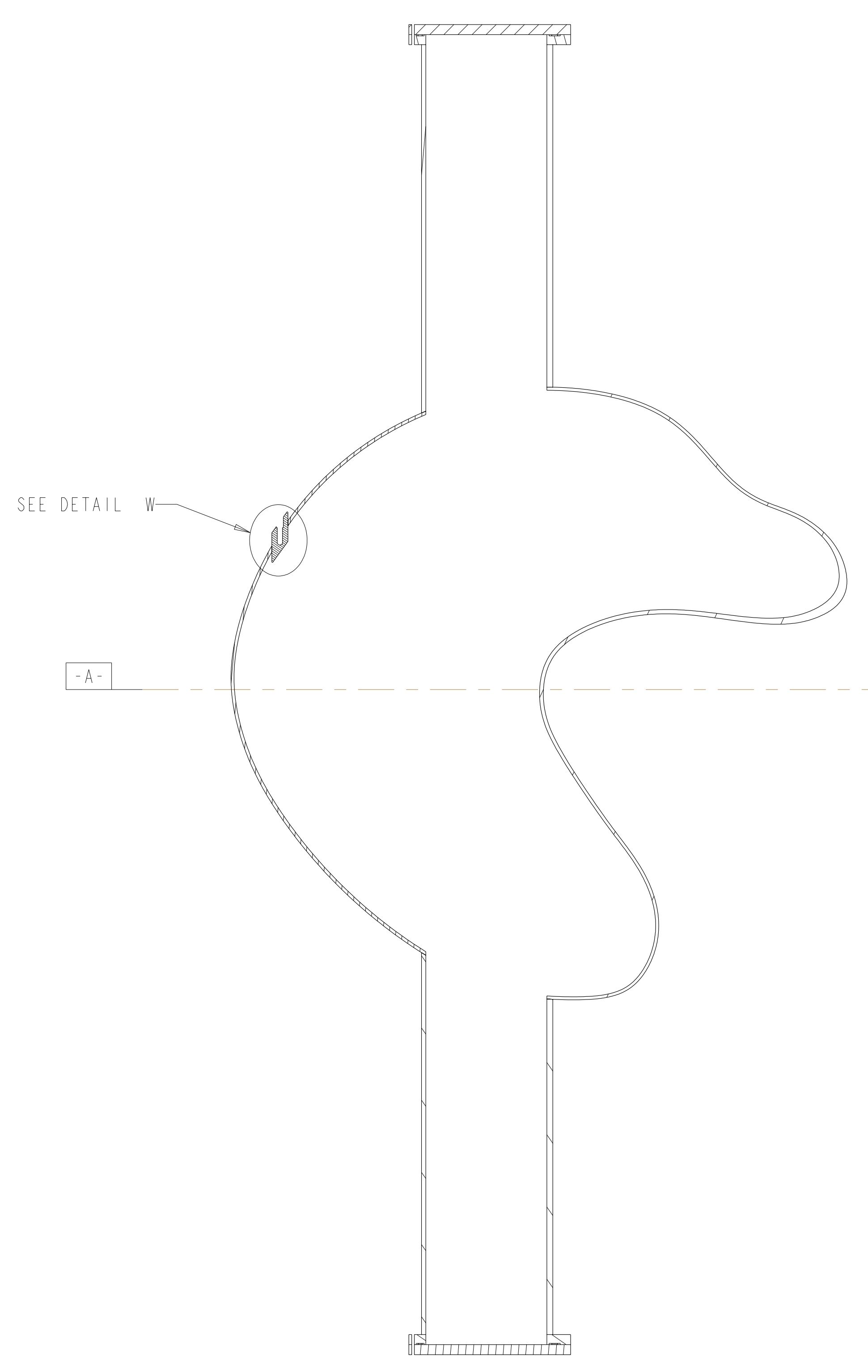

SECTION M-M  
SCALE 0.09

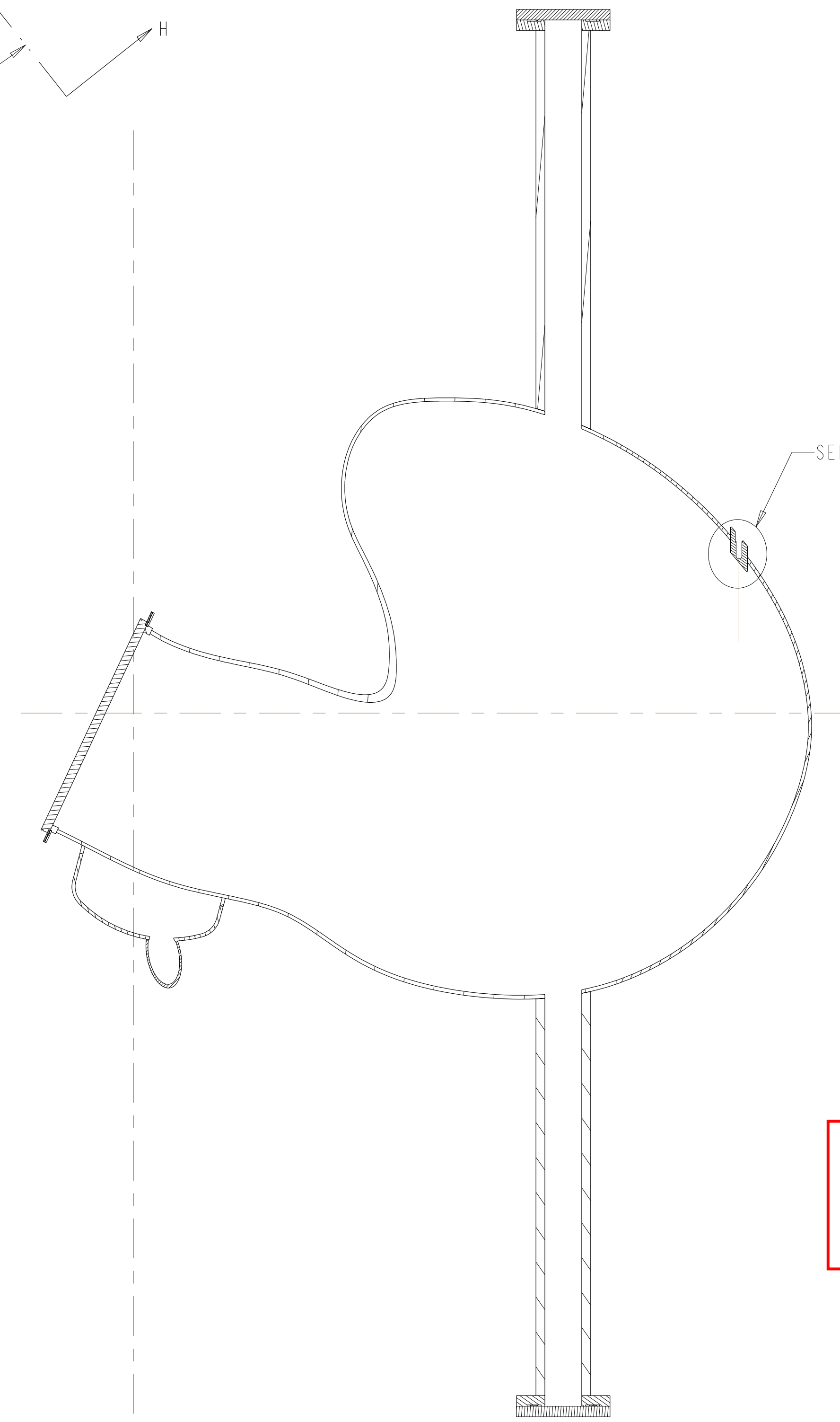

SECTION H-H  
SCALE 0.09

**RELEASED FOR  
FABRICATION / INSTALLATION**  
PPPL Drafting:

Oak Ridge National Laboratory managed for the DEPARTMENT OF ENERGY under U.S. GOVERNMENT contract DE-AC05-00OR22725 UT-BATTELLE, LLC, Oak Ridge, Tennessee PROJECT NAME						
<b>NATIONAL COMPACT STELLARATOR EXPERIMENT</b> <b>VACUUM VESSEL</b> <b>PERIOD INSPECTION AND LEAK CHECK</b> <b>ASSEMBLY</b>						
VERSION NO.	PLANT	BLDG	FL	SHT OF	TYPE	CLASS
5	X-10	5700	3	19 19	A	U
RELEASE LEVEL		SEI20-004			REV	
Fabrication					2	

SEI20-004

A