

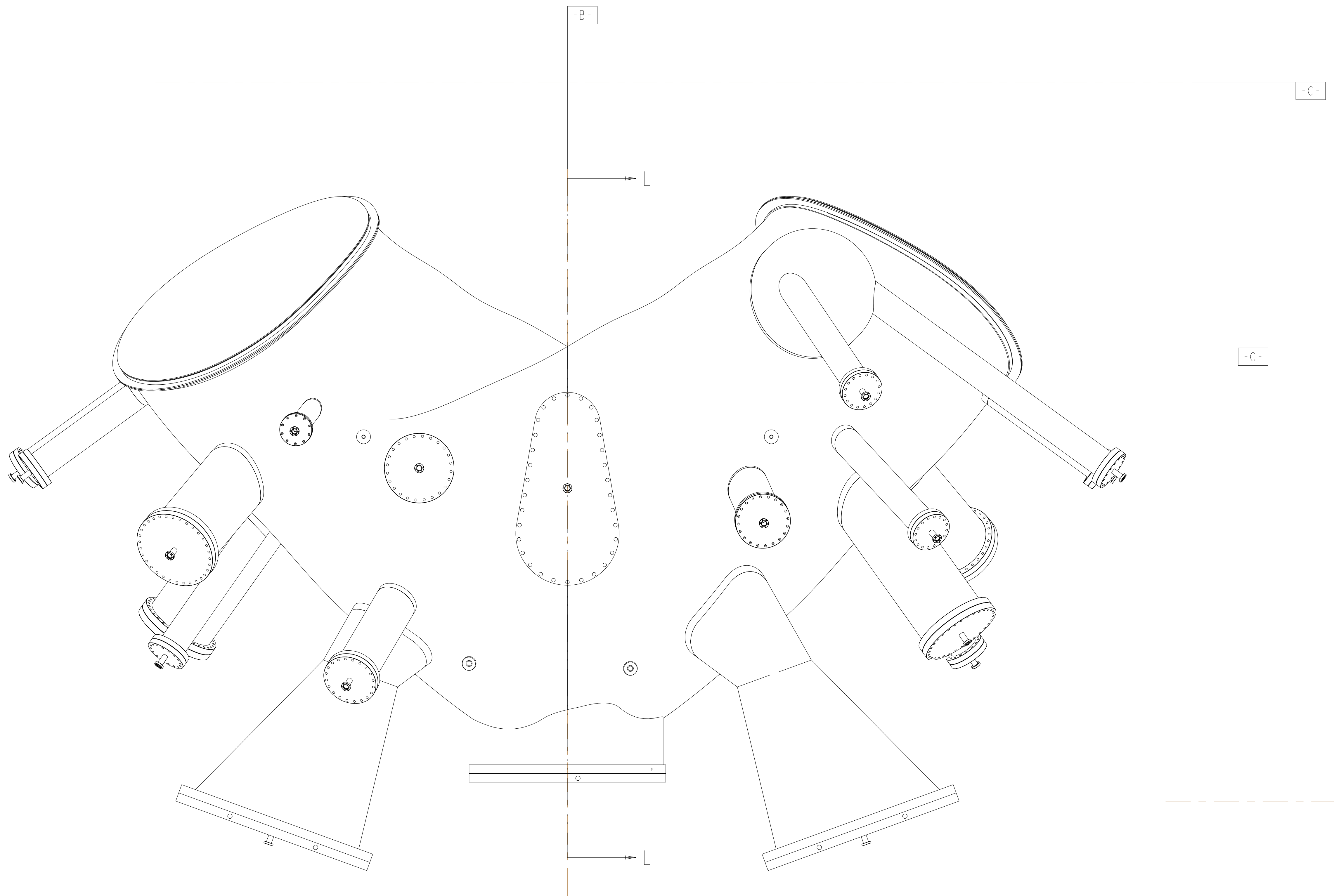

FOR NOTES AND PARTS LIST SEE SHEET 1

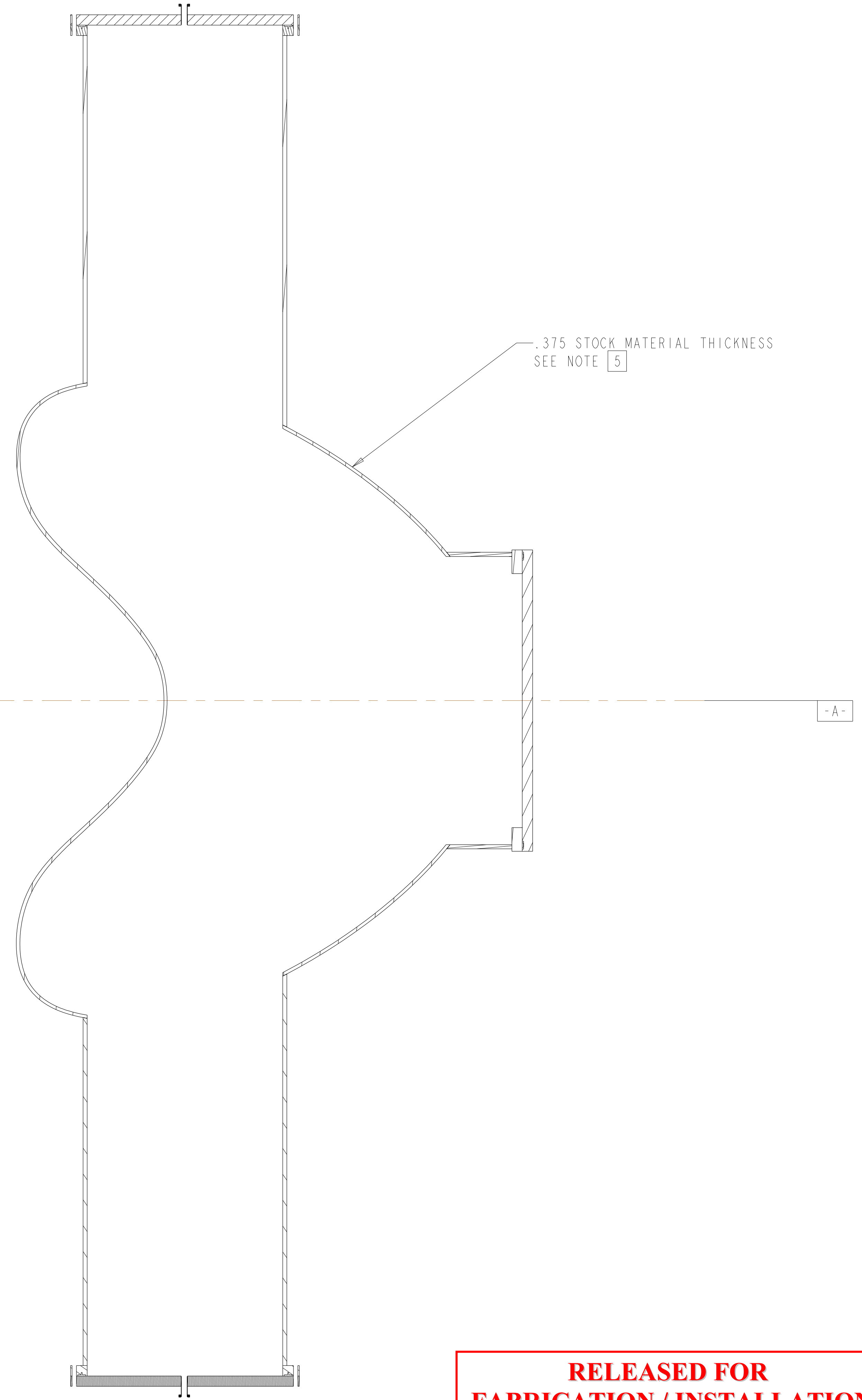

TOP VIEW



SECTION L-L  
 VESSEL THICKNESS

**RELEASED FOR  
 FABRICATION / INSTALLATION**  
 PPPL Drafting:

Oak Ridge National Laboratory managed for the DEPARTMENT OF ENERGY under U.S. GOVERNMENT contract DE-AC05-00OR22725 UT-BATTELLE, LLC, Oak Ridge, Tennessee PROJECT NAME						
NATIONAL COMPACT STELLERATOR EXPERIMENT VACUUM VESSEL PERIOD INSPECTION AND LEAK CHECK ASSEMBLY						
VERSION NO.	PLANT	BLDG	FL	SHT OF	TYPE	CLASS
5	X-10	5700	3	2 19	A	U
RELEASE LEVEL		SE120-004			REV	
Fabrication					2	

H  
G  
F  
E  
D  
C  
B  
A

FOR NOTES AND PARTS LIST SEE SHEET 1

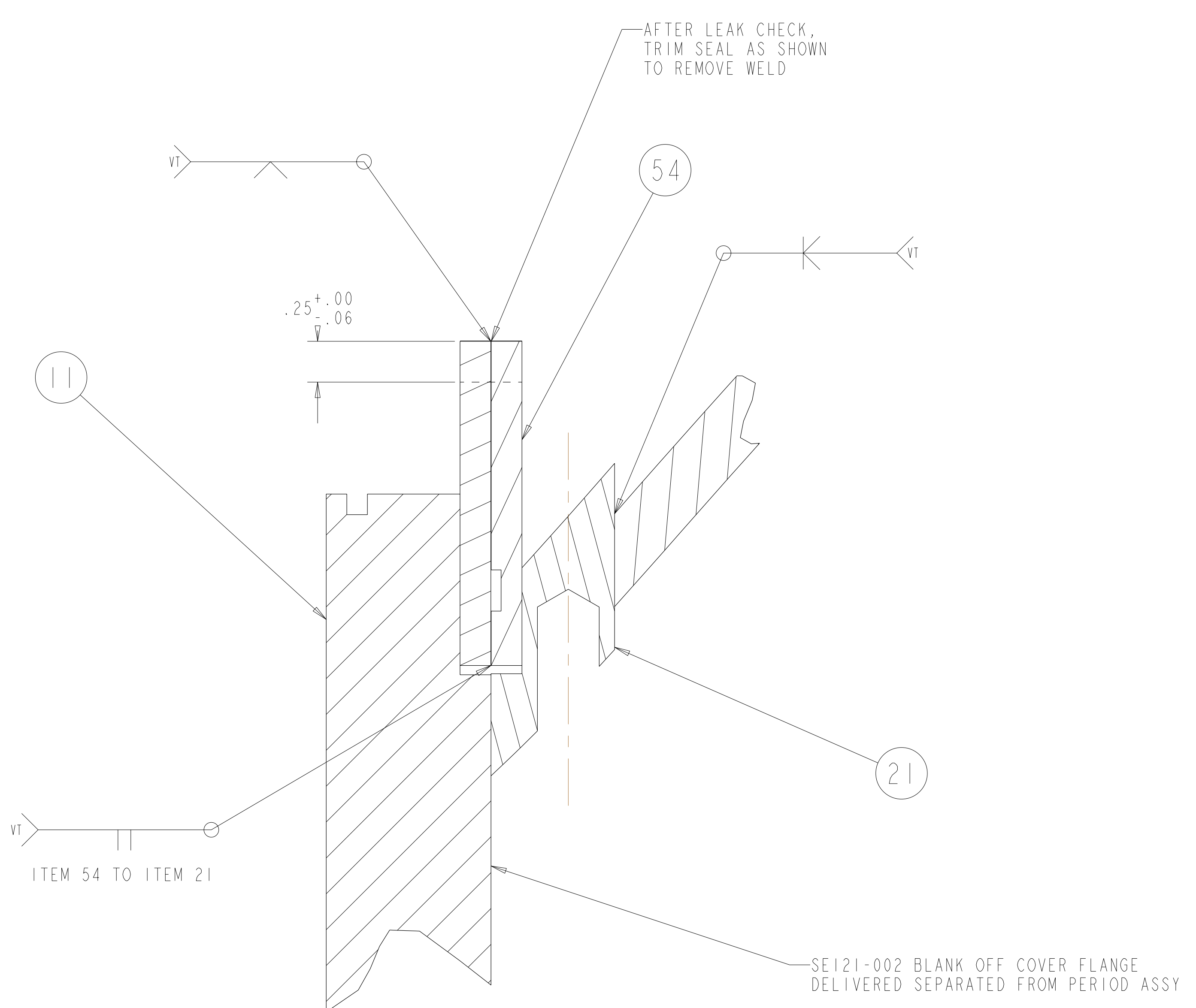
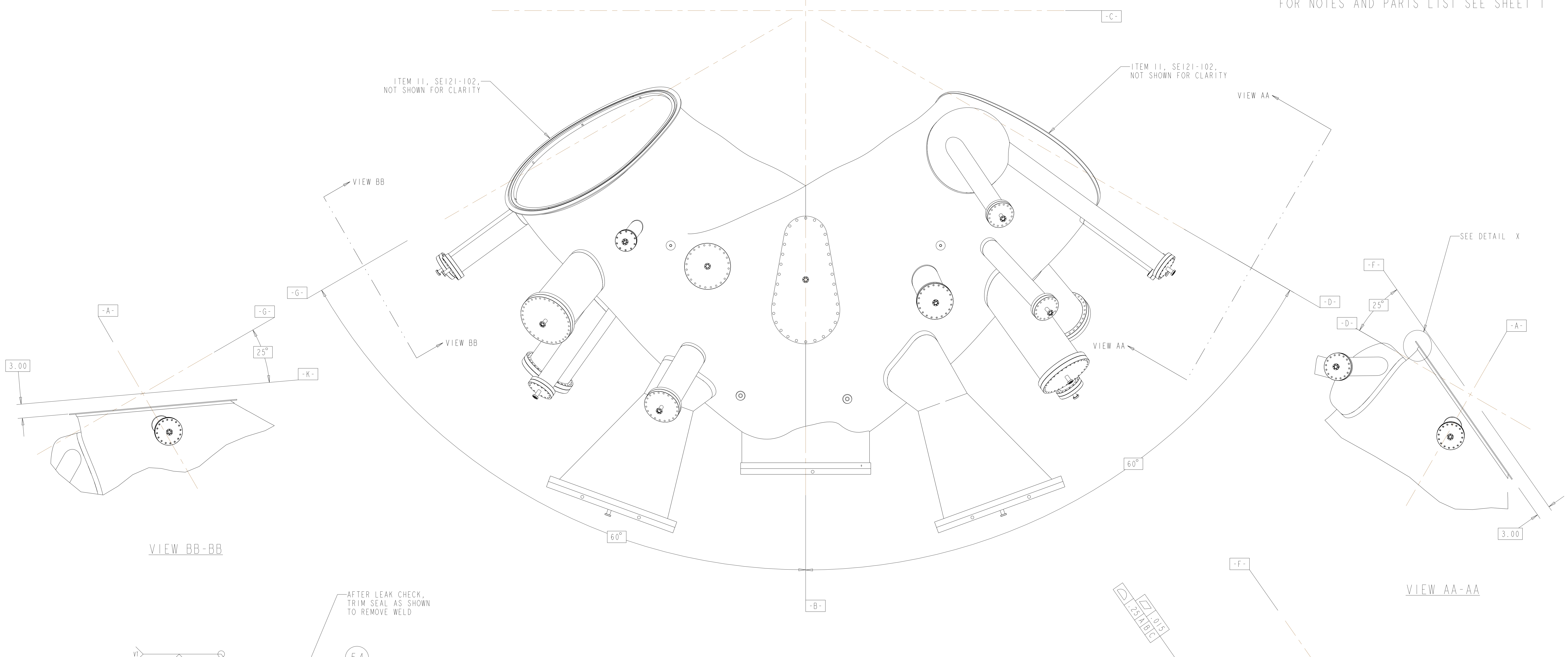

SEE DRAWING SE121-013.DRW FOR ADDITIONAL DETAILS FOR THE VACUUM VESSEL FLANGE. DIMENSIONS ON DRAWING SE121-013.DRW APPLY AS IF THEY WERE DETAILED ON THIS SHEET.

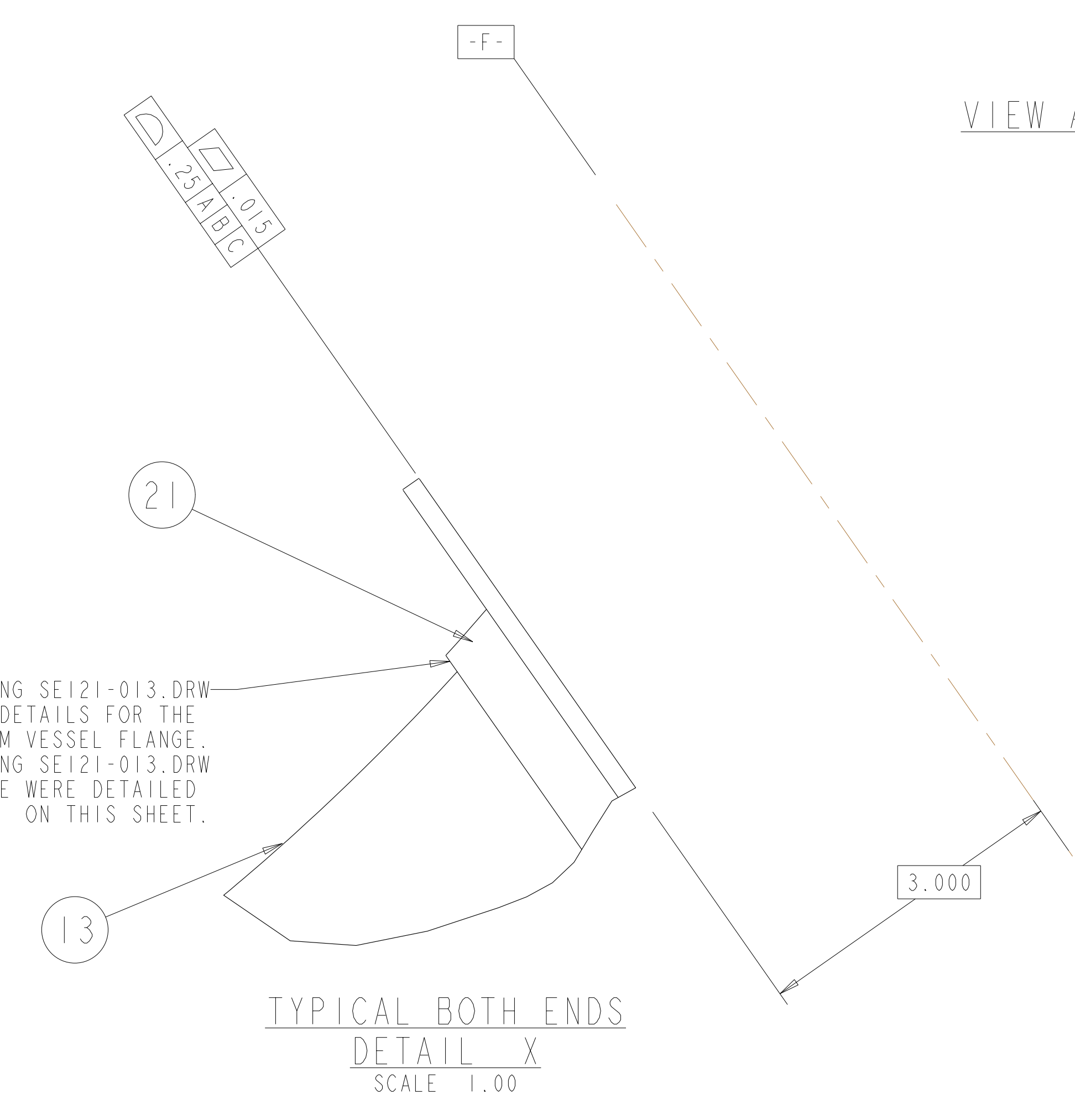

**RELEASED FOR FABRICATION / INSTALLATION**  
PPPL Drafting:

UT-BATTELLE		Oak Ridge National Laboratory managed for the DEPARTMENT OF ENERGY under U.S. GOVERNMENT contract DE-AC05-00OR22725 UT-BATTELLE, LLC, Oak Ridge, Tennessee					
PROJECT NAME							
NATIONAL COMPACT STELLARATOR EXPERIMENT							
VACUUM VESSEL							
PERIOD INSPECTION AND LEAK CHECK							
ASSEMBLY							
VERSION NO.	PLANT	BLDG	FL	SHT OF	TYPE	CLASS	
5	X-10	5700	3	3 19	A	U	
RELEASE LEVEL	Fabrication						
SE120-004						REV	2

FOR PARTS LIST AND NOTES SEE SHEET 1.

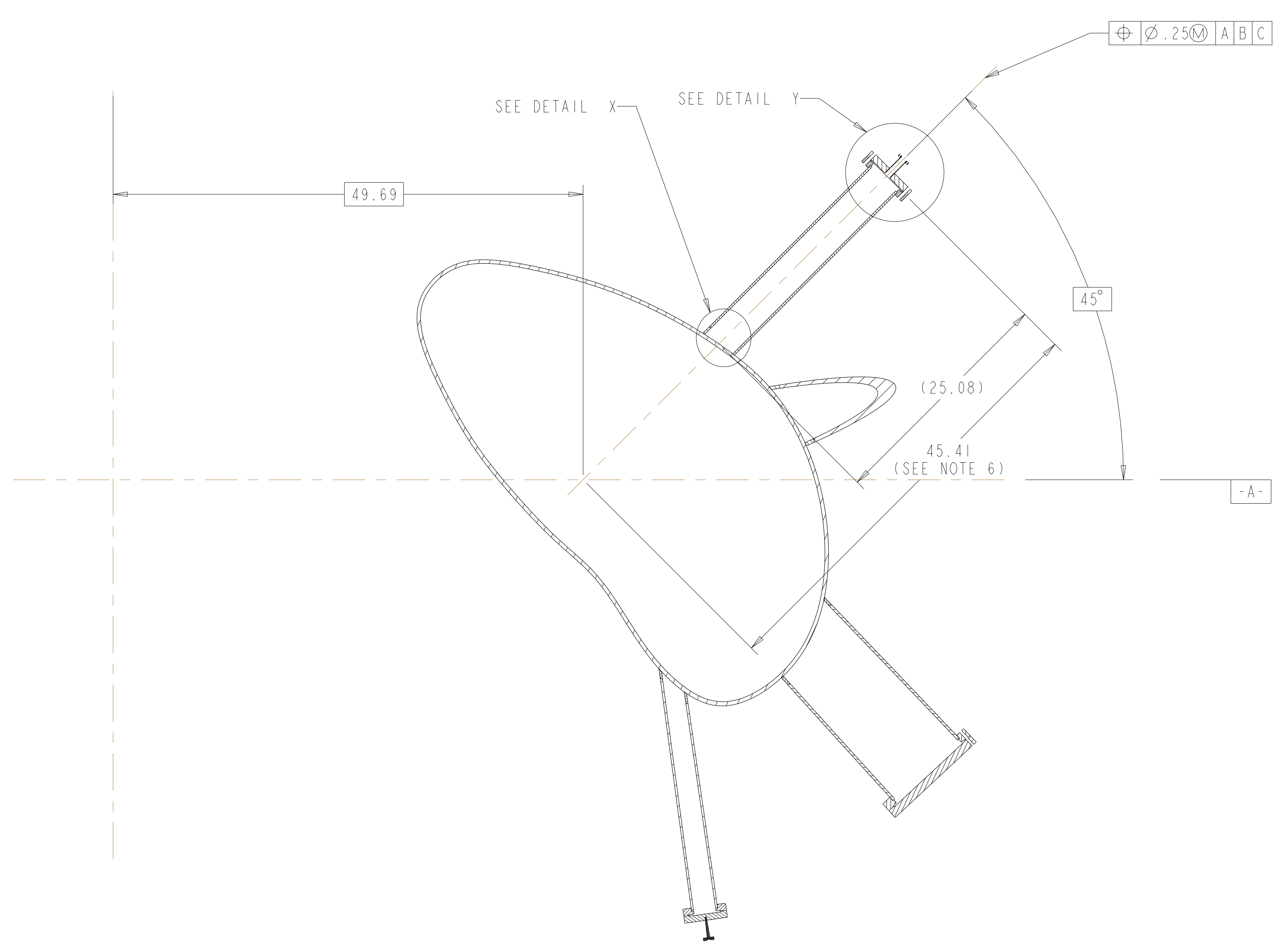
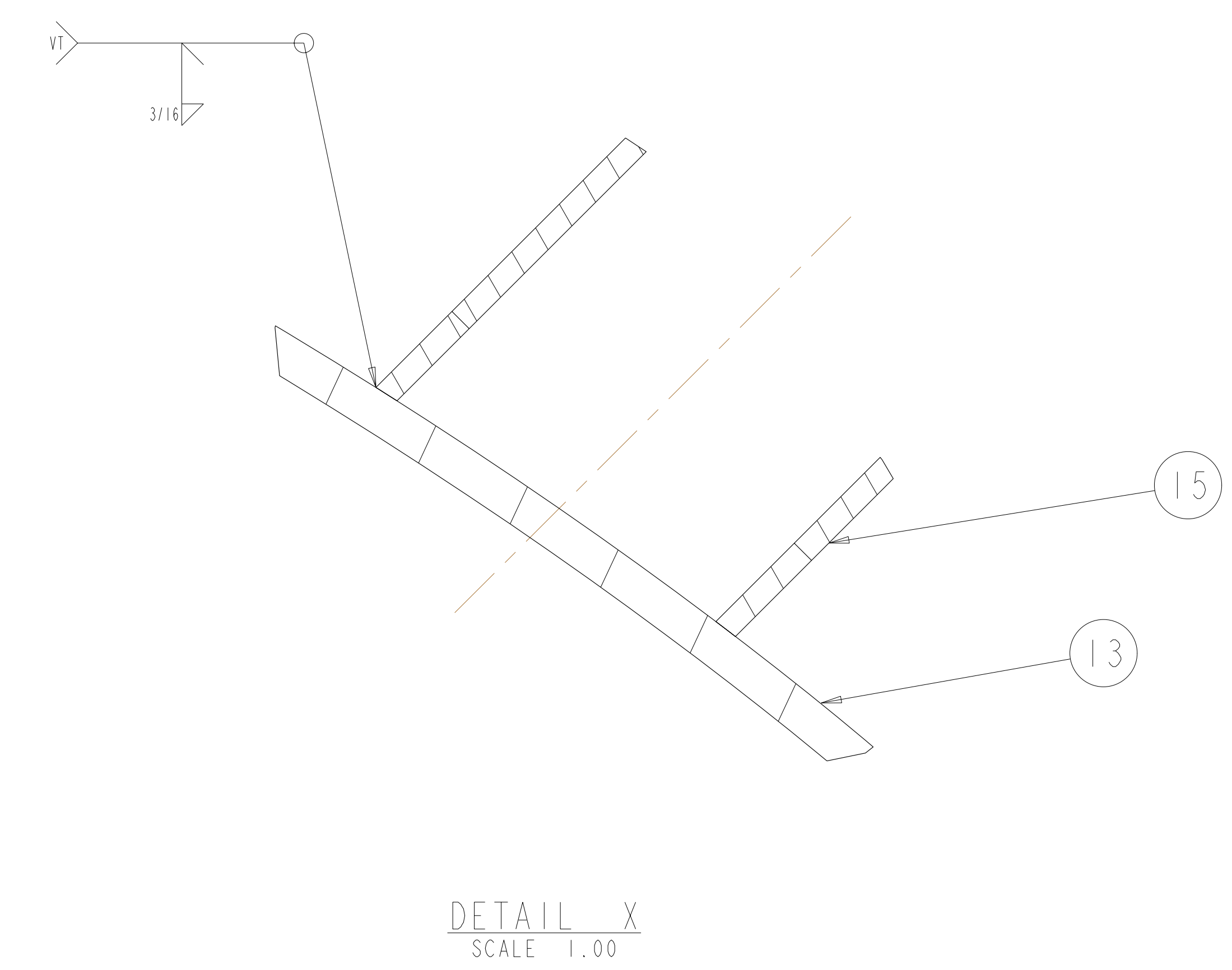
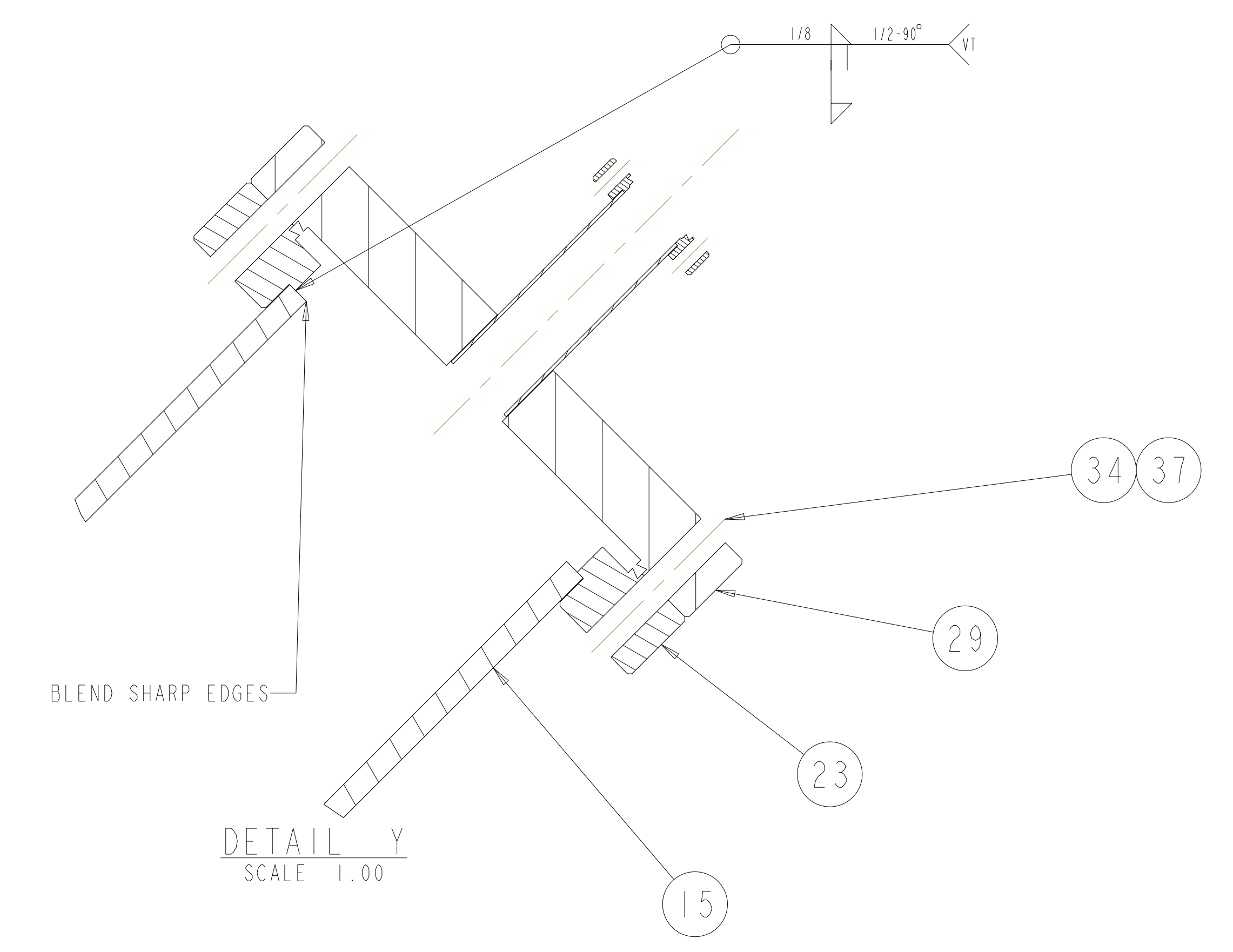
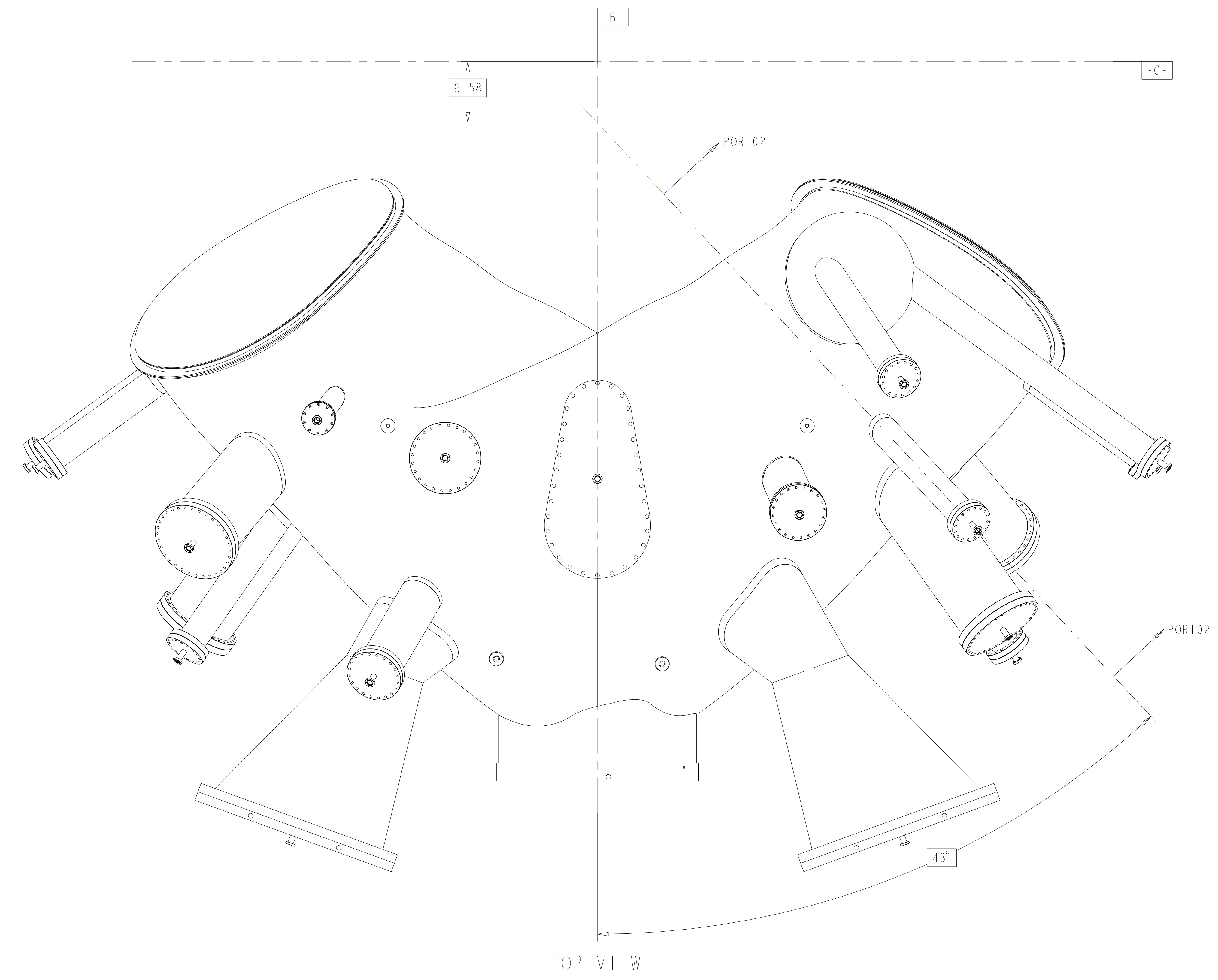

TYPICAL PORT 2A AND 2B SECTION PORT02-PORT02

**RELEASED FOR FABRICATION / INSTALLATION**  
 PPPL Drafting:

UT-BATTELLE		Oak Ridge National Laboratory managed for the DEPARTMENT OF ENERGY under U.S. GOVERNMENT contract DE-AC05-00OR22725 UT-BATTELLE, LLC, Oak Ridge, Tennessee					
NATIONAL COMPACT STELLARATOR EXPERIMENT							
VACUUM VESSEL							
PERIOD INSPECTION AND LEAK CHECK ASSEMBLY							
VERSION NO.	PLANT	BLDG	FL	SHT OF	TYPE	CLASS	
5	X-10	5700	3	4	19	A	U
RELEASE LEVEL	SE120-004						REV
Fabrication							2

H  
G  
F  
E  
D  
C  
B  
A

SE120-004

FOR PARTS LIST AND NOTES SEE SHEET 1.

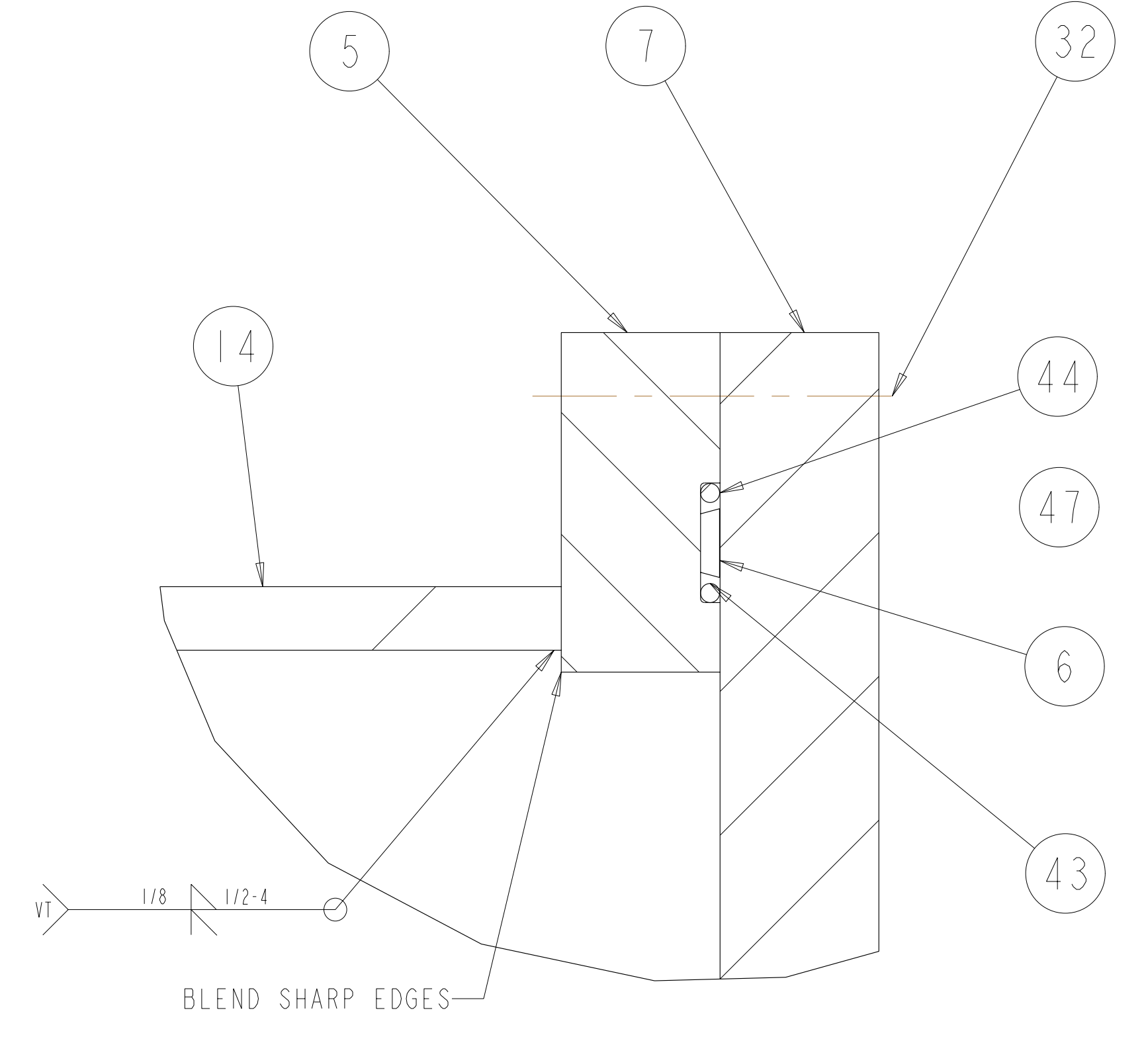
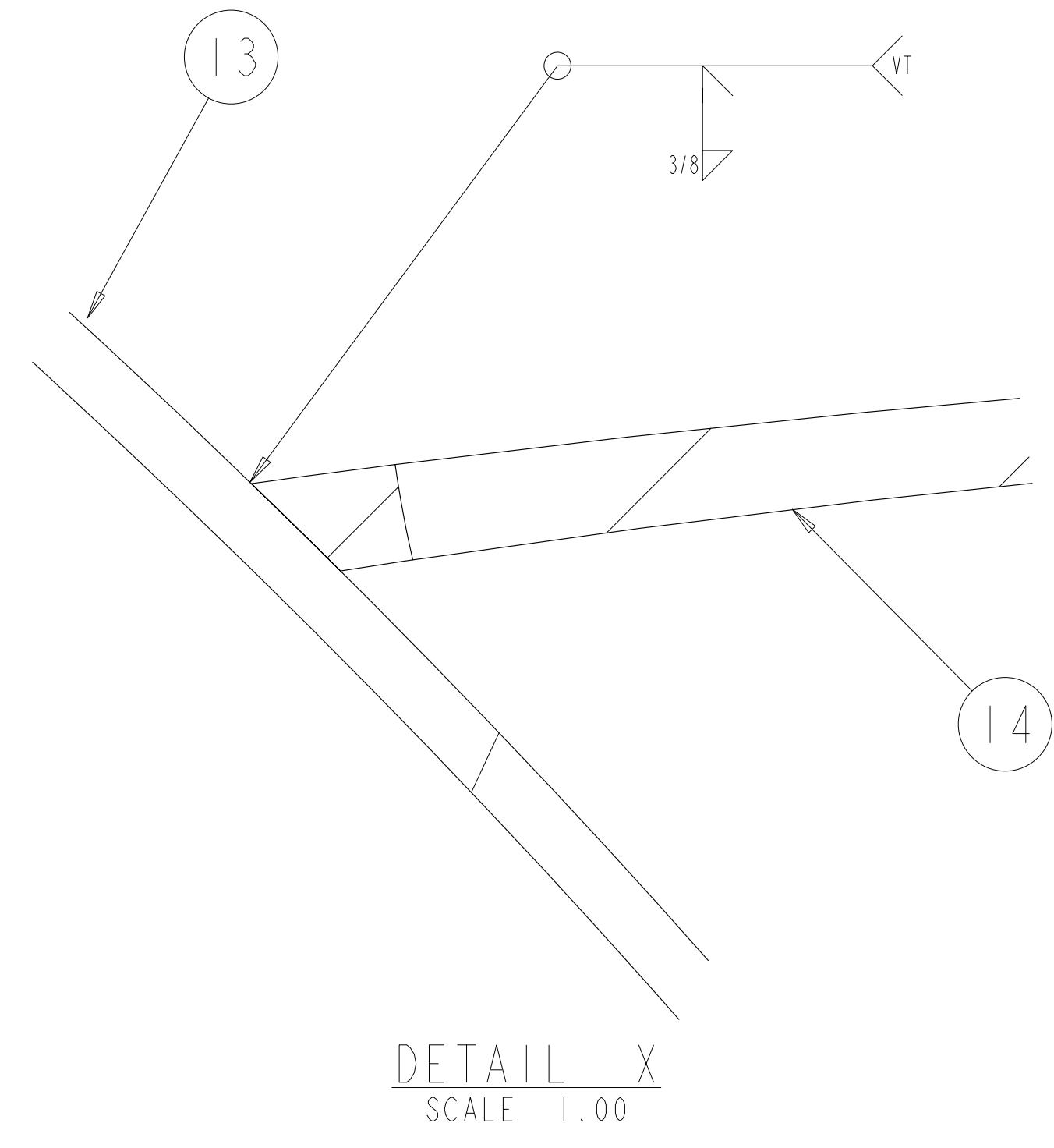
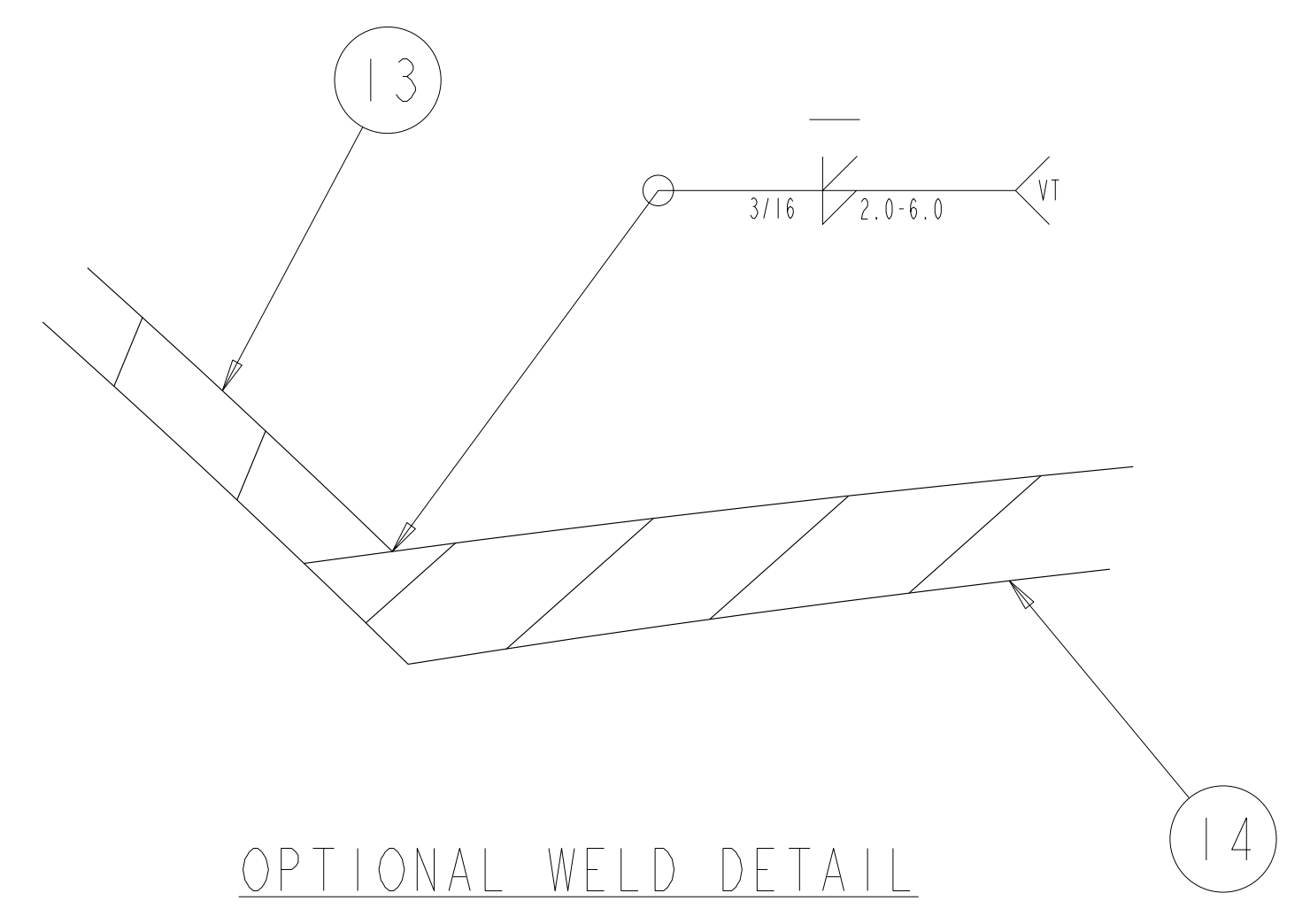
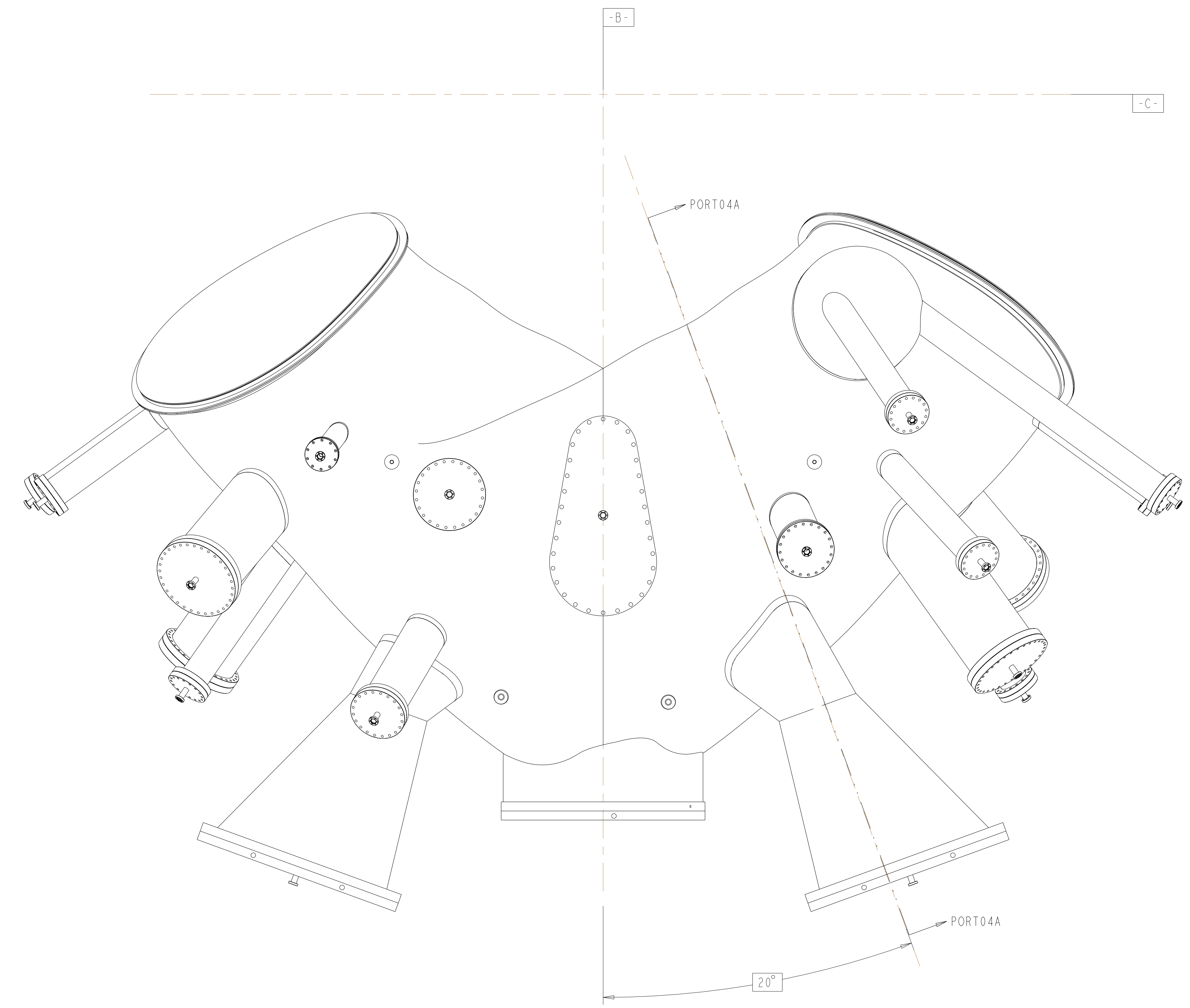

TOP VIEW

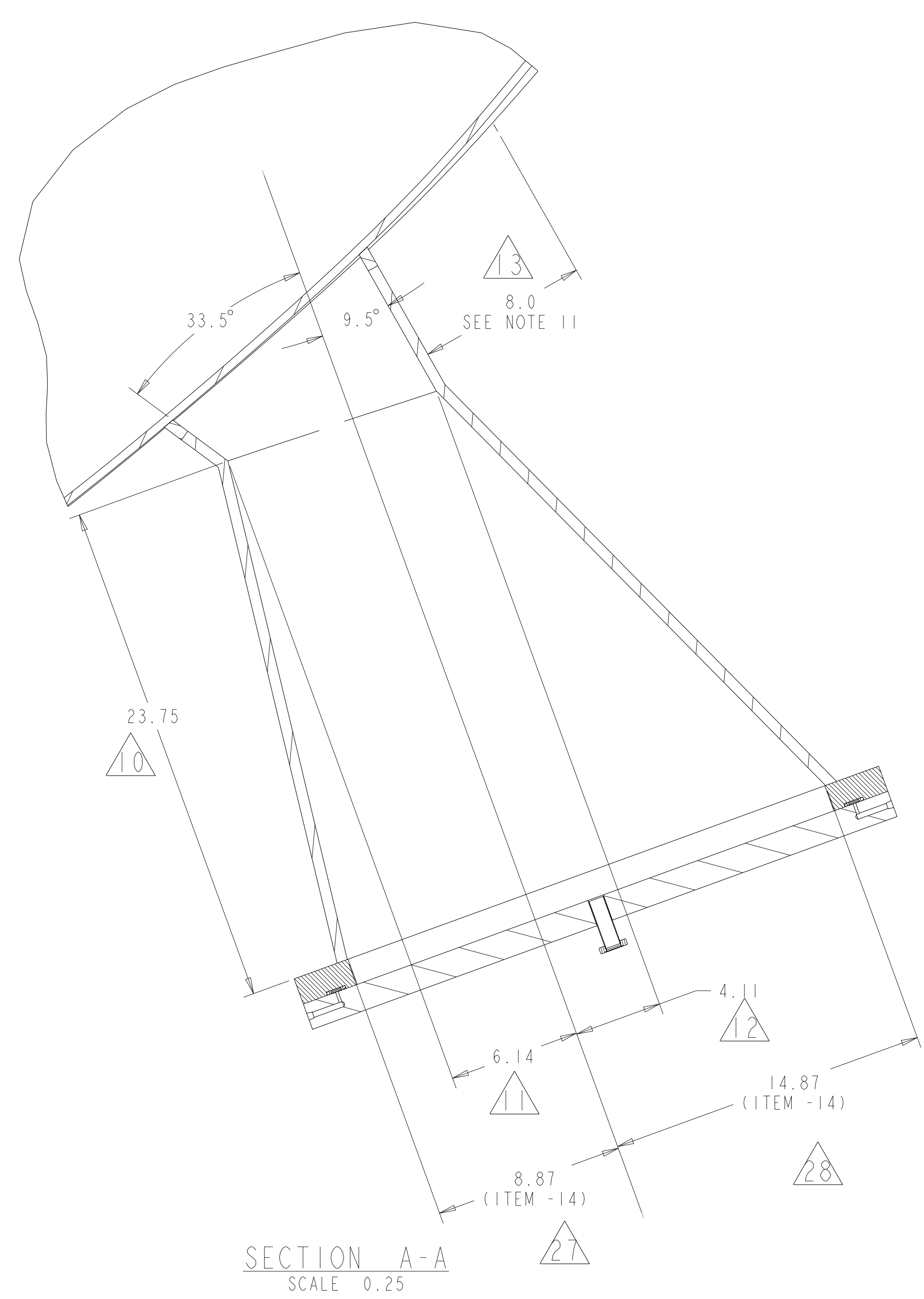
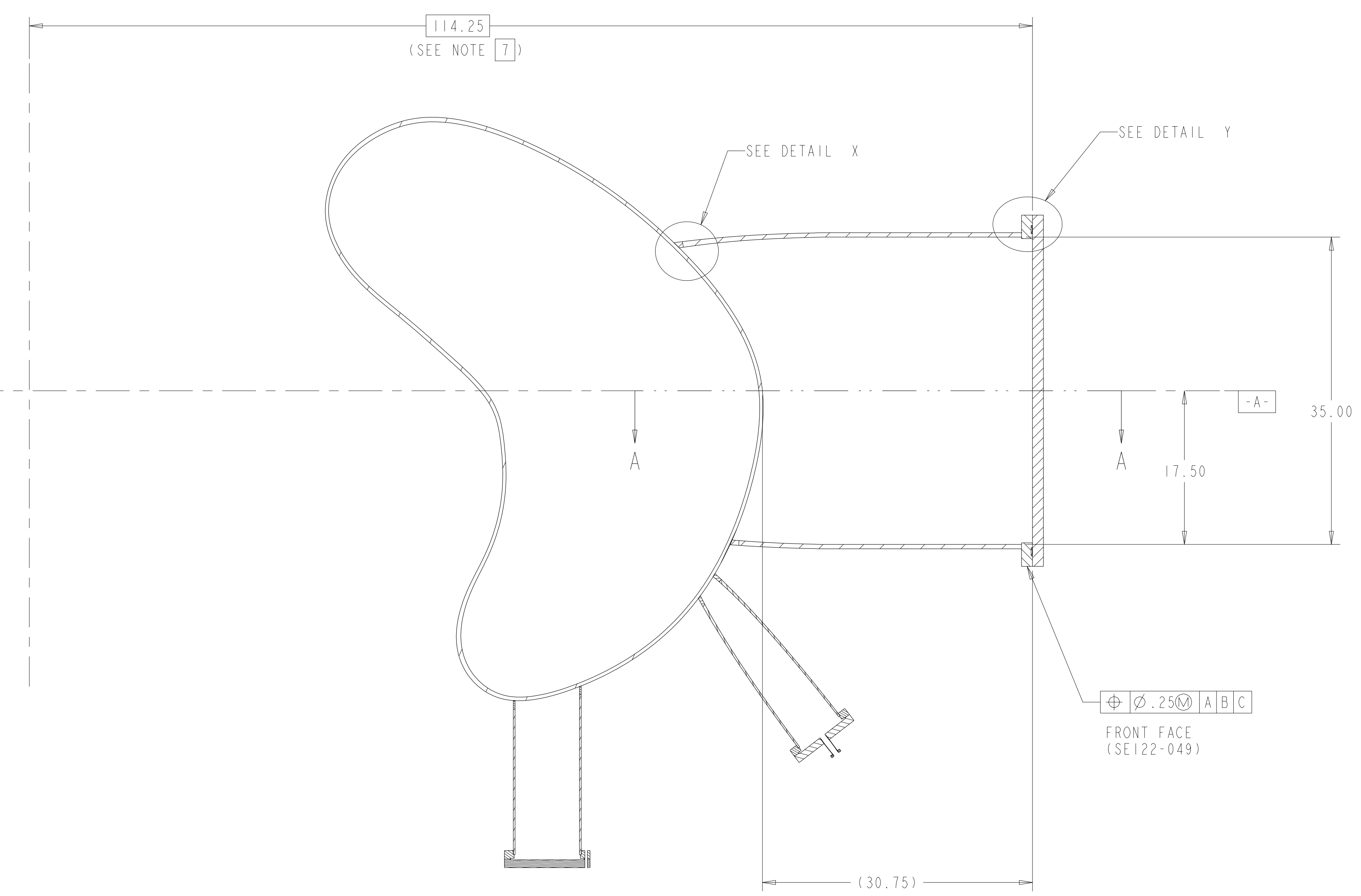

**RELEASED FOR FABRICATION / INSTALLATION**  
 PPPL Drafting:

TYPICAL PORT 4A AND 4B SECTION PORT04A-PORT04A

UT-BATTELLE		Oak Ridge National Laboratory managed for the DEPARTMENT OF ENERGY under U.S. GOVERNMENT contract DE-AC05-00OR22725 UT-BATTELLE, LLC., Oak Ridge, Tennessee	
PROJECT NAME			
NATIONAL COMPACT STELLERATOR EXPERIMENT			
VACUUM VESSEL			
PERIOD INSPECTION AND LEAK CHECK ASSEMBLY			
VERSION NO.	PLANT	BLDG	FL
5	X-10	5700	3
RELEASE LEVEL			
Fabrication			
SHT OF	TYPE	CLASS	
19	A	U	
		REV	
		2	

H  
G  
F  
E  
D  
C  
B  
A

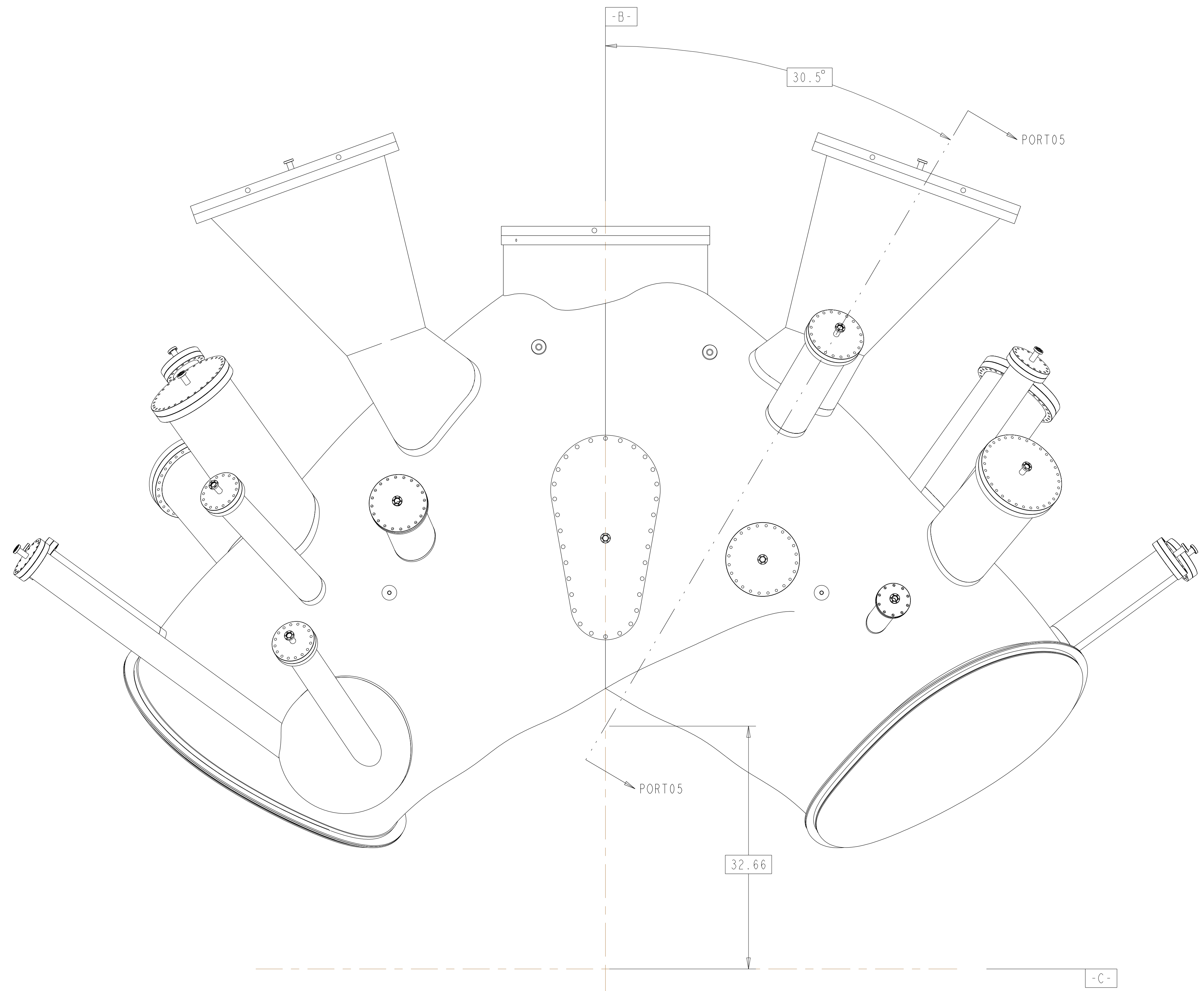

BOTTOM VIEW

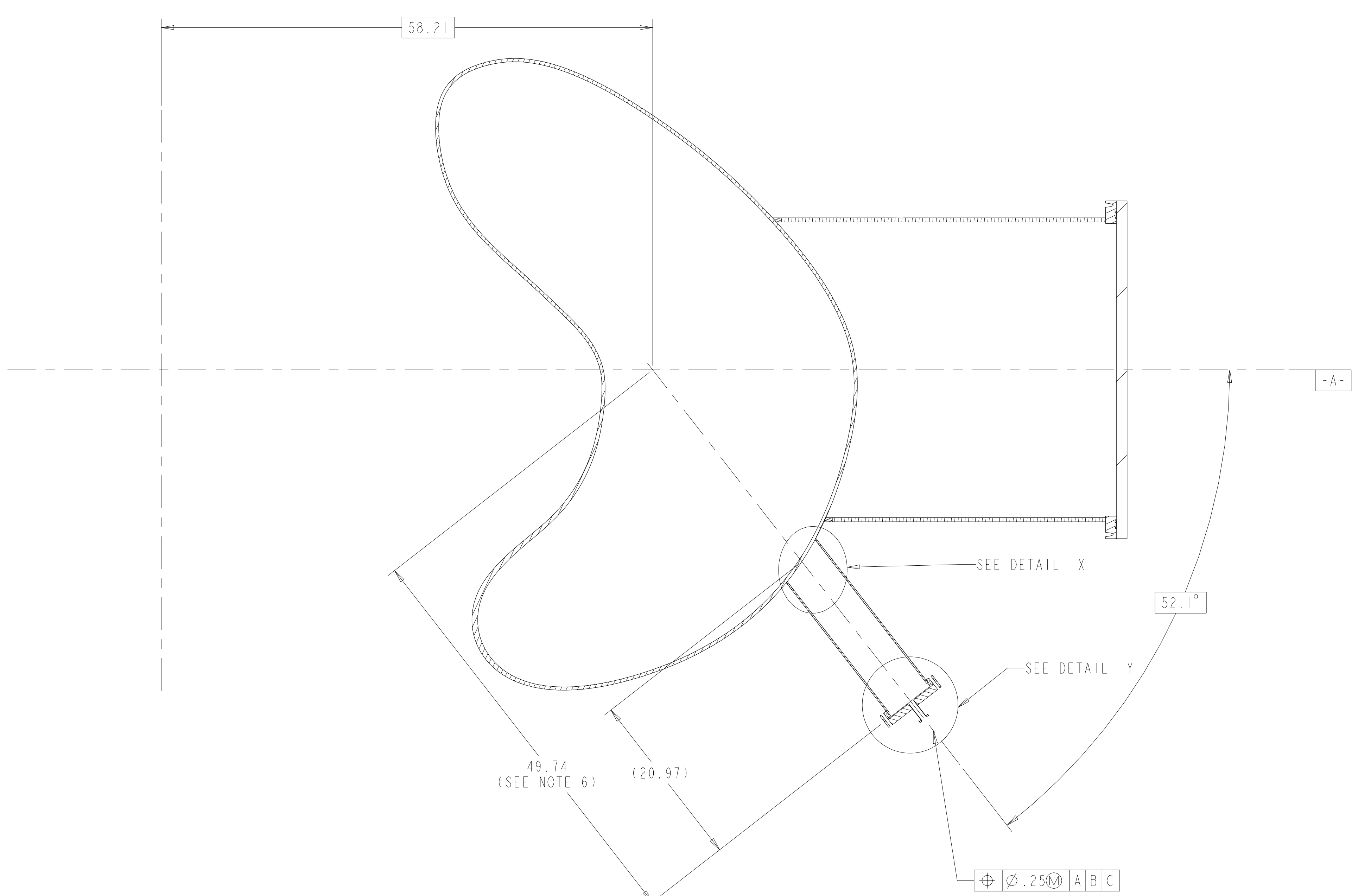

TYPICAL PORT 5A AND 5B SECTION PORT05-PORT05

FOR PARTS LIST AND NOTES SEE SHEET 1.

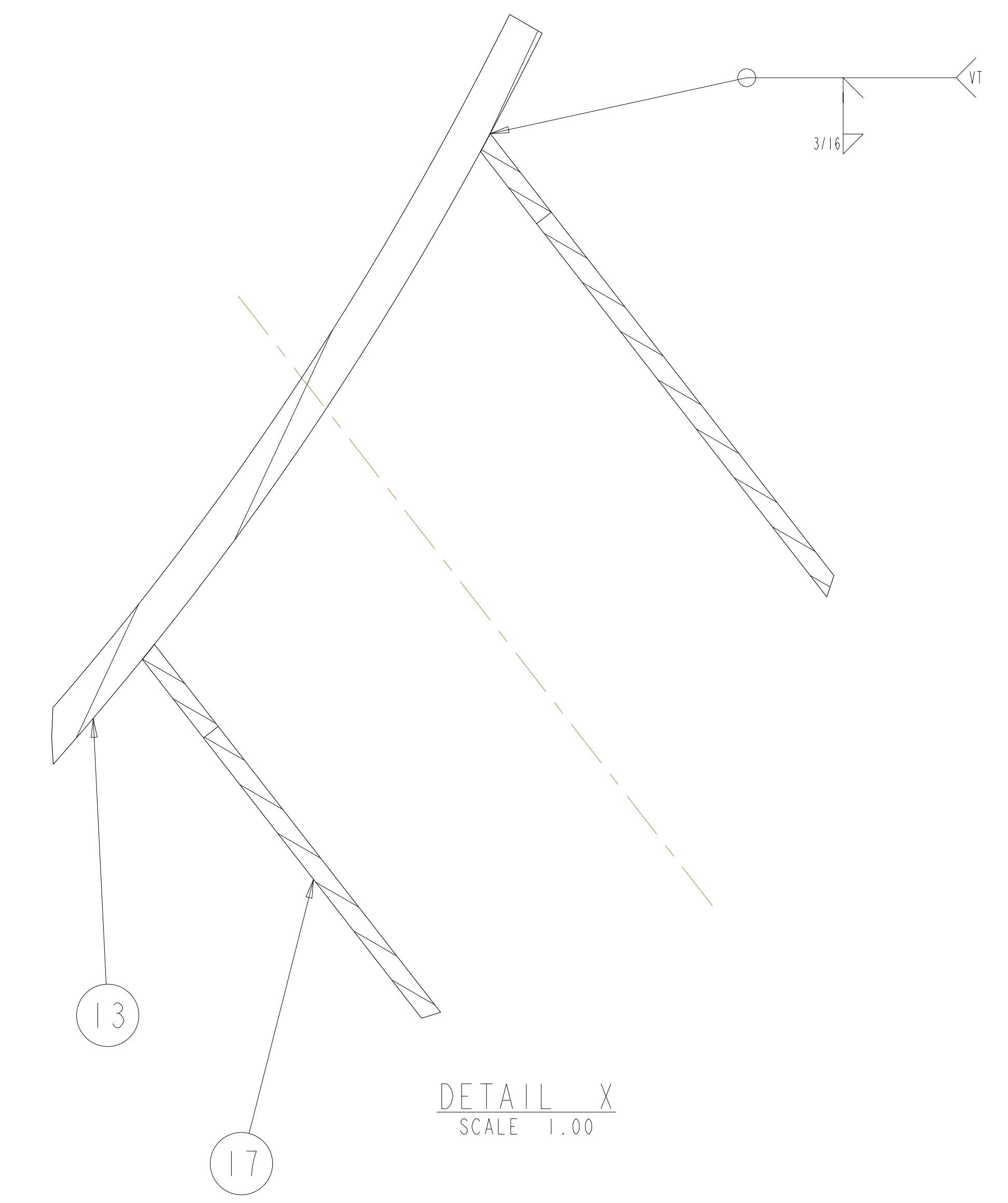

DETAIL X  
SCALE 1.00

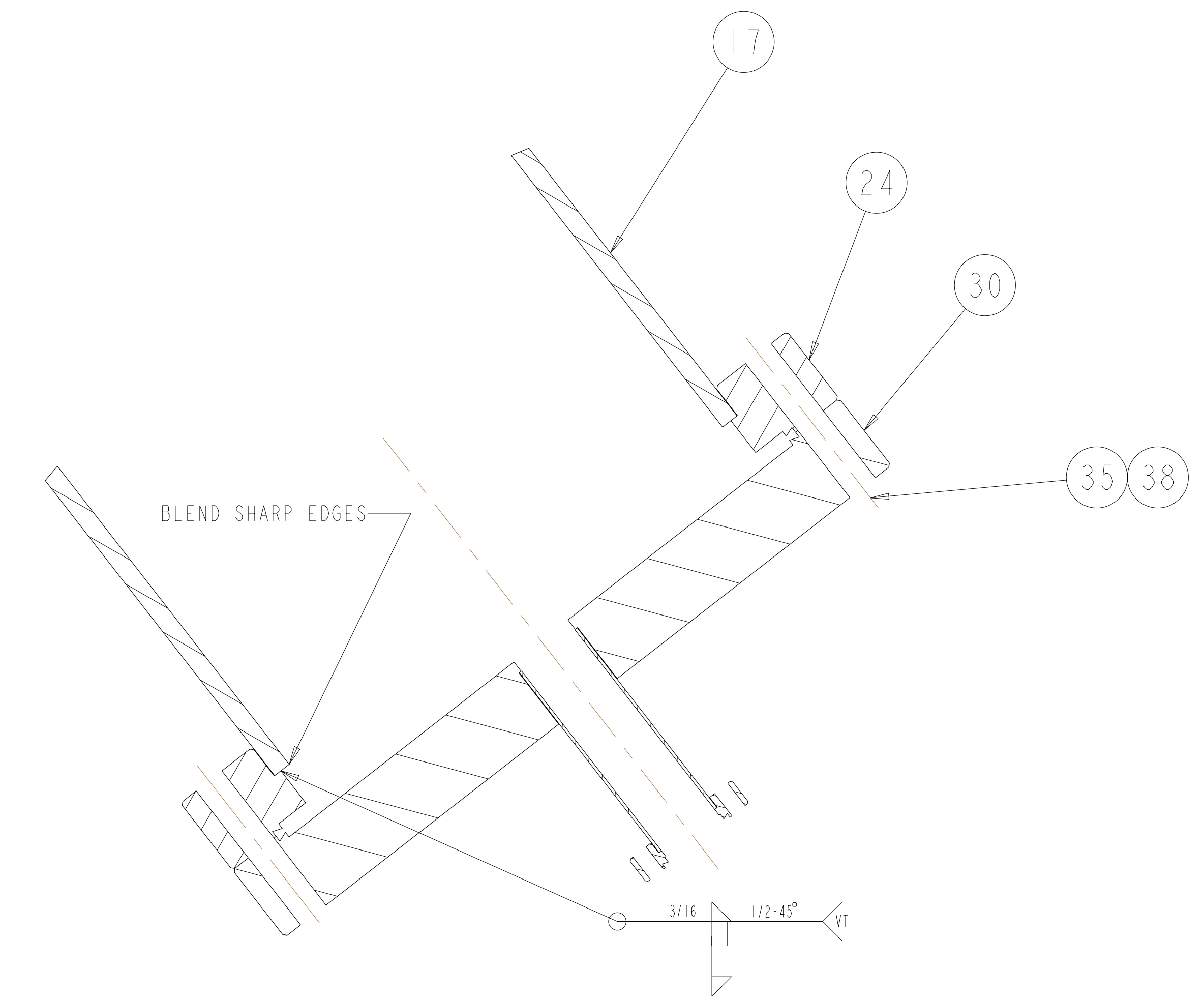

DETAIL Y  
SCALE 1.00

**RELEASED FOR FABRICATION / INSTALLATION**  
 PPPL Drafting:

UT-BATTELLE		Oak Ridge National Laboratory managed for the DEPARTMENT OF ENERGY under U.S. GOVERNMENT contract DE-AC05-00OR22725 UT-BATTELLE, LLC, Oak Ridge, Tennessee						
PROJECT NAME								
NATIONAL COMPACT STELLARATOR EXPERIMENT								
VACUUM VESSEL								
PERIOD INSPECTION AND LEAK CHECK ASSEMBLY								
VERSION NO.	PLANT	BLDG	FL	SHT OF	TYPE	CLASS		
5	X-10	5700	3	6	19	A	U	
RELEASE LEVEL		SE120-004					REV	
Fabrication							2	

H  
G  
F  
E  
D  
C  
B  
A

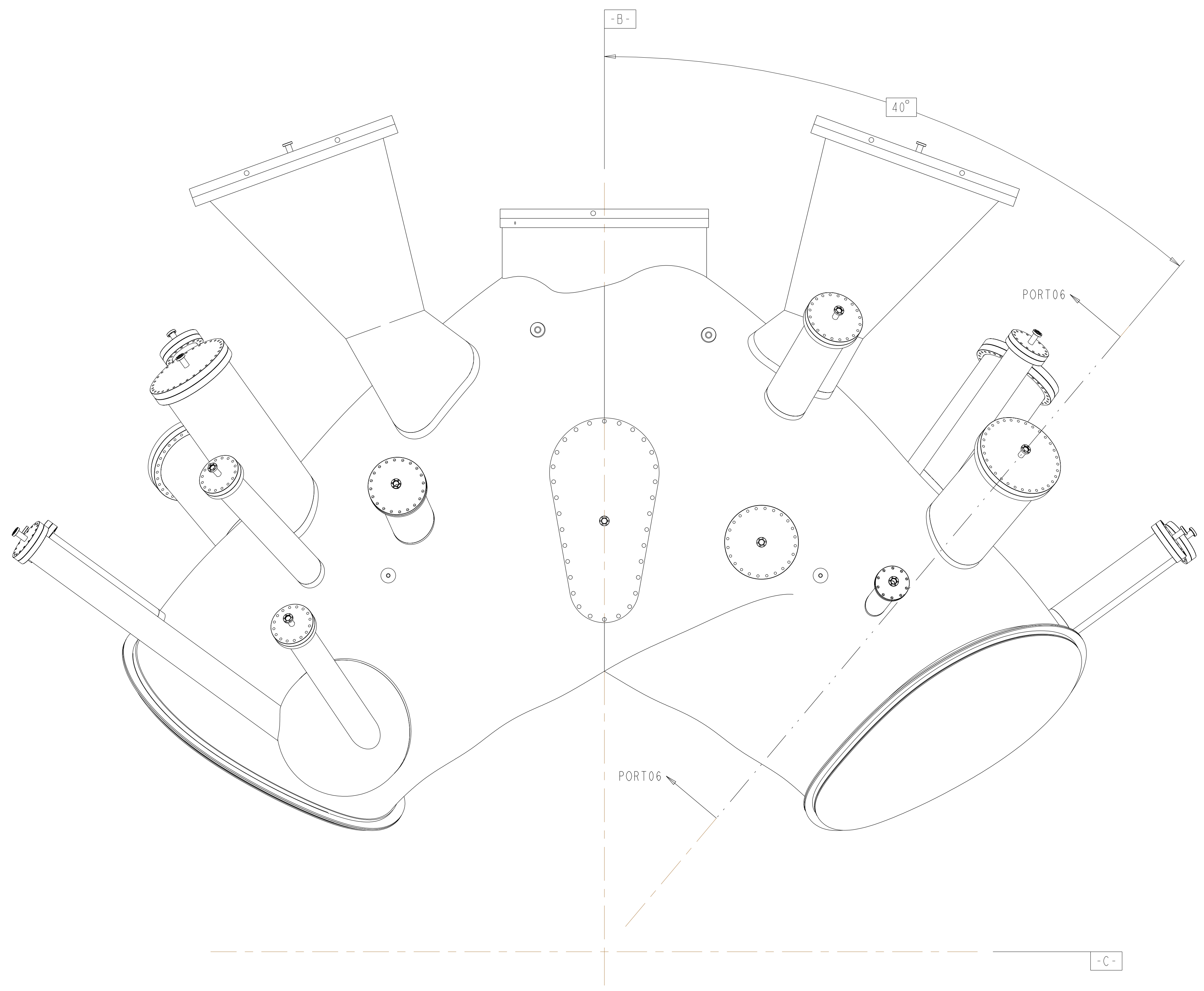

BOTTOM VIEW

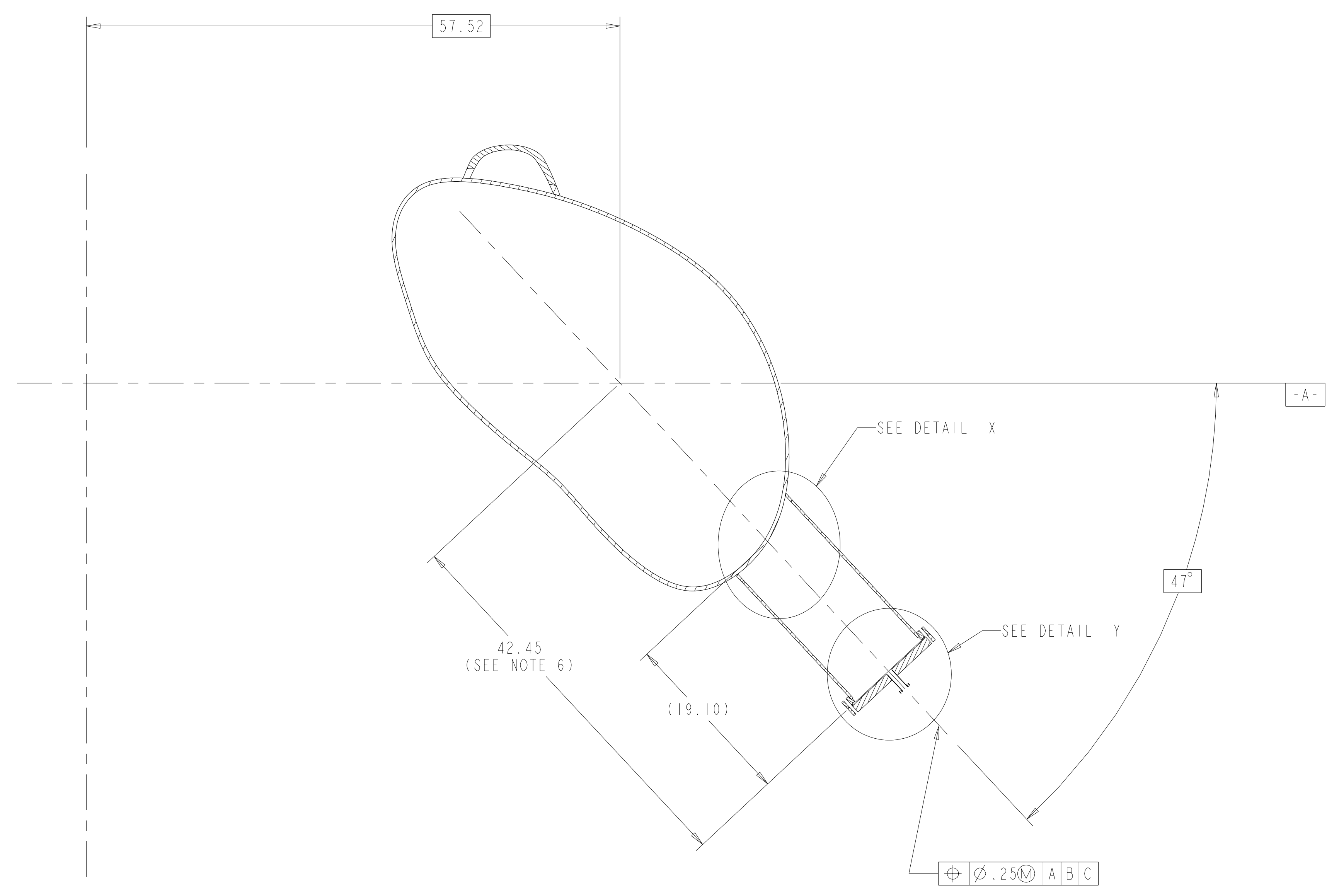
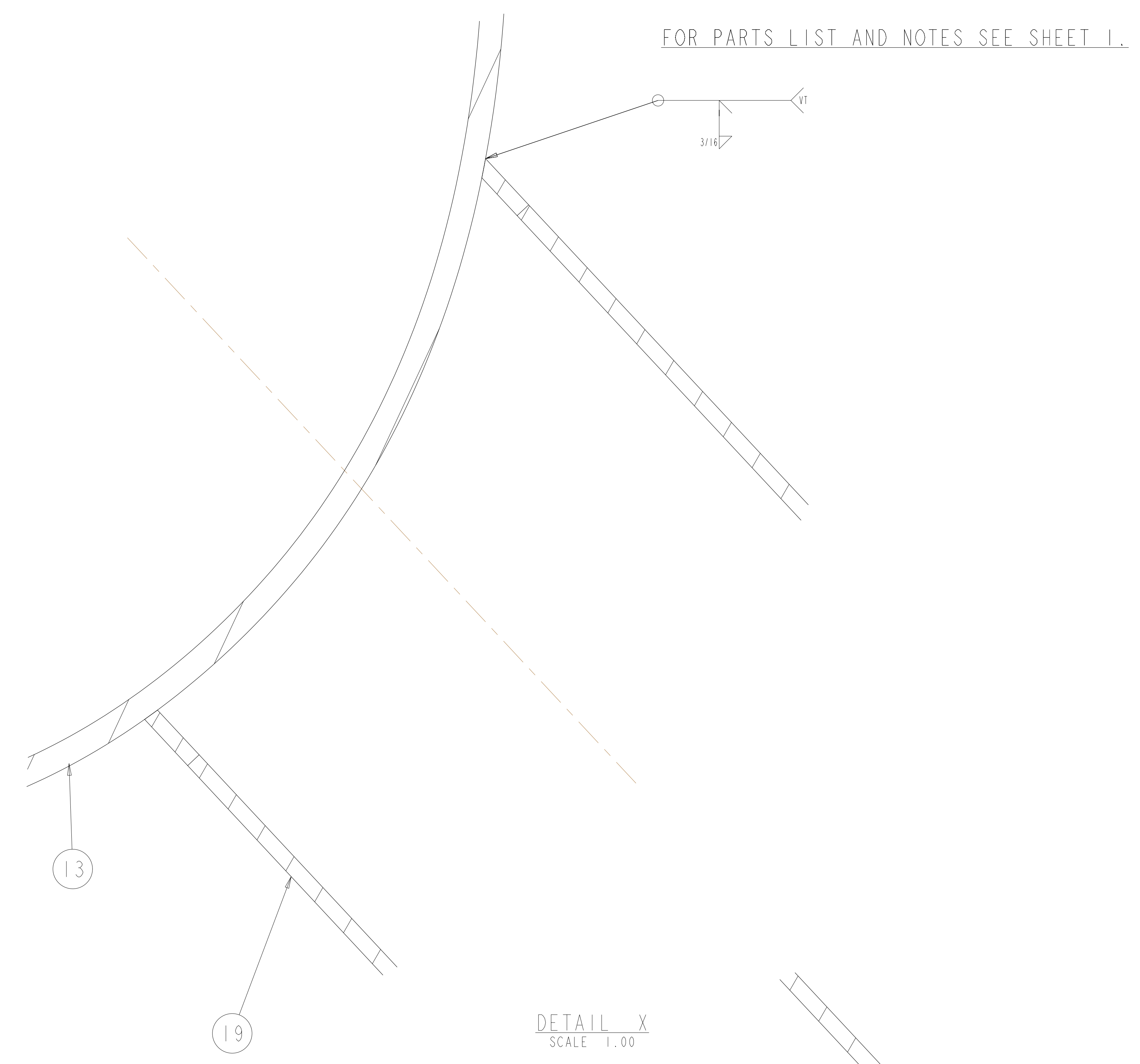

TYPICAL PORT 6A AND 6B  
 SECTION PORT06-PORT06

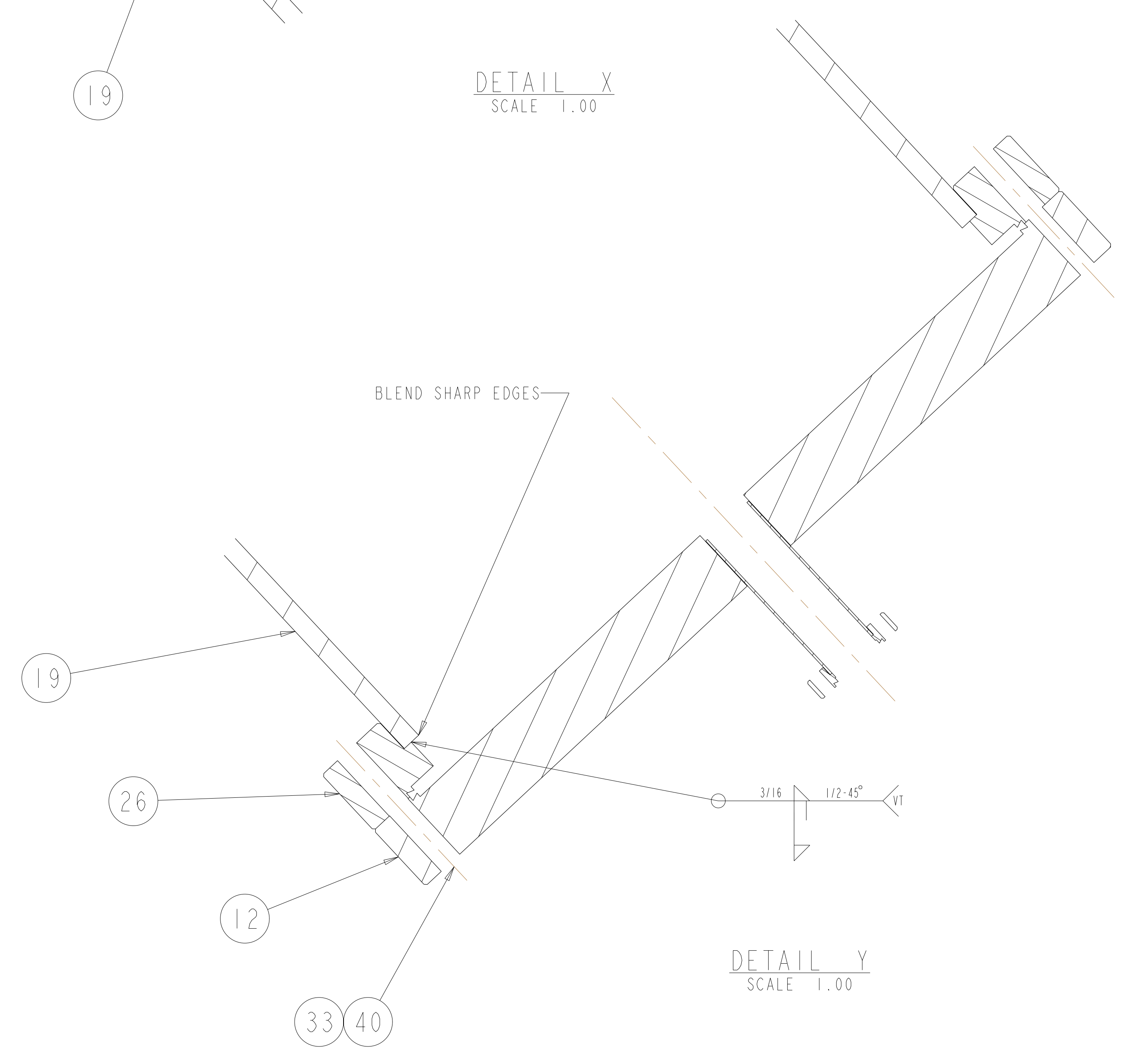

**RELEASED FOR  
 FABRICATION / INSTALLATION**  
 PPPL Drafting:

<b>UT-BATTELLE</b>		Oak Ridge National Laboratory managed for the DEPARTMENT OF ENERGY under U.S. GOVERNMENT contract DE-AC05-00OR22725 UT-BATTELLE, LLC, Oak Ridge, Tennessee					
NATIONAL COMPACT STELLARATOR EXPERIMENT		PROJECT NAME					
VACUUM VESSEL PERIOD INSPECTION AND LEAK CHECK ASSEMBLY		CLASS					
VERSION NO. 5	PLANT X-10	BLDG 5700	FL 3	SHT OF 7	TYPE 19	CLASS A	REV U
RELEASE LEVEL Fabrication		SEI20-004				REV 2	

H  
G  
F  
E  
D  
C  
B  
A

FOR PARTS LIST AND NOTES SEE SHEET 1.

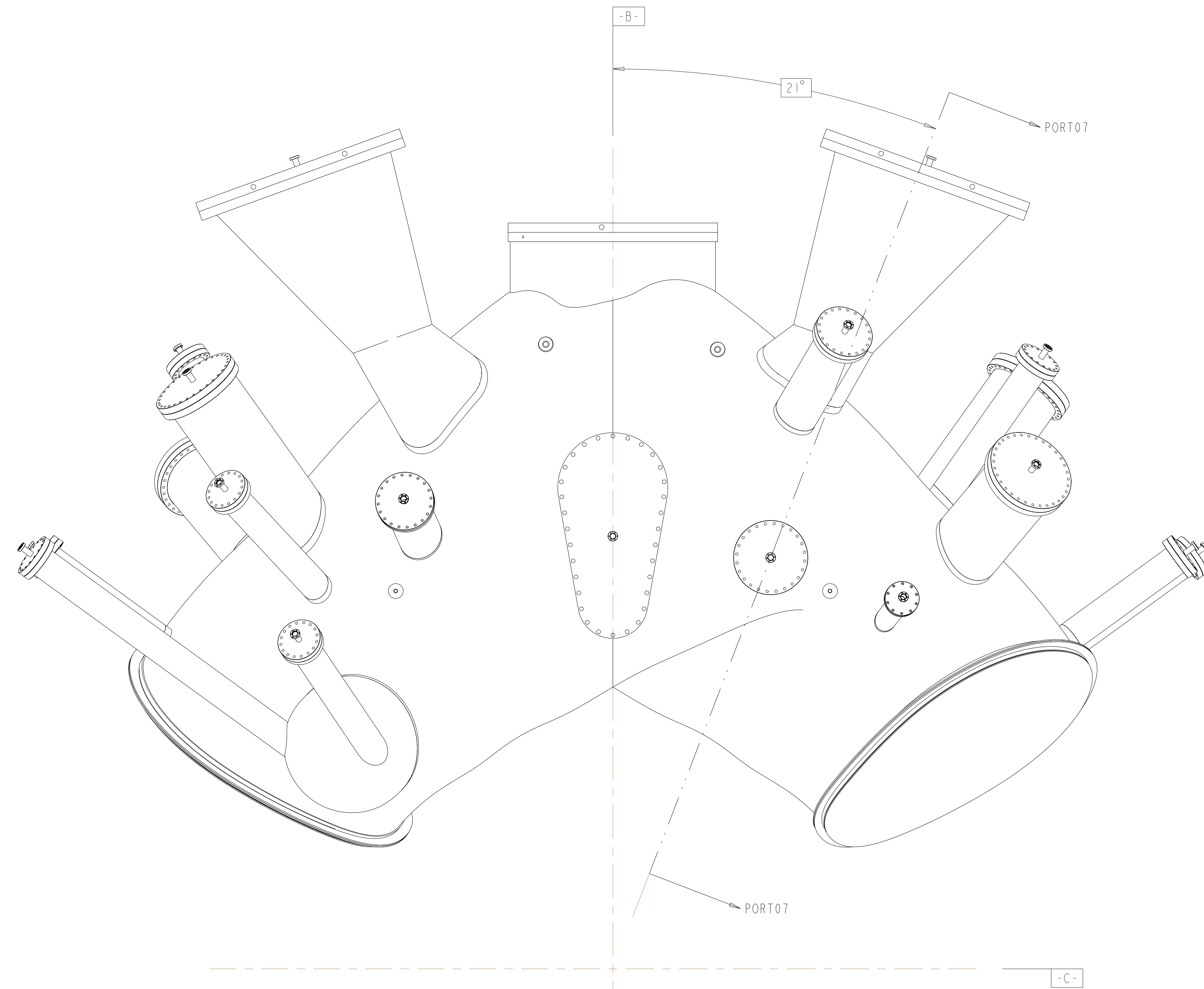

BOTTOM VIEW

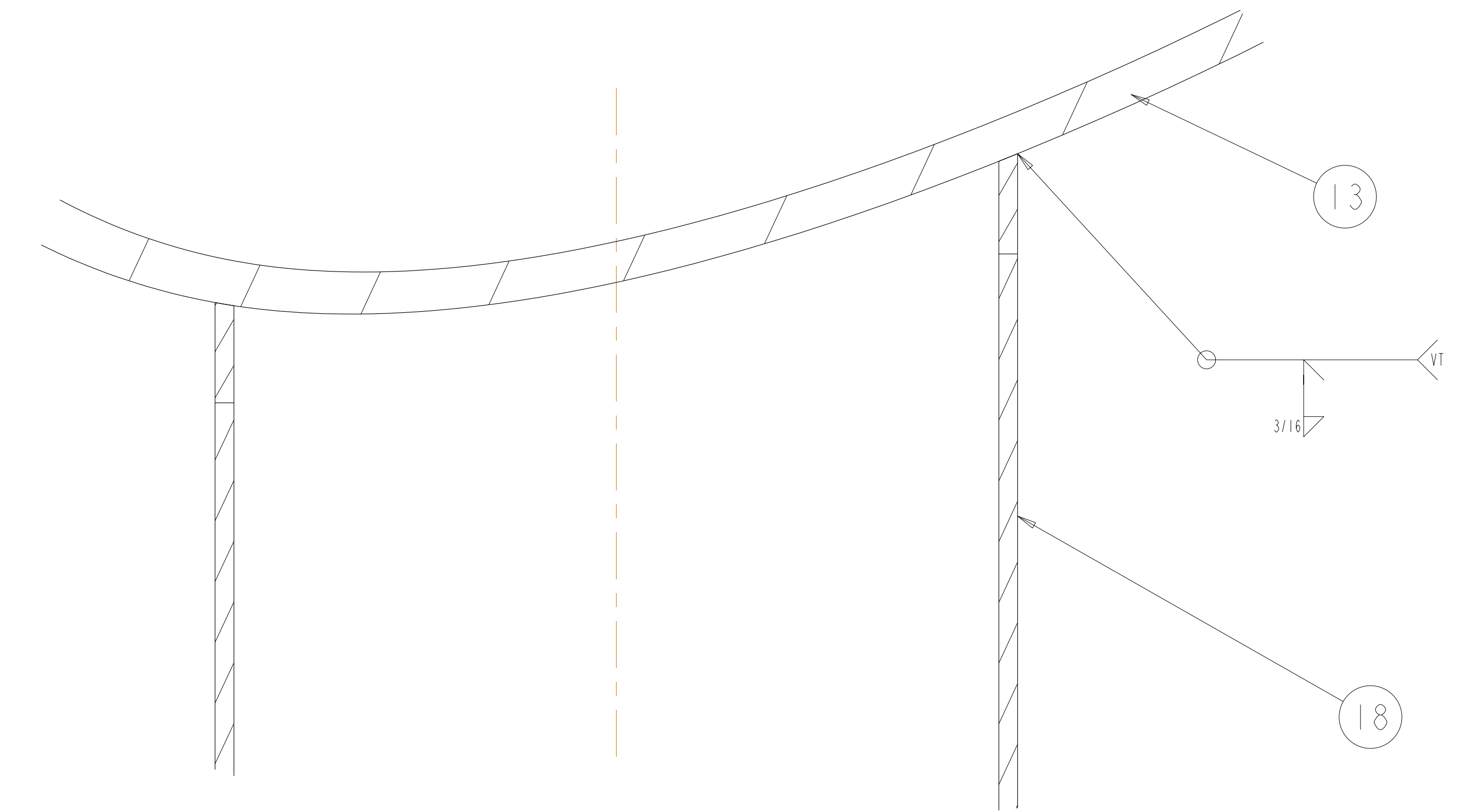

DETAIL X  
SCALE 1.00

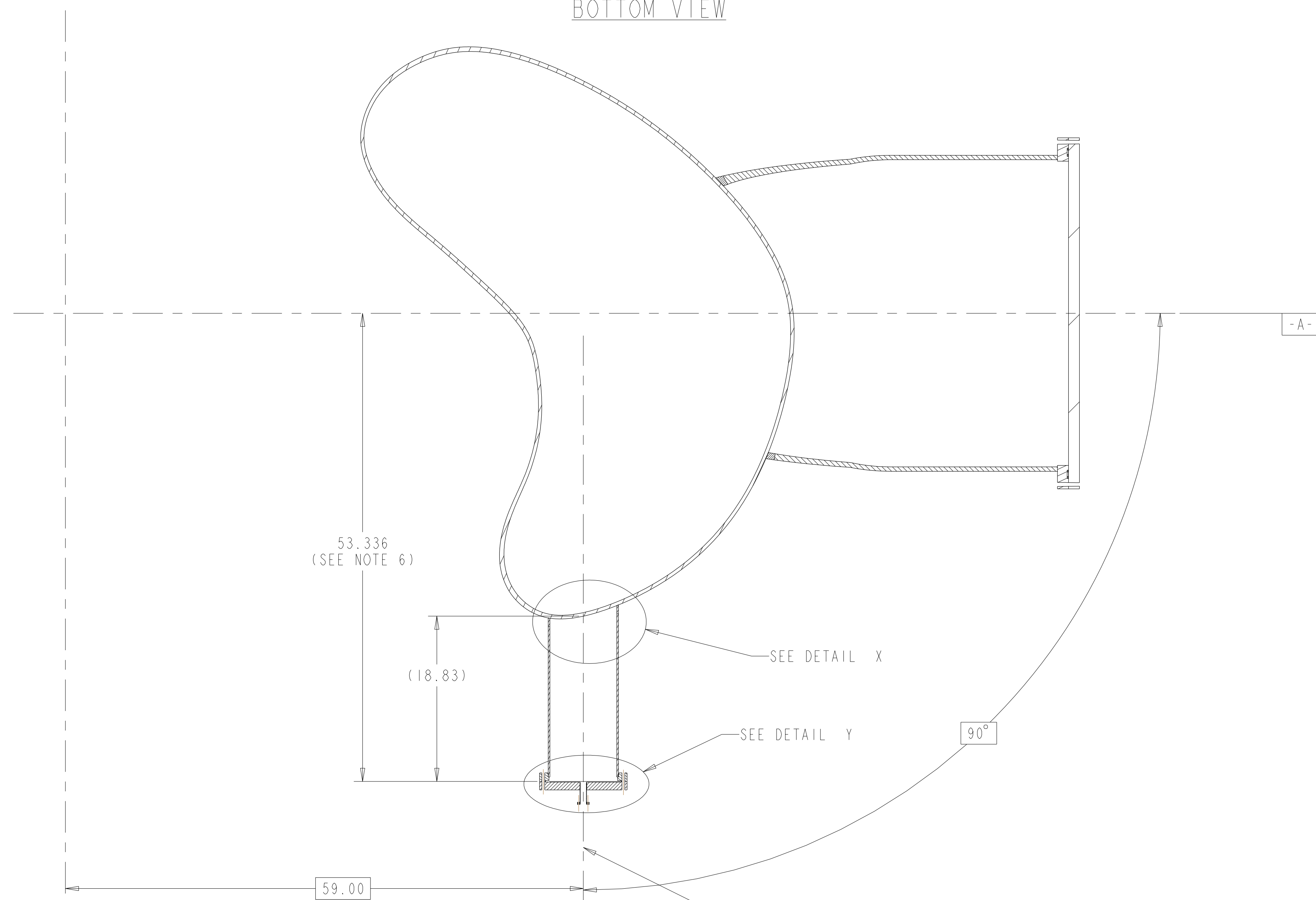

TYPICAL PORT 7A AND 7B  
SECTION PORT07-PORT07

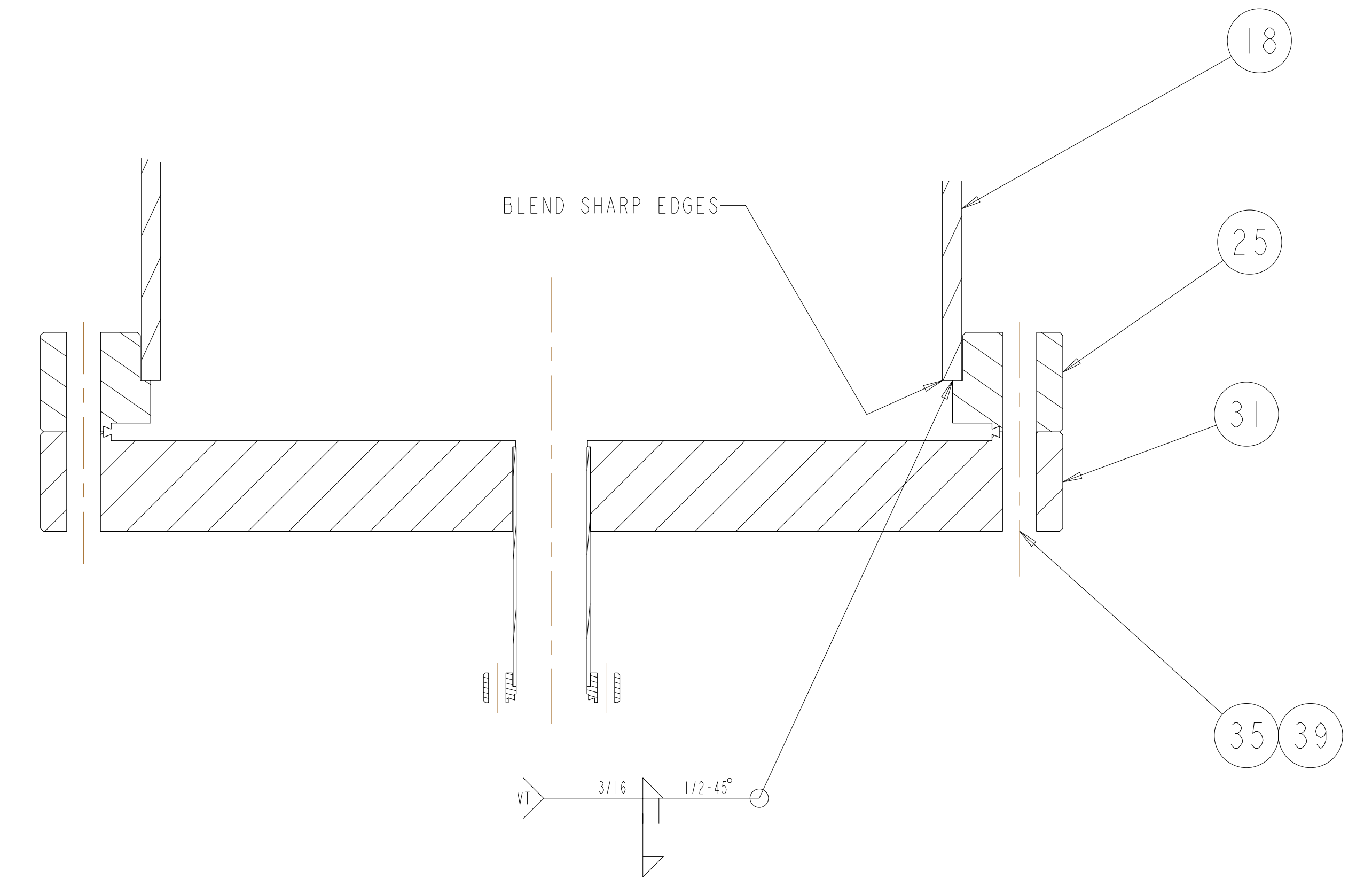

DETAIL Y  
SCALE 1.00

**RELEASED FOR  
FABRICATION / INSTALLATION**  
PPPL Drafting:

UT-BATTELLE		Oak Ridge National Laboratory managed for the DEPARTMENT OF ENERGY under U.S. GOVERNMENT contract DE-AC05-00OR22725 UT-BATTELLE, LLC, Oak Ridge, Tennessee					
NATIONAL COMPACT STELLARATOR EXPERIMENT		PROJECT NAME					
VACUUM VESSEL PERIOD INSPECTION AND LEAK CHECK ASSEMBLY		CLASS					
VERSION NO. 5	PLANT X-10	BLDG 5700	FL 3	SHT OF 8 19	TYPE A	CLASS U	REV 2
RELEASE LEVEL Fabrication	SE120-004						

H  
G  
F  
E  
D  
C  
B  
A

SE120-004



FOR PARTS LIST AND NOTES SEE SHEET 1.

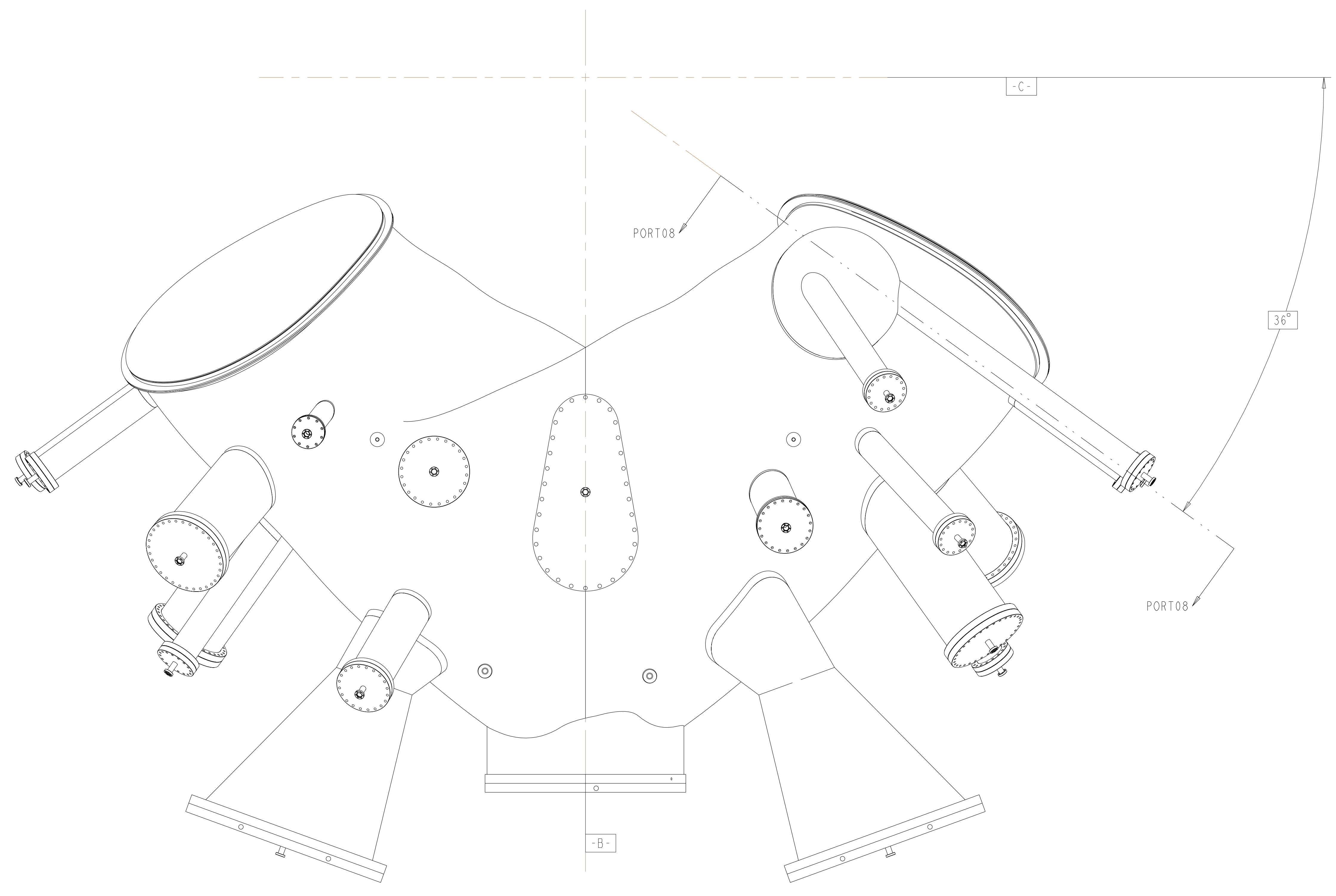

TOP VIEW

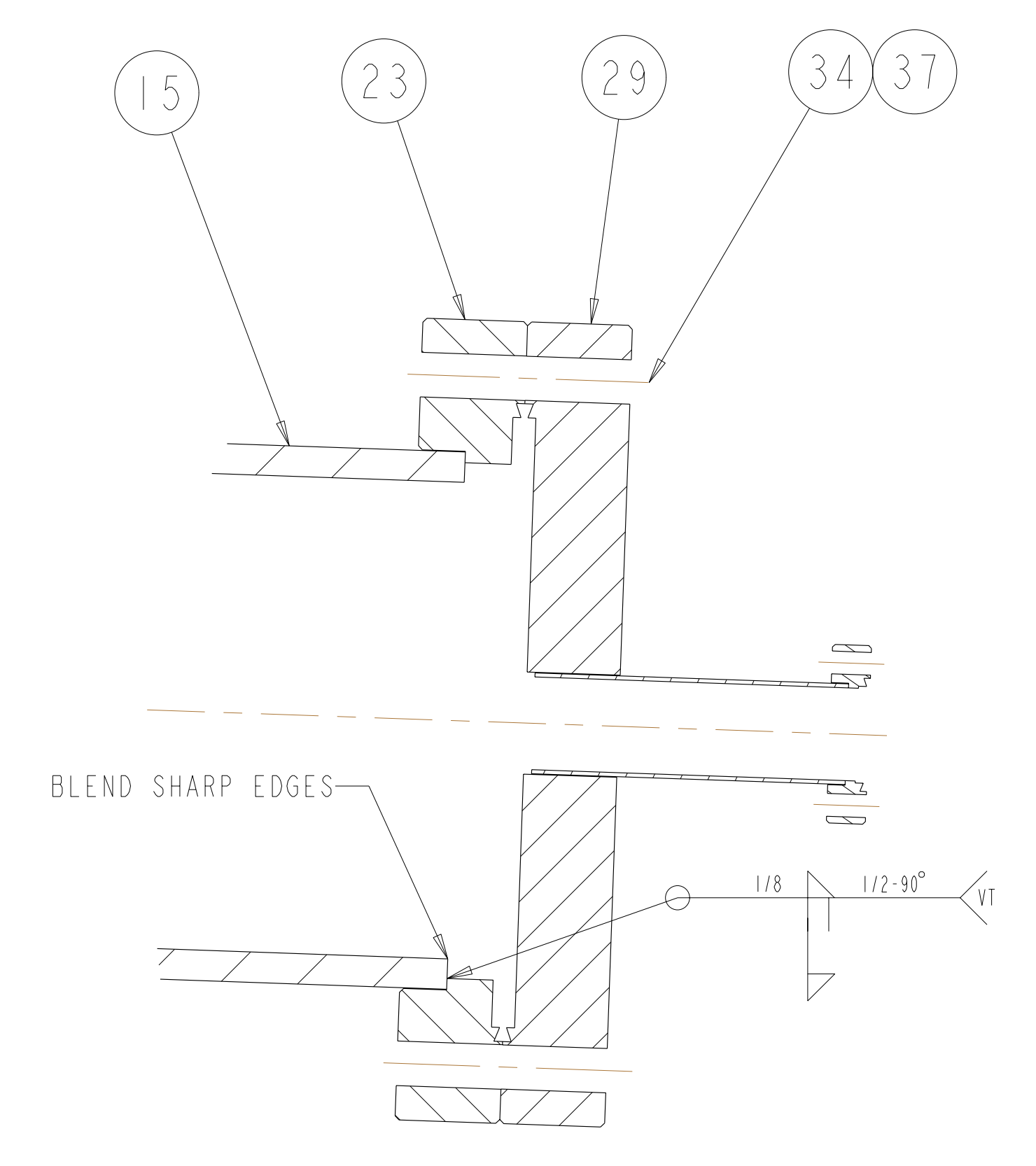

DETAIL Y  
 SCALE 1.00

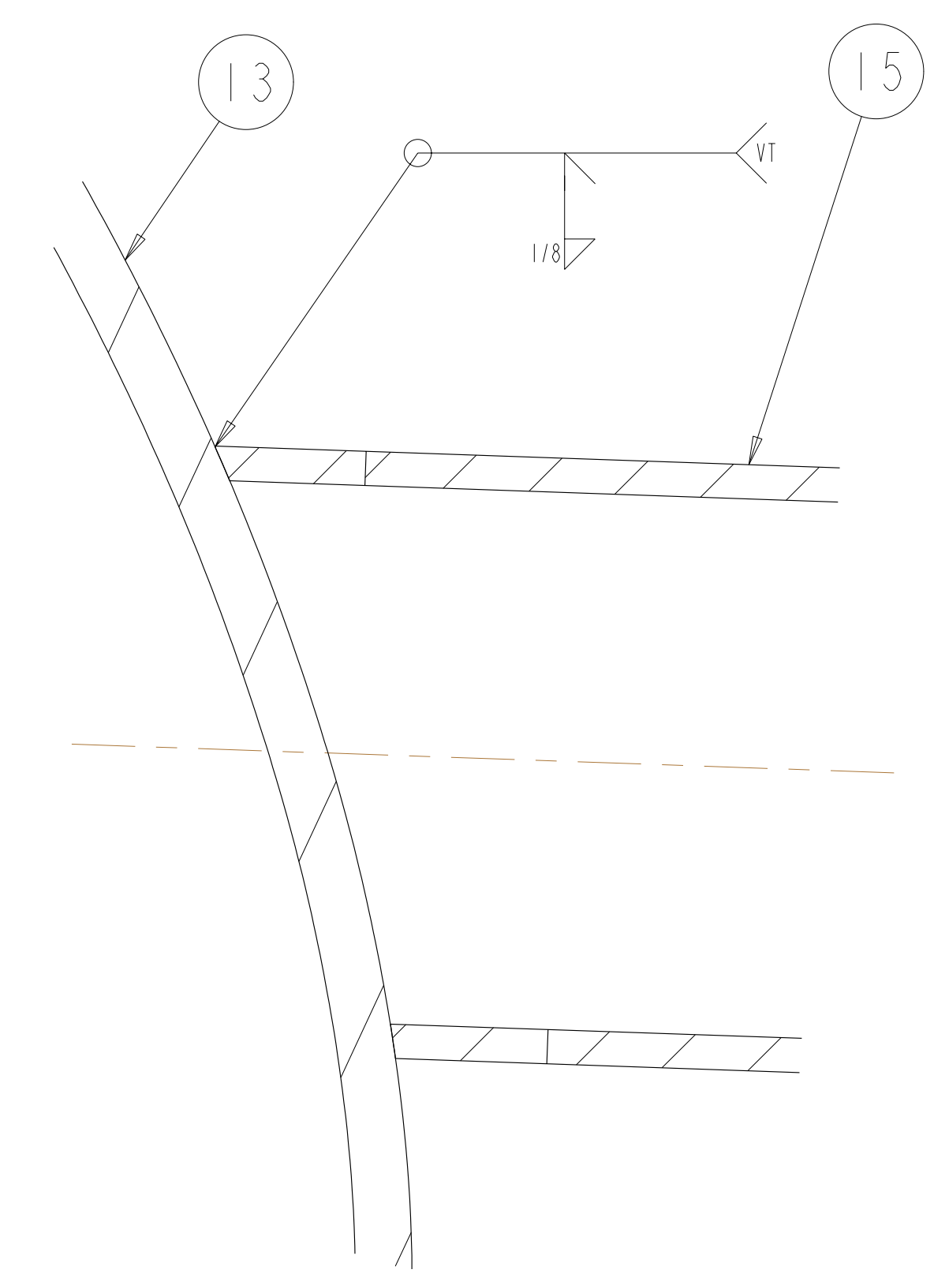

DETAIL X  
 SCALE 1.00

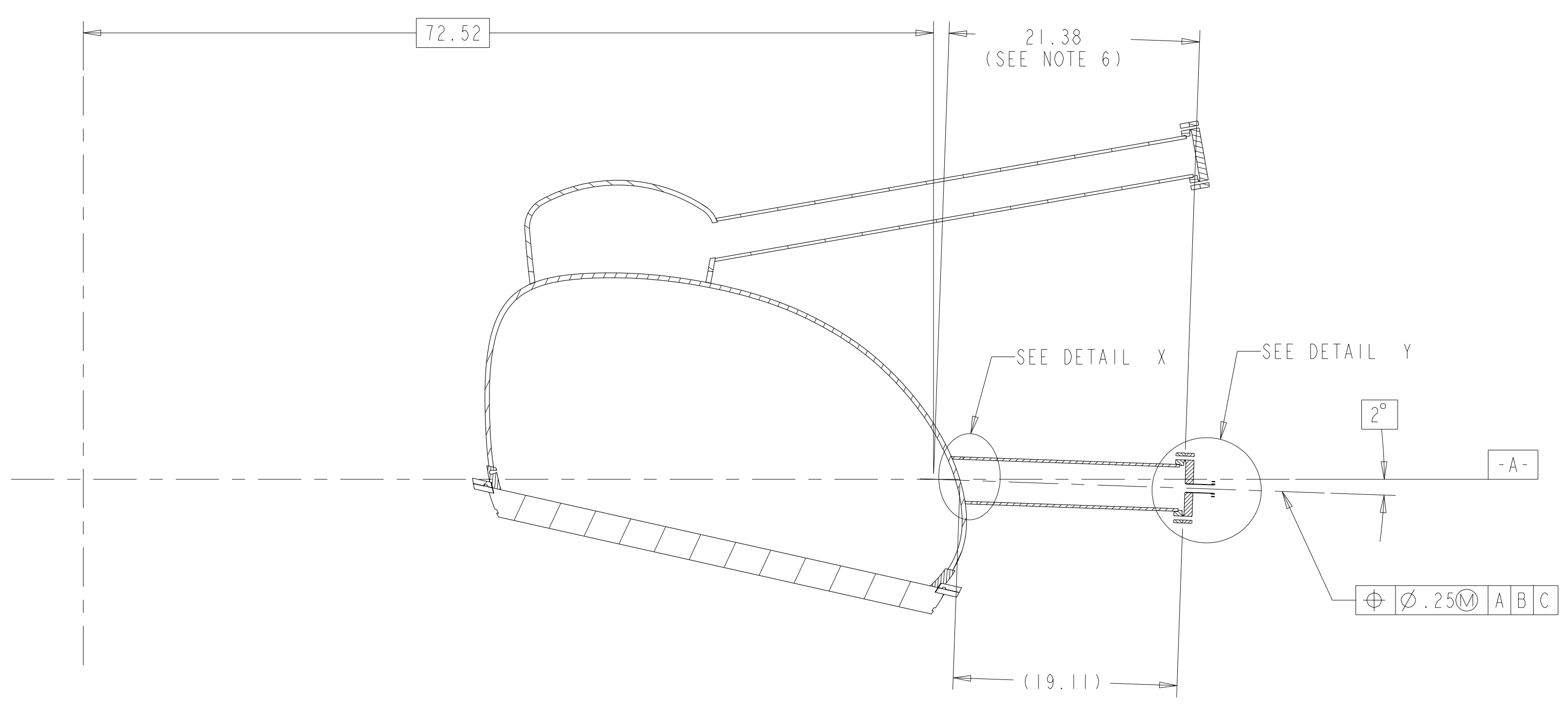

TYPICAL PORT 8A AND 8B  
 SECTION PORT08-PORT08

**RELEASED FOR  
 FABRICATION / INSTALLATION**  
 PPPL Drafting:

Oak Ridge National Laboratory managed for the DEPARTMENT OF ENERGY under U.S. GOVERNMENT contract DE-AC05-00OR22725 UT-BATTELLE, LLC., Oak Ridge, Tennessee PROJECT NAME						
NATIONAL COMPACT STELLERATOR EXPERIMENT VACUUM VESSEL PERIOD INSPECTION AND LEAK CHECK ASSEMBLY						
VERSION NO.	PLANT	BLDG	FL	SHT OF	TYPE	CLASS
5	X-10	5700	3	9 19	A	U
RELEASE LEVEL	SE120-004					REV
Fabrication						2

H  
G  
F  
E  
D  
C  
B  
A

SE120-004

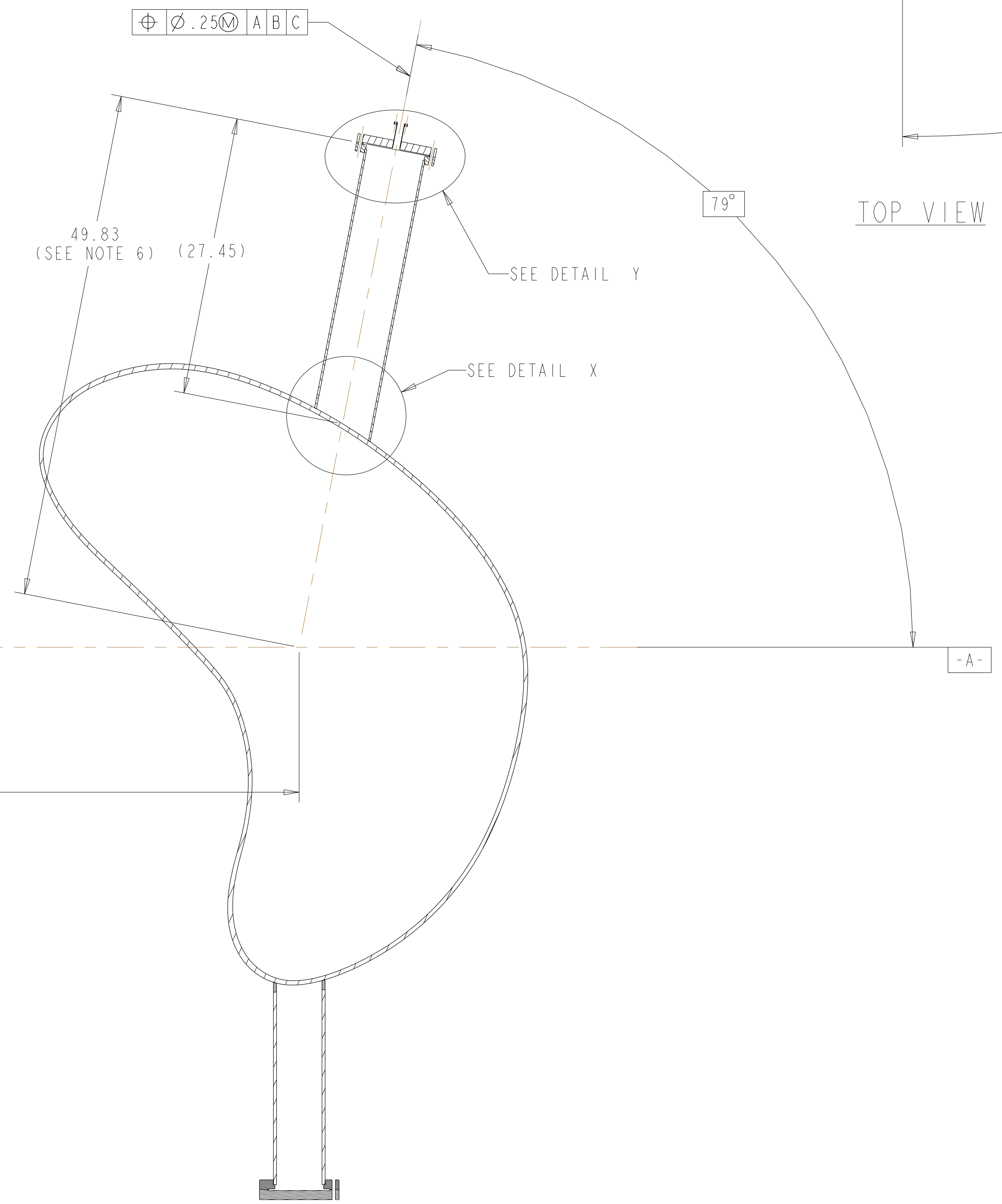
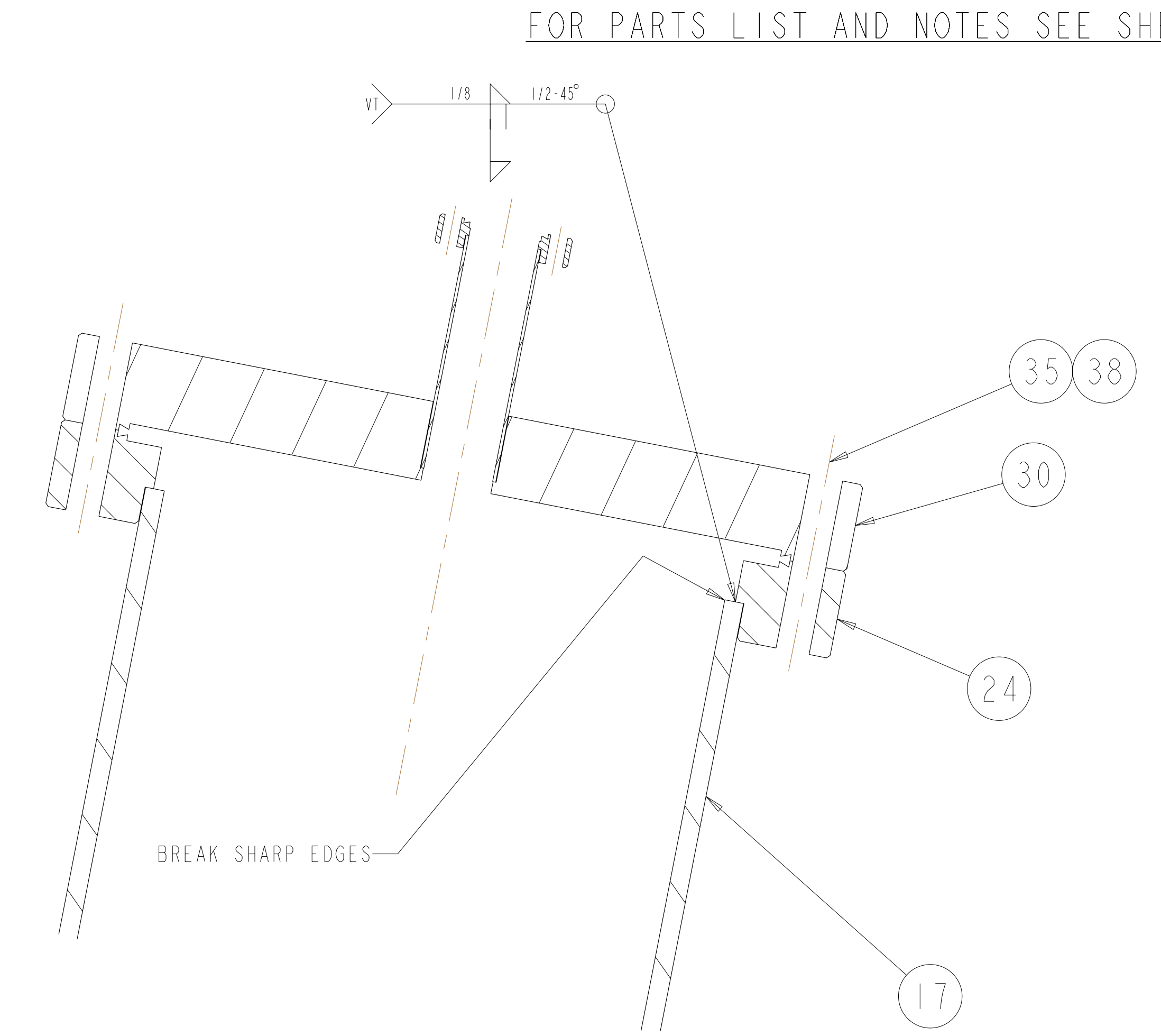
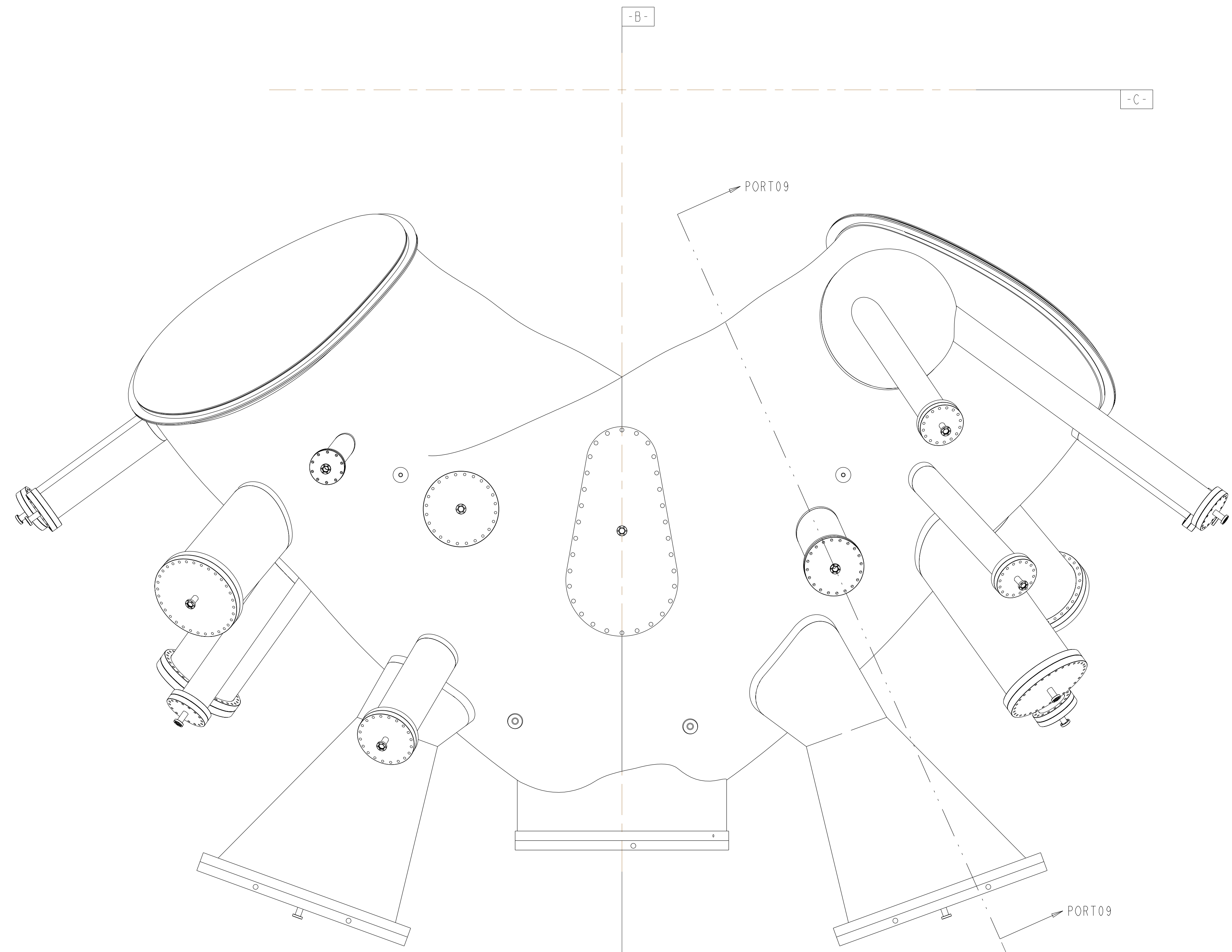

TYPICAL PORT 9A AND 9B  
 SECTION PORT09-PORT09

**RELEASED FOR  
 FABRICATION / INSTALLATION**  
 PPPL Drafting:

<b>UT-BATTELLE</b>		Oak Ridge National Laboratory managed for the DEPARTMENT OF ENERGY under U.S. GOVERNMENT contract DE-AC05-00OR22725 UT-BATTELLE, LLC, Oak Ridge, Tennessee					
PROJECT NAME							
NATIONAL COMPACT STELLARATOR EXPERIMENT							
VACUUM VESSEL							
PERIOD INSPECTION AND LEAK CHECK							
ASSEMBLY							
VERSION NO.	PLANT	BLDG	FL	SHT OF	TYPE	CLASS	
5	X-10	5700	3	10	19	A	U
RELEASE LEVEL		SE120-004					REV
Fabrication							2

H  
G  
F  
E  
D  
C  
B  
A

FOR PARTS LIST AND NOTES SEE SHEET 1.

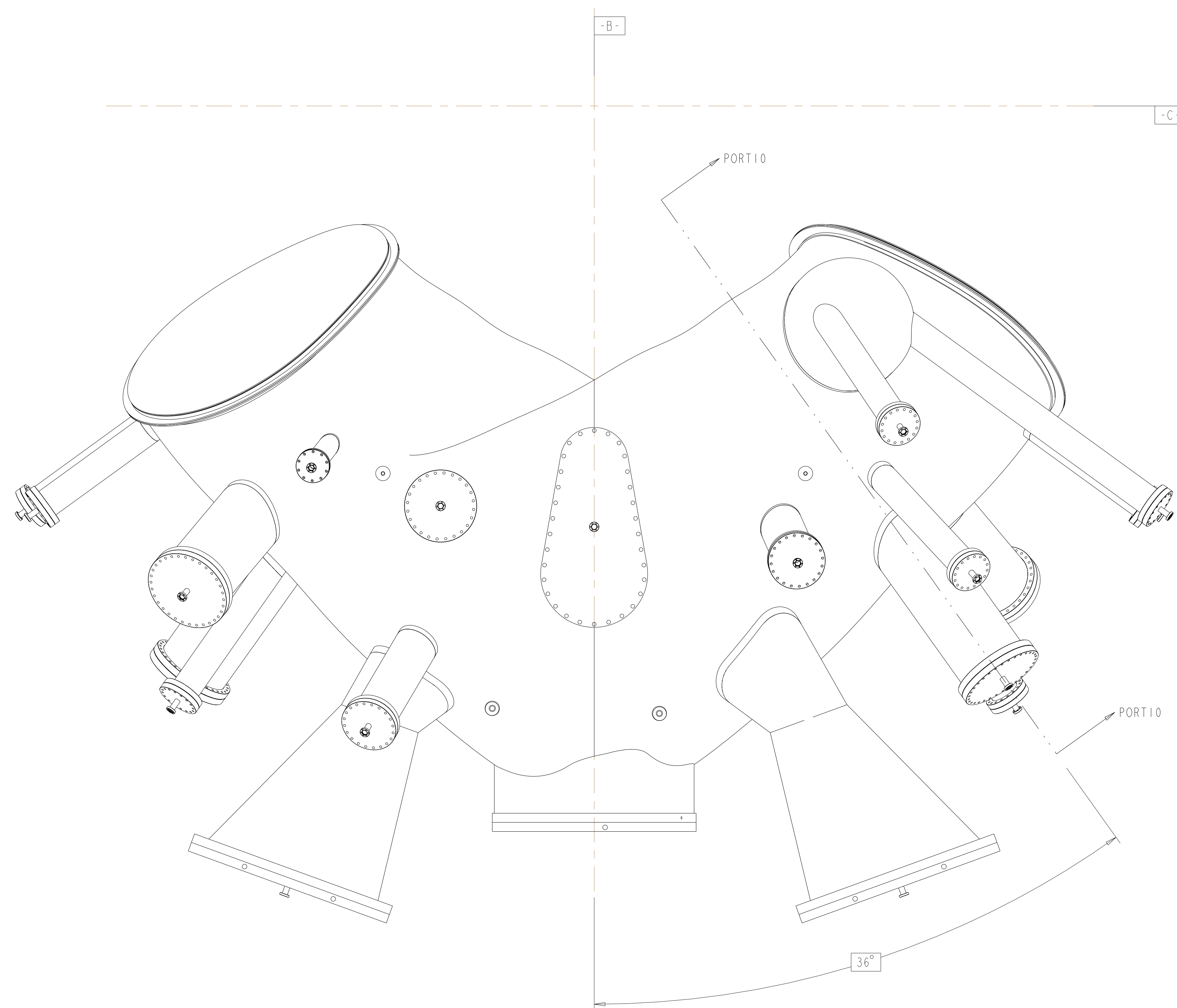

TOP VIEW

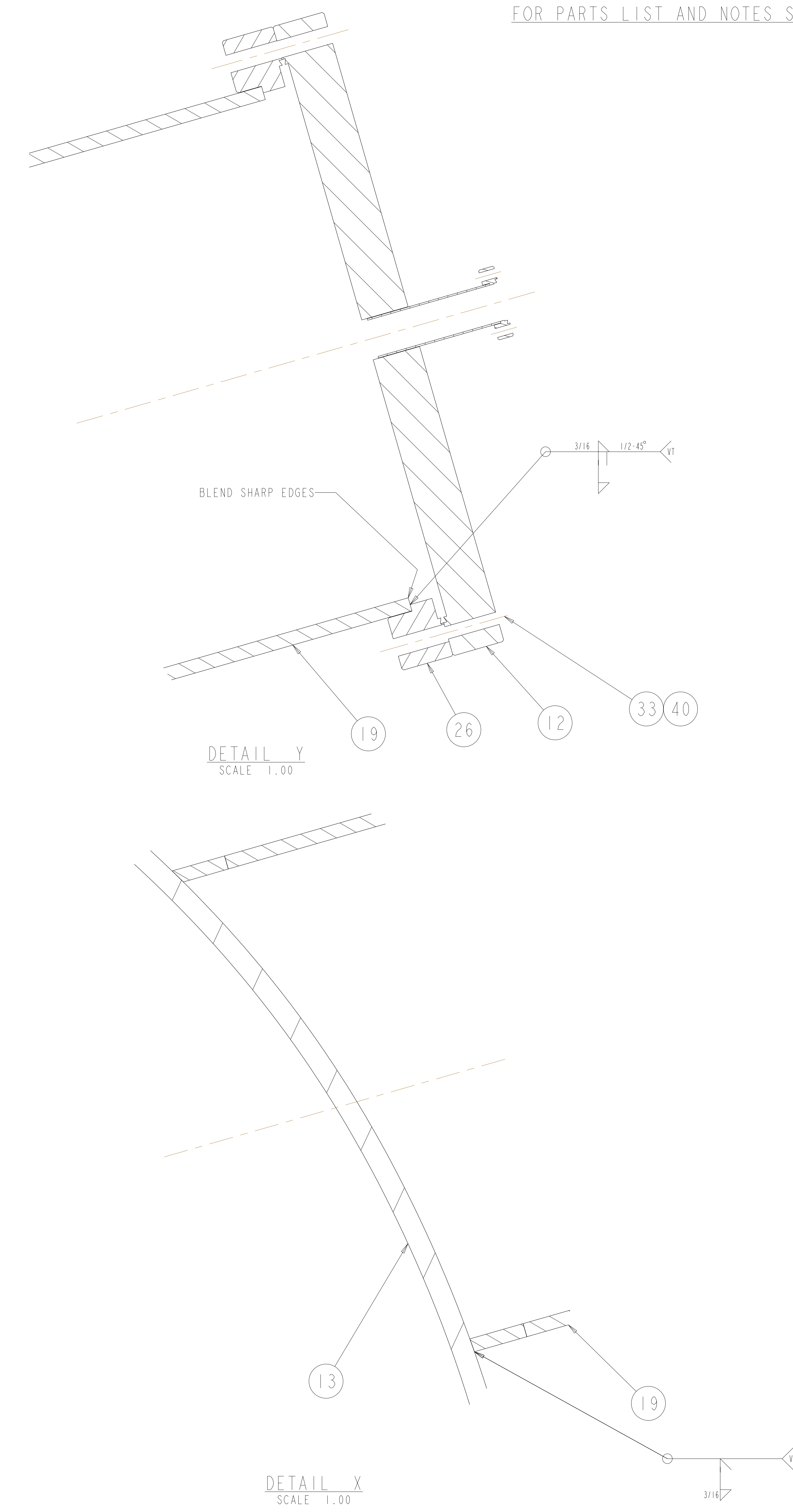

DETAIL Y  
SCALE 1.00

DETAIL X  
SCALE 1.00

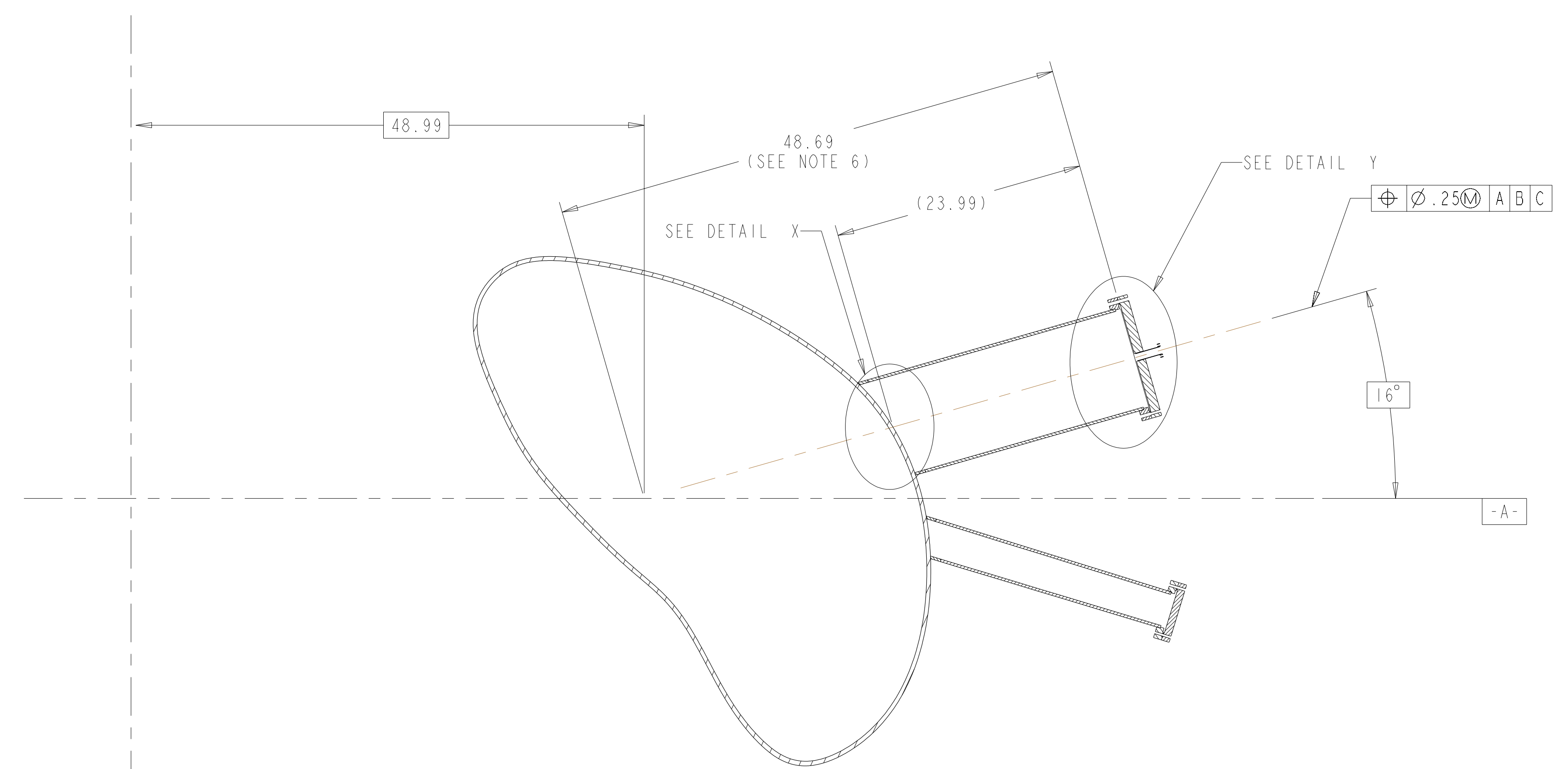

TYPICAL PORT 10A AND 10B  
SECTION PORT10-PORT10

**RELEASED FOR  
FABRICATION / INSTALLATION**  
PPPL Drafting:

<b>UT-BATTELLE</b>		Oak Ridge National Laboratory managed for the DEPARTMENT OF ENERGY under U.S. GOVERNMENT contract DE-AC05-00OR22725 UT-BATTELLE, LLC, Oak Ridge, Tennessee					
		PROJECT NAME					
		NATIONAL COMPACT STELLARATOR EXPERIMENT					
		VACUUM VESSEL					
		PERIOD INSPECTION AND LEAK CHECK					
		ASSEMBLY					
VERSION NO.	PLANT	BLDG	FL	SHT OF	TYPE	CLASS	
5	X-10	5700	3	11 19	A	U	
RELEASE LEVEL	Fabrication		SE120-004				REV 2

H  
G  
F  
E  
D  
C  
B  
A

FOR PARTS LIST AND NOTES SEE SHEET 1.

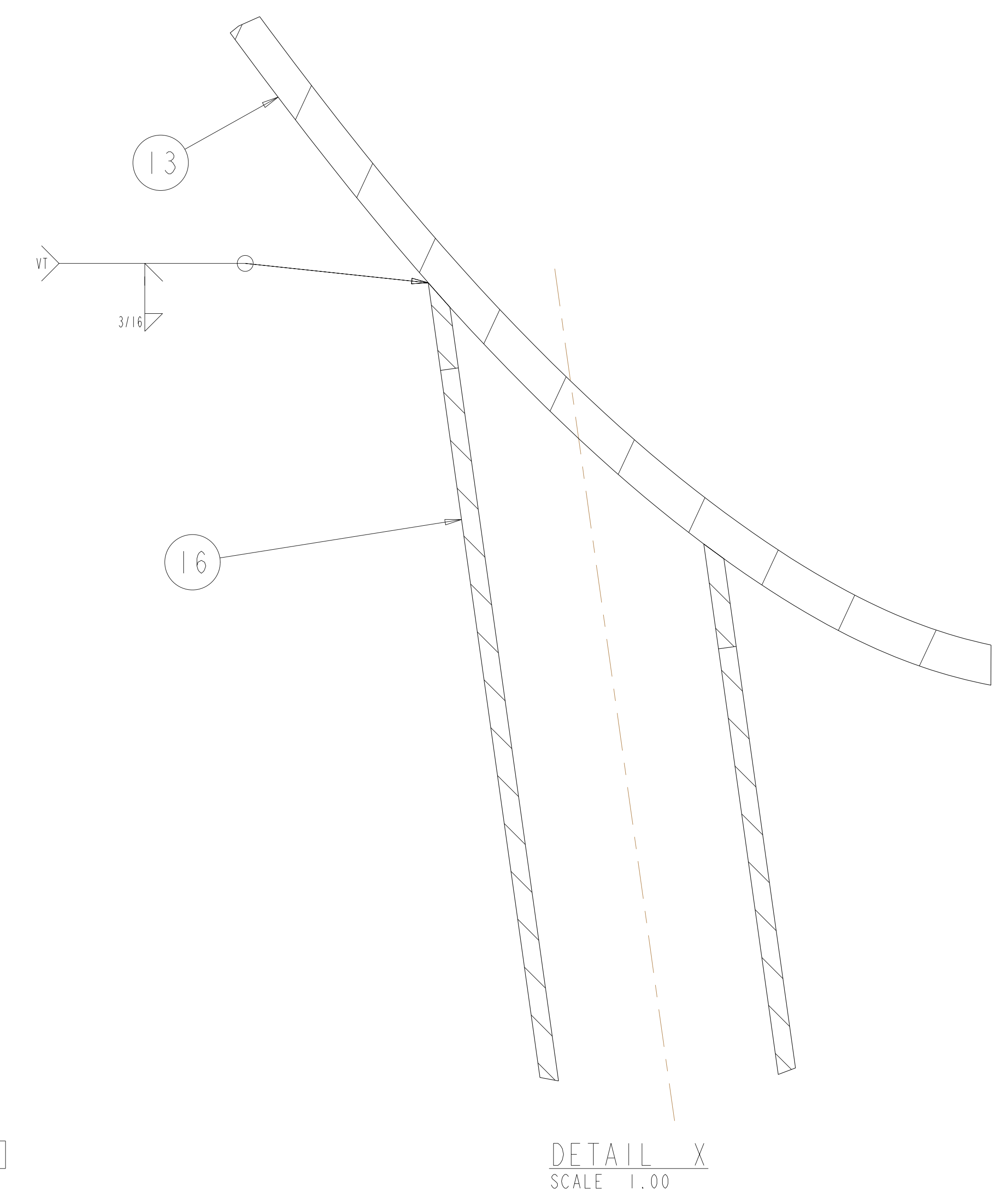
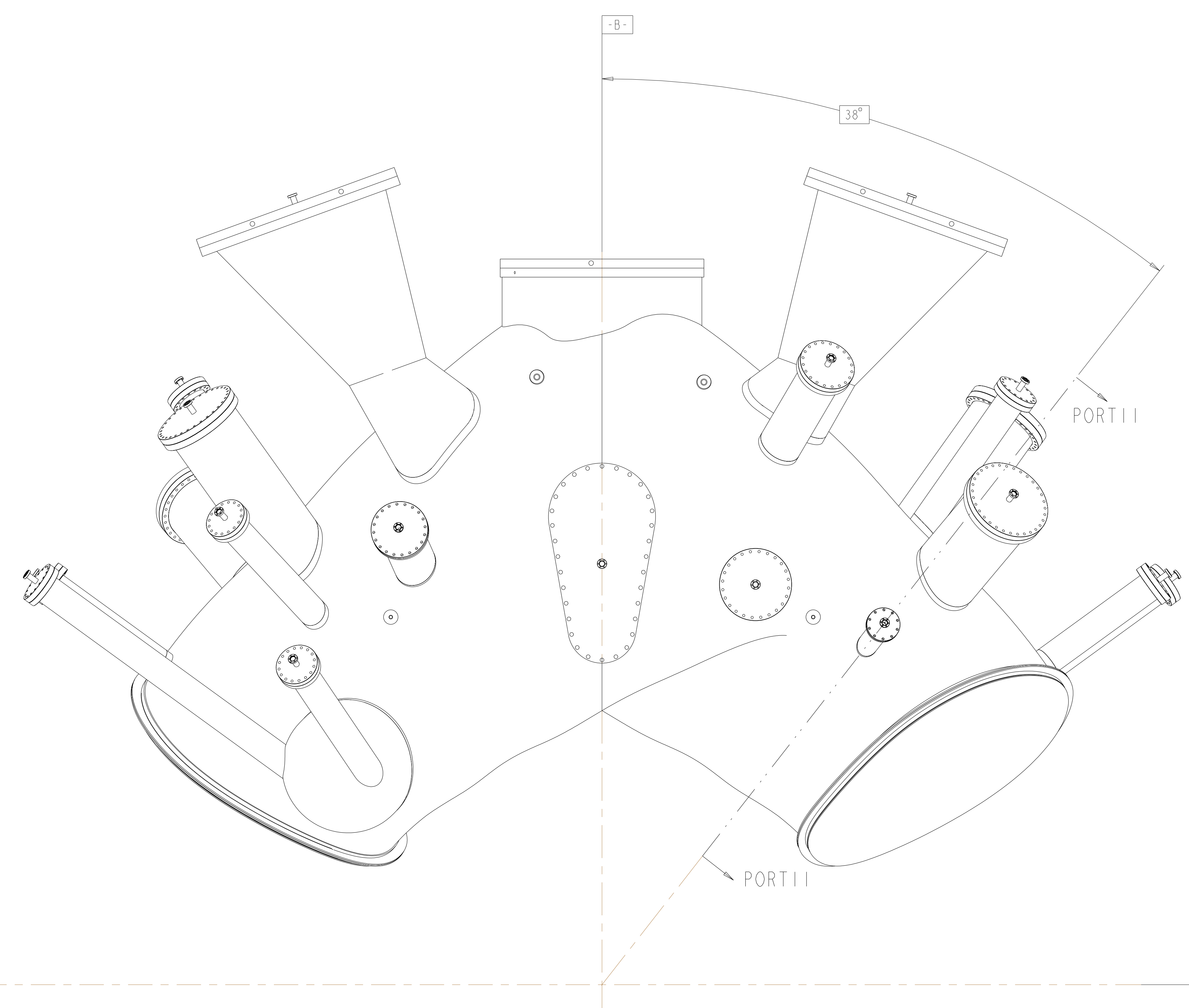

BOTTOM VIEW

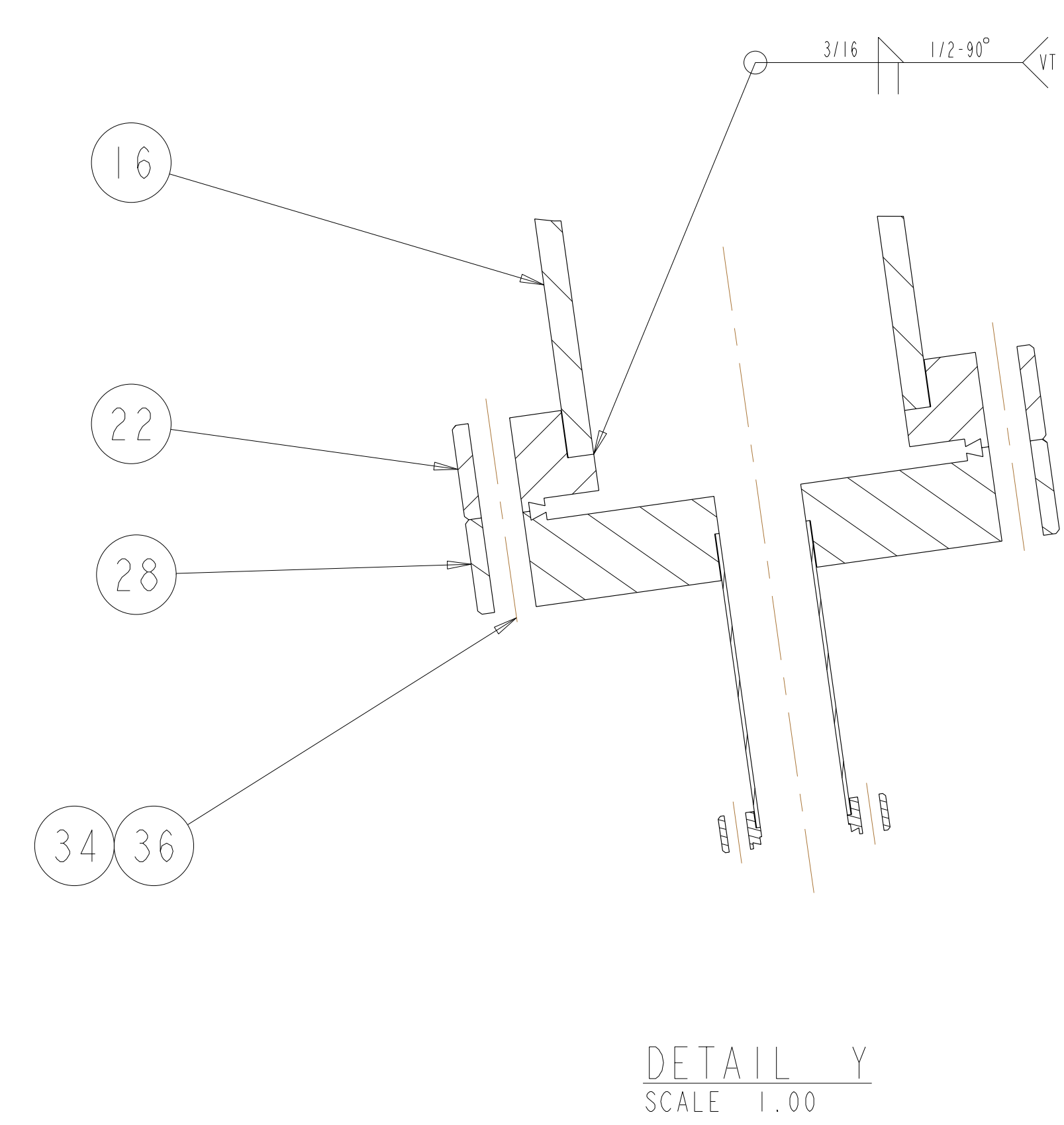
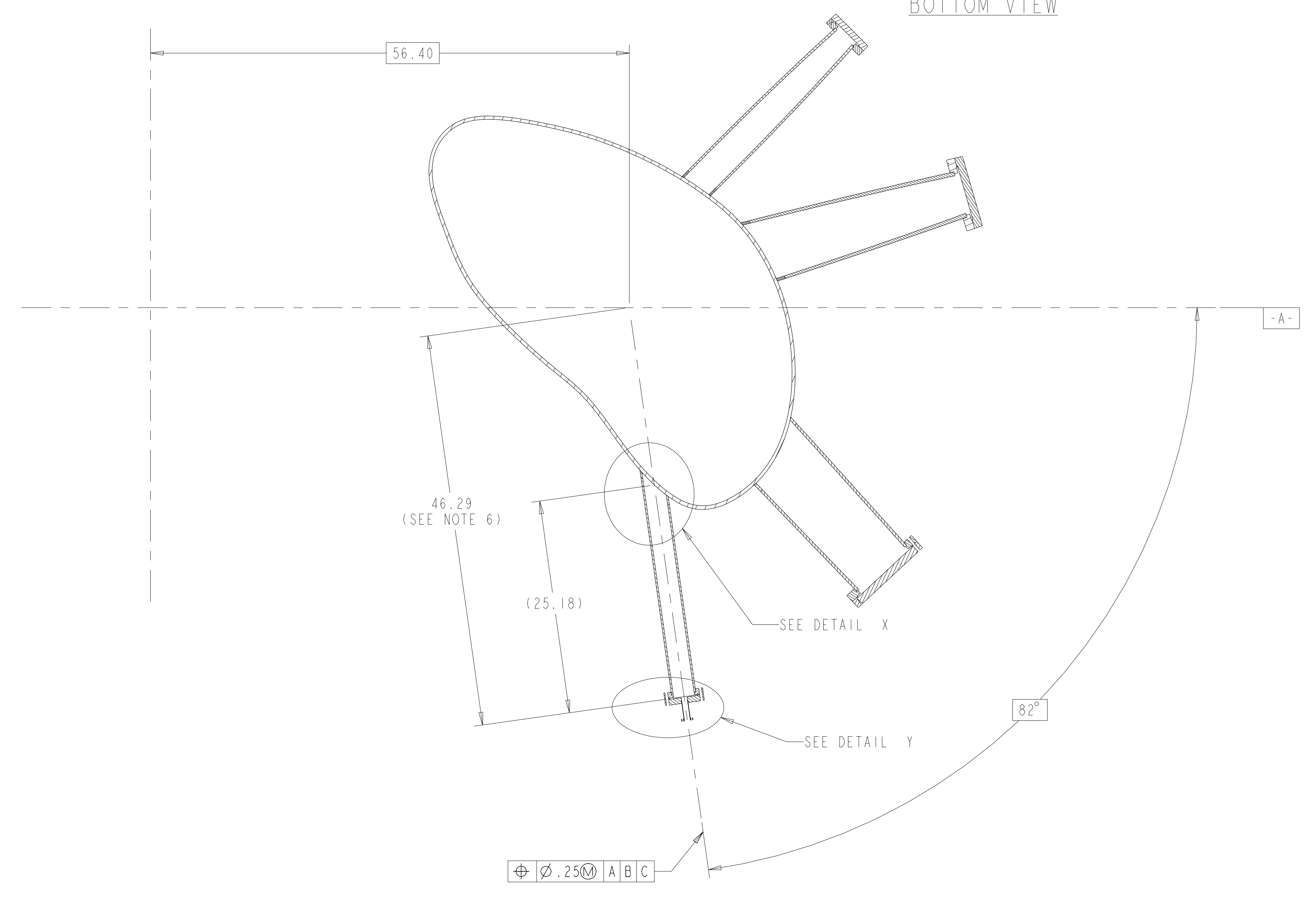

TYPICAL PORT IIA AND IIB SECTION PORT III-PORT III

**RELEASED FOR FABRICATION / INSTALLATION**  
 PPPL Drafting:

UT-BATTELLE		Oak Ridge National Laboratory managed for the DEPARTMENT OF ENERGY under U.S. GOVERNMENT contract DE-AC05-00OR22725 UT-BATTELLE, LLC, Oak Ridge, Tennessee					
NATIONAL COMPACT STELLARATOR EXPERIMENT							
VACUUM VESSEL PERIOD INSPECTION AND LEAK CHECK ASSEMBLY							
VERSION NO. 5	PLANT X-10	BLDG 5700	FL 3	SHT OF 12 19	TYPE A	CLASS U	
RELEASE LEVEL Fabrication		SE120-004				REV 2	

H  
G  
F  
E  
D  
C  
B  
A

SE120-004

FOR PARTS LIST AND NOTES SEE SHEET 1.

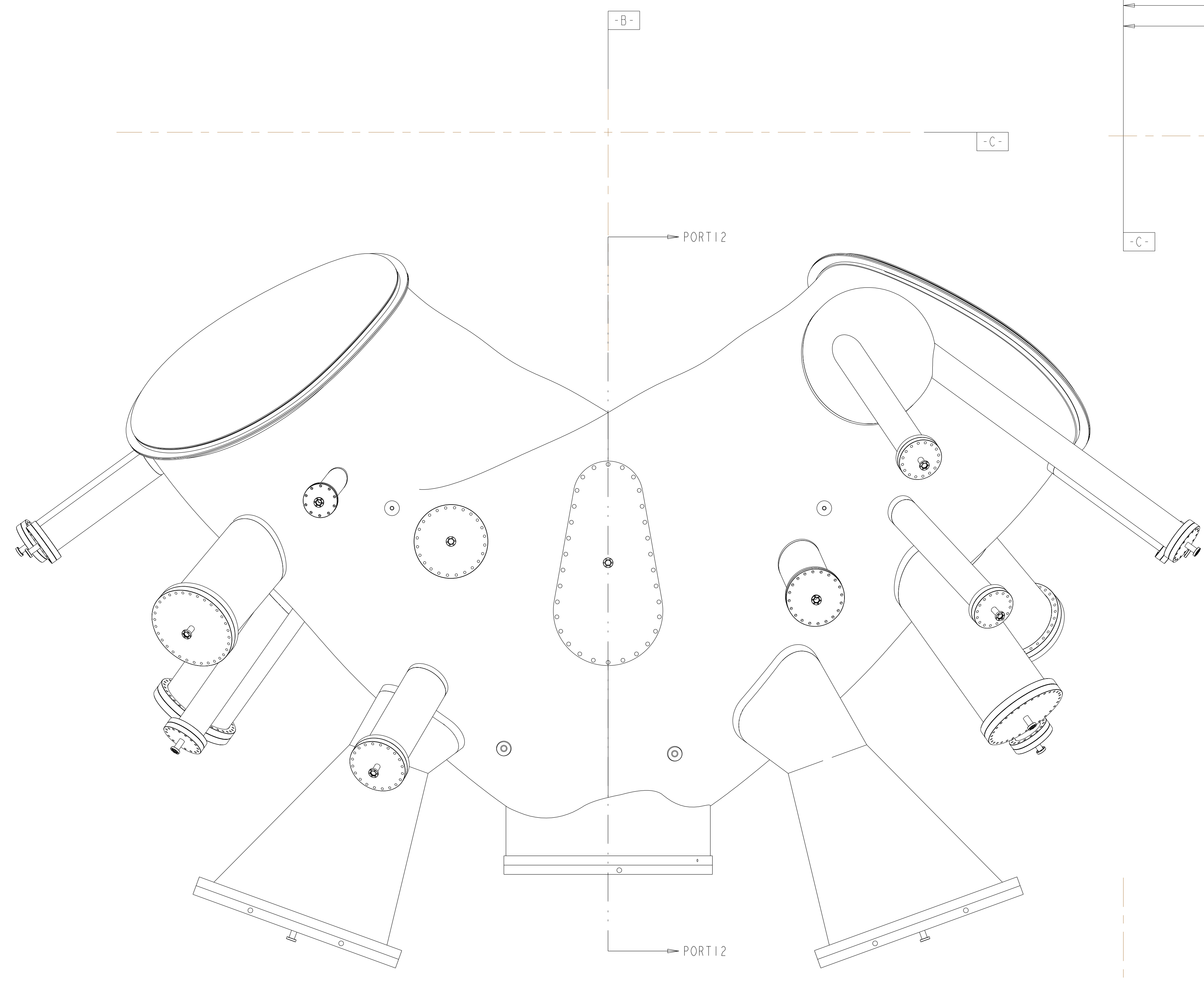

TOP VIEW

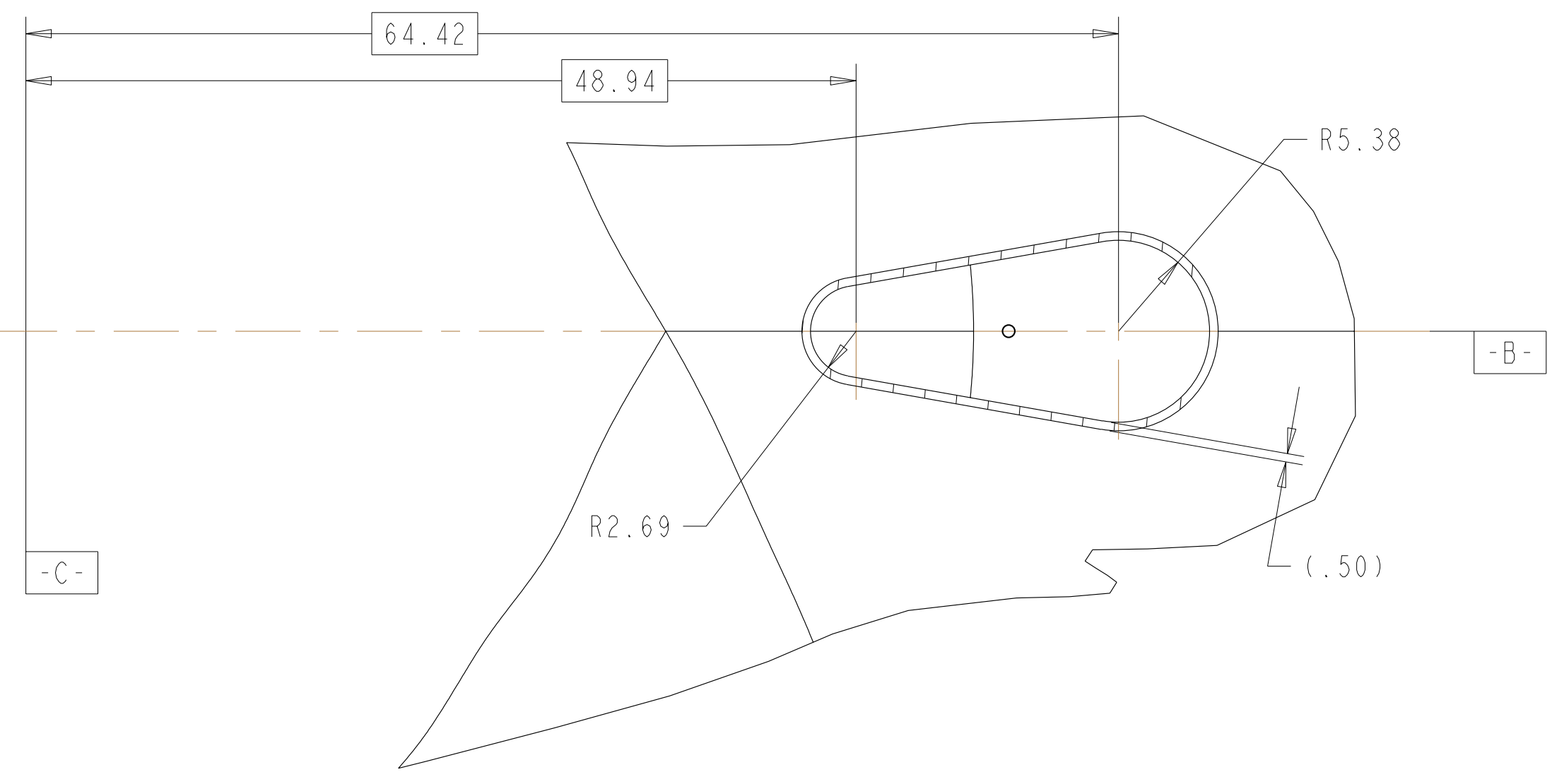

SECTION J-J  
 TYP TOP AND BOTTOM

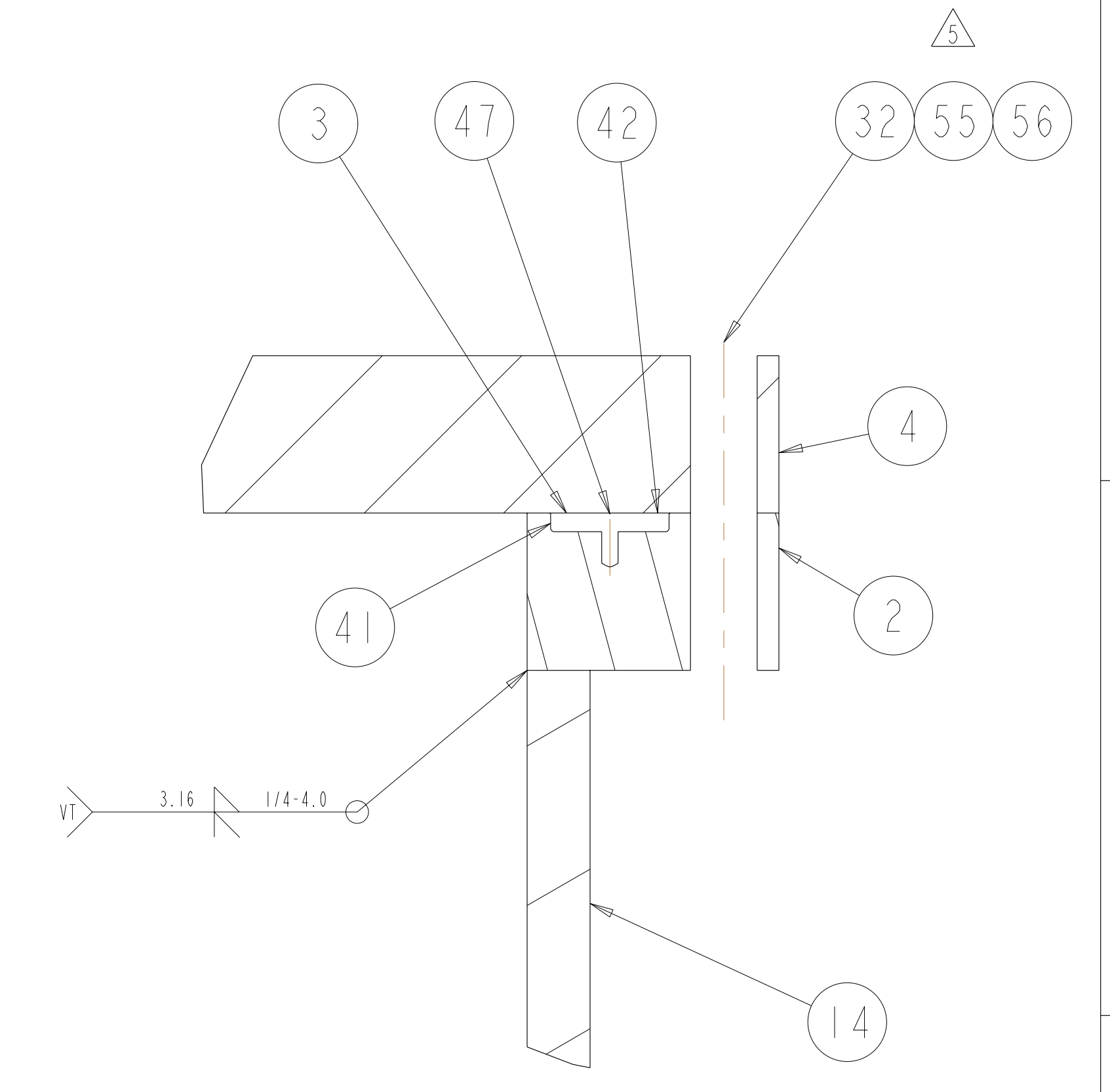

DETAIL Y  
 SCALE 1.00

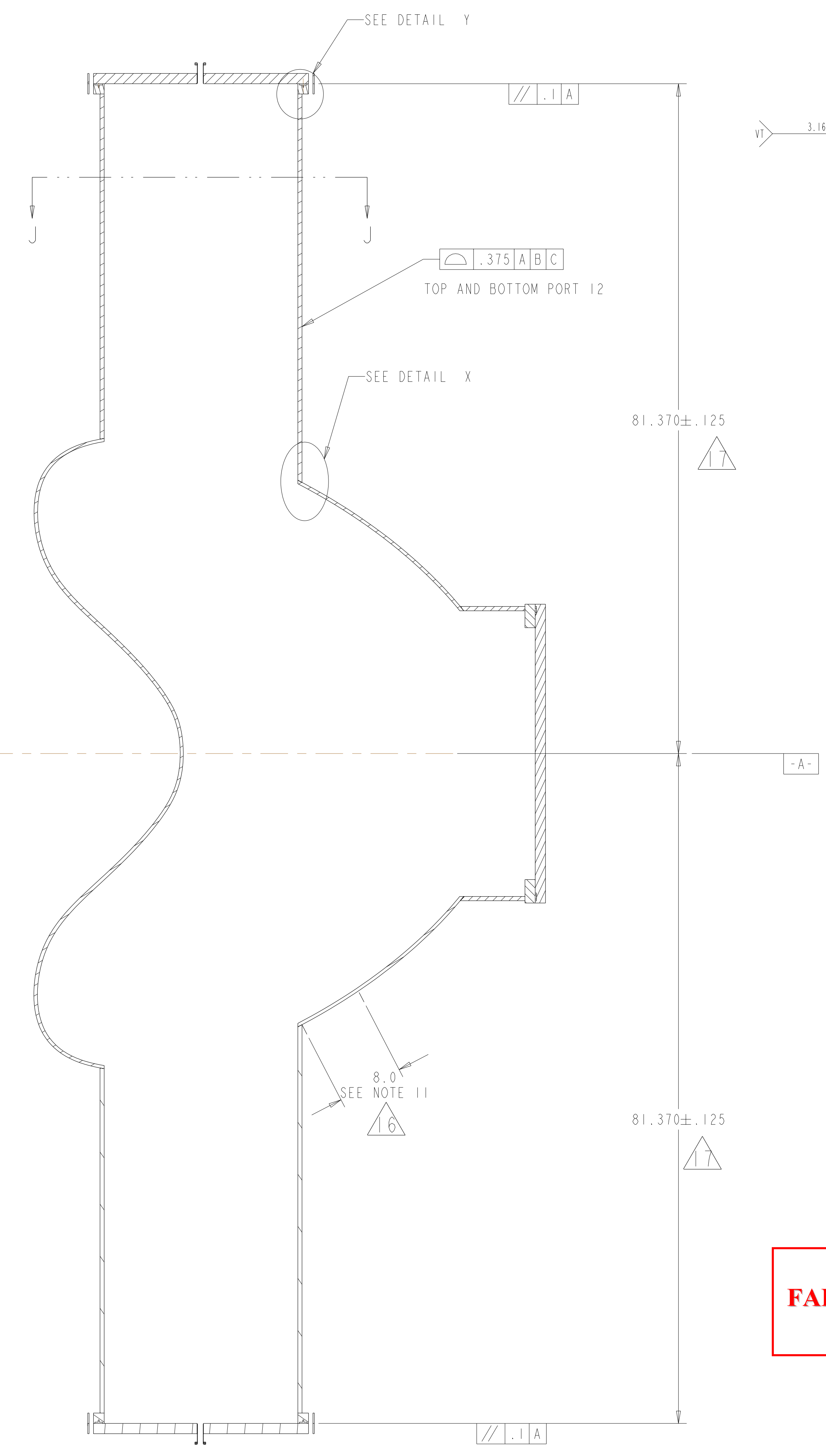

SECTION PORT12-PORT12

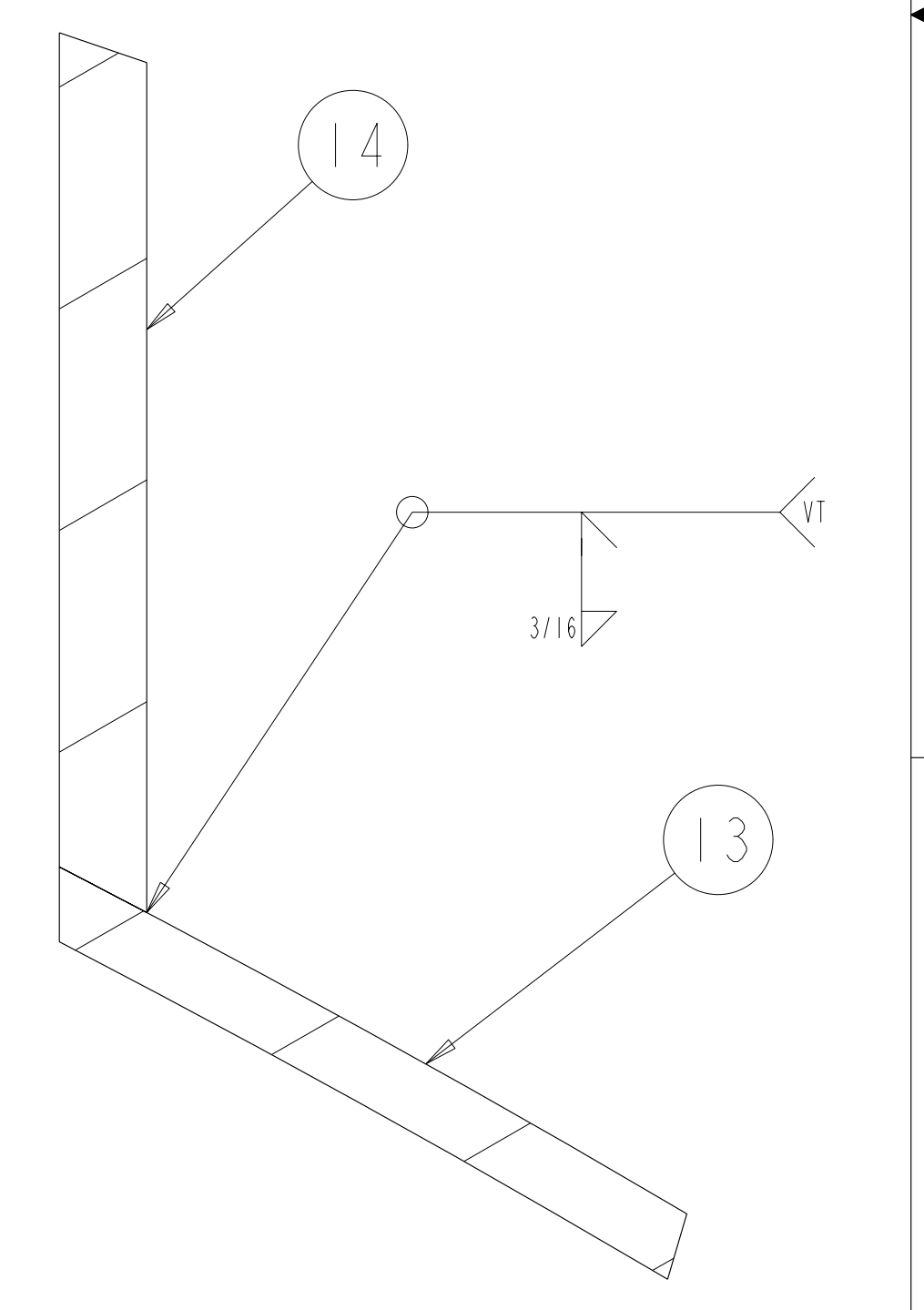

DETAIL X  
 SCALE 1.00

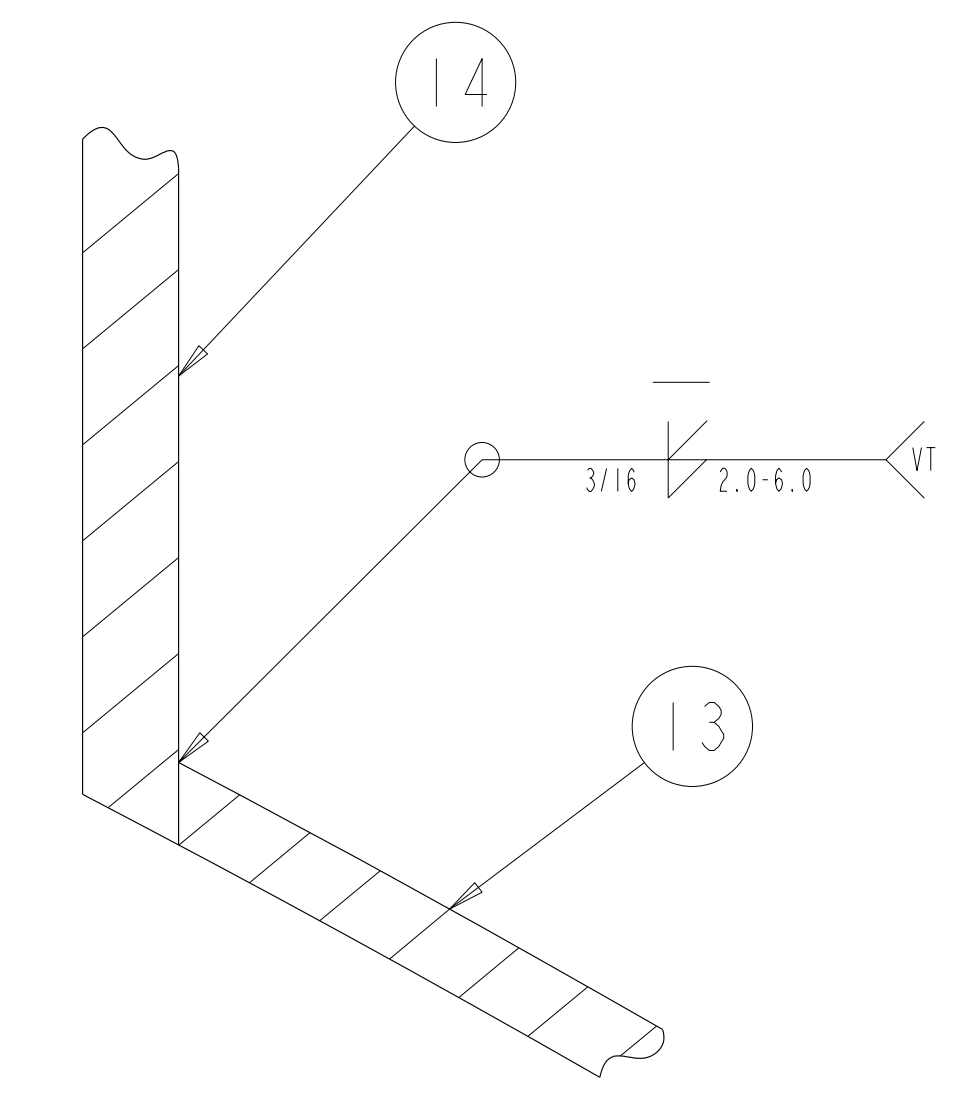

OPTIONAL WELD DETAIL

**RELEASED FOR FABRICATION / INSTALLATION**  
 PPPL Drafting:

Oak Ridge National Laboratory managed for the DEPARTMENT OF ENERGY under U.S. GOVERNMENT CONTRACT DE-AC05-80OR21400 UT-BATTELLE, LLC, Oak Ridge, Tennessee PROJECT NAME:						
NATIONAL COMPACT STELLARATOR EXPERIMENT VACUUM VESSEL PERIOD INSPECTION AND LEAK CHECK ASSEMBLY						
VERSION NO.	PLANT	BLDG	FL	SHT OF	TYPE	CLASS
5	X-10	5700	3	13	A	U
RELEASE LEVEL	SE120-004					REV
Fabrication						2

H  
G  
F  
E  
D  
C  
B  
A

FOR PARTS LIST AND NOTES SEE SHEET 1.

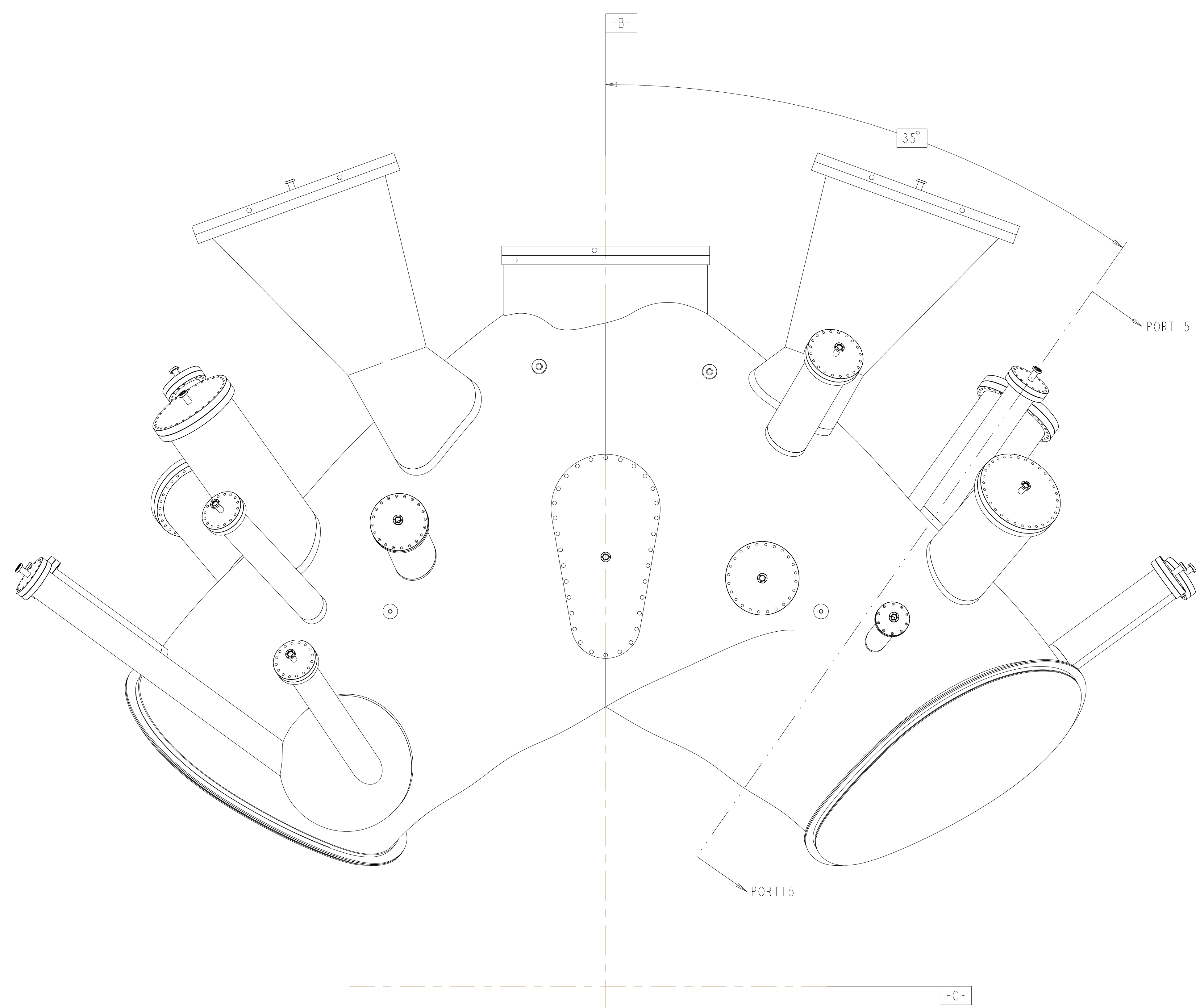

BOTTOM VIEW

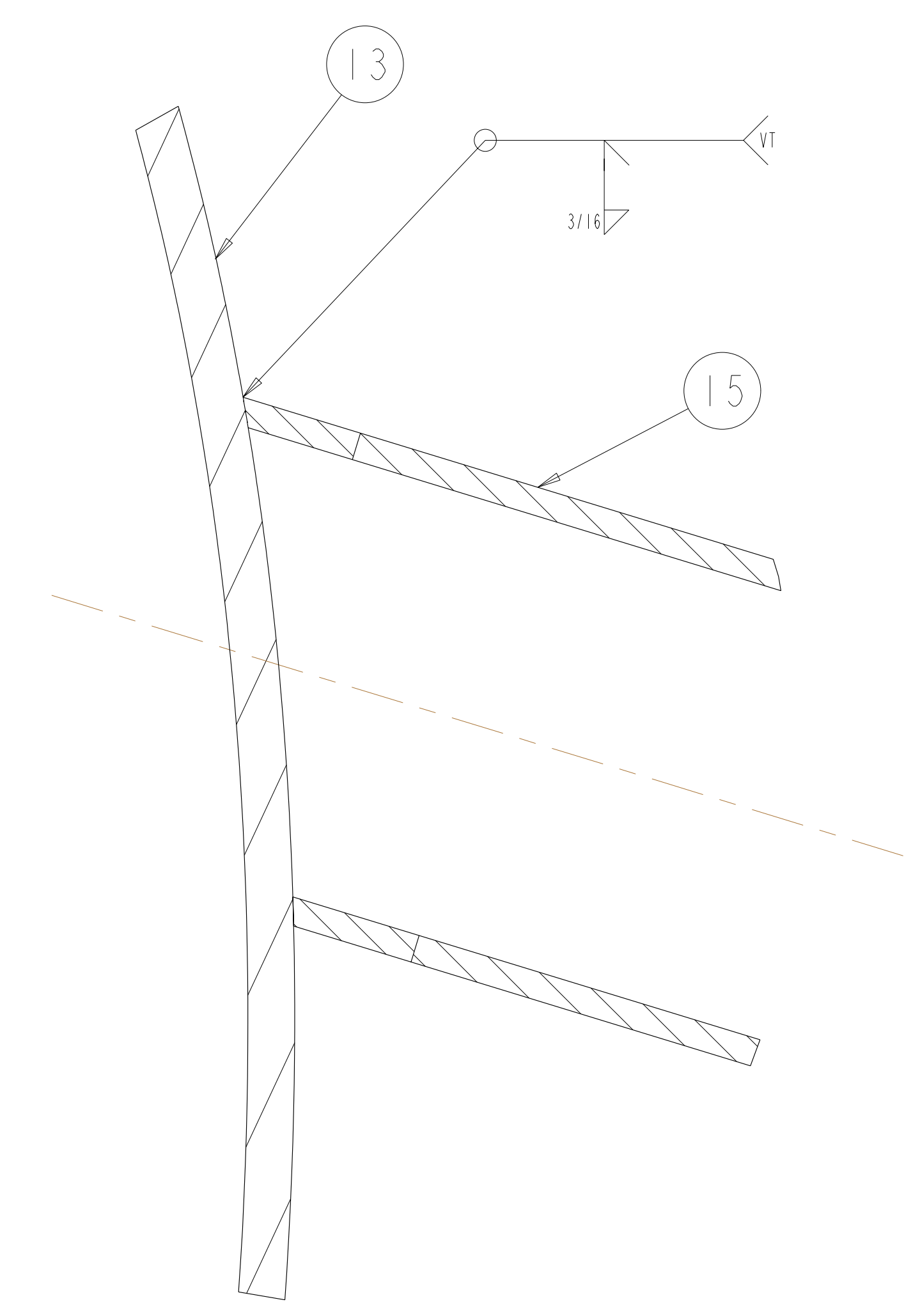

DETAIL X  
SCALE 1.00

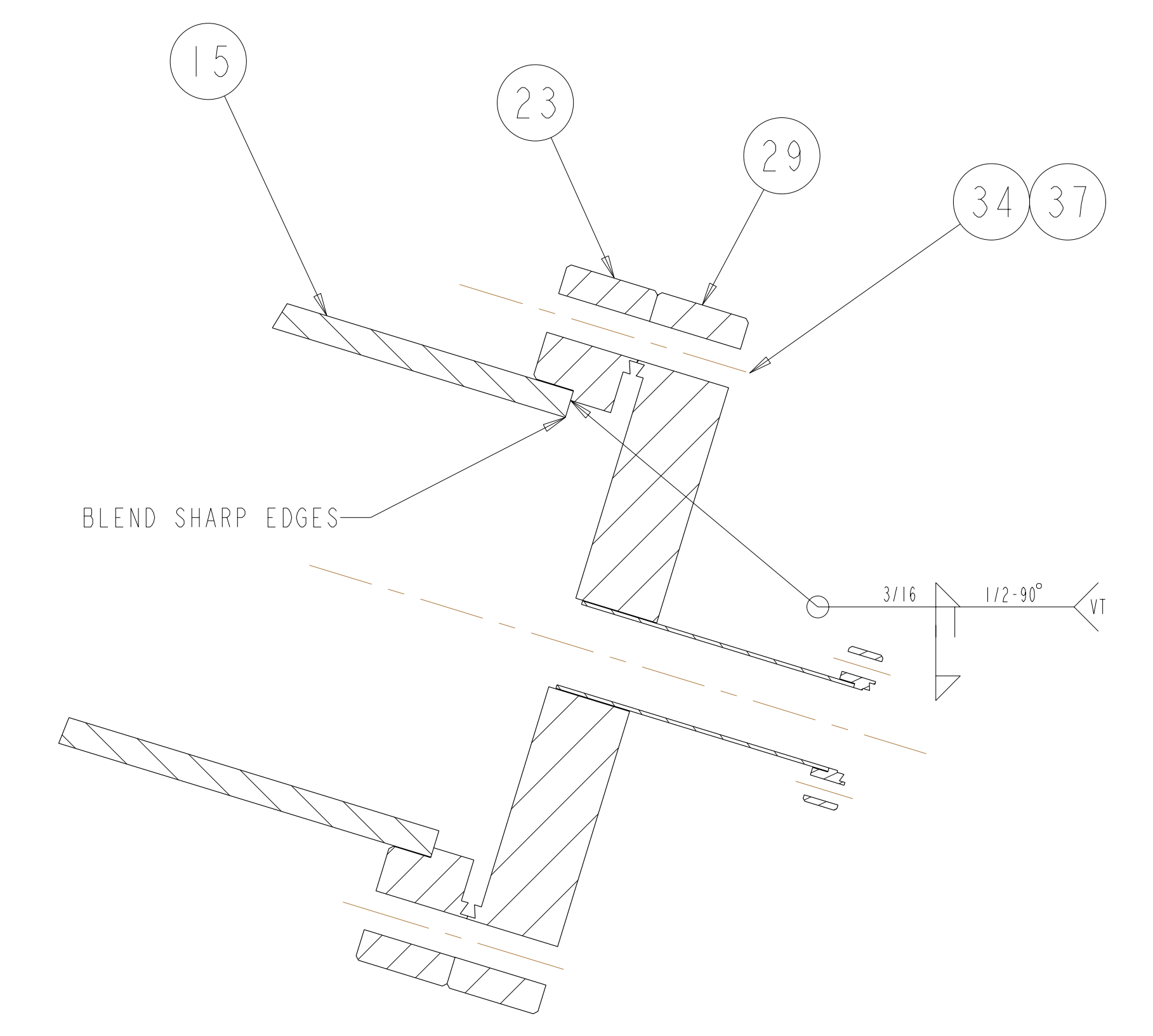

DETAIL Y  
SCALE 1.00

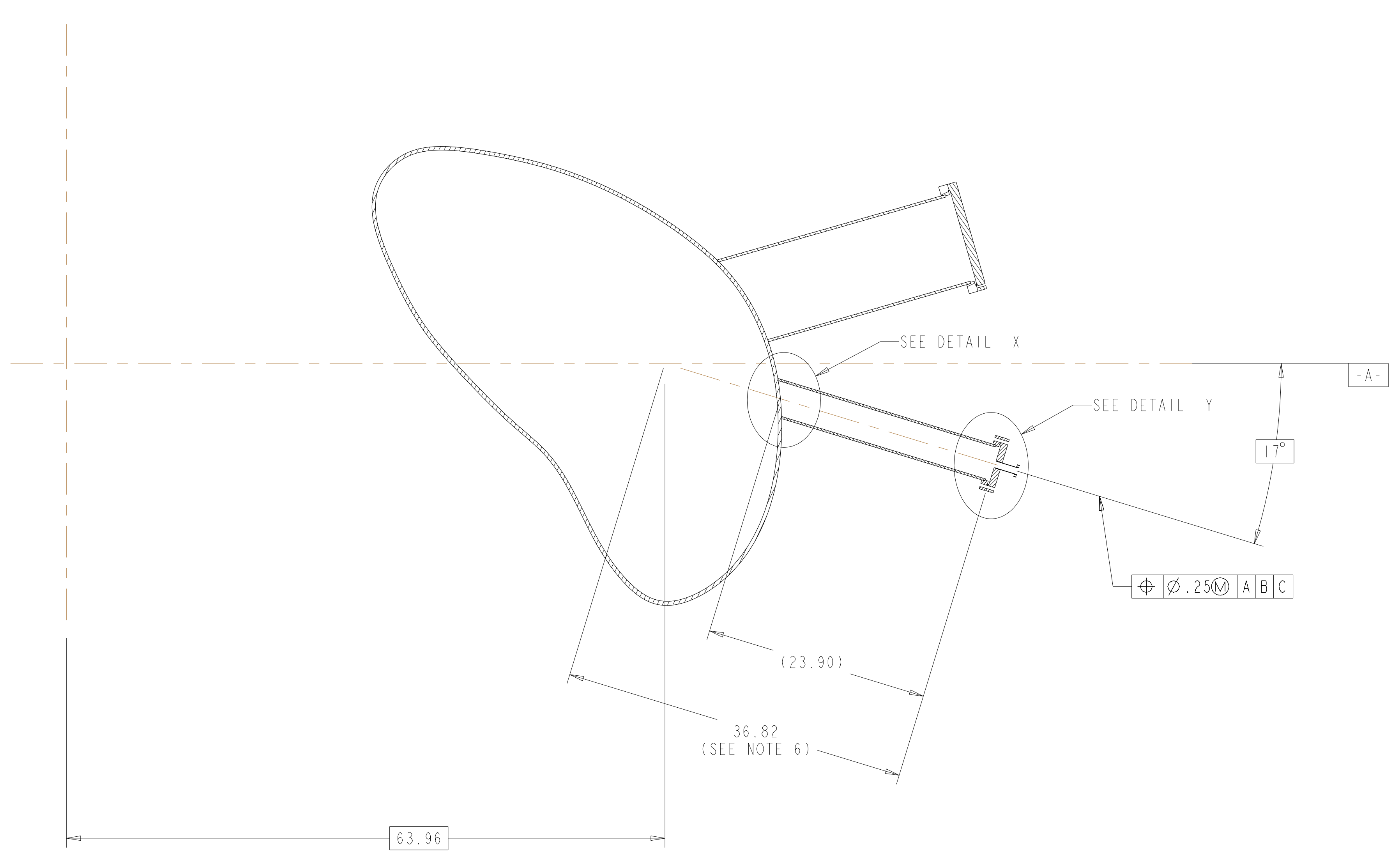

TYPICAL PORT 15A AND 15B  
SECTION PORT15-PORT15

**RELEASED FOR  
FABRICATION / INSTALLATION**  
 PPPL Drafting:

<b>UT-BATTELLE</b>		Oak Ridge National Laboratory managed for the DEPARTMENT OF ENERGY under U.S. GOVERNMENT contract DE-AC05-00OR22725 UT-BATTELLE, LLC, Oak Ridge, Tennessee					
PROJECT NAME		NATIONAL COMPACT STELLARATOR EXPERIMENT					
SUBJECT		VACUUM VESSEL PERIOD INSPECTION AND LEAK CHECK ASSEMBLY					
VERSION NO.	PLANT	BLDG	FL	SHT OF	TYPE	CLASS	
5	X-10	5700	3	14 19	A	U	
RELEASE LEVEL		SE120-004					REV
Fabrication							2

H  
G  
F  
E  
D  
C  
B  
A

FOR PARTS LIST AND NOTES SEE SHEET 1

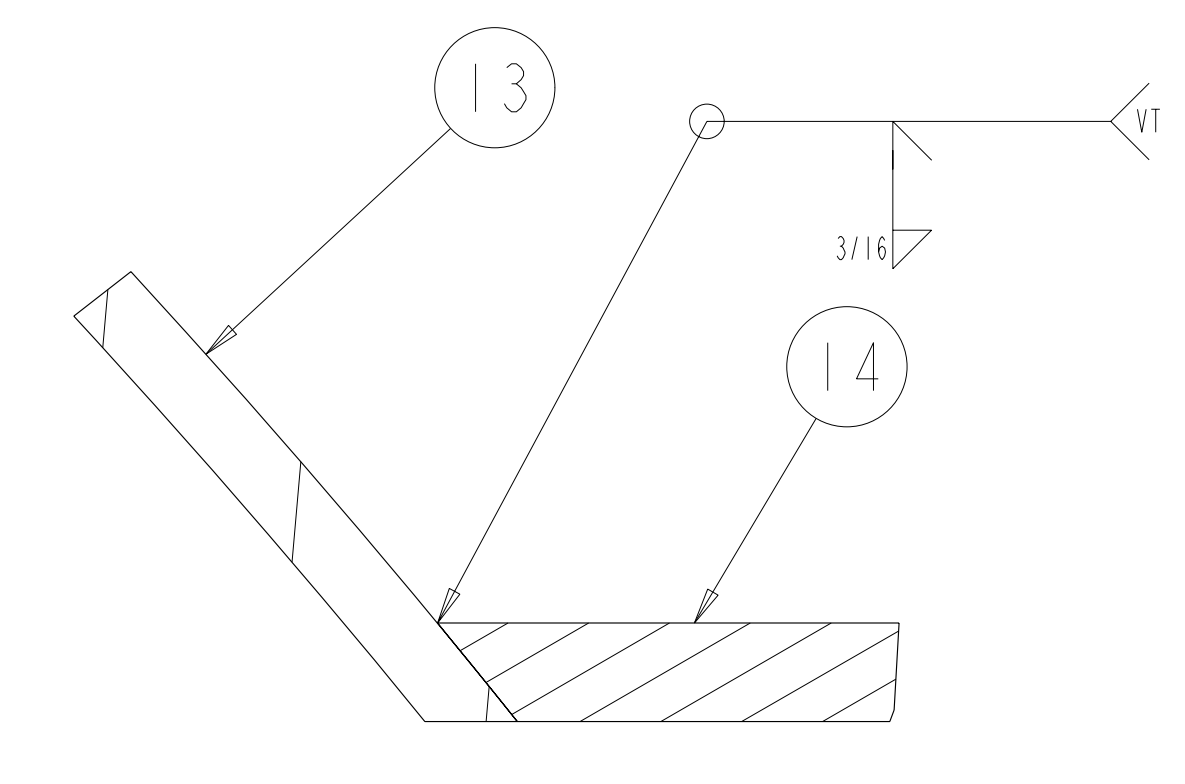
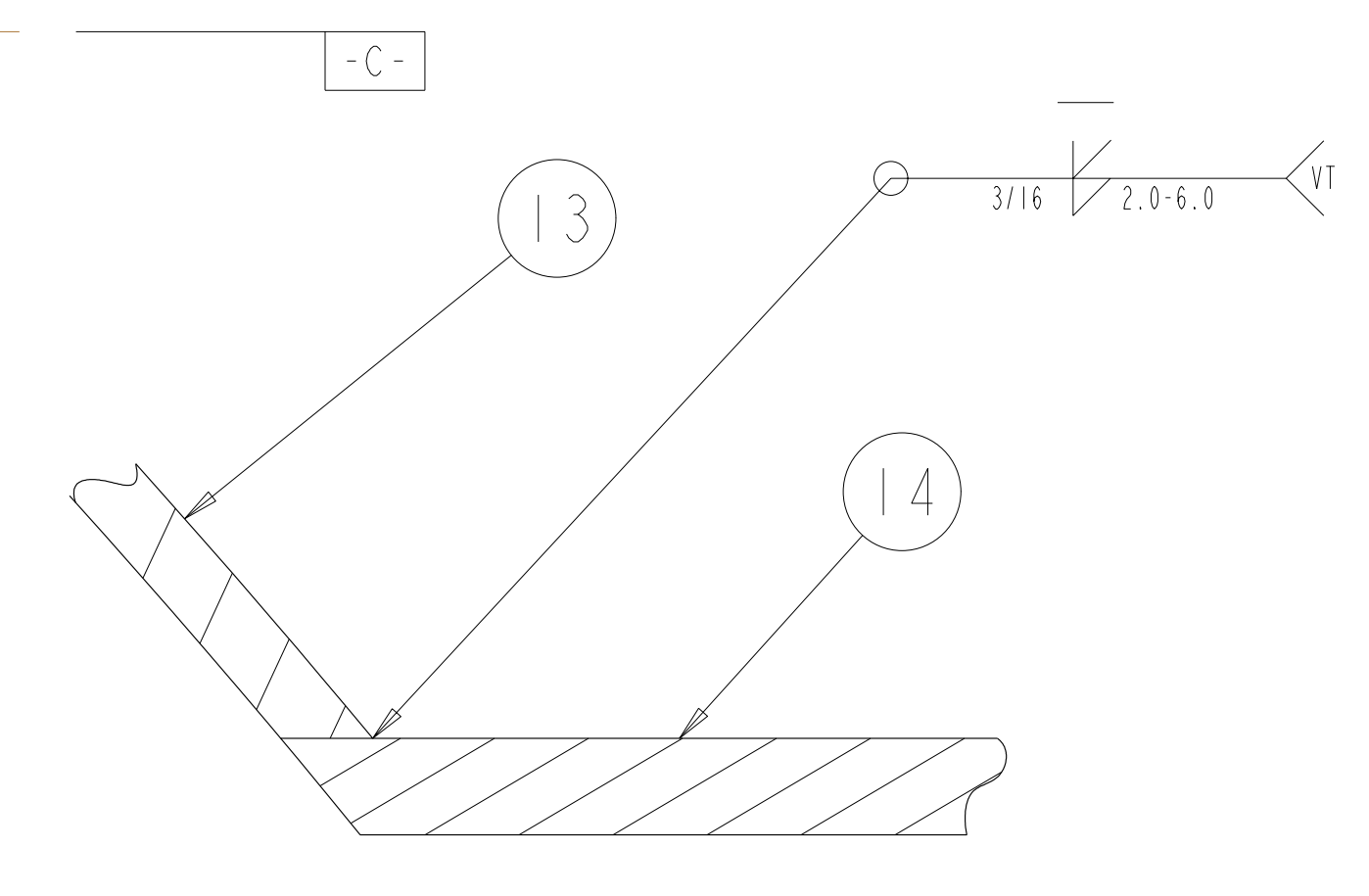
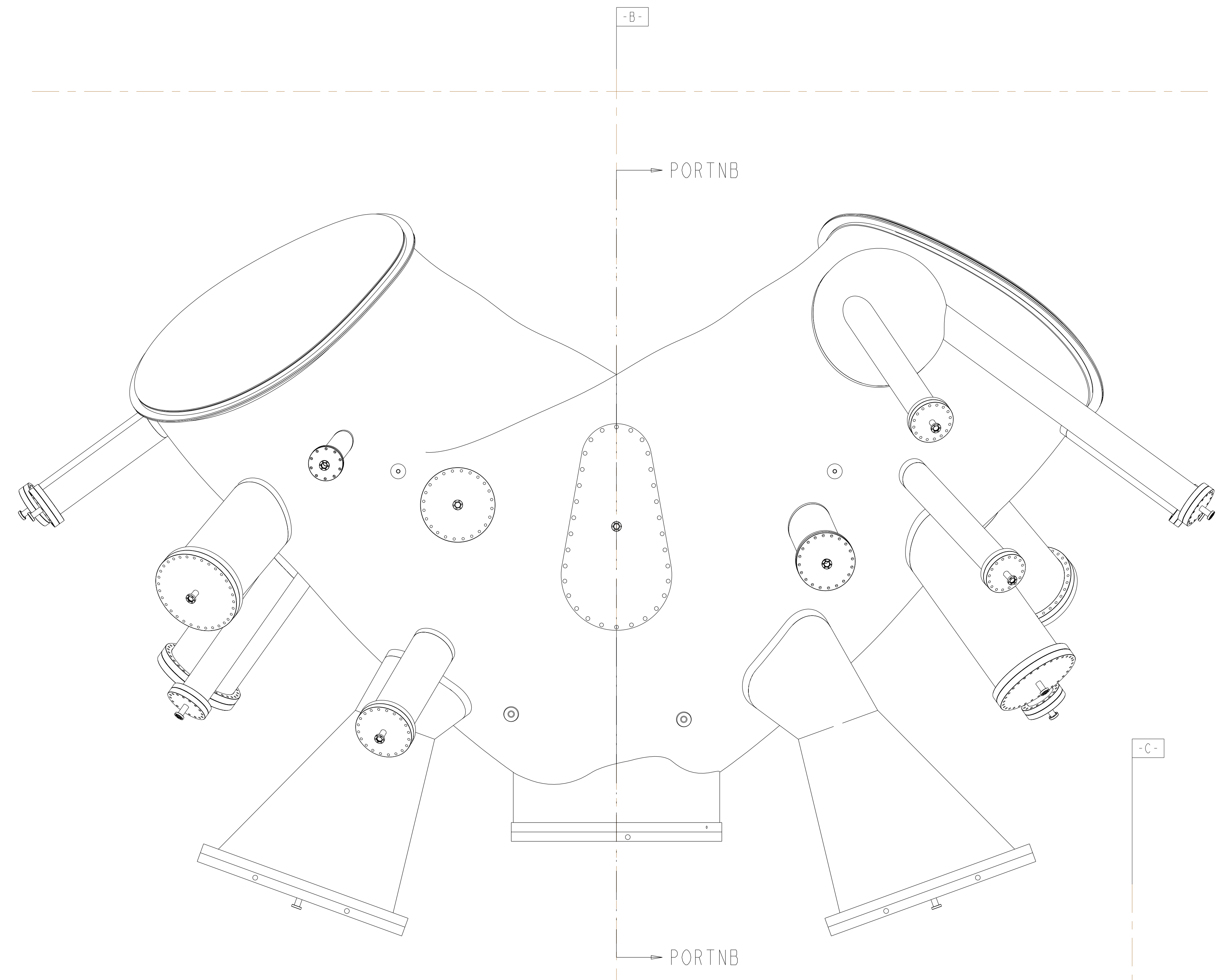

DETAIL X  
 SCALE 1.00

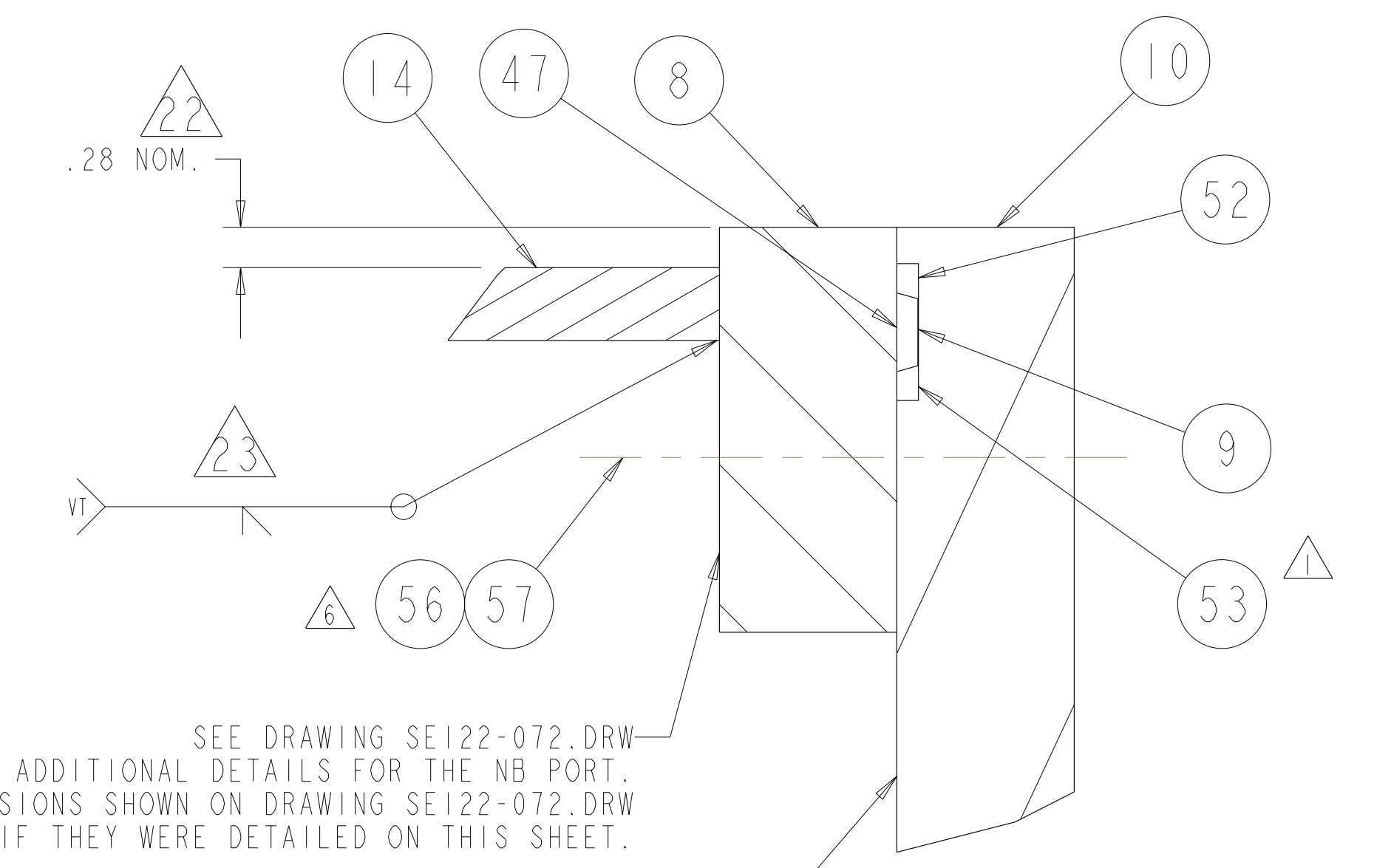

SEE DRAWING SE122-072.DRW FOR ADDITIONAL DETAILS FOR THE NB PORT. DIMENSIONS SHOWN ON DRAWING SE122-072.DRW APPLY AS IF THEY WERE DETAILED ON THIS SHEET.

SEE DRAWING SE122-172.DRW FOR ADDITIONAL DETAILS FOR THE NB PORT. DIMENSIONS SHOWN ON DRAWING SE122-172.DRW APPLY AS IF THEY WERE DETAILED ON THIS SHEET.

DETAIL Y  
 SCALE 1.00

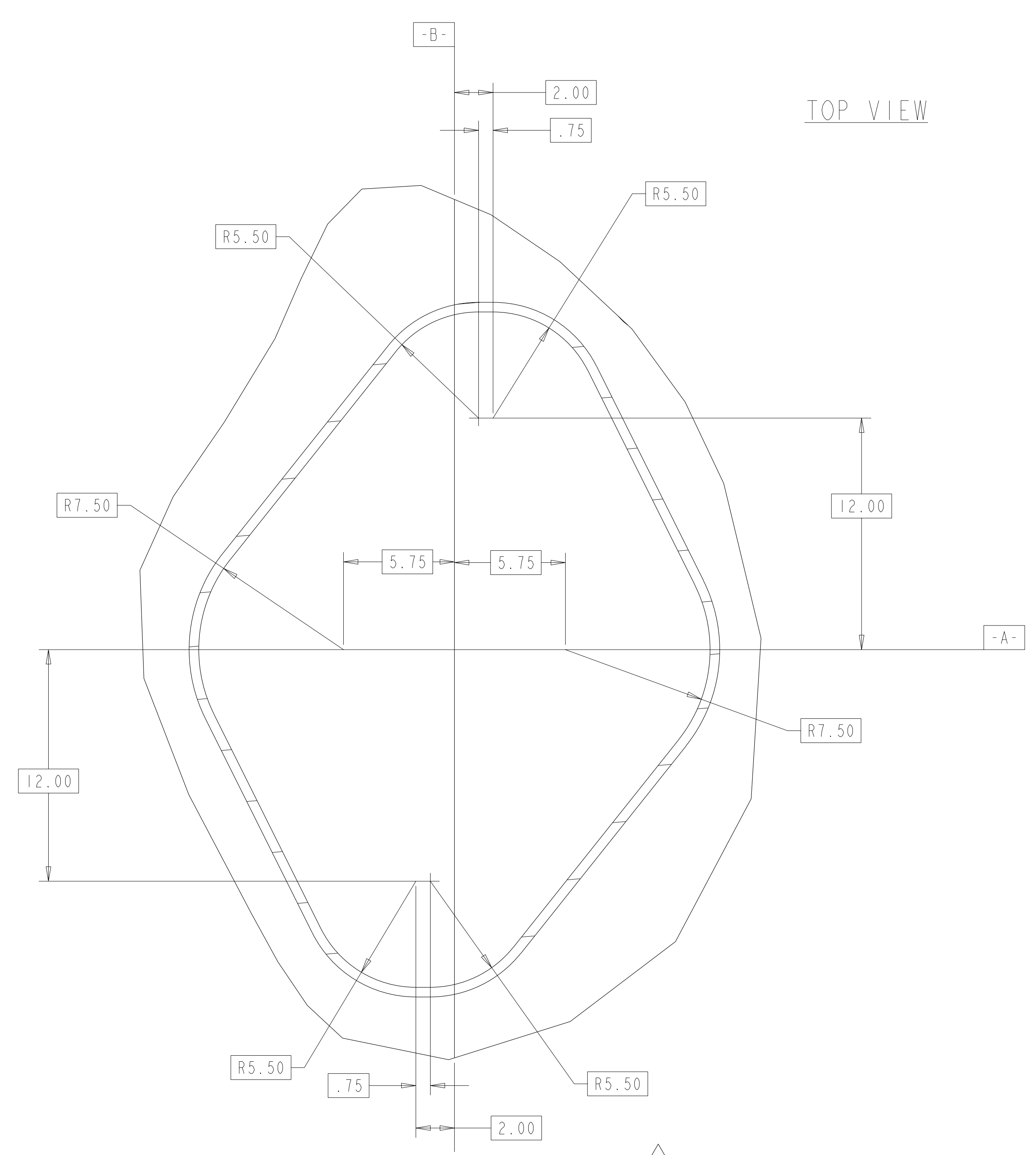

SECTION K-K  
 SCALE 0.25

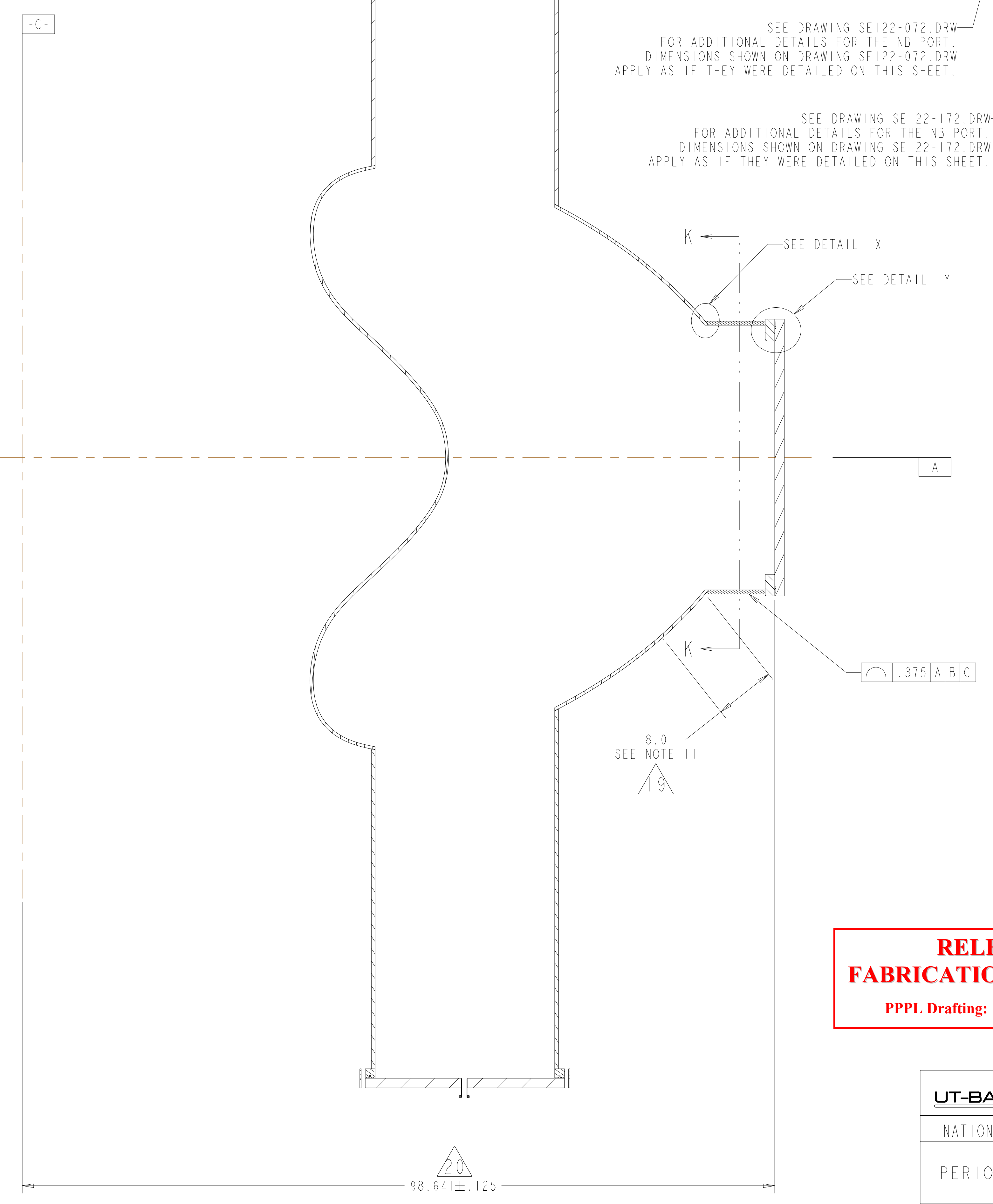

SECTION PORTNB-PORTNB

**RELEASED FOR FABRICATION / INSTALLATION**  
 PPPL Drafting:

Oak Ridge National Laboratory managed for the DEPARTMENT OF ENERGY under U.S. GOVERNMENT contract DE-AC05-00OR22725 UT-BATTELLE, LLC, Oak Ridge, Tennessee PROJECT NAME						
NATIONAL COMPACT STELLARATOR EXPERIMENT VACUUM VESSEL PERIOD INSPECTION AND LEAK CHECK ASSEMBLY						
VERSION NO.	PLANT	BLDG	FL	SHT OF	TYPE	CLASS
5	X-10	5700	3	15	A	U
RELEASE LEVEL		SE120-004		REV		2
Fabrication						

SE120-004

FOR PARTS LIST AND NOTES SEE SHEET 1.

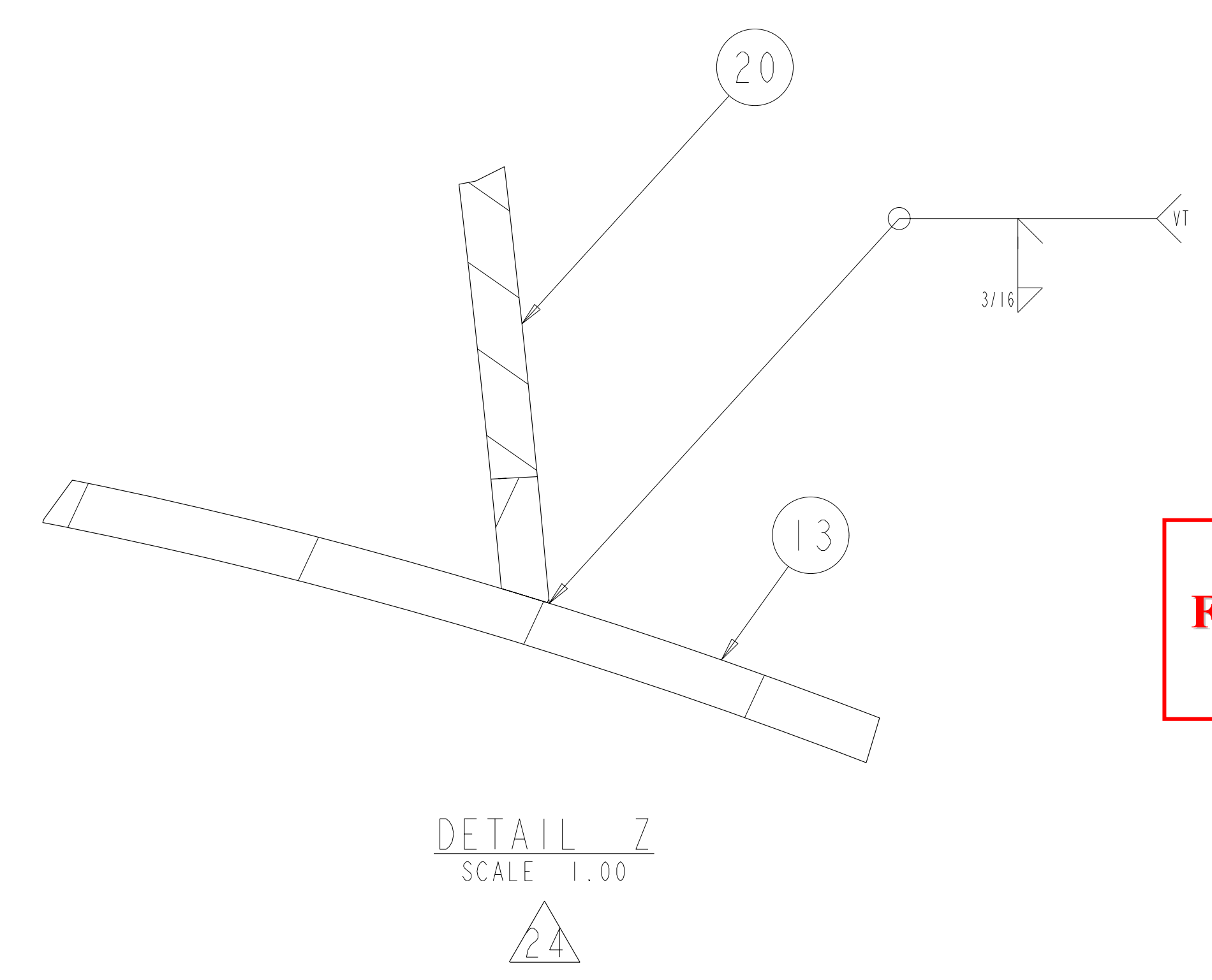
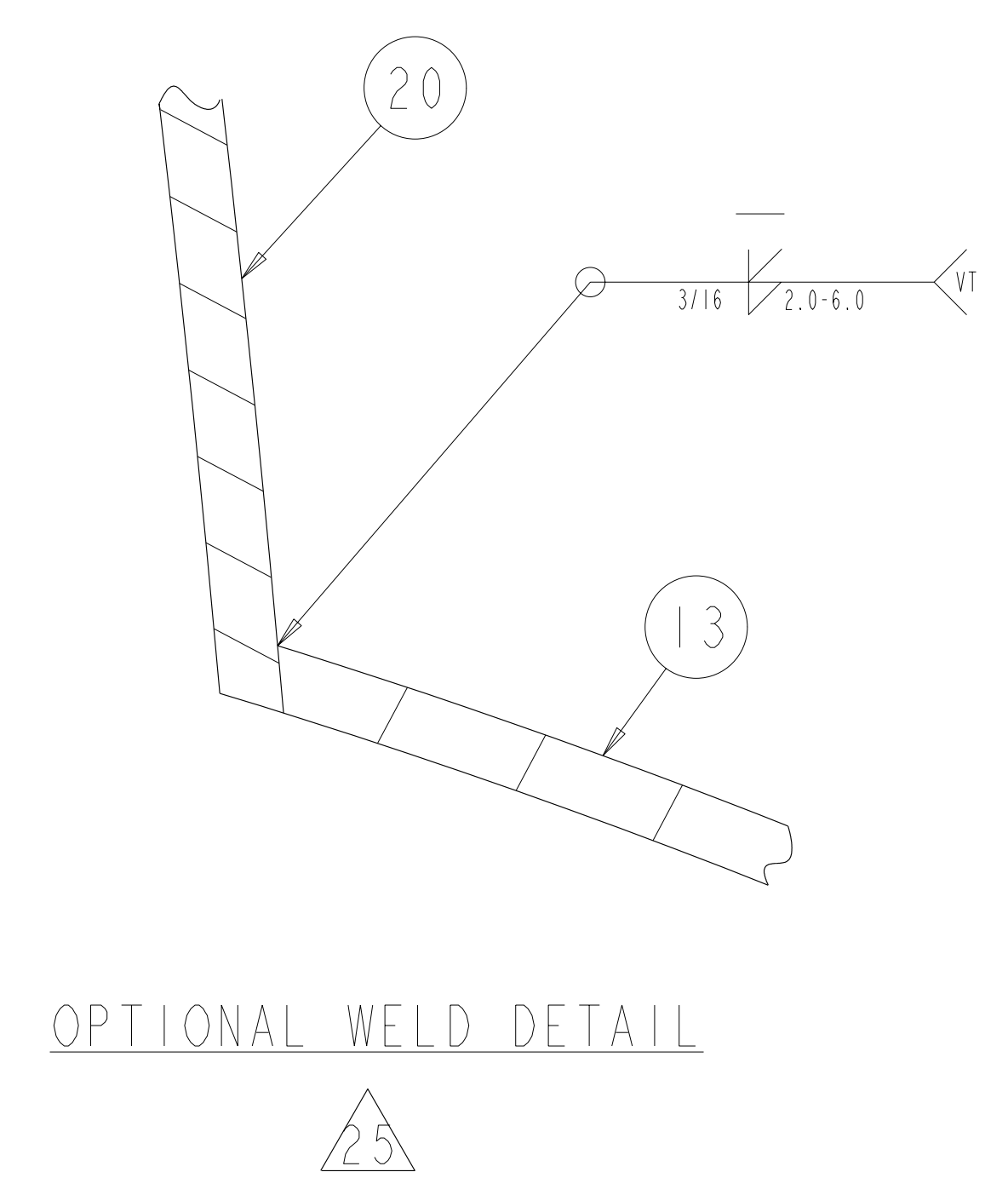
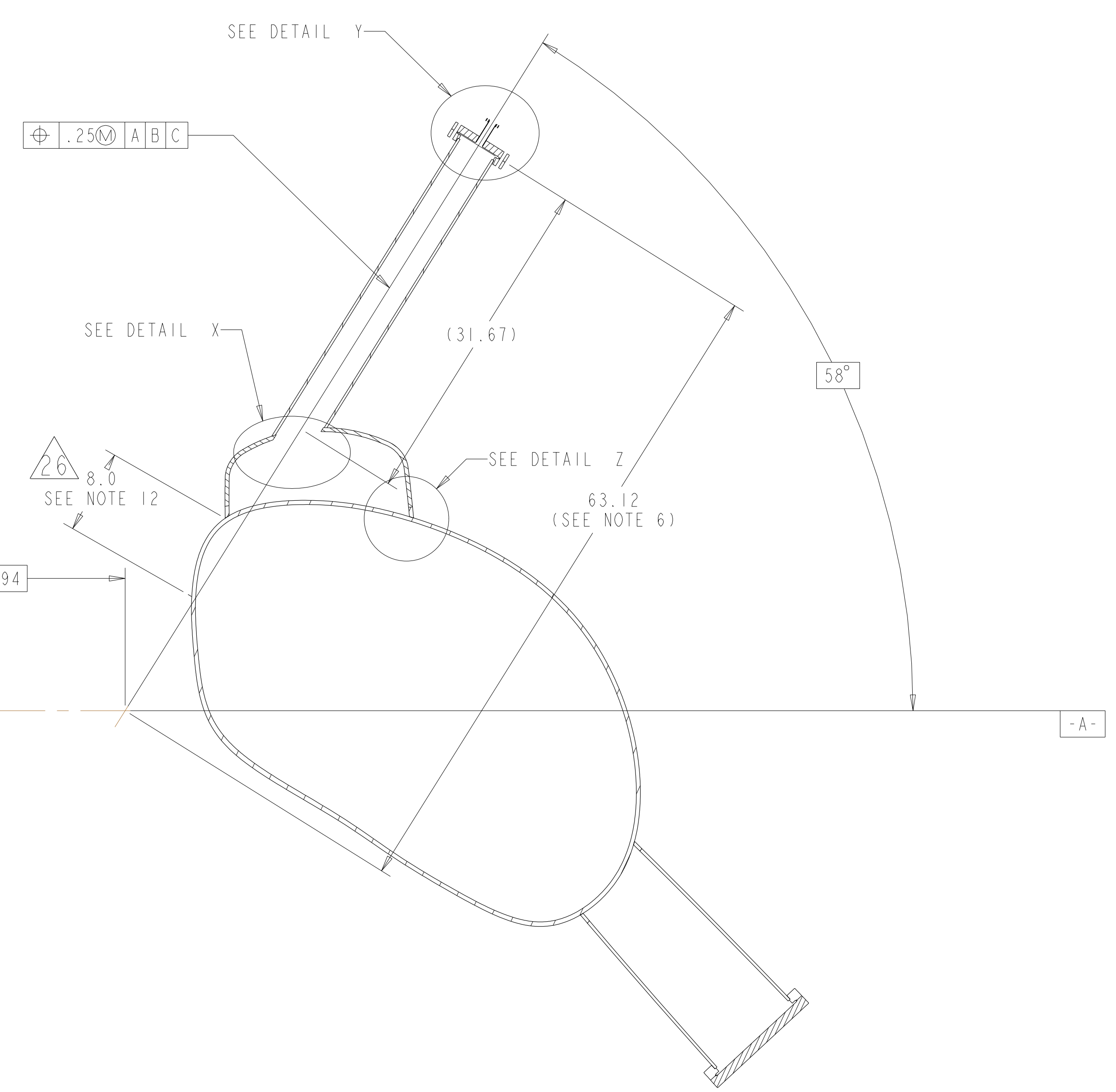
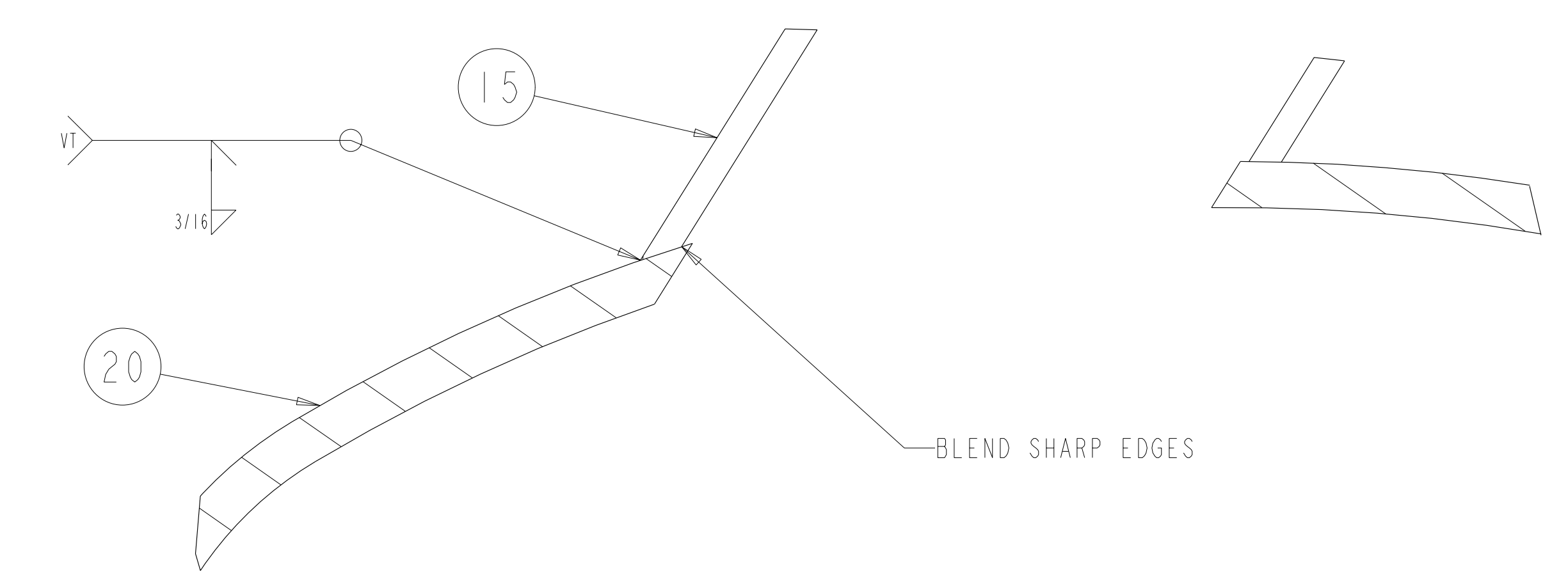
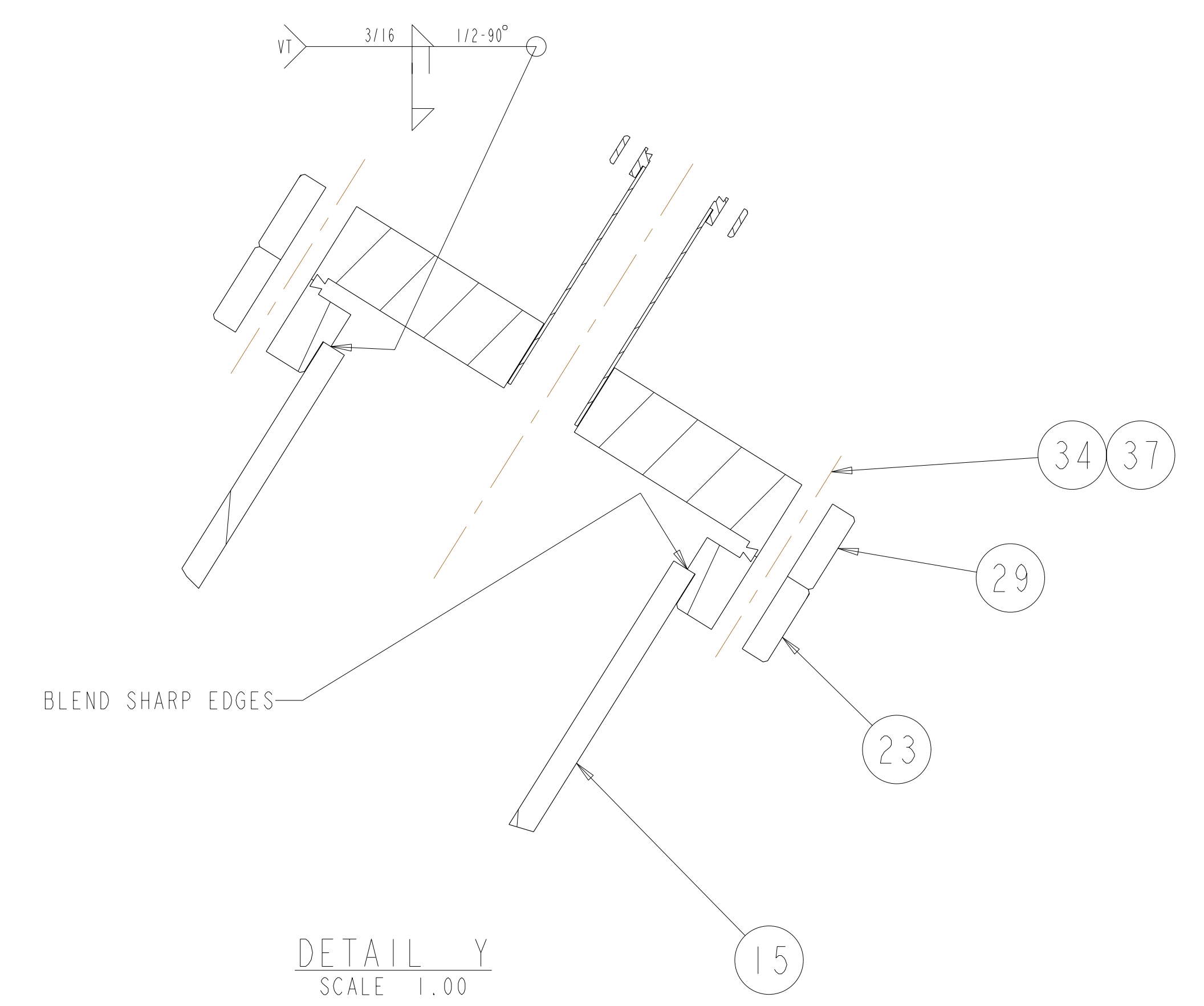
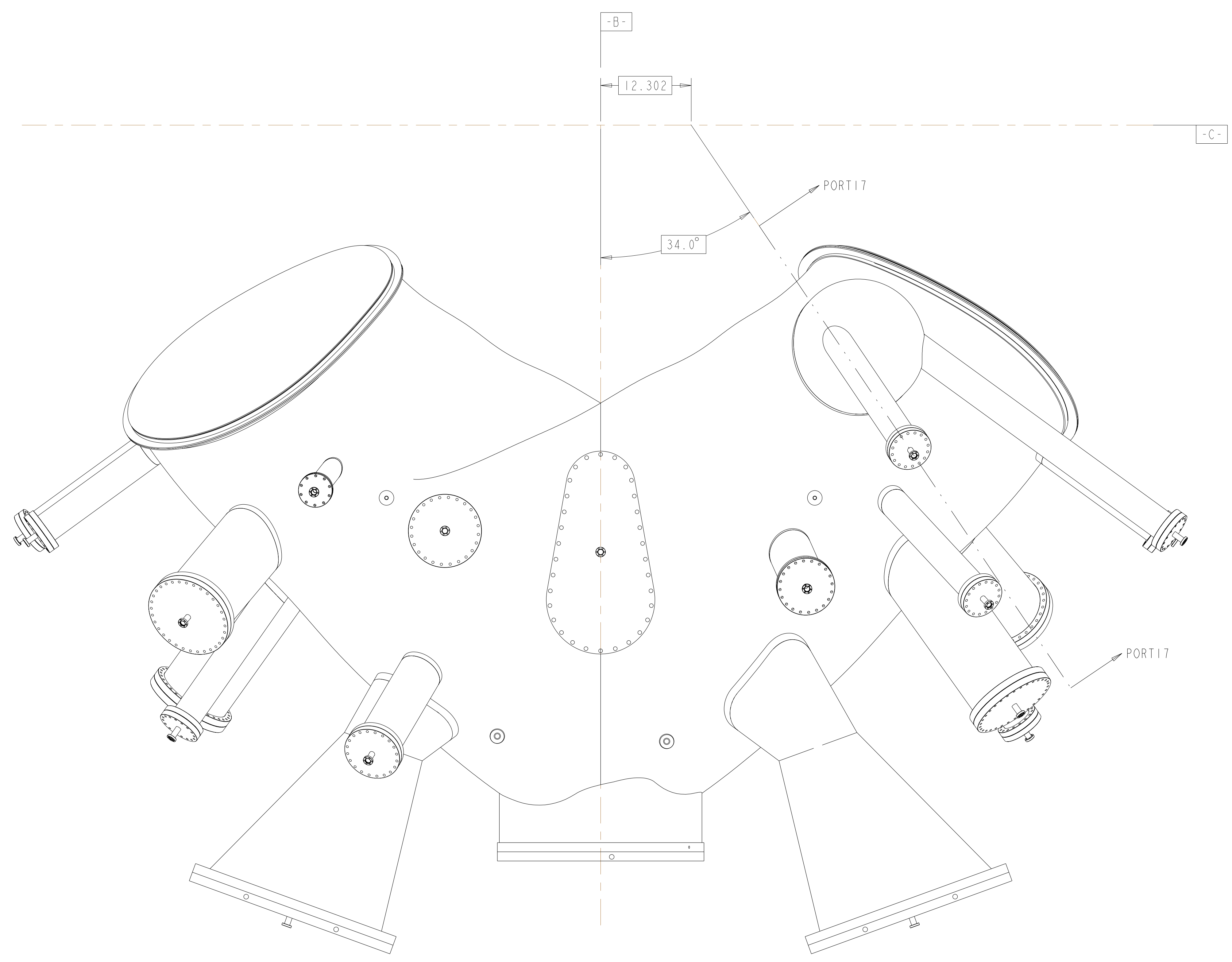

**RELEASED FOR  
FABRICATION / INSTALLATION**  
 PPPL Drafting:

Oak Ridge National Laboratory managed for the DEPARTMENT OF ENERGY under U.S. GOVERNMENT contract DE-AC05-00OR22725 UT-BATTELLE, LLC, Oak Ridge, Tennessee PROJECT NAME						
NATIONAL COMPACT STELLARATOR EXPERIMENT VACUUM VESSEL PERIOD INSPECTION AND LEAK CHECK ASSEMBLY						
VERSION NO.	PLANT	BLDG	FL	SHT OF	TYPE	CLASS
5	X-10	5700	3	16	19	A
RELEASE LEVEL		SE120-004			REV	
Fabrication					2	

H  
G  
F  
E  
D  
C  
B  
A



FOR PARTS LIST AND NOTES SEE SHEET 1.

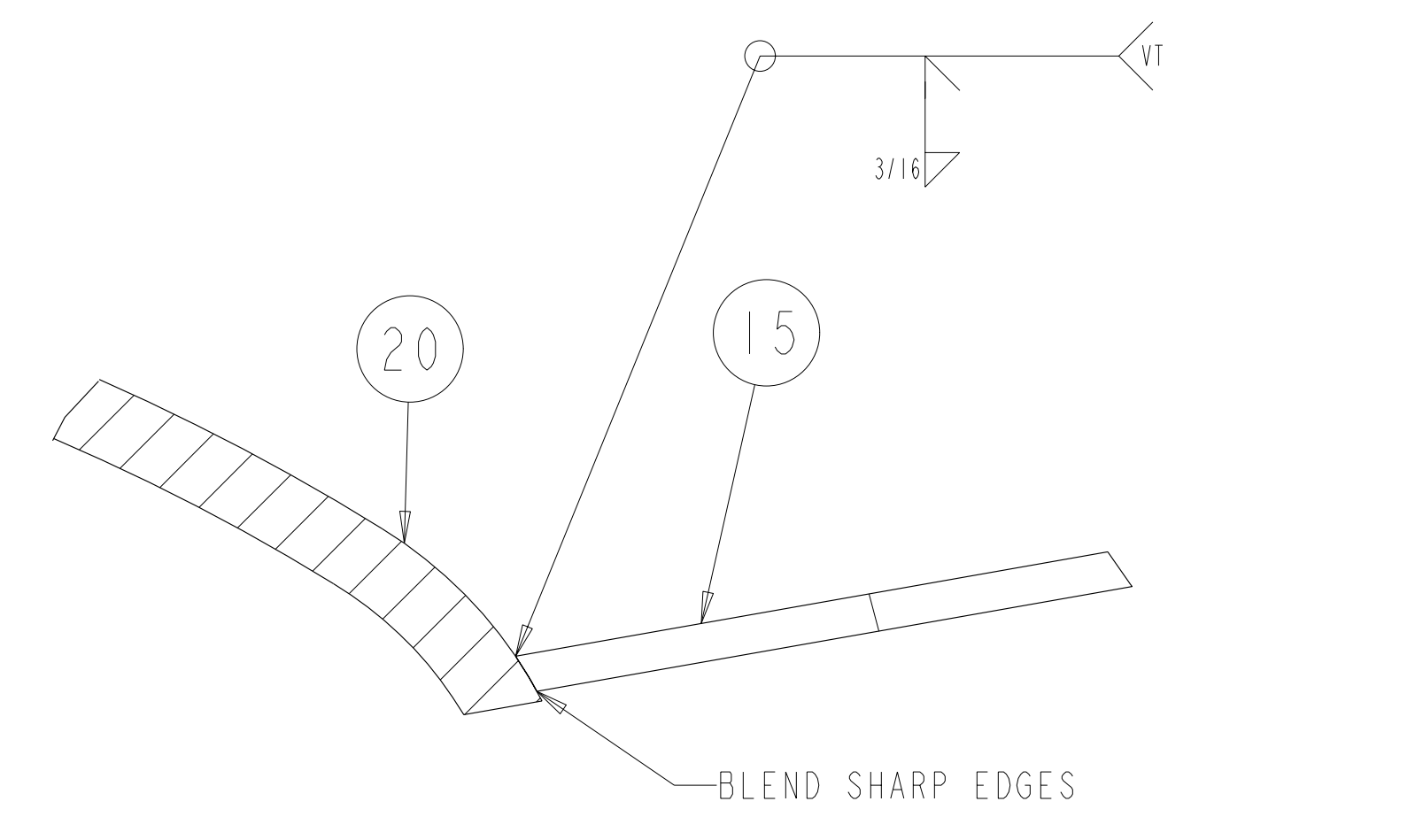
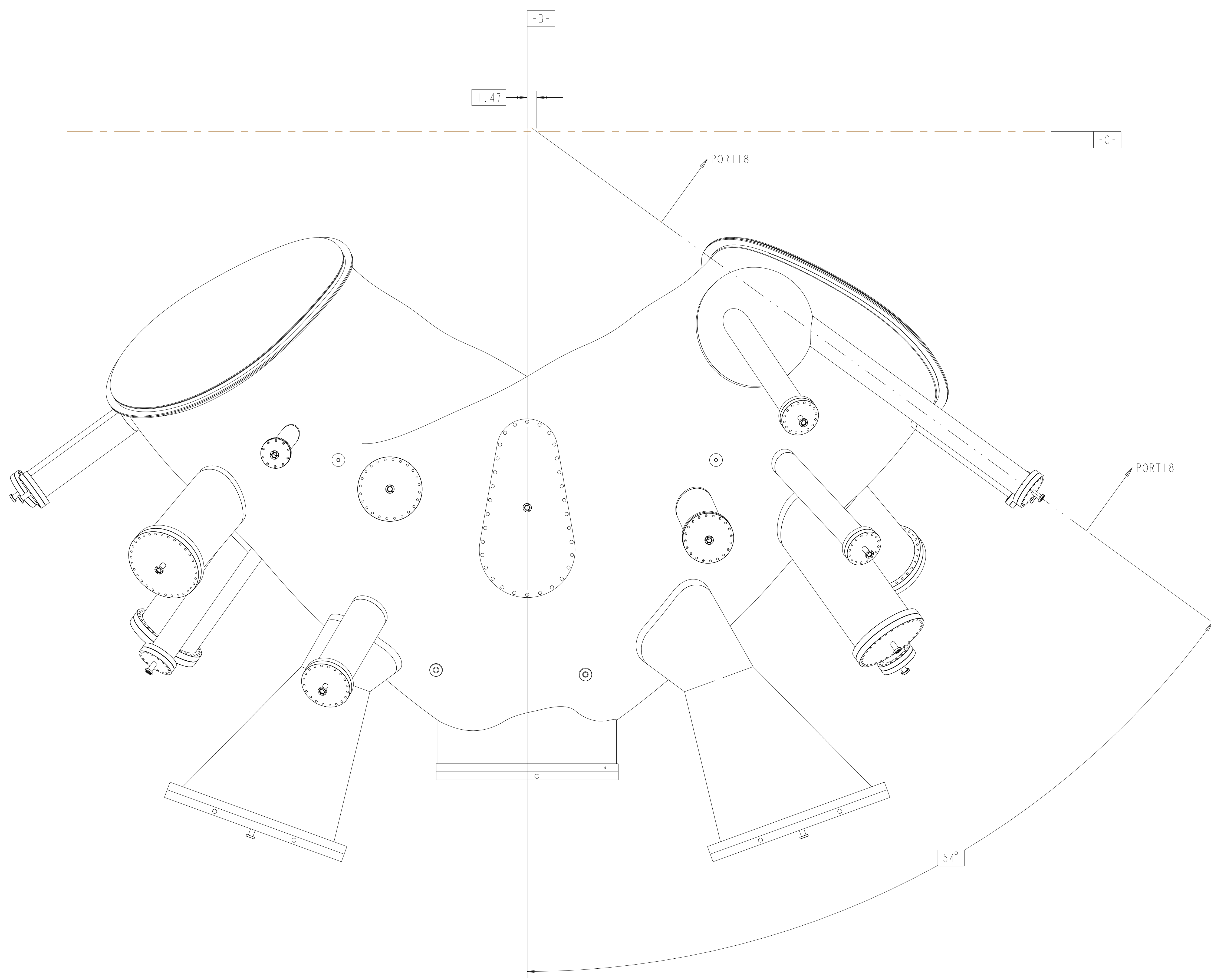

DETAIL X  
 SCALE 1.00

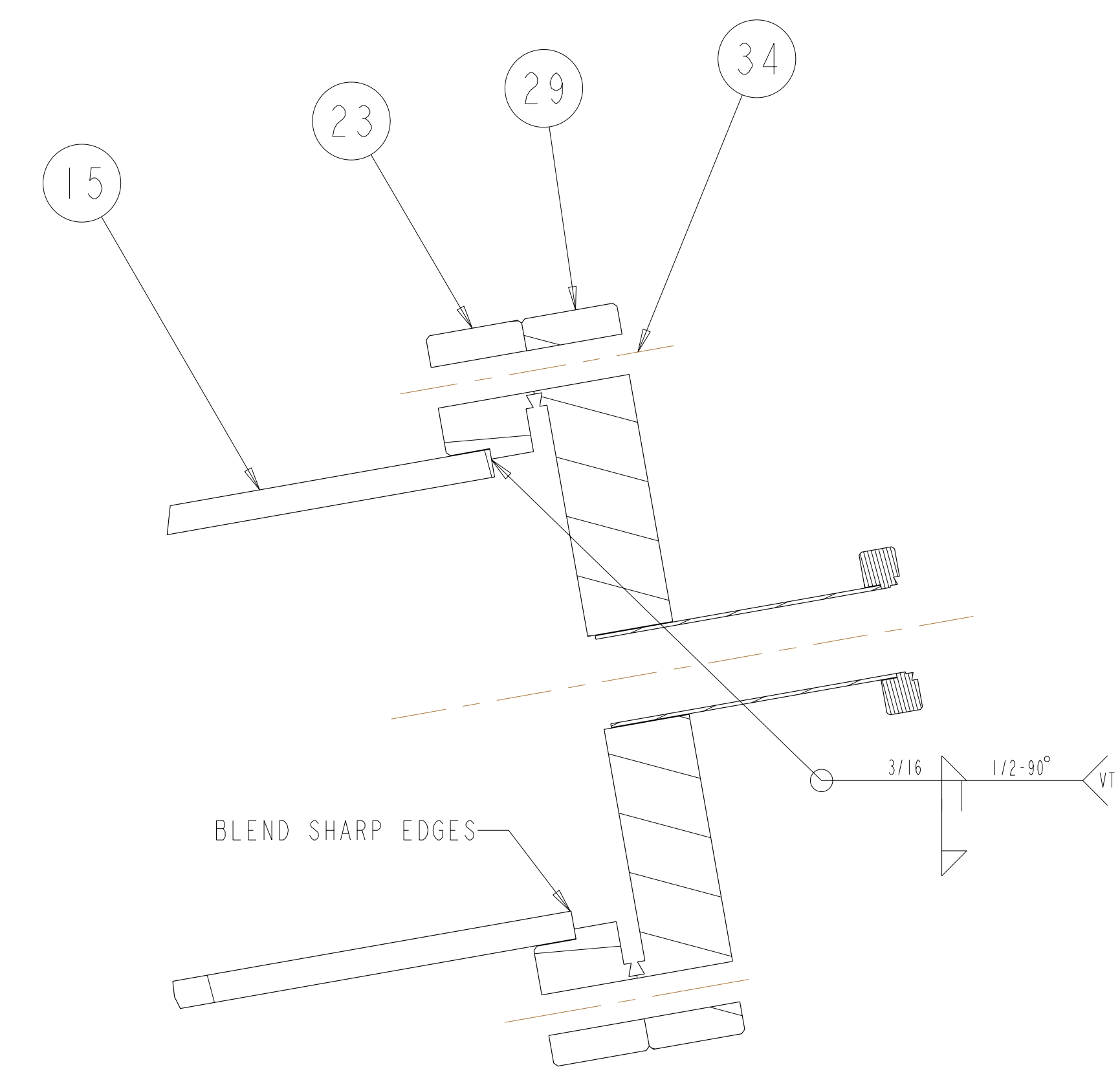

DETAIL Y  
 SCALE 1.000

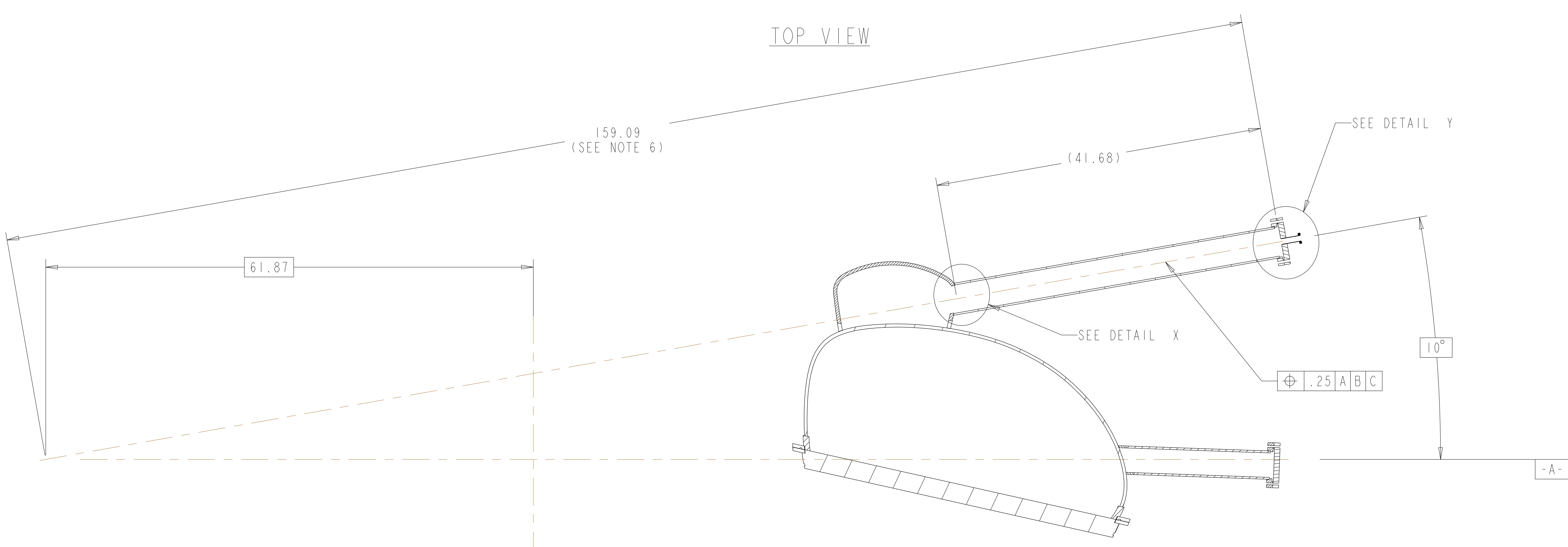

TYPICAL PORT 18A AND 18B  
 SECTION PORT18-PORT18

**RELEASED FOR  
 FABRICATION / INSTALLATION**  
 PPPL Drafting:

<b>UT-BATTELLE</b>		Oak Ridge National Laboratory managed for the DEPARTMENT OF ENERGY under U.S. GOVERNMENT contract DE-AC05-00OR22725 UT-BATTELLE, LLC, Oak Ridge, Tennessee						
PROJECT NAME								
NATIONAL COMPACT STELLARATOR EXPERIMENT								
VACUUM VESSEL								
PERIOD INSPECTION AND LEAK CHECK								
ASSEMBLY								
VERSION NO.	PLANT	BLDG	FL	SHT OF	TYPE	CLASS		
5	X-10	5700	3	17 19	A	U		
RELEASE LEVEL		SE120-004					REV	
Fabrication							2	

H  
G  
F  
E  
D  
C  
B  
A

FOR PARTS LIST AND NOTES SEE SHEET 1.

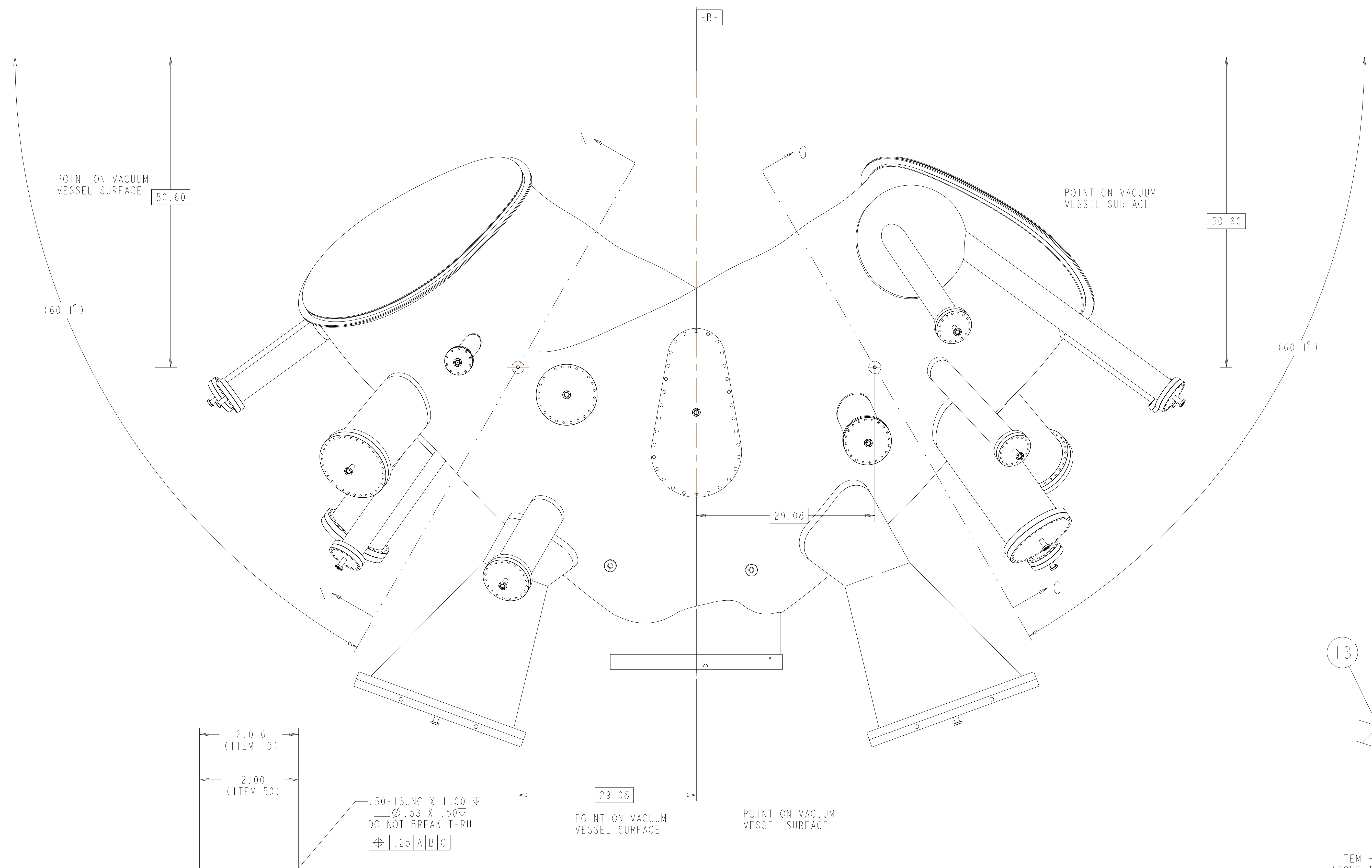

TOP VIEW

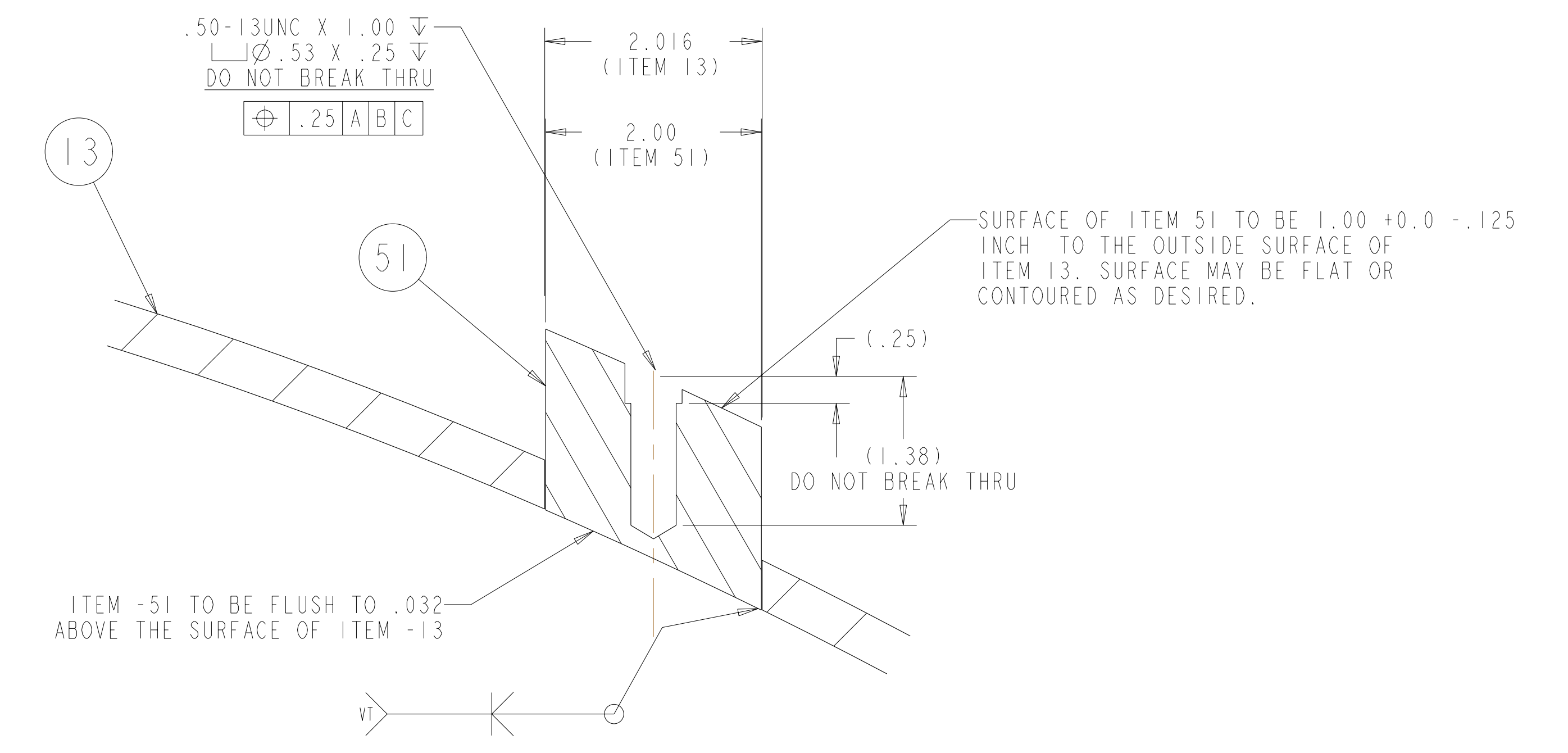

DETAIL X  
TYPICAL 2 PLACES  
SCALE 1.00

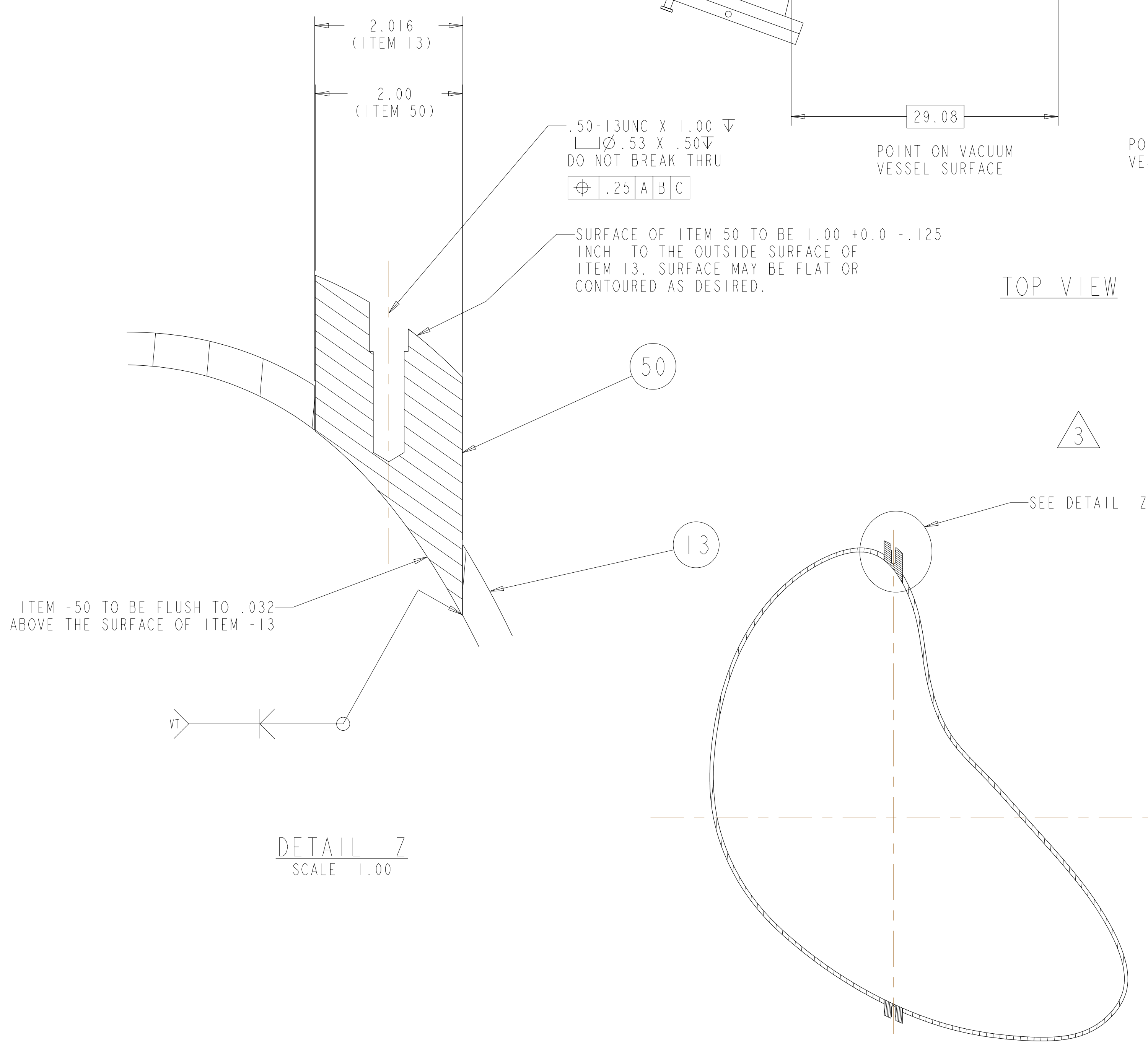

DETAIL Z  
SCALE 1.00

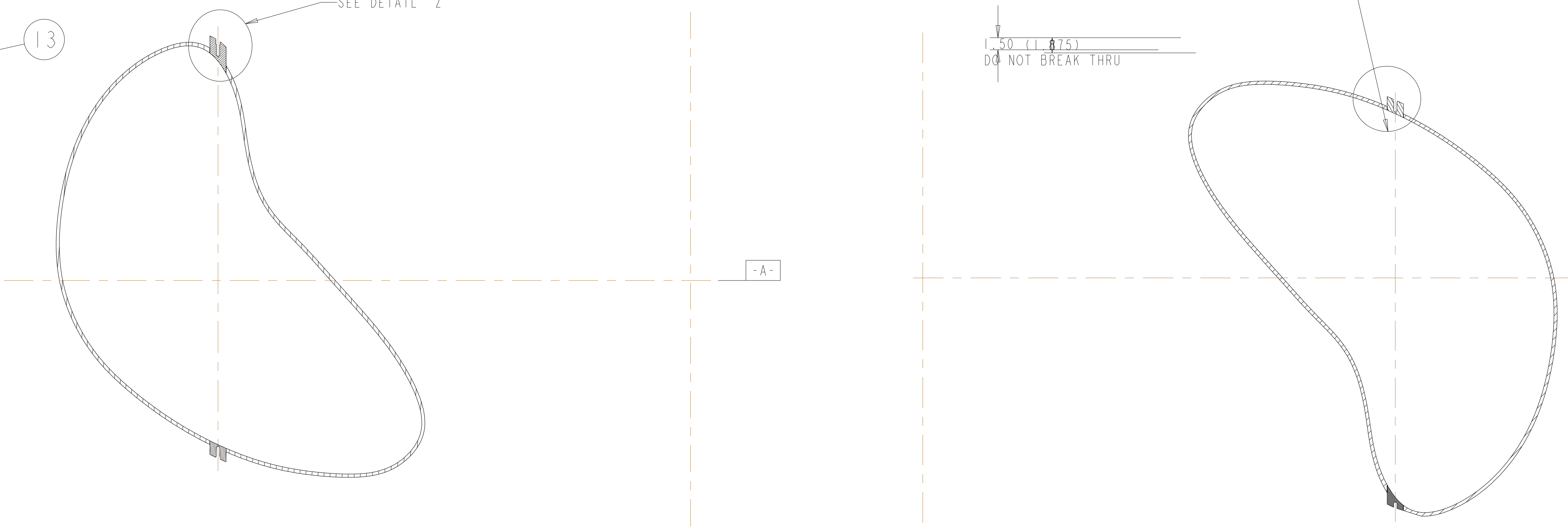

SECTION N-N

SECTION G-G

**RELEASED FOR  
FABRICATION / INSTALLATION**

PPPL Drafting:

UT-BATTELLE		Oak Ridge National Laboratory managed for the DEPARTMENT OF ENERGY under U.S. GOVERNMENT contract DE-AC05-00OR22725 UT-BATTELLE, LLC, Oak Ridge, Tennessee					
NATIONAL COMPACT STELLARATOR EXPERIMENT							
VACUUM VESSEL PERIOD INSPECTION AND LEAK CHECK ASSEMBLY							
VERSION NO.	PLANT	BLDG	FL	SHT OF	TYPE	CLASS	
3+	X-10	5700	3	8	19	A	U
RELEASE LEVEL Fabrication		SE120-004					REV 2

SE120-004

A

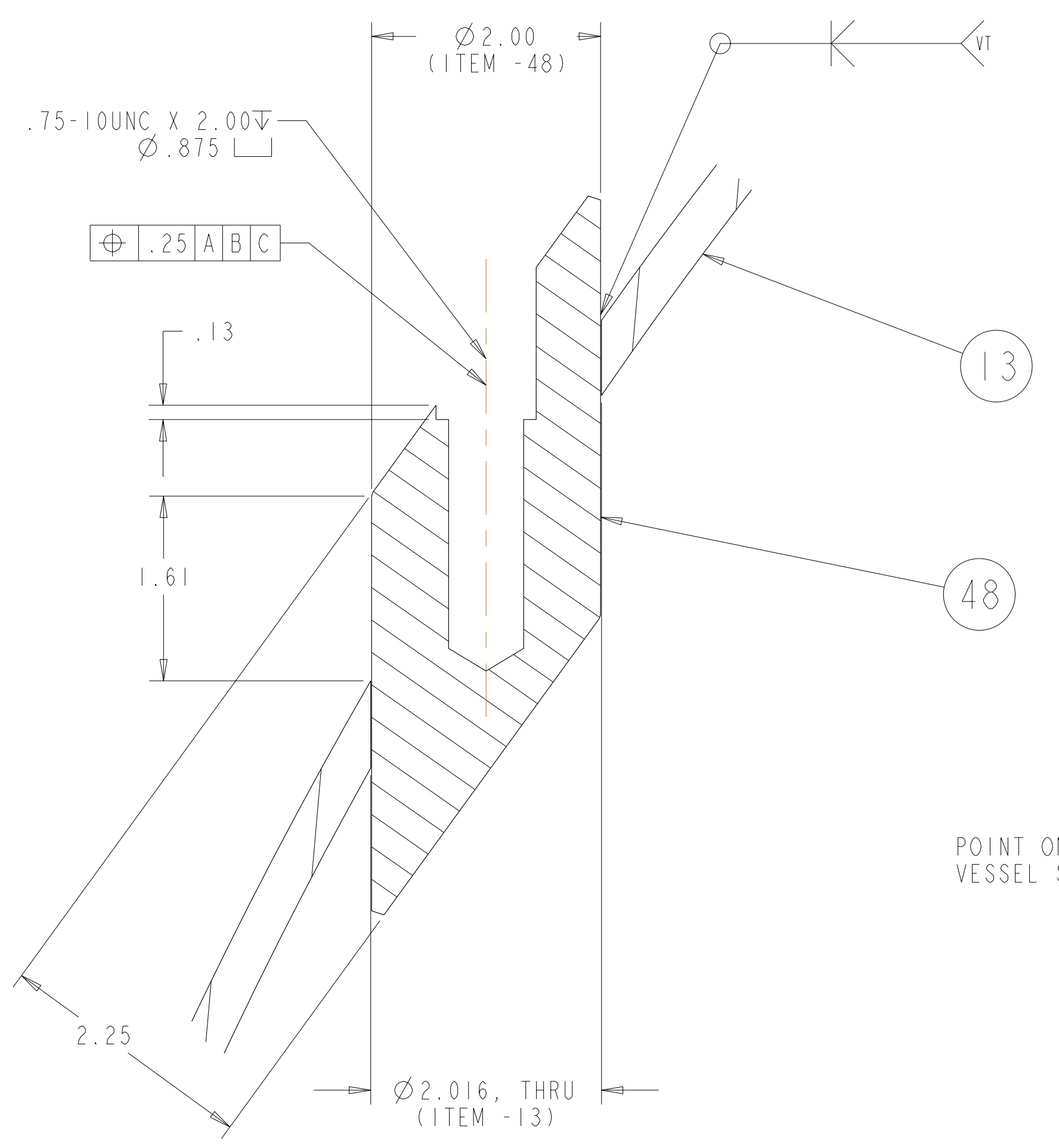

DETAIL W  
SCALE 1.00

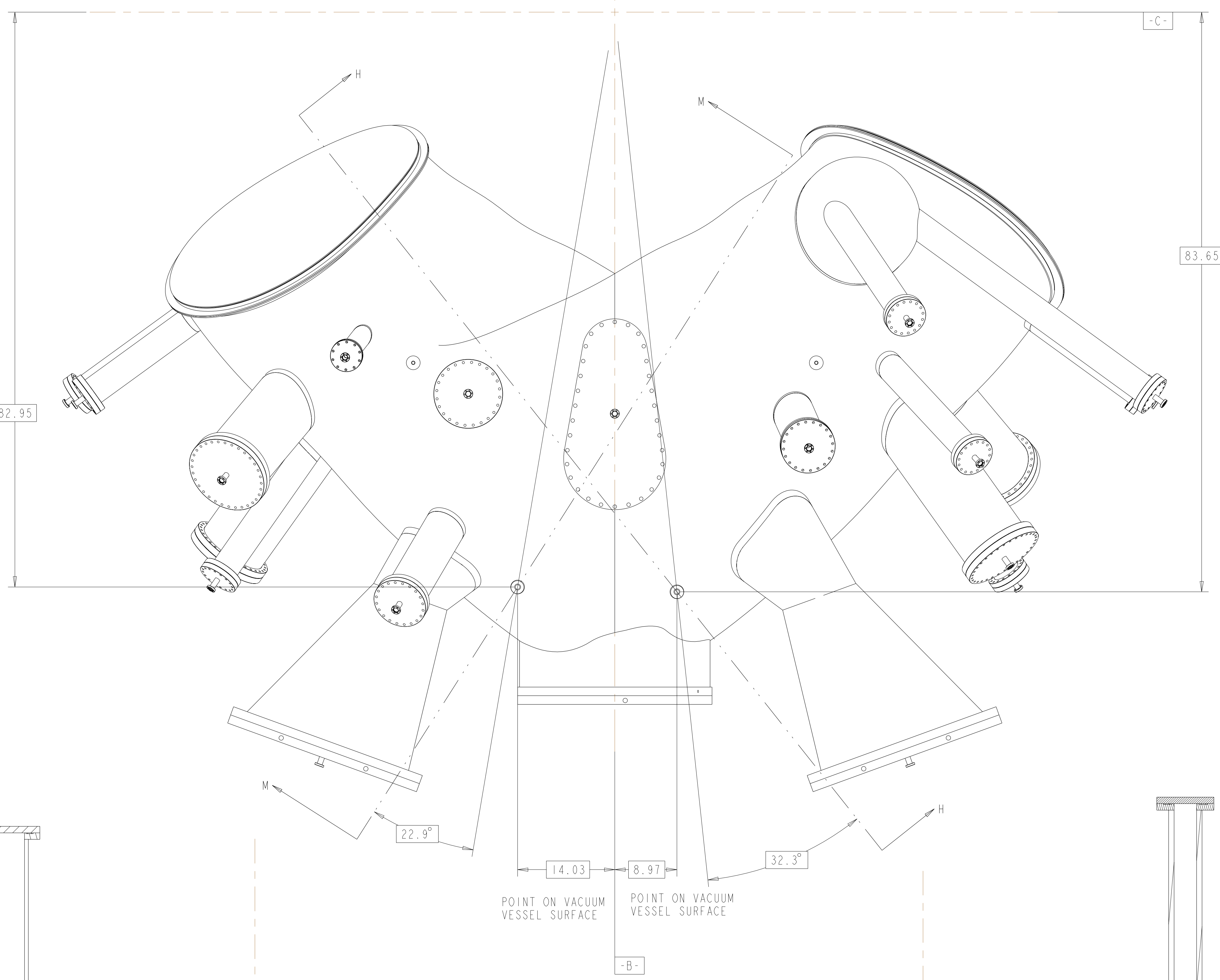

TOP VIEW

FOR PARTS LIST AND NOTES SEE SHEET 1.

POINT ON VACUUM VESSEL SURFACE

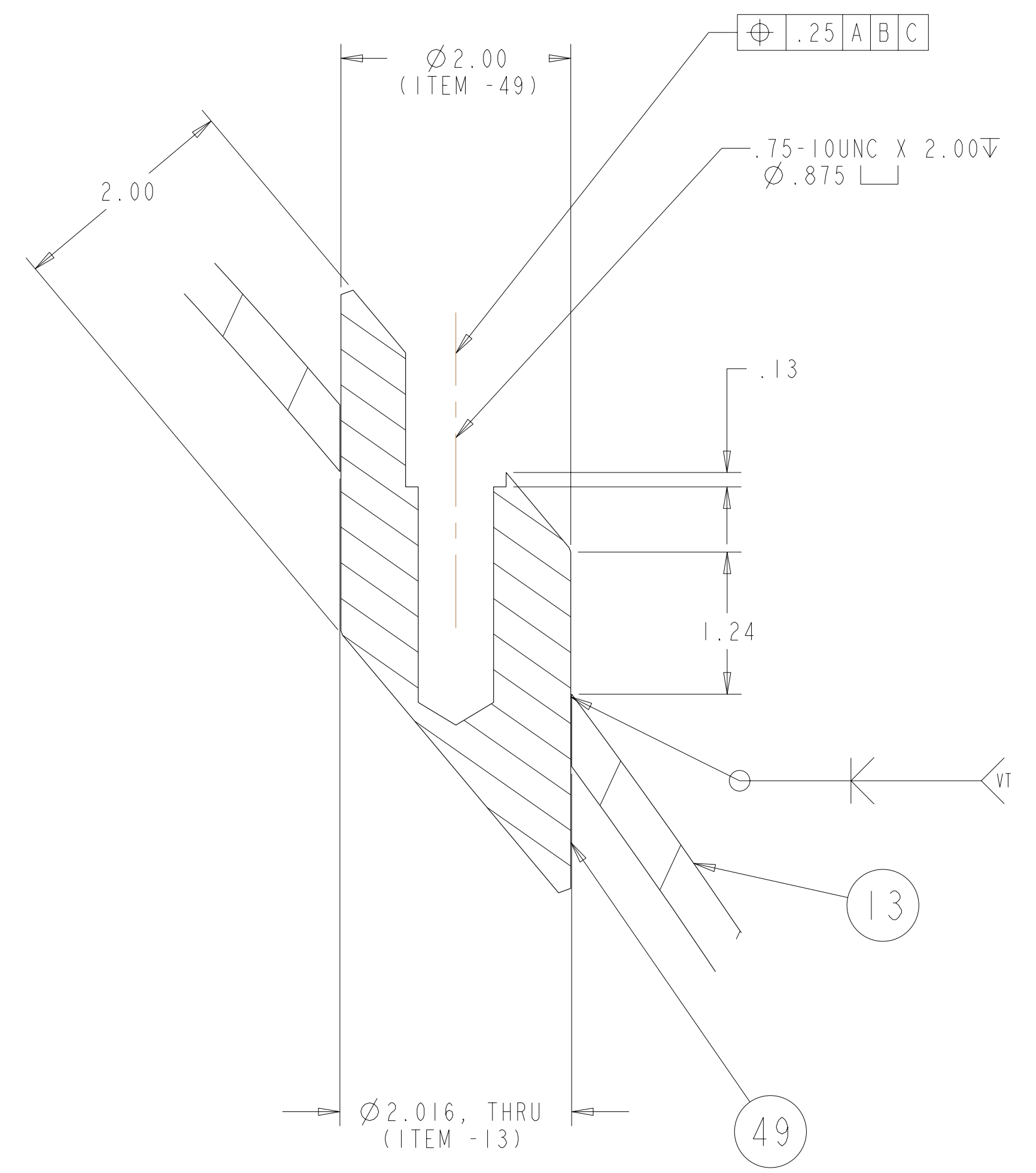

DETAIL Y  
SCALE 1.00

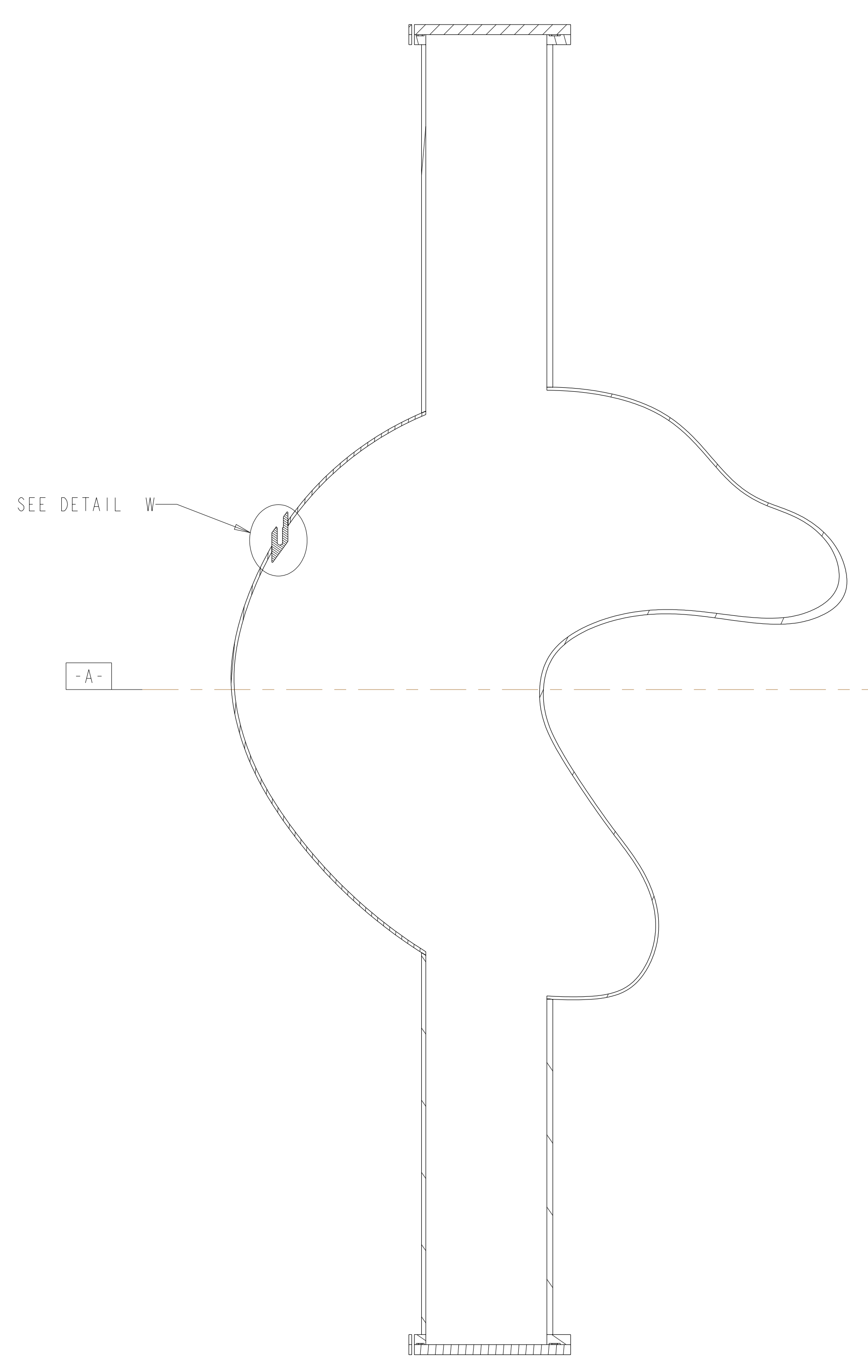

SECTION M-M  
SCALE 0.09

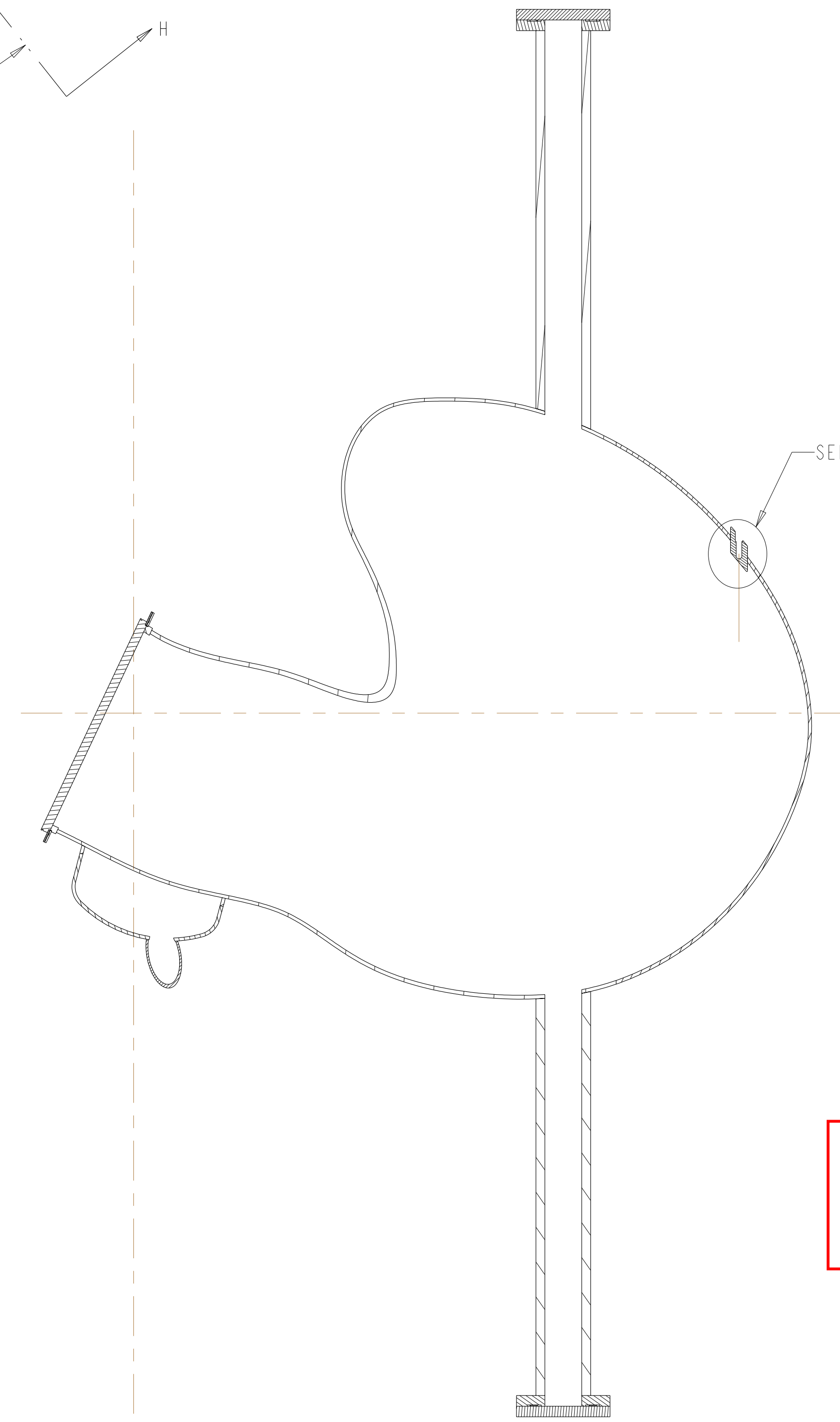

SECTION H-H  
SCALE 0.09

**RELEASED FOR  
FABRICATION / INSTALLATION**  
PPPL Drafting:

UT-BATTELLE							Oak Ridge National Laboratory managed for the DEPARTMENT OF ENERGY under U.S. GOVERNMENT contract DE-AC05-00OR22725 UT-BATTELLE, LLC, Oak Ridge, Tennessee			
NATIONAL COMPACT STELLARATOR EXPERIMENT							PROJECT NAME			
VACUUM VESSEL PERIOD INSPECTION AND LEAK CHECK ASSEMBLY							CLASS			
VERSION NO. 5	PLANT X-10	BLDG 5700	FL 3	SHT OF 19	TYPE A	CLASS U	REV 2		U	
RELEASE LEVEL Fabrication							SEI20-004		1	

H  
G  
F  
E  
D  
C  
B  
A