

.625 STD SOC HD
WRENCH OPENING ∇ .63
TYP EACH END

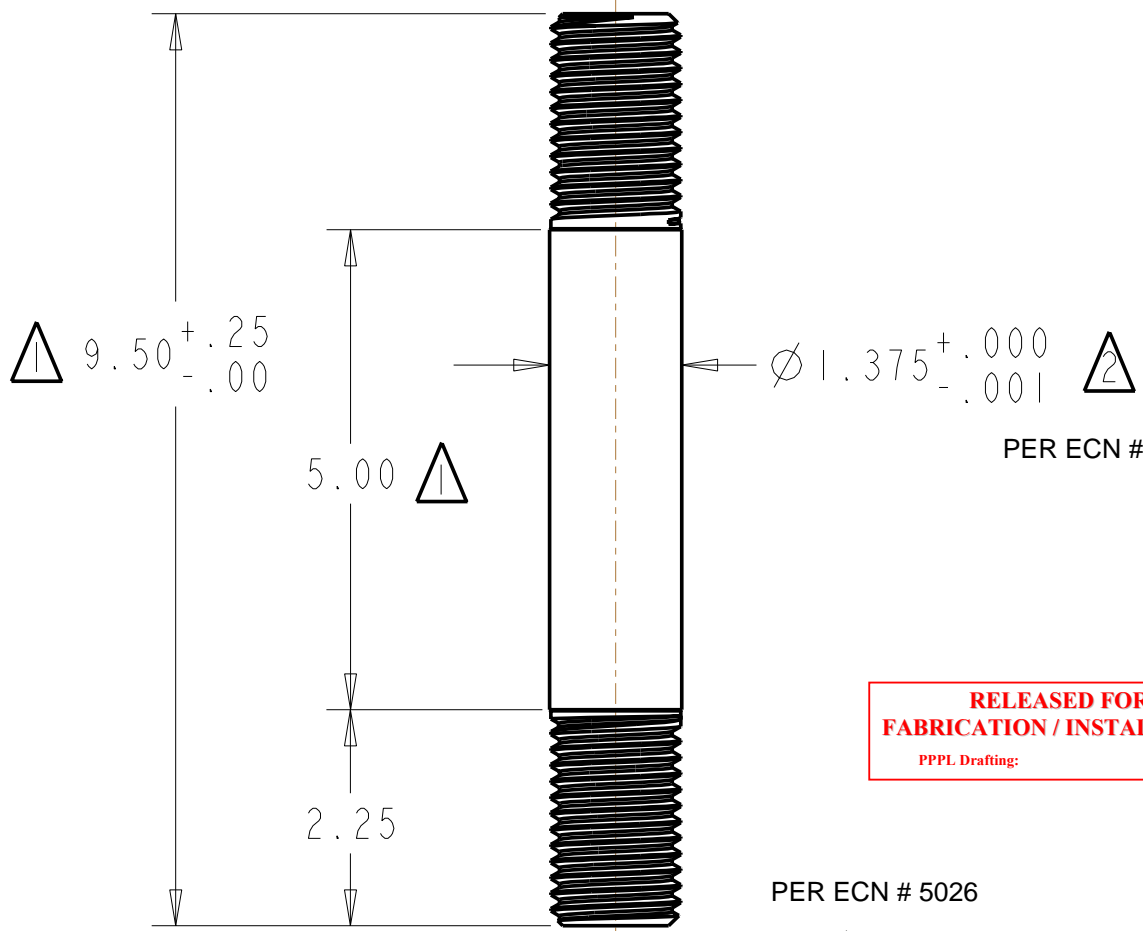

PER ECN # 5026

**RELEASED FOR
FABRICATION / INSTALLATION**
PPPL Drafting:

PER ECN # 5026

2X 1-3/8-6 UNC-2A

$\triangle 2$ MATERIAL CHANGED
DIAM TOL INCREASED

$\triangle 1$ LENGTH INCREASED TO
MATCH AS-BUILT CONFIG

TOLERANCE = $\pm .010$ AND $\pm 2^\circ$

MATERIAL	UNS S66286	SOURCE	BID / PREFERRED
SPEC	ASTM A453 GRADE 660B	VENDOR	COMPANY ADDRESS PHONE
HEAT TREAT	NA		
COATING	SILVER PLATE PER AMS 2410		
UNITS	INCHES		

DATA SHEET

UT-BATTELLE
OAK RIDGE NATIONAL LABORATORY

FILENAME DS141-036	TITLE / DESCRIPTION STUD, 1.375-6UNC-2A X 9.5 LG				
PREPARED BY MT BROWN	CHECKED BY M COLE	APPROVED BY D WILLIAMSON	ISSUE DATE 6/24/04	VER 0	REV 2