

FOR NOTES AND PARTS LIST SEE SHEET 1

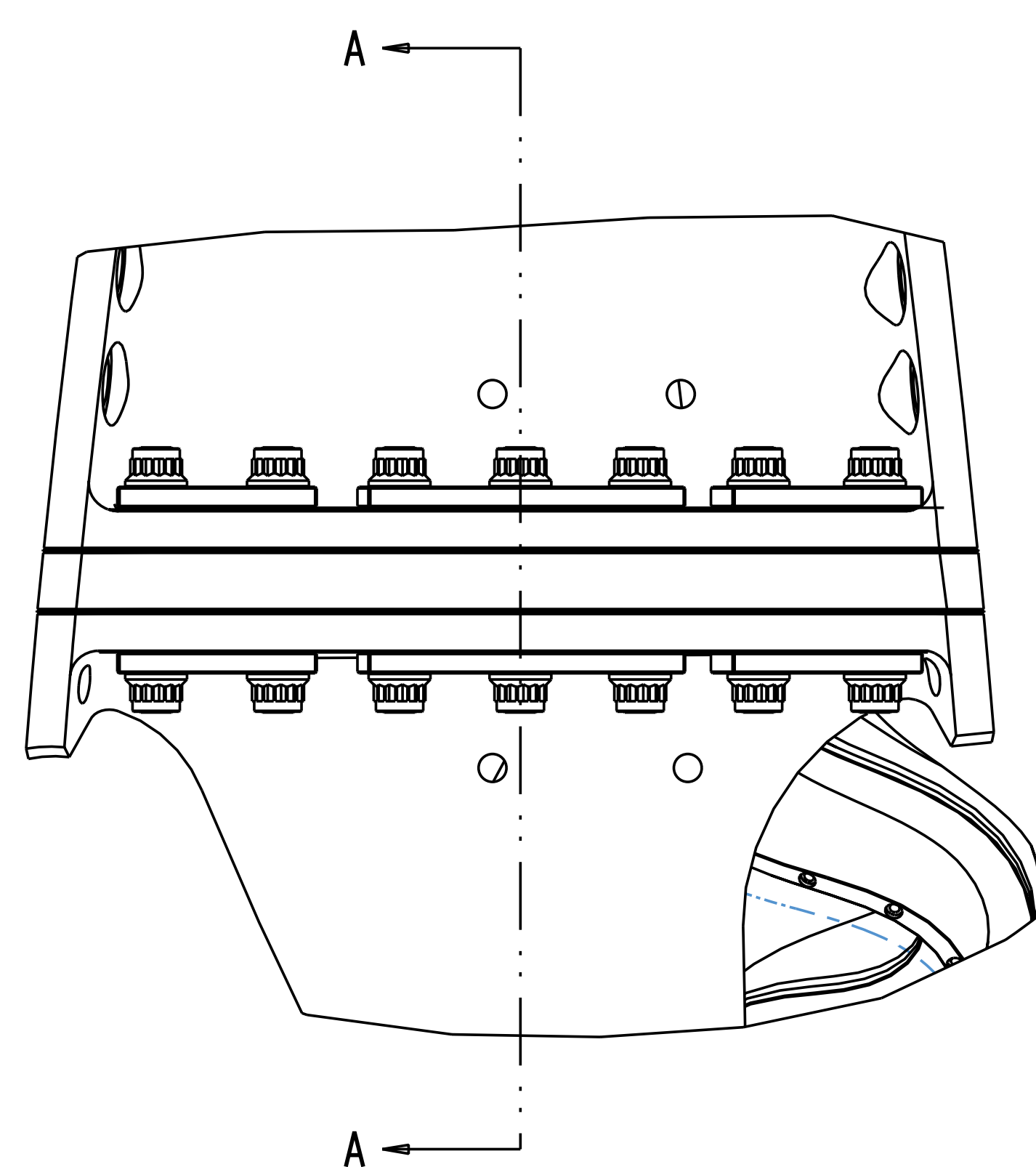

SEE DETAIL X

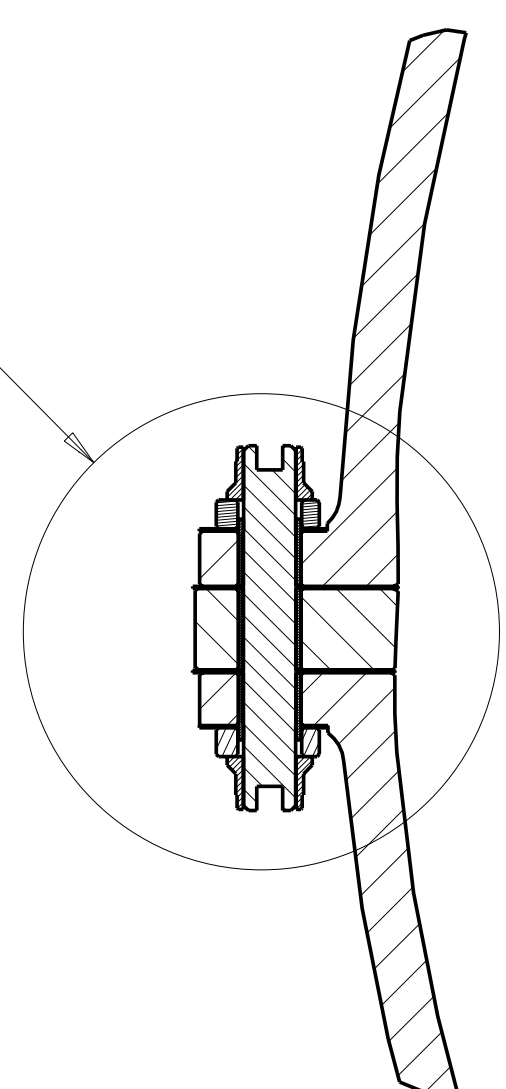

SECTION A-A
SCALE 0.20

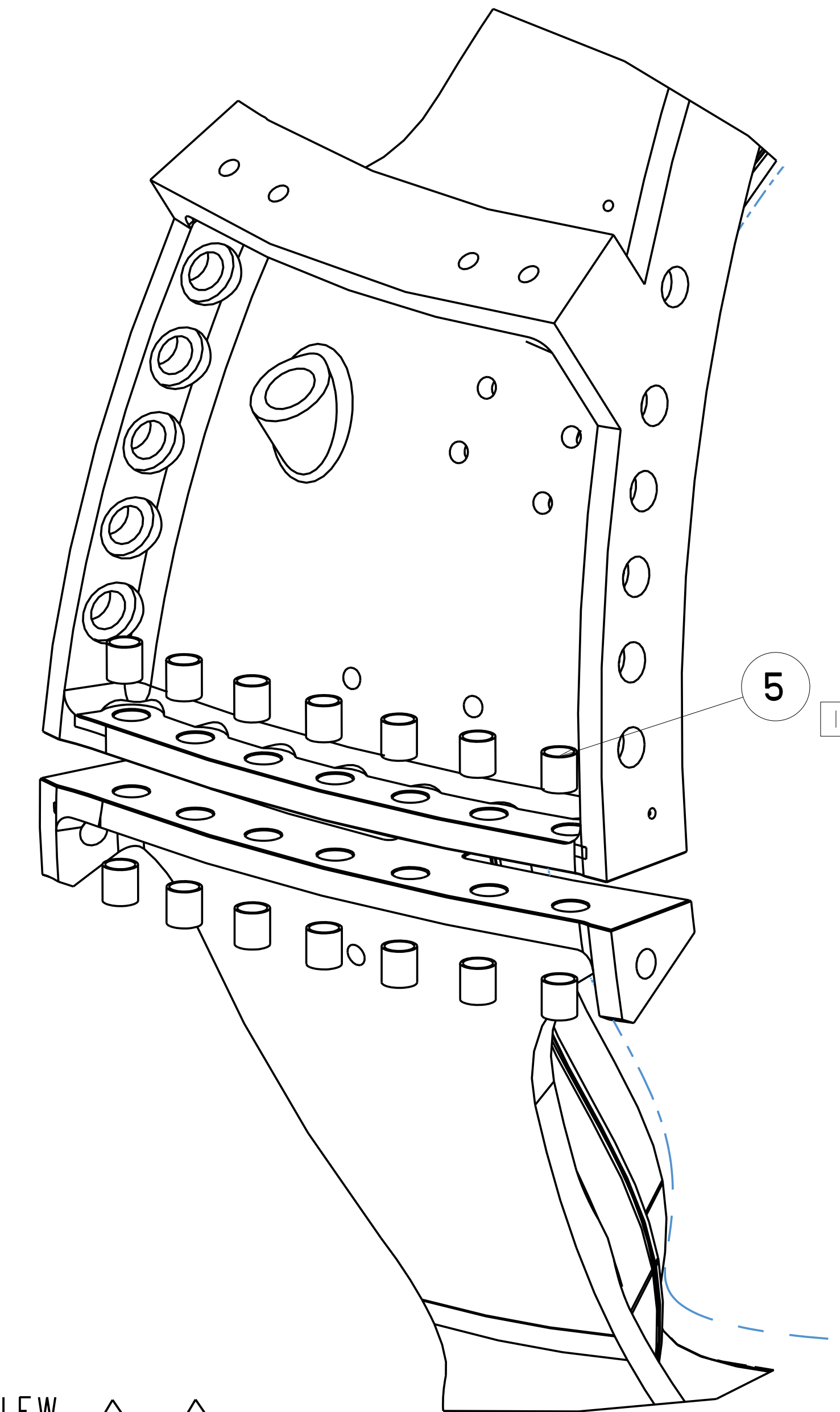
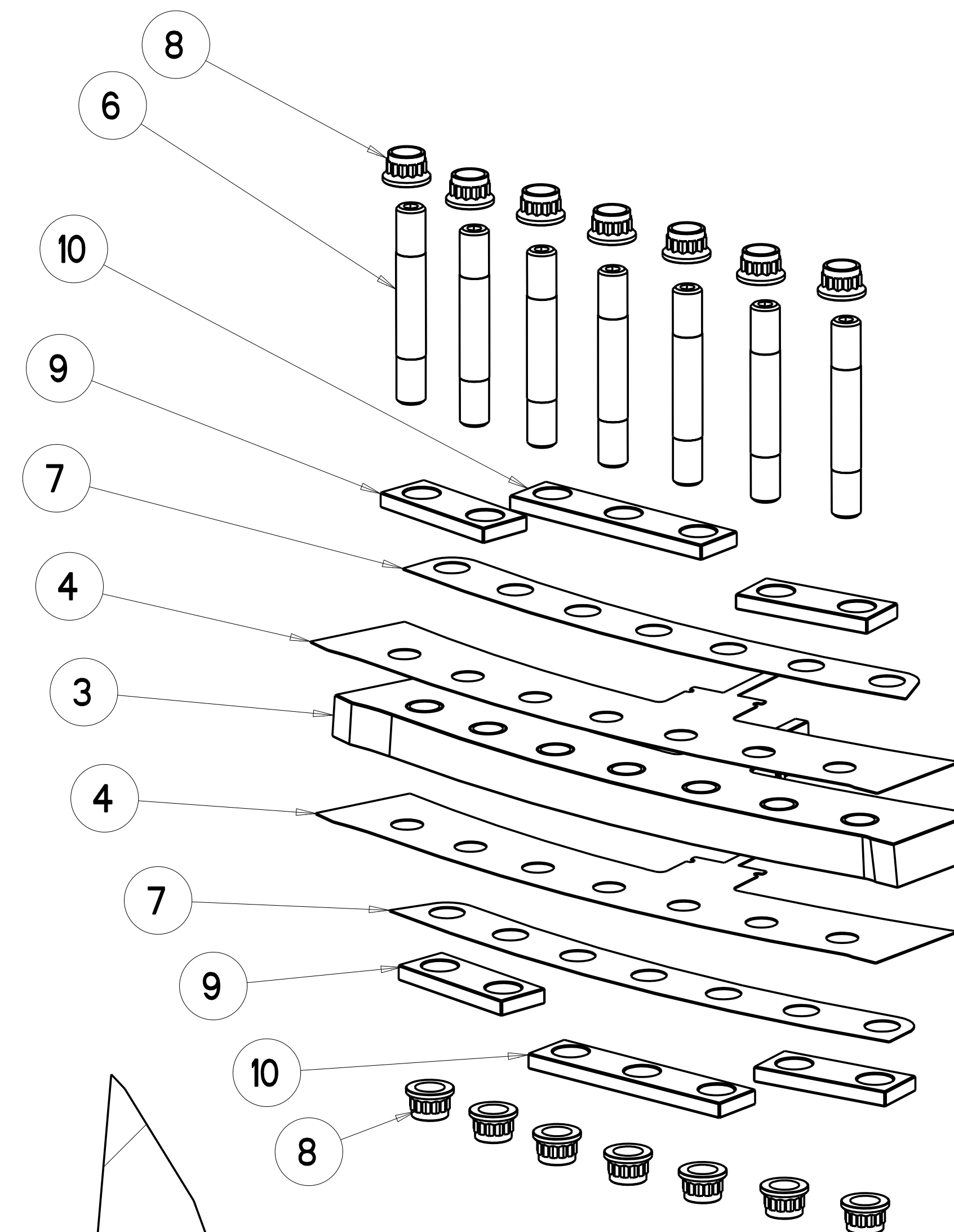

1 EXPLODED VIEW
SCALE 0.20

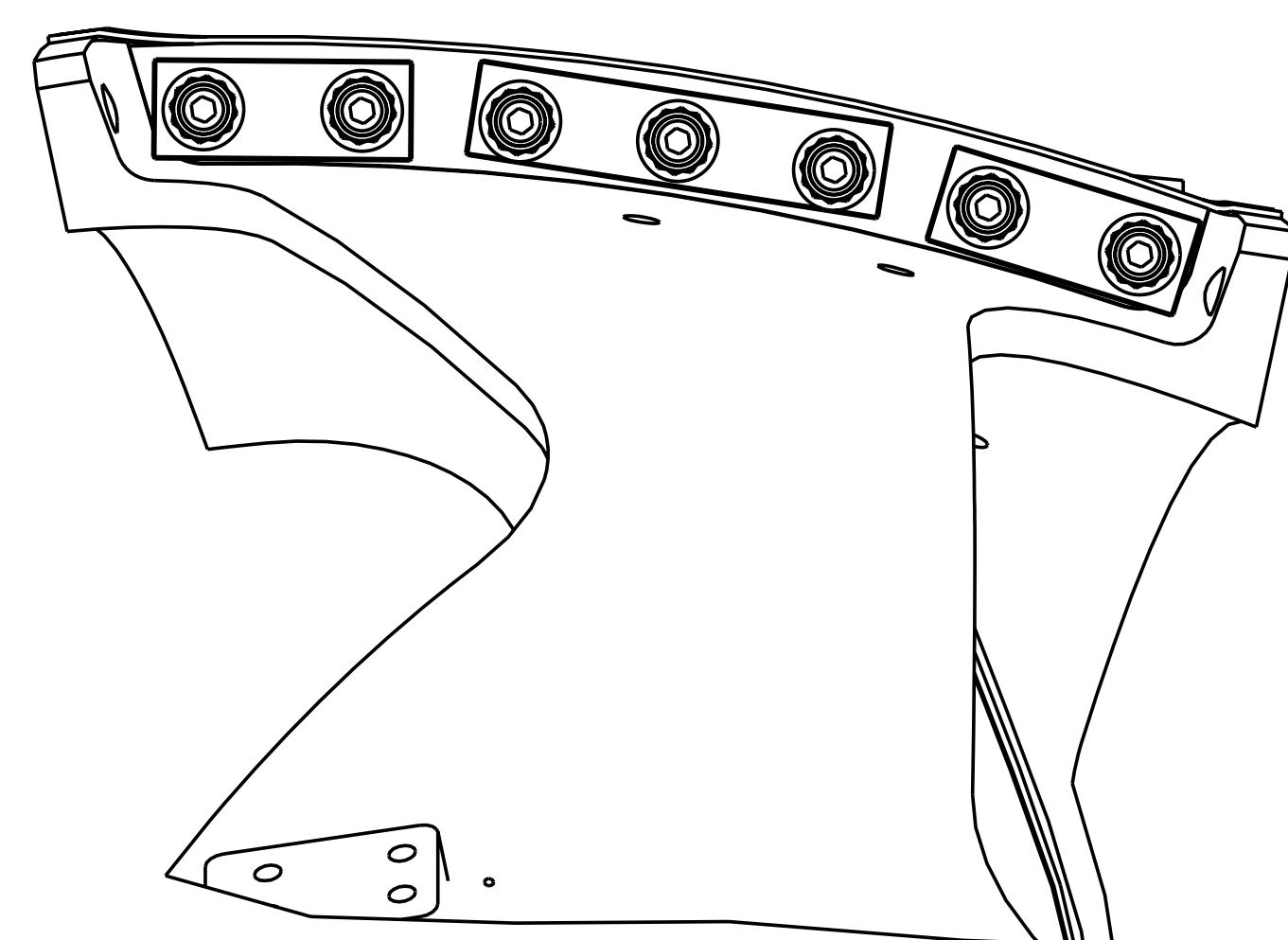
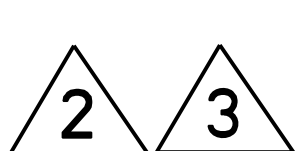

POLOIDAL BREAK DETAIL

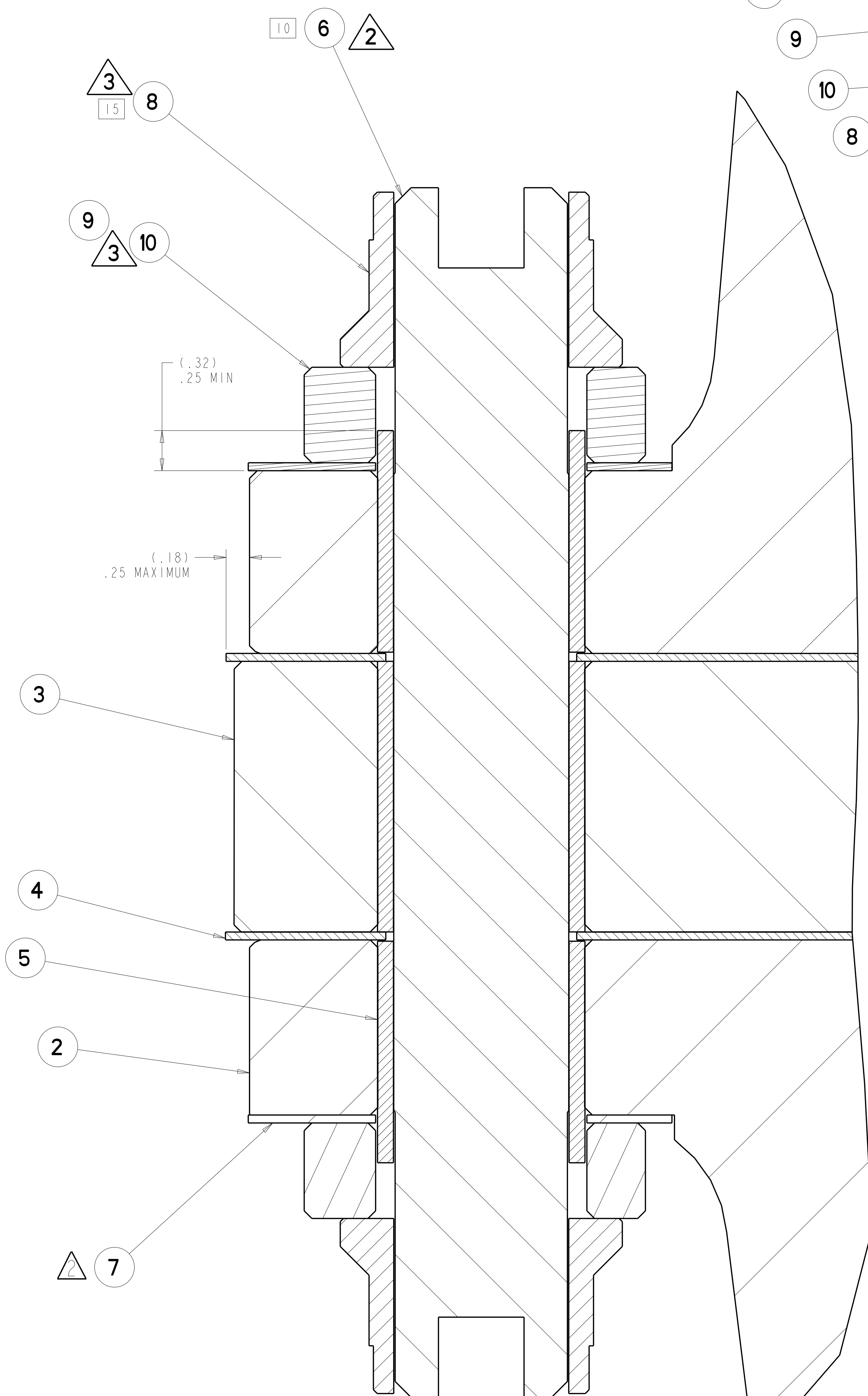

DETAIL X
SCALE 2.00

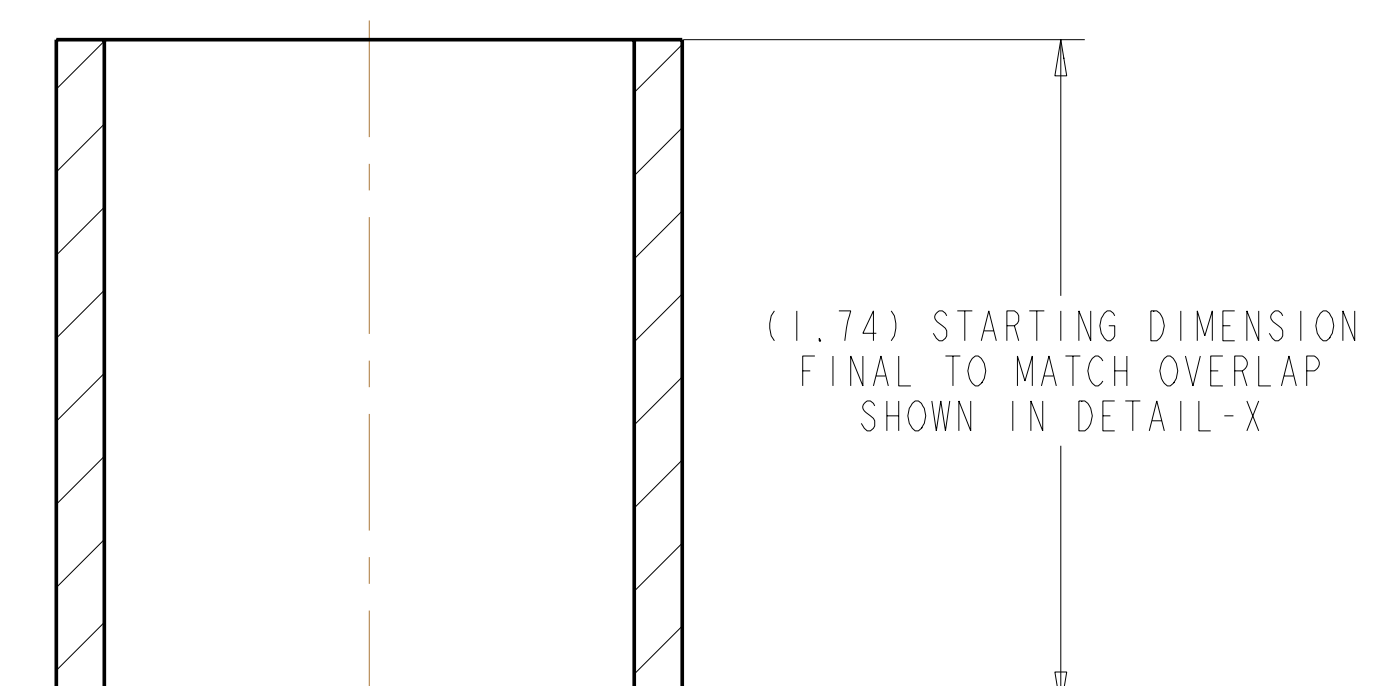
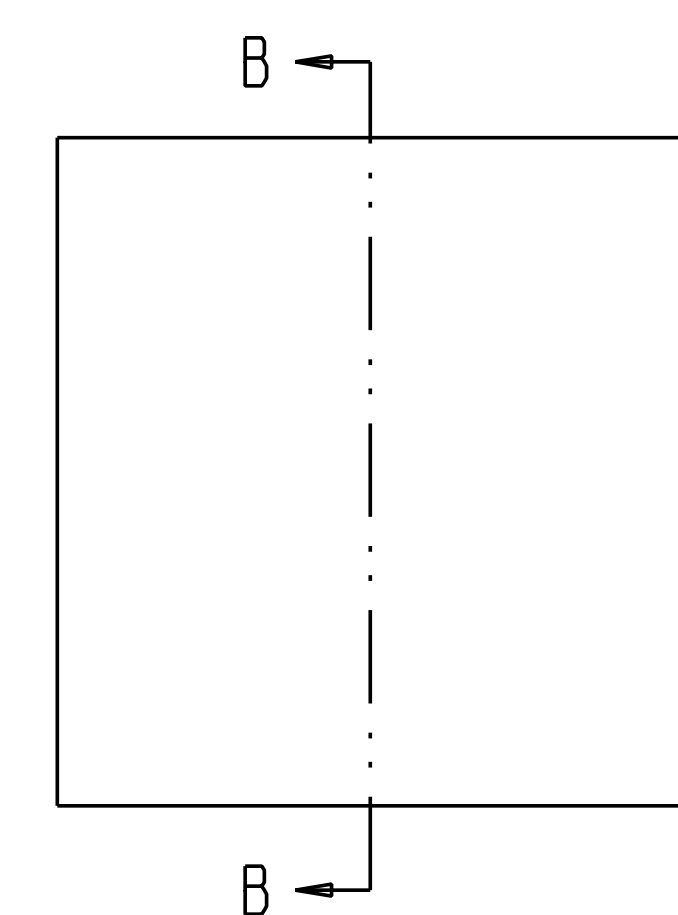
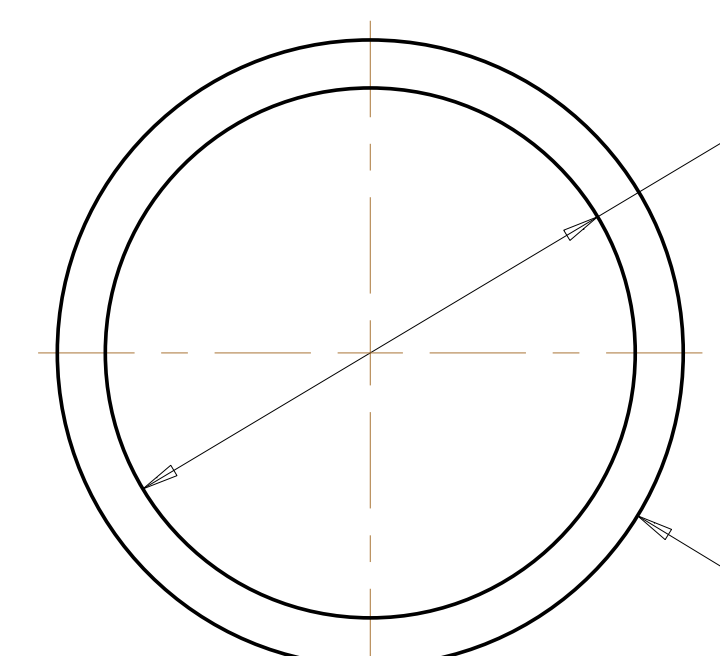

5 SECTION B-B
SCALE 2.00

**RELEASED FOR
FABRICATION / INSTALLATION**

PPPL Drafting:

Oak Ridge National Laboratory managed for the DEPARTMENT OF ENERGY under U.S. GOVERNMENT contract DE-AC05-00OR22725 UT-BATTELLE, LLC, Oak Ridge, Tennessee PROJECT NAME:							
UT-BATTELLE NATIONAL COMPACT STELLARATOR EXPERIMENT							
MOD COIL WINDING FORM ASSEMBLY TYPE-A							
VERSION NO.	PLANT	BLDG	FL	SHT OF	TYPE	CLASS	
3	X-10	5700	3	2	S	U	
RELEASE LEVEL	SEI41-101						REV
Fabrication							3

SEI41-101

A