

ISOMETRIC VIEW

NOTES:

1. DRAWING PREPARED IN ACCORDANCE WITH ASME Y14.8M-1996.
2. INTERPRET DIMENSIONS AND TOLERANCES PER ANSI Y14.5M-1994.
3. DIMENSIONS ARE IN INCHES.
4. DRAWING DEPICTS FINAL MACHINED STATE OF PART DEFINED BY PRO/ENGINEER FILE SEI41-114.PRT.
5. UNLESS OTHERWISE SPECIFIED, DIMENSIONS ARE RELATED TO DATUM A- (PRIMARY X-Y PLANE, TOP) DATUM B- (SECONDARY Y-Z PLANE, SIDE) DATUM C- (TERTIARY X-Z PLANE, FRONT)
6. DIMENSIONS APPLY AT TEMPERATURE OF 20-30°C (68-86°F).
7. DIMENSIONS AND TOLERANCES EXCLUDE PROCESS MATERIAL ALLOWANCES WHICH MAY ADD MASS.
8. APPROXIMATE WEIGHT = 4819 LBS. WEIGHT OF FINISHED PART NOT TO EXCEED 6000 LBS.
- 9 UNLESS OTHERWISE SPECIFIED, AS-CAST SURFACE PROFILE TOLERANCE = +/- .25 INCH, WITH EXEMPTION FOR INTERSECTING SURFACES WHERE FILLETS ARE EXPECTED. MIN FILLET AND CORNER RADI = 0.5 +/- 0.1 IN.
- 10 DESIGNATED SURFACE REGIONS HAVE PROFILE TOLERANCE = +/- 0.125 IN.
11. MIN THICKNESS PER CAD GEOMETRY, TOLERANCE = +0.25 IN / -0.0 IN.
12. PARTING LINE EDGES, FLASH, GATES, RUNNER, AND RISER EXTENSIONS 0.25 IN MAX
- 13 UNLESS OTHERWISE SPECIFIED, MACHINED SURFACE PROFILE TOLERANCE = +/- 0.01 IN.
14. BACK SPOTFACE ALL THRU HOLES MINIMUM TO CLEAN UP.
- 15 SEE LATEST REVISION OF SPECIFICATION NCSX-CSPEC-141-03 FOR ADDITIONAL REQUIREMENTS.

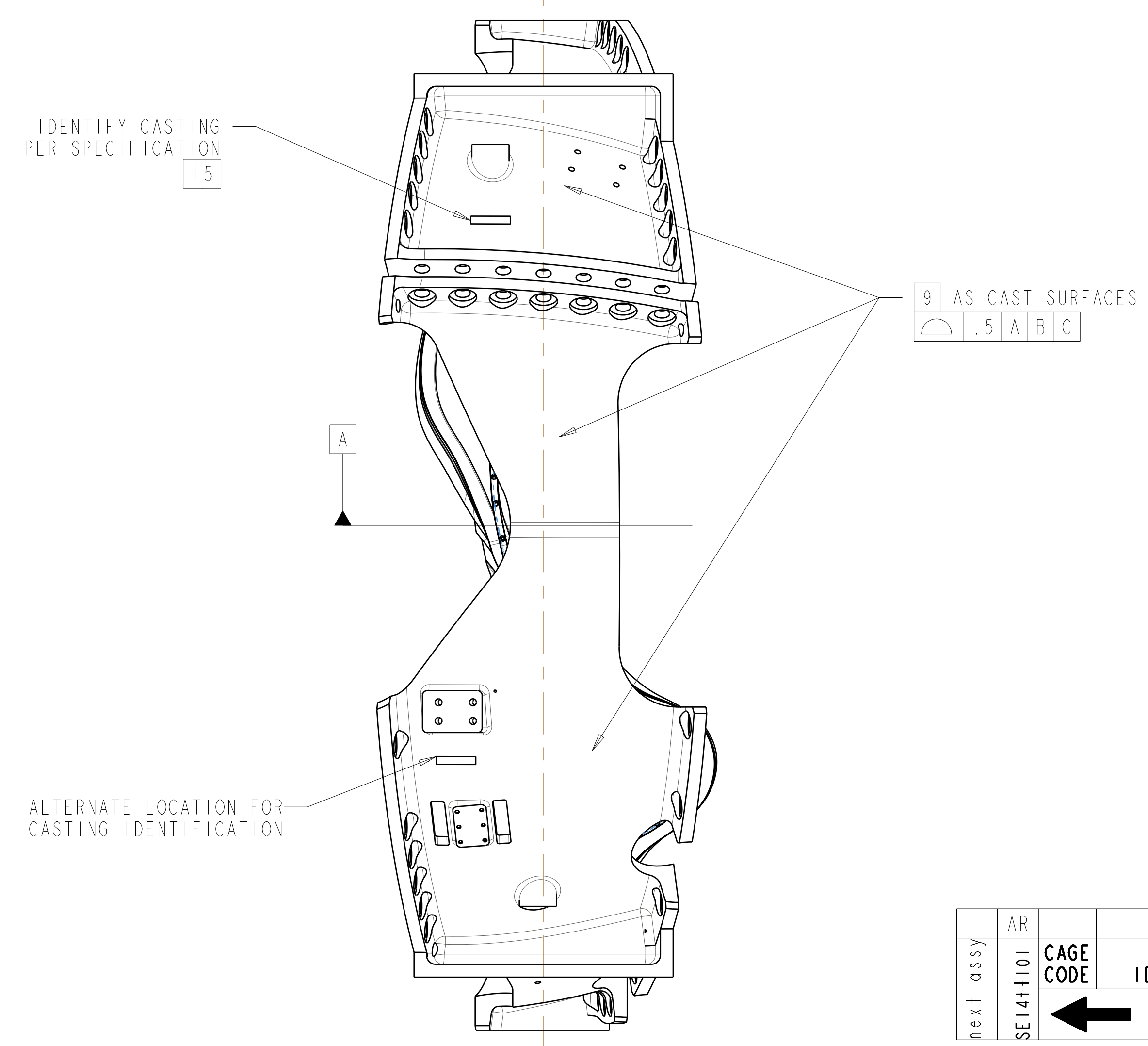
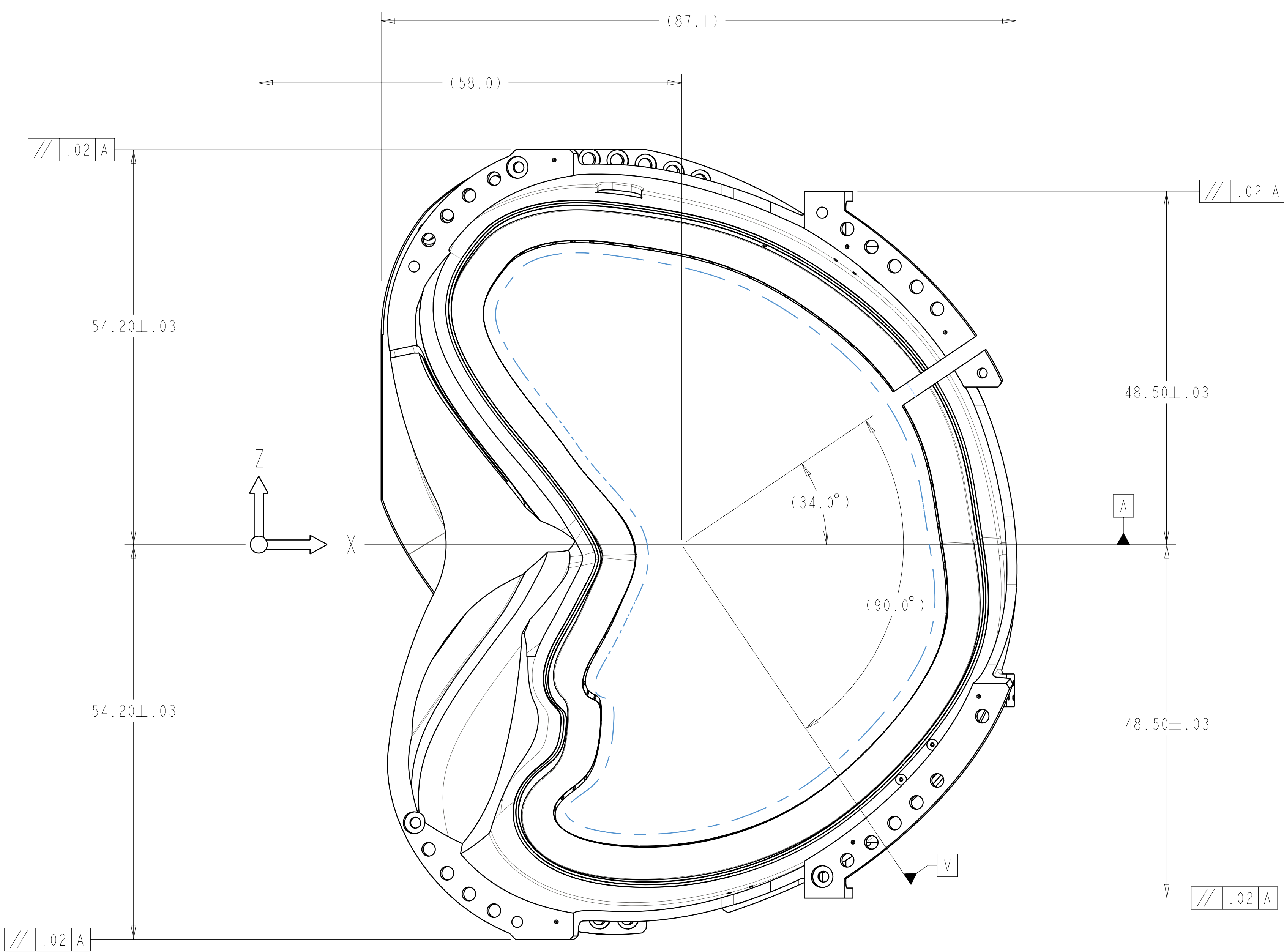

RELEASED FOR FABRICATION / INSTALLATION
 PPPL Drafting:

REV	DESCRIPTION	BY	DATE	CHK	DEPT	DATE	PE	REQ	DATE	ORNL	DOE	DATE
1	REMOVED SPHERICAL SEATS, REVISED LEAD BLOCK/COOLING PER ECN-4903	GL	9/04	MJC	DEW							
2	REVISED PART AND DRAWING PER ECN 4944	GL	3-05	MJC	DEW							
3	REVISED PART AND DRAWING PER ECN 4965	GL	1/05	MJC	DEW							

SCALE NOTED	DES T BROWN 06-01-04	DRW P MILLER 06-02-04	CHK M COLE 7/22/04	SECT :	DEPT :	PE D WILLIAMSON 7/22/04	PJ :	REG :	PPPL DRFT J SIEGEL 7/22/04	VERSION NO. 9	PLANT X-10	BLDG 5700	FL 3	SHT OF 11	TYPE S	CLASS U
TOLERANCES UNLESS OTHERWISE SPECIFIED	UT-BATTELLE U.S. GOVERNMENT contract DE-AC05-00OR22725 UT-BATTELLE, LLC Oak Ridge, Tennessee			NATIONAL COMPACT STELLARATOR EXPERIMENT												
FRACTIONS ±.01	PRODUCTION WINDING FORM TYPE-A															
XXX DECIMALS ±.005	RELEASE LEVEL SEI41-114															
ANGLES ±0°15'	Fabrication															
BREAK SHARP EDGES .06 MAX	REV 3															
FINISH .125 UNLESS OTHERWISE SPECIFIED	DRAWING APPROVALS DATE															

P THIS DRAWING PRODUCED ON PRO-ENGINEER

NO REPRESENTATION OR WARRANTY, EXPRESSED OR IMPLIED, IS MADE AS TO THE ACCURACY, COMPLETENESS OR USEFULNESS OF THE INFORMATION OR STATEMENTS CONTAINED IN THESE DRAWINGS, OR THAT THE USE OR DISCLOSURE OF ANY INFORMATION, APPARATUS, METHOD OR PROCESS DISCLOSED IN THESE DRAWINGS MAY NOT INFRINGE PRIVATE RIGHTS OF OTHERS. NO LIABILITY IS ASSUMED WITH RESPECT TO THE USE OF, OR FOR DAMAGES RESULTING FROM THE USE OF, ANY INFORMATION, APPARATUS, METHOD OR PROCESS DISCLOSED IN THESE DRAWINGS. DRAWINGS MADE AVAILABLE FOR INFORMATION TO BIDDER ARE NOT TO BE USED FOR OTHER PURPOSES, AND ARE TO BE RETURNED UPON REQUEST OF THE FORWARDING CONTRACTOR.

H
G
F
E
D
C
B
A

FOR NOTES AND PARTS LIST SEE SHEET 1

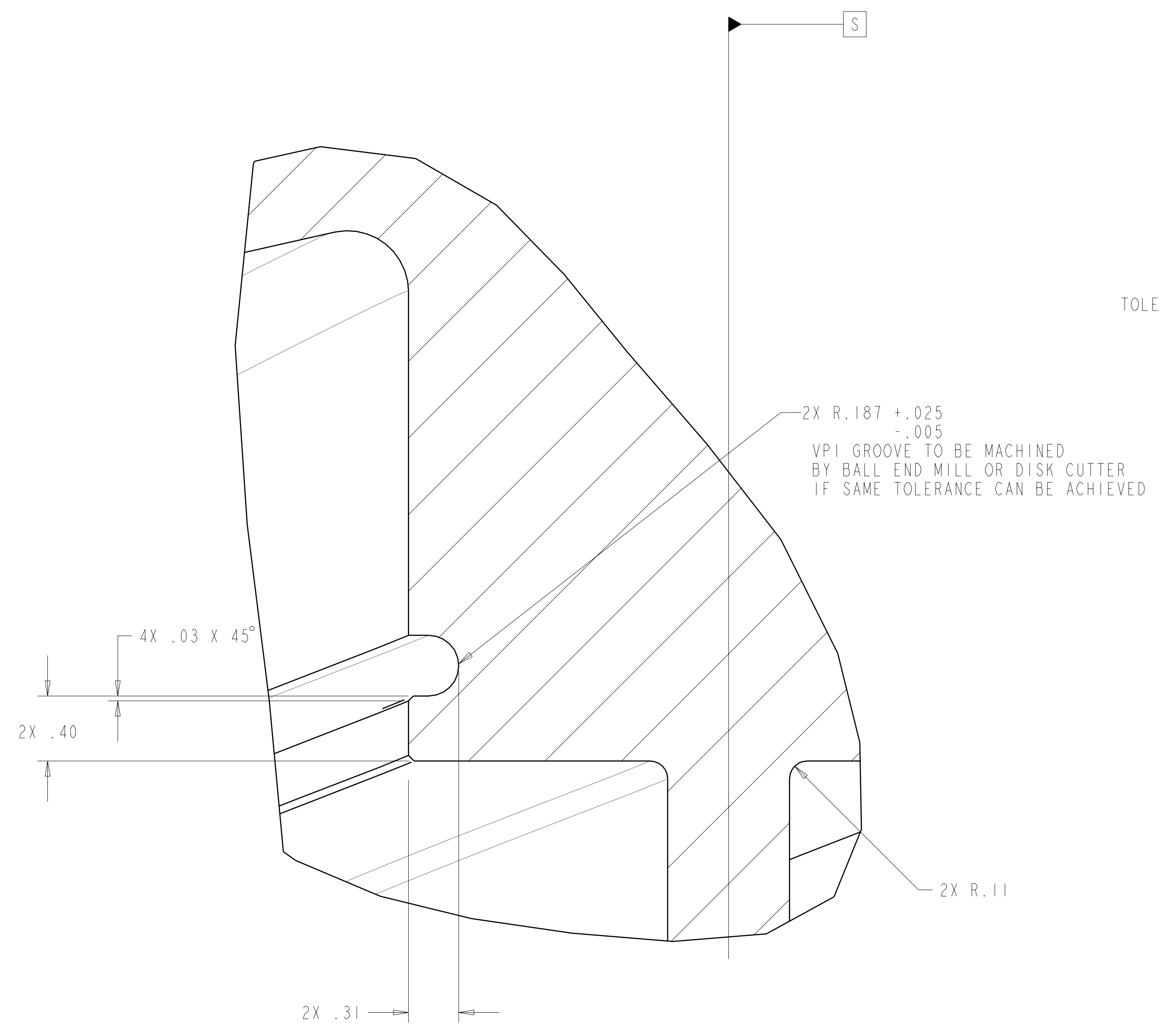

DETAIL B
SCALE 2.00

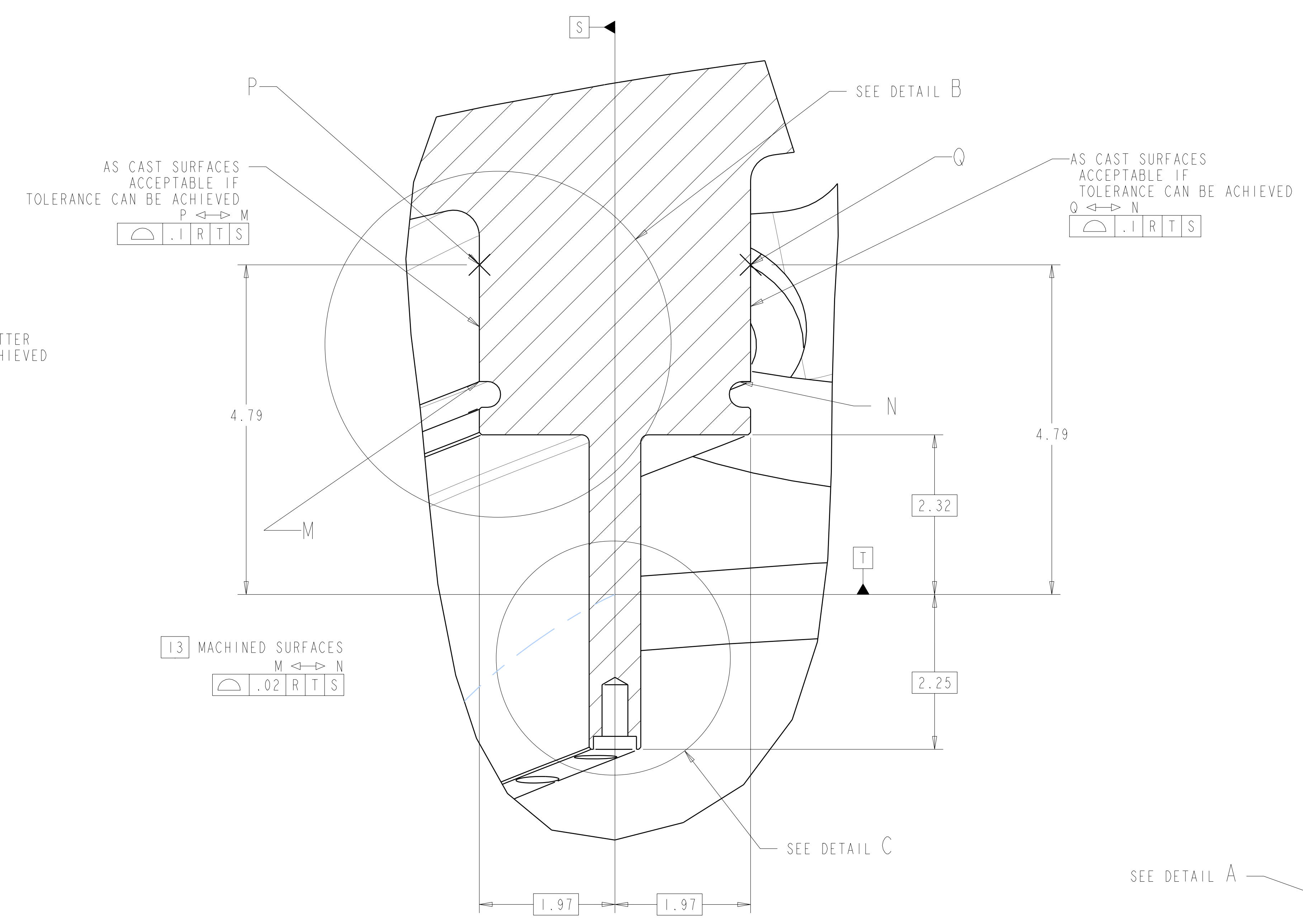

DETAIL A
SCALE 1.00

TYPICAL FOR ALL POINTS ALONG WINDING CENTER

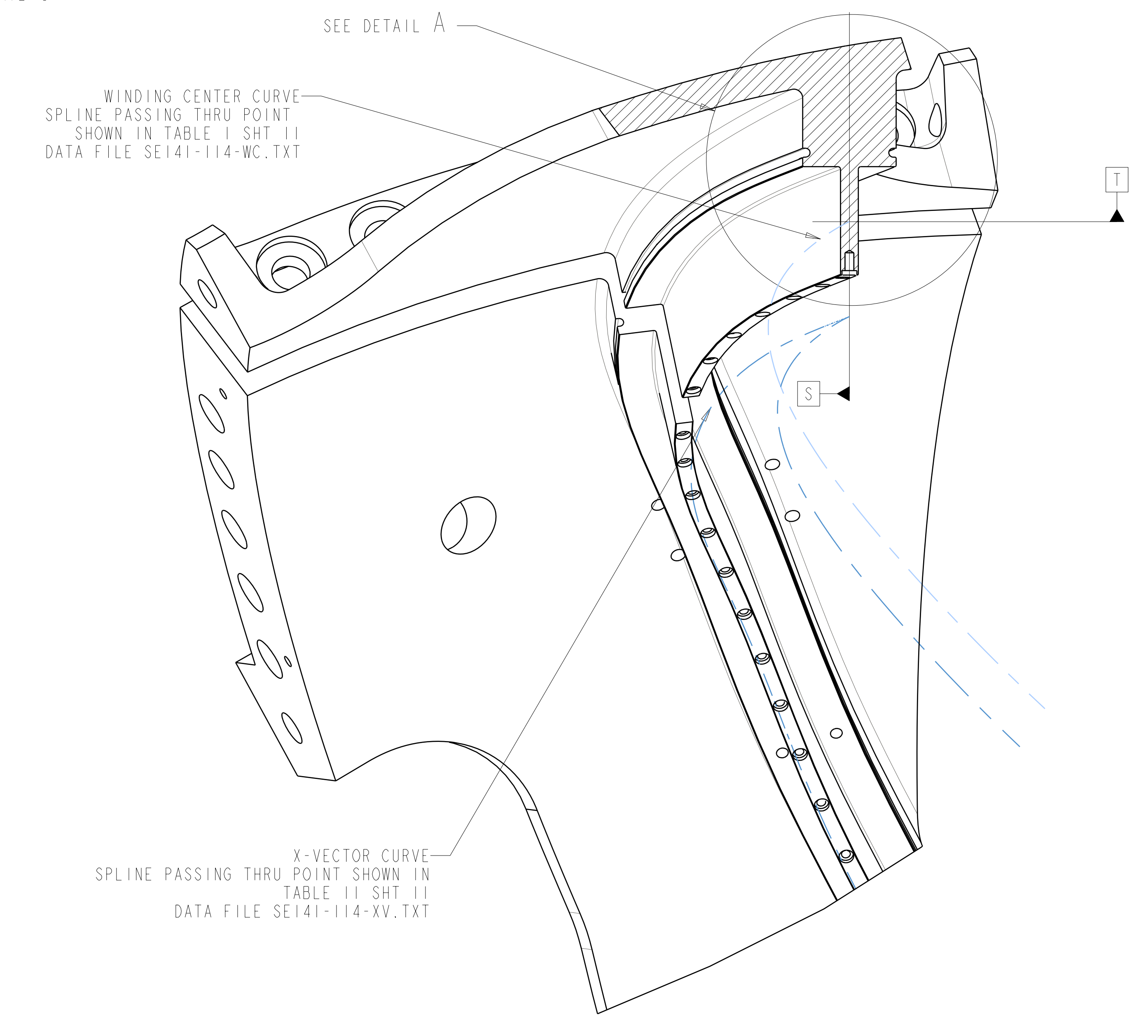

SECTION R-R
SCALE 0.30

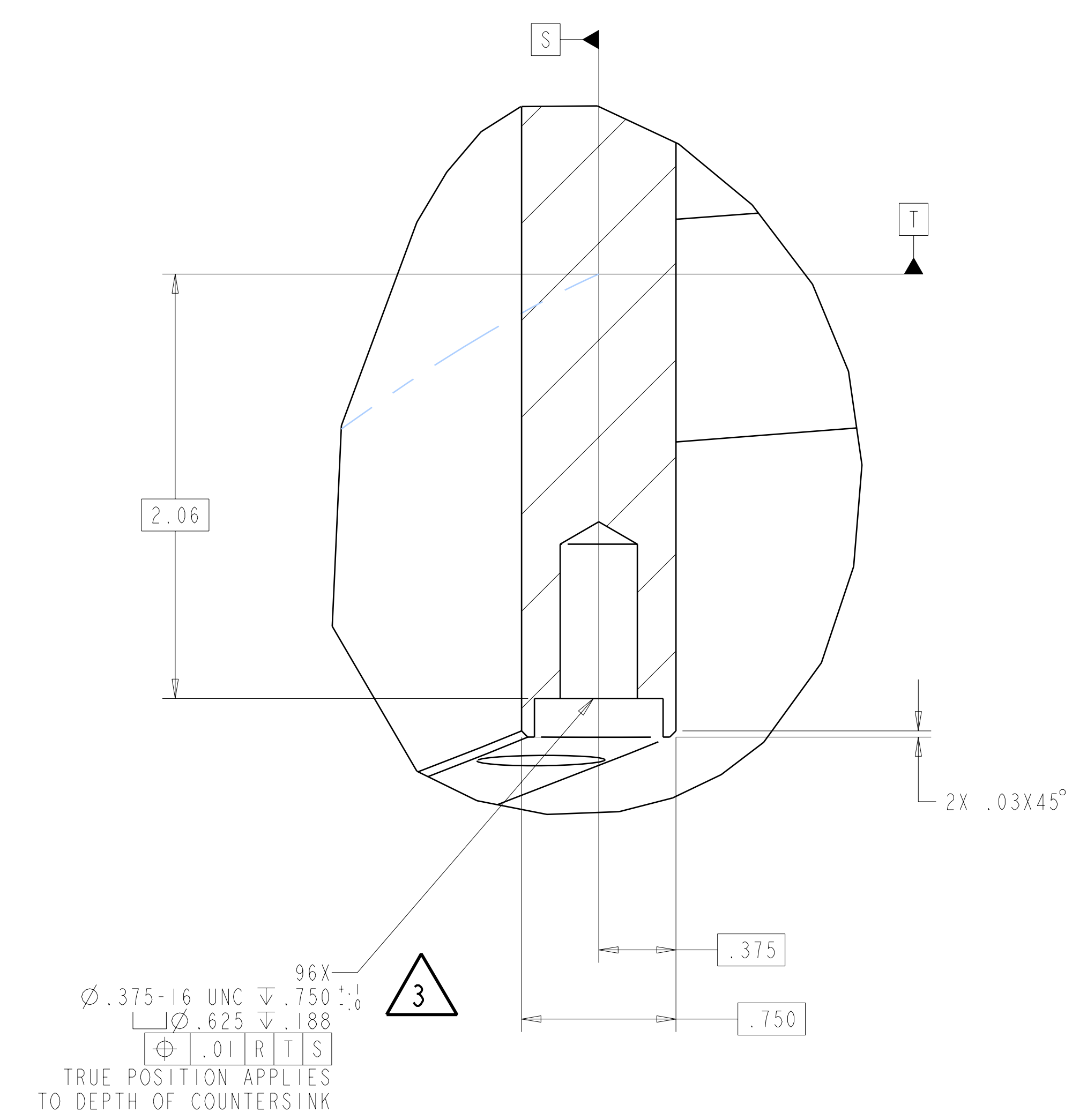
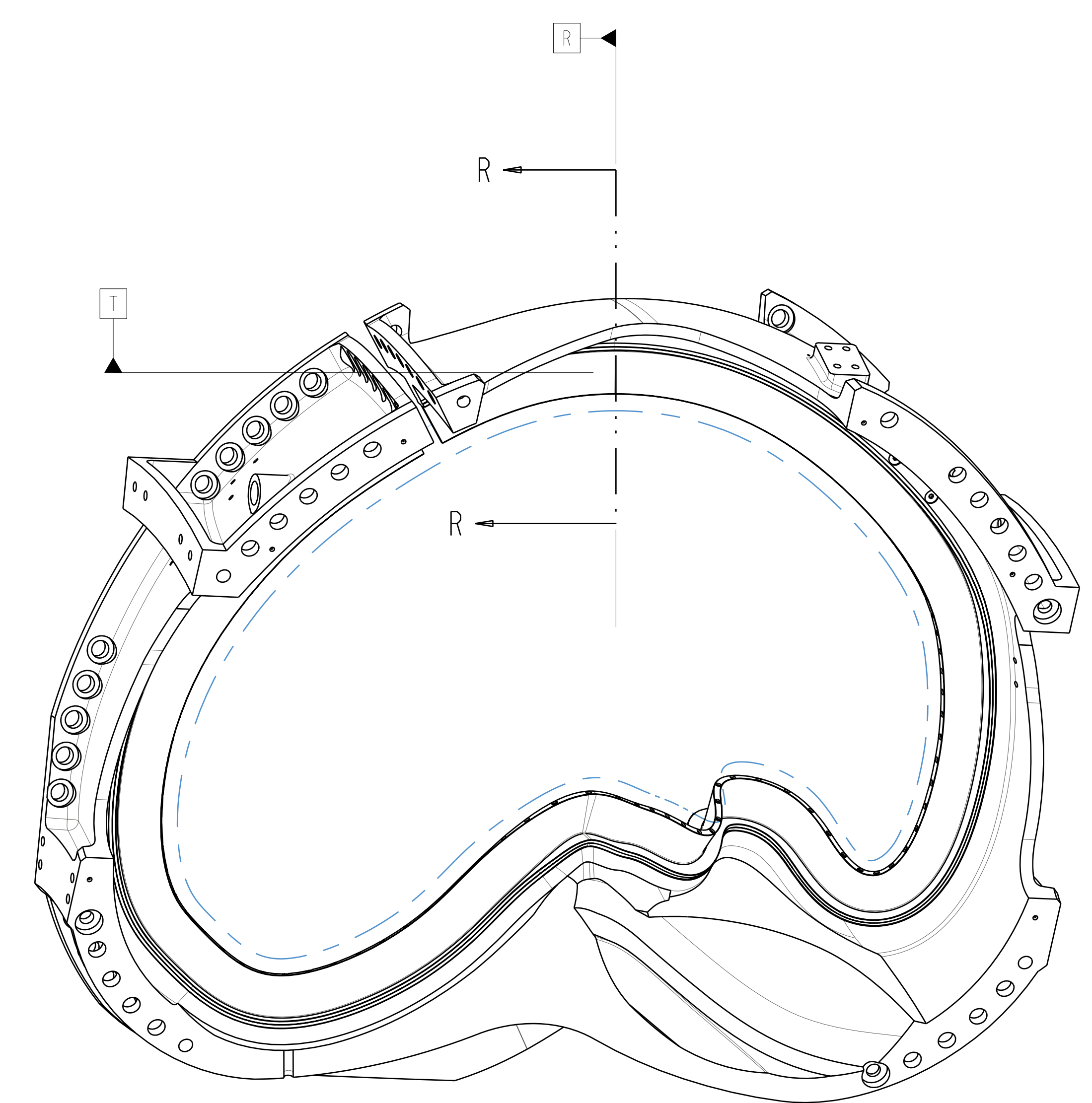

DETAIL C
SCALE 2.00

**RELEASED FOR
FABRICATION / INSTALLATION**

PPPL Drafting:

DATUM R = PLANE NORMAL TO WINDING CENTER
DATUM S = PLANE PASSING THRU WINDING CENTER AND X VECTOR AT DATUM R
DATUM T = PLANE PASSING THRU WINDING CENTER ORTHOGONAL TO DATUM S

Oak Ridge National Laboratory managed for the DEPARTMENT OF ENERGY under U.S. GOVERNMENT CONTRACT DE-AC05-00OR22725 UT-BATTELLE, LLC. Oak Ridge, Tennessee PROJECT NAME							
UT-BATTELLE NATIONAL COMPACT STELLARATOR EXPERIMENT PRODUCTION WINDING FORM TYPE-A							
VERSION NO.	PLANT	BLDG	FL	SHT OF	TYPE	CLASS	
9	X-10	5700	3	2	11	S	U
RELEASE LEVEL	SE141-114						REV
Fabrication							3

FOR NOTES AND PARTS LIST SEE SHEET 1

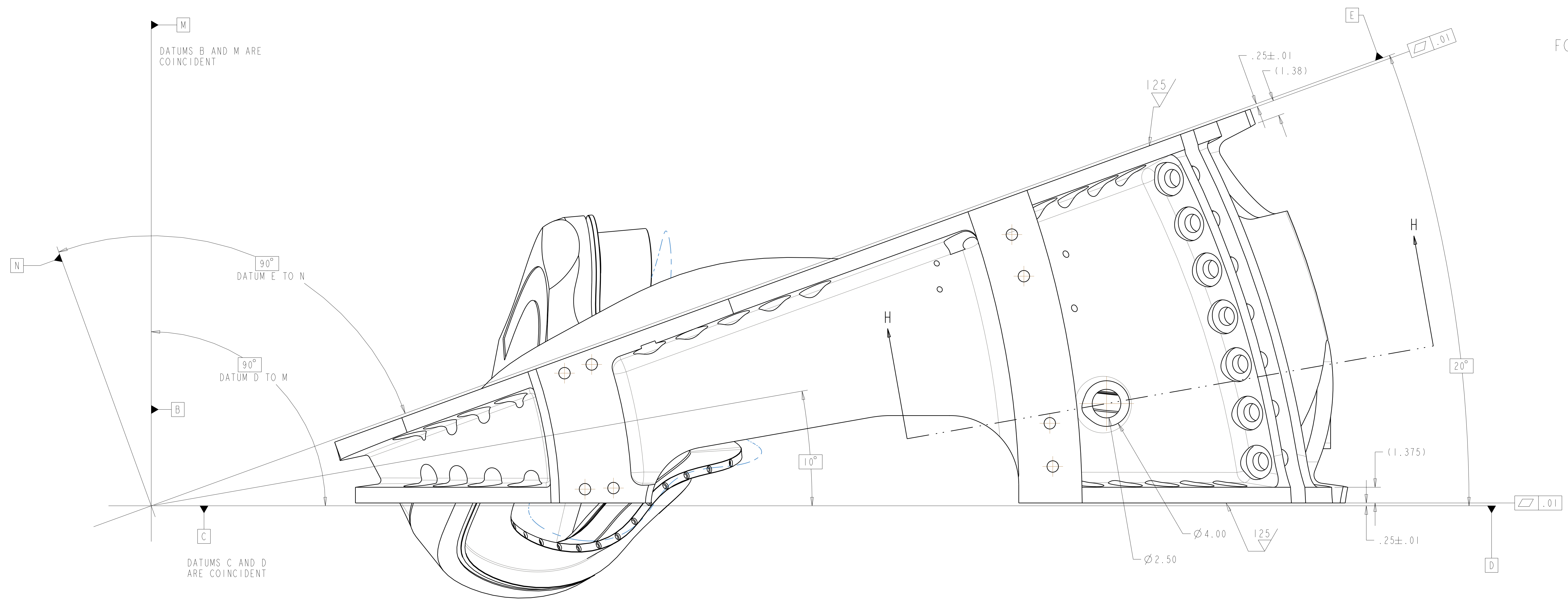

TOP VIEW
SCALE 0.25

DATUMS A B & C ARE MACHINE SPECIFIC.
ALL OTHER DATUMS LISTED ON THIS DRAWING
ARE SPECIFIC TO THIS PART

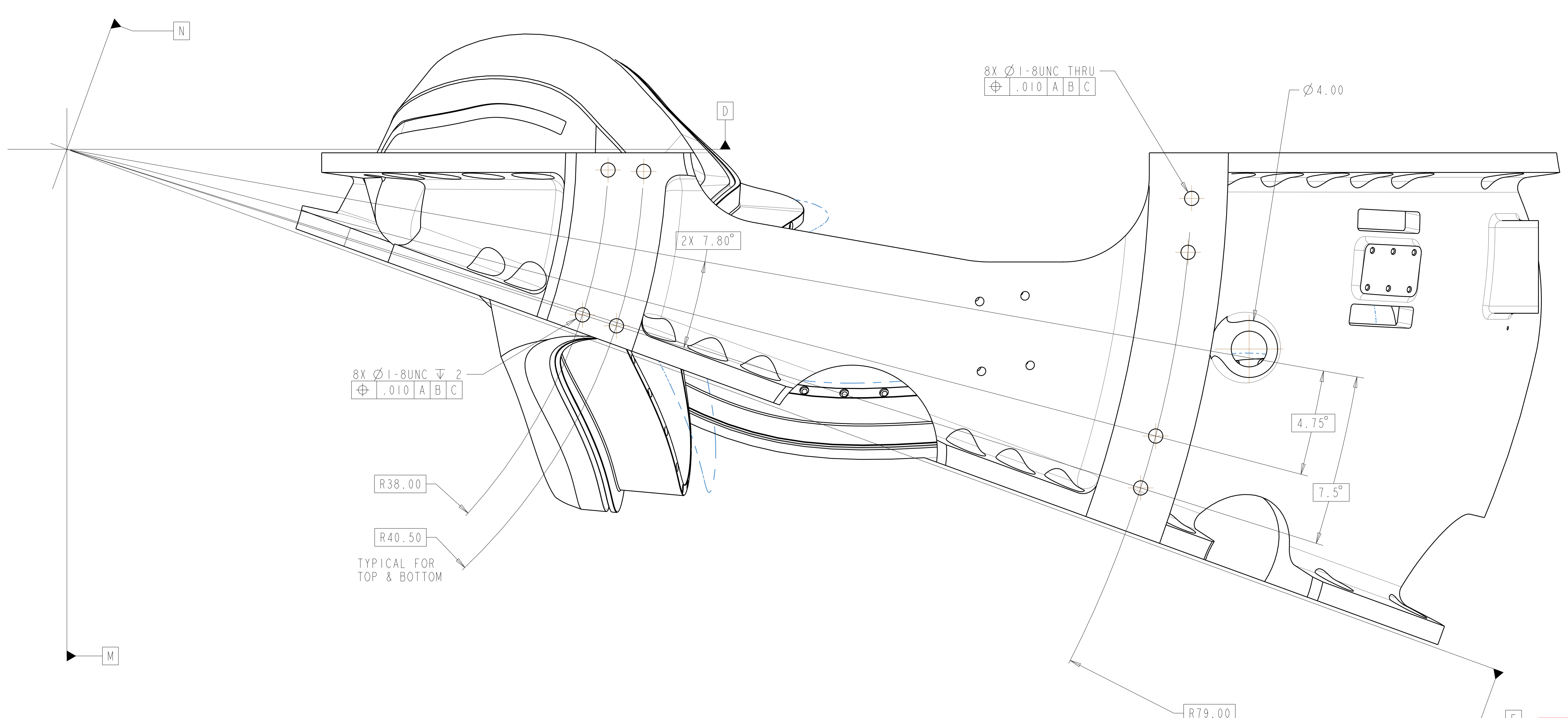

BOTTOM VIEW
SCALE 0.25

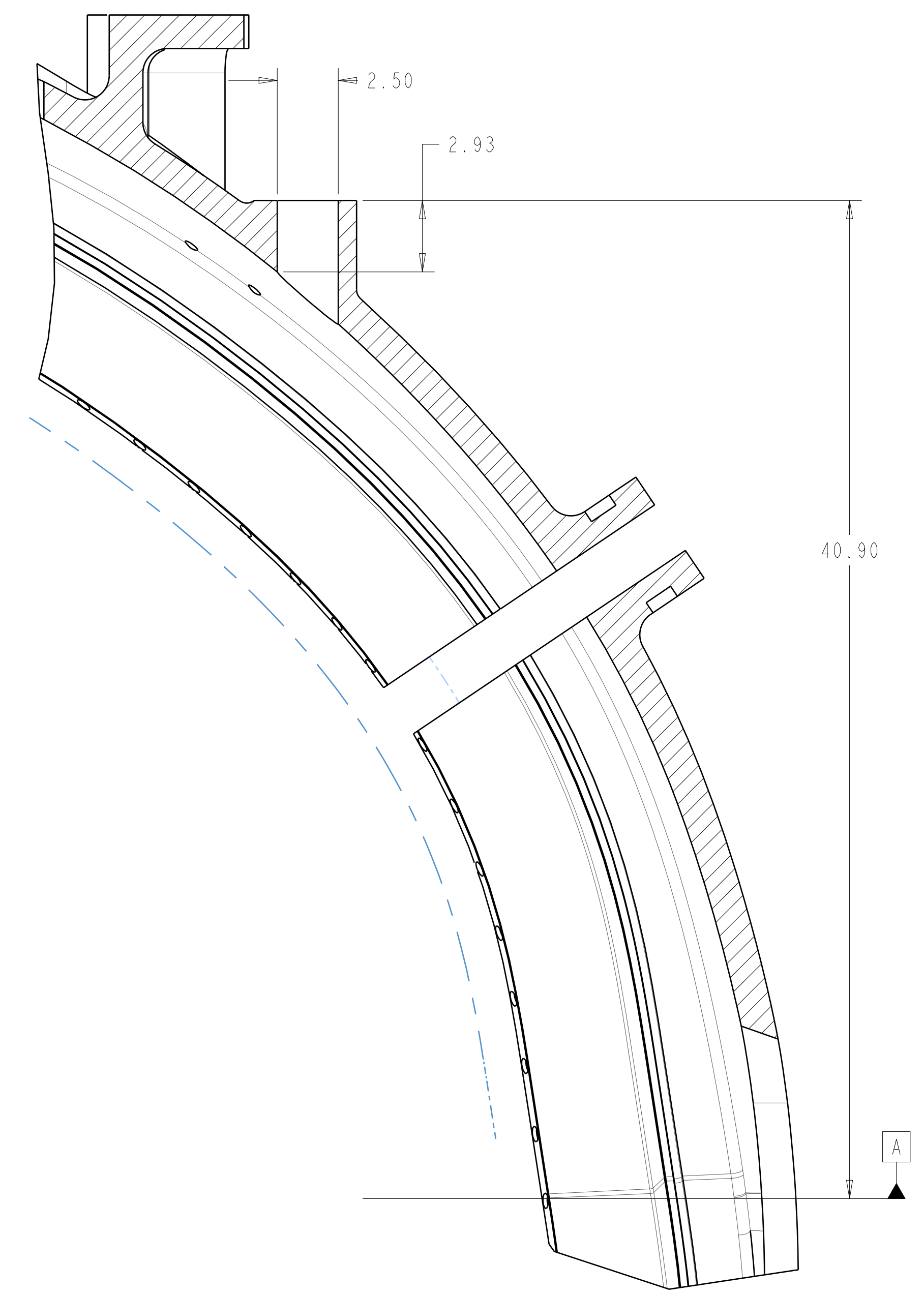

SECTION H-H
SCALE 0.25

**RELEASED FOR
FABRICATION / INSTALLATION**
PPPL Drafting:

Oak Ridge National Laboratory managed for the DEPARTMENT OF ENERGY under U.S. GOVERNMENT contract DE-AC05-00OR22725 UT-BATTELLE, LLC. Oak Ridge, Tennessee PROJECT NAME							
UT-BATTELLE NATIONAL COMPACT STELLARATOR EXPERIMENT PRODUCTION WINDING FORM TYPE-A							
VERSION NO.	PLANT	BLDG	FL	SHT OF	TYPE	CLASS	
9	X-10	5700	3	3	11	S	U
RELEASE LEVEL		SEI41-114		REV		3	
Fabrication							

SEI41-114

FOR NOTES AND PARTS LIST SEE SHEET 1

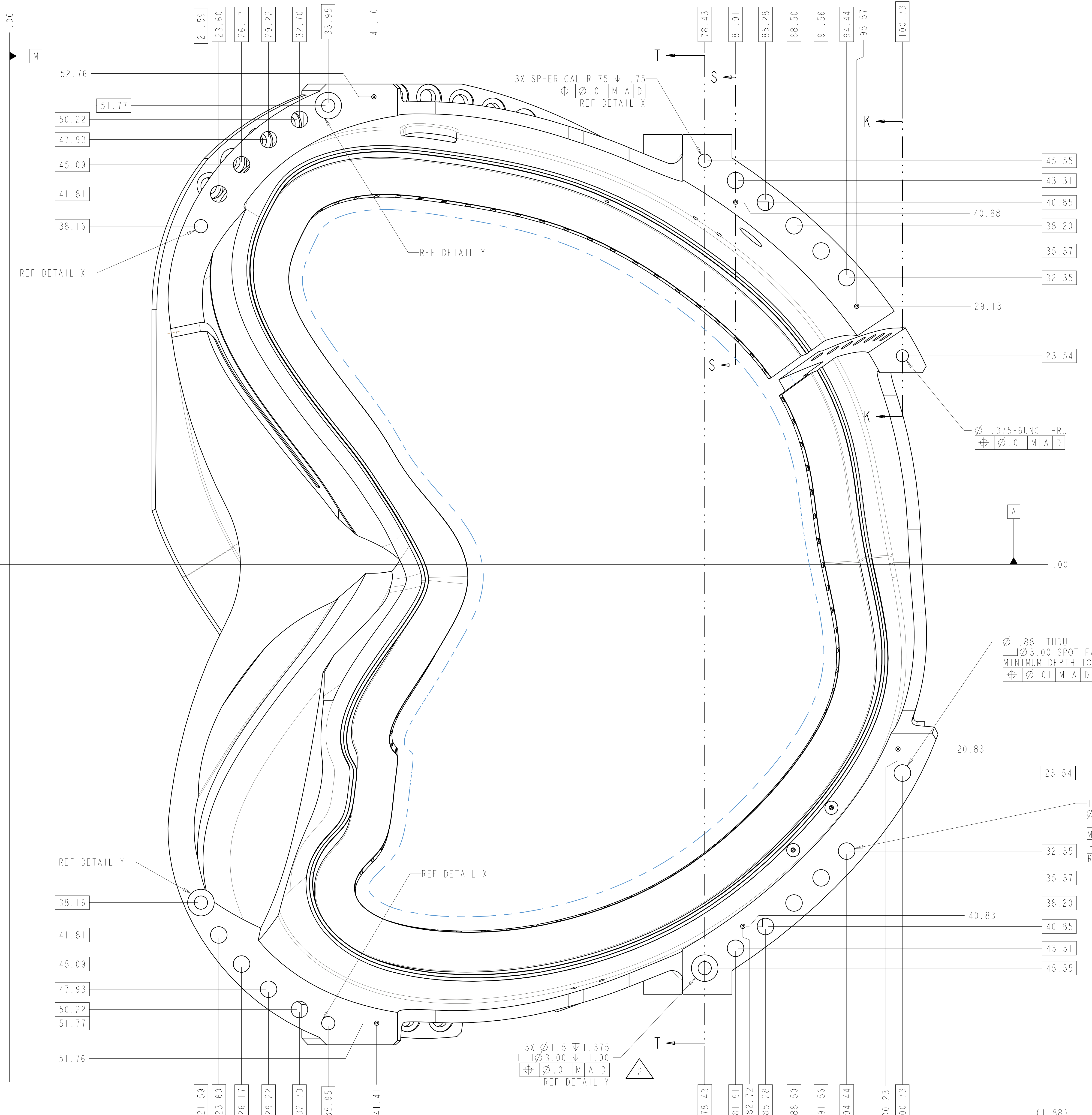

VIEW AT DATUM D
 SCALE 0.20

SEE DETAIL X

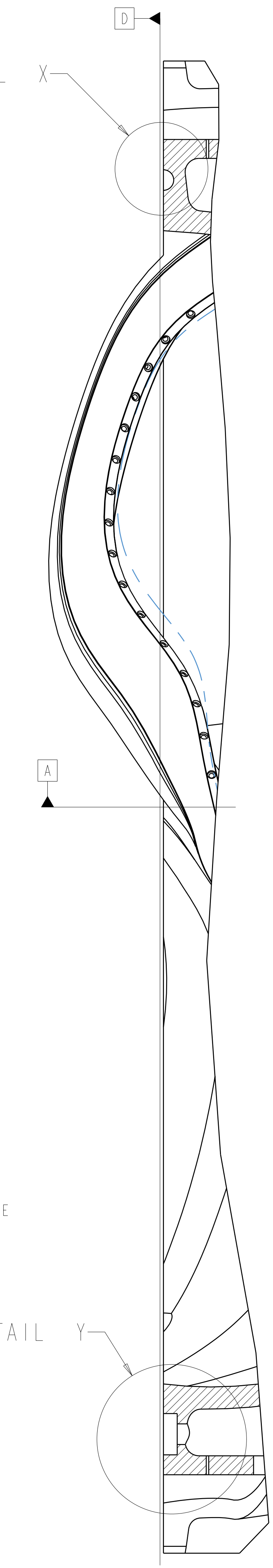

SECTION T-T

SECTION K-K
 SCALE 0.50

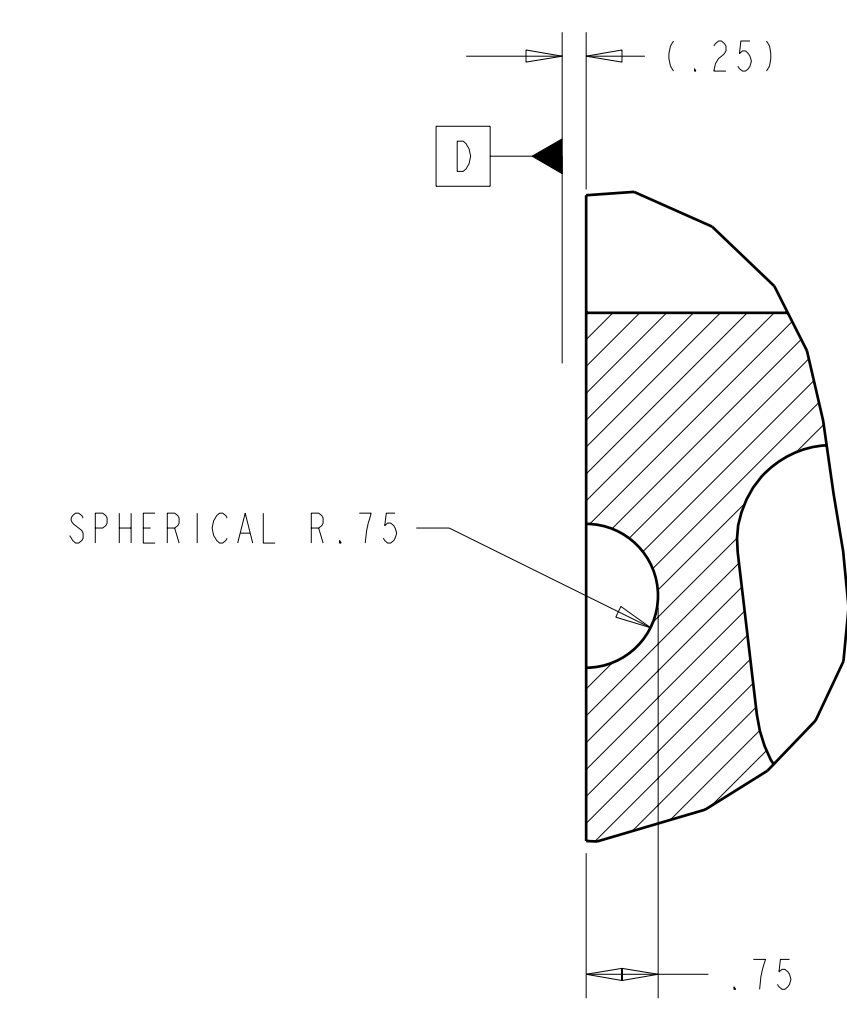

DETAIL X
 SCALE 0.50

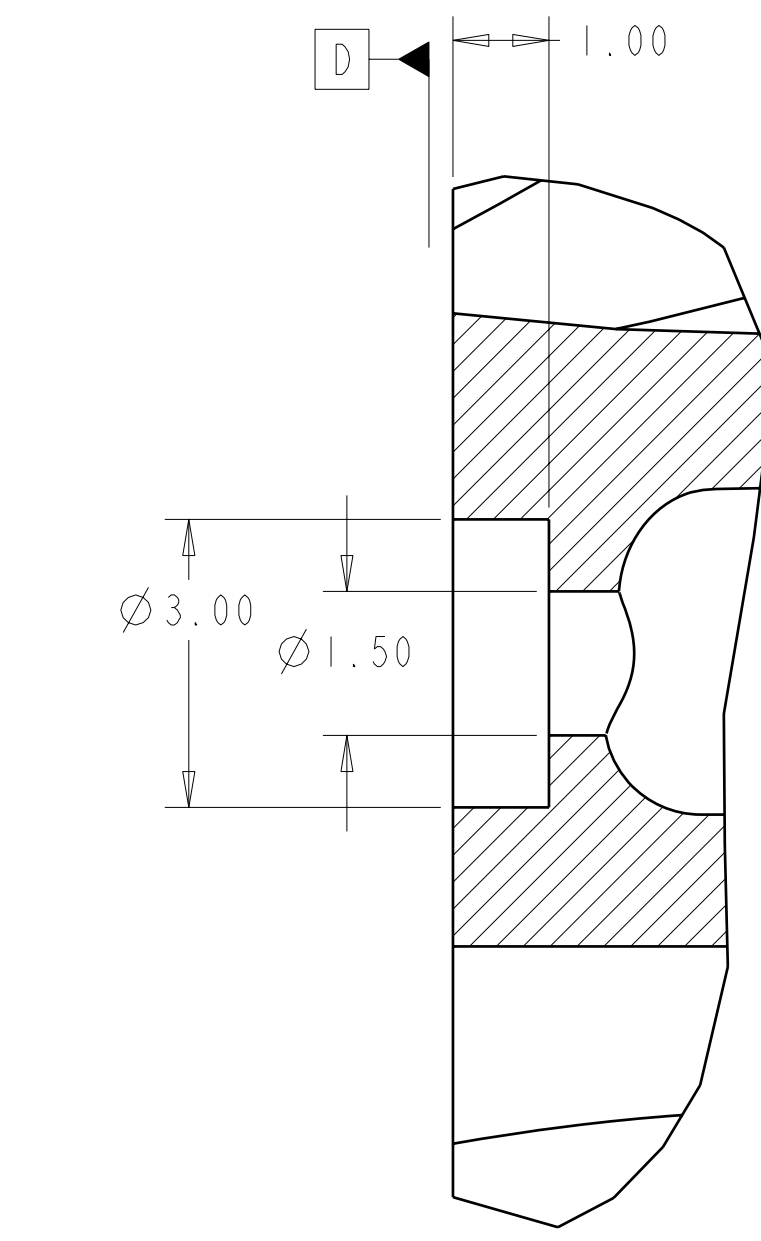

DETAIL Y
 SCALE 0.50

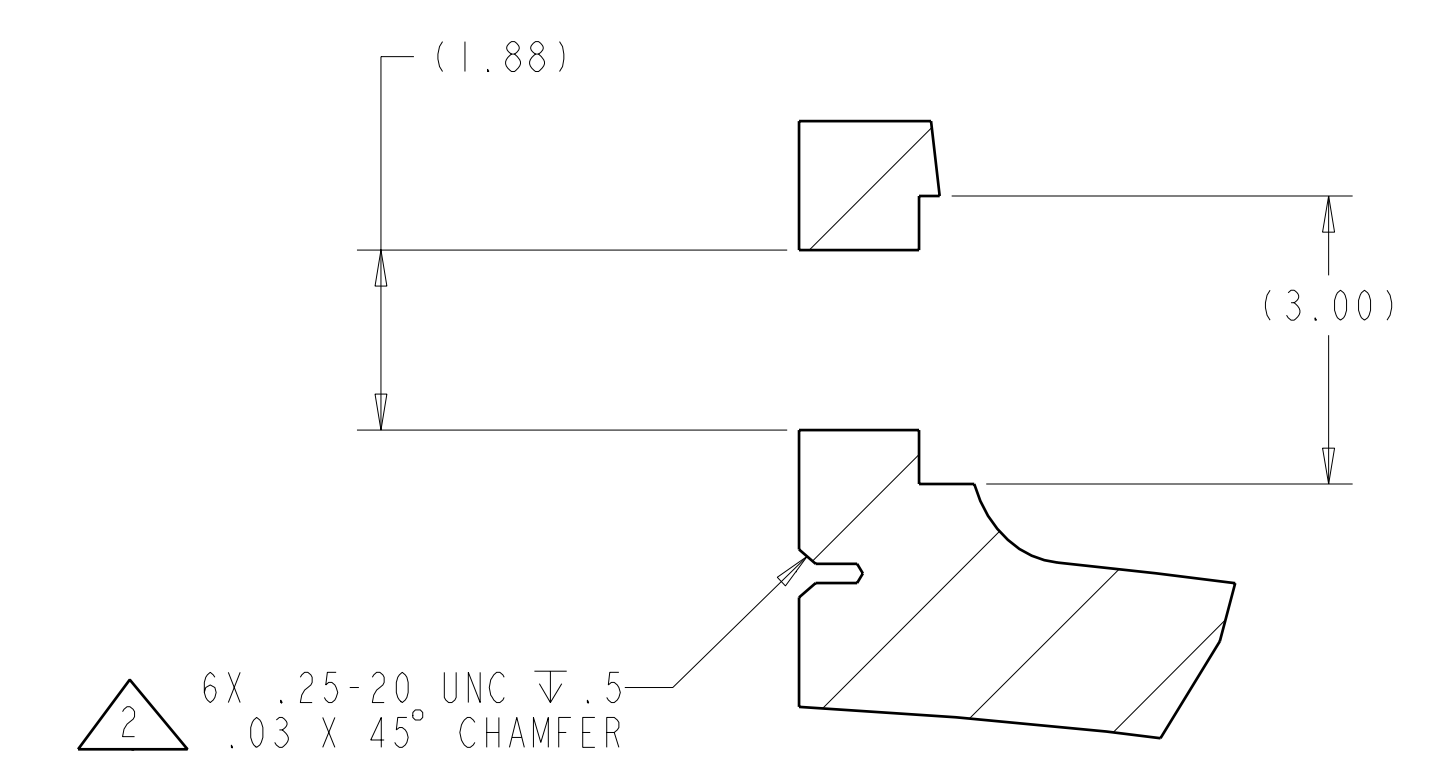

SECTION S-S
 SCALE 0.50

**RELEASED FOR
 FABRICATION / INSTALLATION**
 PPPL Drafting:

Oak Ridge National Laboratory managed for the DEPARTMENT OF ENERGY under U.S. GOVERNMENT contract DE-AC05-00OR22725 UT-BATTELLE, LLC, Oak Ridge, Tennessee PROJECT NAME:							
UT-BATTELLE NATIONAL COMPACT STELLARATOR EXPERIMENT PRODUCTION WINDING FORM TYPE-A							
VERSION NO.	PLANT	BLDG	FL	SHT OF	TYPE	CLASS	
9	X-10	5700	3	4	11	S	U
RELEASE LEVEL	SEI41-114						REV
Fabrication							3

H
G
F
E
D
C
B
A
 SEI41-114

FOR NOTES AND PARTS LIST SEE SHEET 1

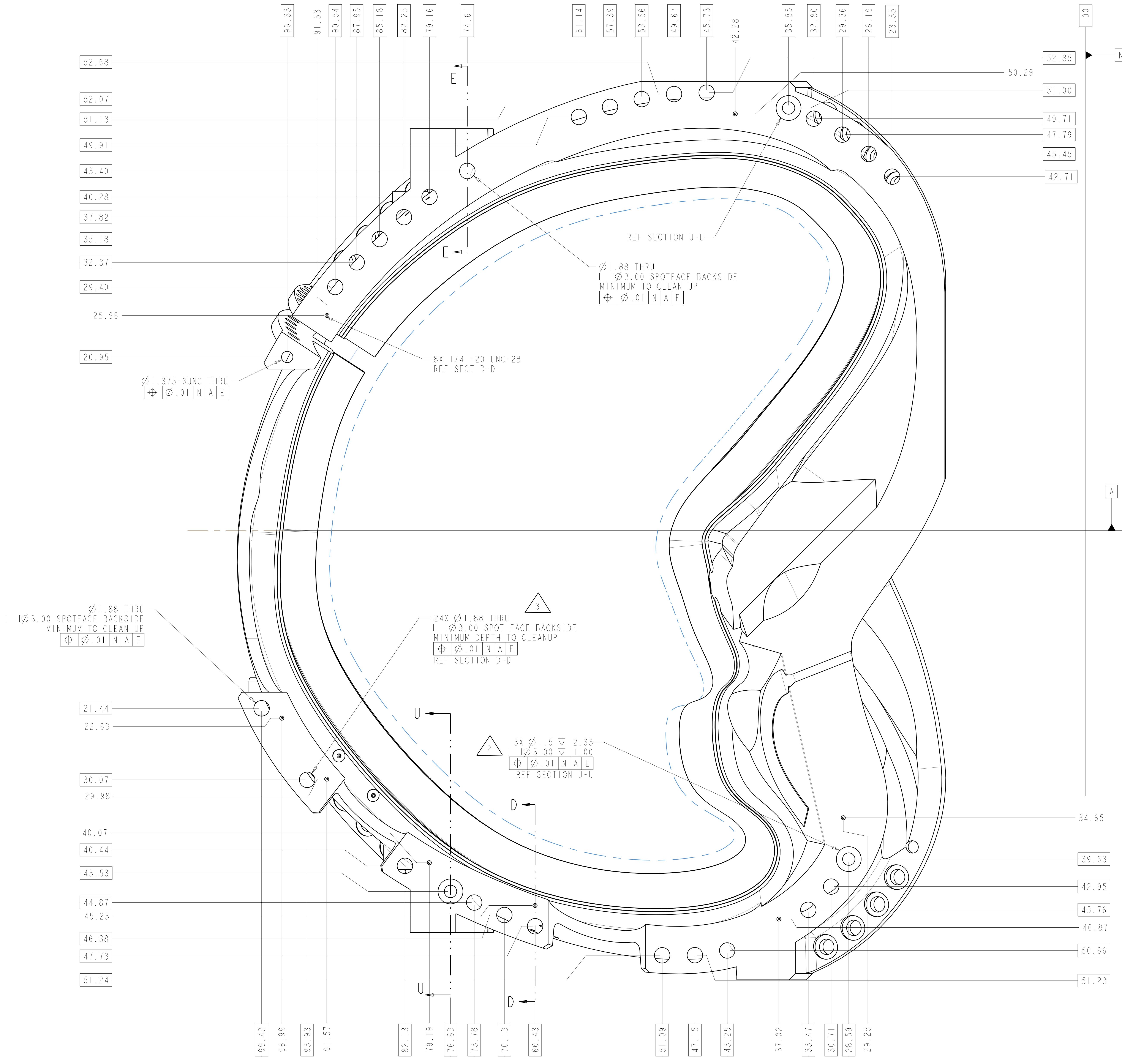

VIEW AT DATUM E
 SCALE 0.20

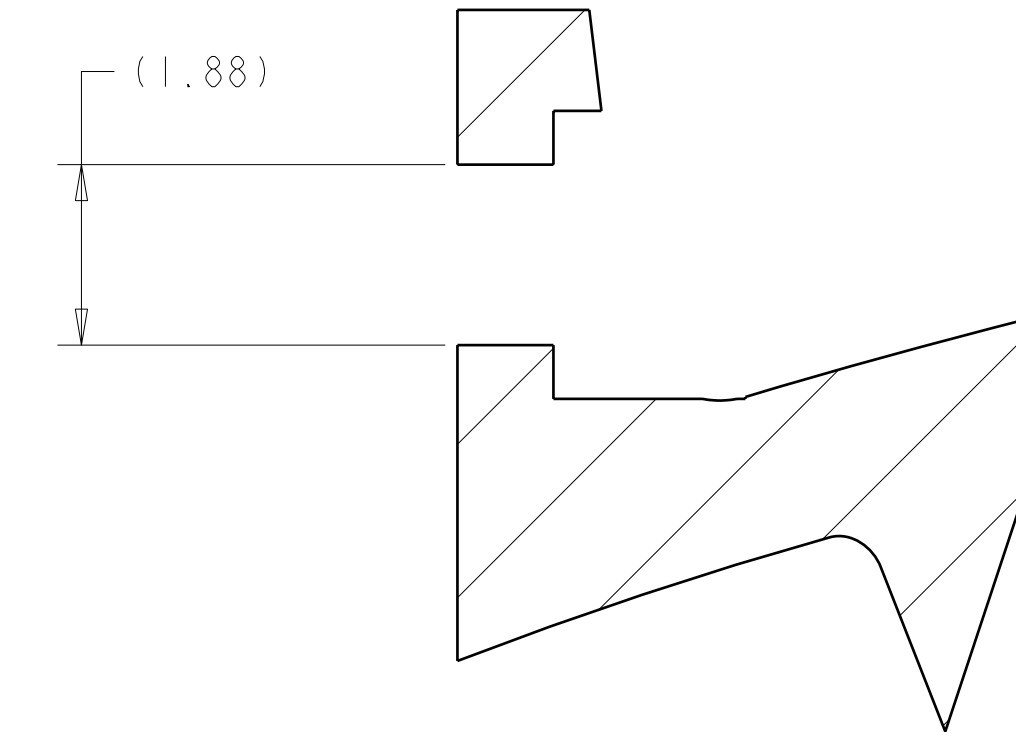

SECTION E-E
 SCALE 0.50

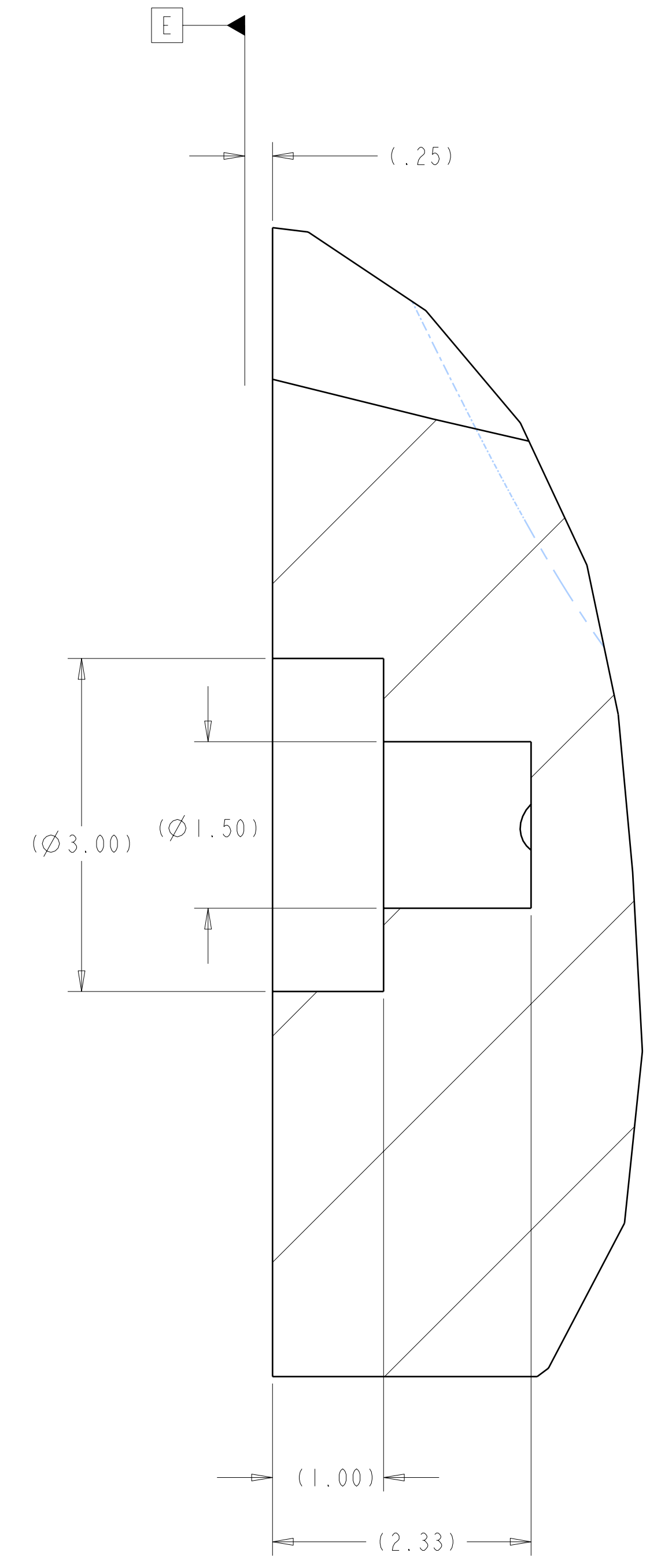

SECTION U-U
 SCALE 1.00

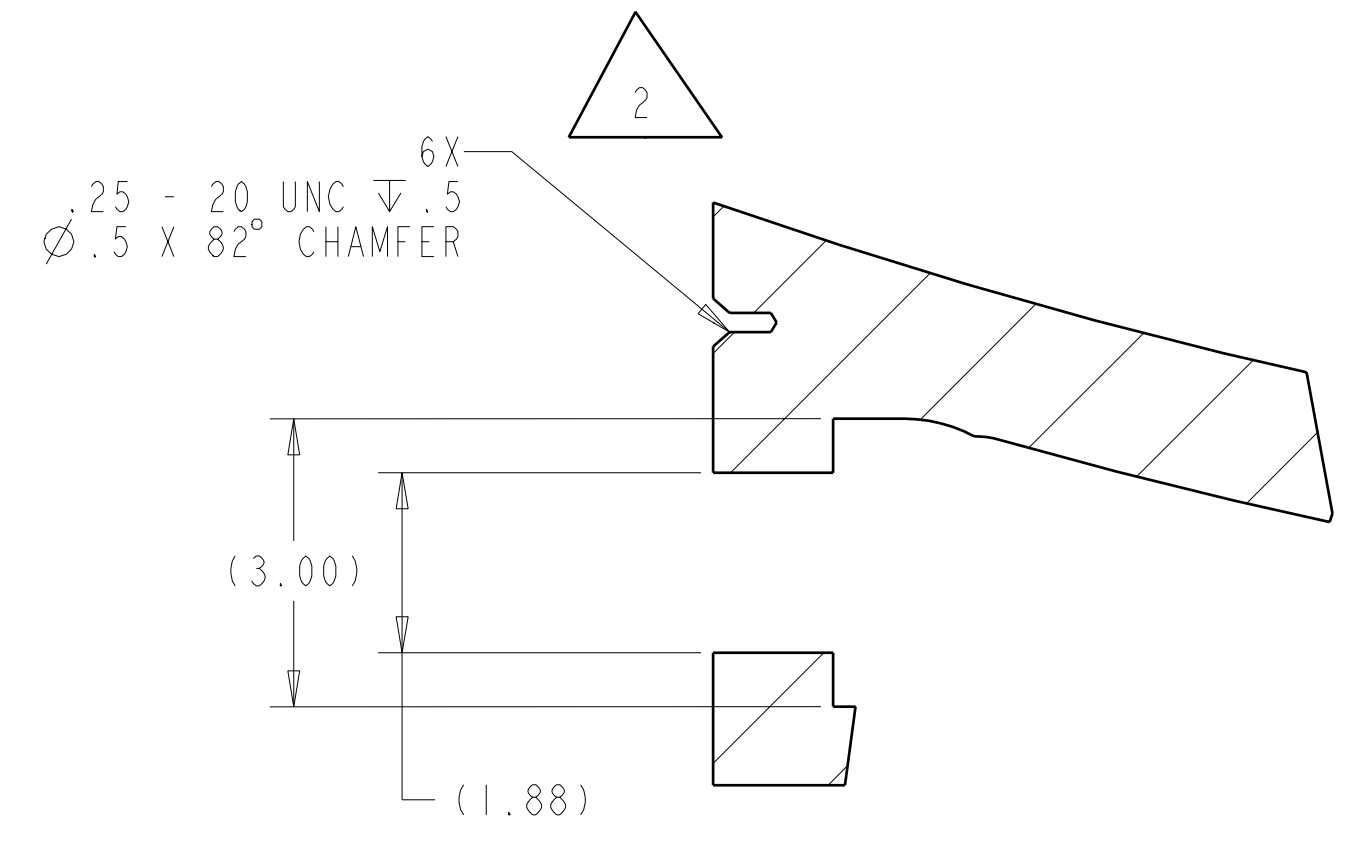

SECTION D-D
 SCALE 0.50

**RELEASED FOR
 FABRICATION / INSTALLATION**
 PPPL Drafting:

Oak Ridge National Laboratory managed for the DEPARTMENT OF ENERGY under U.S. GOVERNMENT contract DE-AC05-00OR22725 UT-BATTELLE, LLC, Oak Ridge, Tennessee PROJECT NAME:							
UT-BATTELLE NATIONAL COMPACT STELLARATOR EXPERIMENT							
PRODUCTION WINDING FORM TYPE-A							
VERSION NO.	PLANT	BLDG	FL	SHT OF	TYPE	CLASS	
9	X-10	5700	3	5	11	S	U
RELEASE LEVEL							REV
Fabrication	SEI41-114						3

H
G
F
E
D
C
B
A
 SEI41-114

FOR NOTES AND PARTS LIST SEE SHEET I

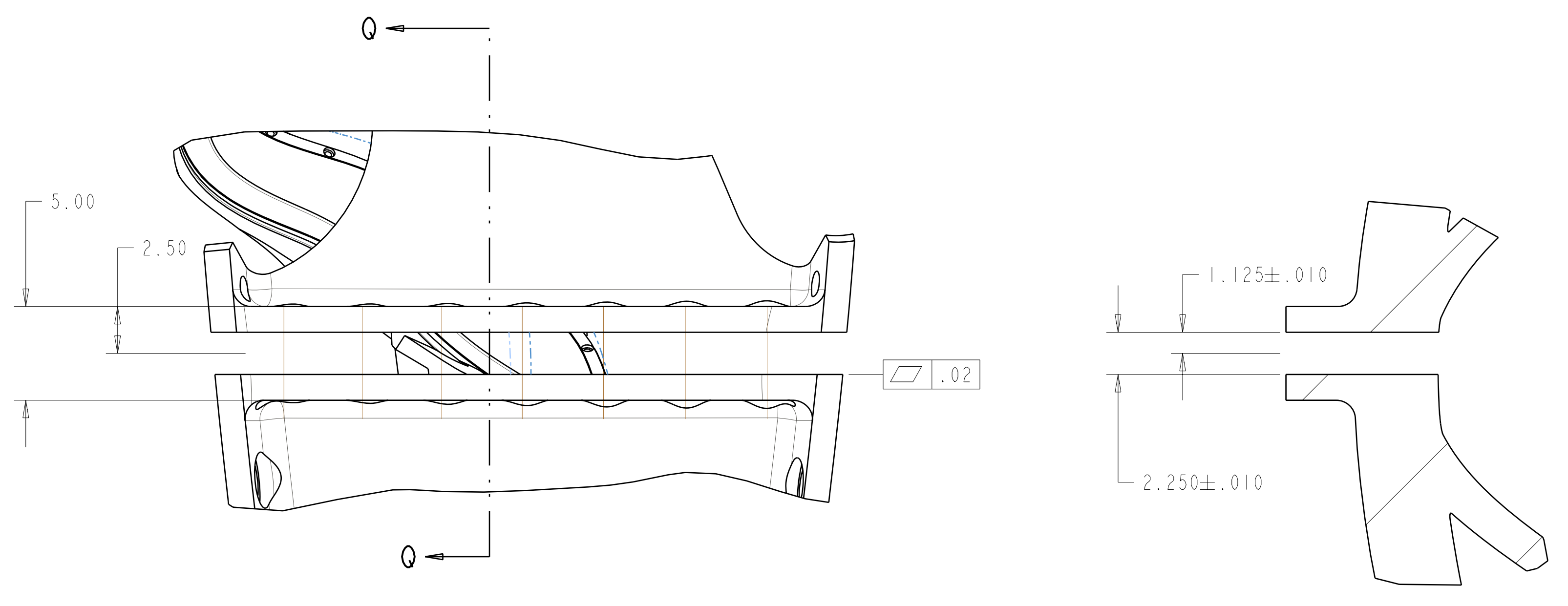

SECTION Q-Q

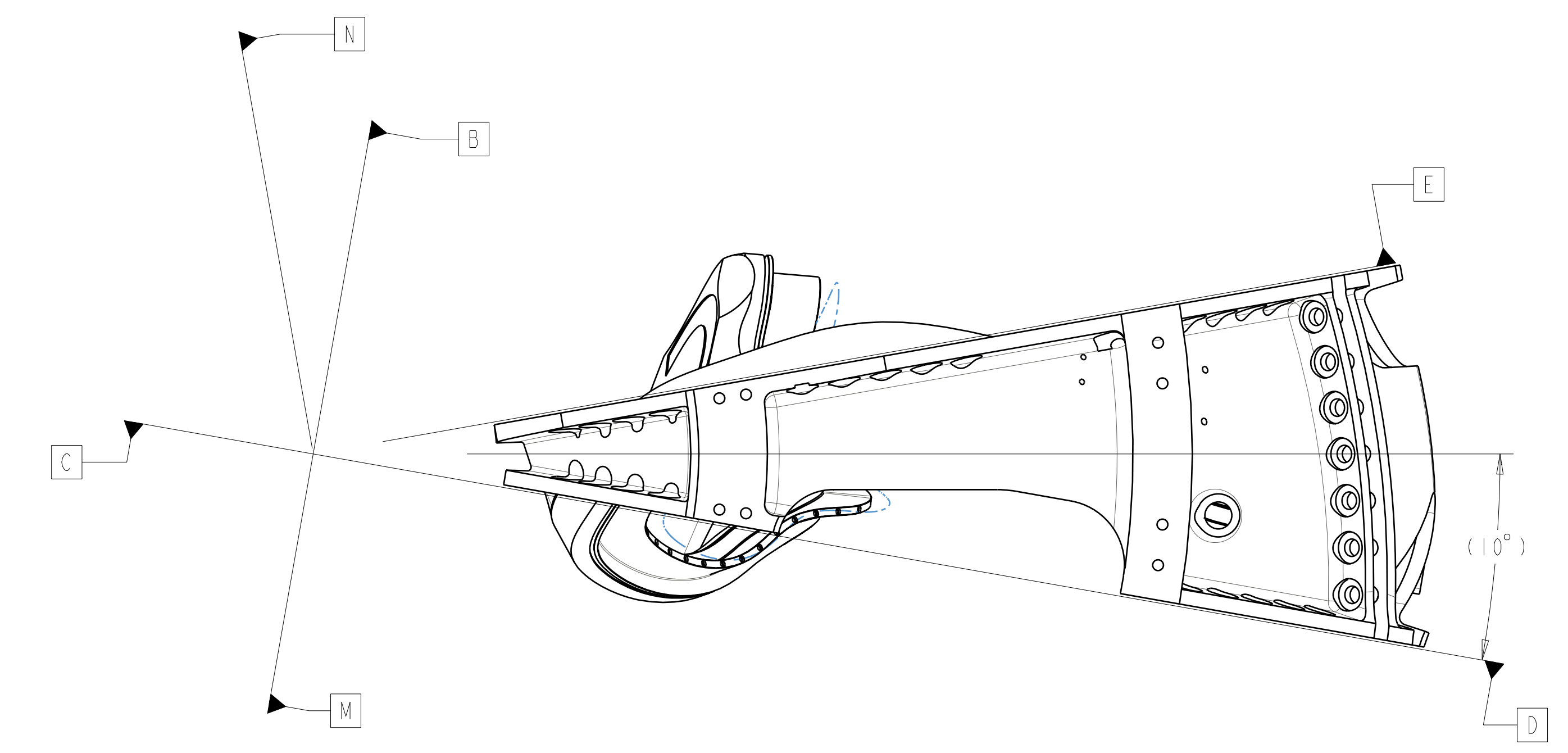

POLOIDAL BREAK DETAIL
 SCALE 0.10

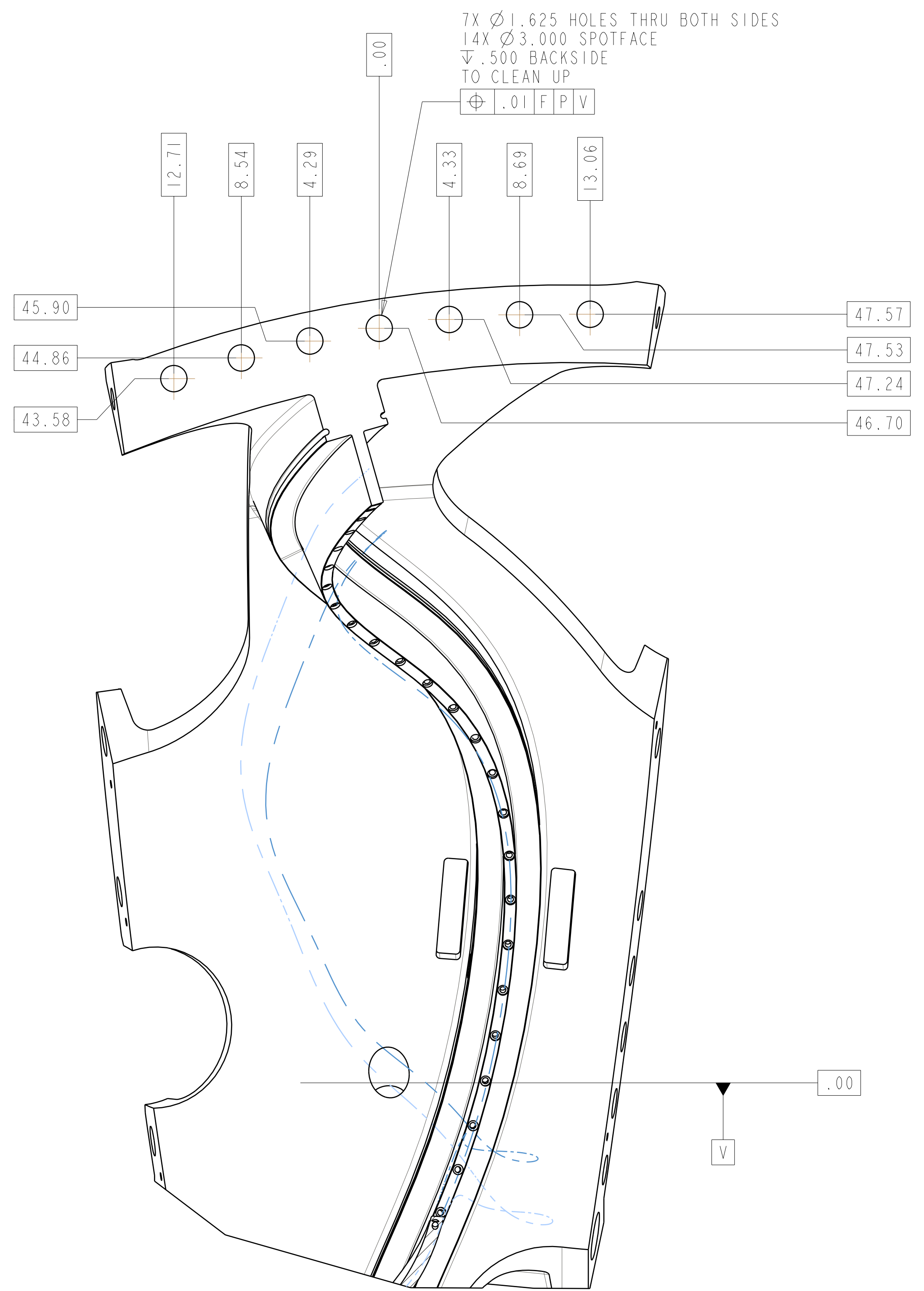

SECTION P-P
 SCALE 0.20

RELEASED FOR FABRICATION / INSTALLATION
 PPPL Drafting:

Oak Ridge National Laboratory managed for the DEPARTMENT OF ENERGY under U.S. GOVERNMENT contract DE-AC05-00OR22725 UT-BATTELLE, LLC, Oak Ridge, Tennessee PROJECT NAME:							
UT-BATTELLE NATIONAL COMPACT STELLARATOR EXPERIMENT PRODUCTION WINDING FORM TYPE-A							
VERSION NO.	PLANT	BLDG	FL	SHT OF	TYPE	CLASS	
9	X-10	5700	3	6	11	S	U
RELEASE LEVEL	SEI41-114						REV
Fabrication							3

SEI41-114

FOR NOTES AND PARTS LIST SEE SHEET 1

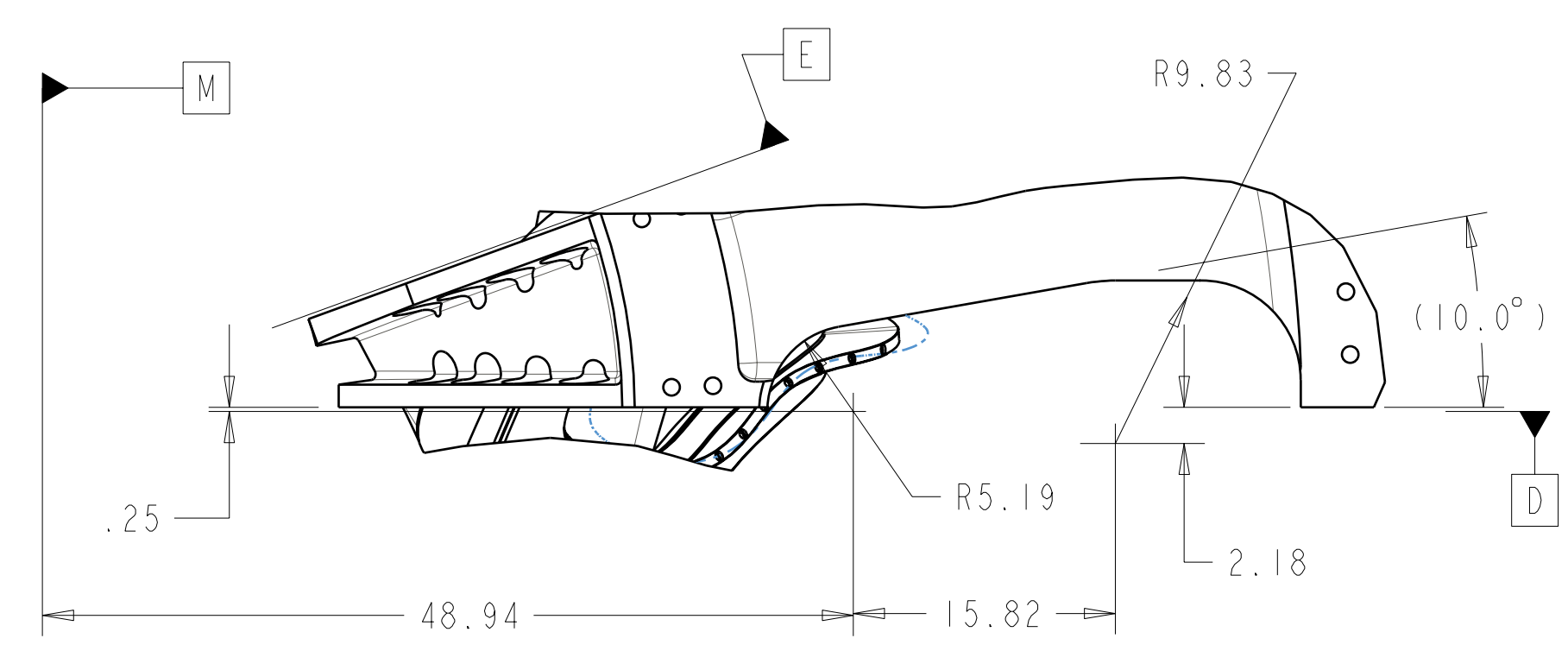

TOP VIEW



SECTION W-W
WING SHIM POCKET
SCALE 0.25

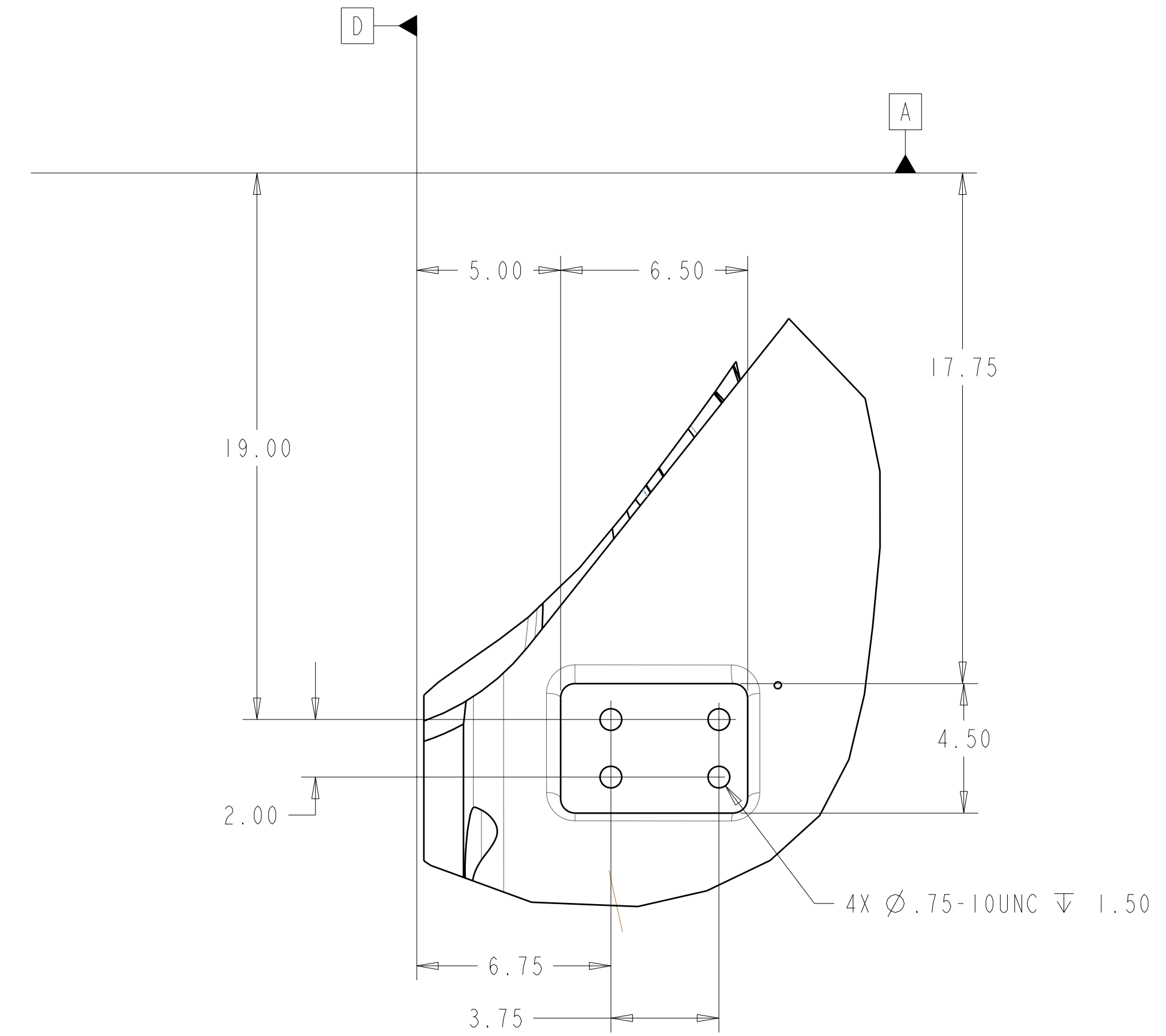

DETAIL J
ASSEMBLY FIXTURE MOUNT
SCALE 0.25

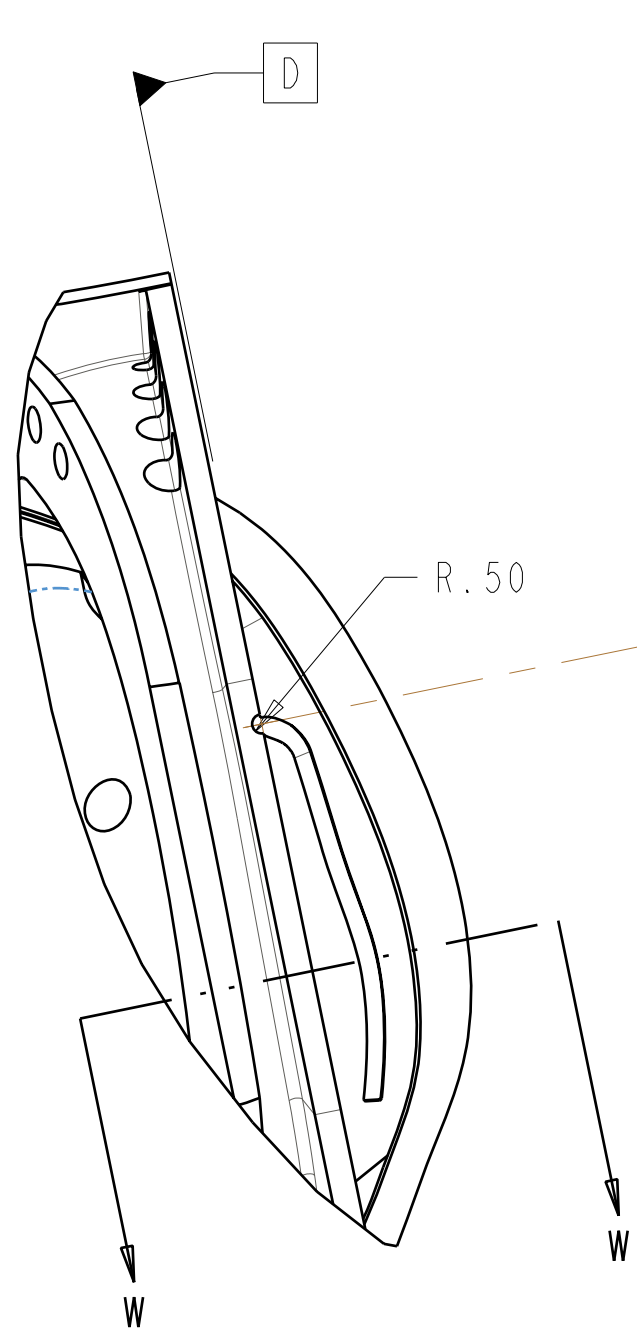

AUX VIEW TO SHOW
WING SHIM POCKET

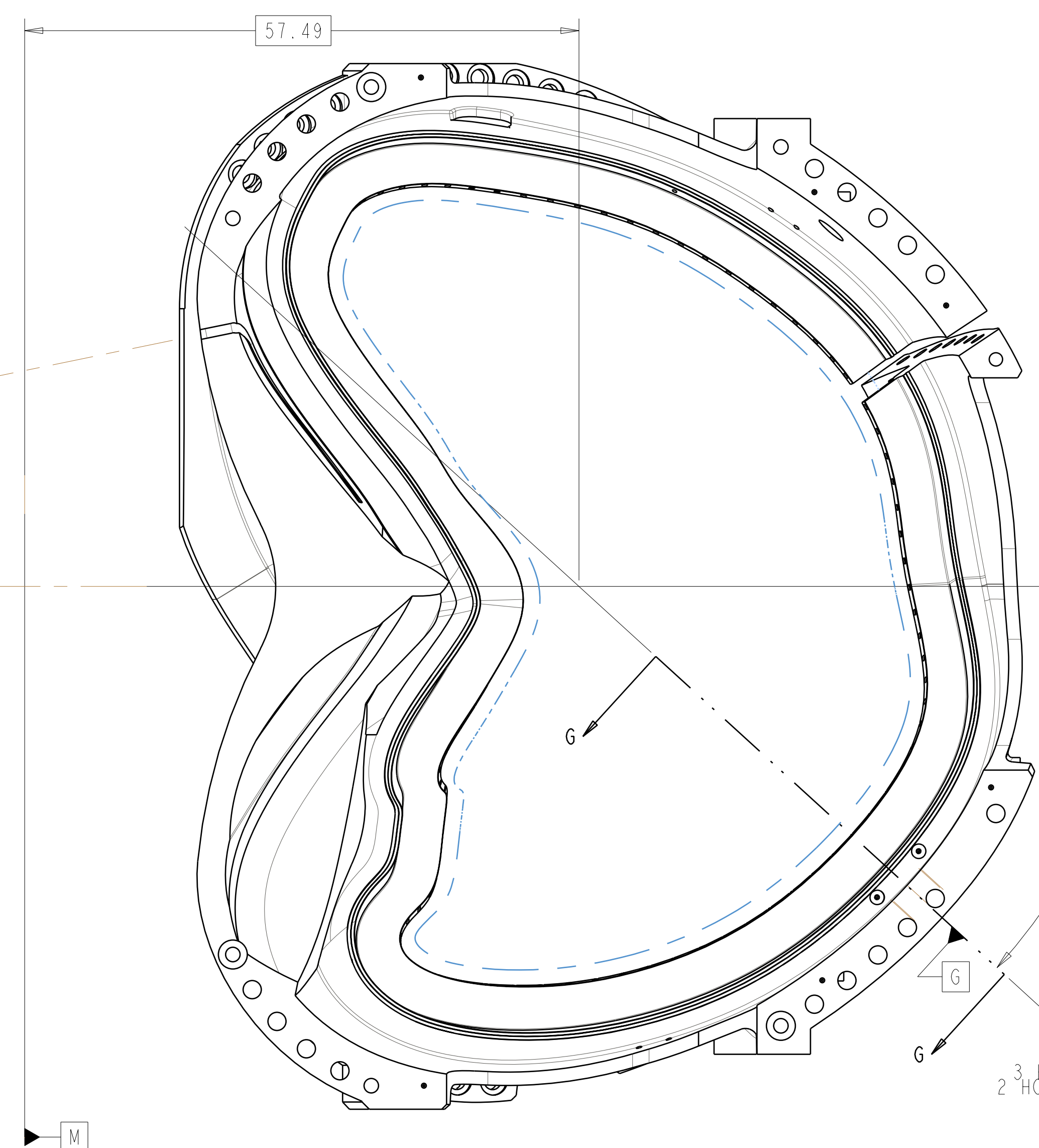

VIEW AT DATUM D
SCALE 0.1

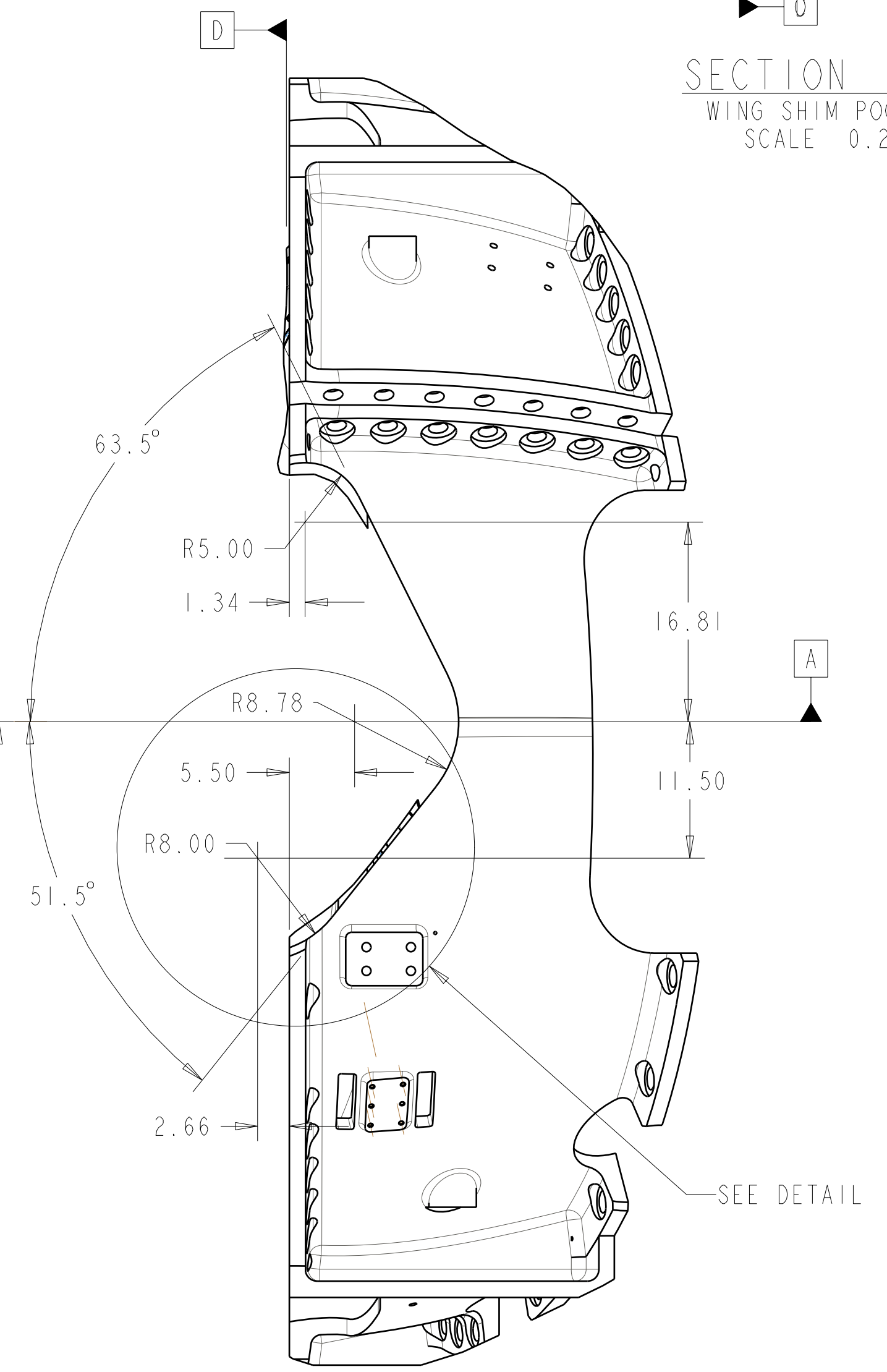

SOME FEATURES NOT SHOWN
FOR CLARITY

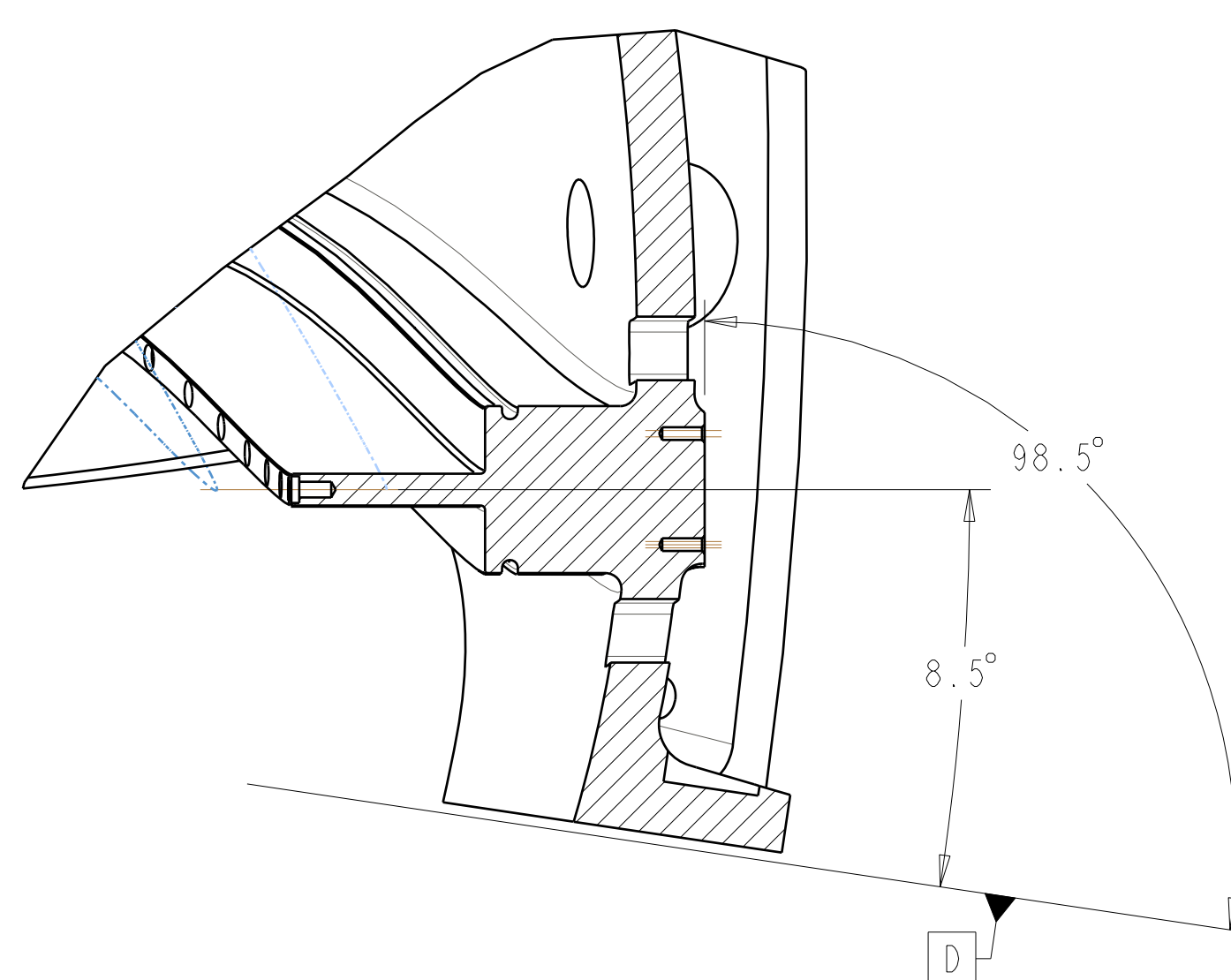

SECTION G-G
LEAD BLOCK DETAIL
SCALE 0.25

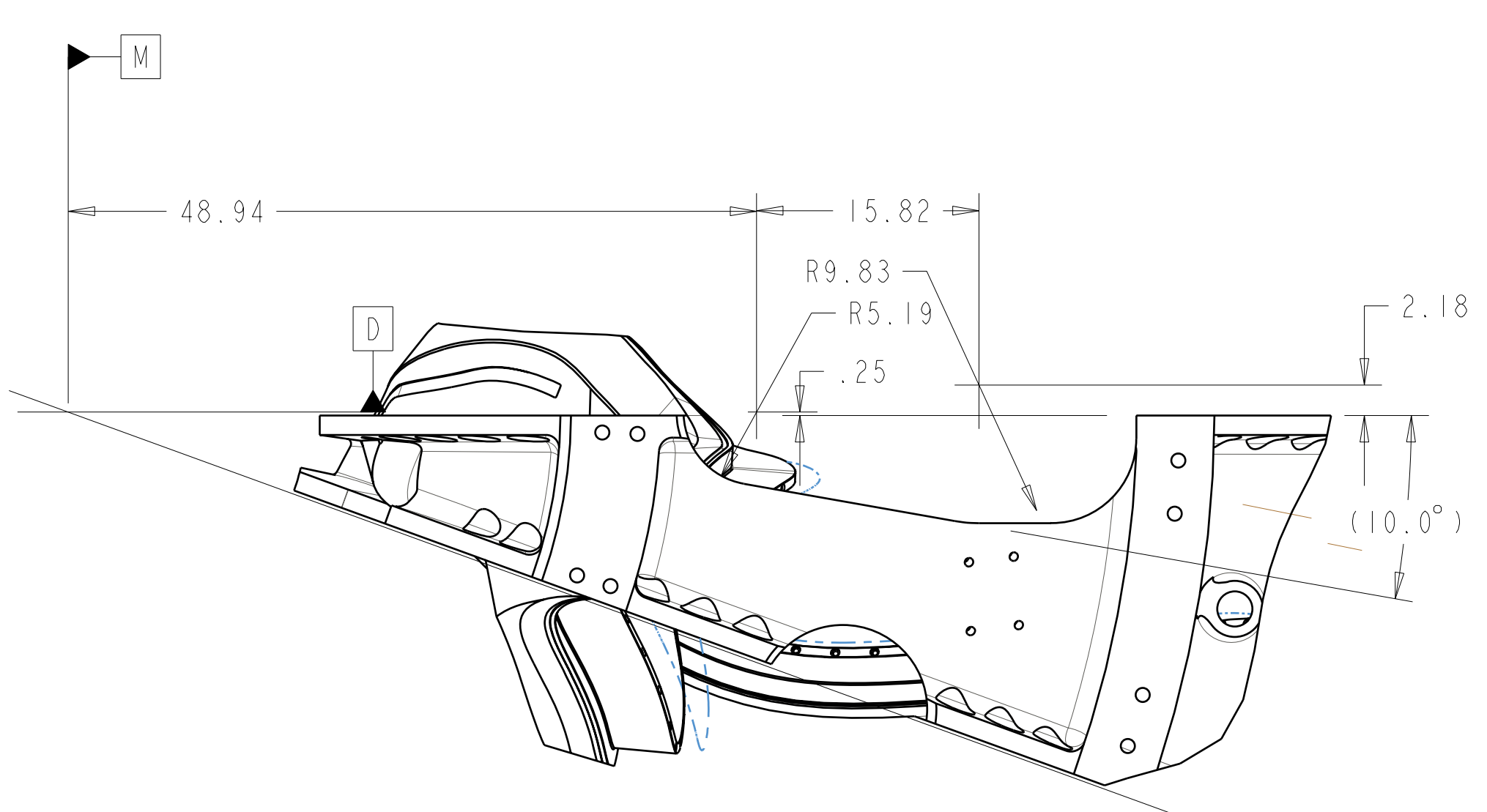
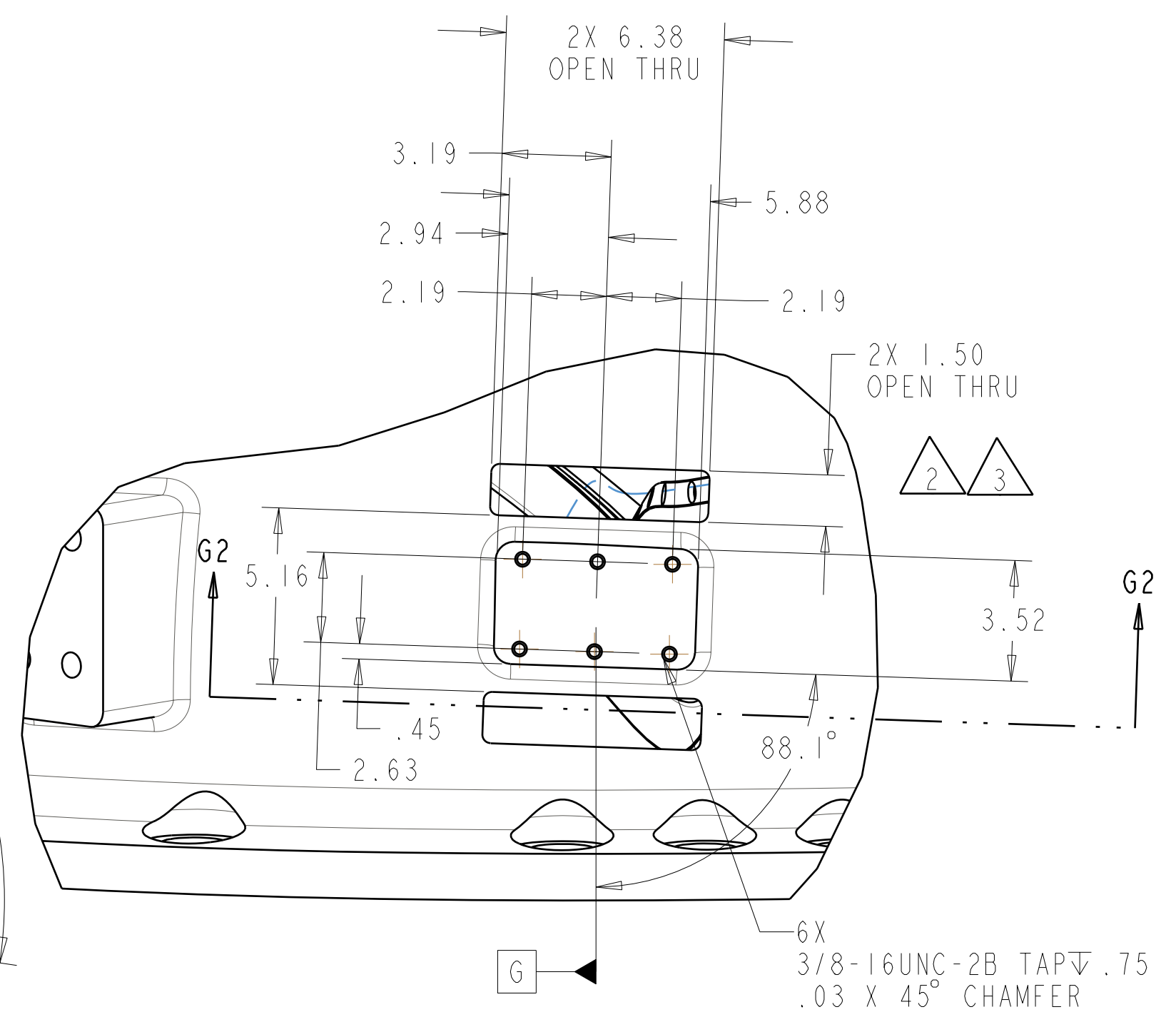

BOTTOM VIEW

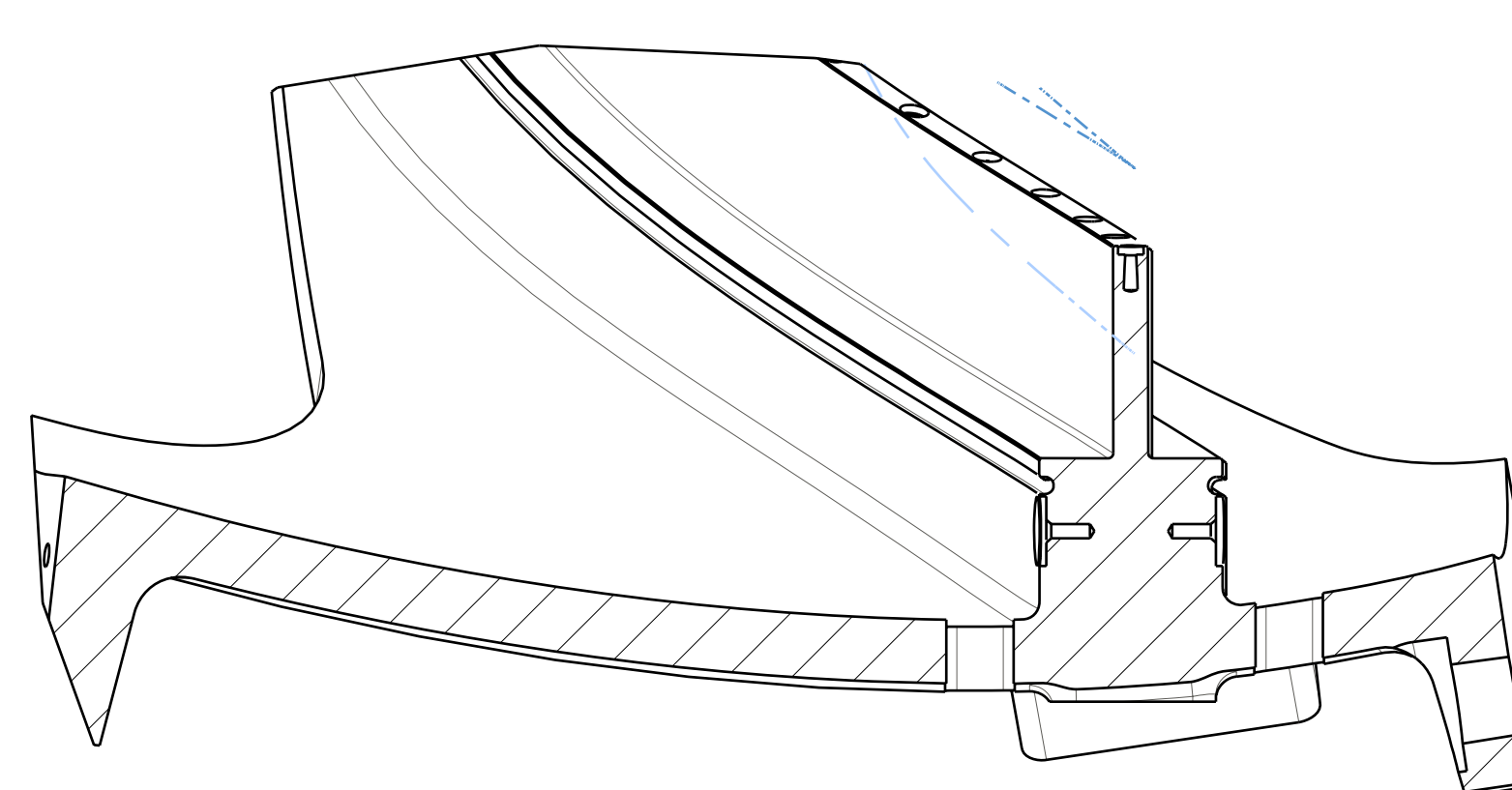

SECTION G3-G3

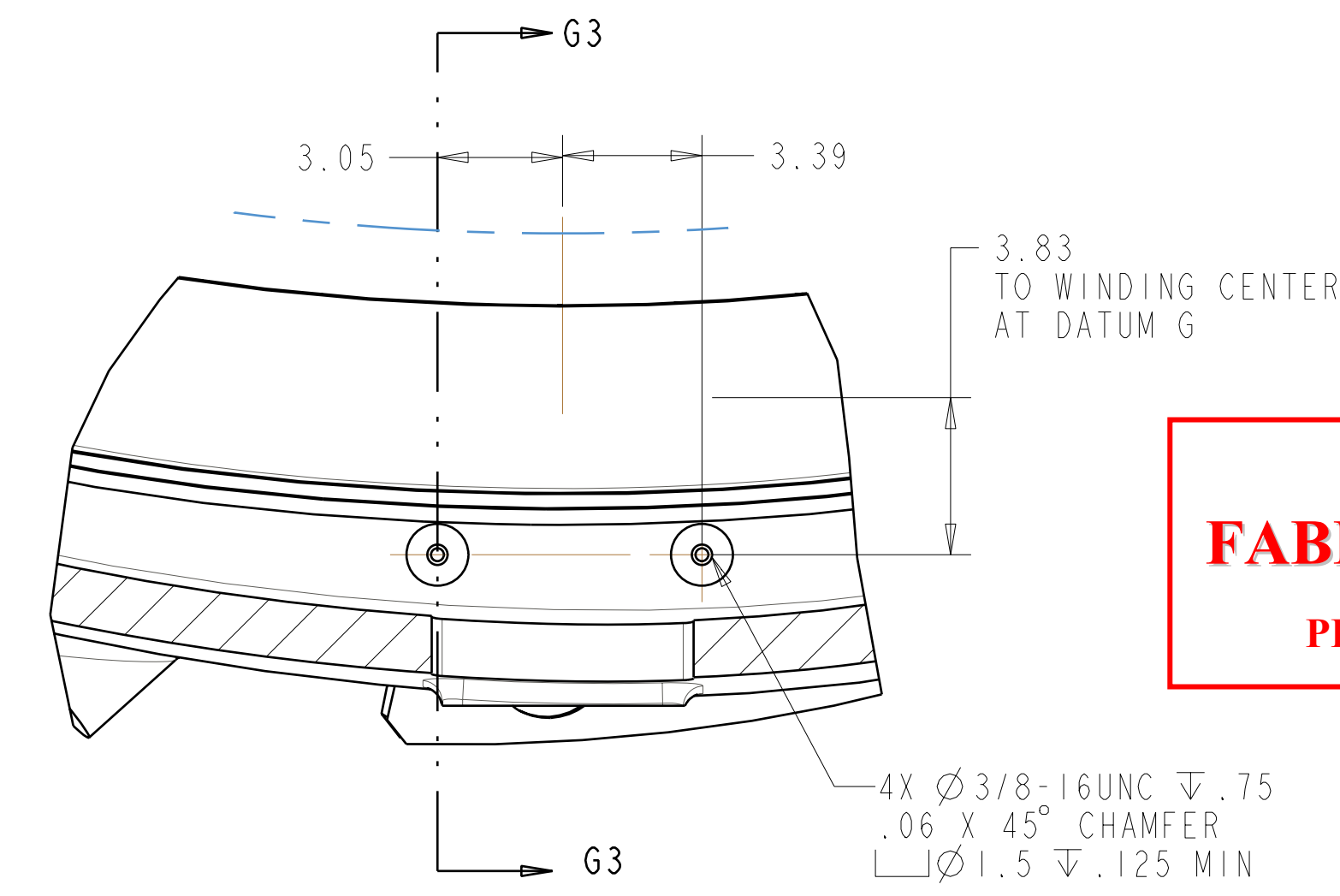

SECTION G2-G2
SCALE 0.250

**RELEASED FOR
FABRICATION / INSTALLATION**
PPPL Drafting:

Oak Ridge National Laboratory managed for the DEPARTMENT OF ENERGY under U.S. GOVERNMENT contract DE-AC05-00OR22725 UT-BATTELLE, LLC, Oak Ridge, Tennessee PROJECT NAME:							
UT-BATTELLE NATIONAL COMPACT STELLARATOR EXPERIMENT PRODUCTION WINDING FORM TYPE-A							
VERSION NO.	PLANT	BLDG	FL	SHT OF	TYPE	CLASS	
9	X-10	5700	3	7	11	S	U
RELEASE LEVEL		SEI41-114		REV		3	
Fabrication							

SEI41-114

A

FOR NOTES AND PARTS LIST SEE SHEET 1

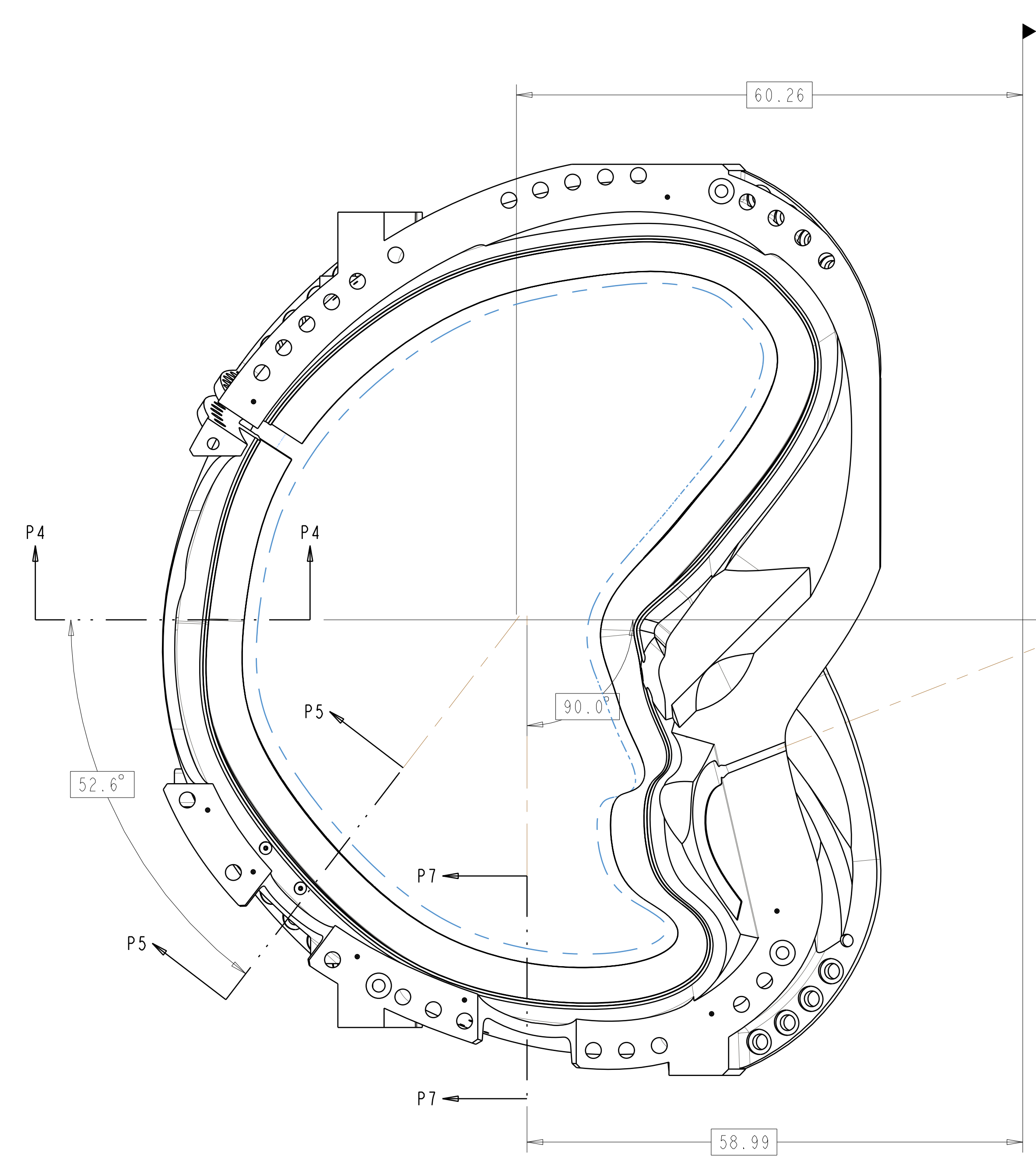

VIEW AT DATUM E
 SCALE 0.1

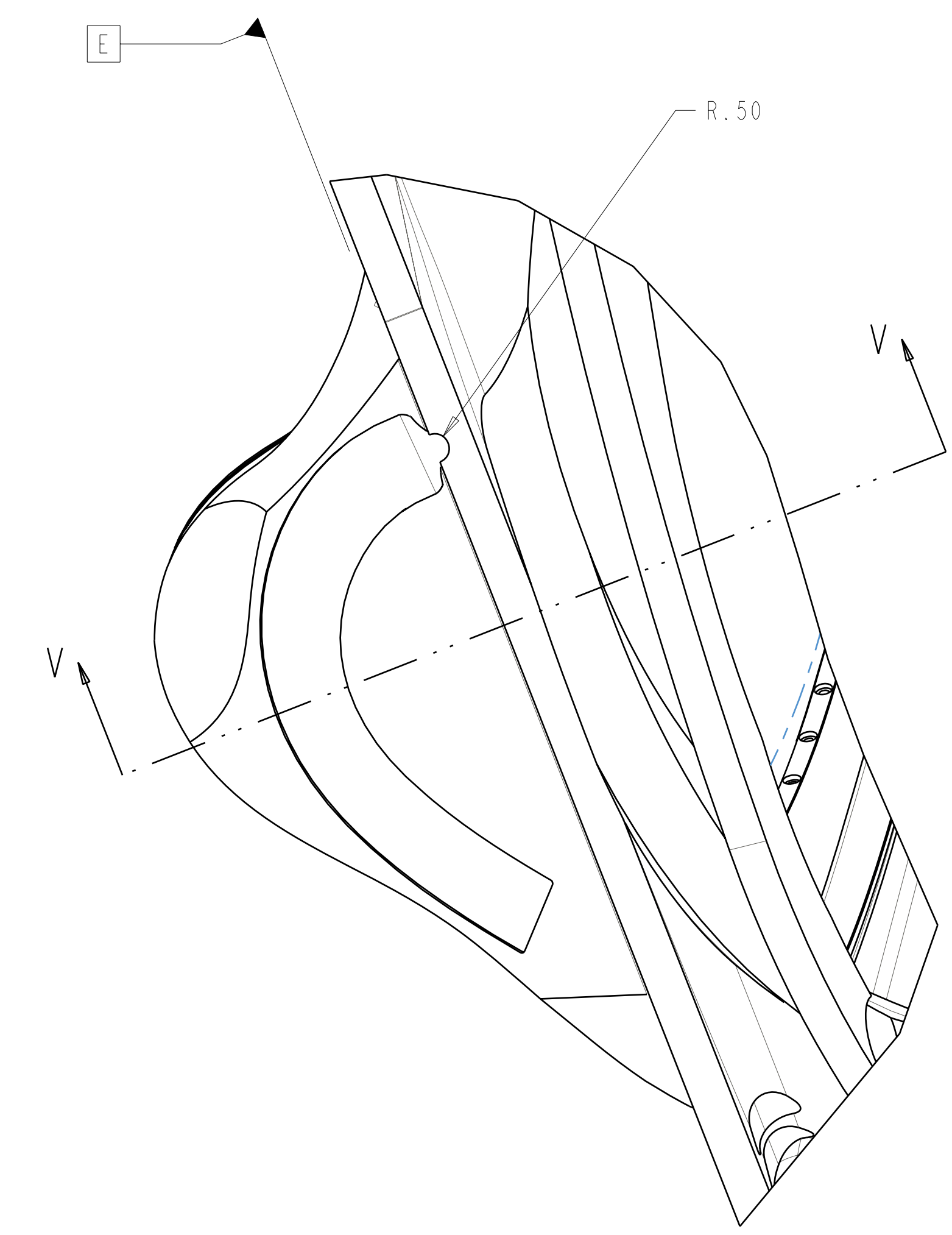
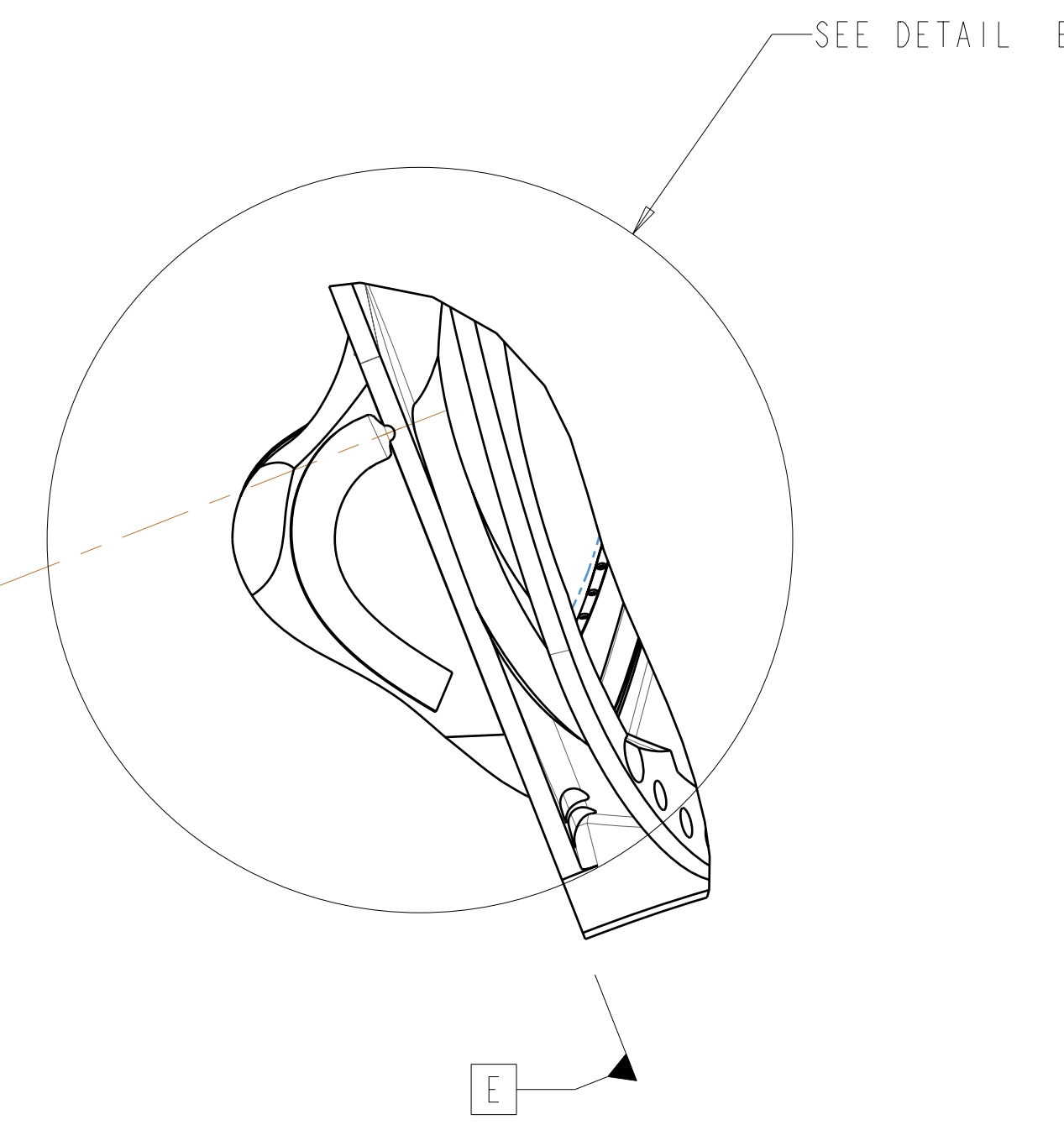

DETAIL E
 WING SHIM POCKET
 SCALE 0.25

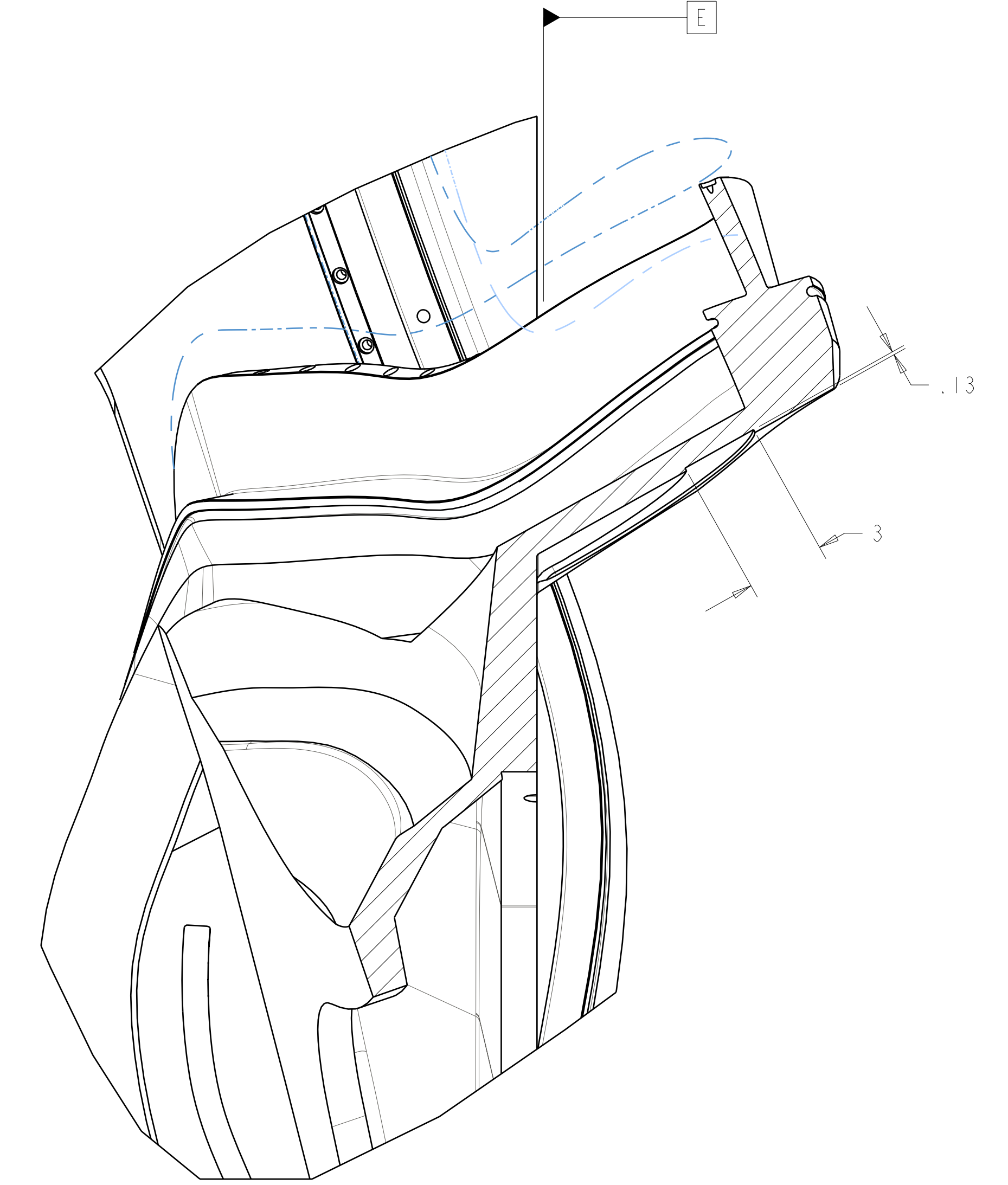

SECTION V-V
 SCALE 0.25

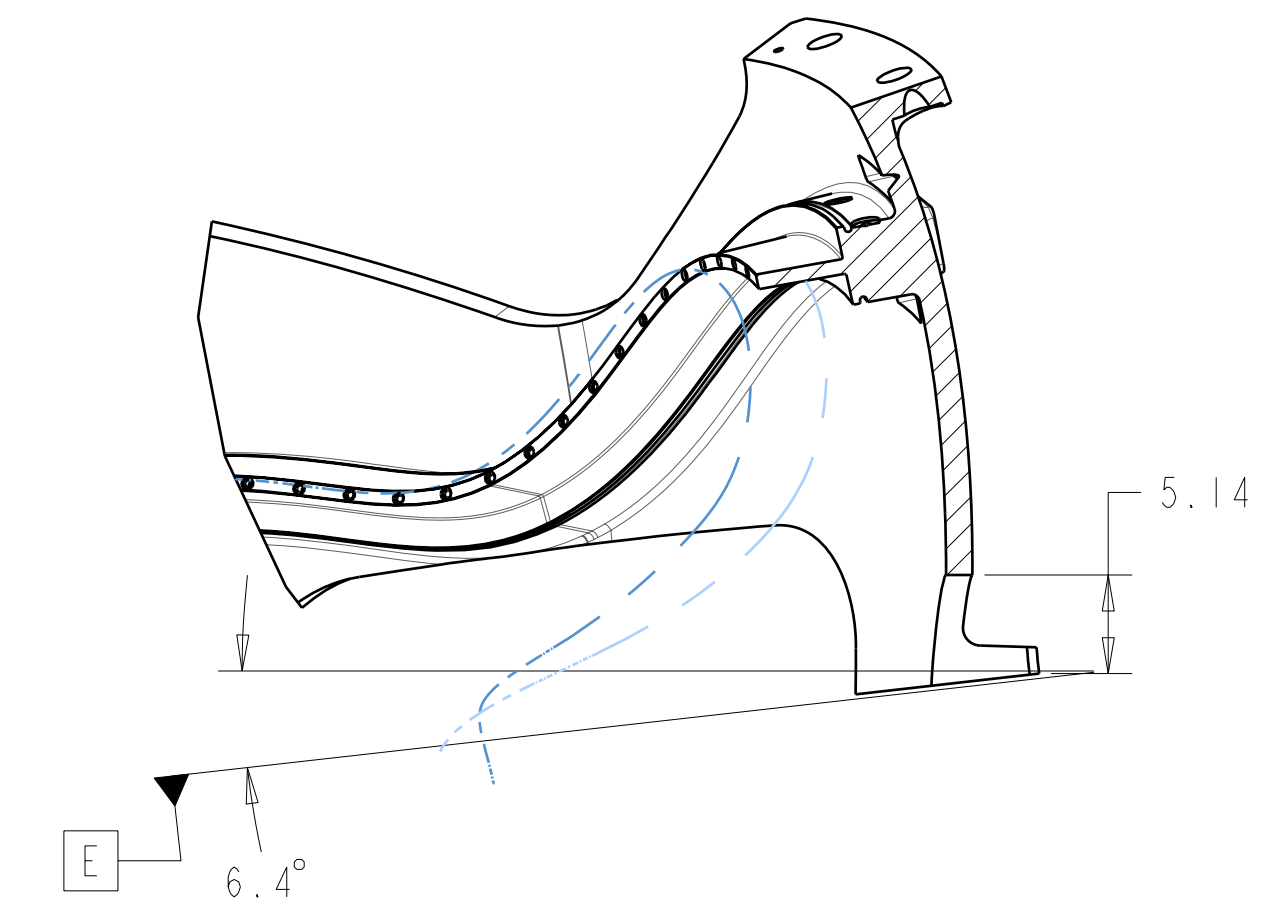

SECTION P5-P5
 SCALE 0.1

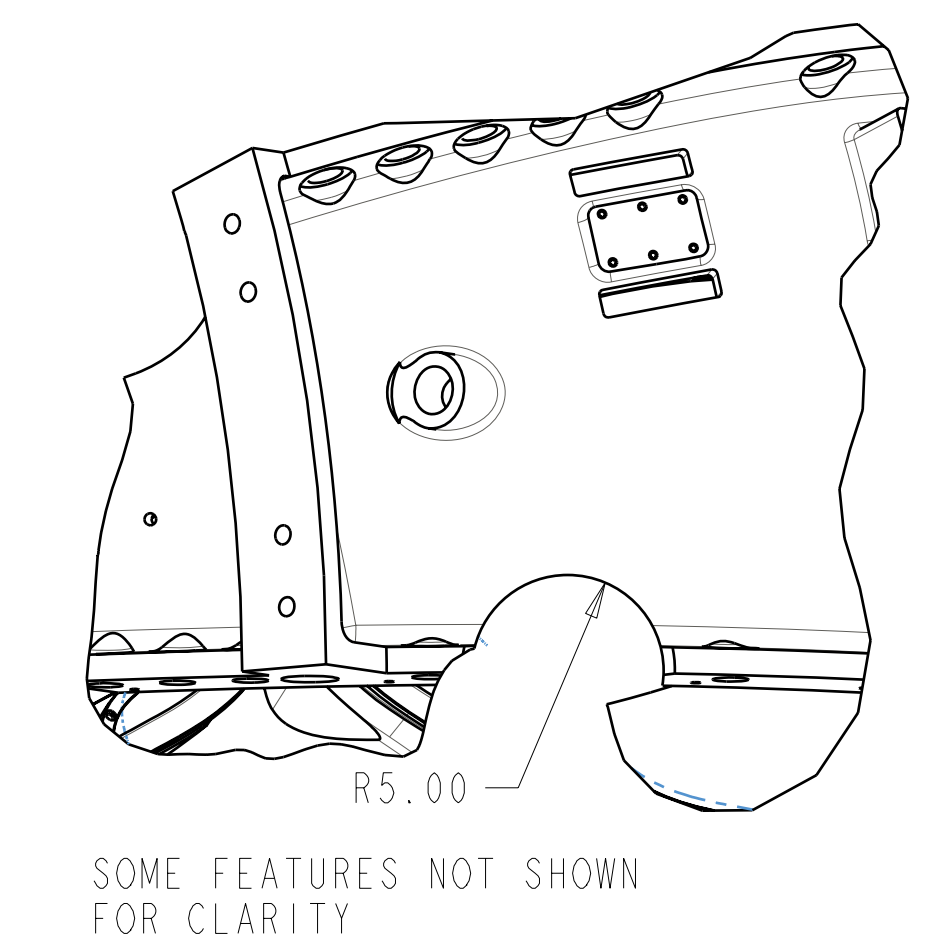

SOME FEATURES NOT SHOWN FOR CLARITY

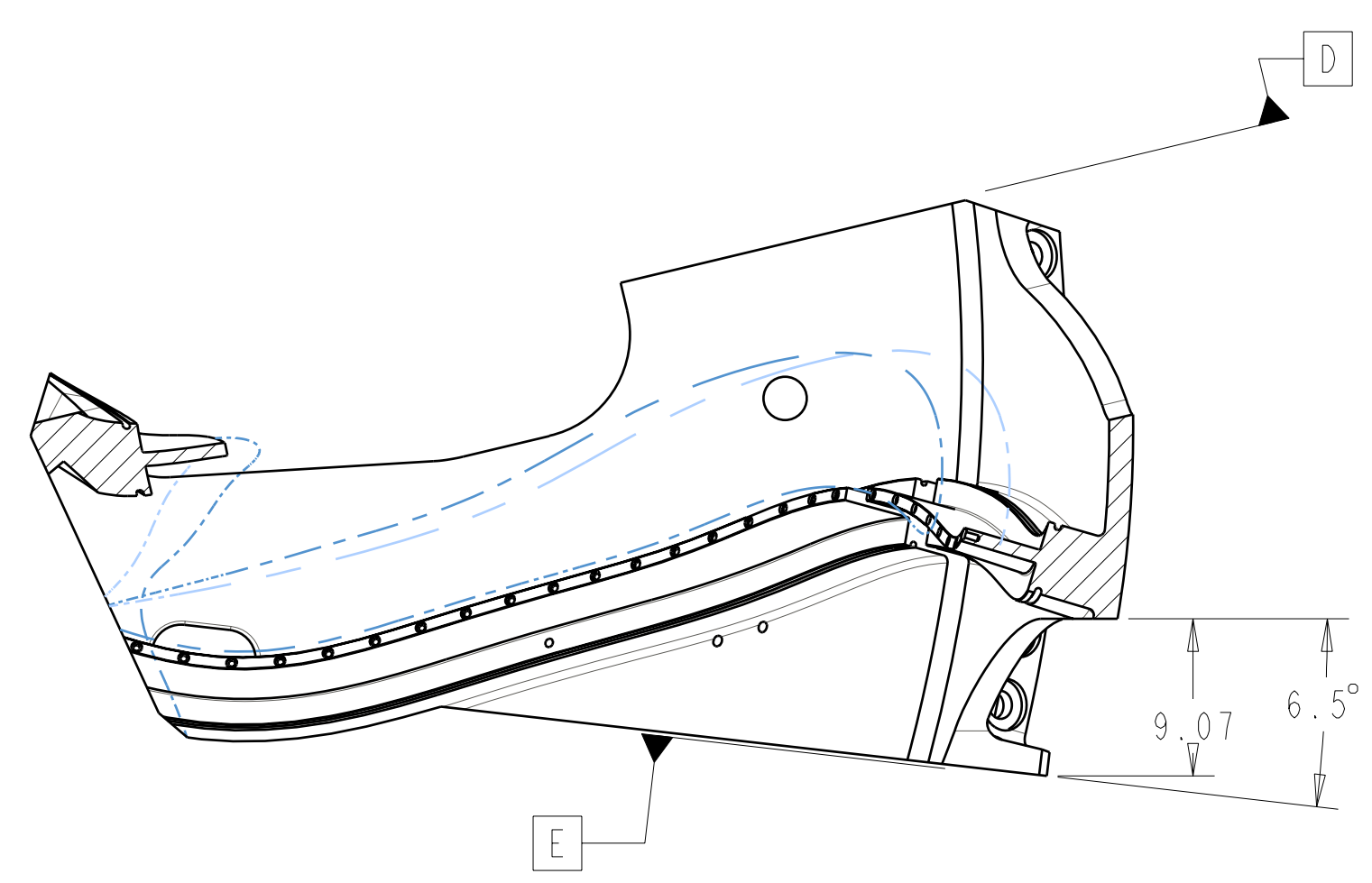

SECTION P4-P4
 SCALE 0.1

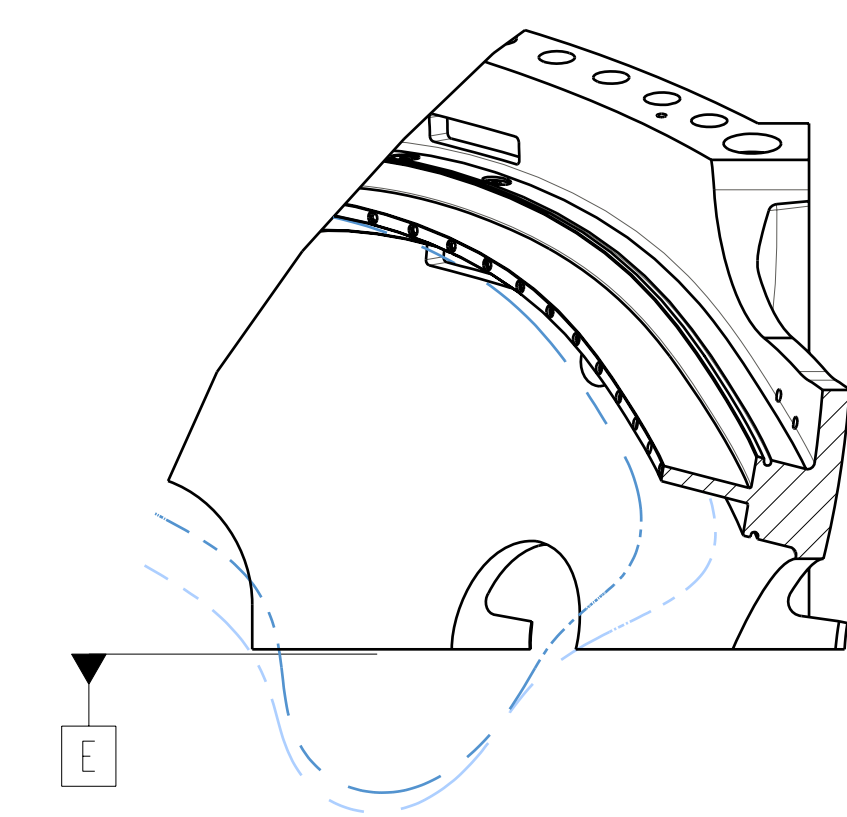
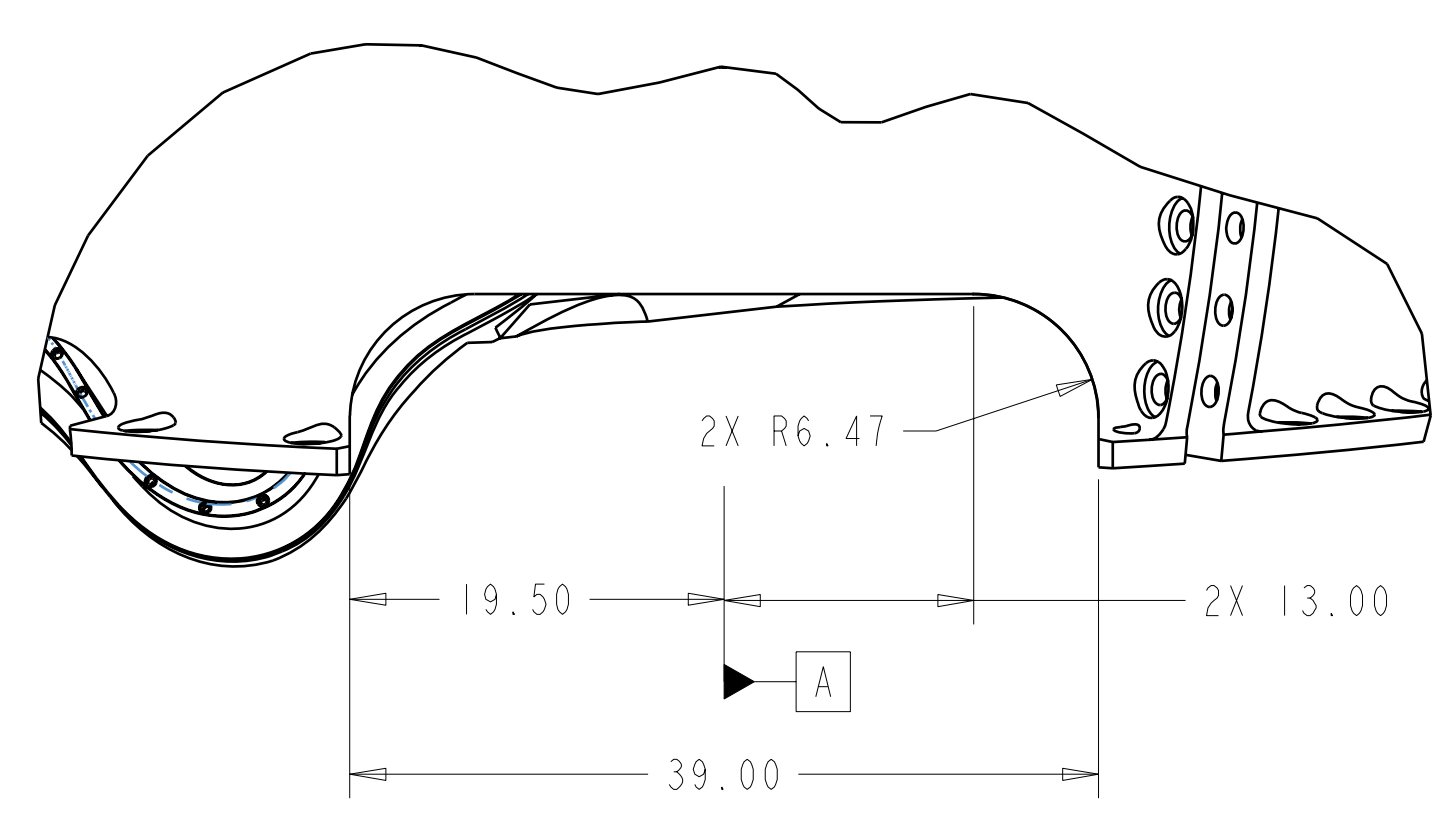

SECTION P7-P7
 SCALE 0.1

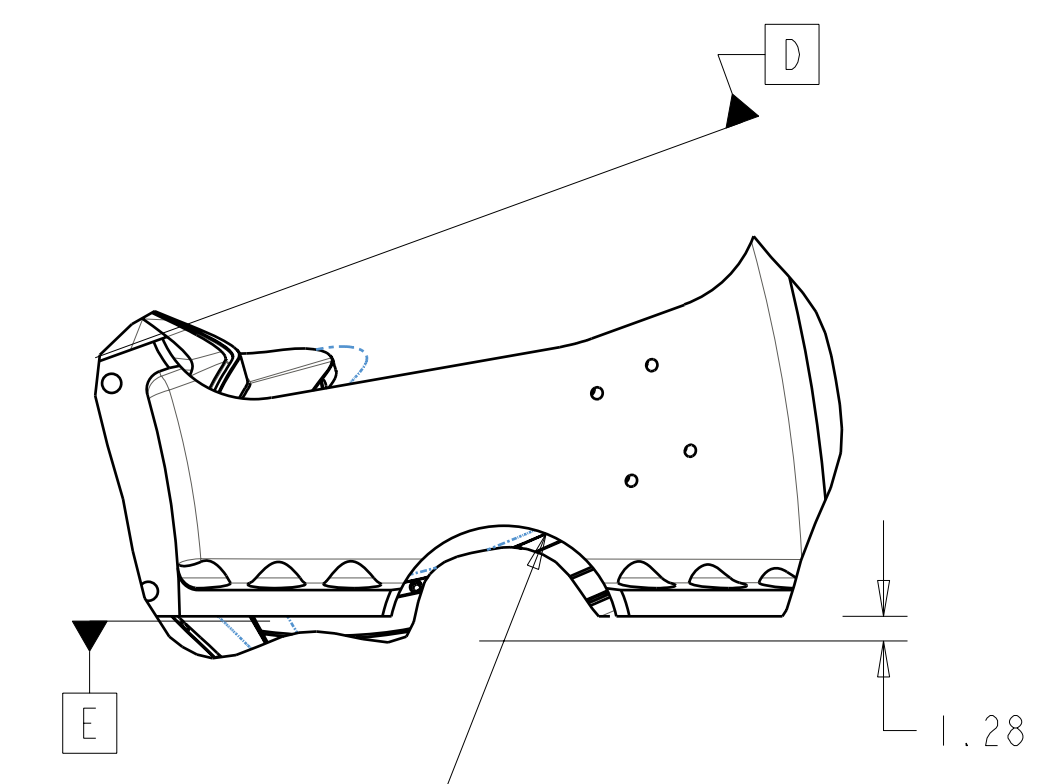

SOME FEATURES NOT SHOWN FOR CLARITY

RELEASED FOR FABRICATION / INSTALLATION
 PPPL Drafting:

Oak Ridge National Laboratory managed for the DEPARTMENT OF ENERGY under U.S. GOVERNMENT contract DE-AC05-00OR22725 UT-BATTELLE, LLC, Oak Ridge, Tennessee PROJECT NAME:								
UT-BATTELLE NATIONAL COMPACT STELLARATOR EXPERIMENT PRODUCTION WINDING FORM TYPE-A								
VERSION NO.	PLANT	BLDG	FL	SHT OF	TYPE	CLASS		
9	X-10	5700	3	8	11	S	U	
RELEASE LEVEL	SEI41-114						REV	3
Fabrication								

H
G
F
E
D
C
B
A
 SEI41-114

FOR NOTES AND PARTS LIST SEE SHEET 1

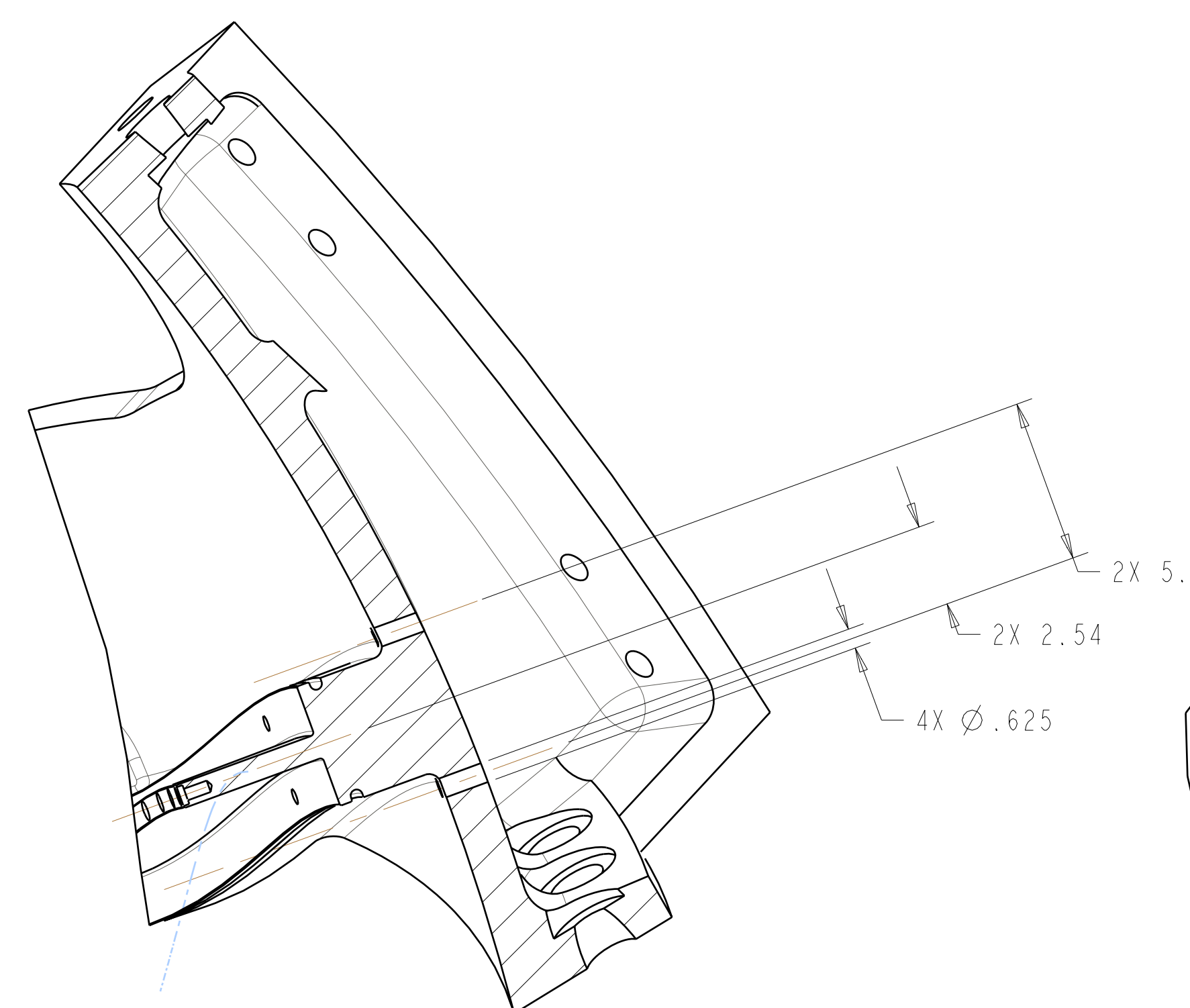

SECTION X-X

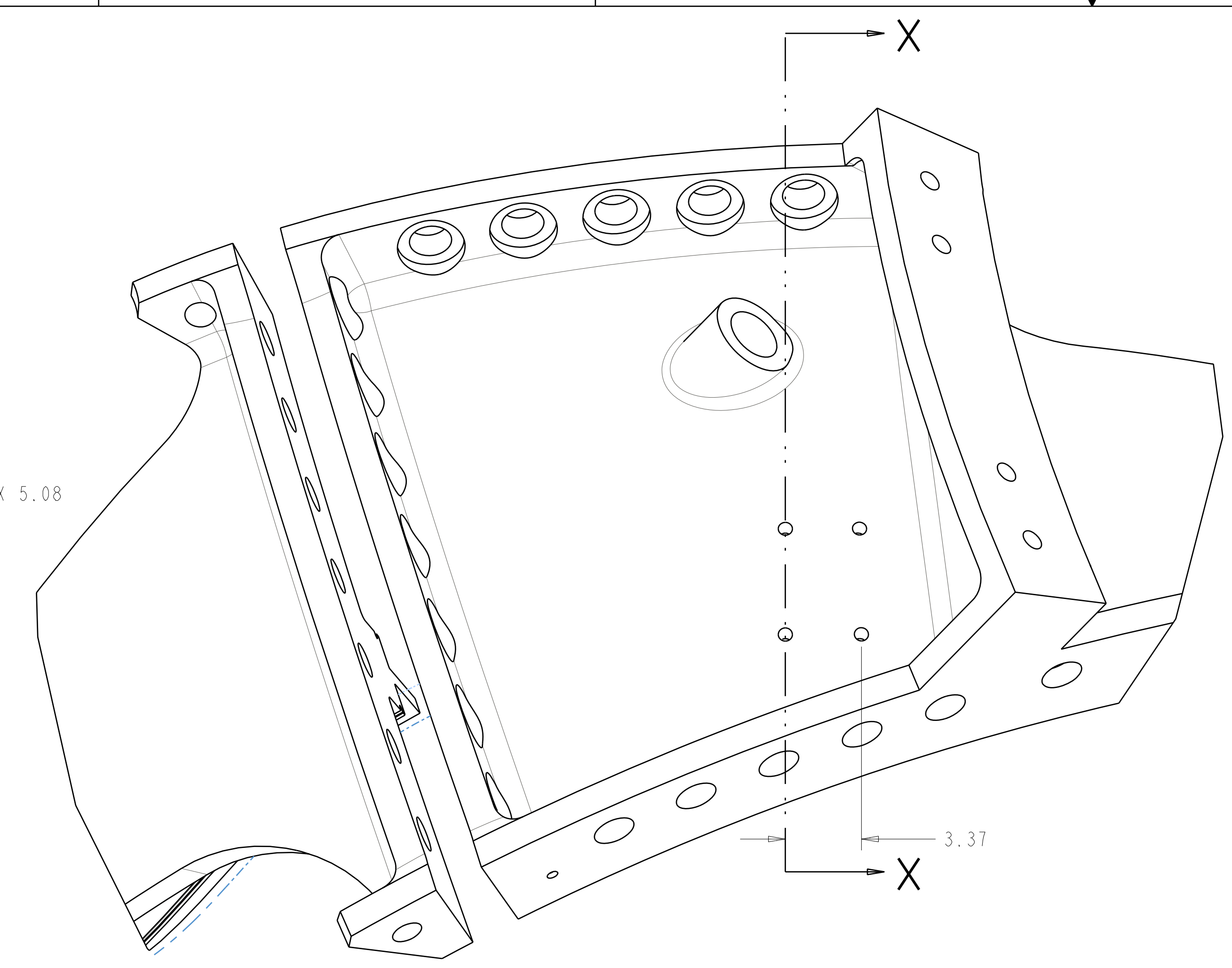

COOLING INLET / OUTLET HOLES
 TYPICAL 2 PLACES

SCALE 0.250
 USE PRO/E MODEL GEOMETRY TO
 DETERMINE SECTION ORIENTATION

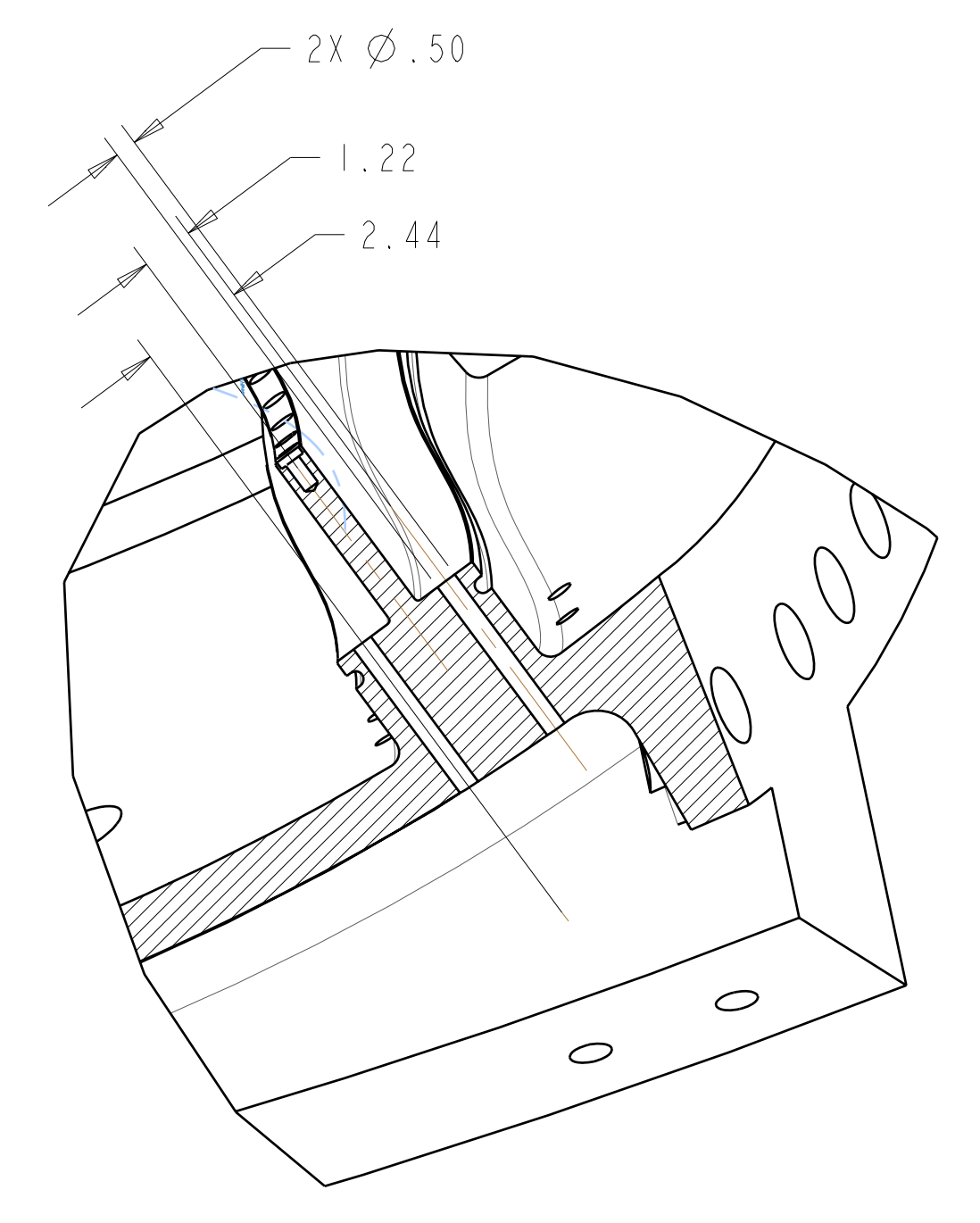

SECTION M-M

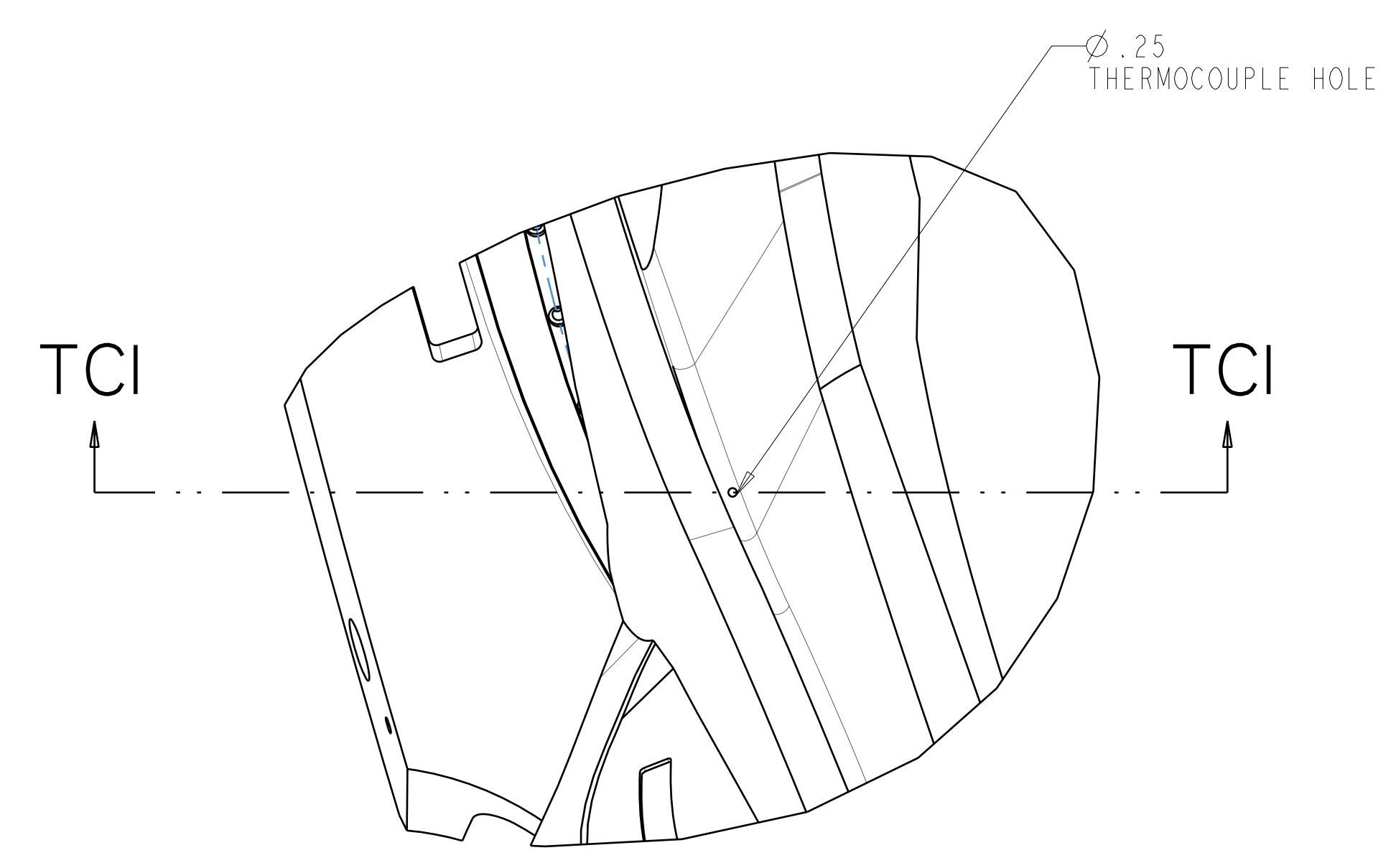

THERMOCOUPLE HOLE

SCALE 0.250
 USE PRO/E MODEL GEOMETRY TO
 DETERMINE SECTION ORIENTATION

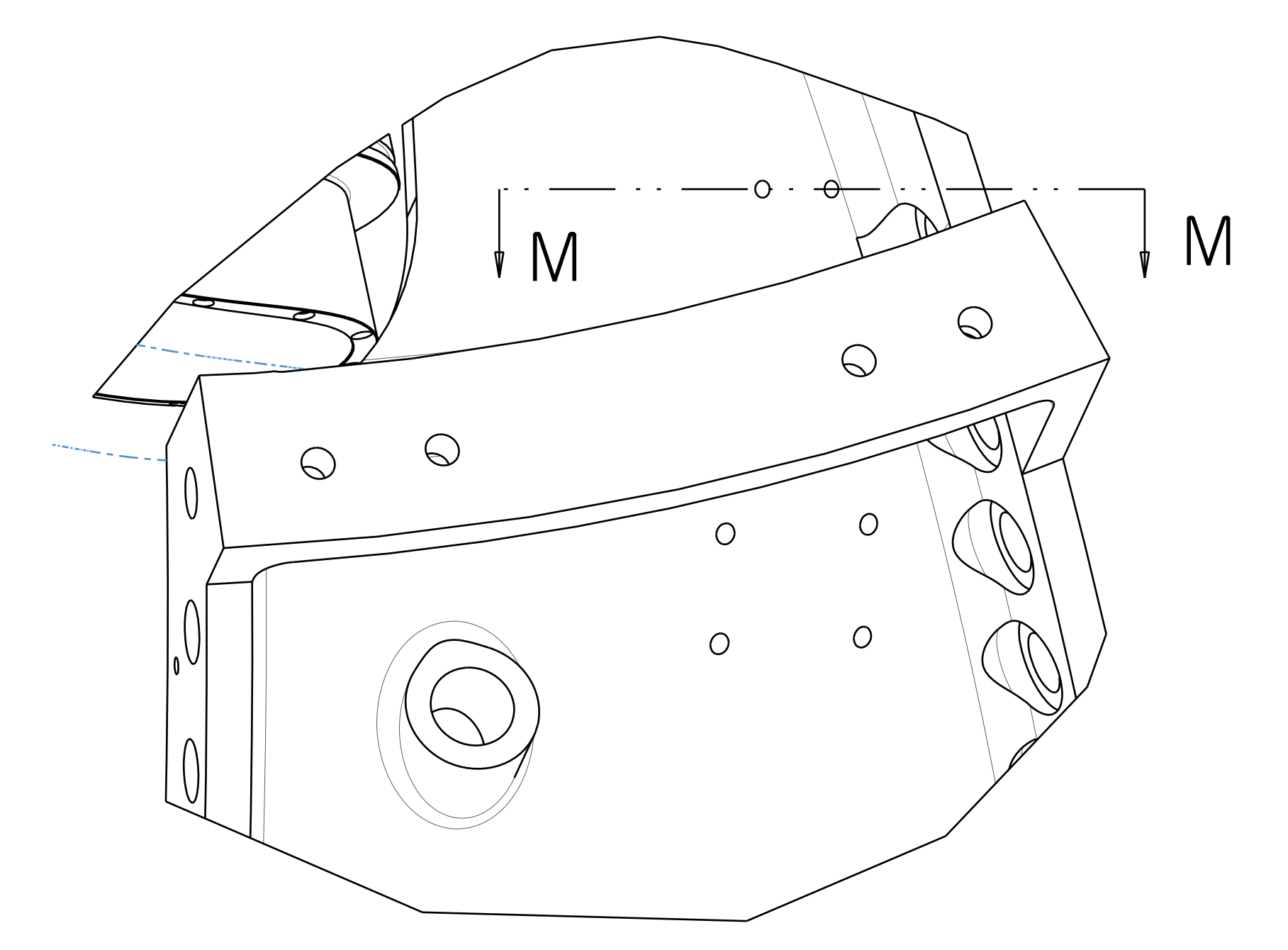

VPI BLEED HOLES

SCALE 0.250
 USE PRO/E MODEL GEOMETRY TO
 DETERMINE SECTION ORIENTATION

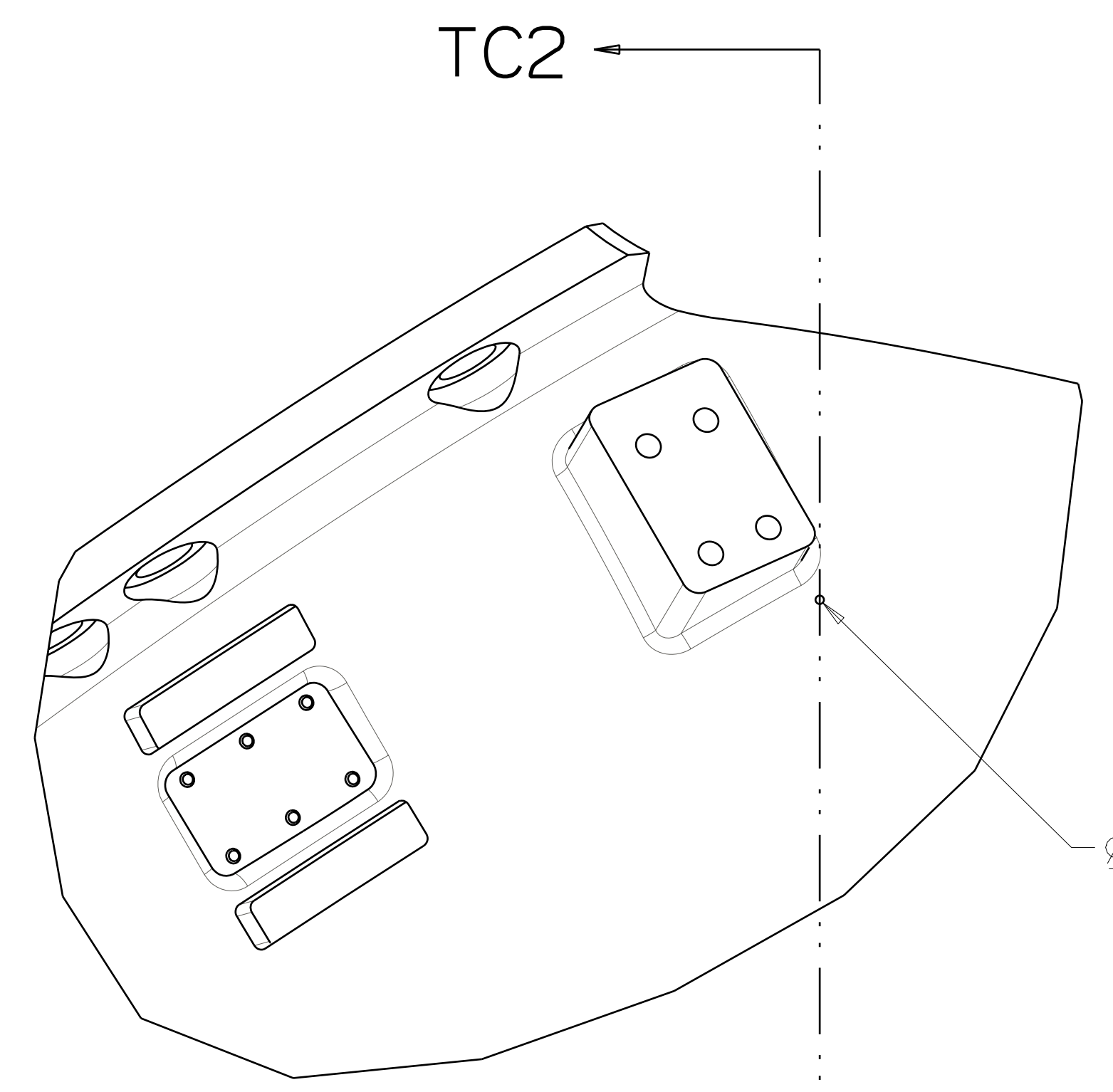

THERMOCOUPLE HOLE

SCALE 0.250
 USE PRO/E MODEL GEOMETRY TO
 DETERMINE SECTION ORIENTATION

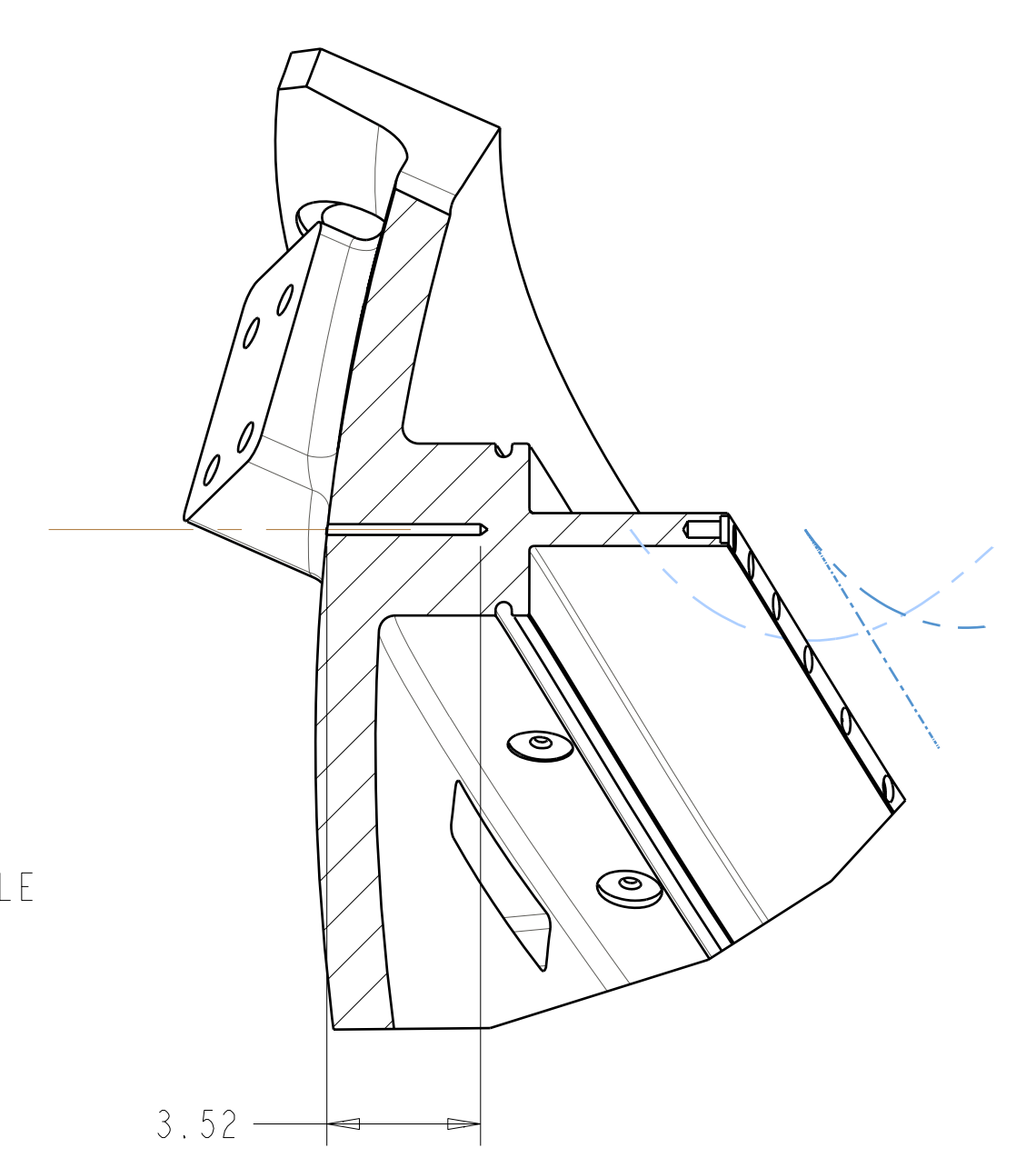

SECTION TC2-TC2

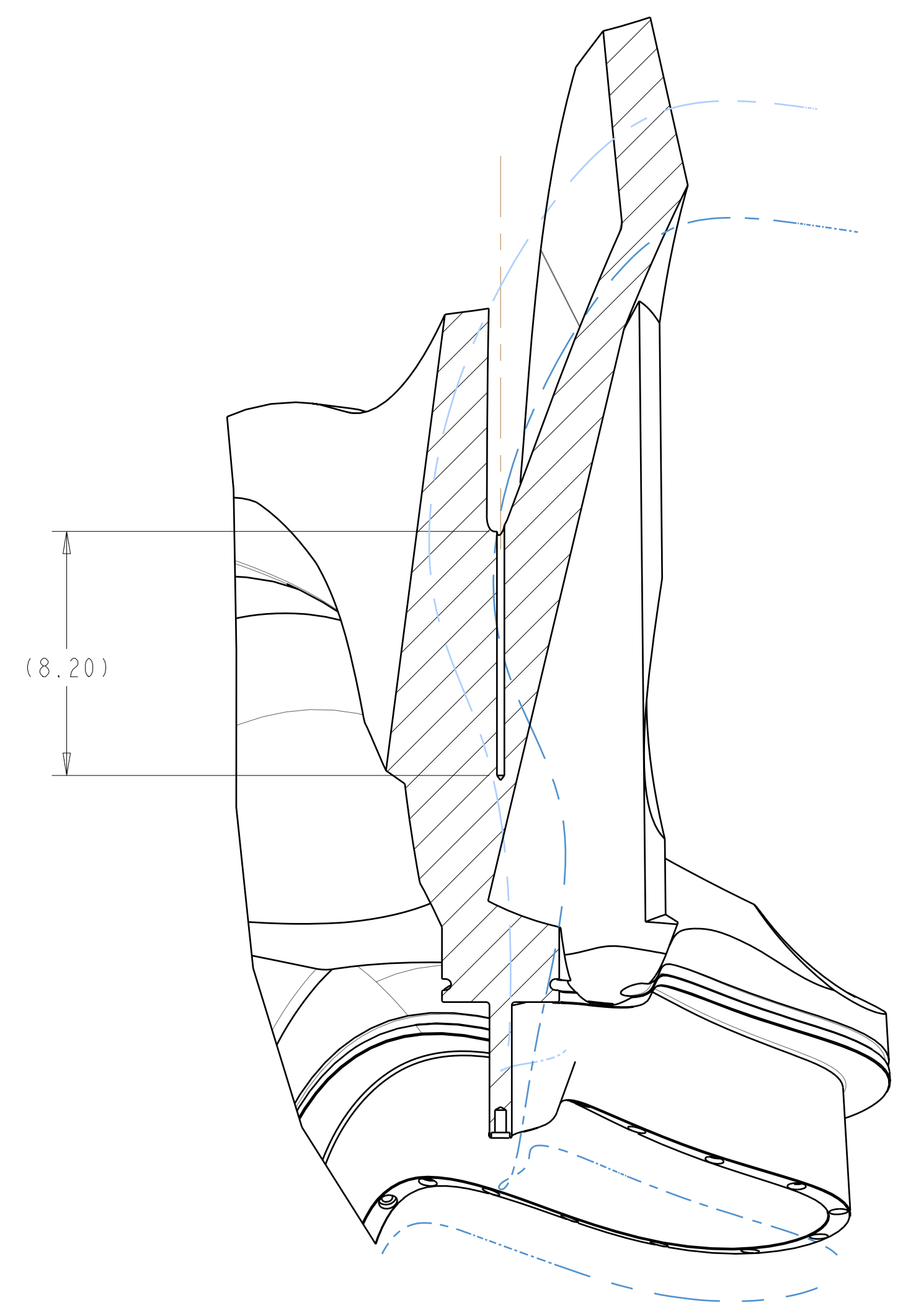

SECTION TCI-TCI

**RELEASED FOR
 FABRICATION / INSTALLATION**
 PPPL Drafting:

Oak Ridge National Laboratory managed for the DEPARTMENT OF ENERGY under U.S. GOVERNMENT contract DE-AC05-00OR22725 UT-BATTELLE, LLC, Oak Ridge, Tennessee PROJECT NAME							
NATIONAL COMPACT STELLARATOR EXPERIMENT							
PRODUCTION WINDING FORM TYPE-A							
VERSION NO.	PLANT	BLDG	FL	SHT OF	TYPE	CLASS	
9	X-10	5700	3	9	11	S	U
RELEASE LEVEL	SEI41-114						REV
Fabrication							3

H
G
F
E
D
C
B
A
 SEI41-114

FOR NOTES AND PARTS LIST SEE SHEET 1

AS CAST SURFACES





ISOMETRIC VIEW
 SURFACE COLOR INDICATES PROFILE TOLERANCE

MACHINED SURFACES



ISOMETRIC VIEW
 SURFACE COLOR INDICATES PROFILE TOLERANCE

WING SURFACES

**RELEASED FOR
 FABRICATION / INSTALLATION**
 PPPL Drafting:

Oak Ridge National Laboratory managed for the DEPARTMENT OF ENERGY under U.S. GOVERNMENT contract DE-AC05-00OR22725 UT-BATTELLE, LLC, Oak Ridge, Tennessee PROJECT NAME							
UT-BATTELLE NATIONAL COMPACT STELLARATOR EXPERIMENT							
PRODUCTION WINDING FORM TYPE-A							
VERSION NO.	PLANT	BLDG	FL	SHT OF	TYPE	CLASS	
9	X-10	5700	3	10	I	S	U
RELEASE LEVEL		SEI41-114				REV	
Fabrication						3	

SEI41-114

A

TABLE I WINDING CENTER SPLINE
(FILE SE141-114-WC.TXT)

#	X	Y	Z
1	93.704	20.083	0.000
2	93.186	20.519	2.792
3	92.772	20.359	5.631
4	92.411	19.752	8.420
5	91.980	18.928	11.143
6	91.359	18.070	13.819
7	90.485	17.285	16.444
8	89.340	16.628	19.001
9	87.928	16.150	21.461
10	86.261	15.912	23.792
11	84.375	15.934	25.964
12	82.325	16.167	27.969
13	80.158	16.505	29.832
14	77.905	16.825	31.594
15	75.582	17.065	33.276
16	73.192	17.212	34.873
17	70.730	17.308	36.361
18	68.193	17.397	37.715
19	65.580	17.512	38.916
20	62.898	17.668	39.946
21	60.157	17.849	40.806
22	57.371	17.995	41.510
23	54.552	18.014	42.091
24	51.726	17.800	42.582
25	48.934	17.254	43.006
26	46.232	16.334	43.355
27	43.645	15.095	43.586
28	41.140	13.681	43.623
29	38.665	12.234	43.382
30	36.249	10.786	42.800
31	34.052	9.194	41.853
32	32.377	7.280	40.530
33	31.358	5.076	38.993
34	30.569	2.810	37.403
35	29.795	0.777	35.526
36	29.277	-0.833	33.207
37	29.402	-2.032	30.606
38	30.230	-2.953	28.014
39	31.511	-3.679	25.543
40	33.033	-4.202	23.158
41	34.691	-4.481	20.824
42	36.427	-4.464	18.530
43	38.172	-4.076	16.278
44	39.813	-3.218	14.081
45	41.211	-1.864	11.965
46	42.470	-0.303	9.901
47	43.916	1.051	7.816
48	45.581	2.101	5.717
49	47.299	2.943	3.568
50	48.794	3.713	1.238
51	49.453	4.460	-1.436
52	48.785	5.121	-4.136
53	47.556	6.198	-6.496
54	46.340	7.724	-8.611
55	45.082	9.224	-10.719
56	43.678	10.375	-12.949
57	42.246	11.314	-15.262
58	41.177	12.649	-17.558
59	40.918	14.793	-19.421
60	41.242	17.426	-20.513
61	41.544	20.191	-21.244
62	41.445	22.600	-22.749
63	41.139	23.705	-25.337
64	40.840	23.136	-28.105
65	40.376	21.385	-30.321
66	39.551	19.145	-31.916
67	38.434	16.821	-33.195
68	37.307	14.646	-34.696
69	36.731	12.854	-36.839
70	37.542	11.788	-39.331
71	39.637	11.463	-41.240
72	42.252	11.515	-42.423
73	45.038	11.685	-43.118
74	47.886	11.849	-43.490
75	50.758	11.951	-43.630
76	53.636	11.976	-43.582
77	56.505	11.936	-43.359
78	59.353	11.842	-42.963
79	62.170	11.666	-42.399
80	64.938	11.351	-41.679
81	67.639	10.861	-40.818
82	70.259	10.218	-39.816
83	72.798	9.505	-38.664
84	75.263	8.822	-37.345
85	77.655	8.246	-35.853
86	79.966	7.812	-34.195
87	82.189	7.521	-32.391
88	84.320	7.361	-30.464
89	86.356	7.322	-28.430
90	88.287	7.414	-26.299
91	90.094	7.670	-24.074
92	91.741	8.139	-21.762
93	93.169	8.867	-19.375
94	94.305	9.895	-16.941
95	95.074	11.227	-14.512
96	95.448	12.801	-12.135
97	95.465	14.506	-9.819
98	95.213	16.214	-7.517
99	94.793	17.787	-5.144
100	94.269	19.118	-2.648
101	93.704	20.083	0.000

TABLE II X-VECTOR SPLINE
(FILE SE141-114-XV.TXT)

#	X	Y	Z
1	90.227	18.098	0.000
2	89.756	18.455	2.581
3	89.381	18.256	5.197
4	89.044	17.665	7.760
5	88.623	16.899	10.265
6	88.013	16.122	12.726
7	87.159	15.424	15.139
8	86.053	14.856	17.481
9	84.700	14.465	19.728
10	83.118	14.302	21.849
11	81.346	14.375	23.820
12	79.433	14.626	25.641
13	77.420	14.954	27.338
14	75.332	15.257	28.947
15	73.182	15.477	30.486
16	70.970	15.618	31.945
17	68.693	15.715	33.303
18	66.347	15.807	34.538
19	63.933	15.922	35.631
20	61.456	16.075	36.569
21	58.926	16.246	37.351
22	56.355	16.378	37.991
23	53.756	16.382	38.523
24	51.156	16.144	38.987
25	48.601	15.570	39.402
26	46.149	14.626	39.754
27	43.820	13.381	39.993
28	41.566	11.983	40.038
29	39.341	10.560	39.801
30	37.219	9.084	39.215
31	35.546	7.303	38.222
32	34.664	5.179	36.910
33	33.996	3.016	35.526
34	33.343	1.057	33.867
35	33.048	-0.463	31.733
36	33.669	-1.500	29.386
37	34.662	-2.253	27.142
38	36.292	-2.780	24.972
39	37.641	-3.053	22.837
40	39.449	-3.024	20.728
41	41.030	-2.584	18.648
42	42.470	-1.659	16.627
43	43.677	-0.303	14.695
44	44.777	1.205	12.809
45	46.095	2.448	10.879
46	47.728	3.096	8.897
47	49.464	3.368	6.910
48	51.127	3.542	4.851
49	52.492	3.882	2.607
50	53.305	4.392	0.141
51	53.375	4.944	-2.443
52	52.722	5.473	-4.953
53	51.613	6.092	-7.280
54	50.394	7.039	-9.436
55	49.180	8.148	-11.518
56	47.903	9.134	-13.624
57	46.547	9.919	-15.765
58	45.268	10.858	-17.885
59	44.561	12.594	-19.711
60	44.736	15.028	-20.701
61	45.198	17.612	-21.075
62	45.501	20.214	-21.468
63	45.464	22.561	-22.650
64	45.196	23.921	-24.869
65	44.910	23.883	-27.475
66	44.587	22.666	-29.791
67	44.076	20.820	-31.617
68	43.308	18.690	-32.993
69	42.315	16.477	-34.066
70	41.230	14.317	-35.157
71	40.530	12.362	-36.760
72	42.301	11.550	-38.345
73	44.818	11.415	-39.156
74	47.436	11.365	-39.575
75	50.082	11.302	-39.750
76	52.733	11.201	-39.742
77	55.378	11.074	-39.572
78	58.007	10.940	-39.244
79	60.612	10.789	-38.760
80	63.175	10.532	-38.129
81	65.680	10.115	-37.363
82	68.111	9.545	-36.467
83	70.465	8.892	-35.432
84	72.750	8.249	-34.246
85	74.967	7.695	-32.899
86	77.112	7.267	-31.398
87	79.177	6.973	-29.760
88	81.160	6.800	-28.005
89	83.056	6.736	-26.151
90	84.862	6.787	-24.208
91	86.561	6.977	-22.180
92	88.124	7.349	-20.070
93	89.502	7.949	-17.885
94	90.623	8.824	-15.648
95	91.405	9.996	-13.404
96	91.800	11.419	-11.203
97	91.841	12.984	-9.063
98	91.617	14.559	-6.940
99	91.231	16.010	-4.753
100	90.747	17.230	-2.449
101	90.227	18.098	0.000

ALL POINT LOCATIONS ARE BASIC
FOR NOTES AND PARTS LIST SEE SHEET I

**RELEASED FOR
FABRICATION / INSTALLATION**
PPPL Drafting:

Oak Ridge National Laboratory
managed for the DEPARTMENT OF ENERGY under
U.S. GOVERNMENT contract DE-AC05-00OR22725
UT-BATTELLE, LLC. Oak Ridge, Tennessee

UT-BATTELLE

NATIONAL COMPACT STELLARATOR EXPERIMENT

PRODUCTION WINDING FORM TYPE-A

VERSION NO.	PLANT	BLDG	FL	SHT OF	TYPE	CLASS
9	X-10	5700	3	11 11	S	U
RELEASE LEVEL	SE141-114					REV
Fabrication						3