

ISOMETRIC VIEW

NOTES:

1. DRAWING PREPARED IN ACCORDANCE WITH ASME Y14.8M-1996.
2. INTERPRET DIMENSIONS AND TOLERANCES PER ANSI Y14.5M-1994.
3. DIMENSIONS ARE IN INCHES.
4. DRAWING DEPICTS FINAL MACHINED STATE OF PART DEFINED BY PRO/ENGINEER FILE SE141-116.PRT.
5. UNLESS OTHERWISE SPECIFIED, DIMENSIONS ARE RELATED TO DATUM A - (PRIMARY X-Y PLANE, TOP)
 DATUM B - (SECONDARY Y-Z PLANE, SIDE)
 DATUM C - (TERTIARY X-Z PLANE, FRONT)
6. DIMENSIONS APPLY AT TEMPERATURE OF 20-30°C (68-86°F)
7. DIMENSIONS AND TOLERANCES EXCLUDE PROCESS MATERIAL ALLOWANCES WHICH MAY ADD MASS.
8. APPROXIMATE WEIGHT = 4898 LBS.
 WEIGHT OF FINISHED PART NOT TO EXCEED 6000 LBS.
9. UNLESS OTHERWISE SPECIFIED, AS-CAST SURFACE PROFILE TOLERANCE = $\pm .25$ INCH, WITH EXEMPTION FOR INTERSECTING SURFACES WHERE FILLETS ARE EXPECTED. MIN FILLET AND CORNER RADII = $0.5 \pm .1$ IN.
10. DESIGNATED SURFACE REGIONS HAVE PROFILE TOLERANCE = ± 0.125 IN.
11. MIN THICKNESS PER CAD GEOMETRY, TOLERANCE = ± 0.25 IN / -0.0 IN.
12. PARTING LINE EDGES, FLASH, GATES, RUNNER, AND RISER EXTENSIONS 0.25 IN MAX
13. UNLESS OTHERWISE SPECIFIED, MACHINED SURFACE PROFILE TOLERANCE = ± 0.01 IN.
14. BACK SPOTFACE ALL THRU HOLES MINIMUM TO CLEAN UP.
15. SEE LATEST REVISION OF SPECIFICATION NCSX-CSPEC-141-03 FOR ADDITIONAL REQUIREMENTS.

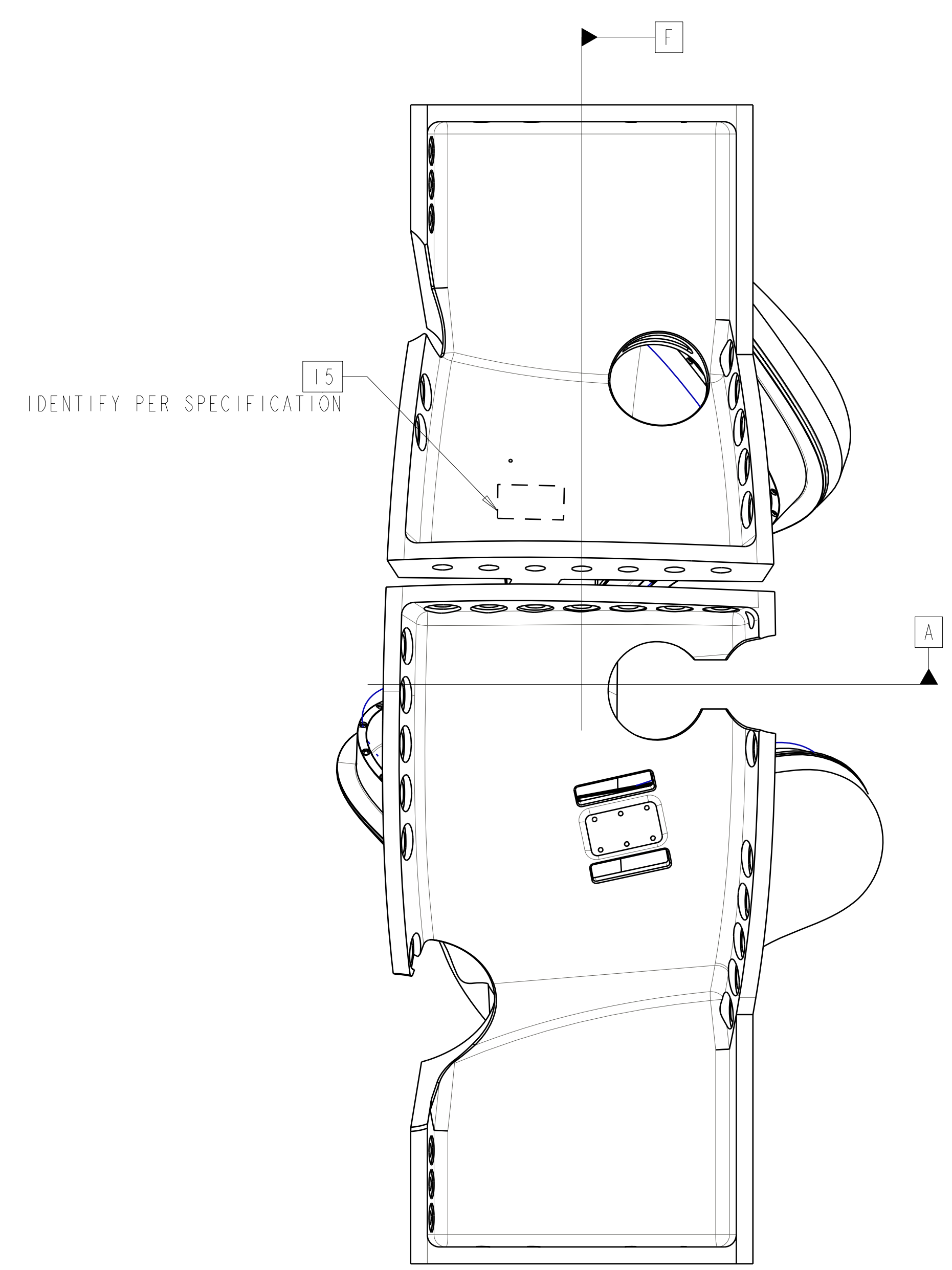
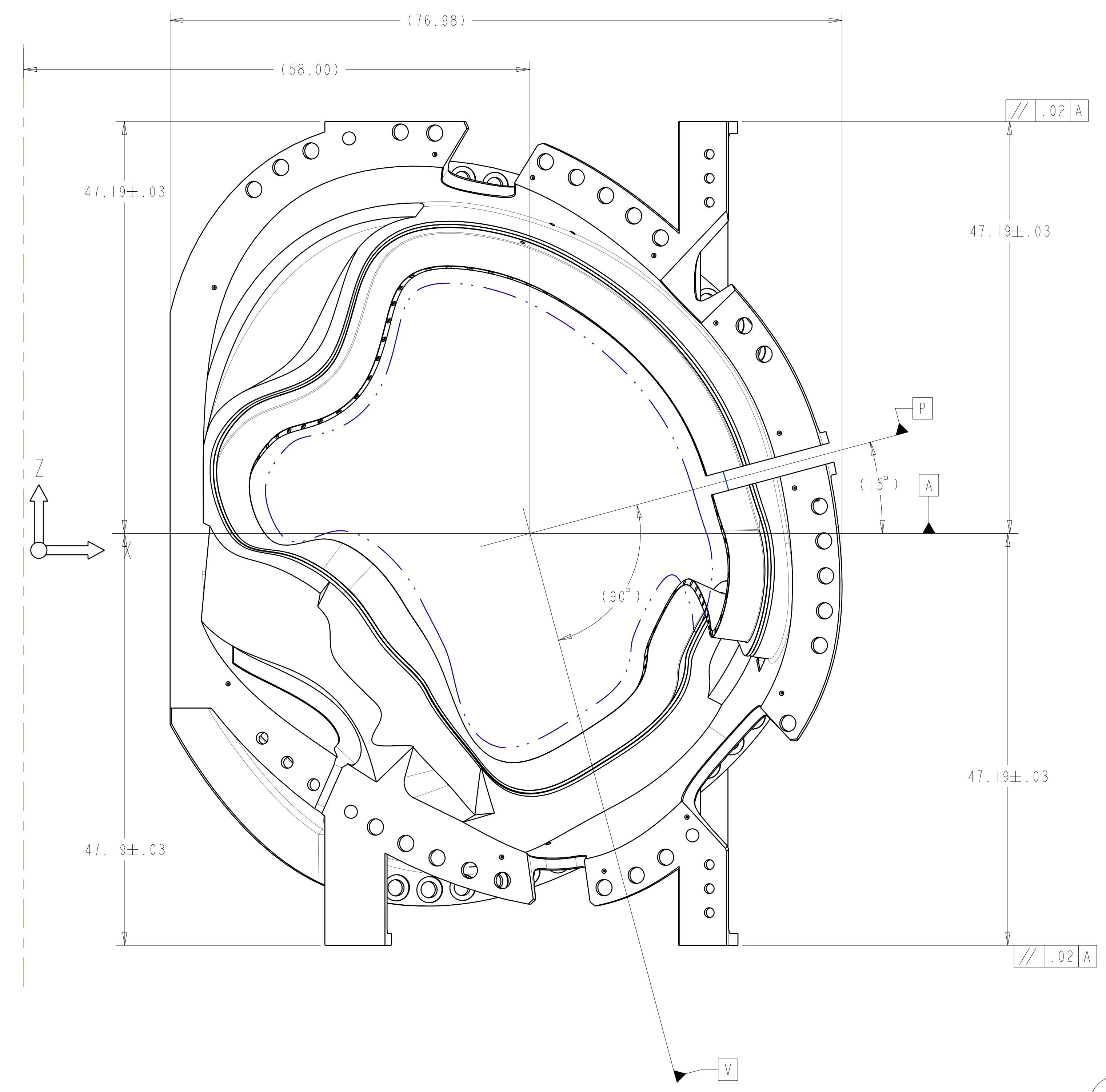

**RELEASED FOR
 FABRICATION / INSTALLATION**
 PPPL Drafting:

AR	X	SE141-116	WINDING FORM TYPE-C	CAST SS	SEE NOTE #15	I
CAGE CODE	PART OR IDENTIFYING NO	NOMENCLATURE OR DESCRIPTION	MATERIAL	SPECIFICATION	FIND NO	
		NEXT ASSEMBLY	PARTS LIST			

SCALE .125

REV	DESCRIPTION	BY	DATE	CHK	DEPT	DATE	PE	REG	DATE	ORNL	DOE	DATE
4	REVISED DRAWING AND MODEL PER ECN 4965	GLL	3-05	MJC			DEW					
3	REVISED DRAWING AND MODEL PER ECN 4944	GLL	1/05	MJC			DEW					
2	SHEET 11 REMOVED TABLES III & IV	GLL	9/04	MJC			DEW					
1	SHEET 2; DETAIL B REMOVED SPHERICAL SEATS MODIFIED TEE RELIEF TO .1 R; .03 CHAMFER WAS .06 PER ECN 4903											
1	REVERSED UPPER INB VERT SUPP POCKET. CHANGED LN2 INLET/OUTLET HOLE DIAMETER. MODIFIED LEAD BLOCK DIMS PER ECN-4883.	DEW	7/04	TGB			DEW					

SCALE NOTED		DES	T BROWN	5-5-04
TOLERANCES UNLESS OTHERWISE SPECIFIED		DRW	P MILLER	5-5-04
FRACTIONS		CHK	M. COLE	6-25-04
XX DECIMALS ± .04		SECT		
XXX DECIMALS ± .005		DEPT		
ANGLES ± 0'15"		PE	D. WILLIAMSON	6-25-04
BREAK SHARP EDGES .06 MAX		CR		
FINISH .125 UNLESS OTHERWISE SPECIFIED		PJ		
		RED		
		PPPL DRFT	J. SIEGEL	6-25-04

UT-BATTELLE		Oak Ridge National Laboratory managed for the DEPARTMENT OF ENERGY under U.S. GOVERNMENT contract DE-AC05-00OR22725 UT-BATTELLE, LLC, Oak Ridge, Tennessee	
NATIONAL COMPACT STELLARATOR EXPERIMENT			
PRODUCTION WINDING FORM TYPE-C			
VERSION NO.	PLANT	BLDG	FL
10	X-10	5700	3
RELEASE LEVEL	Fabrication		
SEI41-116			
REV 4			

NO REPRESENTATION OR WARRANTY, EXPRESSED OR IMPLIED, IS MADE AS TO THE ACCURACY, COMPLETENESS OR USEFULNESS OF THE INFORMATION OR STATEMENTS CONTAINED IN THESE DRAWINGS, OR THAT THE USE OR DISCLOSURE OF ANY INFORMATION, APPARATUS, METHOD OR PROCESS DISCLOSED IN THESE DRAWINGS MAY NOT INFRINGE PRIVATE RIGHTS OF OTHERS. NO LIABILITY IS ASSUMED WITH RESPECT TO THE USE OF, OR FOR DAMAGES RESULTING FROM THE USE OF, ANY INFORMATION, APPARATUS, METHOD OR PROCESS DISCLOSED IN THESE DRAWINGS. DRAWINGS MADE AVAILABLE FOR INFORMATION TO BIDDER ARE NOT TO BE USED FOR OTHER PURPOSES, AND ARE TO BE RETURNED UPON REQUEST OF THE FORWARDING CONTRACTOR.

P THIS DRAWING PRODUCED ON PRO-ENGINEER

H
G
F
E
D
C
B
A

FOR NOTES AND PARTS LIST SEE SHEET 1

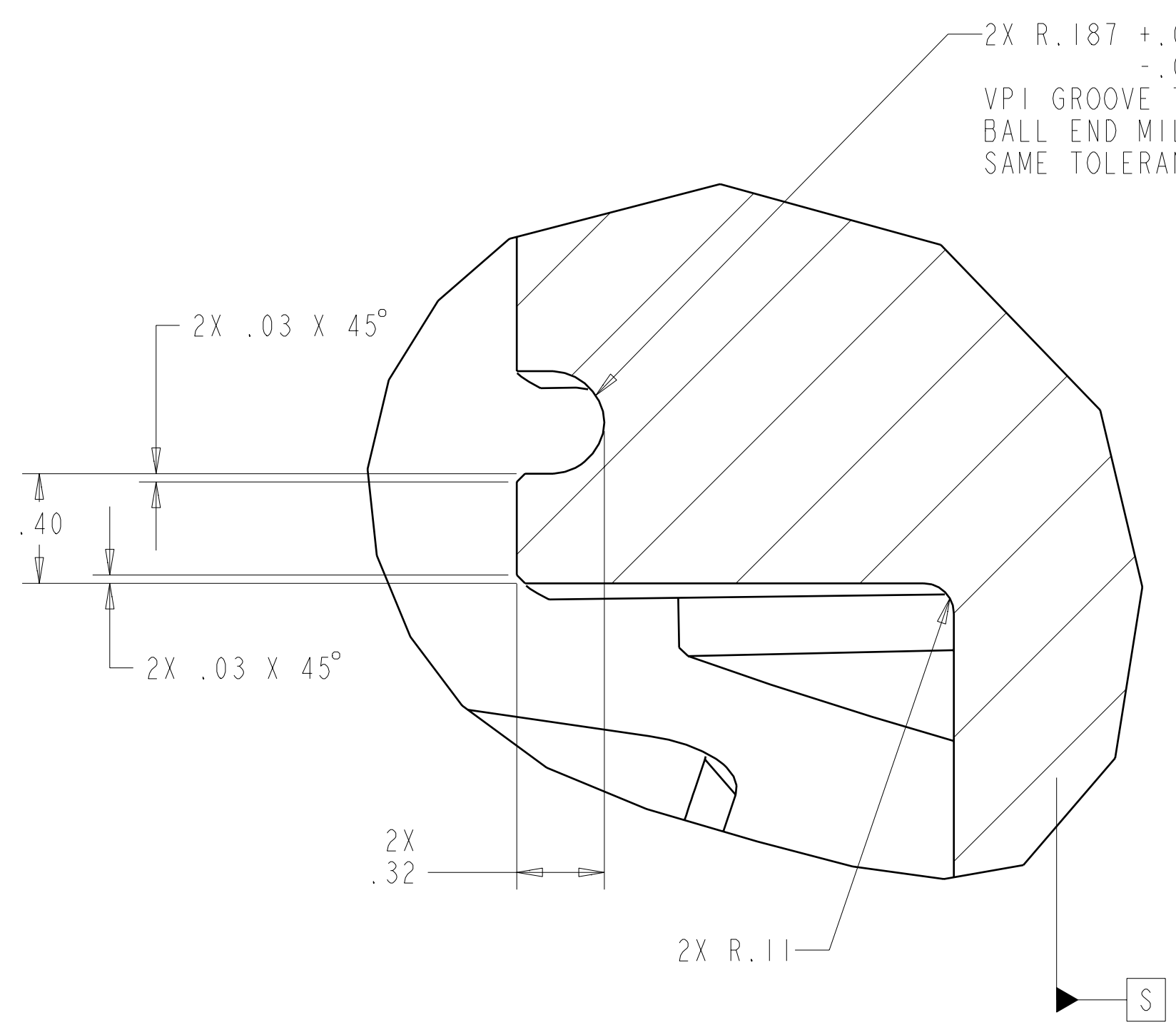

DETAIL B
SCALE 2.000

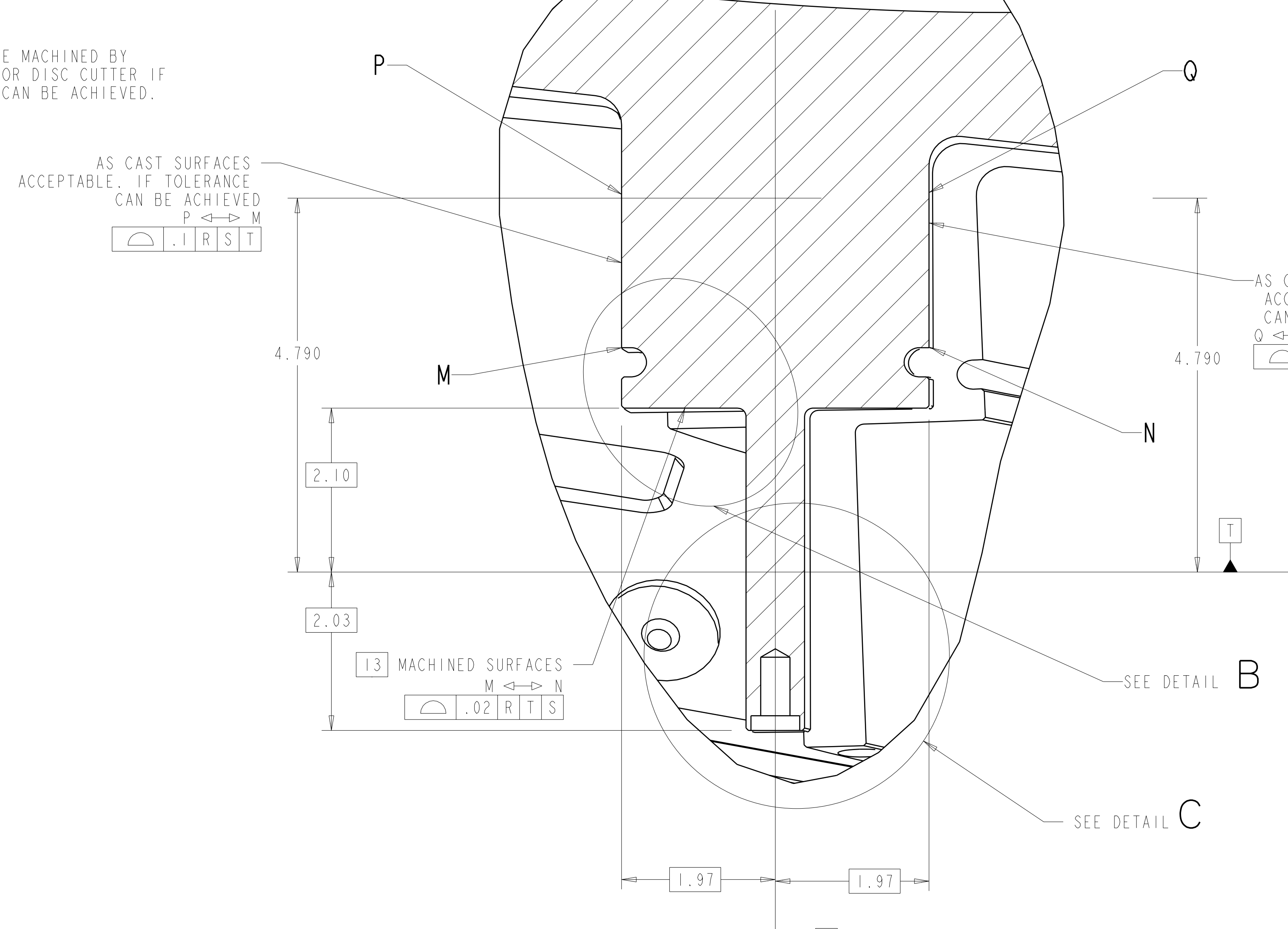

DETAIL A
SCALE 1.00

TYPICAL FOR ALL POINTS ALONG WINDING CENTER

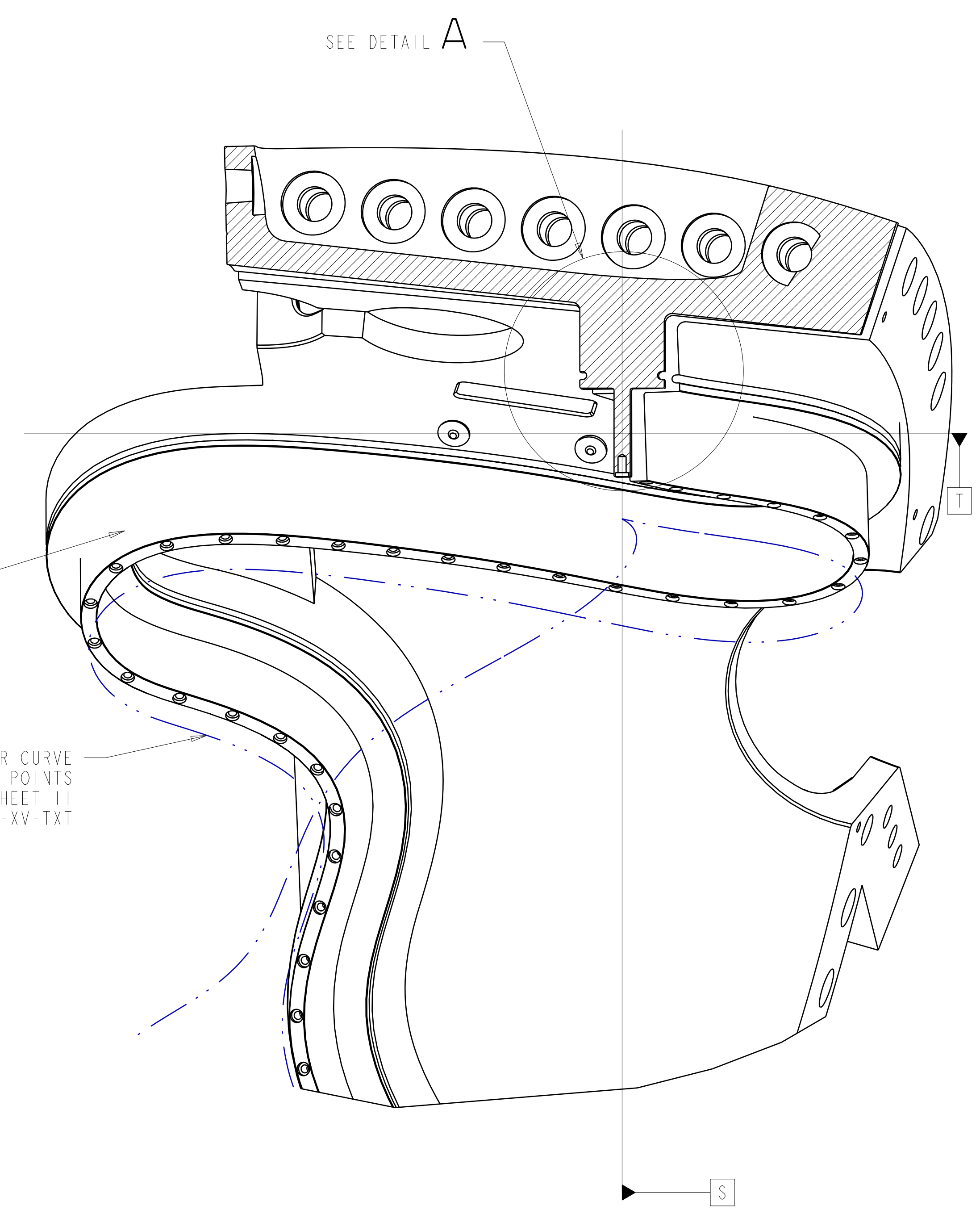

SECTION R-R
SCALE 0.25

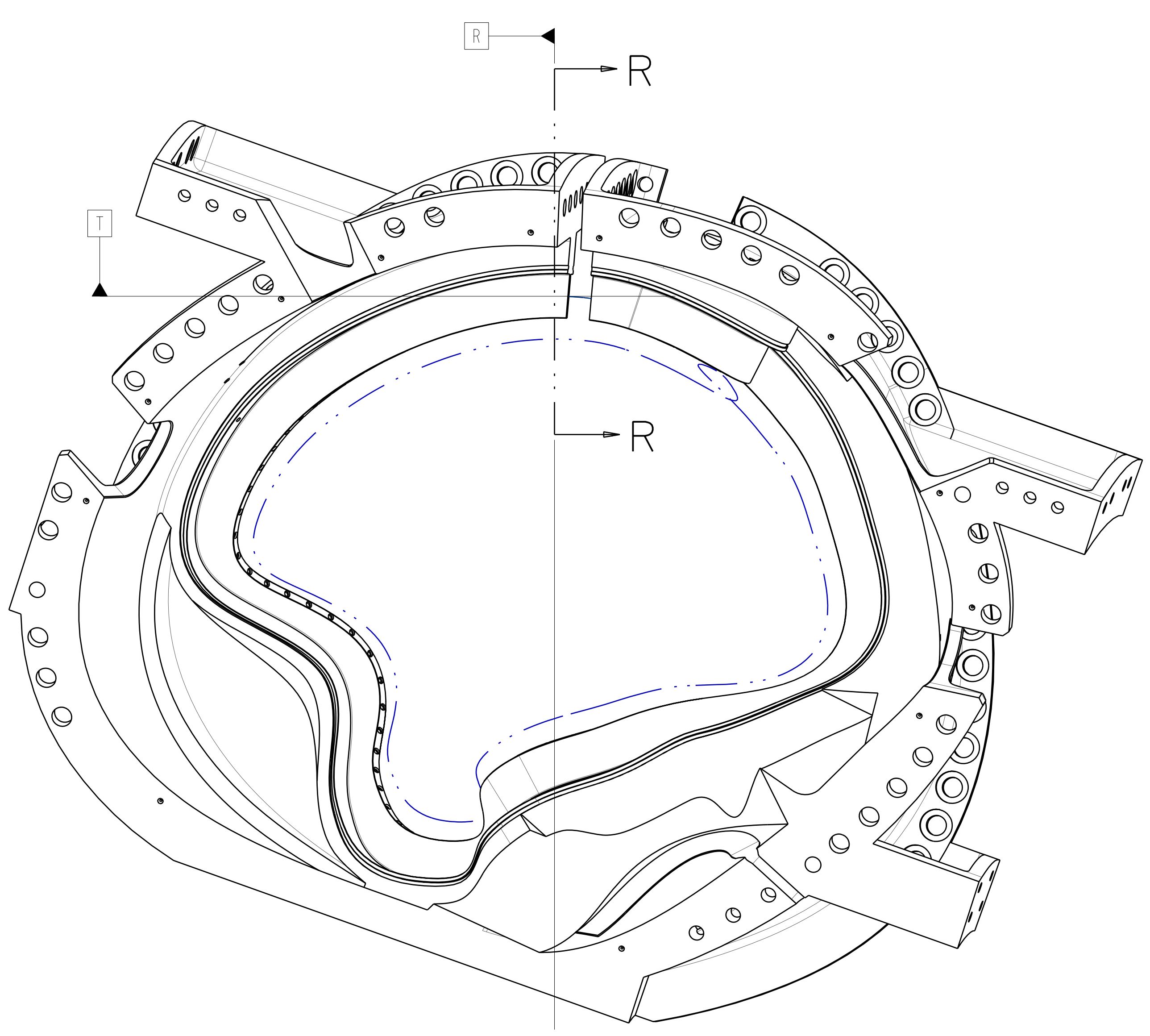

DATUM R = PLANE NORMAL TO WINDING CENTER
 DATUM S = PLANE PASSING THRU WINDING CENTER AND X VECTOR AT DATUM R
 DATUM T = PLANE PASSING THRU WINDING CENTER ORTHOGONAL TO DATUM S

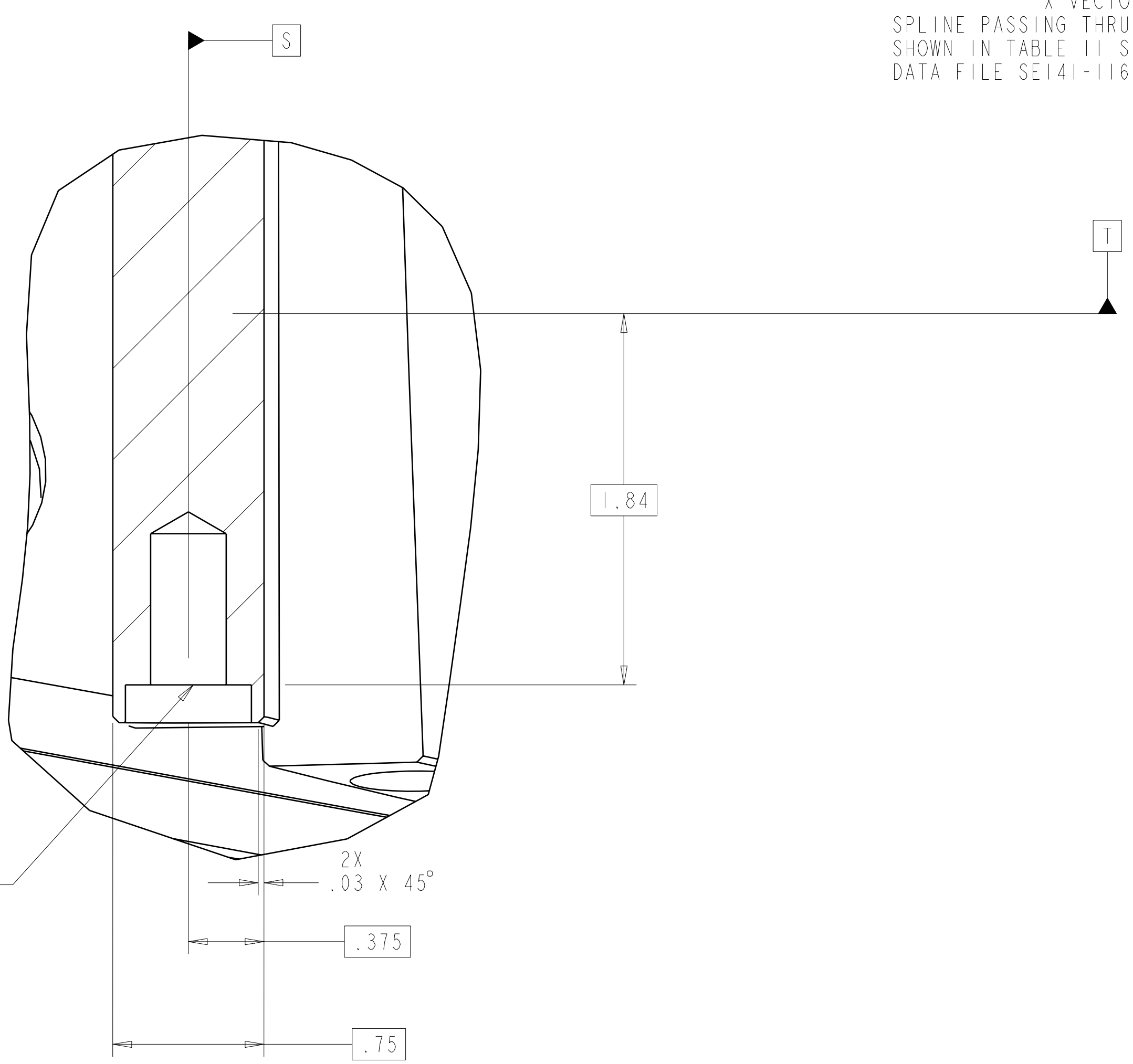

DETAIL C
SCALE 2.00

3 4
 96X
 Ø.375 -16 UNC Ψ.750
 .625 Ψ.188
 .01 R S T
 TRUE POSITION APPLIES
 TO DEPTH OF COUNTERSINK
 THREADED HOLE DEPTH +.1/-0

**RELEASED FOR
 FABRICATION / INSTALLATION**
 PPPL Drafting:

Oak Ridge National Laboratory managed for the DEPARTMENT OF ENERGY under U.S. GOVERNMENT contract DE-AC05-00OR22725 UT-BATTELLE, LLC, Oak Ridge, Tennessee PROJECT NAME							
UT-BATTELLE NATIONAL COMPACT STELLARATOR EXPERIMENT							
PRODUCTION WINDING FORM TYPE-C							
VERSION NO.	PLANT	BLDG	FL	SHT OF	TYPE	CLASS	
10	X-10	5700	3	2	11	S	U
RELEASE LEVEL	SEI41-116						REV
Fabrication							4

H
G
F
E
D
C
B
A

FOR NOTES AND PARTS LIST SEE SHEET 1

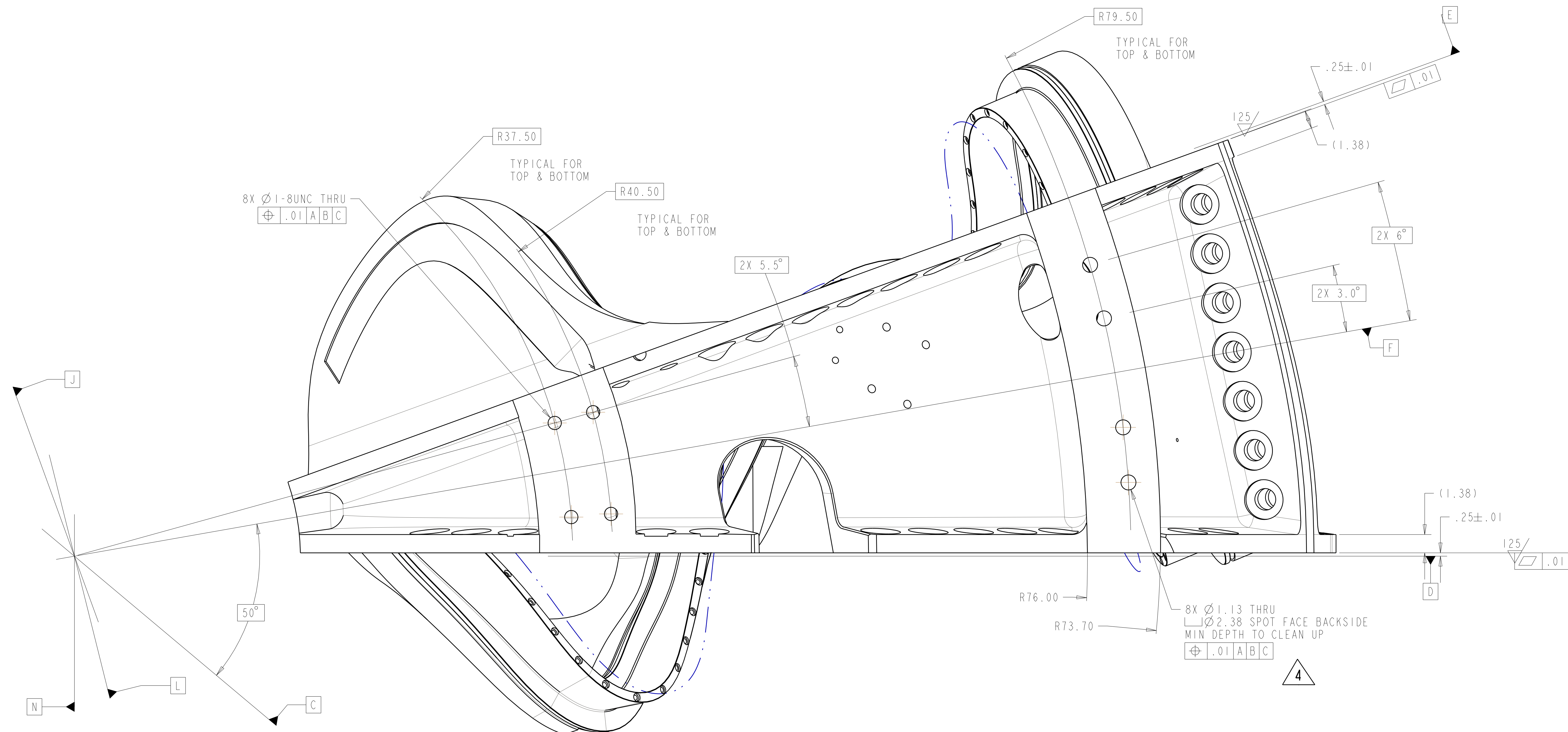

TOP VIEW
SCALE 0.25

DATUMS A B & C ARE MACHINE SPECIFIC.
ALL OTHER DATUMS LISTED ON THIS DRAWING
ARE SPECIFIC TO THIS PART

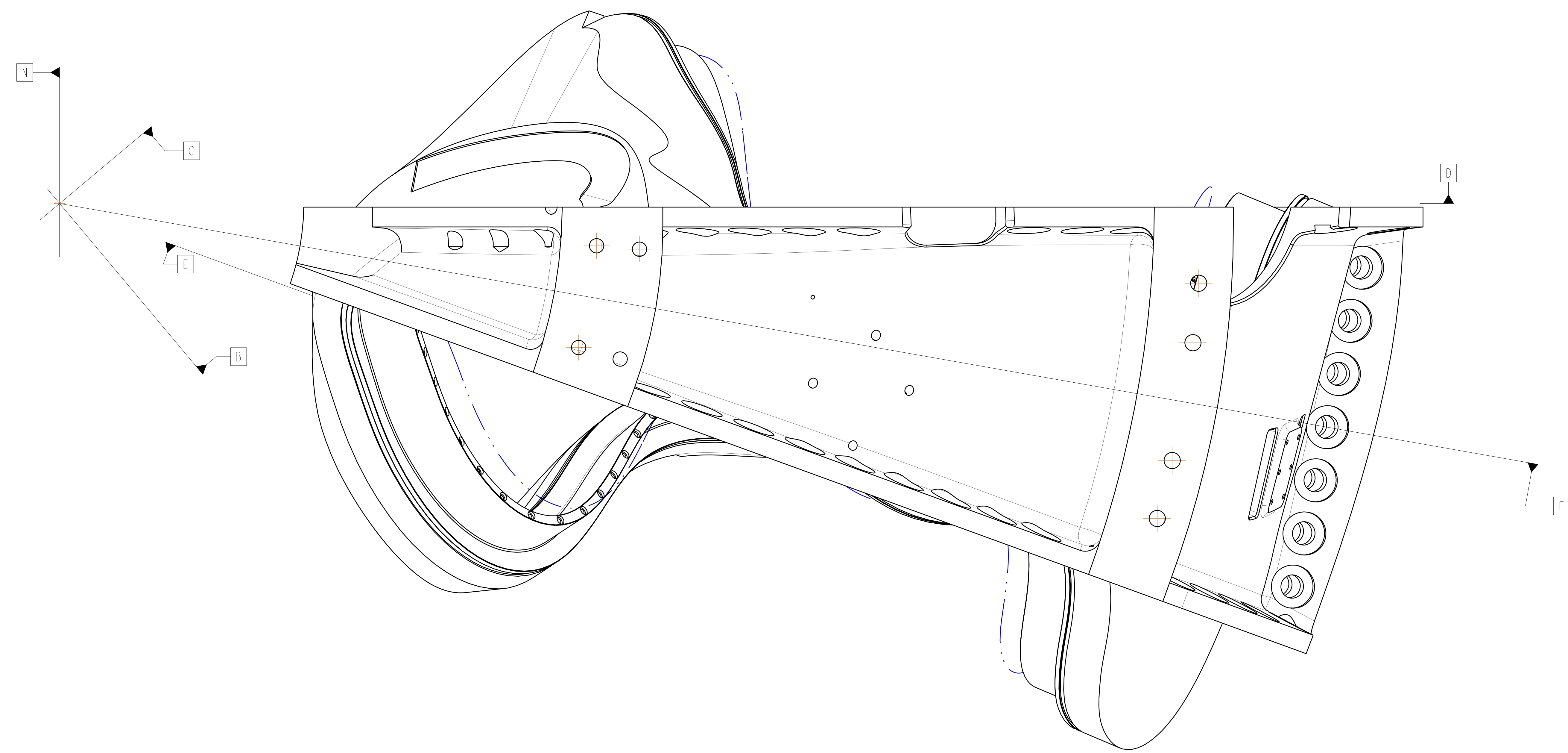

BOTTOM VIEW
SCALE 0.25

**RELEASED FOR
FABRICATION / INSTALLATION**
PPPL Drafting:

Oak Ridge National Laboratory managed for the DEPARTMENT OF ENERGY under U.S. GOVERNMENT contract DE-AC05-00OR22725 UT-BATTELLE, LLC, Oak Ridge, Tennessee PROJECT NAME							
UT-BATTELLE NATIONAL COMPACT STELLARATOR EXPERIMENT							
PRODUCTION WINDING FORM TYPE-C							
VERSION NO.	PLANT	BLDG	FL	SHT OF	TYPE	CLASS	
10	X-10	5700	3	3	11	S	U
RELEASE LEVEL	SEI41-116						REV
Fabrication							4

SEI41-116

A

FOR NOTES AND PARTS LIST SEE SHEET 1

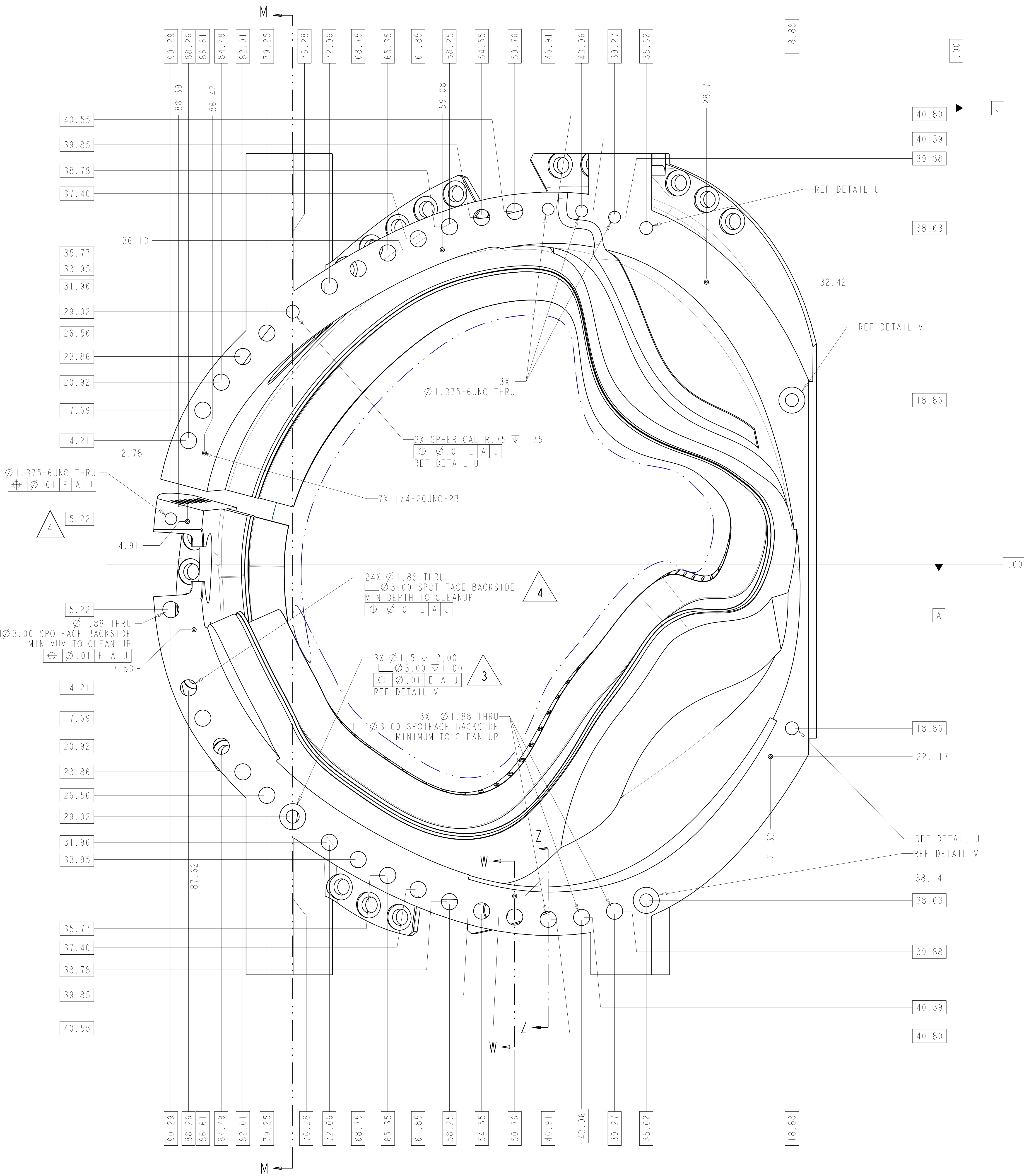

VIEW AT DATUM E
SCALE 0.20

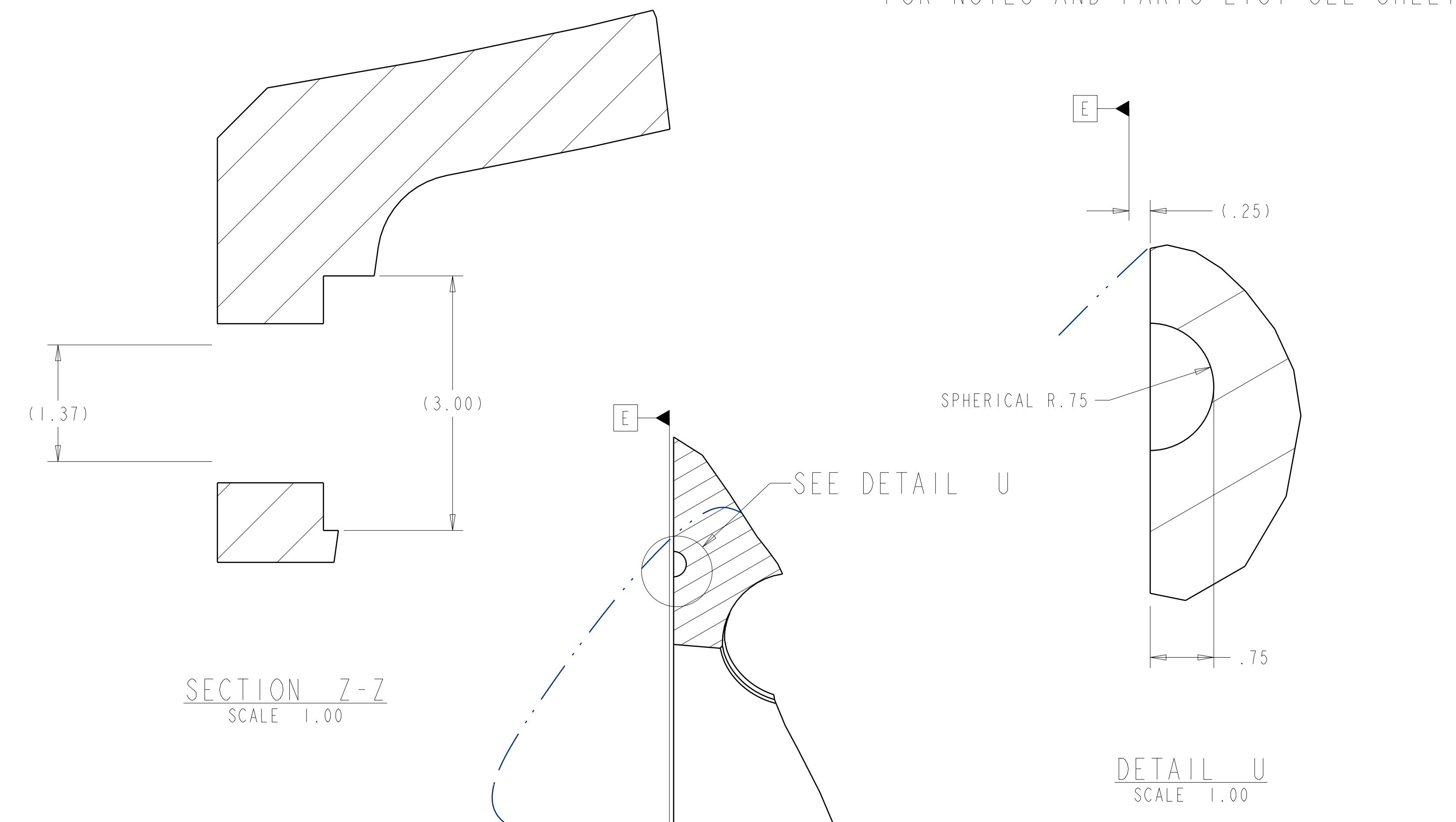

SECTION 7-7
SCALE 1.00

DETAIL U
SCALE 1.00

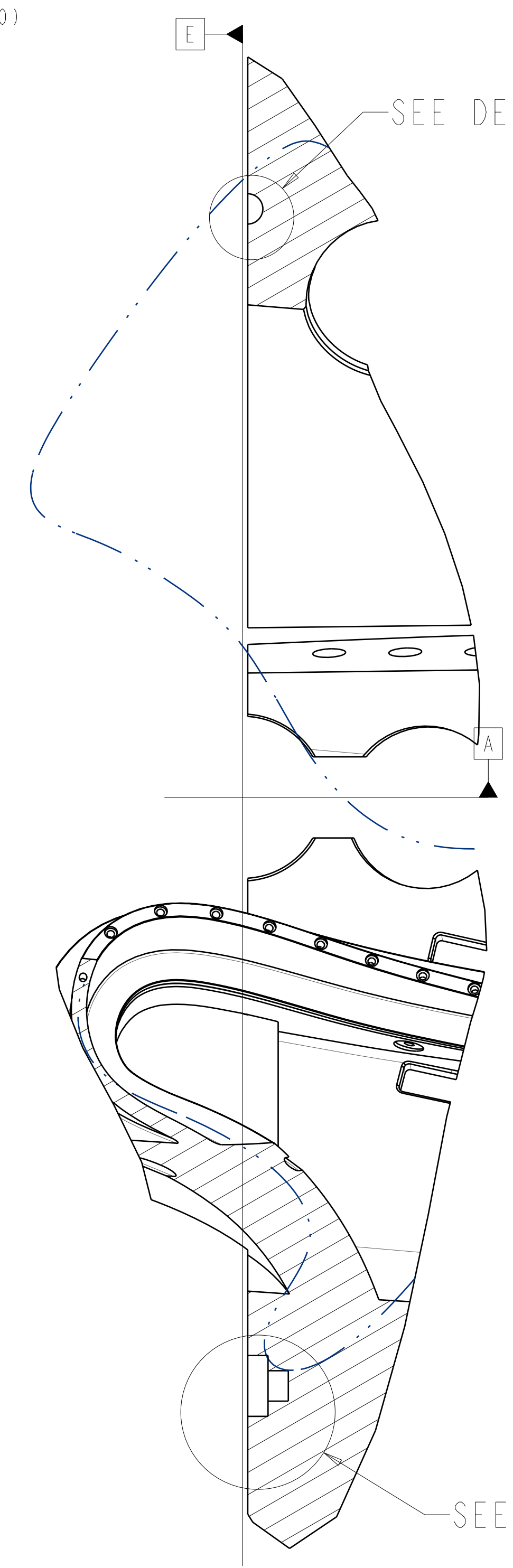

SECTION M-M

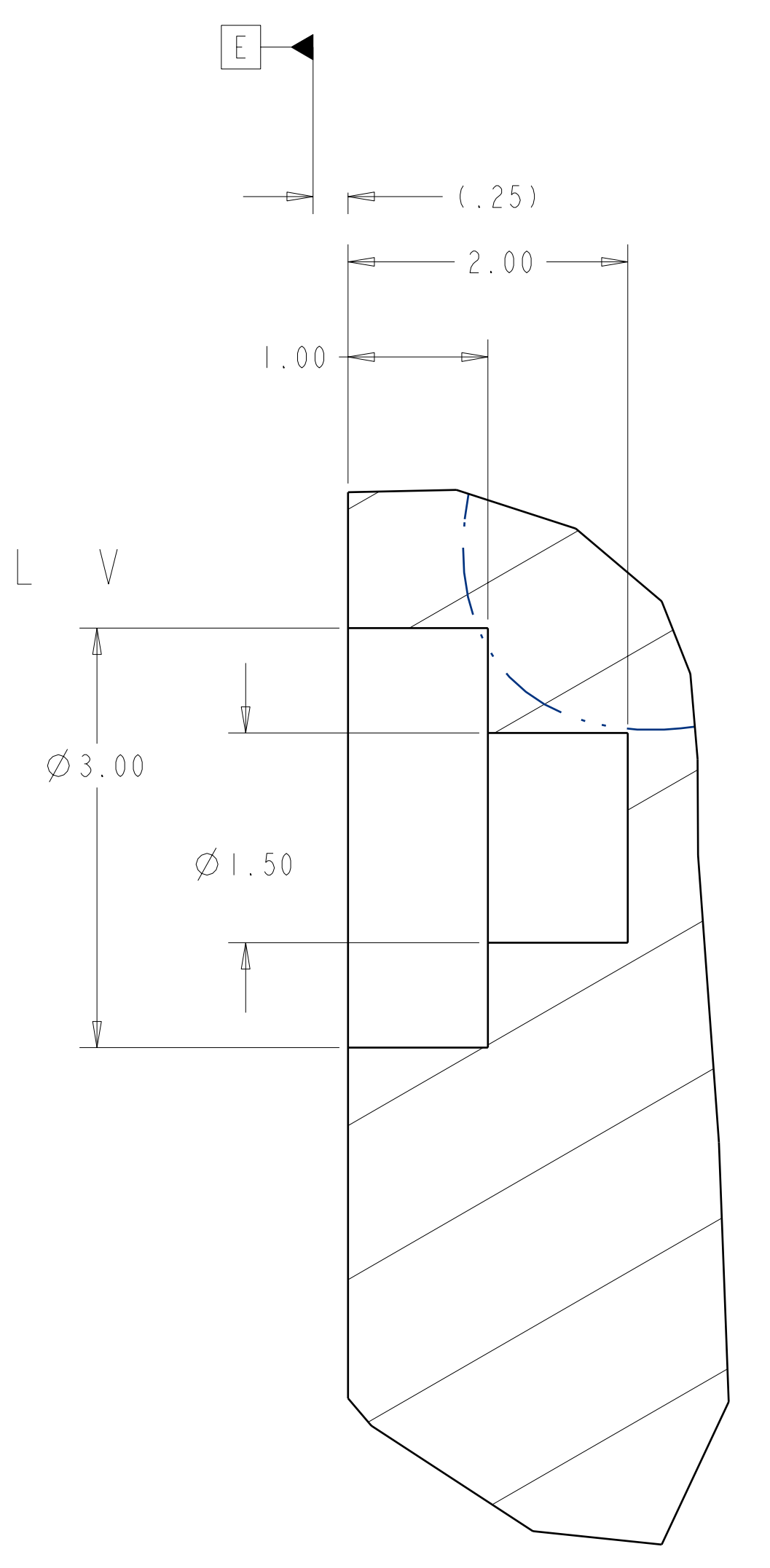

DETAIL V
SCALE 1.00

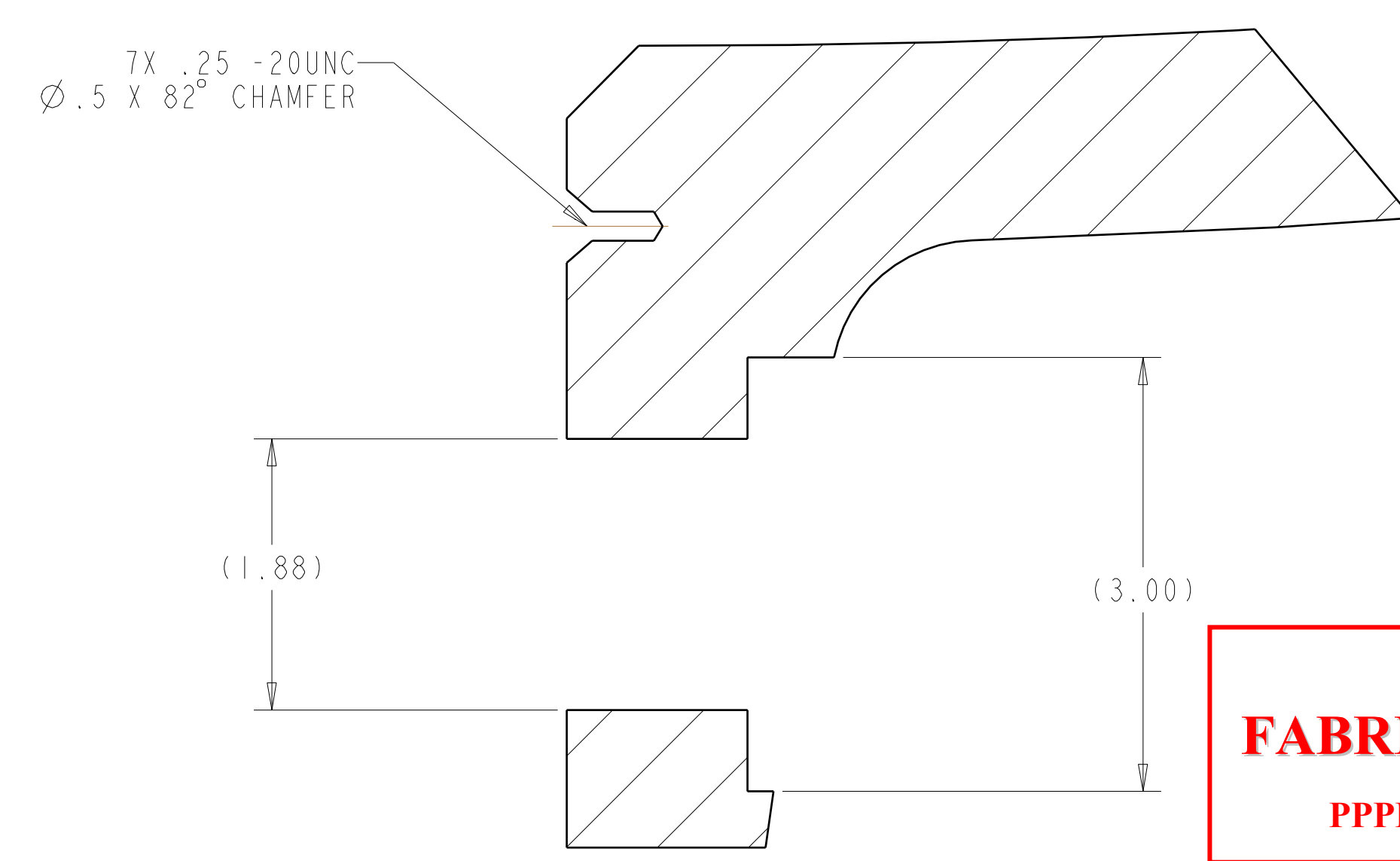

SECTION W-W
SCALE 1.00

RELEASED FOR FABRICATION / INSTALLATION
PPPL Drafting:

Oak Ridge National Laboratory managed for the DEPARTMENT OF ENERGY under U.S. GOVERNMENT contract DE-AC05-00OR22725 UT-BATTELLE, LLC. Oak Ridge, Tennessee PROJECT NAME:							
NATIONAL COMPACT STELLARATOR EXPERIMENT							
PRODUCTION WINDING FORM TYPE-C							
VERSION NO.	PLANT	BLDG	FL	SHT OF	TYPE	CLASS	
10	X-10	5700	3	5	11	S	U
RELEASE LEVEL		SEI41-116				REV 4	
Fabrication							

SEI41-116

FOR NOTES AND PARTS LIST SEE SHEET 1

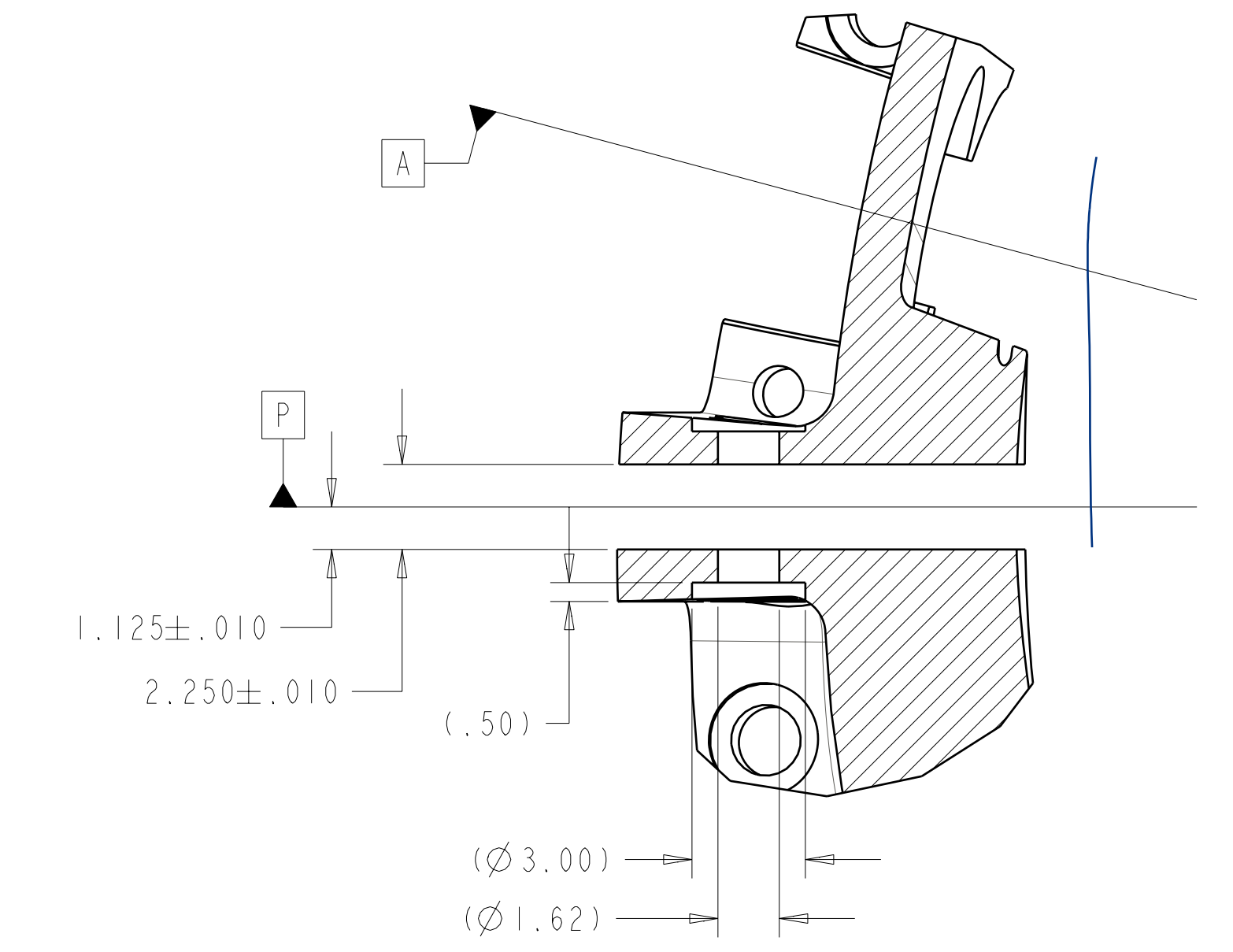
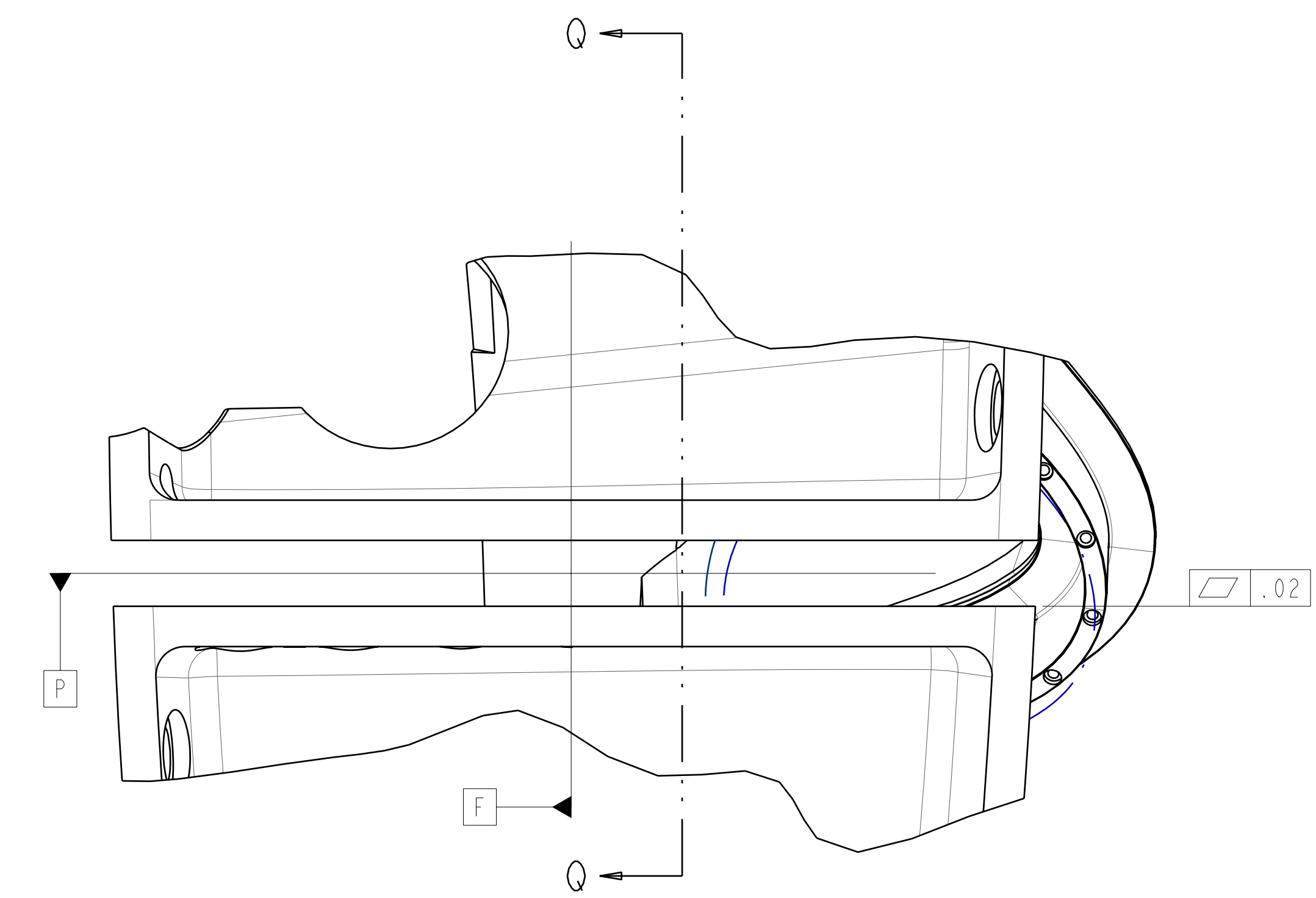
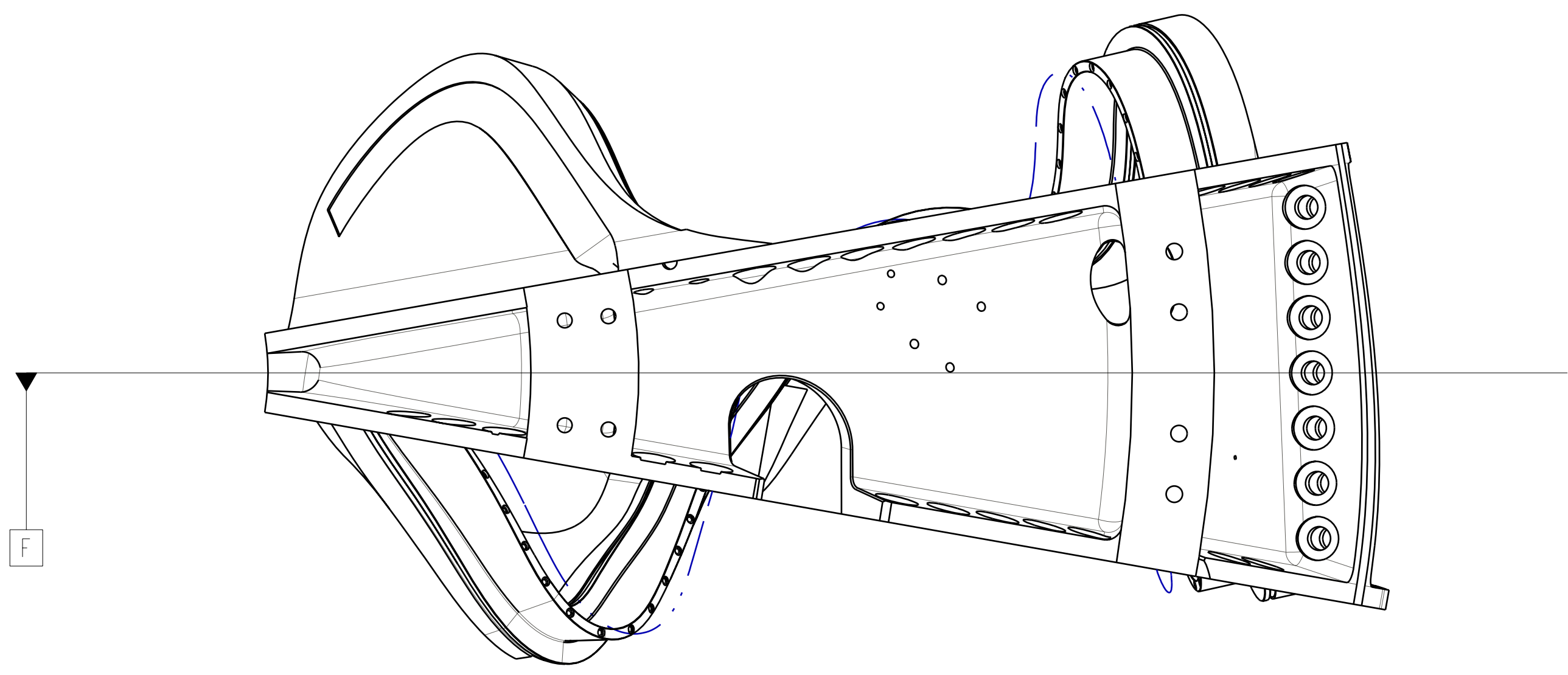

SECTION Q-Q

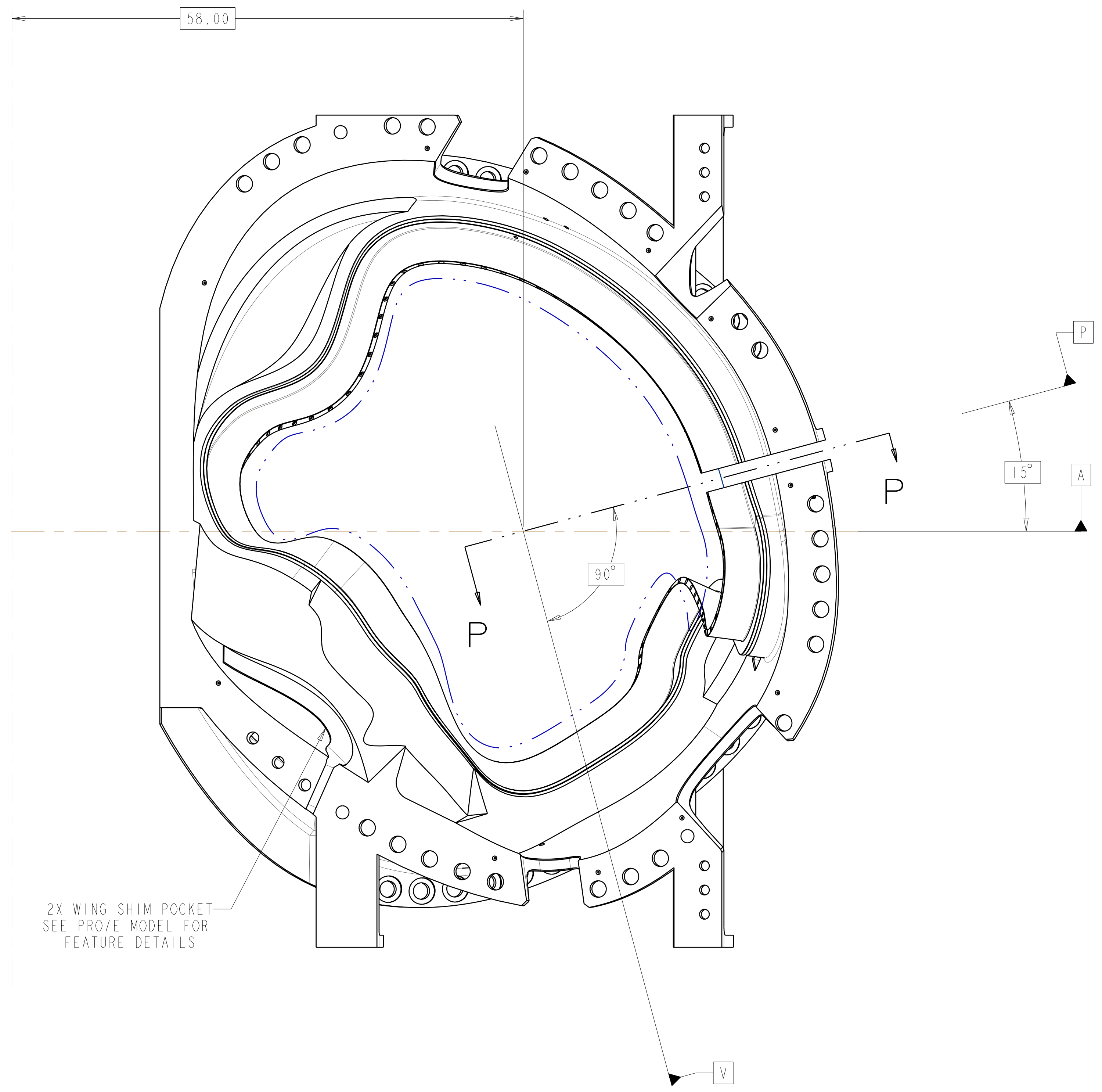

POLOIDAL BREAK DETAIL

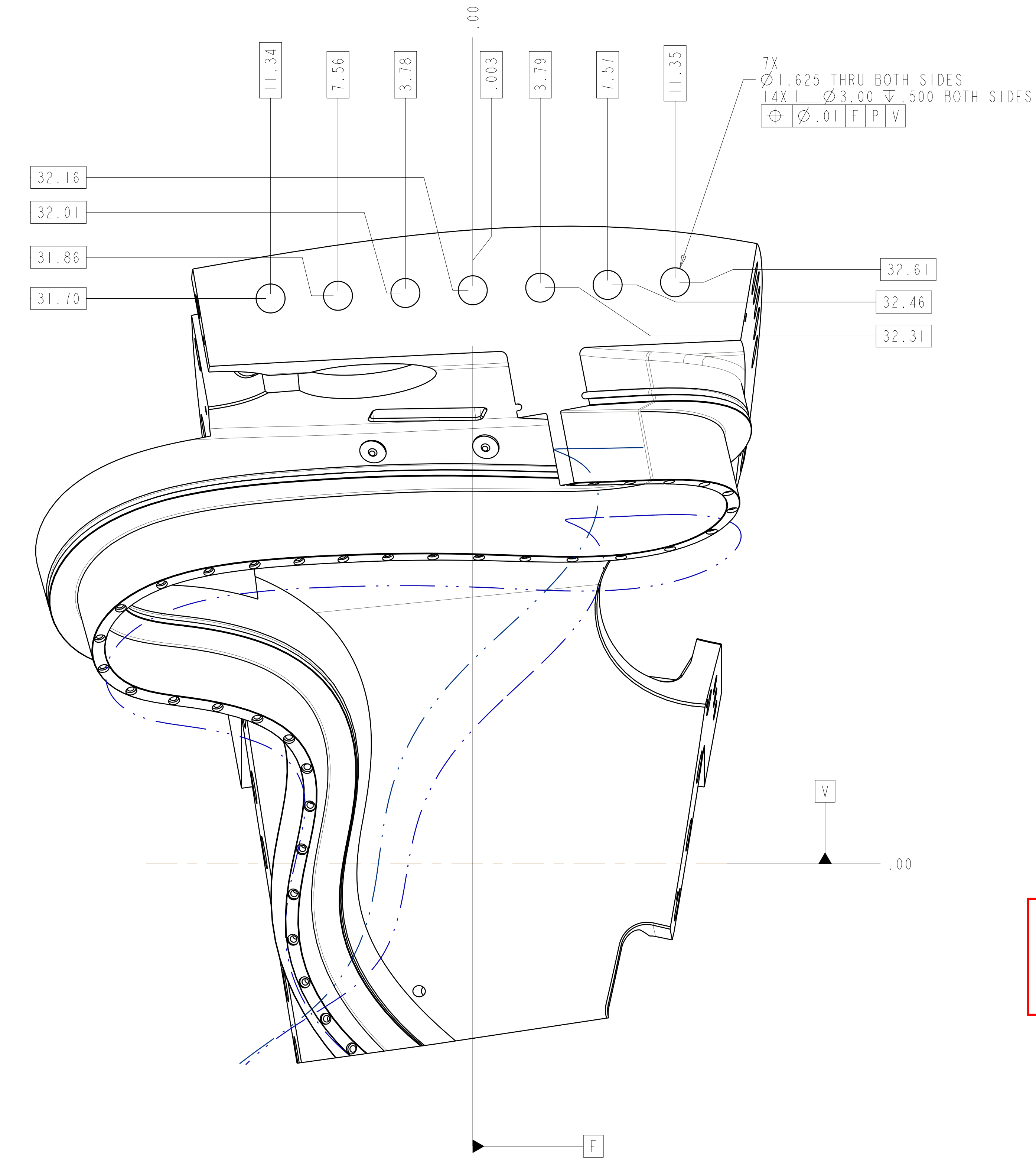

SECTION P-P
SCALE 0.25

**RELEASED FOR
FABRICATION / INSTALLATION**
PPPL Drafting:

UT-BATTELLE		Oak Ridge National Laboratory managed for the DEPARTMENT OF ENERGY under U.S. GOVERNMENT contract DE-AC05-00OR22725 UT-BATTELLE, LLC, Oak Ridge, Tennessee	
PROJECT NAME NATIONAL COMPACT STELLARATOR EXPERIMENT			
CLASSIFICATION PRODUCTION WINDING FORM TYPE-C			
VERSION NO. 10	PLANT X-10	BLDG 5700	FL SHT OF TYPE CLASS 3 6 11 S U
RELEASE LEVEL Fabrication		SEI41-116 REV 4	

H
G
F
E
D
C
B
A

FOR NOTES AND PARTS LIST SEE SHEET 1

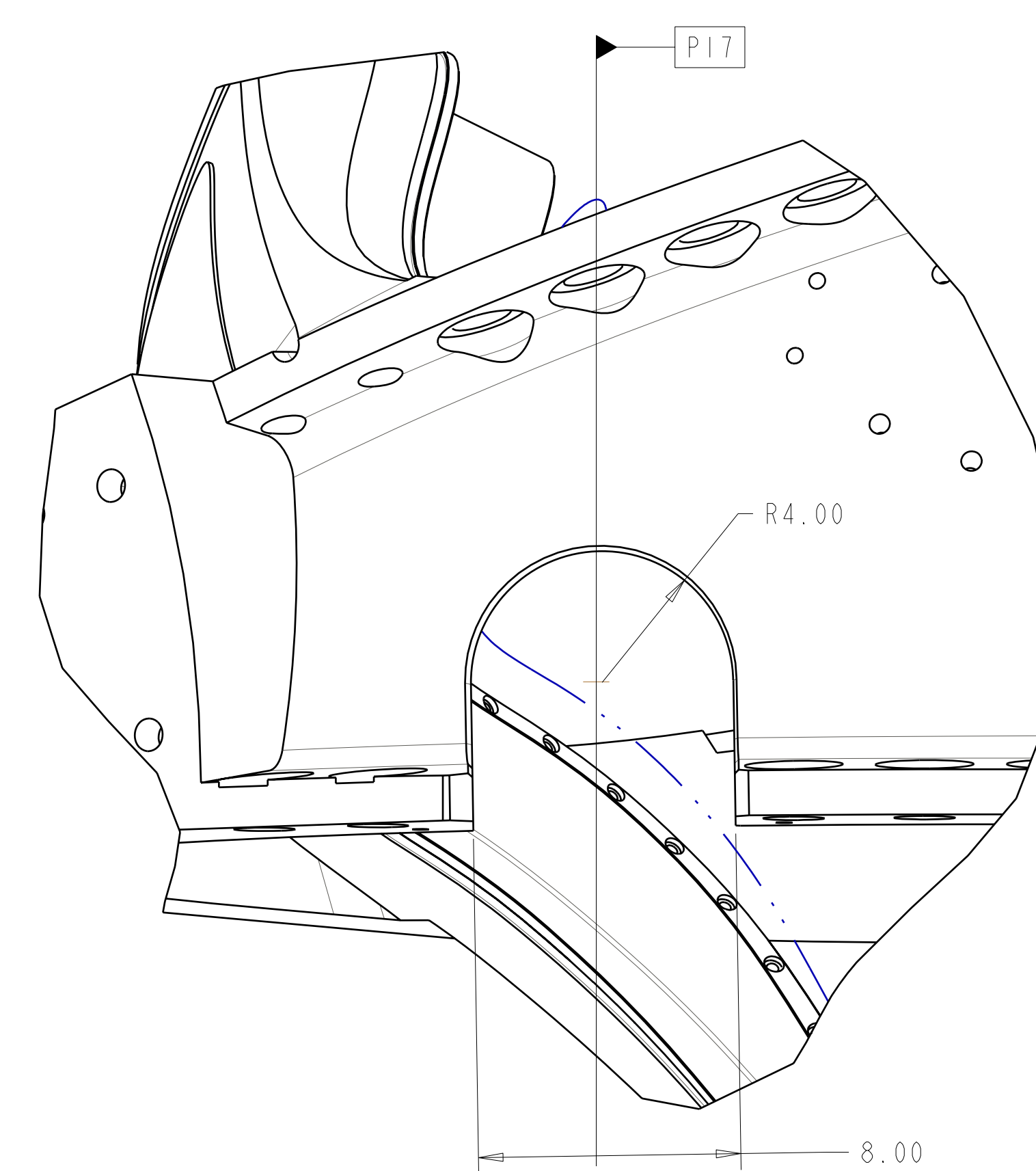
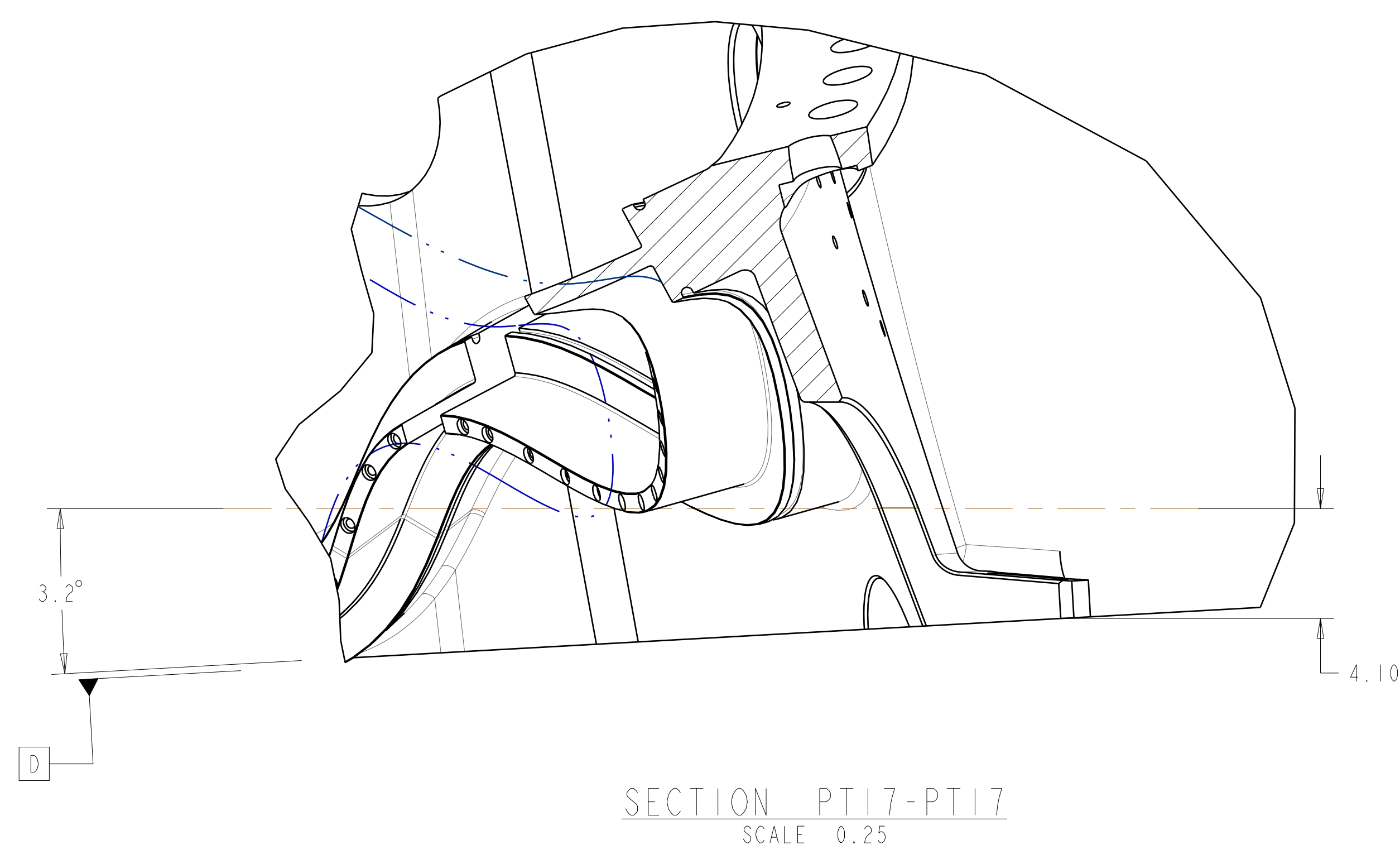
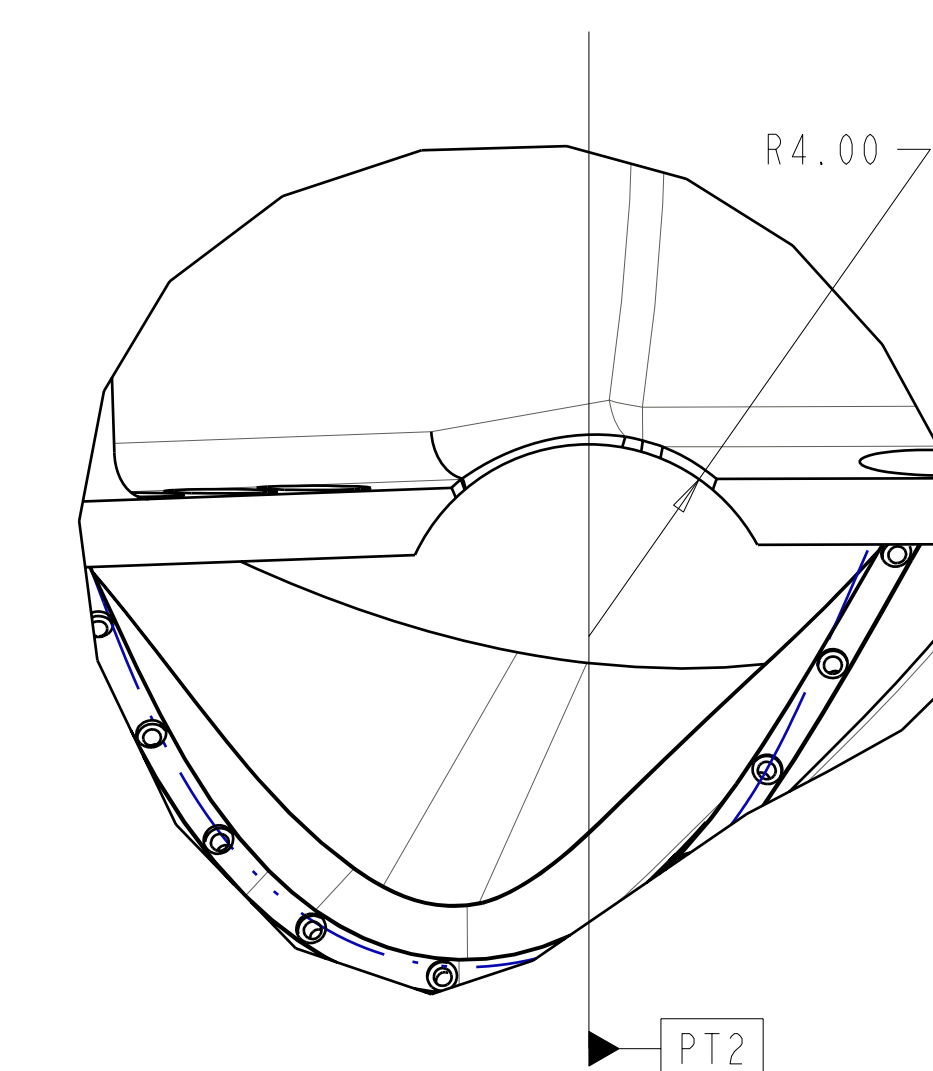
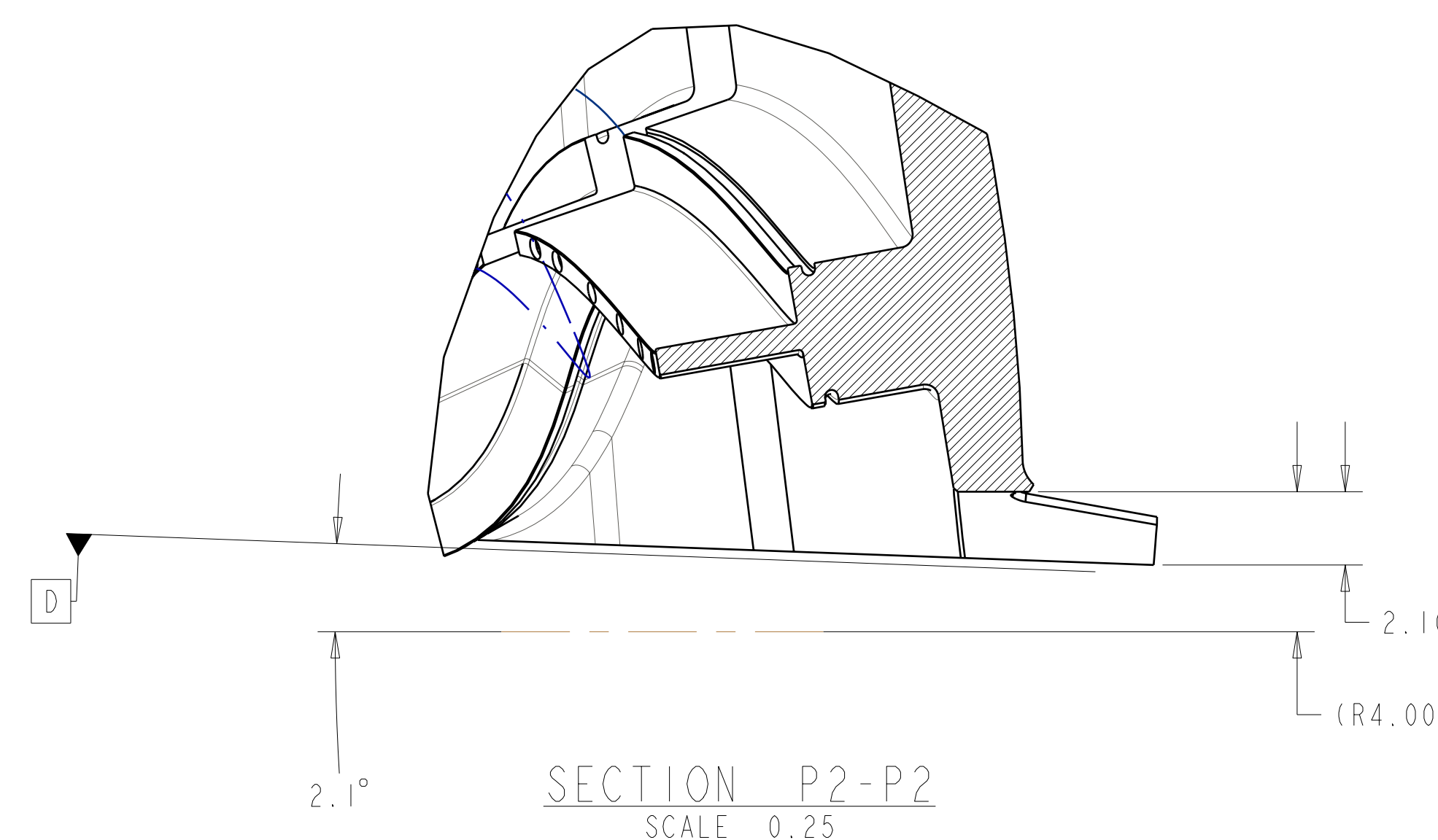
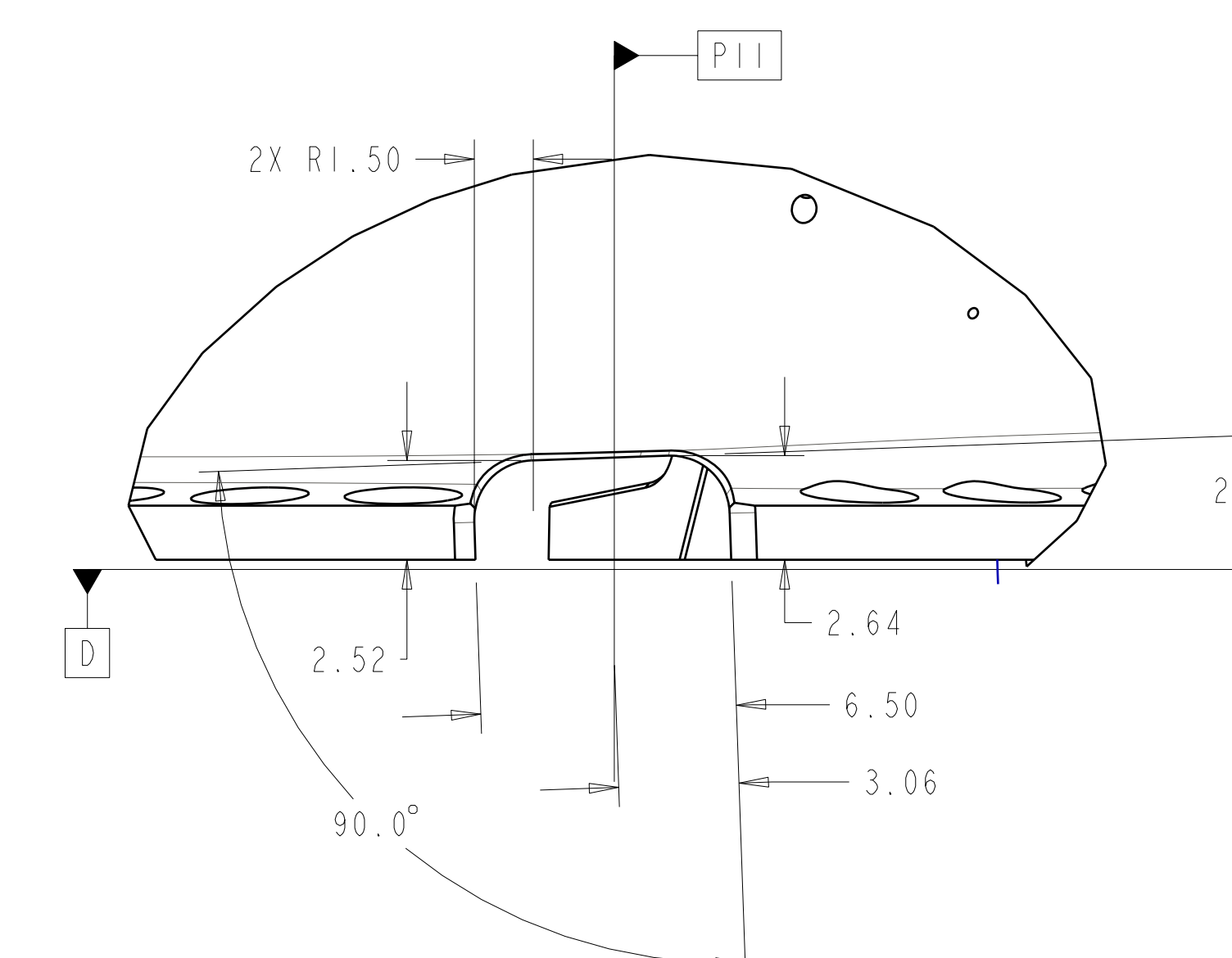
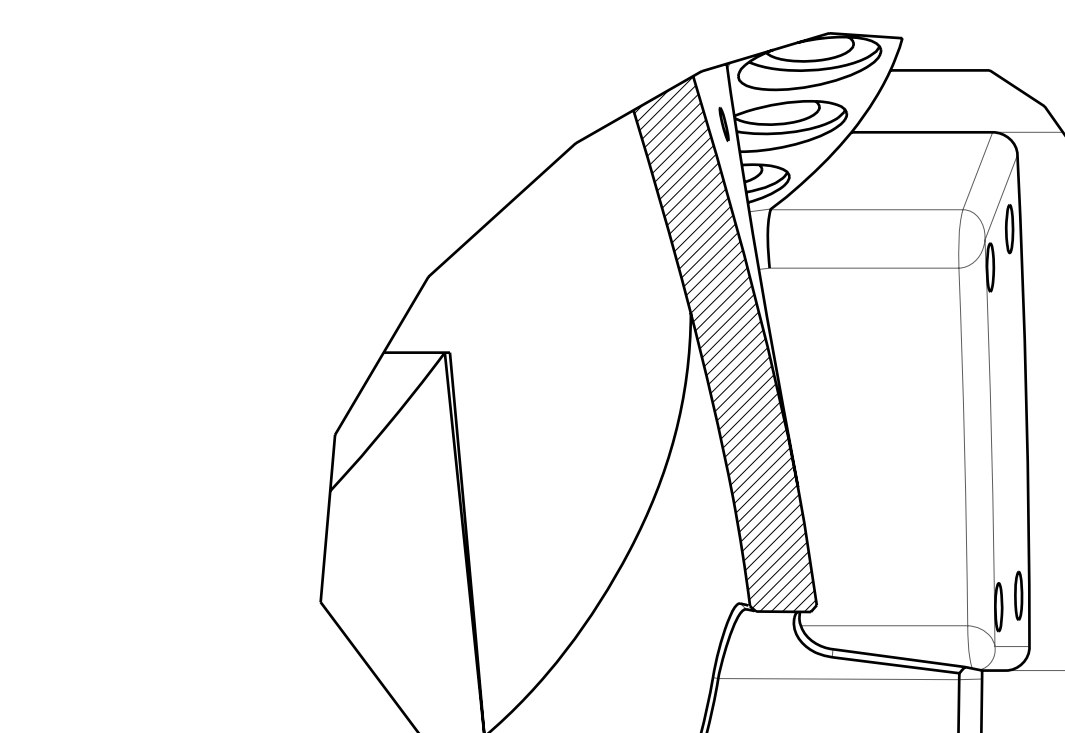
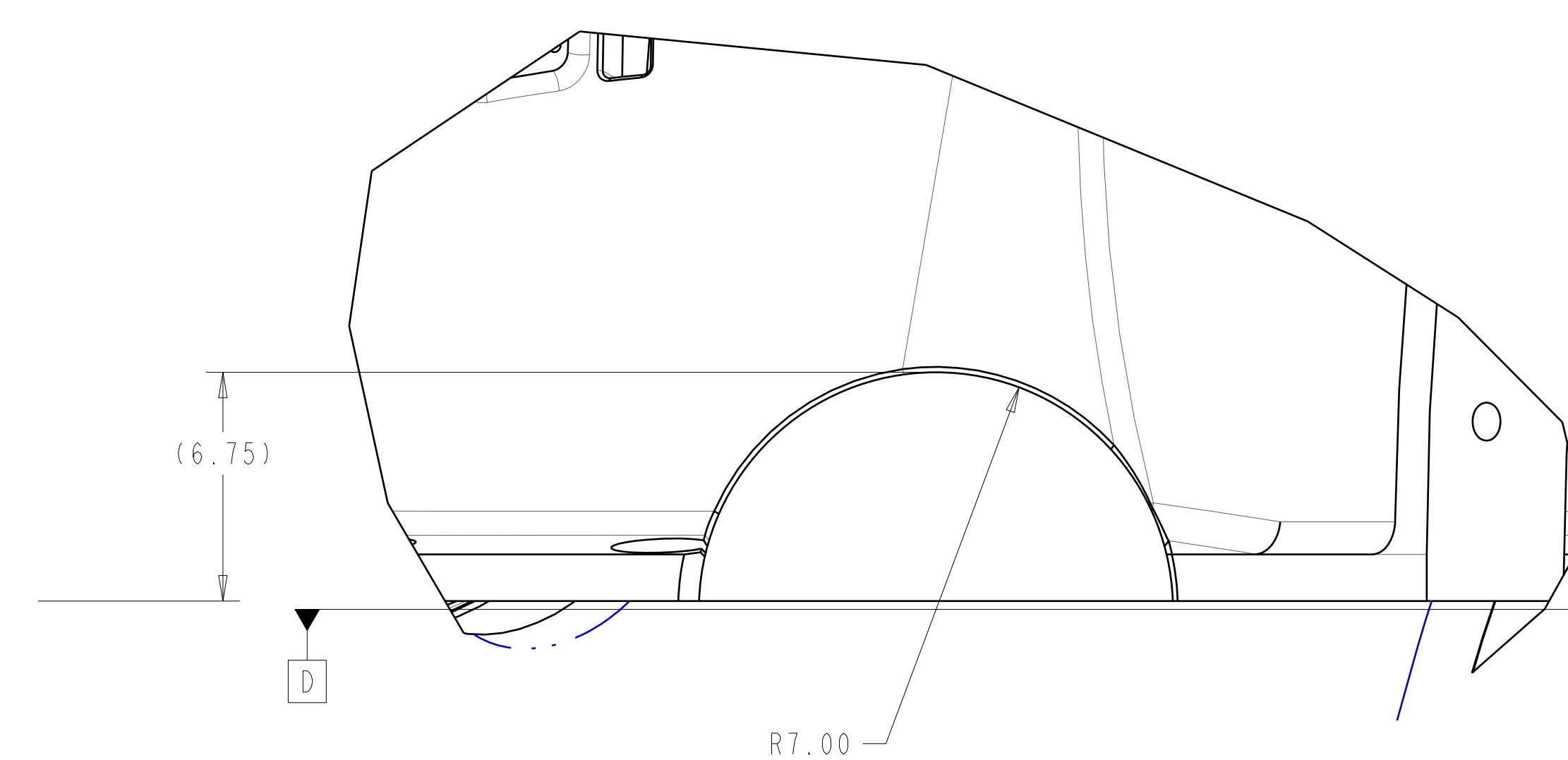
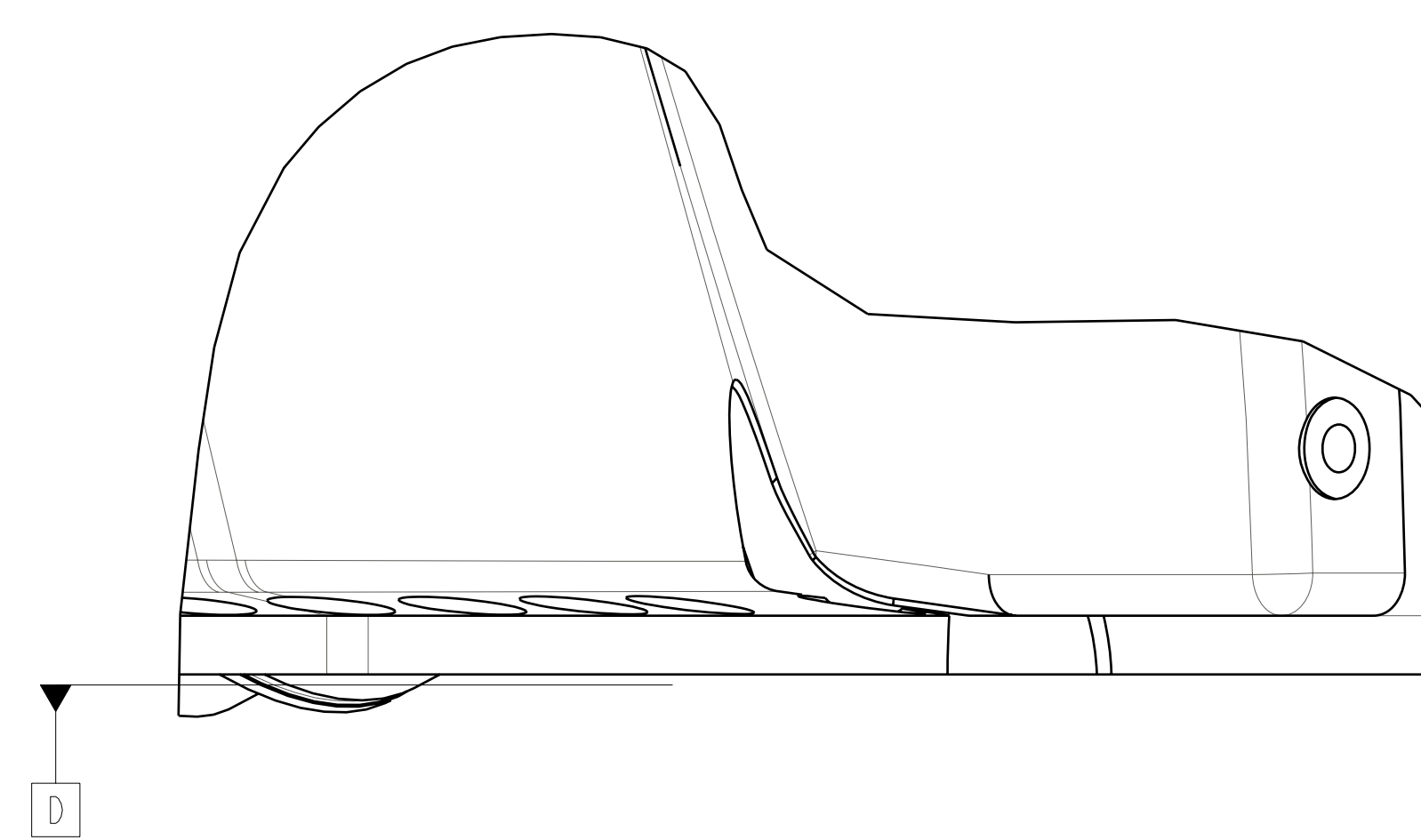
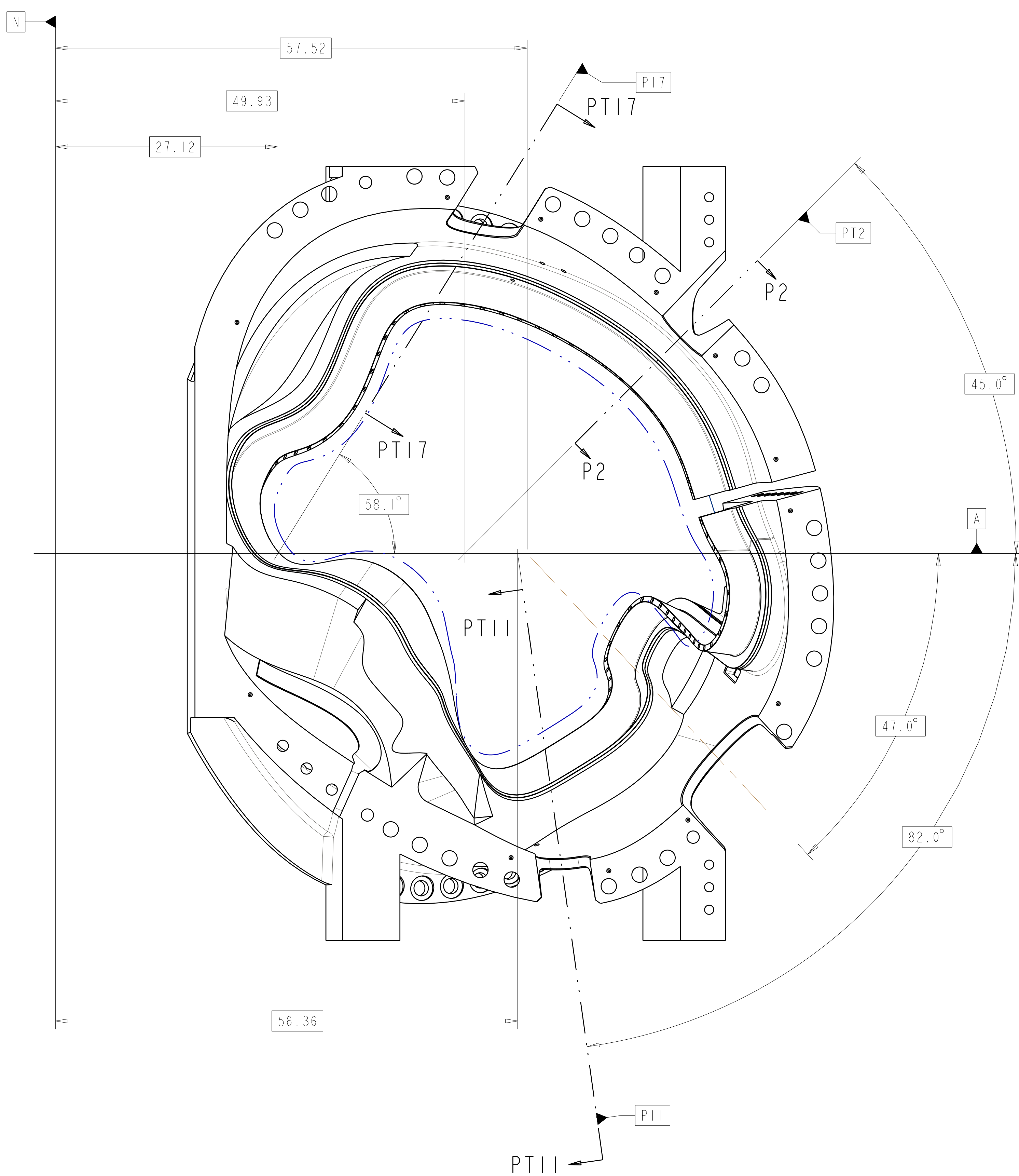

**RELEASED FOR
FABRICATION / INSTALLATION**

PPPL Drafting:

Oak Ridge National Laboratory managed for the DEPARTMENT OF ENERGY under U.S. GOVERNMENT contract DE-AC05-00OR22725 UT-BATTELLE, LLC, Oak Ridge, Tennessee							
UT-BATTELLE							
NATIONAL COMPACT STELLARATOR EXPERIMENT							
PRODUCTION WINDING FORM TYPE-C							
VERSION NO.	PLANT	BLDG	FL	SHT OF	TYPE	CLASS	
10	X-10	5700	3	7	III	S	U
RELEASE LEVEL	SEI41-116						REV
Fabrication							4

FOR NOTES AND PARTS LIST SEE SHEET 1

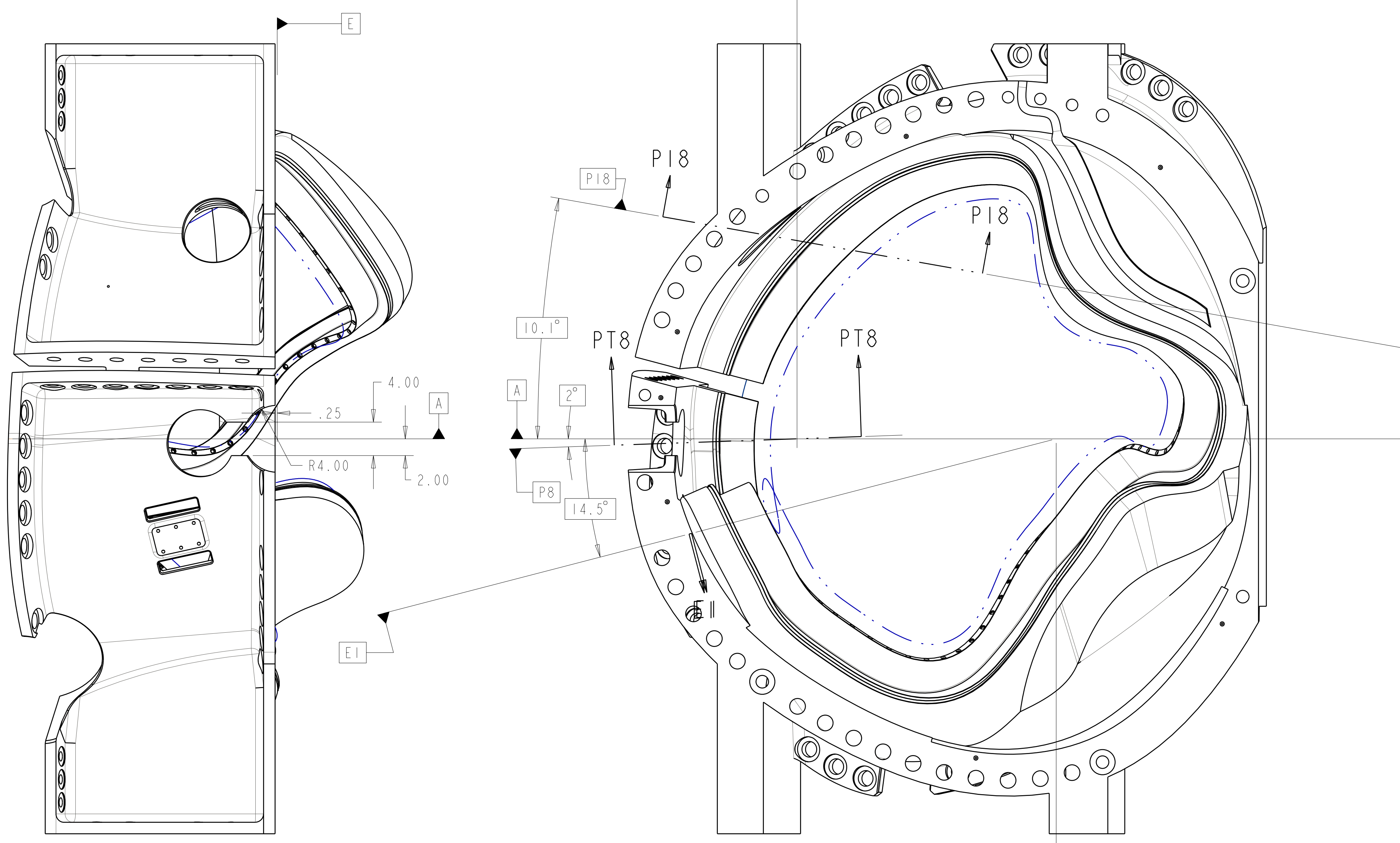

VIEW AT DATUM E
SCALE 0.13

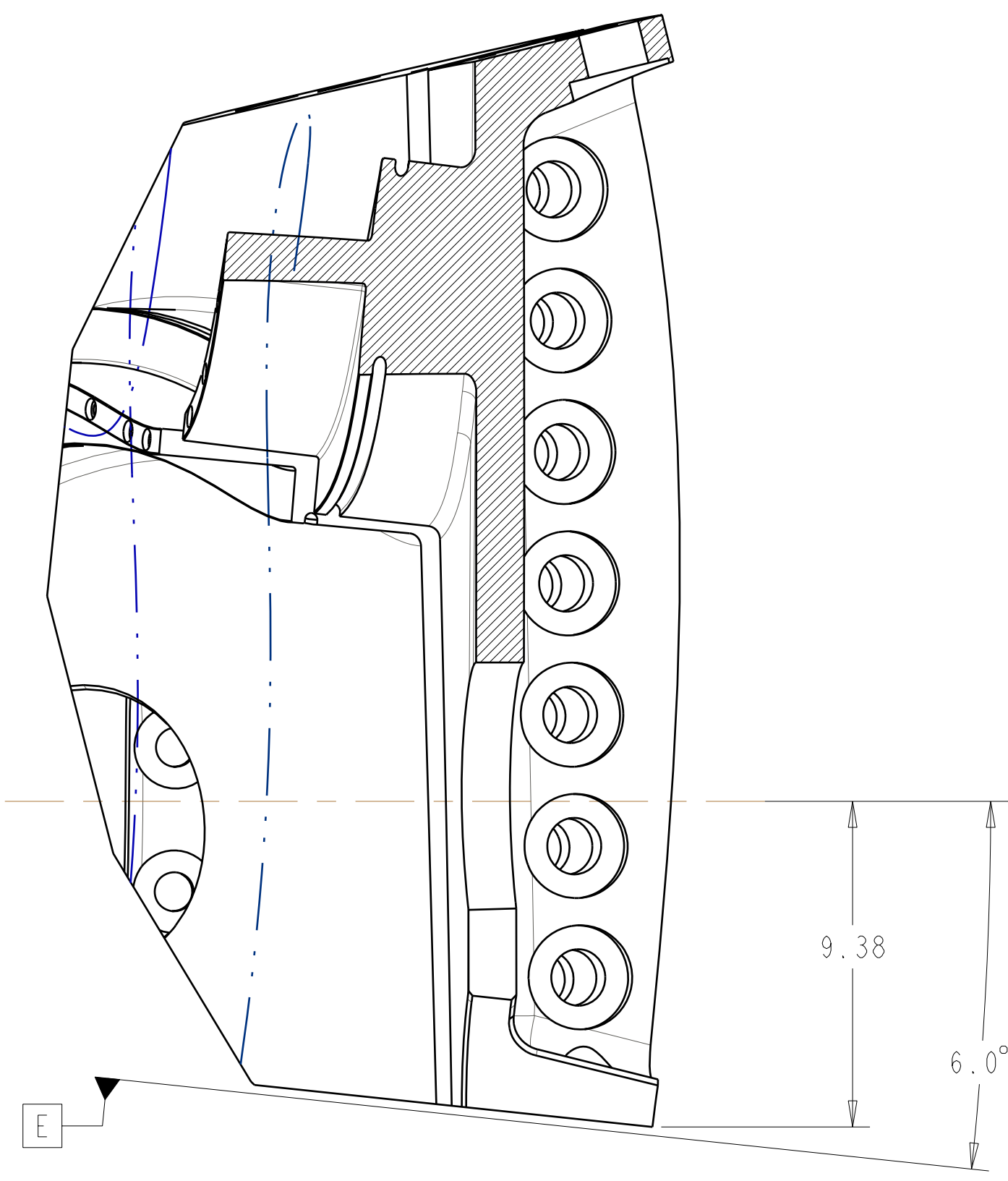

SECTION PT8-PT8
SCALE 0.25

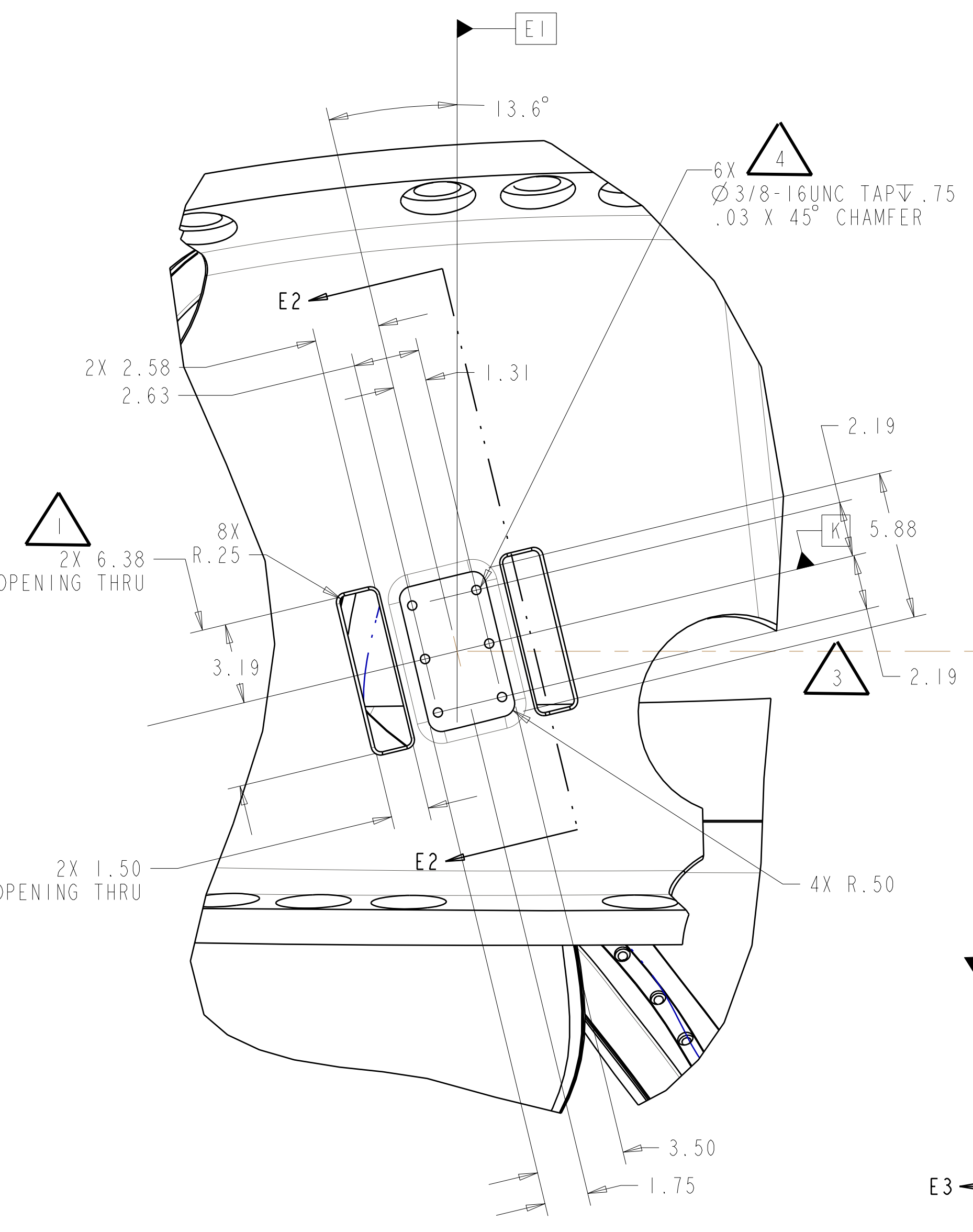
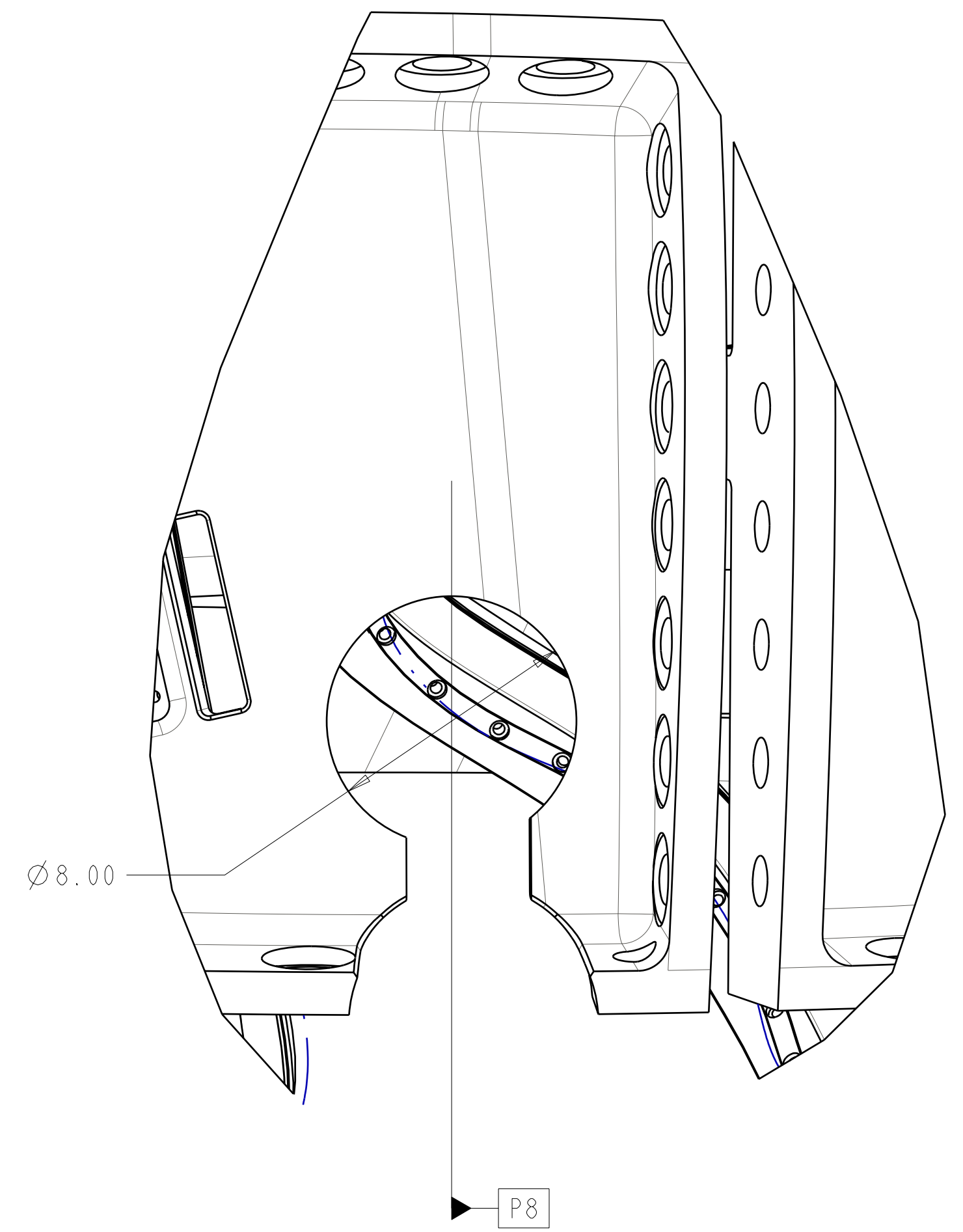

LEAD BLOCK DETAIL

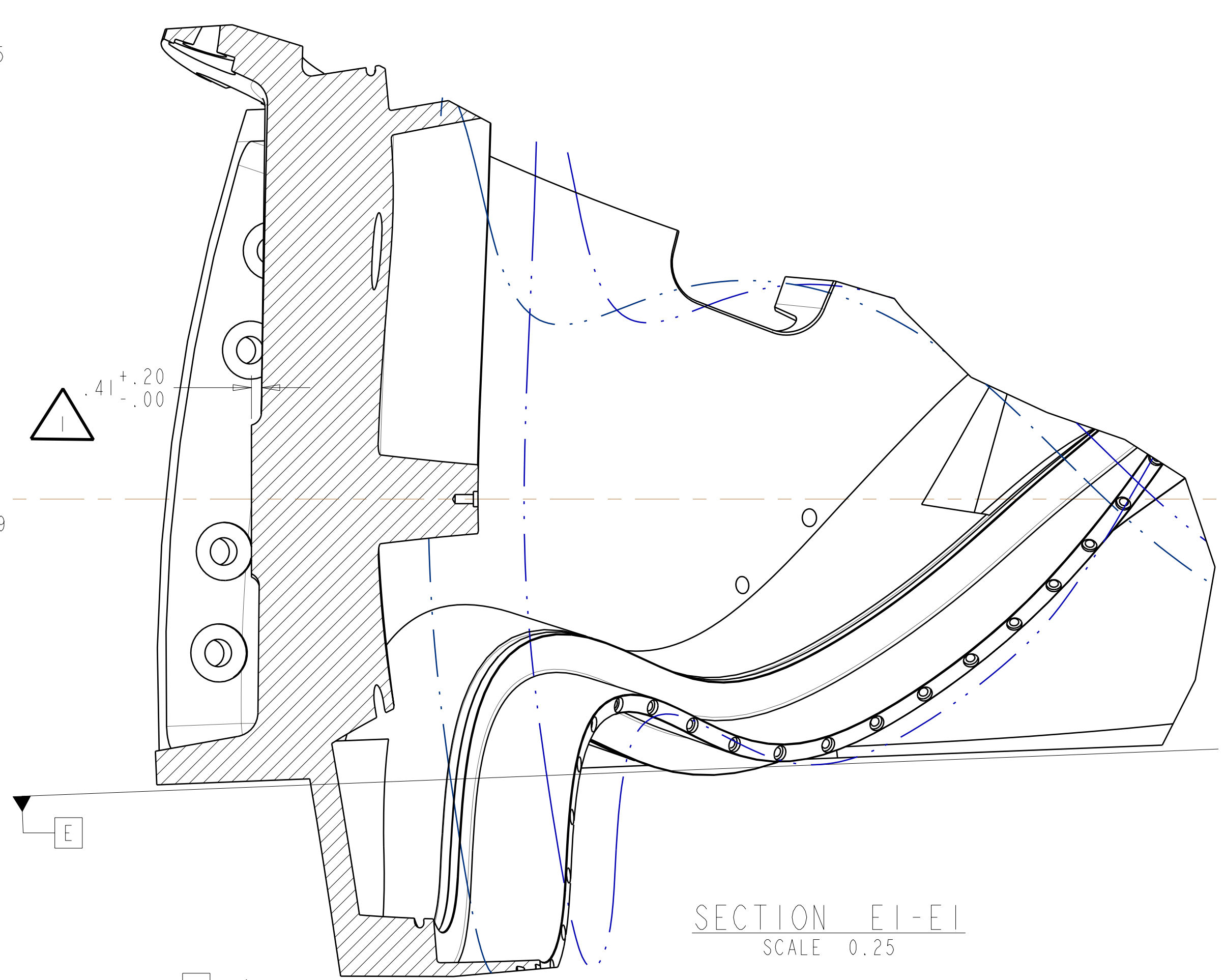

SECTION E1-E1
SCALE 0.25

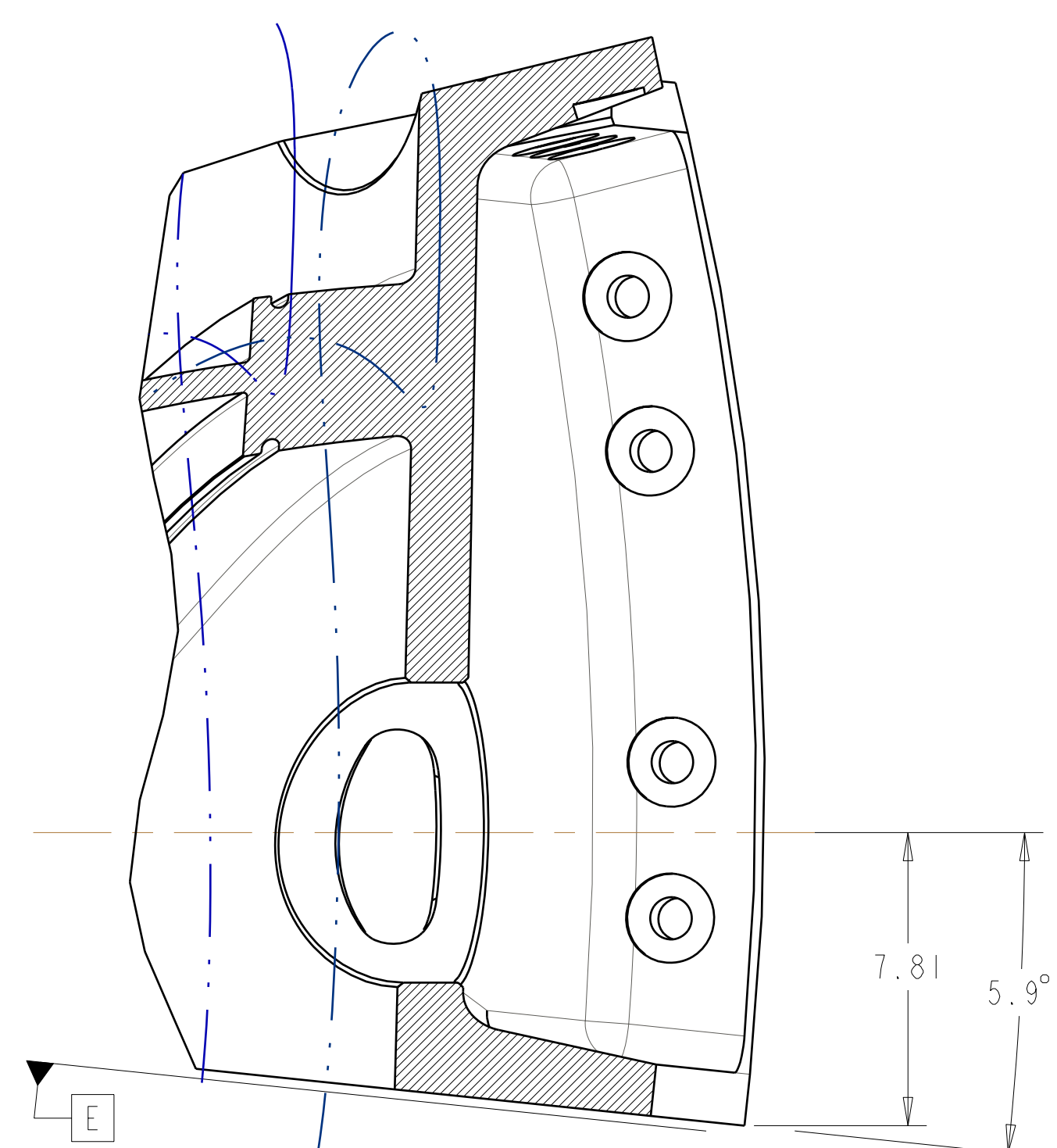

SECTION P18-P18
SCALE 0.25

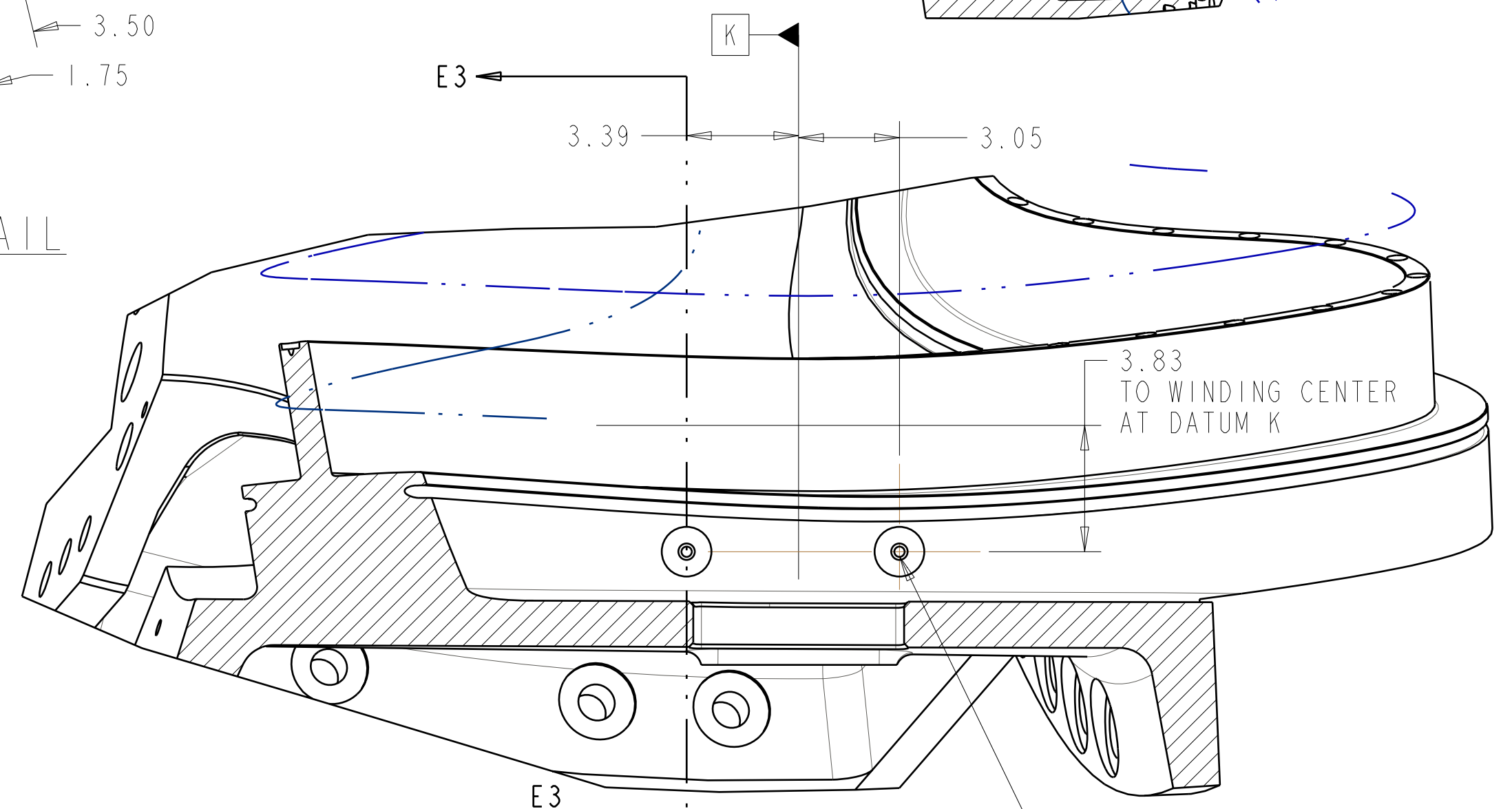

SECTION E2-E2
SCALE 0.250

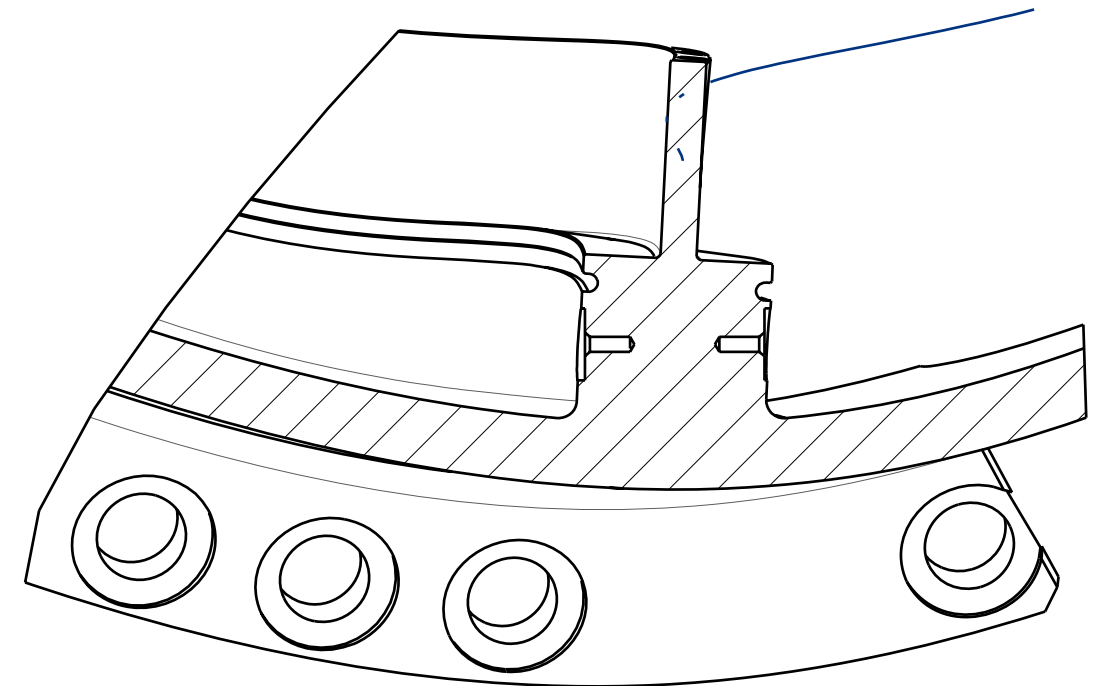

SECTION E3-E3

RELEASED FOR FABRICATION / INSTALLATION
PPPL Drafting:

Oak Ridge National Laboratory managed for the DEPARTMENT OF ENERGY under U.S. GOVERNMENT contract DE-AC05-00OR22725 UT-BATTELLE, LLC. Oak Ridge, Tennessee PROJECT NAME:							
UT-BATTELLE NATIONAL COMPACT STELLARATOR EXPERIMENT							
PRODUCTION WINDING FORM TYPE-C							
VERSION NO.	PLANT	BLDG	FL	SHT OF	TYPE	CLASS	
10	X-10	5700	3	8	11	S	U
RELEASE LEVEL							REV
Fabrication	SE141-116						4

H
G
F
E
D
C
B
A
SE141-116

FOR NOTES AND PARTS LIST SEE SHEET 1

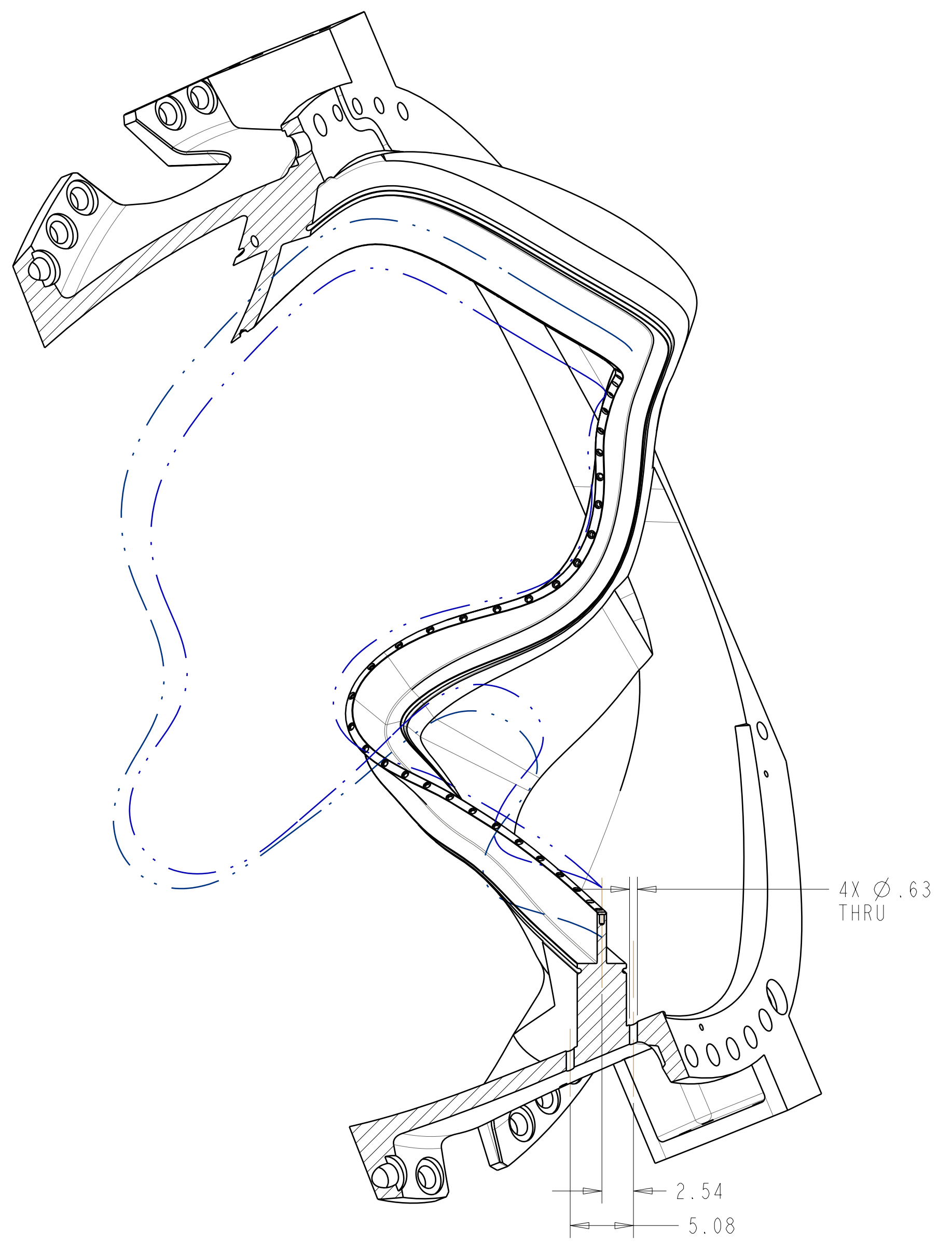

SECTION X-X
 USE PRO/E MODEL GEOMETRY TO DETERMINE SECTION ORIENTATION

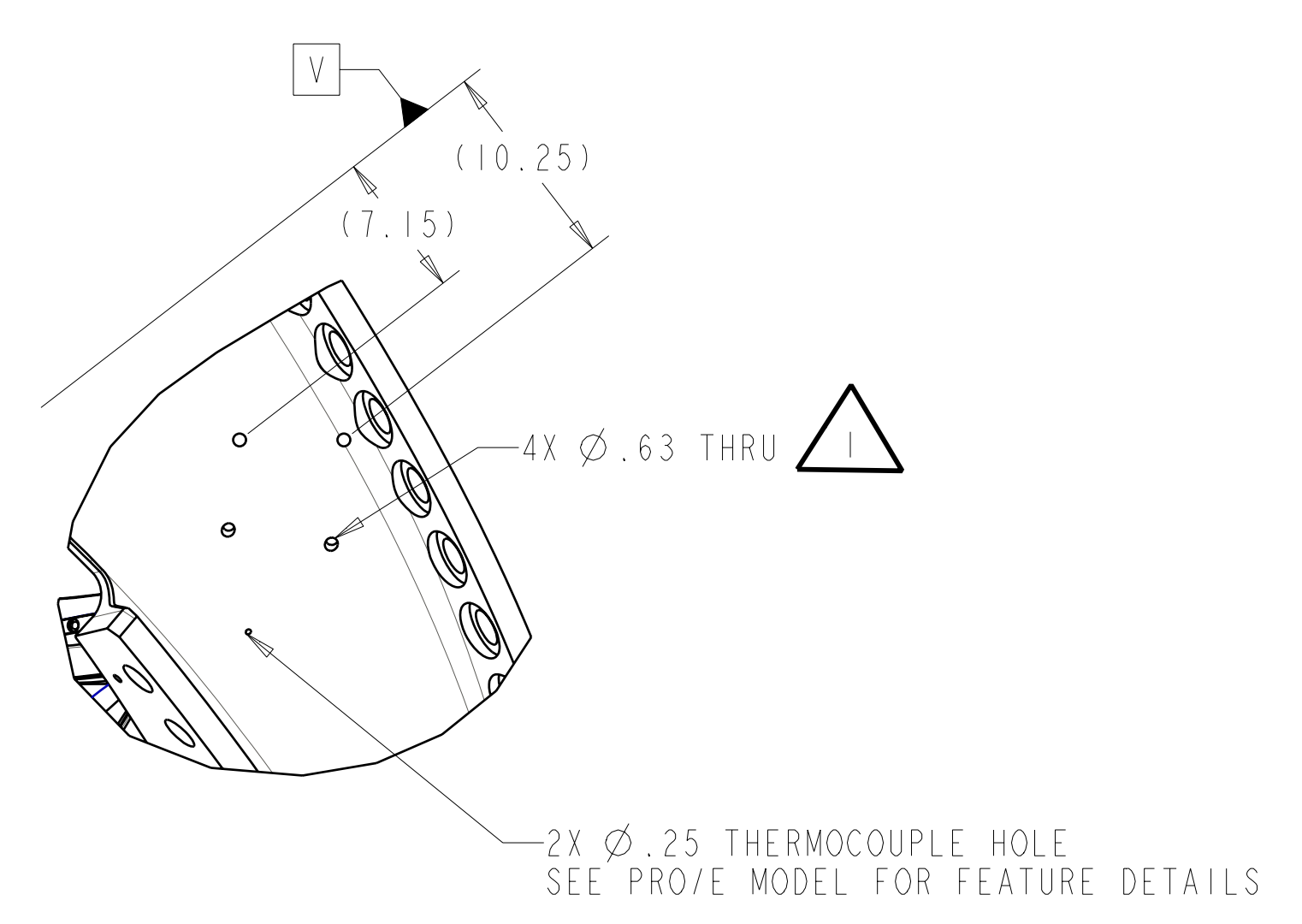
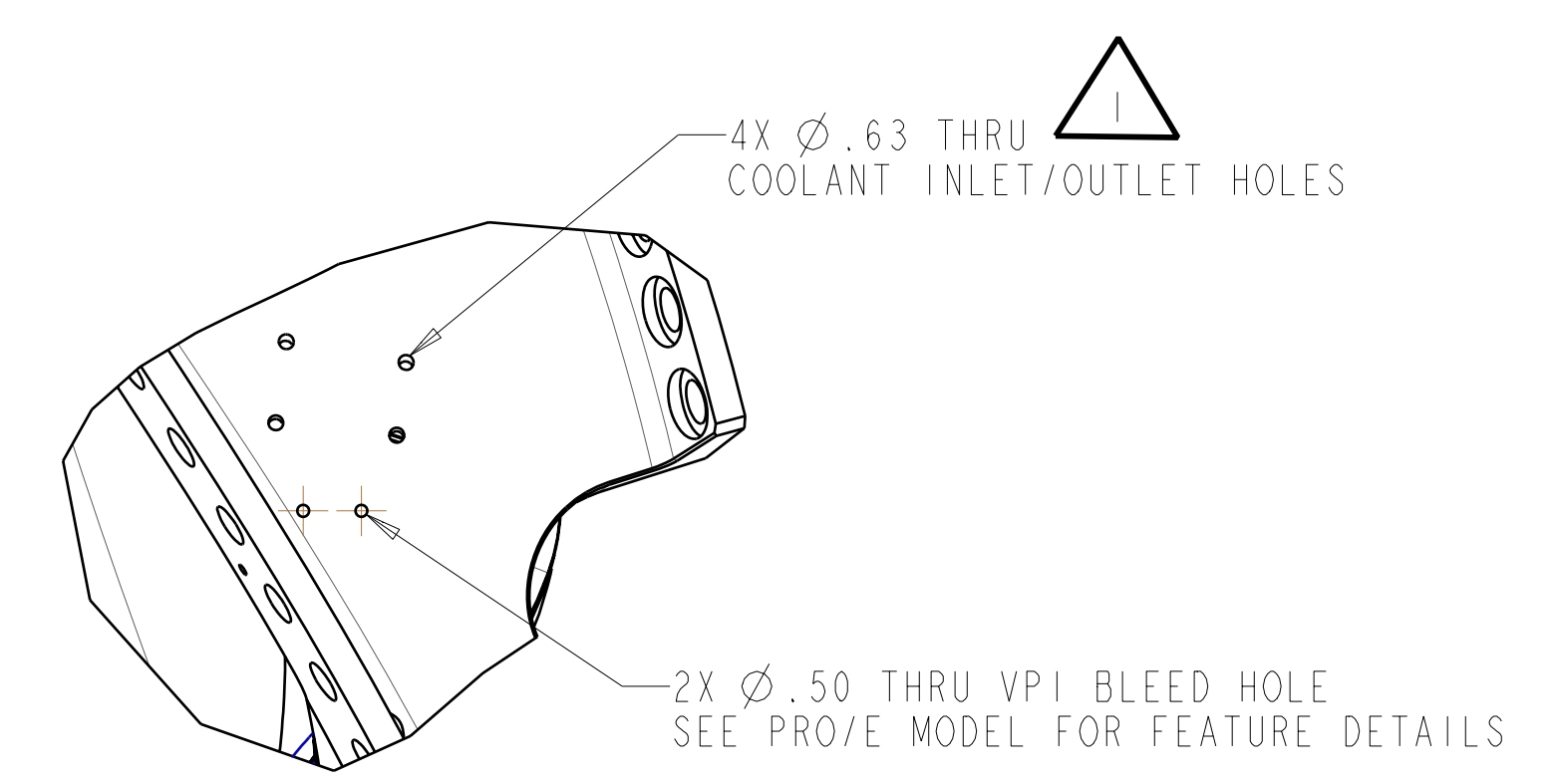
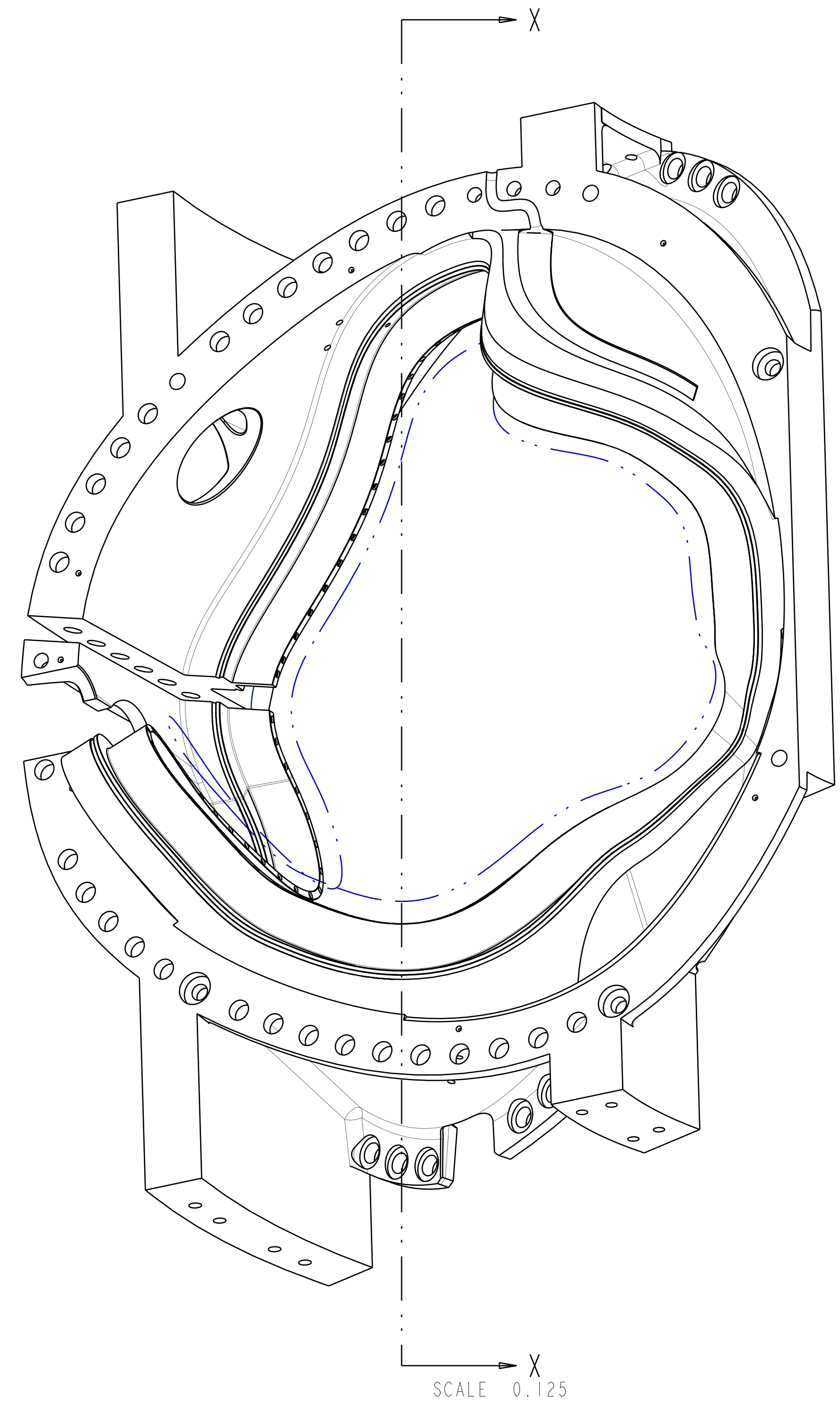

COOLING INLET / OUTLET HOLES
 TYPICAL 2 PLACES

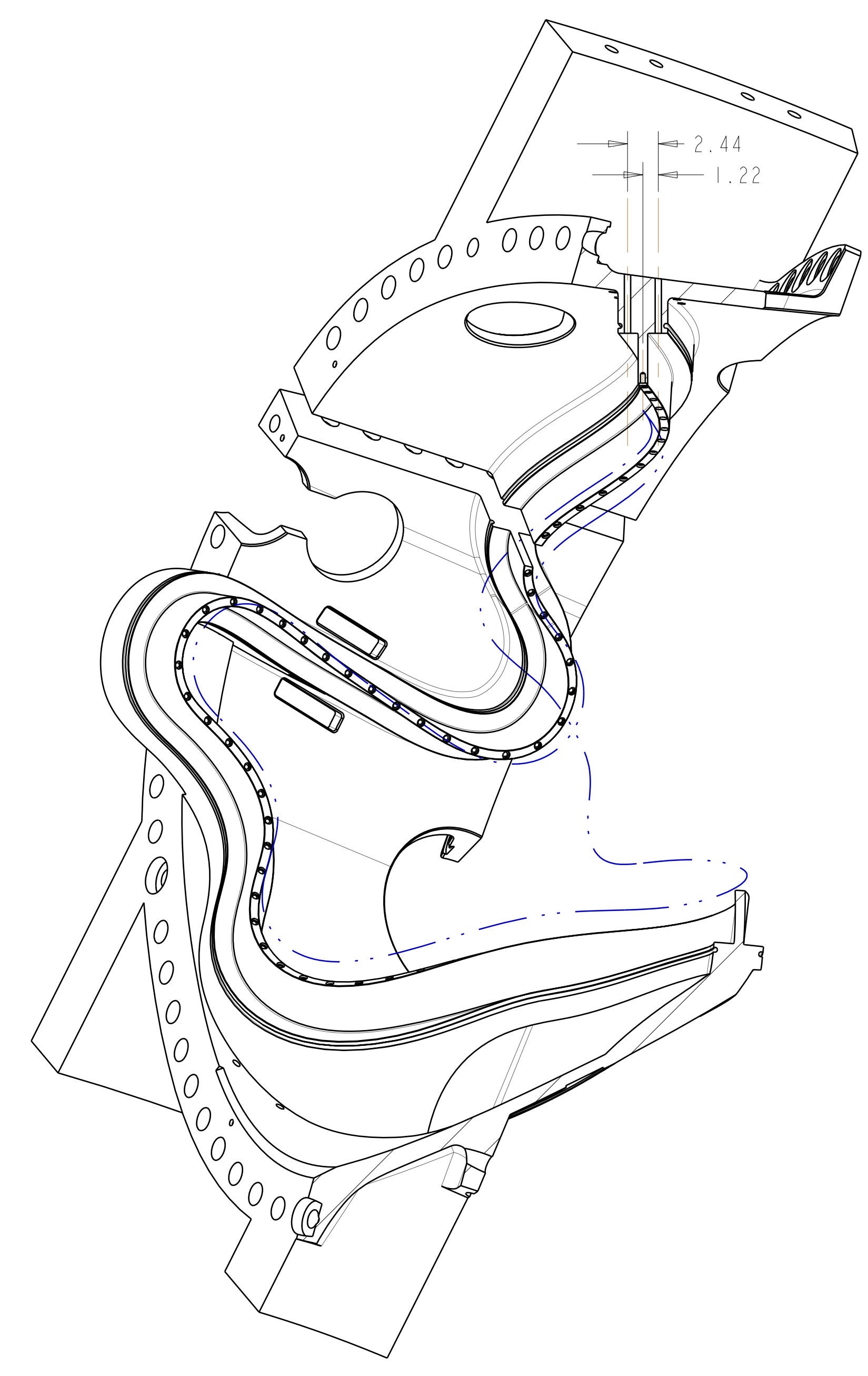

SECTION Y-Y
 SCALE 0.125

USE PRO/E MODEL GEOMETRY TO DETERMINE SECTION ORIENTATION

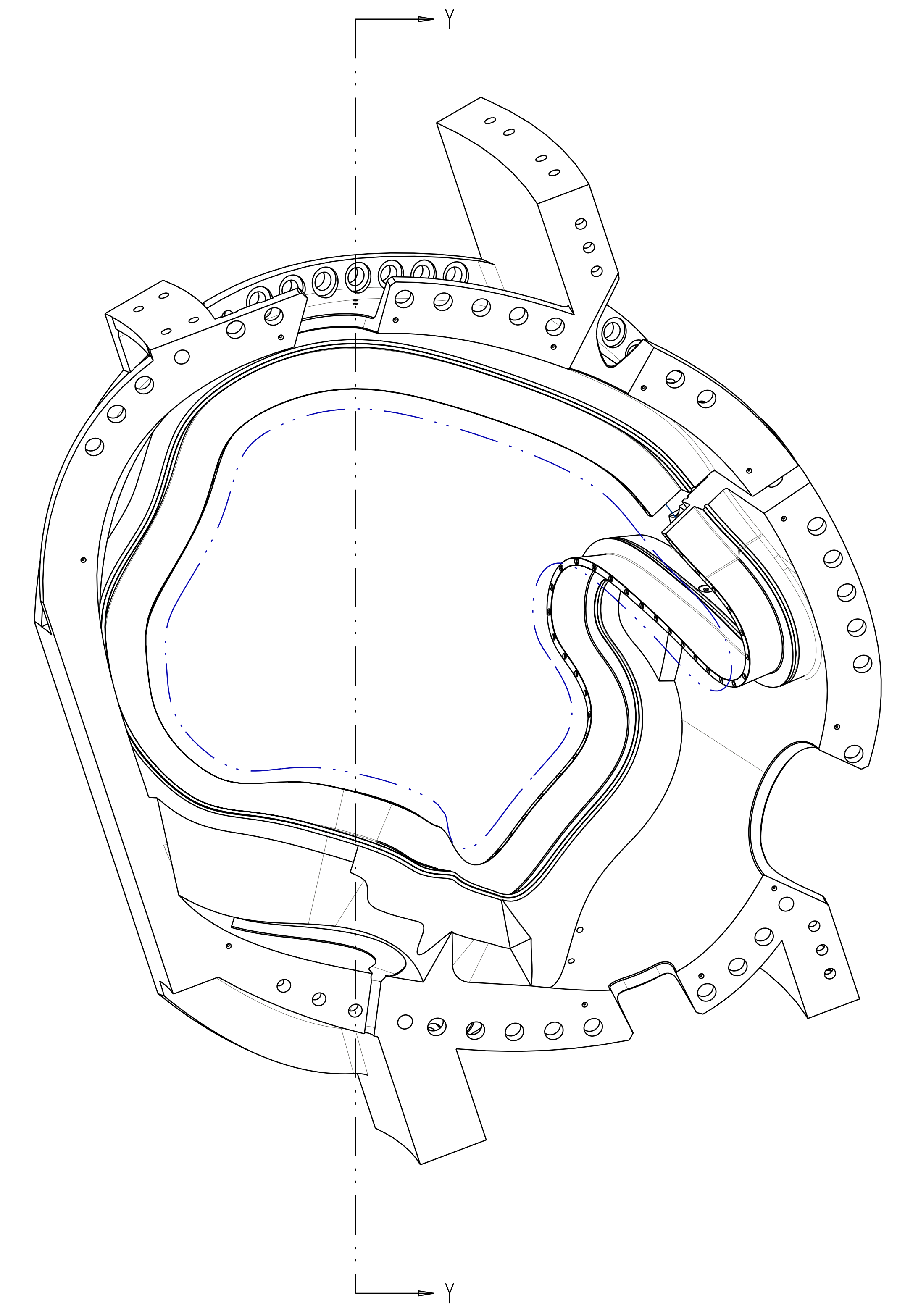

RELEASED FOR FABRICATION / INSTALLATION
 PPPL Drafting:

UT-BATTELLE		Oak Ridge National Laboratory managed for the DEPARTMENT OF ENERGY under U.S. GOVERNMENT contract DE-AC05-00OR22725 UT-BATTELLE, LLC, Oak Ridge, Tennessee					
NATIONAL COMPACT STELLARATOR EXPERIMENT							
PRODUCTION WINDING FORM TYPE-C							
VERSION NO.	PLANT	BLDG	FL	SHT OF	TYPE	CLASS	
10	X-10	5700	3	9	11	S	U
RELEASE LEVEL	SE141-116						REV
Fabrication							4

H
G
F
E
D
C
B
A

SE141-116

FOR NOTES AND PARTS LIST SEE SHEET 1

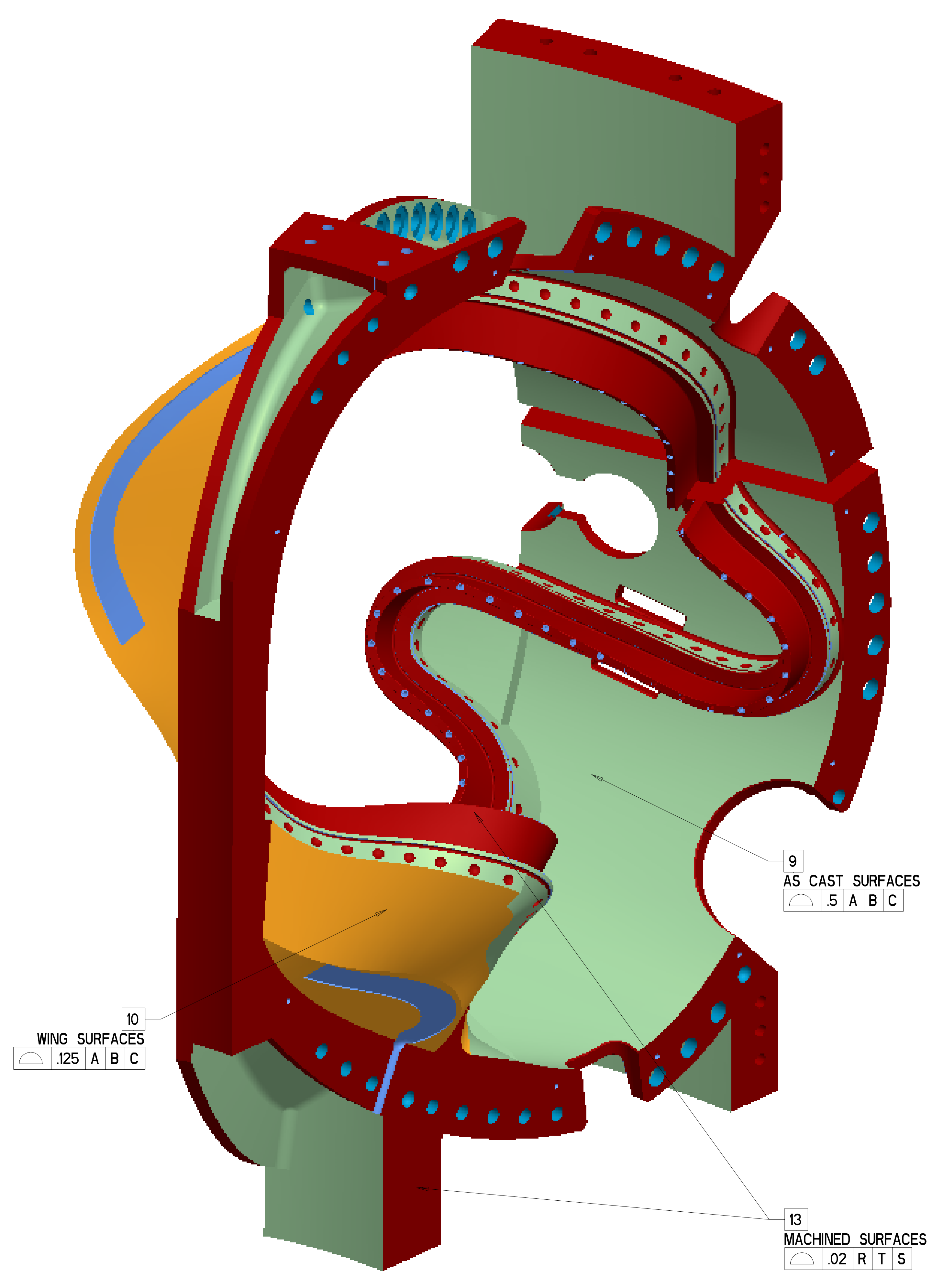

ISOMETRIC VIEW
 NOT TO SCALE

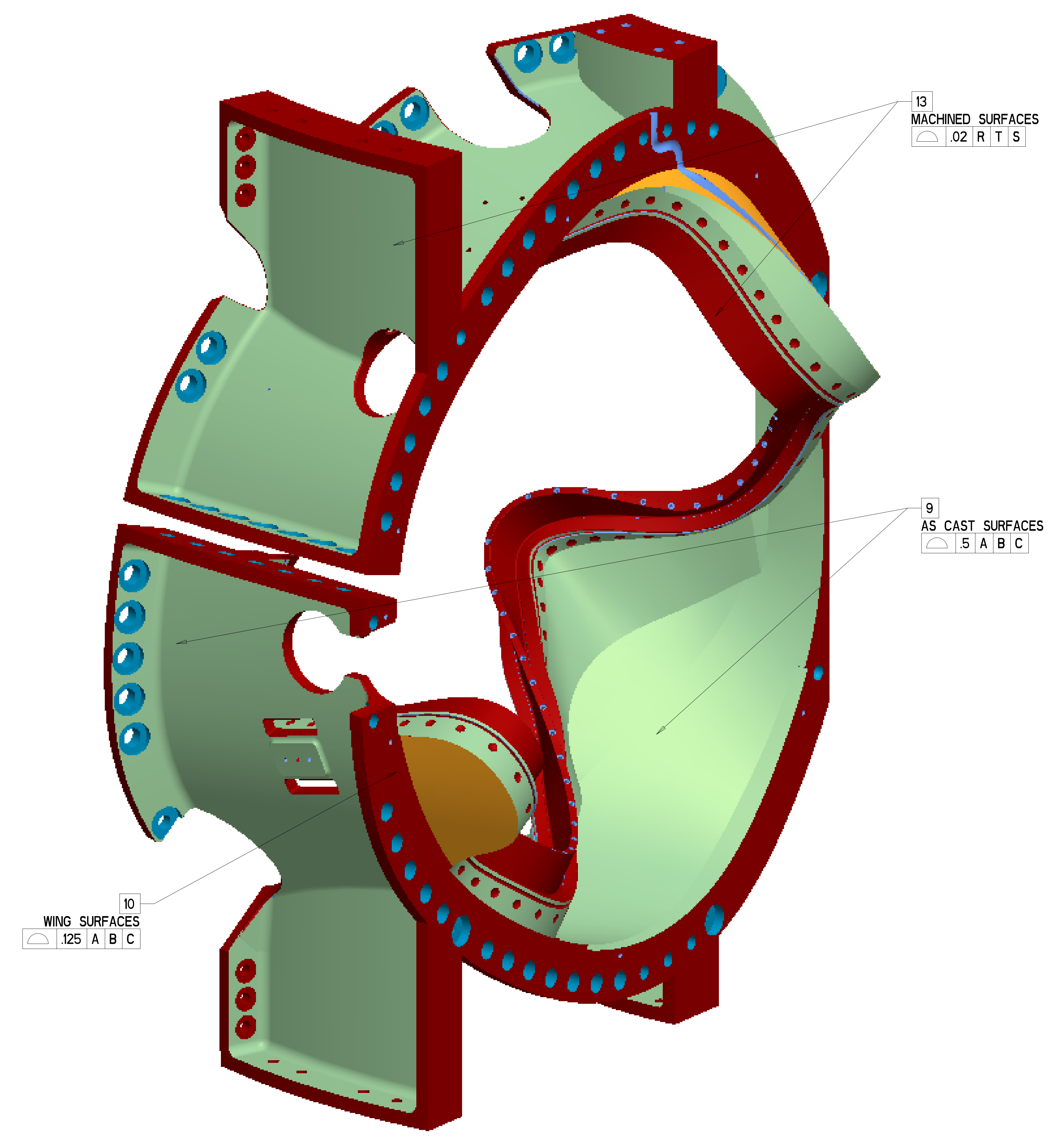

ISOMETRIC VIEW
 NOT TO SCALE

**RELEASED FOR
 FABRICATION / INSTALLATION**
 PPPL Drafting:

UT-BATTELLE		Oak Ridge National Laboratory managed for the DEPARTMENT OF ENERGY under U.S. GOVERNMENT contract DE-AC05-00OR22725 UT-BATTELLE, LLC, Oak Ridge, Tennessee					
NATIONAL COMPACT STELLARATOR EXPERIMENT							
PRODUCTION WINDING FORM TYPE-C							
VERSION NO.	PLANT	BLDG	FL	SHT OF	TYPE	CLASS	
10	X-10	5700	3	10	III	S	U
RELEASE LEVEL	SEI41-116					REV	4
Fabrication							

H
G
F
E
D
C
B
A

TABLE I WINDING CENTER SPLINE (FILE SEI4I-II6-WC.TXT)

Table with 4 columns: #, X, Y, Z. Contains 101 rows of coordinate data for the winding center spline.

TABLE II X-VECTOR SPLINE (FILE SEI4I-II6-XV.TXT)

Table with 4 columns: #, X, Y, Z. Contains 101 rows of coordinate data for the X-vector spline.

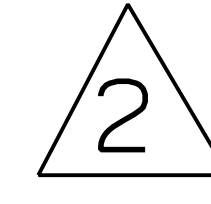

ALL POINT LOCATIONS ARE BASIC FOR NOTES AND PARTS LIST SEE SHEET I

RELEASED FOR FABRICATION / INSTALLATION PPPL Drafting:

UT-BATTELLE Oak Ridge National Laboratory logo and project information including 'NATIONAL COMPACT STELLARATOR EXPERIMENT' and 'PRODUCTION WINDING FORM TYPE-C'.

H G F E D C B A