

- NOTES:
- DRAWING PREPARED IN ACCORDANCE WITH ASME Y14.8M-1996.
 - INTERPRET DIMENSIONS AND TOLERANCES PER ANSI Y14.5M-1994.
 - DIMENSIONS ARE IN INCHES.
 - DRAWING DEPICTS FINAL MACHINED STATE OF ASSEMBLY DEFINED BY PRO/ENGINEER FILE SEI41-101.PRT.
 - UNLESS OTHERWISE SPECIFIED, DIMENSIONS ARE RELATED TO DATUM A- (PRIMARY X-Y PLANE, TOP) DATUM B- (SECONDARY Y-Z PLANE, SIDE) DATUM C- (TERTIARY X-Z PLANE, FRONT)
 - DIMENSIONS APPLY AT TEMPERATURE OF 20-30°C (68-86°F).
 - DIMENSIONS AND TOLERANCES EXCLUDE PROCESS MATERIAL ALLOWANCES WHICH MAY ADD MASS.
 - APPROXIMATE WEIGHT = 4983 LBS
 - MATCH DRILL OR REAM AS REQUIRED TO ACHIEVE RUNNING FIT BETWEEN PARTS AT ASSEMBLY.
 - LUBRICATE THREADED SURFACES WITH MOLYCOTE 321R PER MANUFACTURER'S INSTRUCTIONS.
 - SEE LATEST REVISION OF SPECIFICATION NCSX-CSPEC-141-03 FOR ADDITIONAL REQUIREMENTS.
 - BOND INSULATING SLEEVE (F/N 5) TO WINDING FORM (F/N 2) USING LOCTITE 411, PER MANUFACTURER'S INSTRUCTIONS.

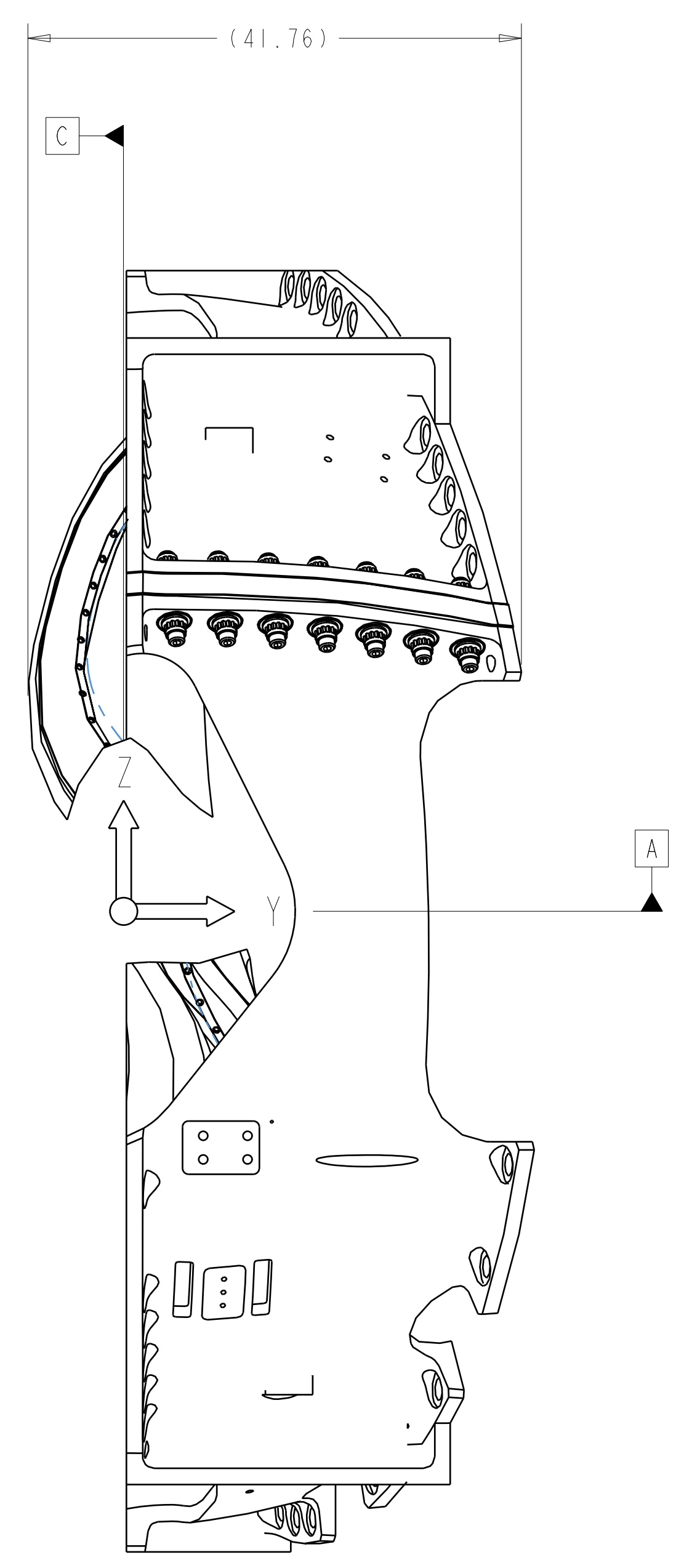
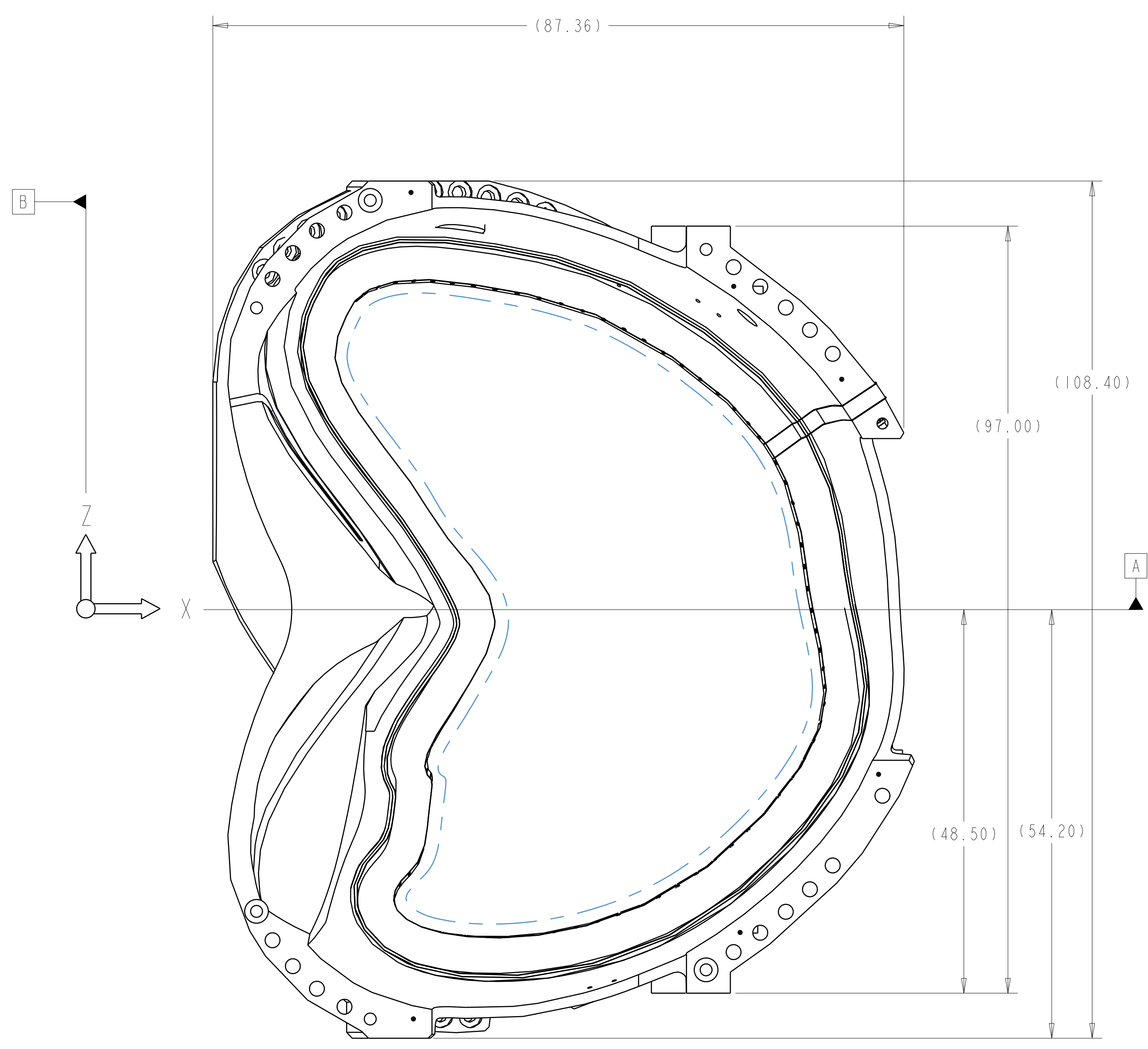
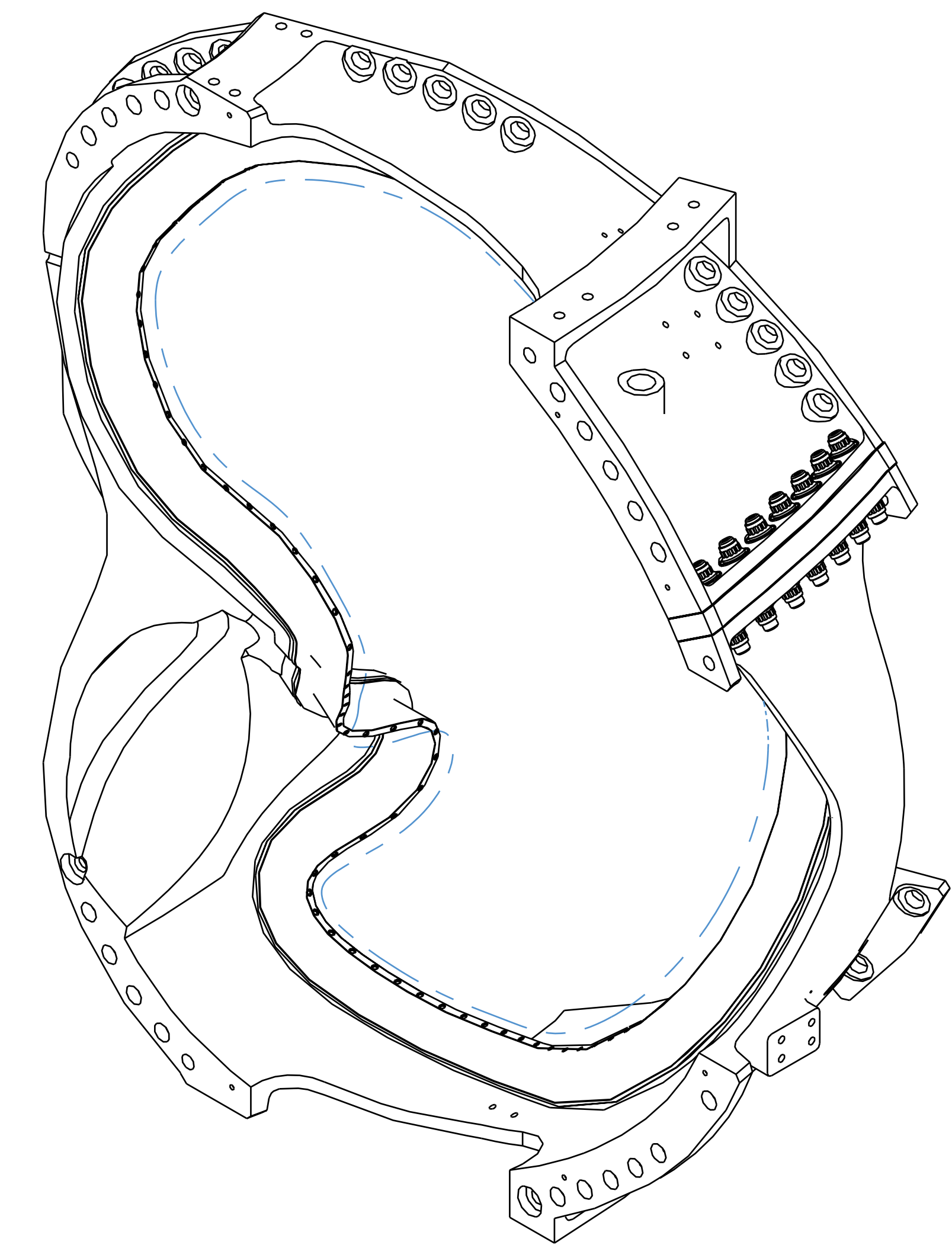
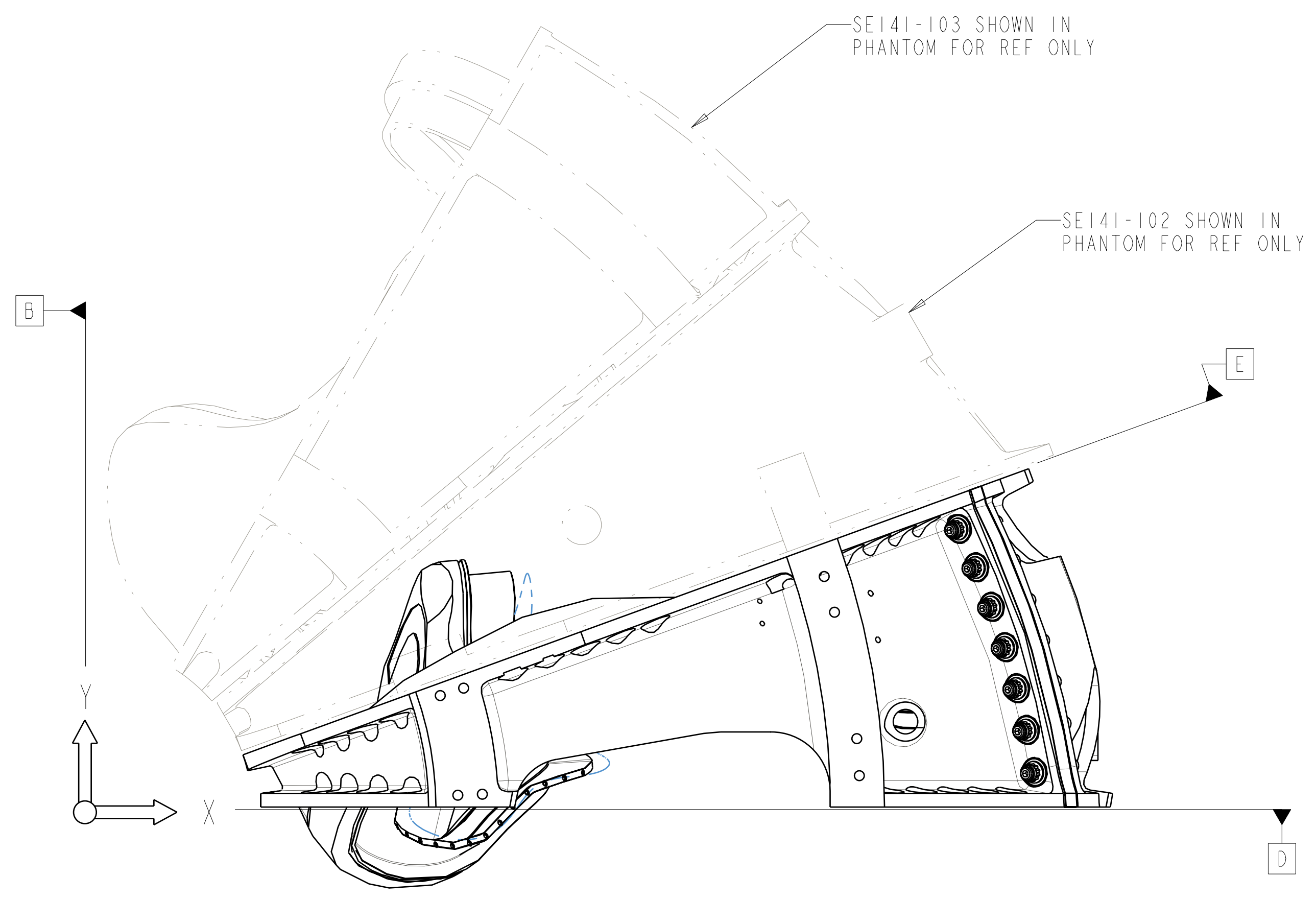

REV	DESCRIPTION	BY	DATE	CHK	DEPT	DATE	PE	REQ	DATE	ORNL	DOE	DATE
1	REVISED F/N 2 PER ECN-4903	DW	9/04	MJC			DEW					
REV	REVISION OR ISSUE PURPOSE											

QTY	PART OR IDENTIFYING NO	NOMENCLATURE OR DESCRIPTION	MATERIAL	SPECIFICATION	FIND NO
14	DS141-079	FLAT WASHER			9
14	DS141-060	NUT, 12PT HEX 1.375-6UNC-2B			8
14	DS141-038	INSULATING WASHER			7
7	DS141-036	STUD, 1.375-6UNC-2A X 9 LG			6
14	-5	MCWF INSULATING SLEEVE TYPE-A	G11CR	NEMA LI 1 - 1998	5
1	-4	INSULATING SHEET TYPE-A	G11CR	NEMA LI 1 - 1998	4
1	SEI41-048	POL BREAK SHIM ASSEMBLY TYPE-A			3
1	SEI41-114	PRODUCTION WINDING FORM TYPE-A			2
AR	X	-1	MOD COIL WINDING FORM ASSEMBLY TYPE-A		1

← CAGE CODE PART OR IDENTIFYING NO NEXT ASSEMBLY

SCALE .10

NO REPRESENTATION OR WARRANTY, EXPRESSED OR IMPLIED, IS MADE AS TO THE ACCURACY, COMPLETENESS OR USEFULNESS OF THE INFORMATION OR STATEMENTS CONTAINED IN THESE DRAWINGS, OR THAT THE USE OR DISCLOSURE OF ANY INFORMATION, APPARATUS, METHOD OR PROCESS DISCLOSED IN THESE DRAWINGS MAY NOT INFRINGE PRIVATE RIGHTS OF OTHERS. NO LIABILITY IS ASSUMED WITH RESPECT TO THE USE OF, OR FOR DAMAGES RESULTING FROM THE USE OF, ANY INFORMATION, APPARATUS, METHOD OR PROCESS DISCLOSED IN THESE DRAWINGS. DRAWINGS MADE AVAILABLE FOR INFORMATION TO BIDDER ARE NOT TO BE USED FOR OTHER PURPOSES, AND ARE TO BE RETURNED UPON REQUEST OF THE FORWARDING CONTRACTOR.

P THIS DRAWING PRODUCED ON PRO-ENGINEER

SCALE NOTED	DES T BROWN 6-30-04	UT-BATTELLE Oak Ridge National Laboratory managed for the DEPARTMENT OF ENERGY under U.S. GOVERNMENT contract DE-AC05-00OR22725 UT-BATTELLE, LLC, Oak Ridge, Tennessee PROJECT NAME NATIONAL COMPACT STELLARATOR EXPERIMENT										
TOLERANCES UNLESS OTHERWISE SPECIFIED	DRW P MILLER 6-30-04											
FRACTIONS	CHK M COLE 6-30-04											
XX DECIMALS ±.01	PE D WILLIAMSON 6-30-04											
XXX DECIMALS ±.005	CR :	MOD COIL WINDING FORM ASSEMBLY TYPE-A										
ANGLES ±0°15'	PJ :											
BREAK SHARP EDGES .06 MAX	RED :											
FINISH .125 UNLESS OTHERWISE SPECIFIED	PPPL DRFT J SIEGEL 6-30-04											
REV	DESCRIPTION	BY	DATE	CHK	DEPT	DATE	PE	REQ	DATE	ORNL	DOE	DATE
1	REVISED F/N 2 PER ECN-4903	DW	9/04	MJC			DEW					
REV	REVISION OR ISSUE PURPOSE											

PPPL DRFT J SIEGEL 6-30-04

VERSION NO.	PLANT	BLDG	FL	SHT OF	TYPE	CLASS
4+	X-10	5700	3	1 2	S	U
RELEASE LEVEL	SEI41-101					
WIP						

FOR NOTES AND PARTS LIST SEE SHEET 1

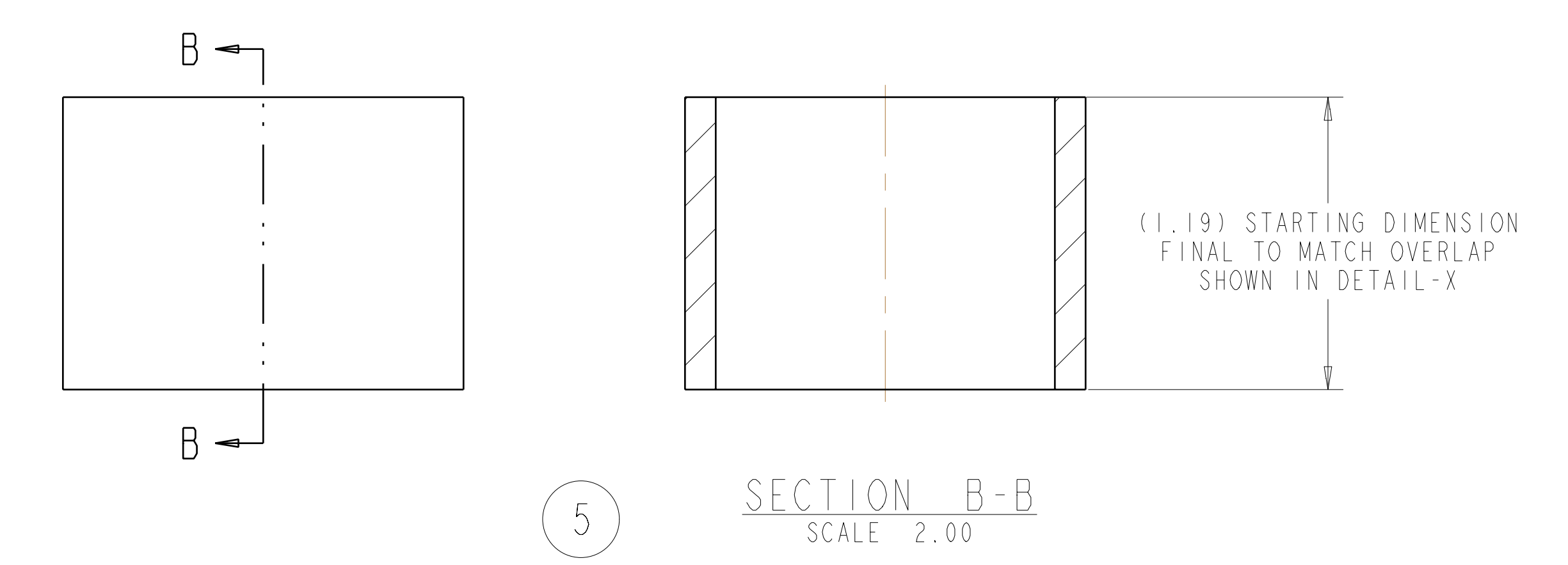
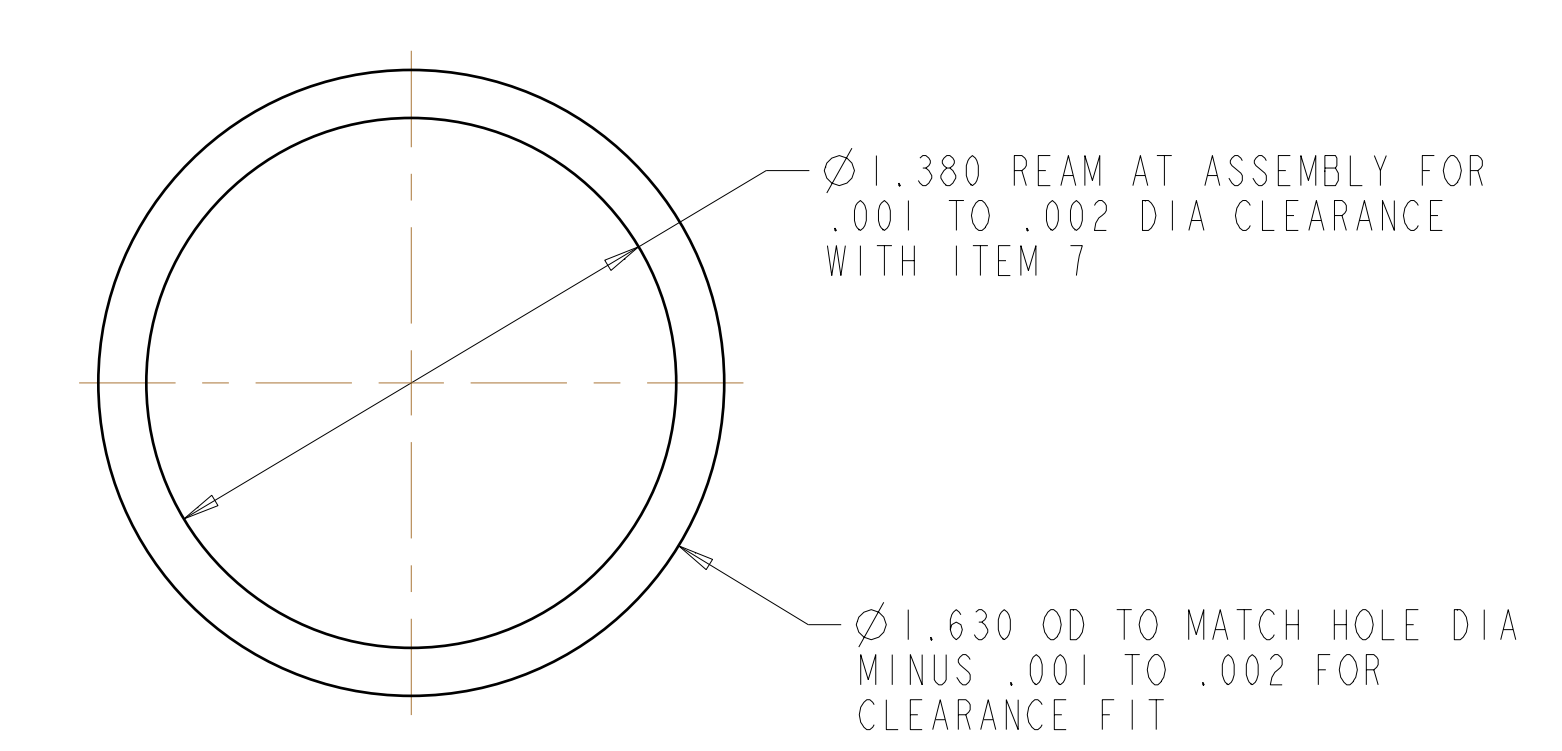
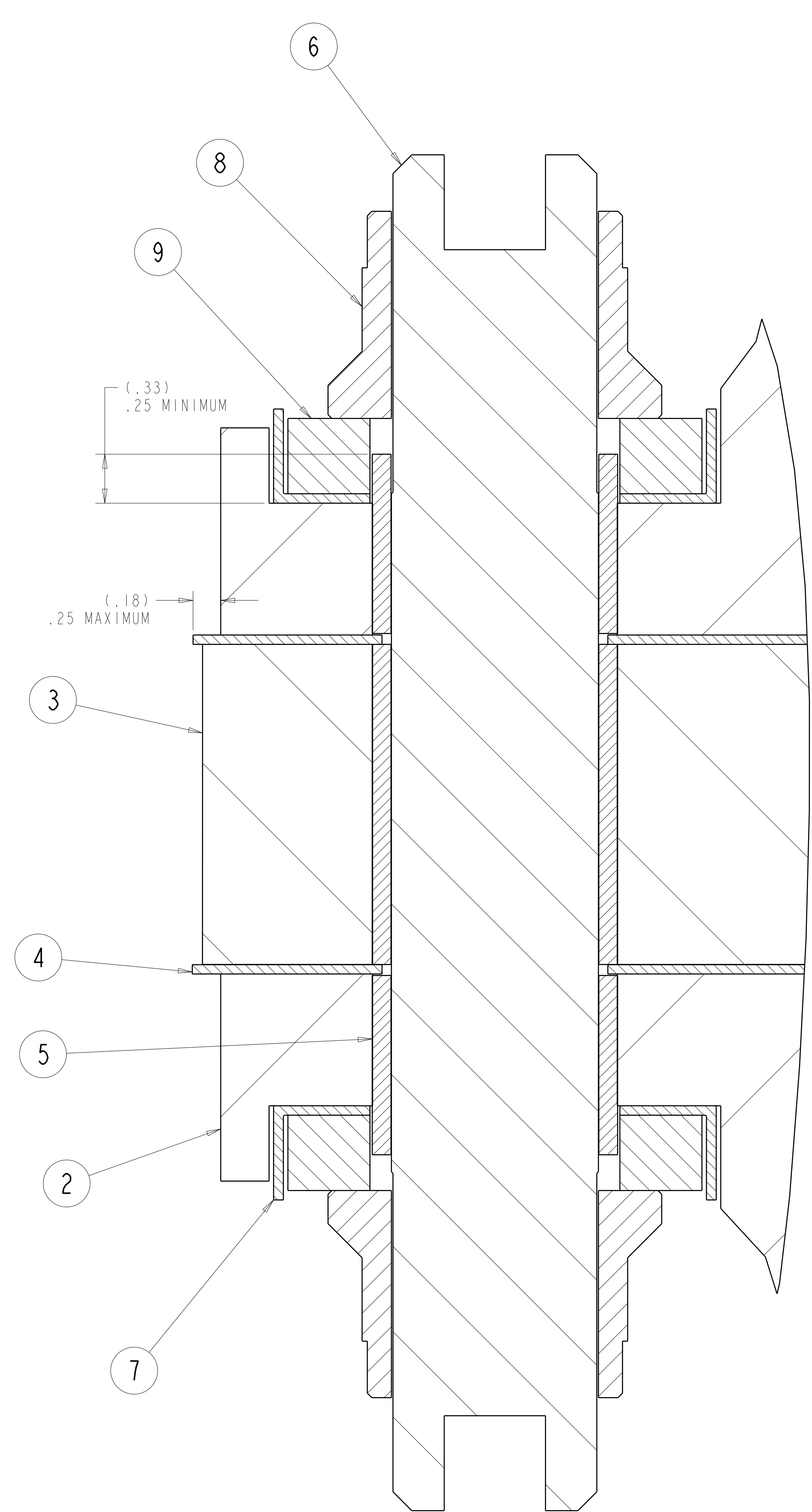
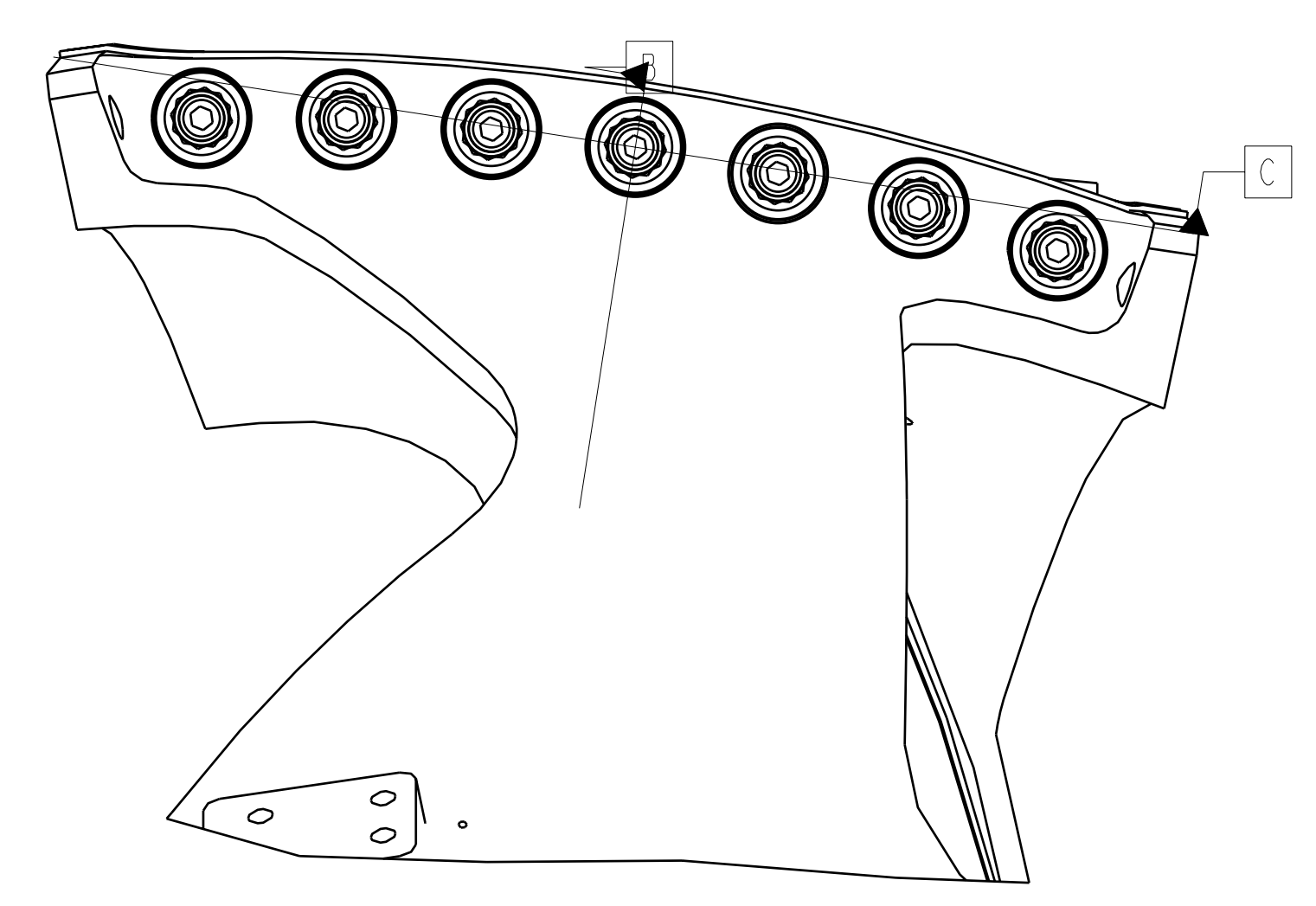
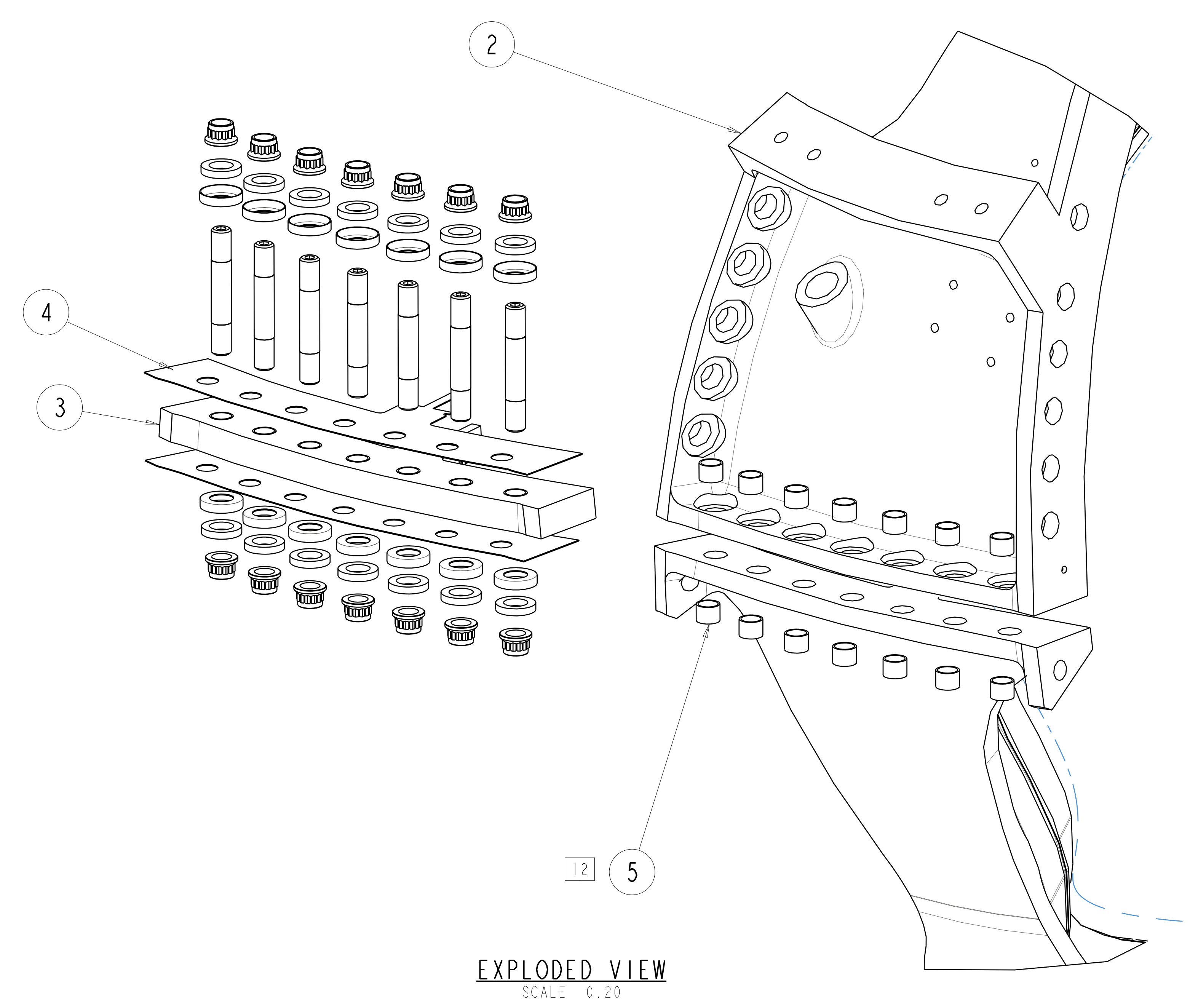
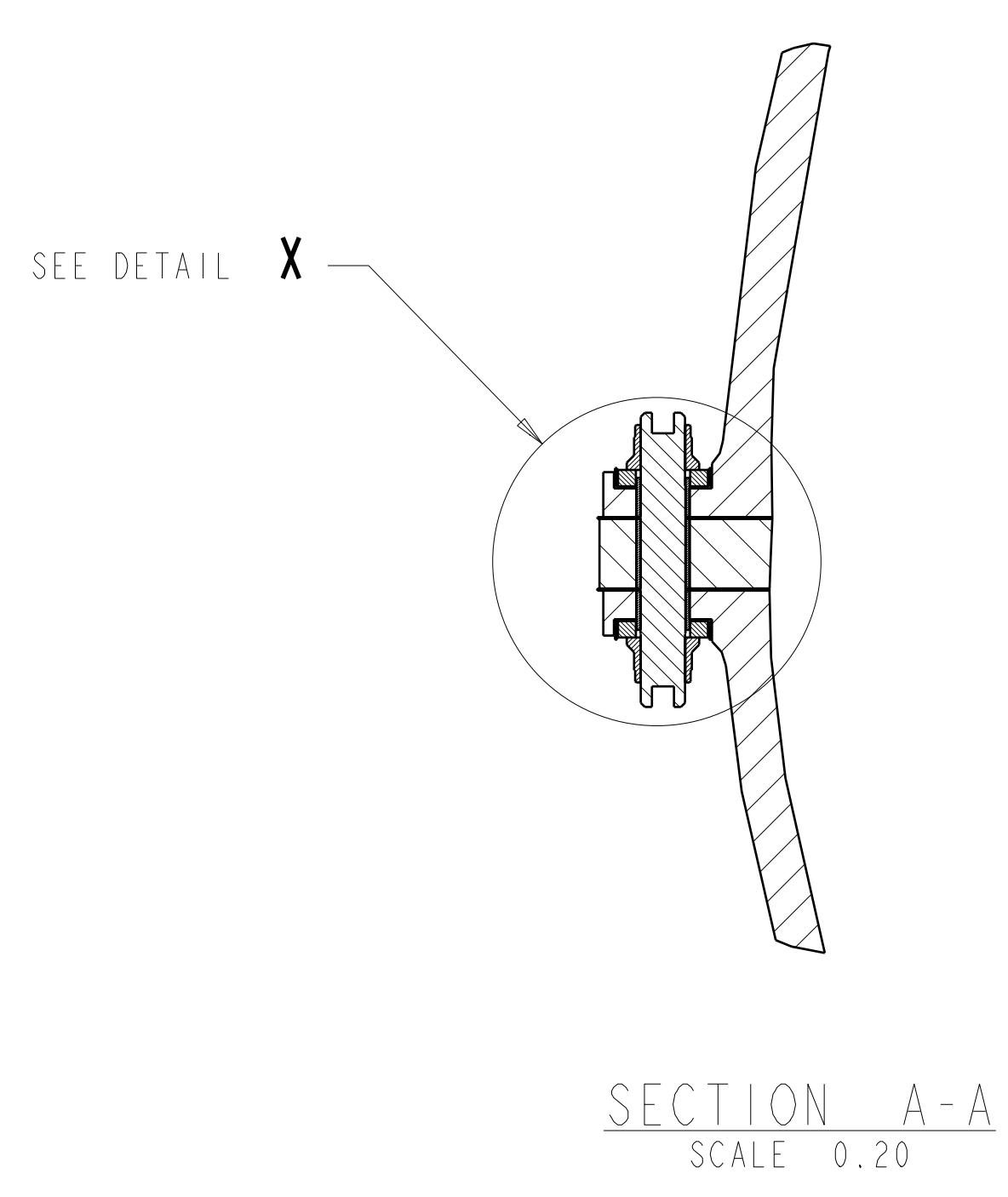
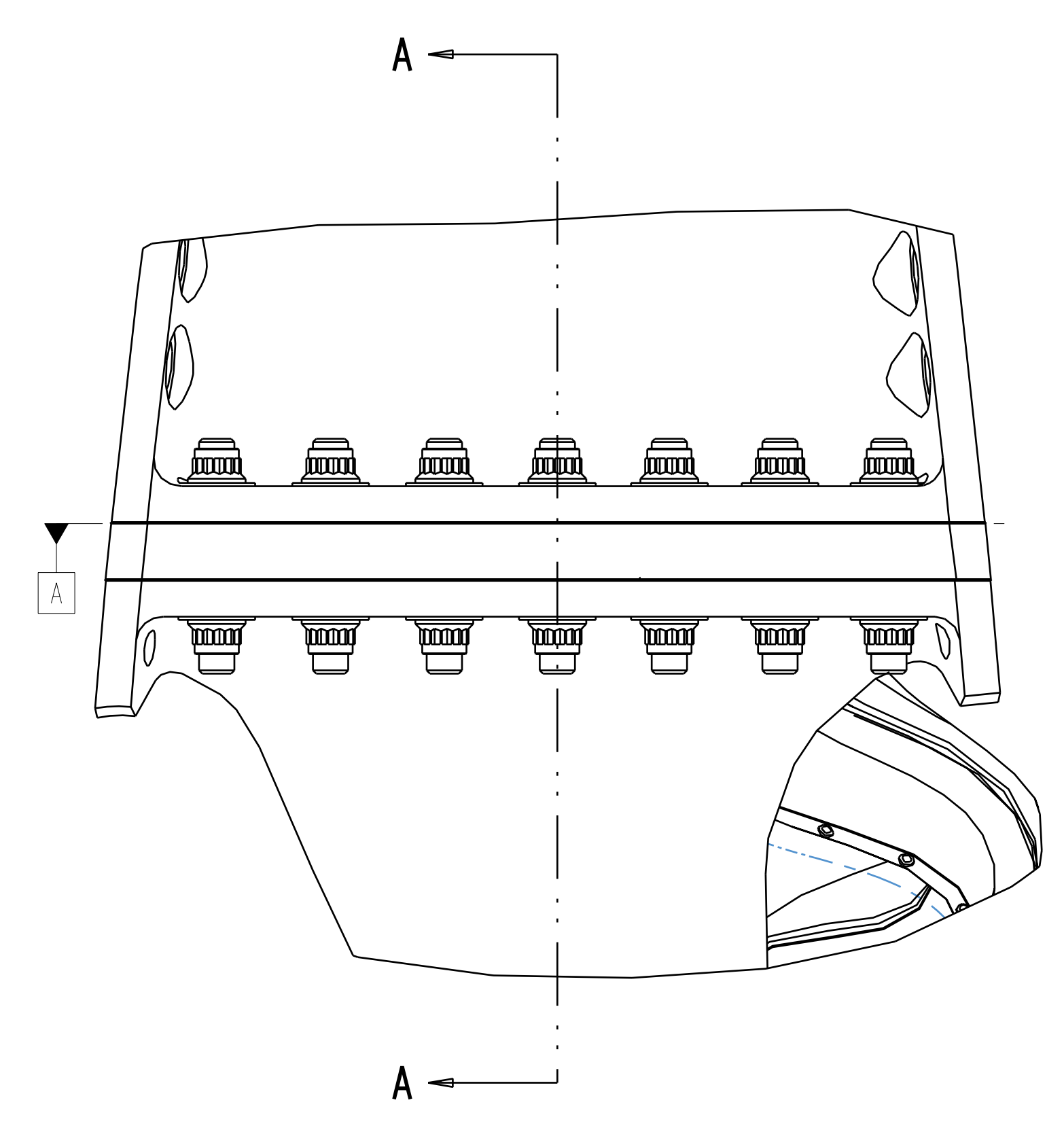

Oak Ridge National Laboratory managed for the DEPARTMENT OF ENERGY under U.S. GOVERNMENT contract DE-AC05-00OR22725 UT-BATTELLE, LLC, Oak Ridge, Tennessee PROJECT NAME							
UT-BATTELLE NATIONAL COMPACT STELLARATOR EXPERIMENT							
MOD COIL WINDING FORM ASSEMBLY TYPE-A							
VERSION NO.	PLANT	BLDG	FL	SHT OF	TYPE	CLASS	
4+	X-10	5700	3	2	S	U	
RELEASE LEVEL	SEI41-101						REV
WIP							I

H
G
F
E
D
C
B
A

SEI41-101