

- NOTES:
1. INTERPRET DIMENSIONS AND TOLERANCES PER ANSI Y14.5M.
 2. DIMENSIONS ARE IN INCHES.
 3. FABRICATION, INSPECTION, AND TESTING SHALL BE PERFORMED IN ACCORDANCE WITH SPECIFICATION NCSX-CSPEC-121-02 AND STATEMENT OF WORK NCSX-SOW-121-03.

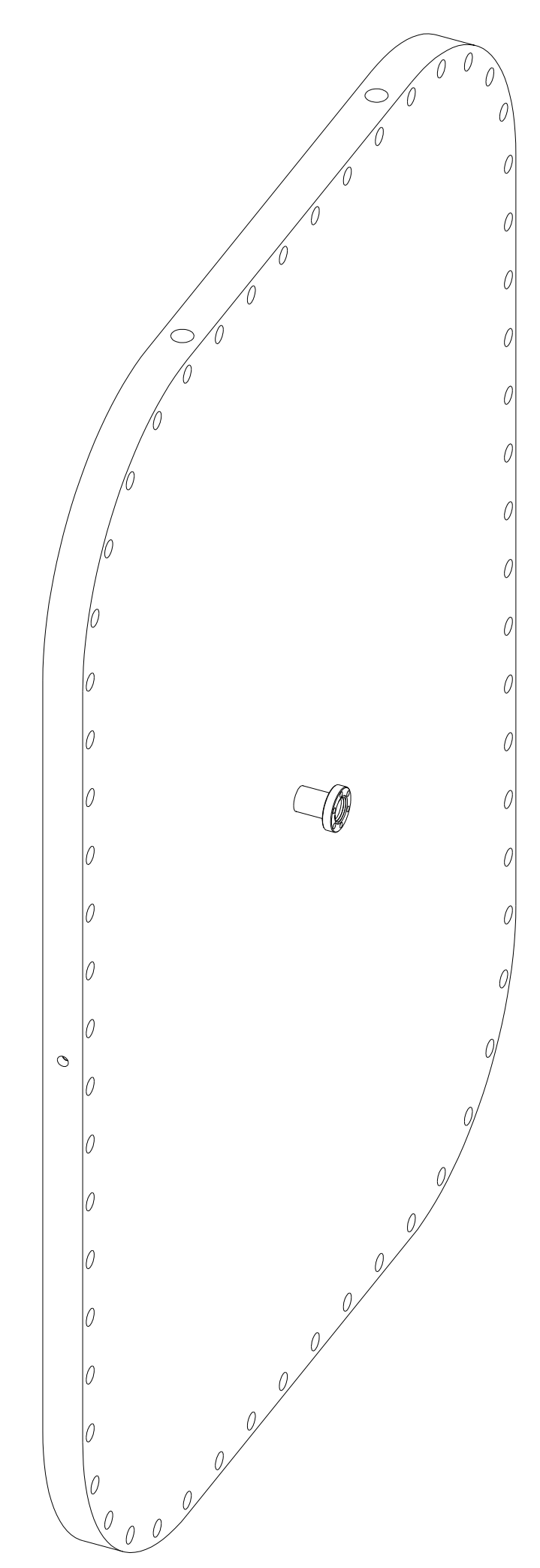

ISOMETRIC VIEW

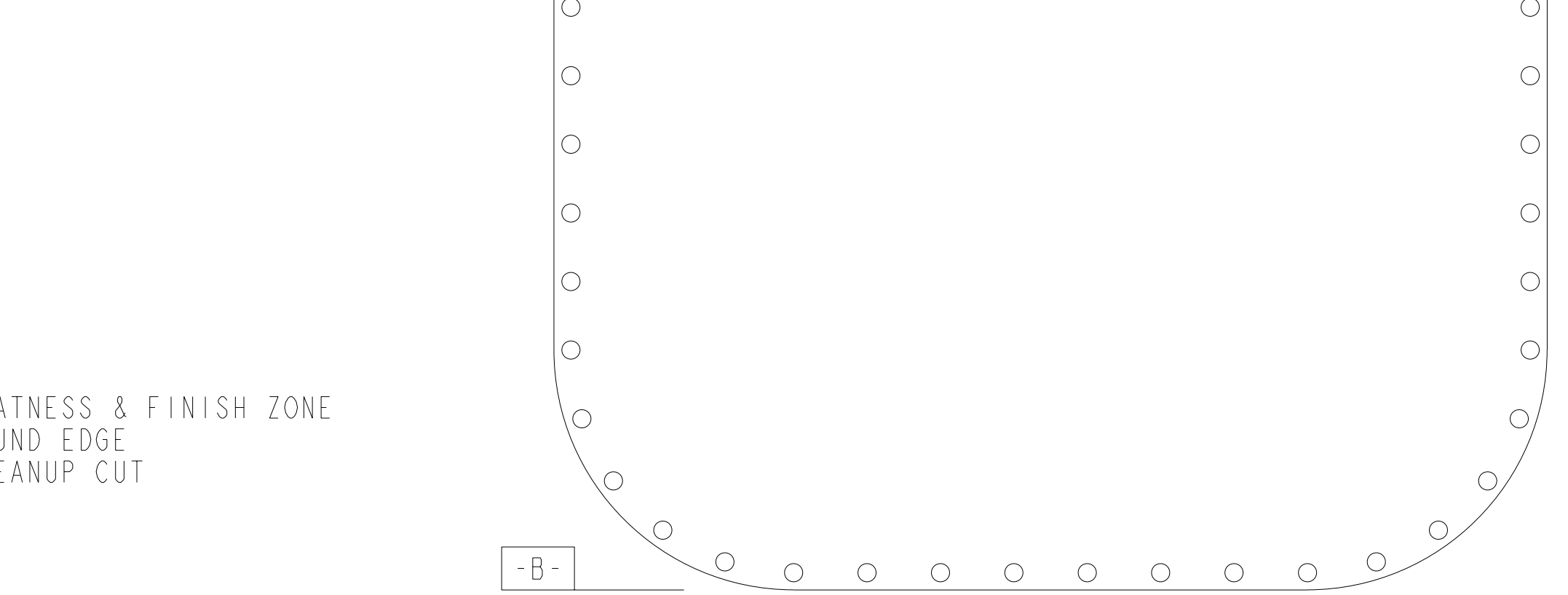
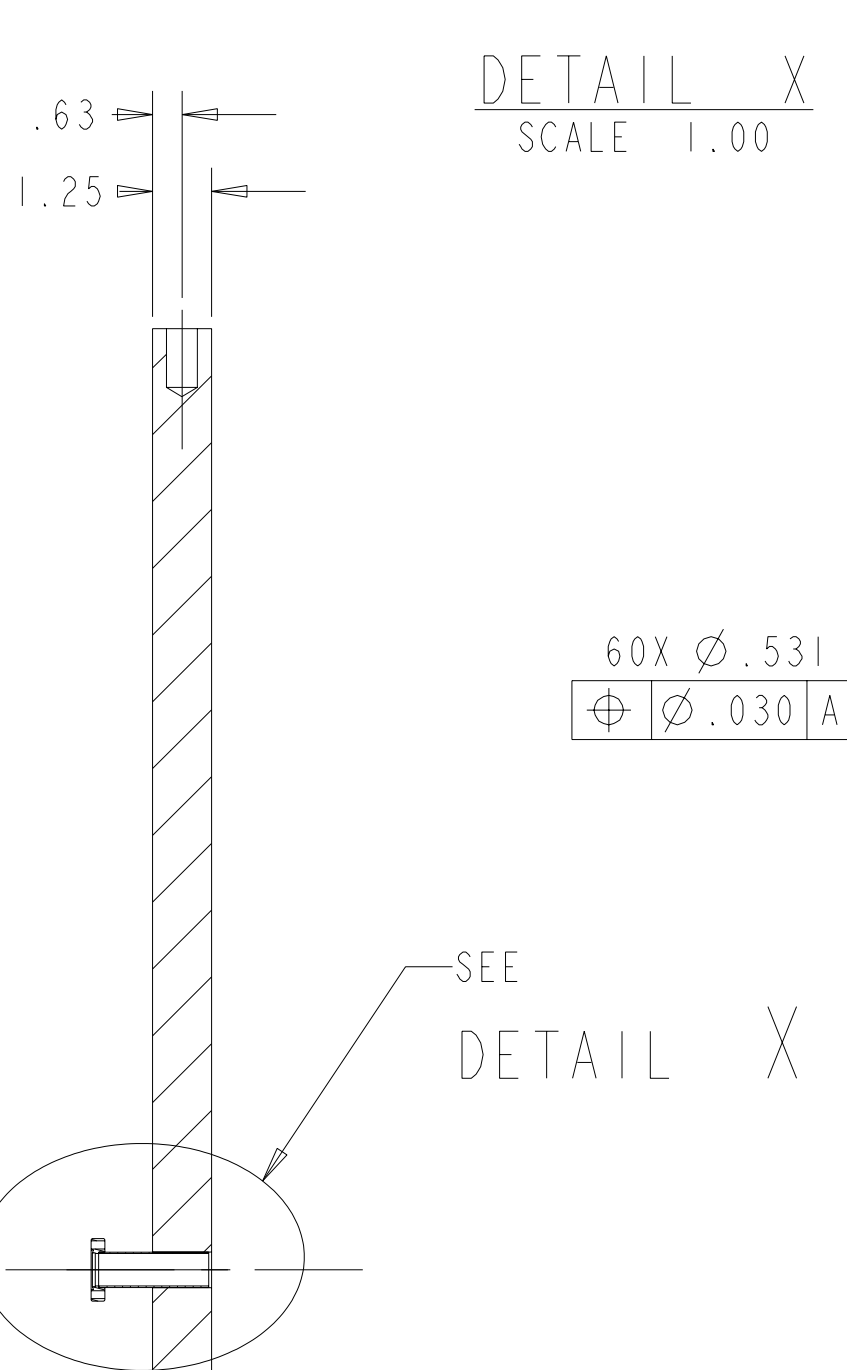
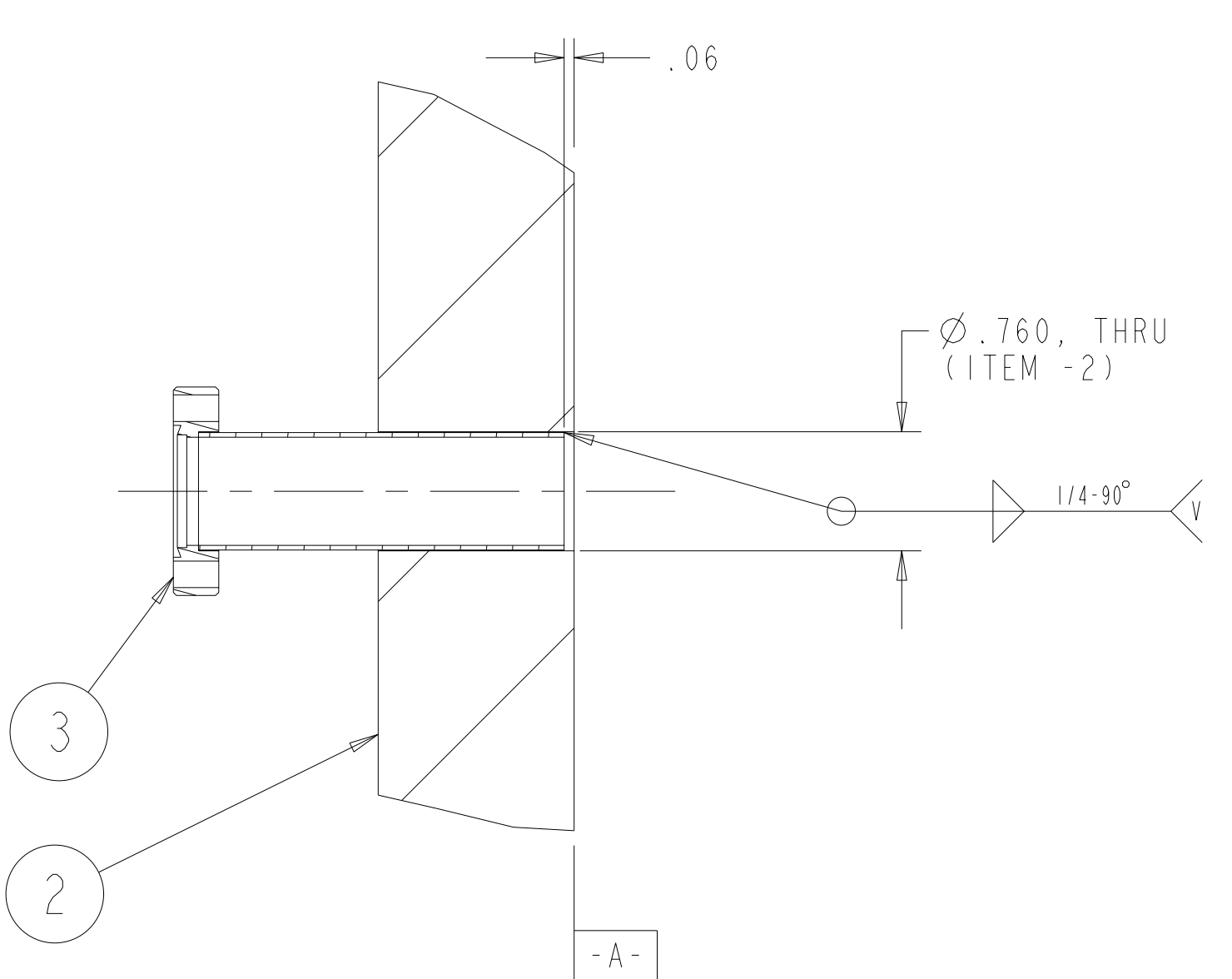
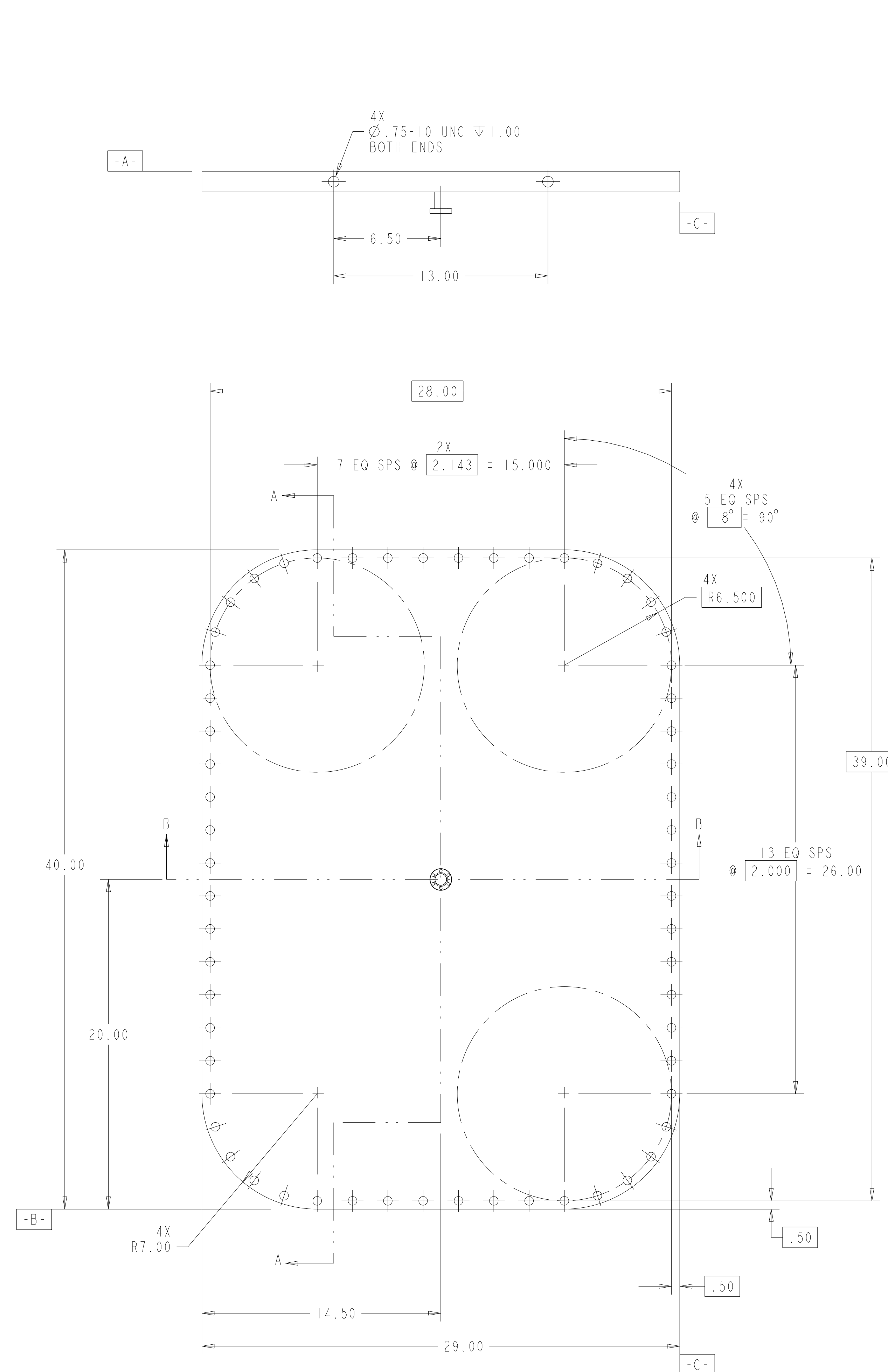
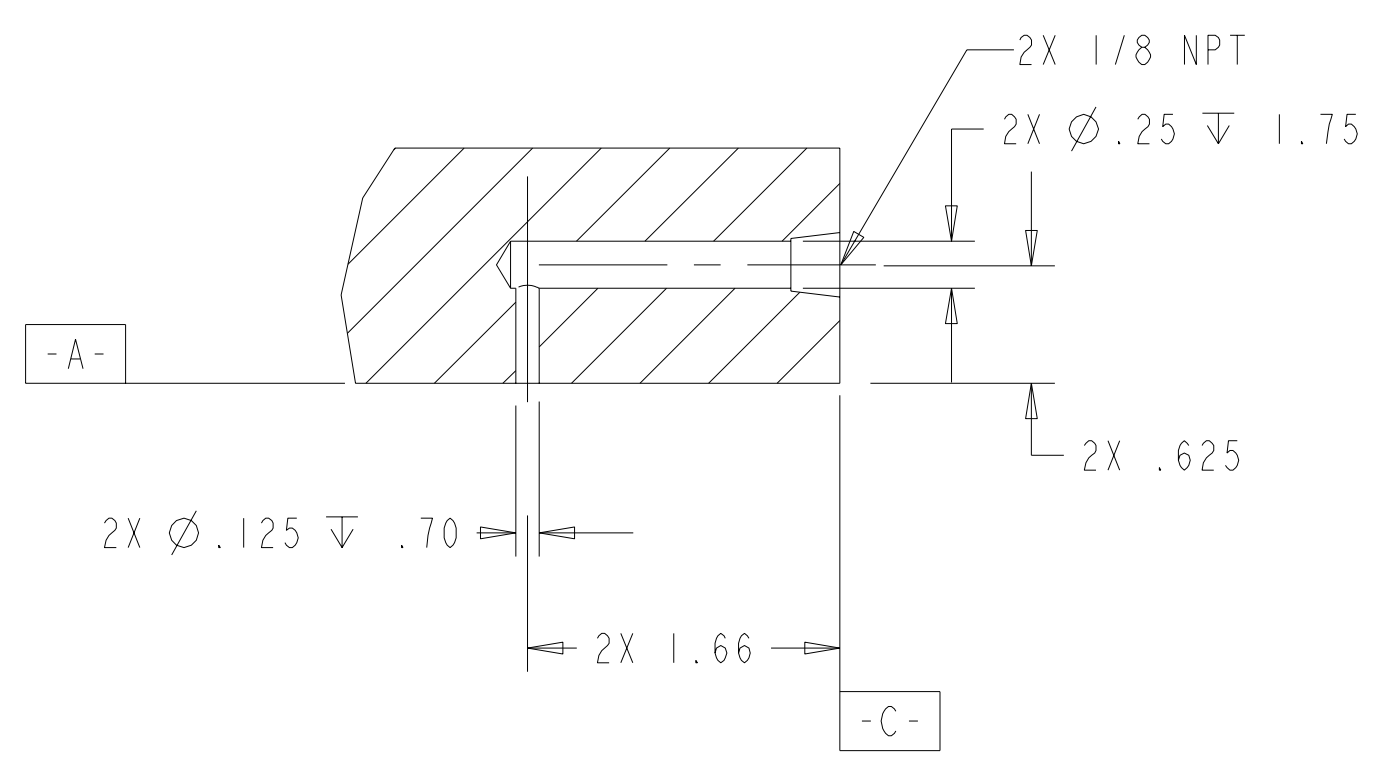
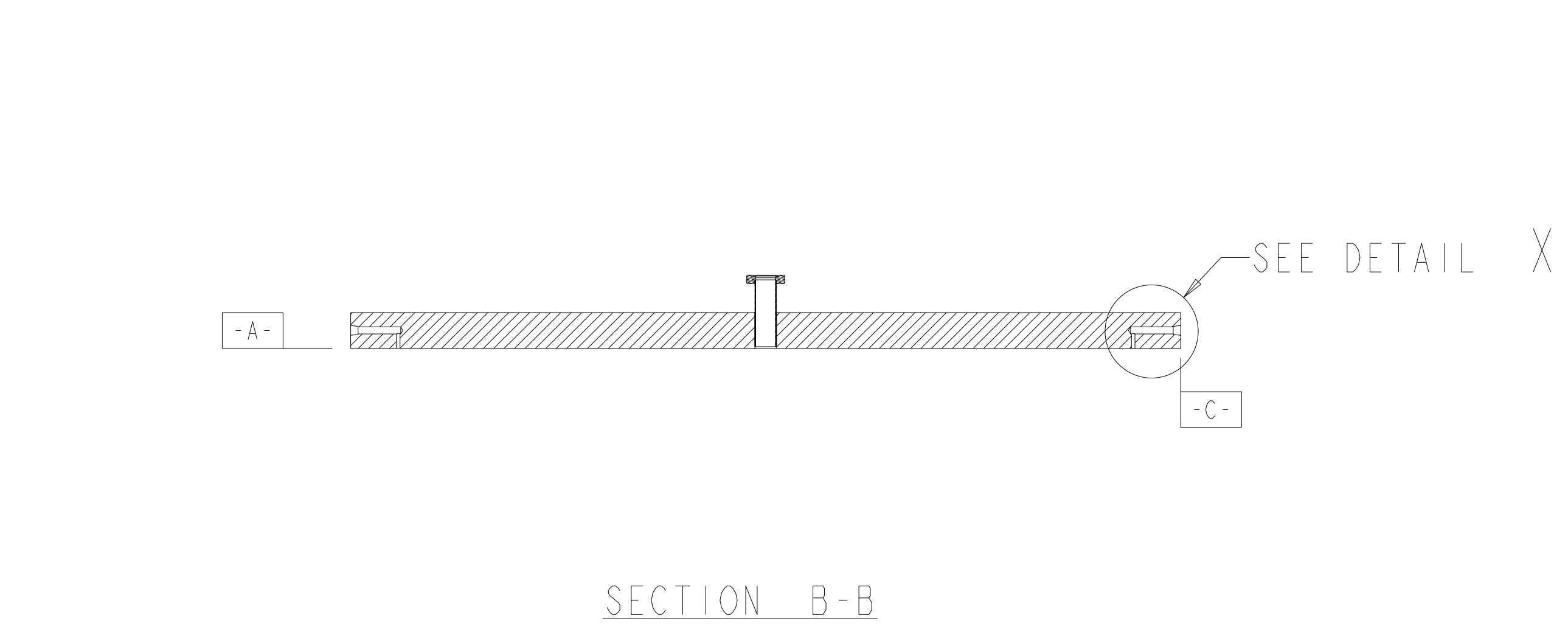

SCALE: .25

DETAIL X SCALE: 1.00

WELDING ENGINEER
APPROVED R. PARSELLS DATE: 6/09

RELEASED FOR FABRICATION / INSTALLATION
PPPL Drafting:

AR	QTY	DESCRIPTION	MATERIAL	SPECIFICATION	FIND NO	
AR	-4	WELD FILLER METAL			4	
I	-3	HALF NIPPLE 1/3 DEL-SEAL CF CUSTOM LENGTH = 2.50"	NDC VACUUM PRODUCTS CORP. 23842 CABOT BOULEVARD, HAYWARD CA. 94545-1615		3	
I	-2	PORT 4 COVER TEST FLANGE	316L SST		2	
AR	-1	PORT 4 COVER TEST FLANGE WELDMENT			1	
SE 20-004	-1	CAGE CODE				
		PART OR IDENTIFYING NO	NOMENCLATURE OR DESCRIPTION	MATERIAL	SPECIFICATION	FIND NO
		← NEXT ASSEMBLY	PARTS LIST			

NO REPRESENTATION OR WARRANTY, EXPRESSED OR IMPLIED, IS MADE AS TO THE ACCURACY, COMPLETENESS OR USEFULNESS OF THE INFORMATION OR STATEMENTS CONTAINED IN THESE DRAWINGS, OR THAT THE USE OR DISCLOSURE OF ANY INFORMATION, APPARATUS, METHOD OR PROCESS DISCLOSED IN THESE DRAWINGS MAY NOT INFRINGE PRIVATE RIGHTS OF OTHERS. NO LIABILITY IS ASSUMED WITH RESPECT TO THE USE OF, OR FOR DAMAGES RESULTING FROM THE USE OF, ANY INFORMATION, APPARATUS, METHOD OR PROCESS DISCLOSED IN THESE DRAWINGS. DRAWINGS MADE AVAILABLE FOR INFORMATION TO BIDDERS ARE NOT TO BE USED FOR OTHER PURPOSES, AND ARE TO BE RETURNED UPON REQUEST OF THE FORWARDING CONTRACTOR.

P THIS DRAWING PRODUCED ON PRO-ENGINEER

REV	DESCRIPTION	BY	DATE	CHK	DEPT	DATE	PE	REQ	DATE	ORNL	DOE	DATE

SCALE NOTED	DES PL GORANSON 8/03
TOLERANCES UNLESS OTHERWISE SPECIFIED	DRW G.H. JONES 8/03
FRACTIONS	CHK D SPARKS 6/04
XX DECIMALS ±.01	SECT :
XXX DECIMALS ±.005	DEPT :
ANGLES ±0°15'	PE :
BREAK SHARP EDGES .06 MAX	CR :
FINISH .125 UNLESS OTHERWISE SPECIFIED	PJ :
	REQ :
	PPPL DRFT J. SIEGEL 6/04
	VERSION NO. 15
	PLANT X-10
	BLDG 5700
	FL 03
	SHT 1
	TYPE 1
	CLASS A
	RELEASE LEVEL Fabrication
	DATE

UT-BATTELLE		Oak Ridge National Laboratory managed for the DEPARTMENT OF ENERGY under U.S. GOVERNMENT CONTRACT DE-AC05-00OR22725 UT-BATTELLE, LLC, Oak Ridge, Tennessee	
PROJECT NAME			
NATIONAL COMPACT STELLARATOR EXPERIMENT			
VACUUM VESSEL			
PORT 4 COVER TEST FLANGE WELDMENT			
VERSION NO.	PLANT	BLDG	FL
15	X-10	5700	03
SHT	TYPE	CLASS	REV
1	1	A	U
RELEASE LEVEL Fabrication			REV 0
SE122-149			