

ISOMETRIC VIEW

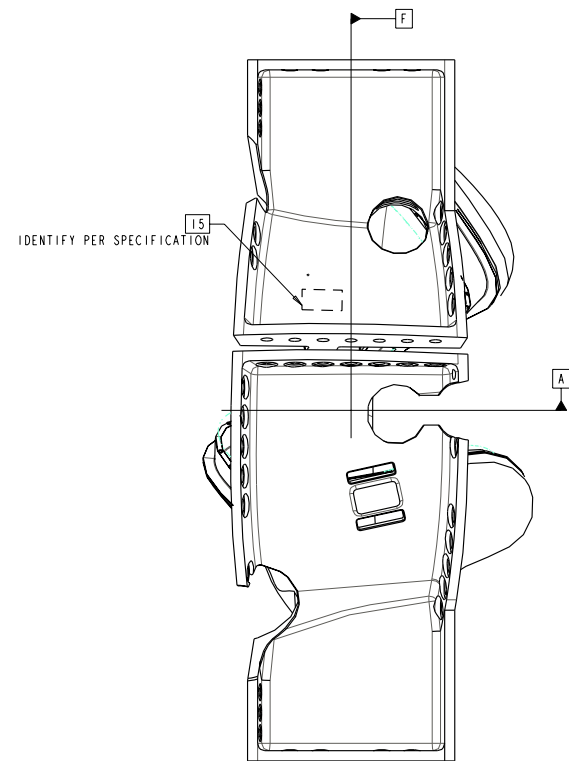
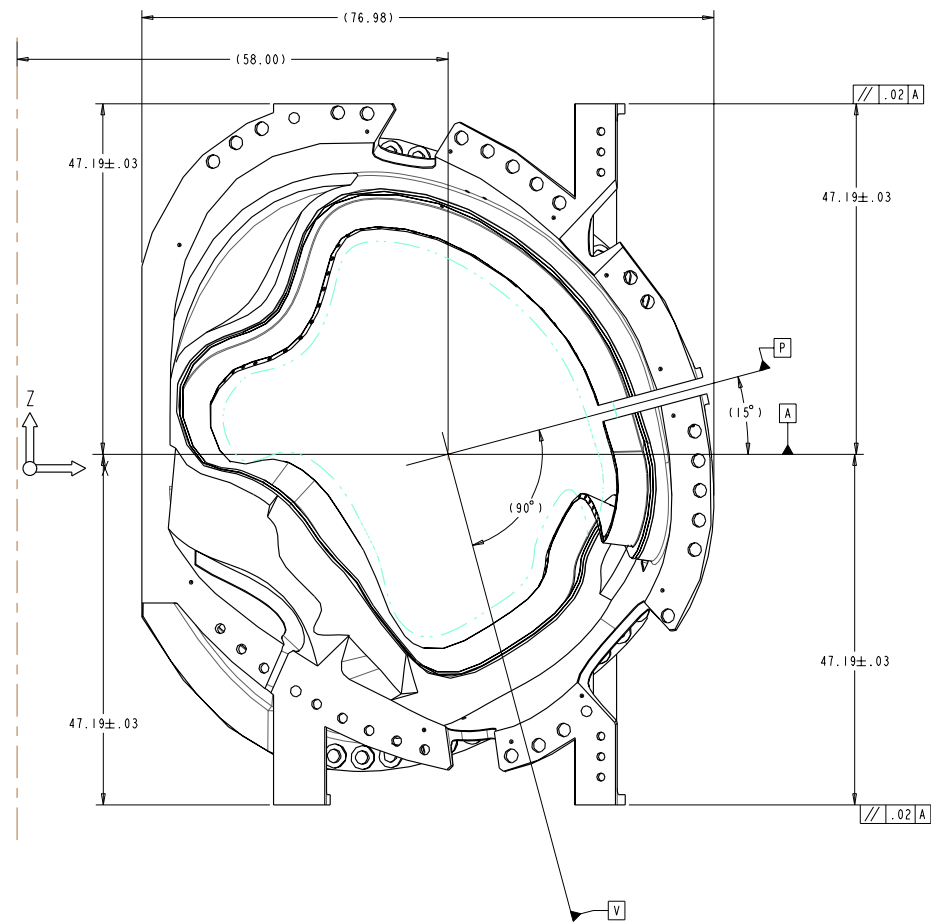

NOTES:

1. DRAWING PREPARED IN ACCORDANCE WITH ASME Y14.8M-1996.
2. INTERPRET DIMENSIONS AND TOLERANCES PER ANSI Y14.5M-1994.
3. DIMENSIONS ARE IN INCHES.
4. DRAWING DEPICTS FINAL MACHINED STATE OF PART DEFINED BY PRO/ENGINEER FILE SE141-116.PRT.
5. UNLESS OTHERWISE SPECIFIED, DIMENSIONS ARE RELATED TO DATUM A - (PRIMARY X-Y PLANE, TOP)  
DATUM B - (SECONDARY Y-Z PLANE, SIDE)  
DATUM C - (TERTIARY X-Z PLANE, FRONT)
6. DIMENSIONS APPLY AT TEMPERATURE OF 20-30°C (68-86°F)
7. DIMENSIONS AND TOLERANCES EXCLUDE PROCESS MATERIAL ALLOWANCES WHICH MAY ADD MASS.
8. APPROXIMATE WEIGHT = 4898 LBS.  
WEIGHT OF FINISHED PART NOT TO EXCEED 6000 LBS.
9. UNLESS OTHERWISE SPECIFIED, AS-CAST SURFACE PROFILE TOLERANCE = +/- .25 - .1 INCH, WITH EXEMPTION FOR INTERSECTING SURFACES WHERE FILLETS ARE EXPECTED. MIN FILLET AND CORNER RADII = 0.5 +/- 0.1 IN.
10. DESIGNATED SURFACE REGIONS HAVE PROFILE TOLERANCE = +/- 0.125 IN.
11. MIN THICKNESS PER CAD GEOMETRY, TOLERANCE = +0.25 IN / -0.0 IN.
12. PARTING LINE EDGES, FLASH, GATES, RUNNER, AND RISER EXTENSIONS 0.25 IN MAX
13. UNLESS OTHERWISE SPECIFIED, MACHINED SURFACE PROFILE TOLERANCE = +/- 0.01 IN.
14. BACK SPOTFACE ALL THRU HOLES MINIMUM TO CLEAN UP.
15. SEE LATEST REVISION OF SPECIFICATION NCSX-CSPEC-141-03 FOR ADDITIONAL REQUIREMENTS.

AR	X	SE141-116	WINDING FORM TYPE-C	CAST SS	SEE NOTE #15	I
CAGE CODE	PART OR IDENTIFYING NO	NOMENCLATURE OR DESCRIPTION	MATERIAL	SPECIFICATION	FIND NO	
←	←	←	←	←	←	←

SCALE .125

REV	DESCRIPTION	BY	DATE	CHK	DEPT	DATE	PE	REQ	DATE	ORNL	DOE	DATE
3	REVISED DRAWING AND MODEL PER ECN 4944	GLL	1/05	MJC	DEW							
2	SHEET 11 REMOVED TABLES 111 & 117	GLL	9/04	MJC	DEW							
	SHEET 2: DETAIL B REMOVED SPHERICAL SEATS											
	MODIFIED TEE RELIEF TO .1 R; .03 CHAMFER											
	WAS .06; PER ECN-4903											
1	REVERSED UPPER INB VERT SUPP POCKET.	DEW	7/04	TGB	DEW							
	CHANGED LN2 INLET/OUTLET HOLE DIAMETER.											
	MODIFIED LEAD BLOCK DIMS PER ECN-4883.											

SCALE	NOTED	DES	T BROWN	5-5-04
TOLERANCES UNLESS OTHERWISE SPECIFIED:		DRW	P MILLER	5-5-04
FRACTIONS:		CHK	M. COLE	6-25-04
XX DECIMALS ±.01		SECT:		
XXX DECIMALS ±.005		PE	D. WILLIAMSON	6-25-04
ANGLES ±0°15'		CR:		
BREAK SHARP EDGES .06 MAX		REQ:		
FINISH OTHERWISE SPECIFIED		PPPL	DRFT J. SIEGEL	6-25-04

Oak Ridge National Laboratory managed for the DEPARTMENT OF ENERGY under U.S. GOVERNMENT contract # DE-AC05-80OR21400 UT-BATTELLE, LLC, Oak Ridge, Tennessee						
<b>UT-BATTELLE</b>						
NATIONAL COMPACT STELLARATOR EXPERIMENT						
PRODUCTION WINDING FORM TYPE-C						
VERSION NO. 6	PLANT X-10	BLDG 5700	FL 3	SHT 11	TYPE U	CLASS
RELEASE LEVEL WIP	SE141-116		REV 3			

NO REPRESENTATION OR WARRANTY, EXPRESSED OR IMPLIED, IS MADE AS TO THE ACCURACY, COMPLETENESS OR USEFULNESS OF THE INFORMATION OR STATEMENTS CONTAINED IN THESE DRAWINGS, OR THAT THE USE OR DISCLOSURE OF ANY INFORMATION, APPARATUS, METHOD OR PROCESS DISCLOSED IN THESE DRAWINGS MAY NOT INFRINGE PRIVATE RIGHTS OF OTHERS. NO LIABILITY IS ASSUMED WITH RESPECT TO THE USE OF, OR FOR DAMAGES RESULTING FROM THE USE OF, ANY INFORMATION, APPARATUS, METHOD OR PROCESS DISCLOSED IN THESE DRAWINGS. DRAWINGS MADE AVAILABLE FOR INFORMATION TO BIDDERS ARE NOT TO BE USED FOR OTHER PURPOSES, AND ARE TO BE RETURNED UPON REQUEST OF THE DRAWING CONTRACTOR.

**P** THIS DRAWING PRODUCED ON PRO-ENGINEER

FOR NOTES AND PARTS LIST SEE SHEET 1

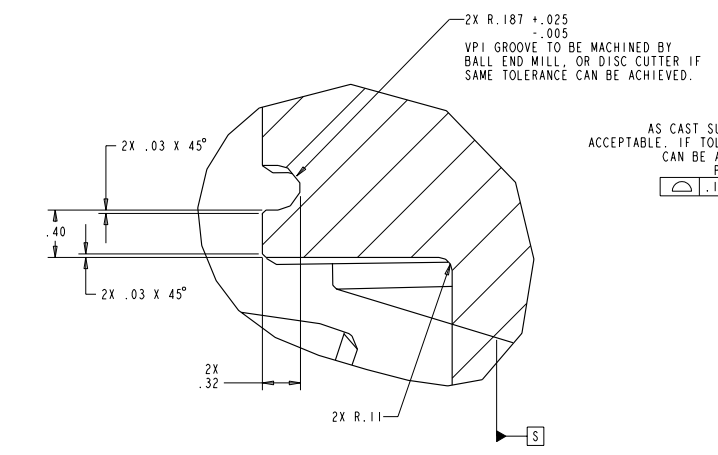

DETAIL B  
SCALE 2.000

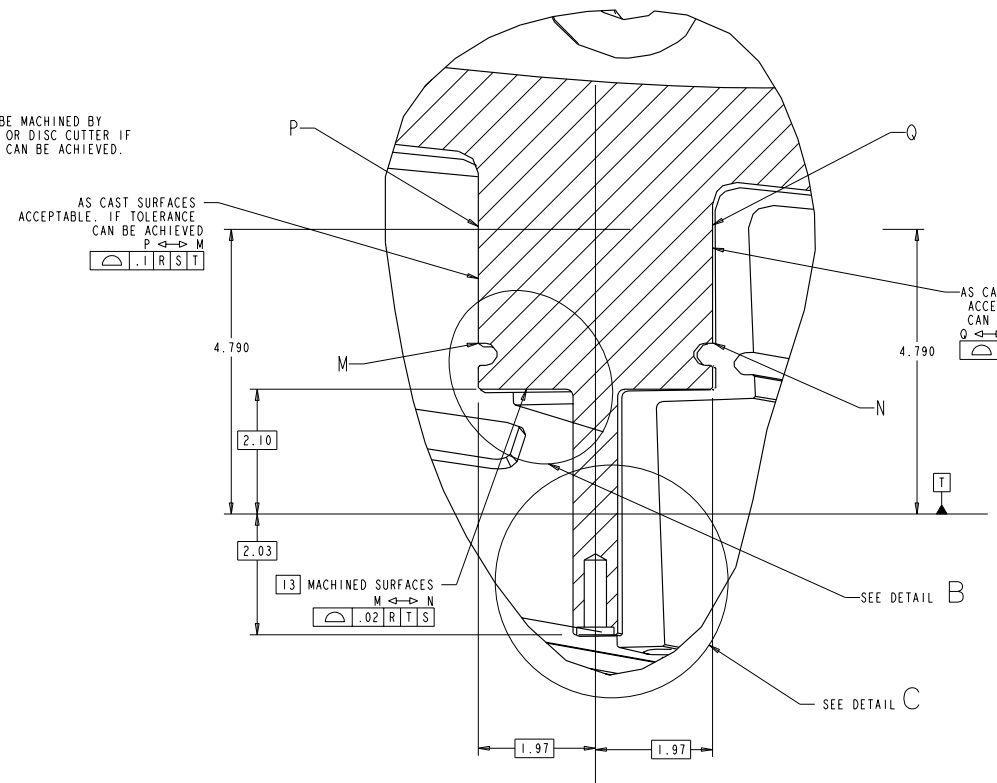

DETAIL A  
SCALE 1.00

TYPICAL FOR ALL POINTS ALONG WINDING CENTER

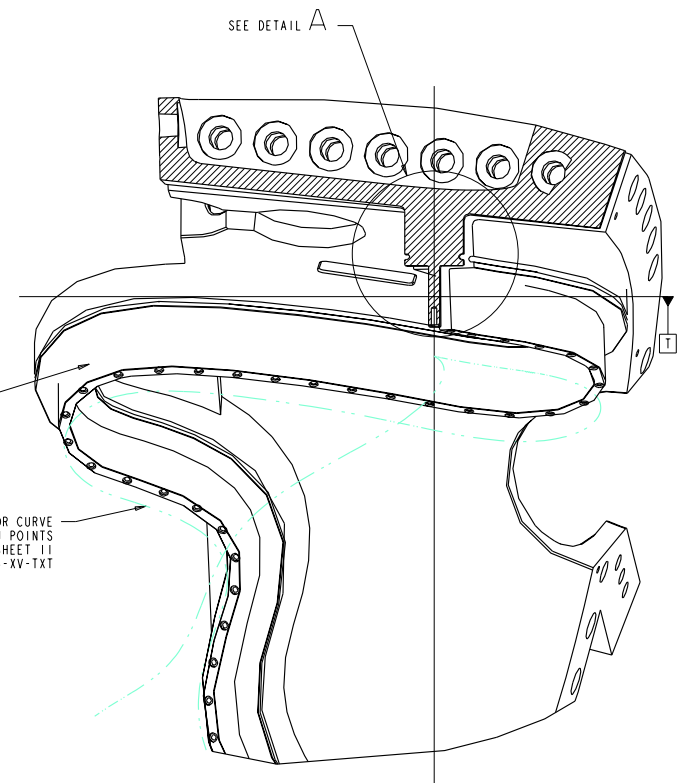

SECTION R-R  
SCALE 0.25

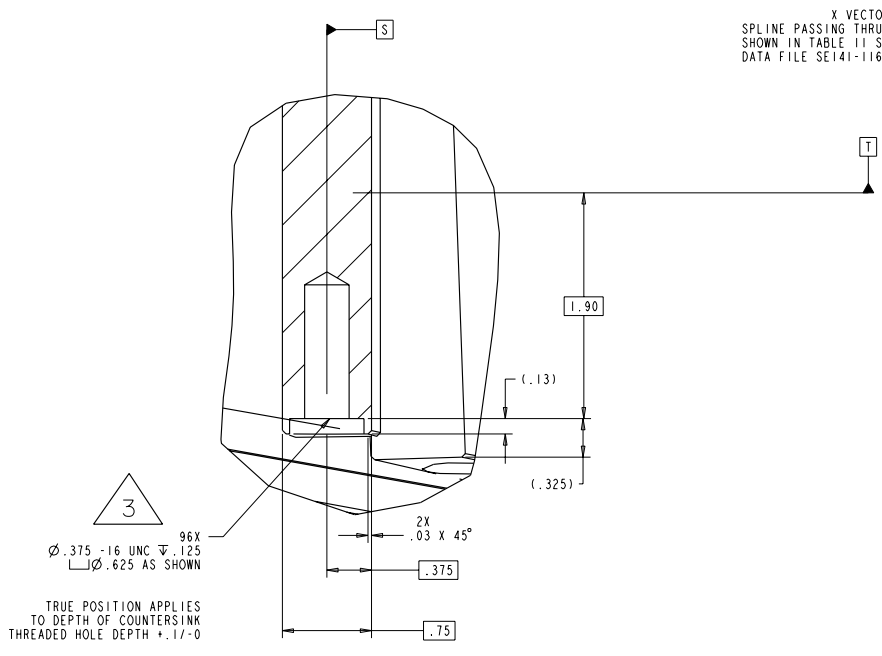
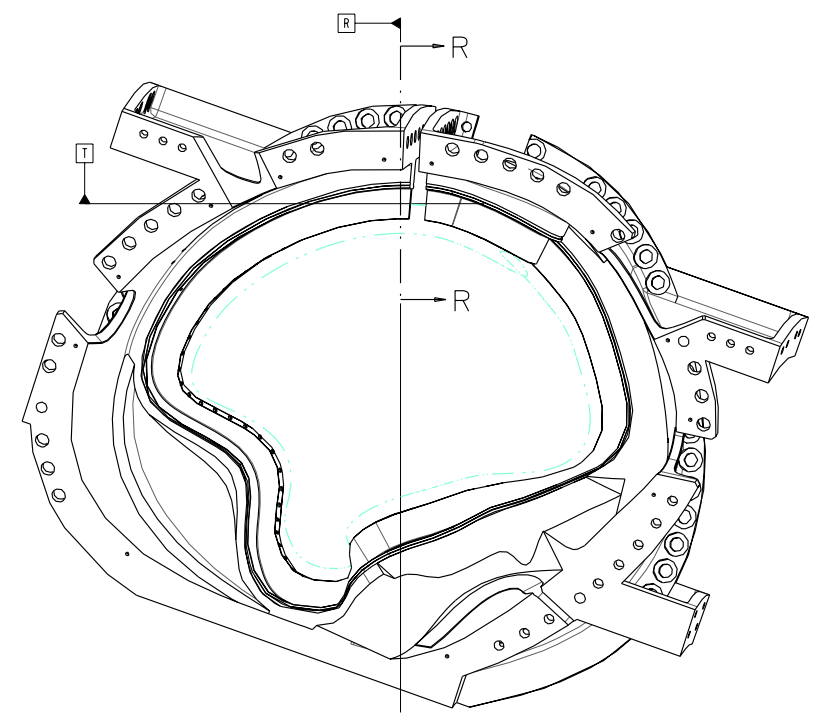

DETAIL C  
SCALE 2.00

DATUM R = PLANE NORMAL TO WINDING CENTER  
DATUM S = PLANE PASSING THRU WINDING CENTER AND X VECTOR AT DATUM R  
DATUM T = PLANE PASSING THRU WINDING CENTER ORTHOGONAL TO DATUM S

<b>UT-BATTELLE</b>		Oak Ridge National Laboratory managed for the DEPARTMENT OF ENERGY under U.S. GOVERNMENT contract DE-AC05-80OR21400 UT-BATTELLE, LLC, Oak Ridge, Tennessee	
NATIONAL COMPACT STELLARATOR EXPERIMENT			
PRODUCTION WINDING FORM TYPE-C			
VERSION NO.	PLANT	BLDG	FL
S	X-10	5700	3
RELEASE LEVEL	WIP	SE141-116	REV 3

FOR NOTES AND PARTS LIST SEE SHEET 1

8 7 6 5 4 3 2 1

H  
G  
F  
E  
D  
C  
B  
A

H  
G  
F  
E  
D  
C  
B  
A

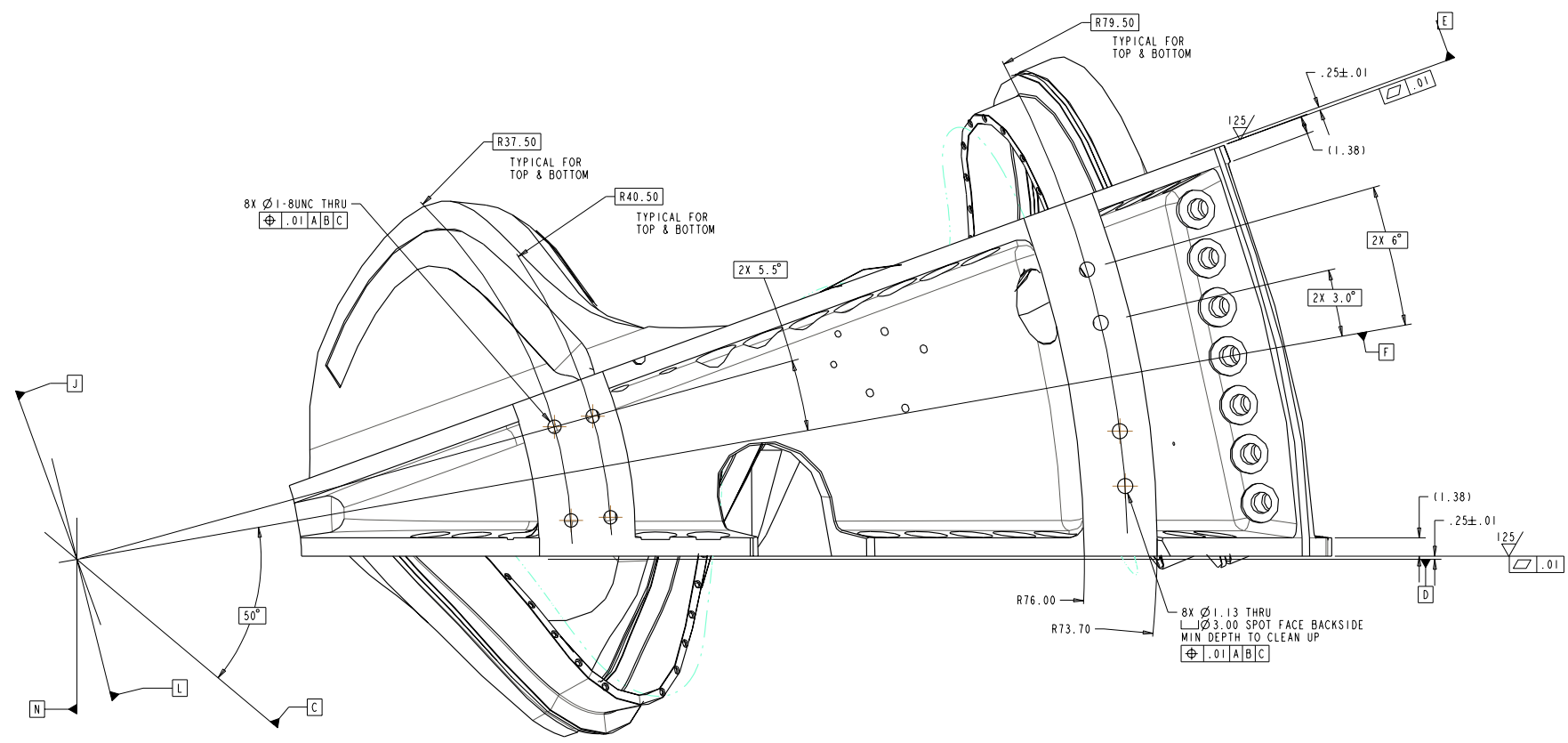

TOP VIEW  
SCALE 0.25

DATUMS A B & C ARE MACHINE SPECIFIC.  
ALL OTHER DATUMS LISTED ON THIS DRAWING  
ARE SPECIFIC TO THIS PART

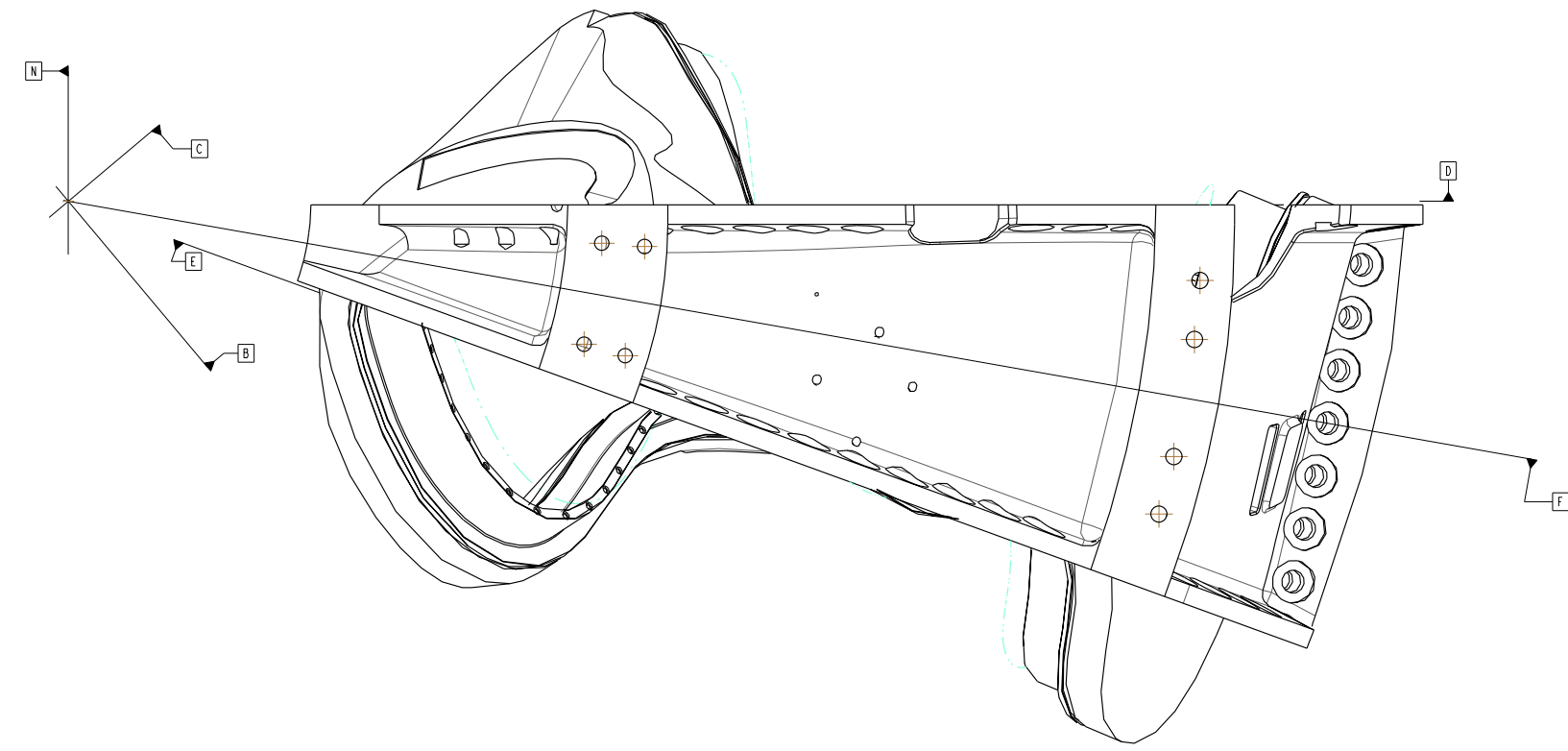

BOTTOM VIEW  
SCALE 0.25

8 7 6 5 4 3 2 1

Oak Ridge National Laboratory managed for the DEPARTMENT OF ENERGY under U.S. GOVERNMENT CONTRACT DE-AC05-80OR21400 UT-BATTELLE, LLC, Oak Ridge, Tennessee PROJECT NAME							
<b>UT-BATTELLE</b>							
NATIONAL COMPACT STELLARATOR EXPERIMENT							
PRODUCTION WINDING FORM TYPE-C							
VERSION NO.	PLANT	BLDG	FL	SHT	OF	TYPE	CLASS
6	X-10	5700	3	13	11	S	U
RELEASE LEVEL	SE141-116						REV
WIP							3

SE141-116

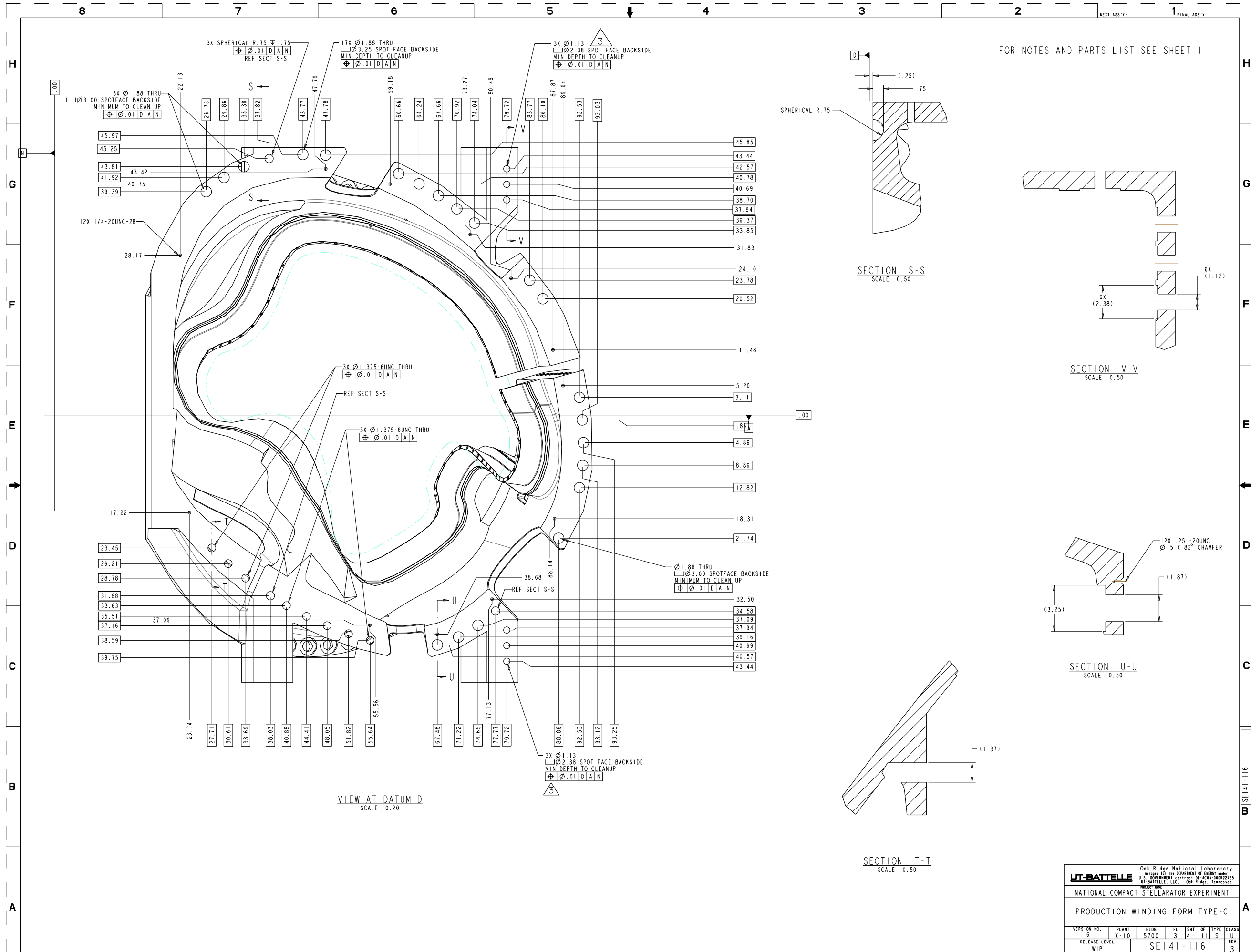

FOR NOTES AND PARTS LIST SEE SHEET 1

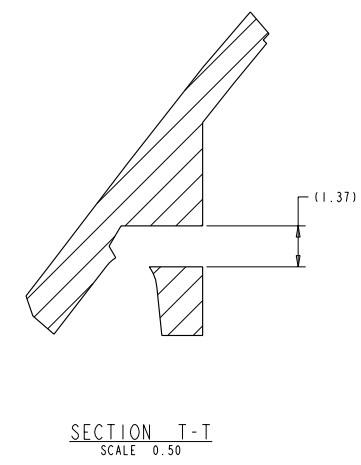
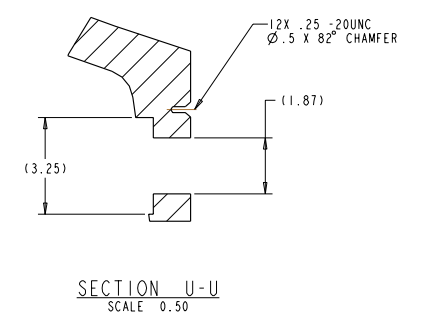
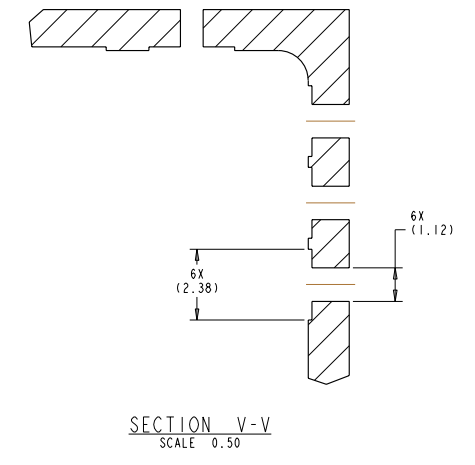
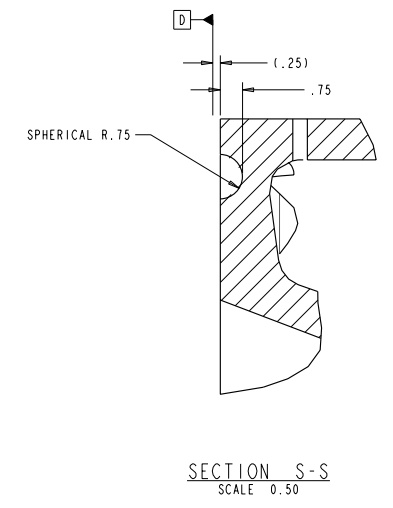

Oak Ridge National Laboratory <b>UT-BATTELLE</b> managed for the DEPARTMENT OF ENERGY under U.S. GOVERNMENT CONTRACT # AC05-84OR21400 UT-BATTELLE, LLC, Oak Ridge, Tennessee PROJECT NAME						
NATIONAL COMPACT STELLARATOR EXPERIMENT						
PRODUCTION WINDING FORM TYPE-C						
VERSION NO.	PLANT	BLDG	FL	SHT OF	TYPE	CLASS
6	X-10	5700	3	14	11	S
RELEASE LEVEL					U	REV
WIP					SE141-116	3

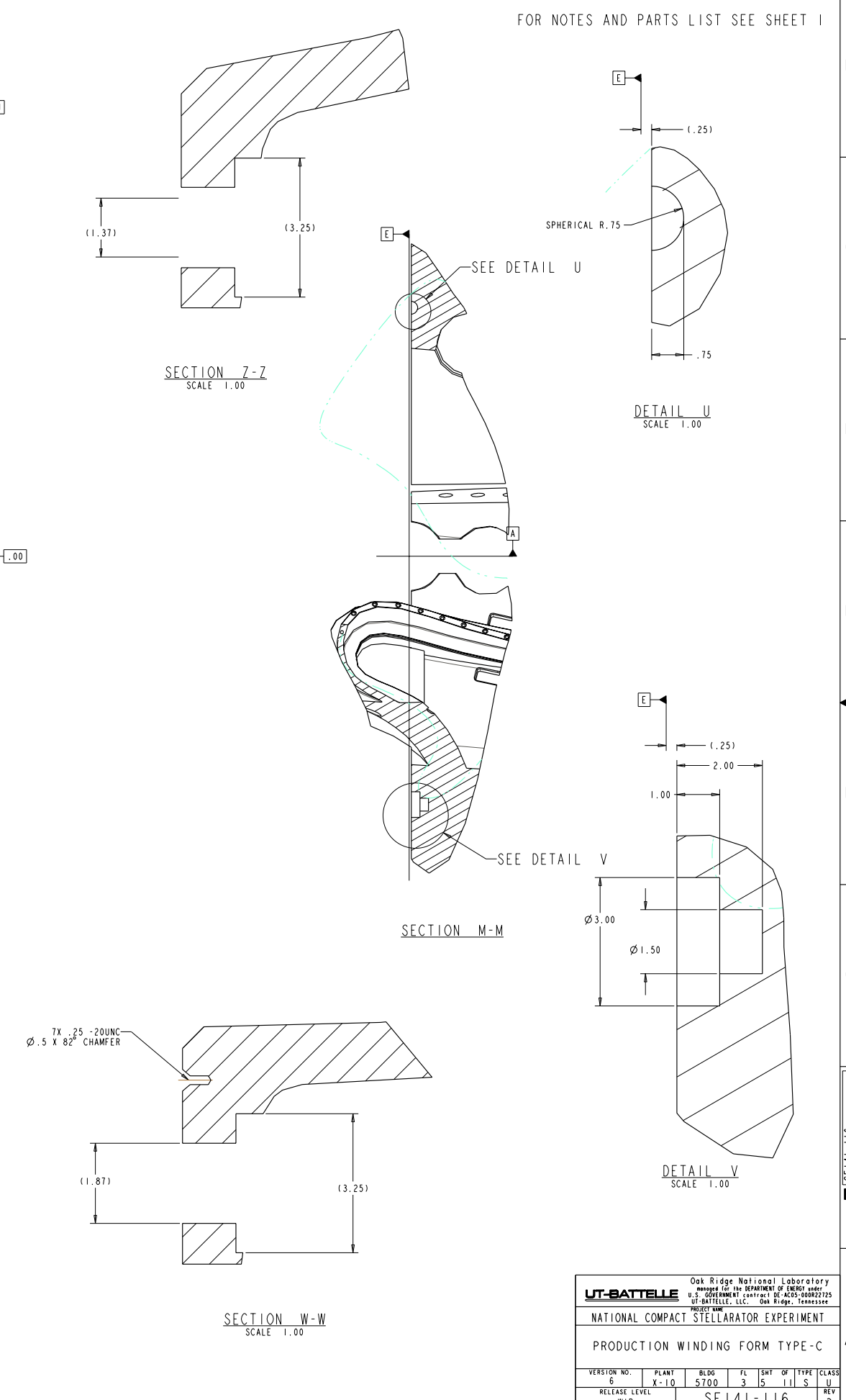
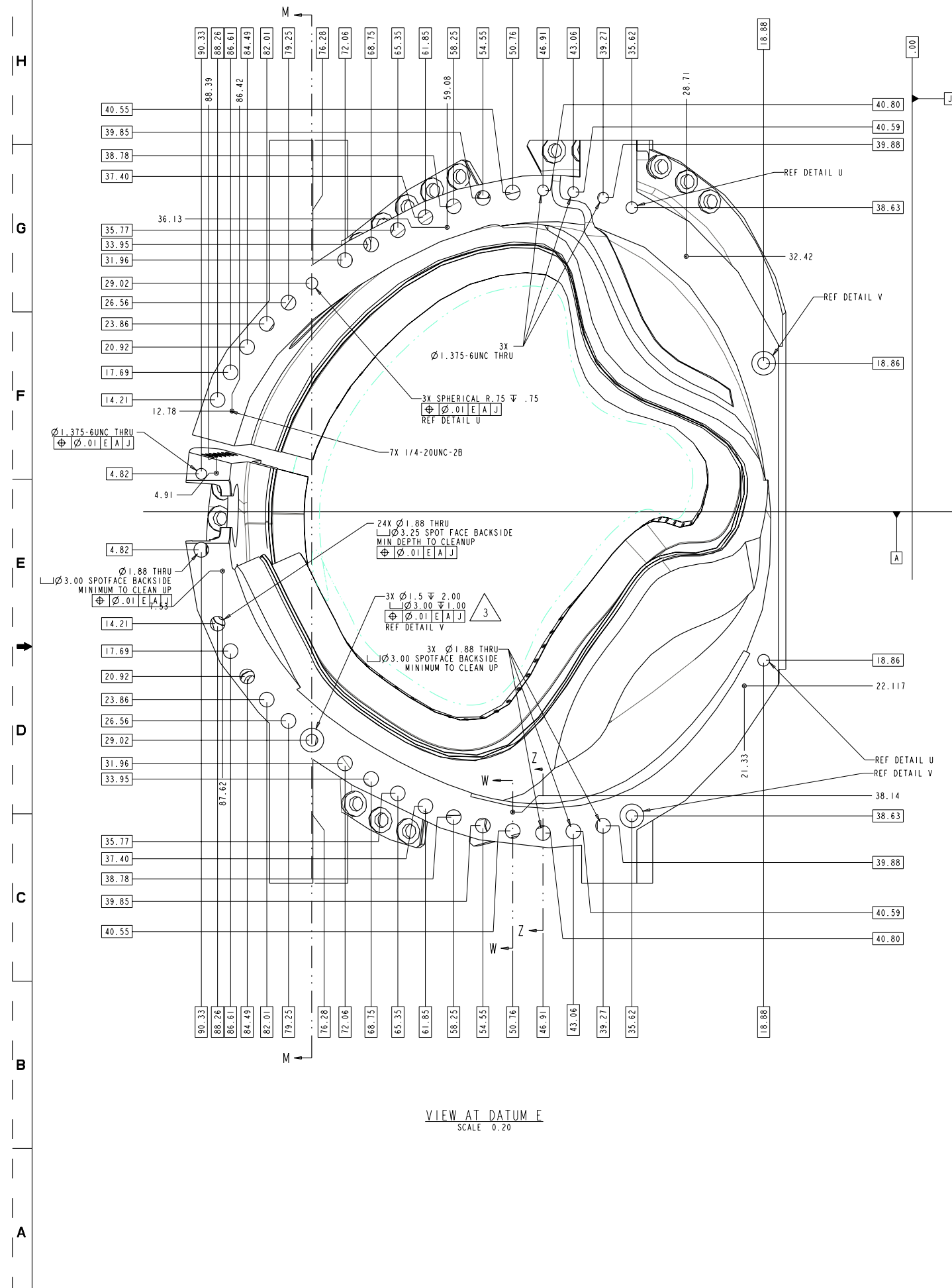

FOR NOTES AND PARTS LIST SEE SHEET I

Oak Ridge National Laboratory managed for the DEPARTMENT OF ENERGY under U.S. GOVERNMENT CONTRACT NO. AC05-84OR21400 UT-BATTELLE, LLC, Oak Ridge, Tennessee PROJECT NAME:						
<b>UT-BATTELLE</b>						
NATIONAL COMPACT STELLARATOR EXPERIMENT						
PRODUCTION WINDING FORM TYPE-C						
VERSION NO.	PLANT	BLDG	FL	SHT	OF TYPE	CLASS
6	X-10	5700	3	15	11	S
RELEASE LEVEL	SE 141-116					REV
WIP						3

H  
G  
F  
E  
D  
C  
B  
A

H  
G  
F  
E  
D  
C  
B  
A

SE 141-116

FOR NOTES AND PARTS LIST SEE SHEET 1

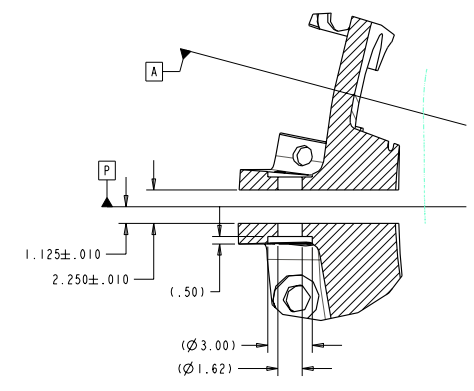
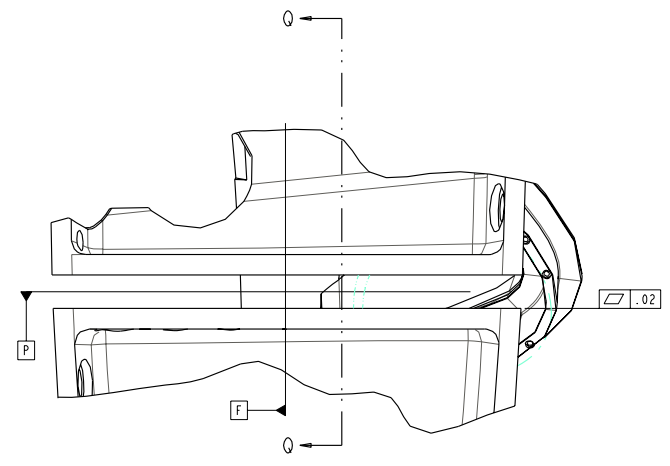
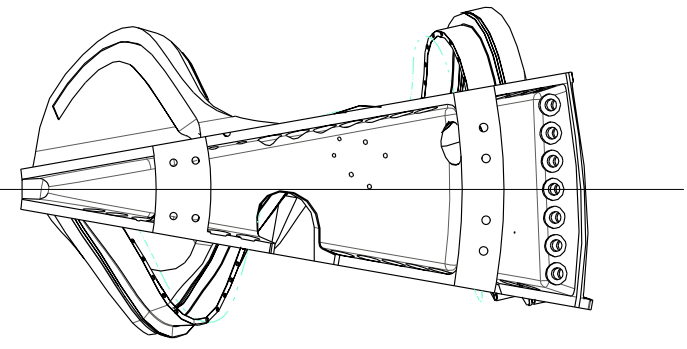

SECTION Q-Q

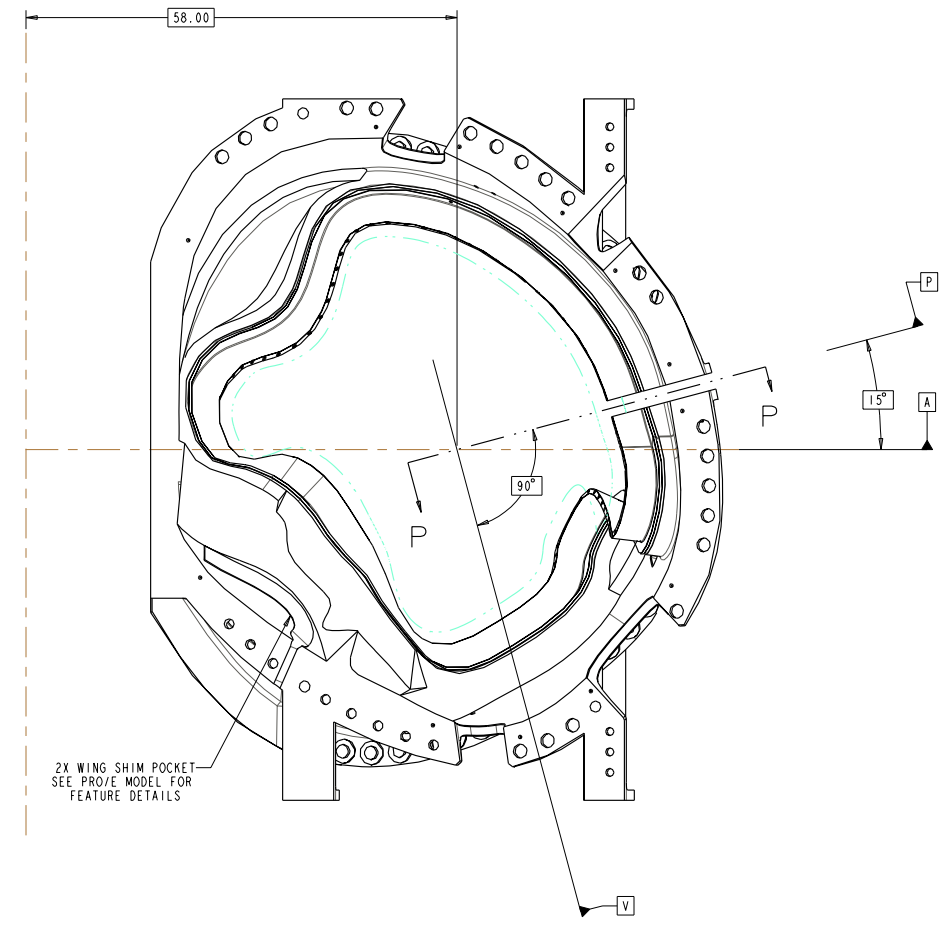

POLOIDAL BREAK DETAIL

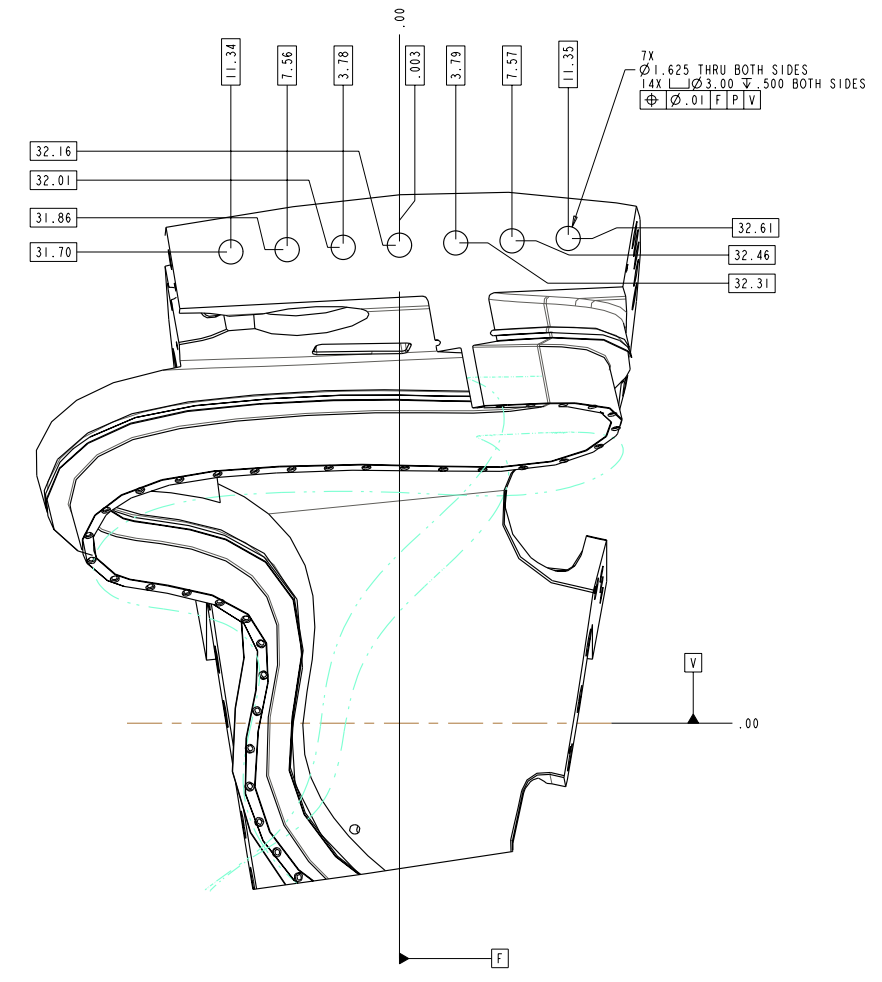

SECTION P-P  
SCALE 0.25

2X WING SHIM POCKET  
SEE PRO/E MODEL FOR  
FEATURE DETAILS

7X  
Ø 1.625 THRU BOTH SIDES  
14X Ø 3.00 V.500 BOTH SIDES  
Ø .01 F|P|V

<b>UT-BATTELLE</b>		Oak Ridge National Laboratory managed for the DEPARTMENT OF ENERGY under U.S. GOVERNMENT contract # AC05-84OR21400 UT-BATTELLE, LLC, Oak Ridge, Tennessee			
NATIONAL COMPACT STELLARATOR EXPERIMENT					
PRODUCTION WINDING FORM TYPE-C					
VERSION NO. S	PLANT X-10	BLDG 5700	FL 3	SHT OF TYPE 6 11	CLASS S U
RELEASE LEVEL WIP	SE141-116		REV 3		

FOR NOTES AND PARTS LIST SEE SHEET 1

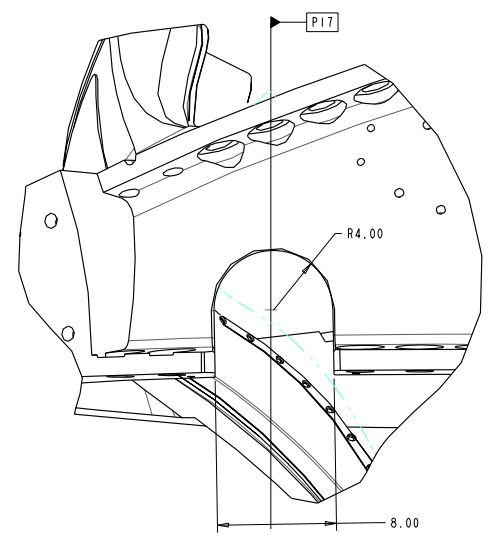
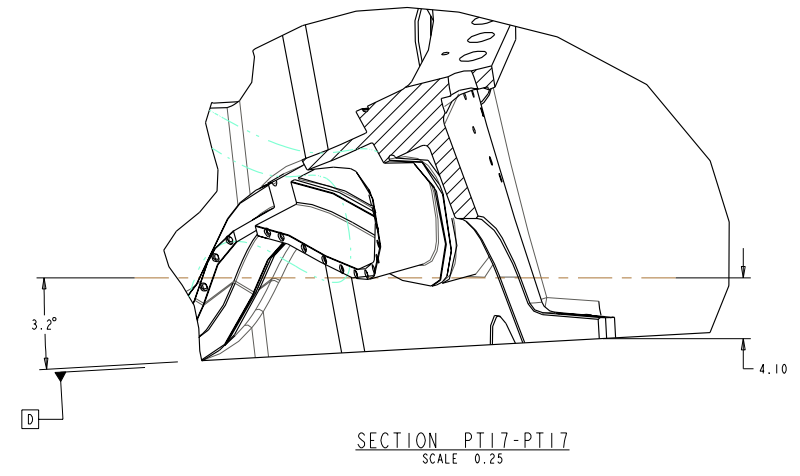
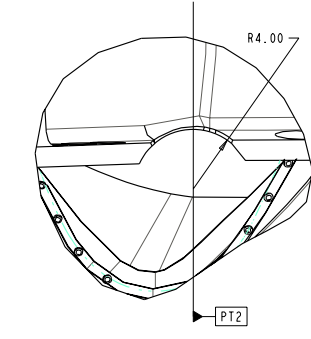
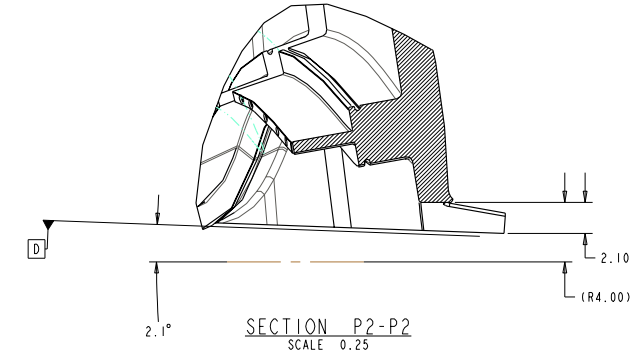
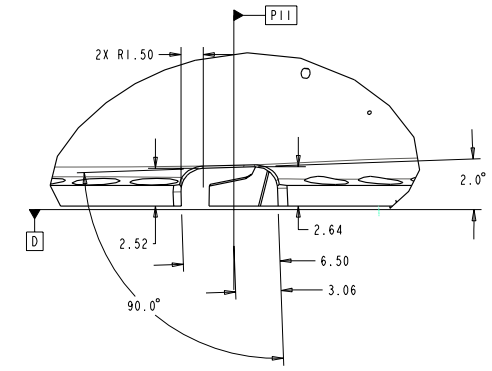
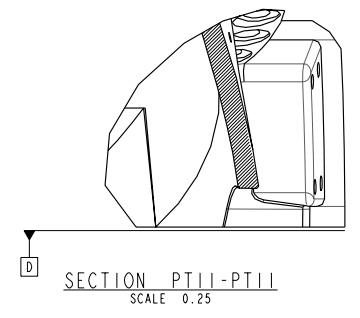
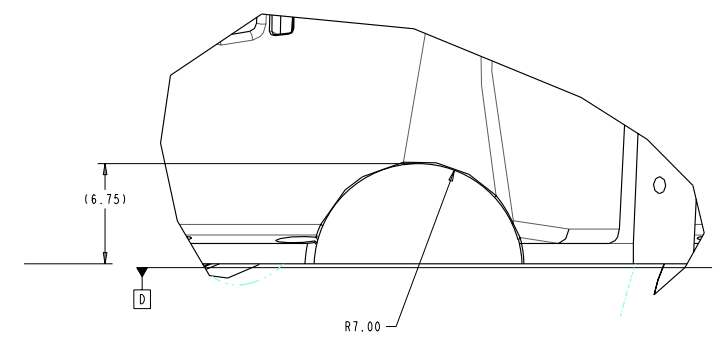
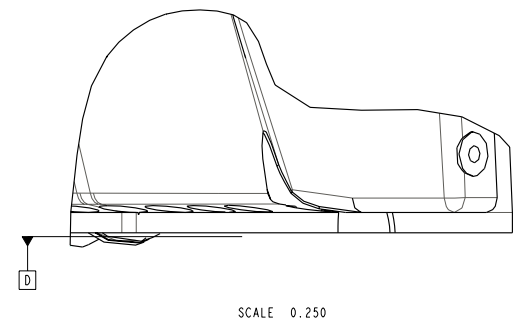
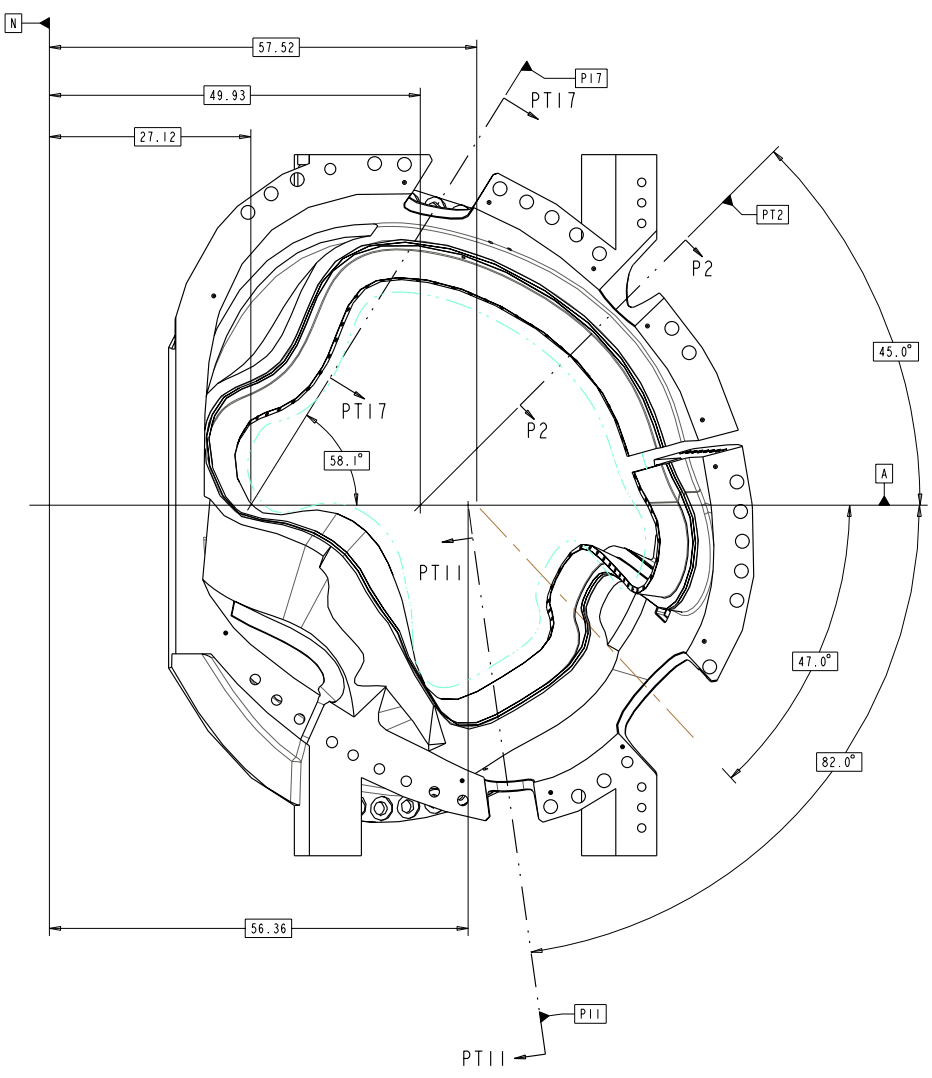

Oak Ridge National Laboratory managed for the DEPARTMENT OF ENERGY under U.S. GOVERNMENT CONTRACT NO. AC05-84OR21400 UT-BATTELLE, LLC, Oak Ridge, Tennessee PROJECT NAME						
<b>UT-BATTELLE</b>						
NATIONAL COMPACT STELLARATOR EXPERIMENT						
PRODUCTION WINDING FORM TYPE-C						
VERSION NO.	PLANT	BLDG	FL	SHT OF TYPE	CLASS	
6	X-10	5700	3	17	U	S
RELEASE LEVEL	SE141-116					REV
WIP						3

SE141-116

FOR NOTES AND PARTS LIST SEE SHEET 1

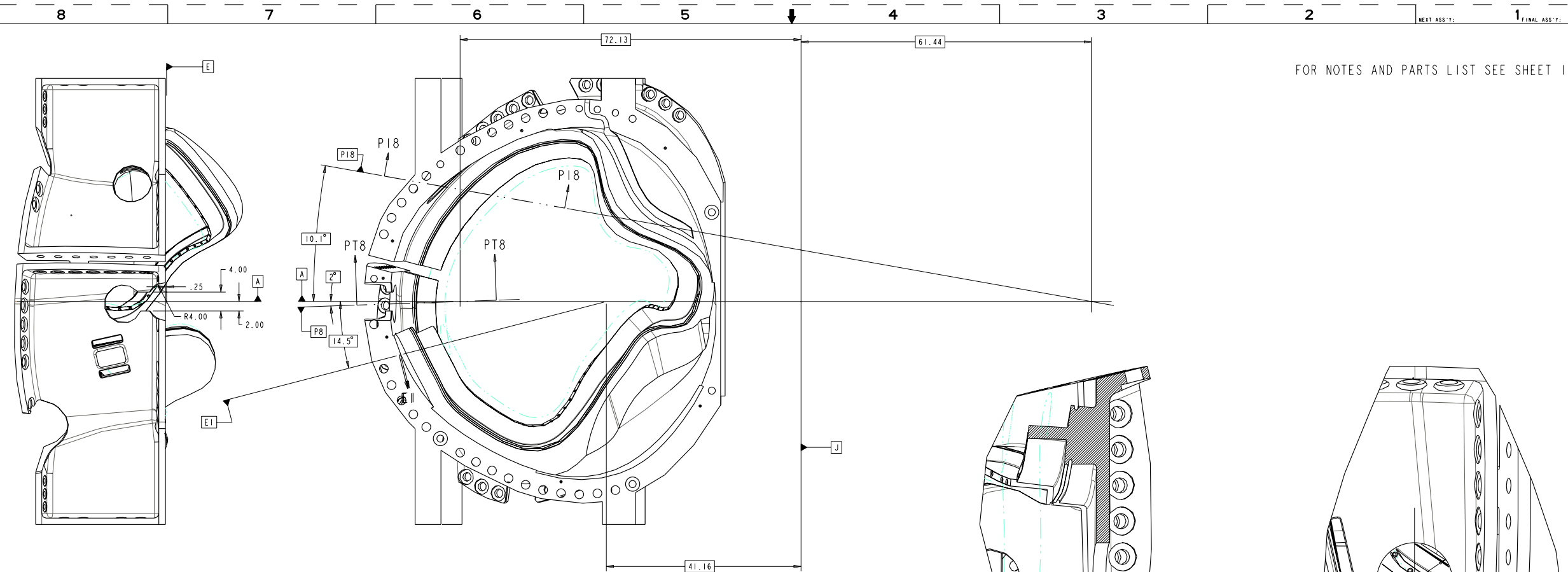

VIEW AT DATUM E  
SCALE 0.13

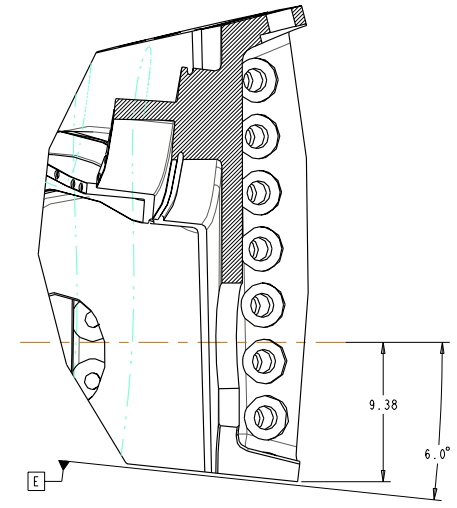

SECTION PT8-PT8  
SCALE 0.25

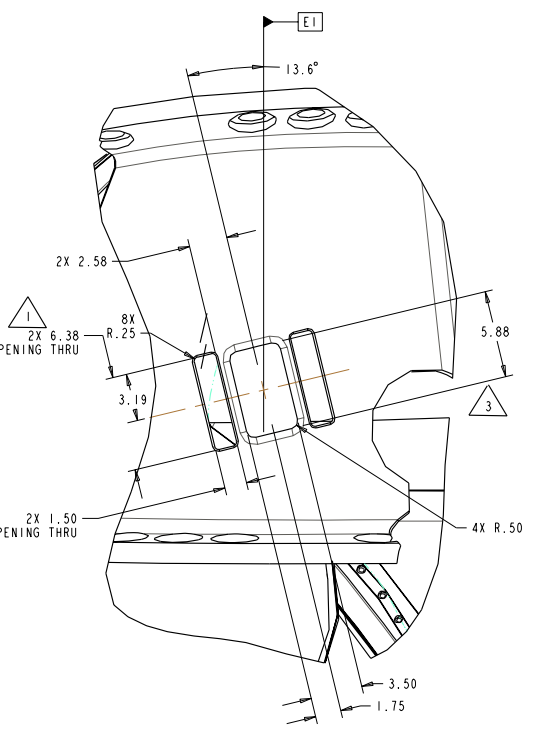
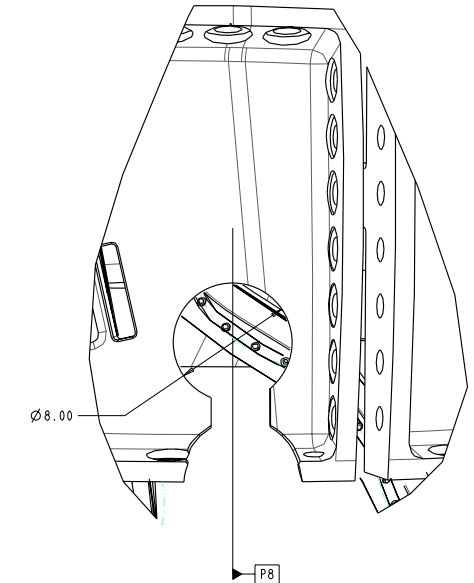

LEAD BLOCK DETAIL

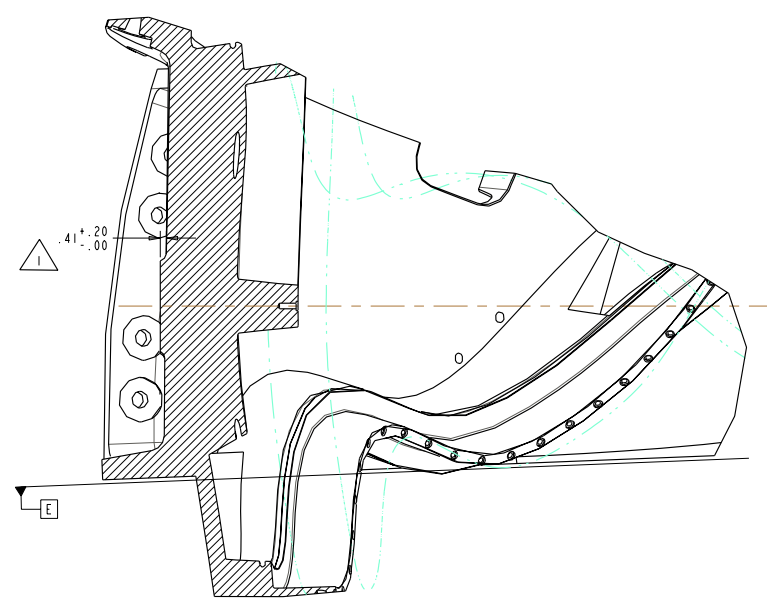

SECTION E1-E1  
SCALE 0.25

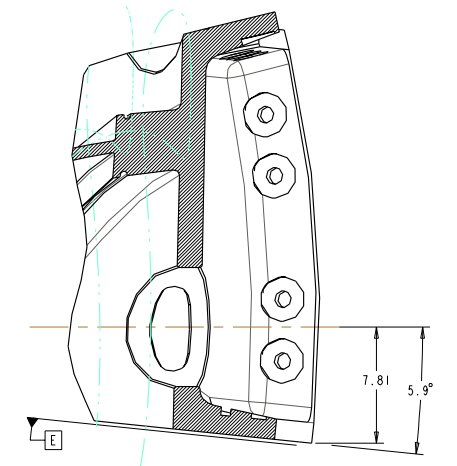

SECTION P18-P18  
SCALE 0.25

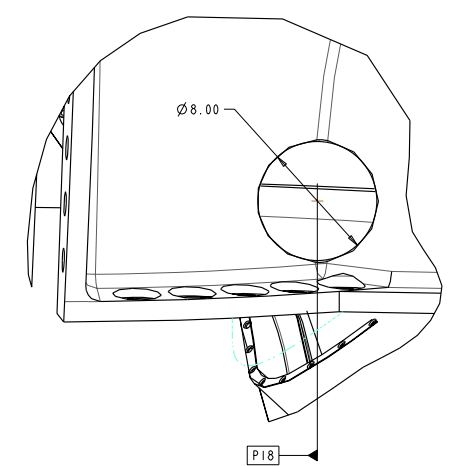

Oak Ridge National Laboratory managed for the DEPARTMENT OF ENERGY under U.S. GOVERNMENT contract DE-AC05-80OR21400 UT-BATTELLE, LLC, Oak Ridge, Tennessee PROJECT NAME:								
<b>UT-BATTELLE</b>								
NATIONAL COMPACT STELLARATOR EXPERIMENT								
PRODUCTION WINDING FORM TYPE-C								
VERSION NO.	PLANT	BLDG	FL	SHT	OF	TYPE	CLASS	
6	X-10	5700	3	18	11	S	U	
RELEASE LEVEL	SE141-116						REV	3
WIP								

SE141-116



FOR NOTES AND PARTS LIST SEE SHEET 1

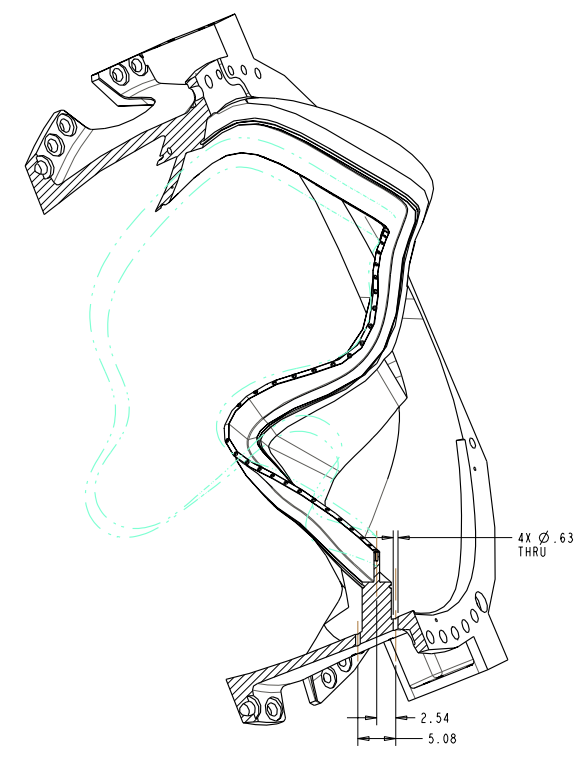

SECTION X-X  
USE PRO/E MODEL GEOMETRY TO DETERMINE SECTION ORIENTATION

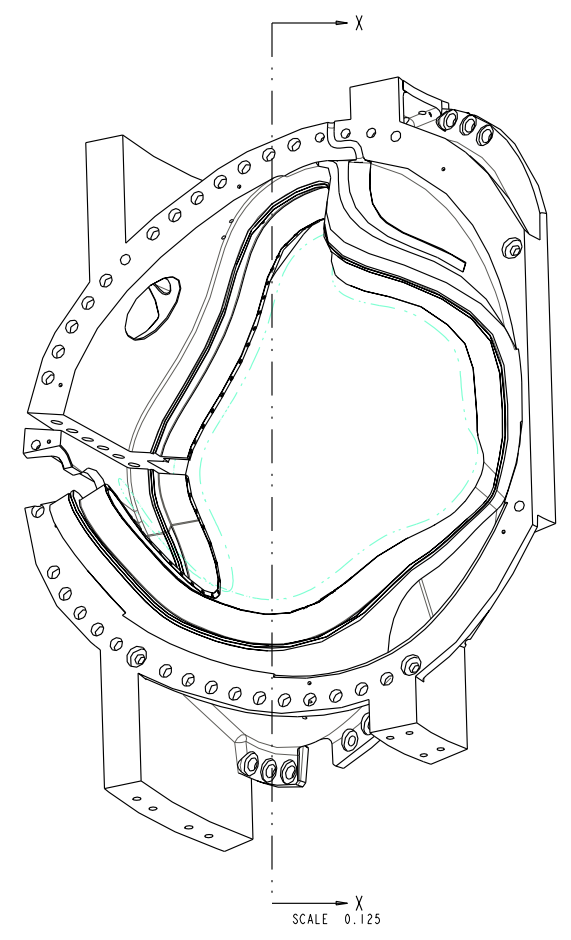

SECTION Y-Y  
SCALE 0.125

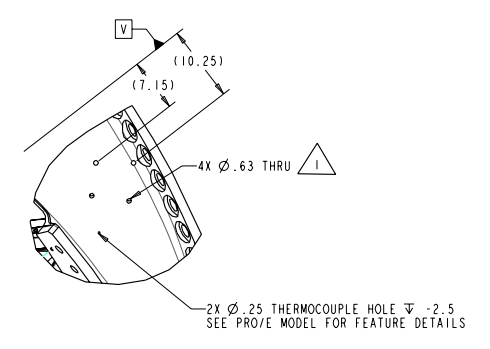
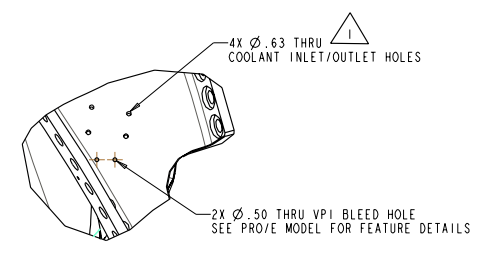

COOLING INLET / OUTLET HOLES  
TYPICAL 2 PLACES

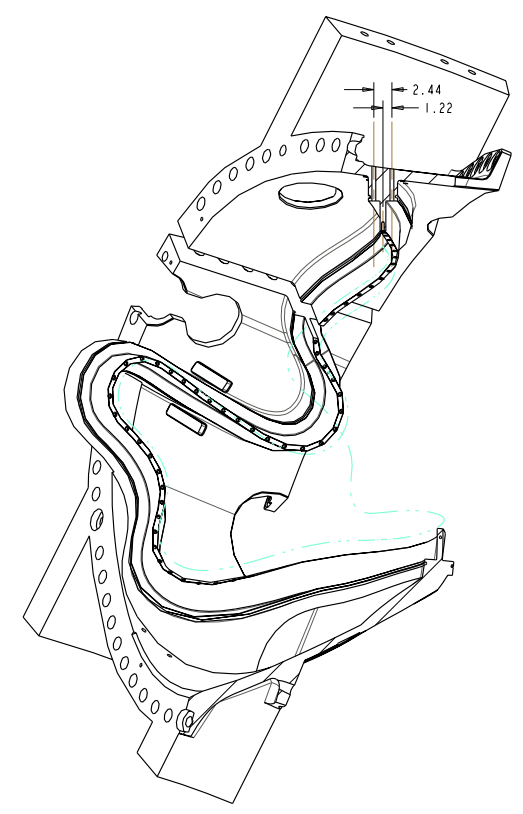

USE PRO/E MODEL GEOMETRY TO DETERMINE SECTION ORIENTATION

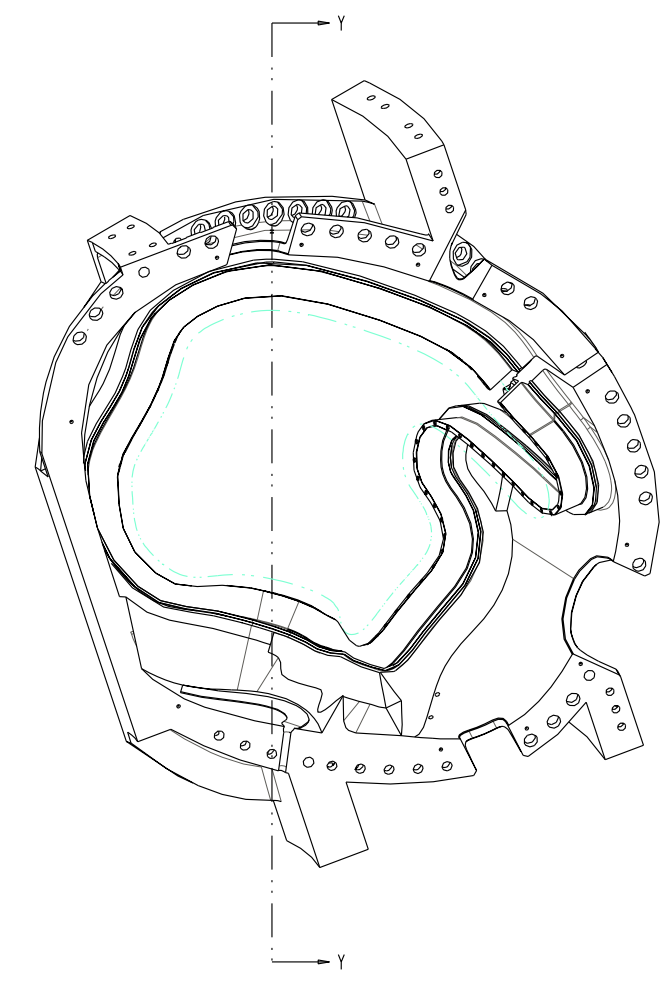

<b>UT-BATTELLE</b>		Oak Ridge National Laboratory managed for the DEPARTMENT OF ENERGY under U.S. GOVERNMENT contract # AC05-84OR21400 UT-BATTELLE, LLC, Oak Ridge, Tennessee					
PROJECT NAME							
NATIONAL COMPACT STELLARATOR EXPERIMENT							
PRODUCTION WINDING FORM TYPE-C							
VERSION NO.	PLANT	BLDG	FL	SHT	OF TYPE	CLASS	
6	X-10	5700	3	19	11	S	U
RELEASE LEVEL	REV						
WIP	SE141-116						3

H  
G  
F  
E  
D  
C  
B  
A

H  
G  
F  
E  
D  
C  
B  
A

8

7

6

5

↓

4

3

2

NEXT ASS'Y:

1 FINAL ASS'Y:

FOR NOTES AND PARTS LIST SEE SHEET I

H

G

F

E

D

C

B

A

H

G

F

E

D

C

B

A

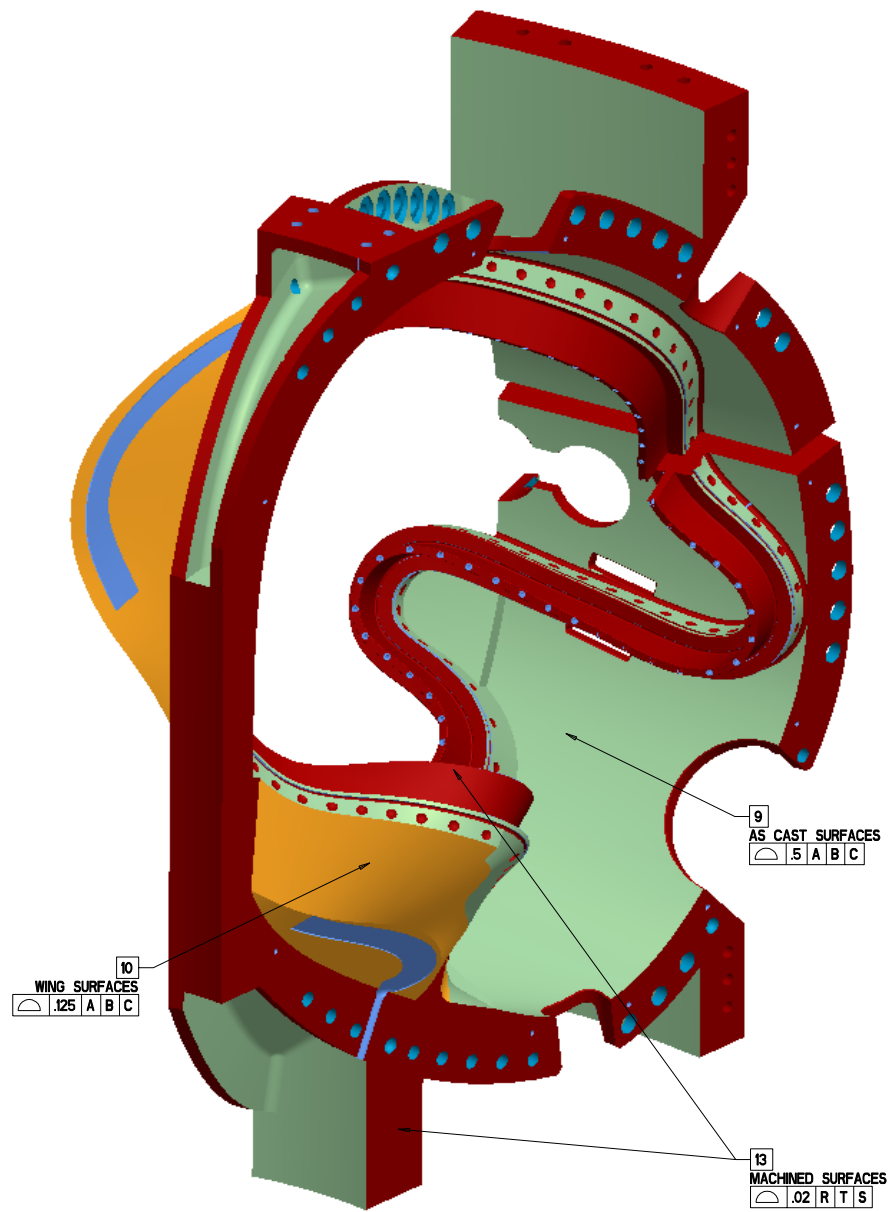

ISOMETRIC VIEW  
NOT TO SCALE

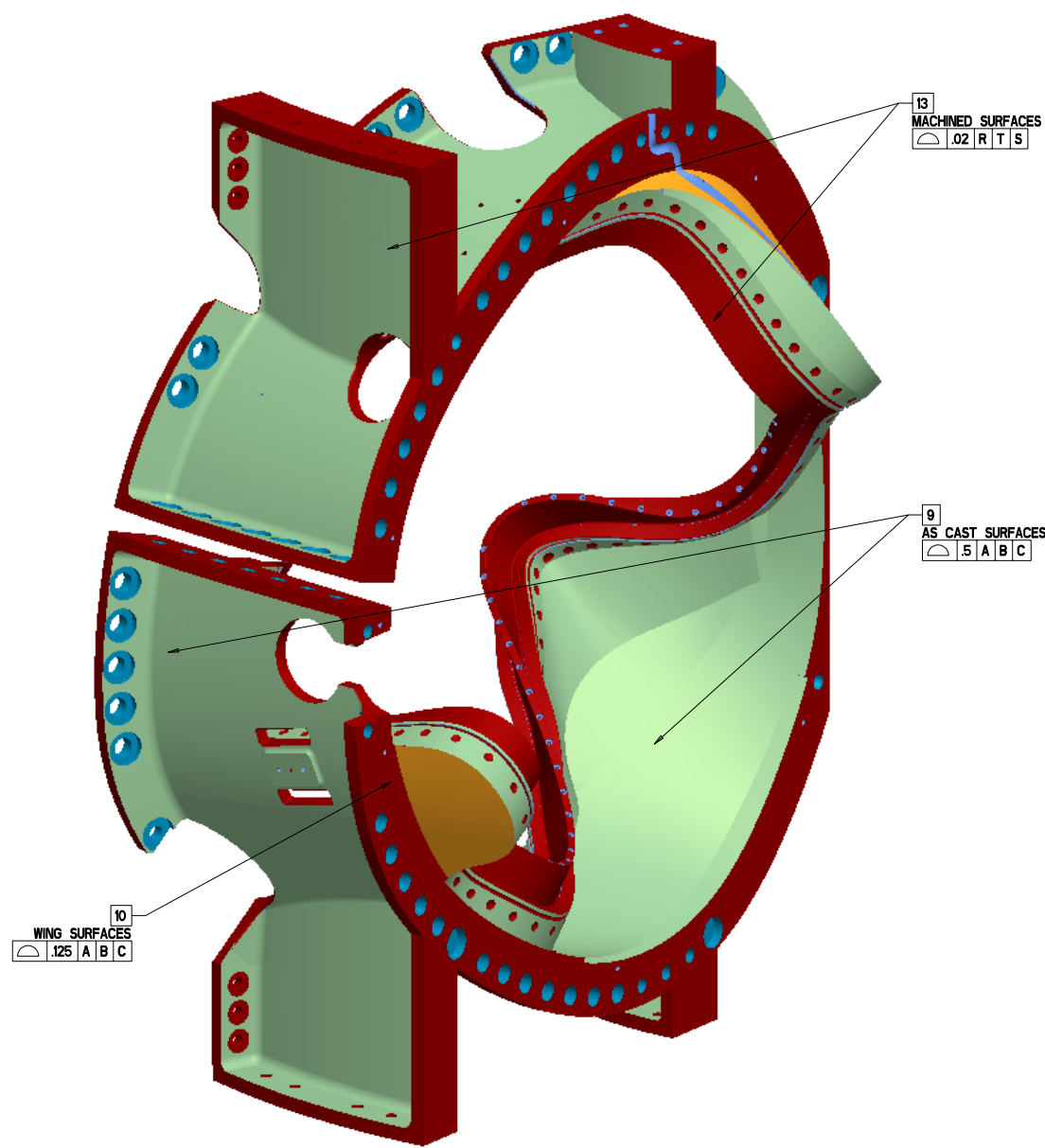

ISOMETRIC VIEW  
NOT TO SCALE

<b>UT-BATTELLE</b>		Oak Ridge National Laboratory managed for the DEPARTMENT OF ENERGY under U.S. GOVERNMENT contract DE-AC05-80OR21400 UT-BATTELLE, LLC, Oak Ridge, Tennessee					
NATIONAL COMPACT STELLARATOR EXPERIMENT							
PRODUCTION WINDING FORM TYPE-C							
VERSION NO.	PLANT	BLDG	FL	SHT	OF TYPE	CLASS	
S	X-10	5700	3	110	11	S	U
RELEASE LEVEL	SE141-116					REV	3
WIP							

8

7

6

5

↑

4

3

2

1

TABLE I WINDING CENTER SPLINE  
(FILE SEI4I-II6-WC.TXT)

#	X	Y	Z
1	60.145	56.794	0.000
2	58.276	57.786	1.503
3	56.596	58.526	3.327
4	55.416	58.692	5.615
5	54.871	58.162	8.086
6	54.722	57.153	10.470
7	54.637	55.902	12.743
8	54.360	54.558	14.945
9	53.748	53.221	17.082
10	52.767	51.957	19.123
11	51.421	50.828	21.031
12	49.744	49.886	22.771
13	47.797	49.153	24.321
14	45.661	48.609	25.690
15	43.406	48.198	26.909
16	41.088	47.830	28.018
17	38.744	47.399	29.046
18	36.404	46.795	29.991
19	34.109	45.921	30.830
20	31.918	44.720	31.524
21	29.878	43.203	32.041
22	27.960	41.481	32.335
23	26.012	39.770	32.290
24	23.995	38.421	31.681
25	21.750	37.007	30.385
26	19.849	37.887	28.631
27	18.194	38.324	26.681
28	16.673	38.852	24.645
29	15.192	39.316	22.564
30	13.689	39.615	20.469
31	12.134	39.566	18.396
32	10.613	38.827	16.444
33	9.437	37.164	14.867
34	8.851	34.871	13.829
35	8.791	32.366	13.165
36	9.101	29.862	12.562
37	9.681	27.475	11.732
38	10.467	25.270	10.612
39	11.320	23.189	9.316
40	12.144	21.365	7.674
41	13.054	20.132	5.590
42	14.179	19.494	3.345
43	15.620	19.190	1.211
44	17.452	18.936	-0.604
45	19.685	18.670	-1.883
46	22.201	18.487	-2.462
47	24.788	18.307	-2.511
48	27.365	18.030	-2.361
49	29.931	17.652	-2.270
50	32.494	17.273	-2.415
51	35.028	17.114	-2.930
52	37.378	17.455	-3.943
53	38.999	18.562	-5.590
54	39.391	20.227	-7.511
55	38.948	22.059	-9.290
56	38.254	23.967	-10.907
57	37.524	25.943	-12.425
58	36.701	27.920	-13.892
59	35.763	29.920	-15.391
60	34.793	31.625	-16.985
61	33.903	33.362	-18.696
62	33.146	35.089	-20.480
63	32.490	36.854	-22.267
64	31.865	38.690	-23.993
65	31.269	40.647	-25.590
66	30.783	42.808	-26.939
67	30.499	45.207	-27.875
68	30.477	47.768	-28.246
69	30.808	50.319	-27.976
70	31.626	52.619	-27.122
71	32.955	54.471	-25.896
72	34.623	55.924	-24.542
73	36.363	57.257	-23.152
74	37.796	58.796	-21.641
75	38.357	60.653	-19.947
76	37.834	62.568	-18.298
77	36.556	64.343	-16.912
78	34.902	65.986	-15.774
79	33.118	67.574	-14.756
80	31.730	69.226	-13.352
81	31.467	70.665	-11.246
82	32.350	71.447	-8.964
83	34.161	71.434	-7.148
84	36.508	70.729	-6.383
85	38.865	69.675	-6.573
86	41.103	68.510	-7.182
87	43.261	67.281	-7.937
88	45.389	65.991	-8.677
89	47.500	64.629	-9.329
90	49.589	63.190	-9.909
91	51.624	61.690	-10.474
92	53.637	60.150	-11.040
93	55.657	58.597	-11.534
94	57.737	57.067	-11.783
95	59.894	55.659	-11.529
96	61.987	54.568	-10.493
97	63.512	54.094	-8.487
98	63.981	54.255	-5.966
99	63.347	54.877	-3.547
100	61.939	55.773	-1.571
101	60.145	56.794	0.000

TABLE II X-VECTOR SPLINE  
(FILE SEI4I-II6-XV.TXT)

#	X	Y	Z
1	58.052	53.430	0.000
2	56.230	54.406	1.241
3	54.571	55.150	2.814
4	53.390	55.329	4.888
5	52.667	54.797	7.168
6	52.749	53.802	9.360
7	52.644	52.605	11.450
8	52.303	51.347	13.477
9	51.620	50.117	15.434
10	50.582	48.979	17.286
11	49.208	47.988	19.000
12	47.546	47.183	20.548
13	45.665	46.566	21.923
14	43.638	46.104	23.144
15	41.522	45.737	24.243
16	39.362	45.377	25.253
17	37.186	44.926	26.189
18	35.025	44.274	27.037
19	32.934	43.319	27.758
20	30.975	42.026	28.303
21	29.136	40.501	28.619
22	27.278	38.970	28.596
23	25.247	37.504	27.936
24	23.332	37.806	26.507
25	21.742	38.267	24.757
26	20.322	38.864	22.902
27	18.955	39.416	20.993
28	17.580	39.835	19.056
29	16.161	40.022	17.117
30	14.706	39.785	15.214
31	13.357	38.819	13.486
32	12.429	37.021	12.211
33	12.113	34.747	11.511
34	12.293	32.373	11.144
35	12.782	30.060	10.681
36	13.440	27.941	9.749
37	14.118	26.018	8.463
38	14.685	24.325	6.854
39	15.233	23.393	4.718
40	16.258	23.052	2.571
41	17.825	22.789	0.764
42	19.822	22.415	-0.514
43	22.144	22.026	-0.973
44	24.518	21.651	-0.806
45	26.854	21.205	-0.407
46	29.172	20.671	-0.005
47	31.497	20.091	0.261
48	33.850	19.570	0.289
49	36.219	19.295	-0.034
50	38.478	19.477	-0.825
51	40.280	20.280	-2.176
52	41.259	21.626	-3.899
53	41.357	23.244	-5.670
54	40.743	24.958	-7.238
55	39.677	26.699	-8.519
56	38.487	28.468	-9.648
57	37.290	30.238	-10.766
58	36.171	31.978	-12.005
59	35.202	33.659	-13.436
60	34.128	35.192	-14.956
61	33.015	36.626	-16.545
62	31.934	38.039	-18.173
63	30.919	39.505	-19.797
64	30.020	41.095	-21.370
65	29.386	42.917	-22.812
66	29.008	45.005	-23.947
67	28.900	47.333	-24.530
68	29.158	49.714	-24.381
69	29.937	51.836	-23.580
70	31.222	53.508	-22.423
71	32.804	54.817	-21.162
72	34.456	56.011	-19.872
73	35.820	57.395	-18.459
74	36.077	59.117	-16.846
75	35.181	60.815	-15.406
76	33.770	62.378	-14.236
77	32.154	63.865	-13.239
78	30.624	65.372	-12.150
79	29.829	66.871	-10.476
80	30.132	67.939	-8.366
81	31.415	68.301	-6.387
82	33.393	67.975	-5.091
83	35.622	67.171	-4.744
84	37.773	66.151	-5.106
85	39.804	65.051	-5.797
86	41.755	63.898	-6.622
87	43.673	62.689	-7.444
88	45.576	61.412	-8.196
89	47.455	60.064	-8.880
90	49.301	58.659	-9.544
91	51.121	57.220	-10.201
92	52.949	55.764	-10.798
93	54.831	54.315	-11.210
94	56.801	52.930	-11.253
95	58.812	51.740	-10.740
96	60.658	50.858	-9.482
97	61.888	50.555	-7.459
98	62.103	50.818	-5.098
99	61.294	51.503	-2.951
100	59.824	52.420	-1.285
101	58.052	53.430	0.000



ALL POINT LOCATIONS ARE BASIC  
FOR NOTES AND PARTS LIST SEE SHEET I

Oak Ridge National Laboratory <b>UT-BATTELLE</b> managed for the DEPARTMENT OF ENERGY under U.S. GOVERNMENT CONTRACT DE-AC05-80OR21400 UT-BATTELLE, LLC, Oak Ridge, Tennessee							
NATIONAL COMPACT STELLARATOR EXPERIMENT							
PRODUCTION WINDING FORM TYPE-C							
VERSION NO.	PLANT	BLDG	FL	SHT	OF	TYPE	CLASS
6	X-10	5700	3	11	11	S	U
RELEASE LEVEL		SEI4I-116		REV		3	
WIP							