

NO.	REVISION	BY	CH	SUP	APPROVED	DATE

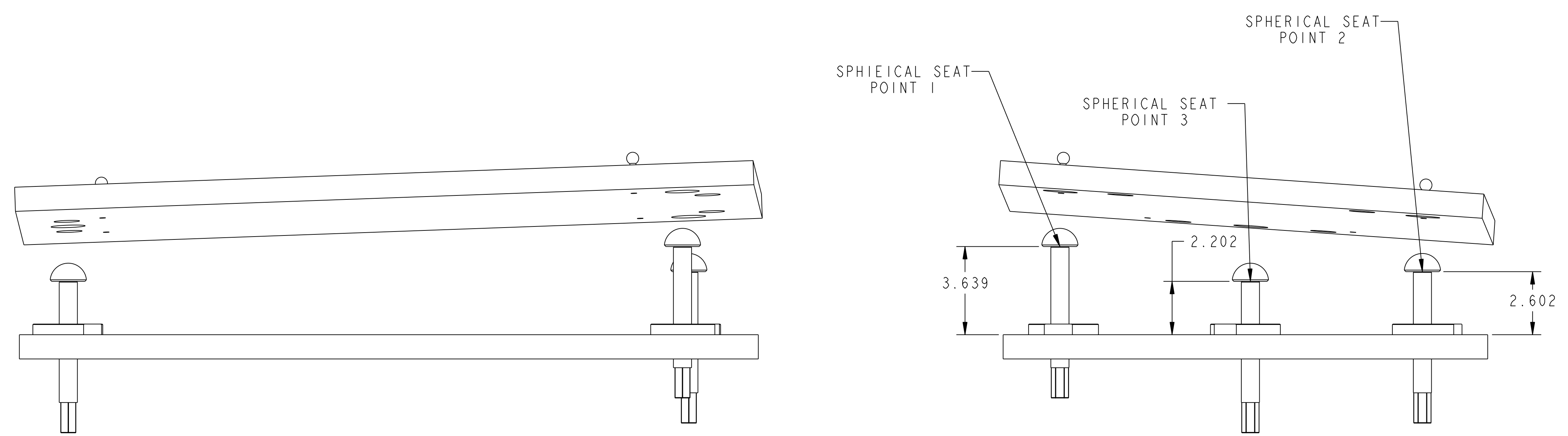

EXPLODED VIEWS

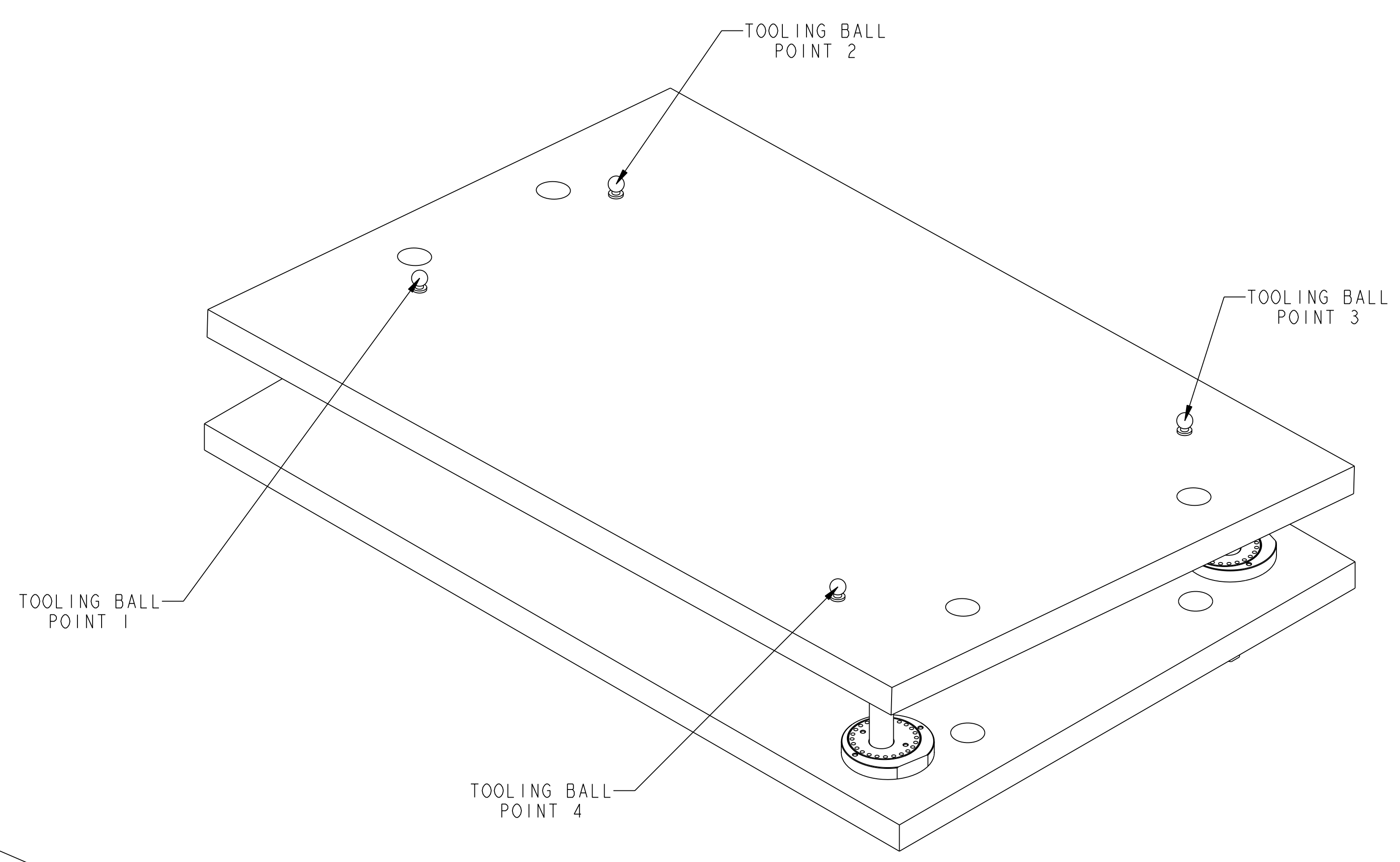

REFERENCE ISOMETRIC VIEW

SCALE 0.375

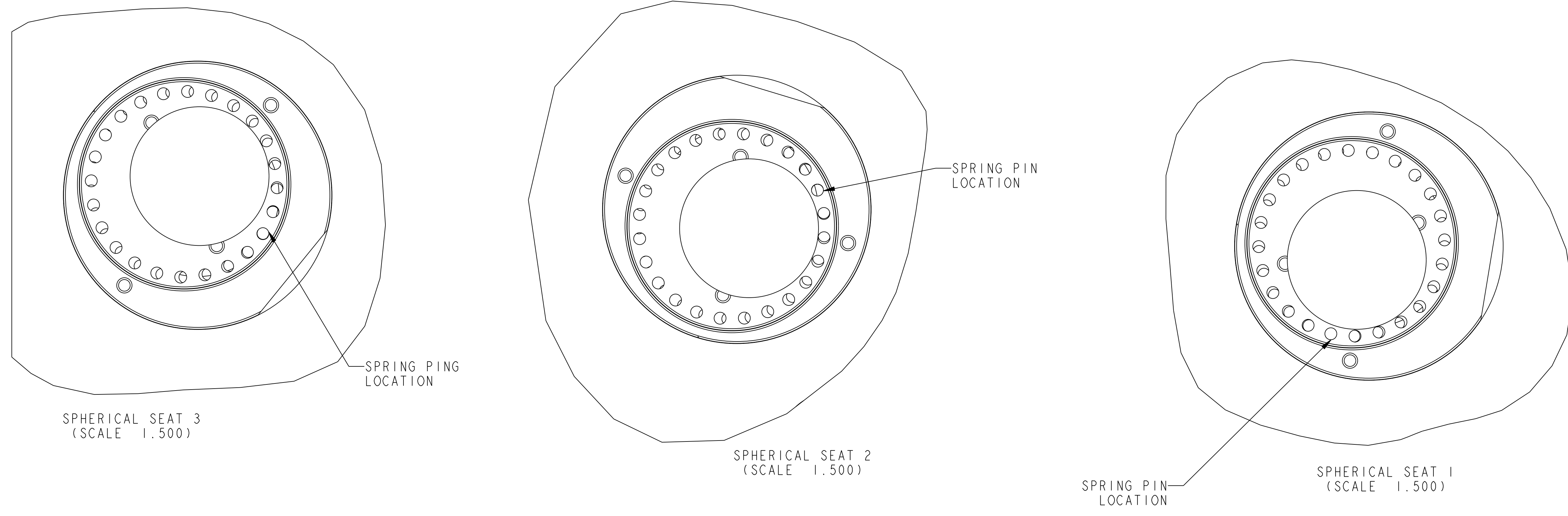

NOTE: McMASTER-CARR TOOLING BALL 8481A27 IS SHOWN

MEASUREMENT POINTS (FROM CSI ON PART -093)

ID	Pt#	X	Y	Z	R
TOOLING BALLS	1	3.387	6.059	4.195	8.1108
	2	3.536	14.538	3.607	15.3901
	3	25.576	17.450	4.175	31.2417
	4	25.314	2.488	5.212	25.9644
SPHERICAL SEAT	1	27.370	2.343	3.639	27.7100
	2	27.632	17.305	2.602	32.7069
	3	2.020	10.206	2.202	10.6344

ON PART -093, CS2 LOCATED FROM CSI AT A VALUE OF:
17.250 X, 10.000 Y, 0.0 Z, 0.0 RX, 0.0 RY, 0.0 RZ
ON PART -176, CSI LOCATED FROM CS0 AT A VALUE OF:
17.25 X, 0.005 Y, 0.0 Z, 4.000 RX, 2.000 RY, 1.000 RZ

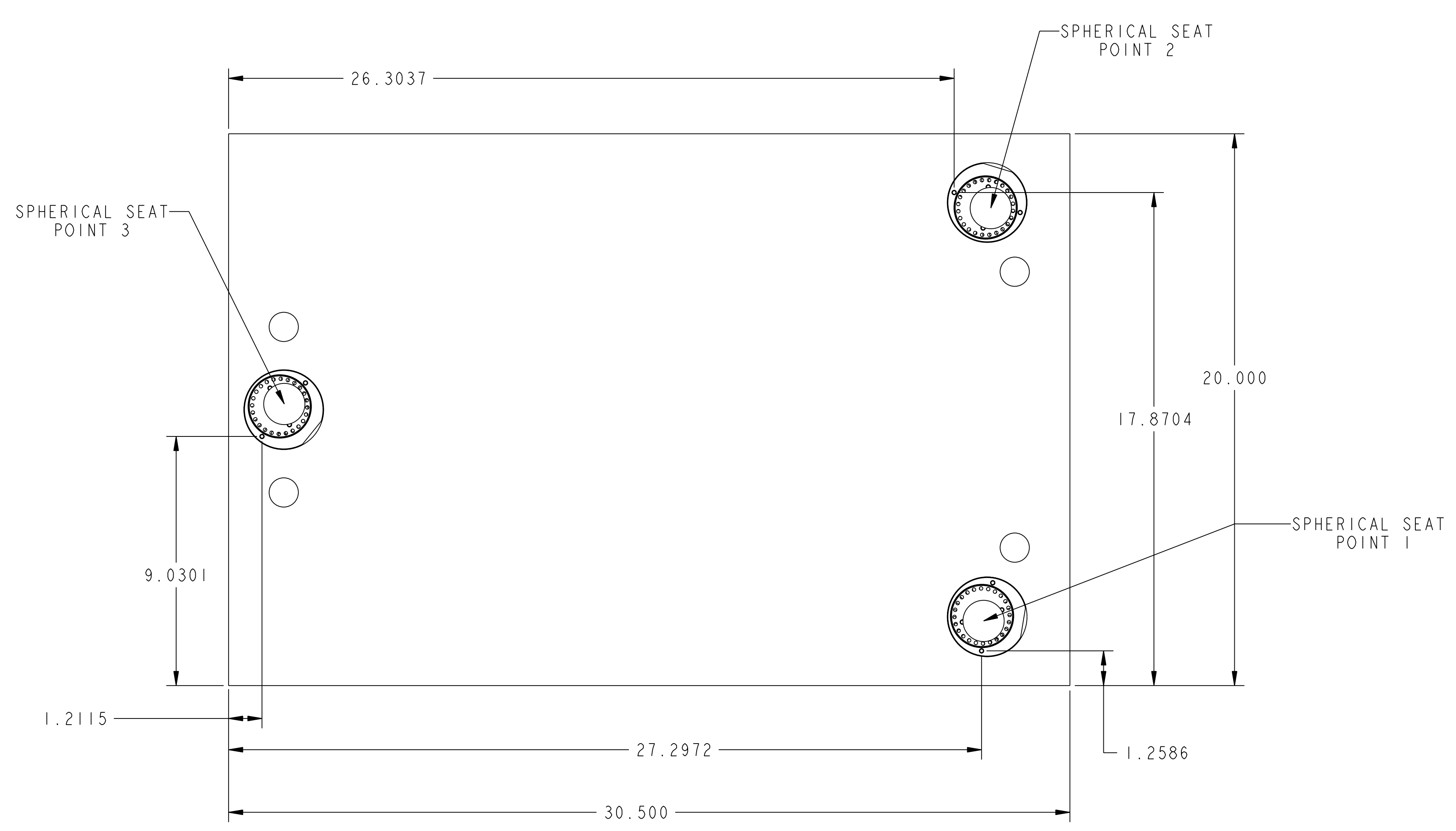

ARRANGEMENT FOR TEST SET-UP 1

DRAWING RELEASED - 10/19/06 - RI

RELEASE LEVEL: WIP
DWG VERSION NO: 0

COMPUTER GENERATED DRAWING CHANGES NOT PERMITTED Pro E DO NOT VERIFY INFORMATION BY SCALING DRAWING	CENTRAL FILES:	PRINCETON PLASMA PHYSICS LABORATORY PRINCETON UNIVERSITY	
	UNLESS OTHERWISE SPECIFIED	NATIONAL COMPACT STELLARATOR EXPERIMENT	
WEIGHT 360.6 lbs	DIMENSIONS ARE IN INCHES MACHINE SURFACES BREAK SHARP EDGES .005/.020	MODULAR COILS BALL ALIGNMENT ASSEMBLY TEST ASSEMBLY FIXTURE	
MODEL NAME SE1851-180	TOLERANCES NON-CUMULATIVE DECIMAL-INCH FRACTIONS X +/- .100 0°-120° +/- .100 XX +/- .030 120°-120° +/- .100 XXX +/- .005 120°-120° +/- .100 ANGULAR +/- .0°-15° OVER 120° +/- .100	DSN: L. MORRIS CHK: ENGR: T. BROWN SUPV:	DRAWING NO: SE1851-180 SHEET 1 OF 1 REV 0

NCSX-SE1851-180