

- NOTES:
- DRAWING DEPICTS FLAT PATTERN OF FORMED PARTS DEFINED BY PRO/ENGINEER FILES SE310-030-B\*.PRT.
  - THE MATERIAL USED SHALL BE COPPER ALLOY UNS C 11000, ANNEALED OR 1/8 HARD (H00-TEMPER) PER ASTM B370 OR ASTM B152
  - MACHINED EDGES ARE TO BE DEBURRED AND SMOOTH TO PRECLUDE INJURY FROM HANDLING.
  - PART NUMBERS AND ALIGNMENT ARROWS ARE TO BE PERMANENTLY MECHANICALLY ETCHED INTO THE TEMPLATE SURFACE EXACTLY AS SHOWN IN THE DRAWING. SOME TEMPLATES HAVE TWO TAG NUMBERS AND ALIGNMENT ARROWS. TAG NUMBERS AND ARROWS ARE USED TO ORIENT THE TEMPLATE DURING INSTALLATION.
  - HANDLING AND PROCESSING SHALL BE CONTROLLED TO MINIMIZE WORK HARDENING.
  - THE EDGES ARE TO BE PERPENDICULAR TO THE TEMPLATE SURFACE TO + OR - 5 DEGREES (+ OR - 0.004 INCH) MACHINED TEMPLATES ARE TO BE DELIVERED TO PPPL WITH THE SAME TEMPER AS THE STOCK SHEETS (RAW MATERIAL). IT IS RECOGNIZED THAT THE CUT EDGES MAY BE SLIGHTLY HARDENED FROM THE CUTTING PROCESS.
  - COATING THE SURFACE TO FACILITATE MACHINING IS PERMITTED. THE TEMPLATES ARE USED TO LOCATE AND WIND MAGNETIC COILS AND ARE REMOVED AFTERWARD.
  - THE LOCATOR SEMICIRCULAR HOLES AND THEIR RESPECTIVE LOCATIONS ARE TO BE POSITIONED TO + OR - 0.005 INCH AND VERIFIED BY INSPECTION. THE GENERAL TEMPLATE DIMENSIONS ARE TO BE WITHIN + OR - 0.020 INCH OF THE IDEAL GEOMETRY (DXF MODEL). THE PPPL PROVIDED E-SIZE DRAWINGS WITH FULL SCALE TEMPLATES ARE TO BE USED BY THE VENDOR AS A "GO- NO GO" GAUGE.

NOTCH LOCATION AND QUANTITY VARIES BY PART

DETAIL A  
SCALE 5.000

SEE DETAIL A

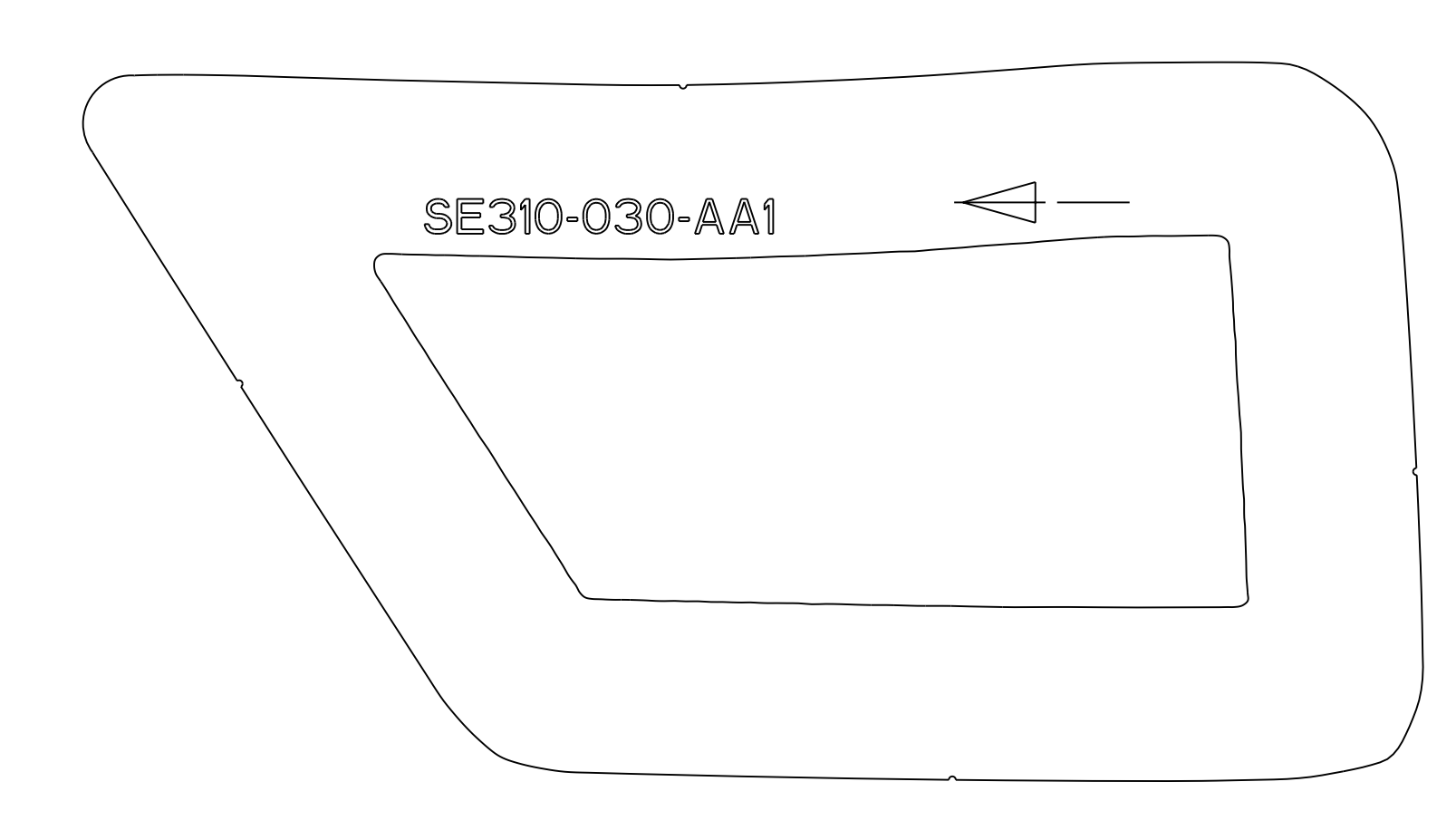

SE310-030-AA1  
QNTY 1

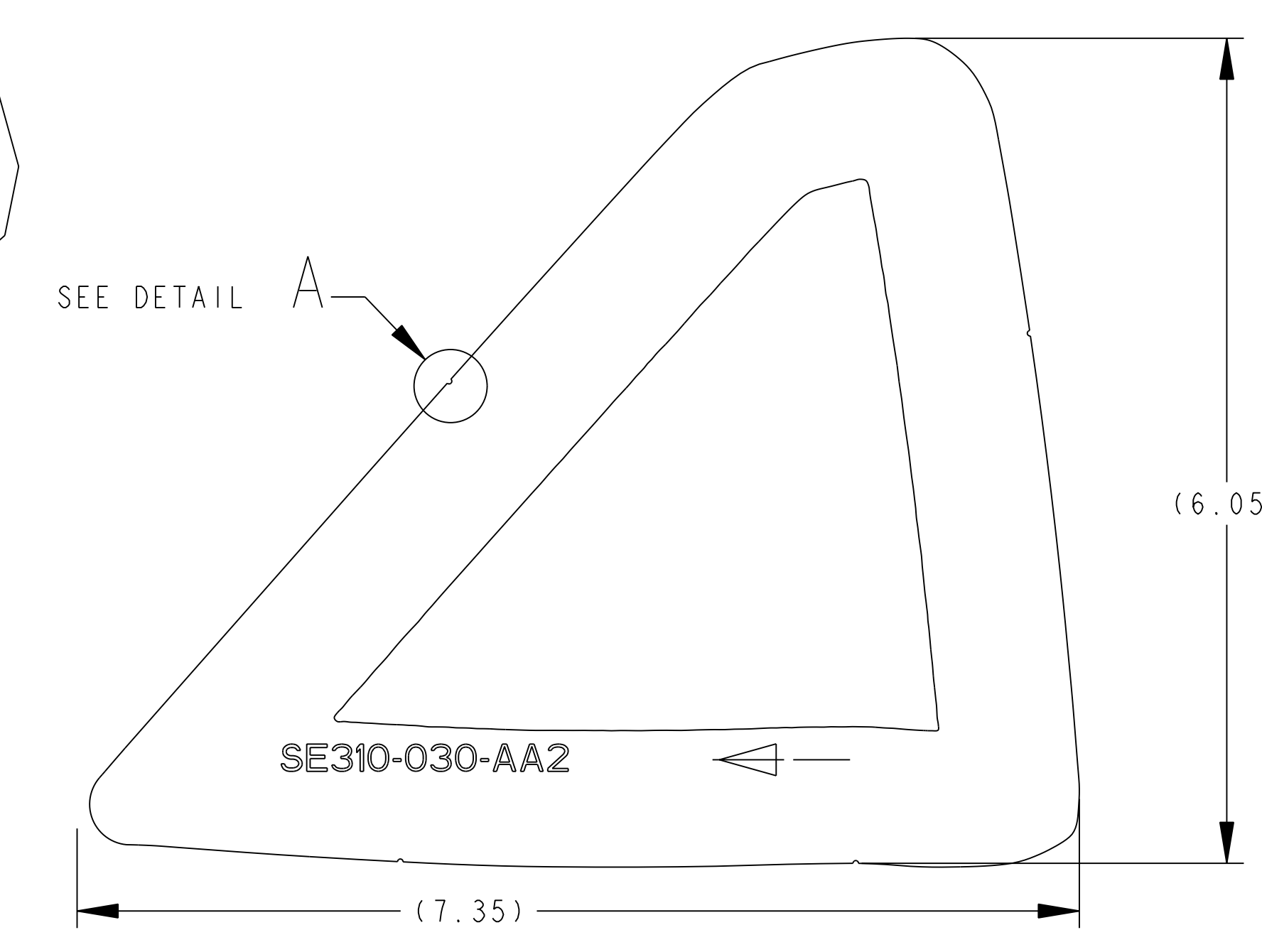

SE310-030-AA2  
QNTY 1

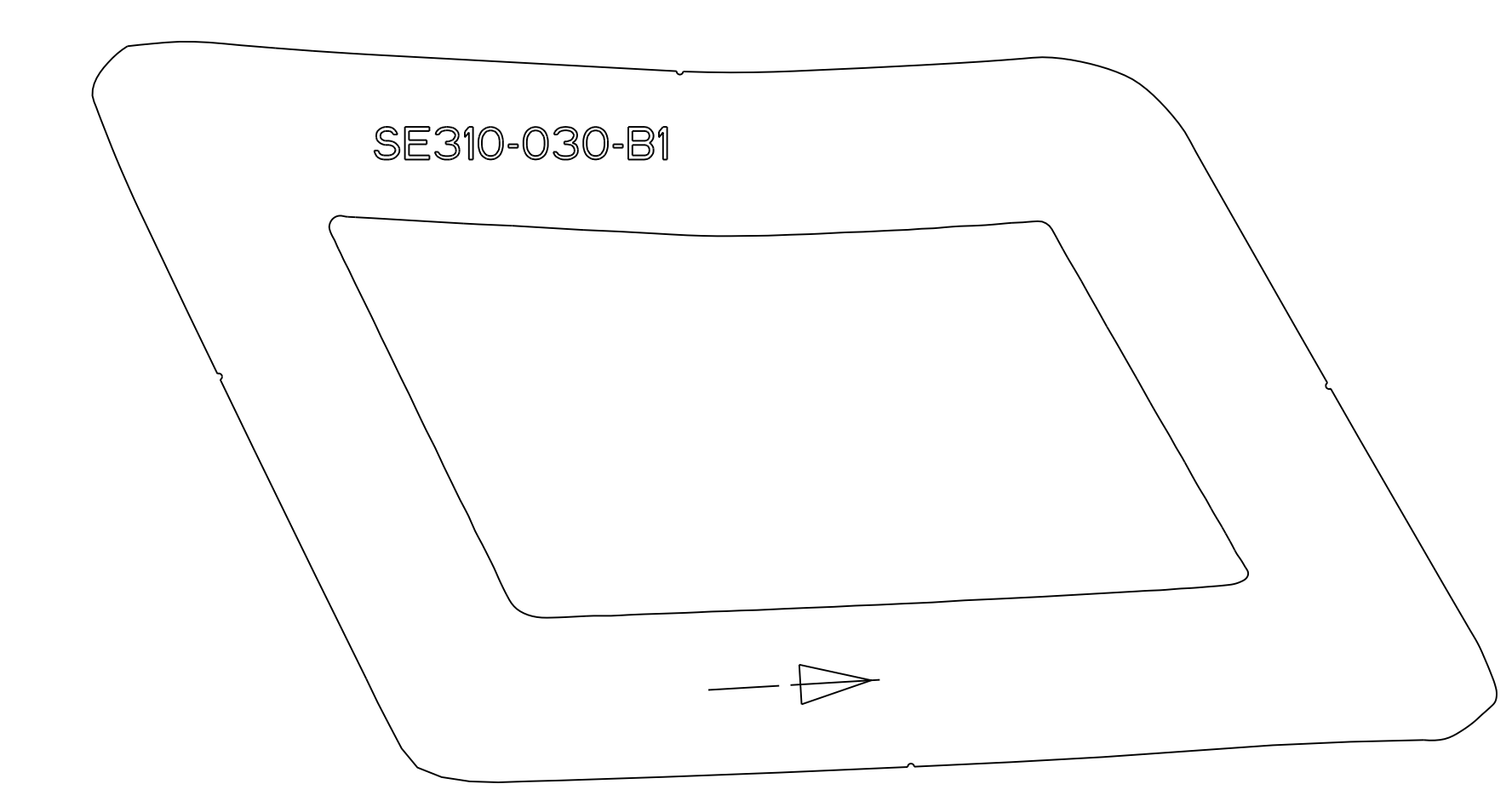

SE310-030-B1  
QNTY 1

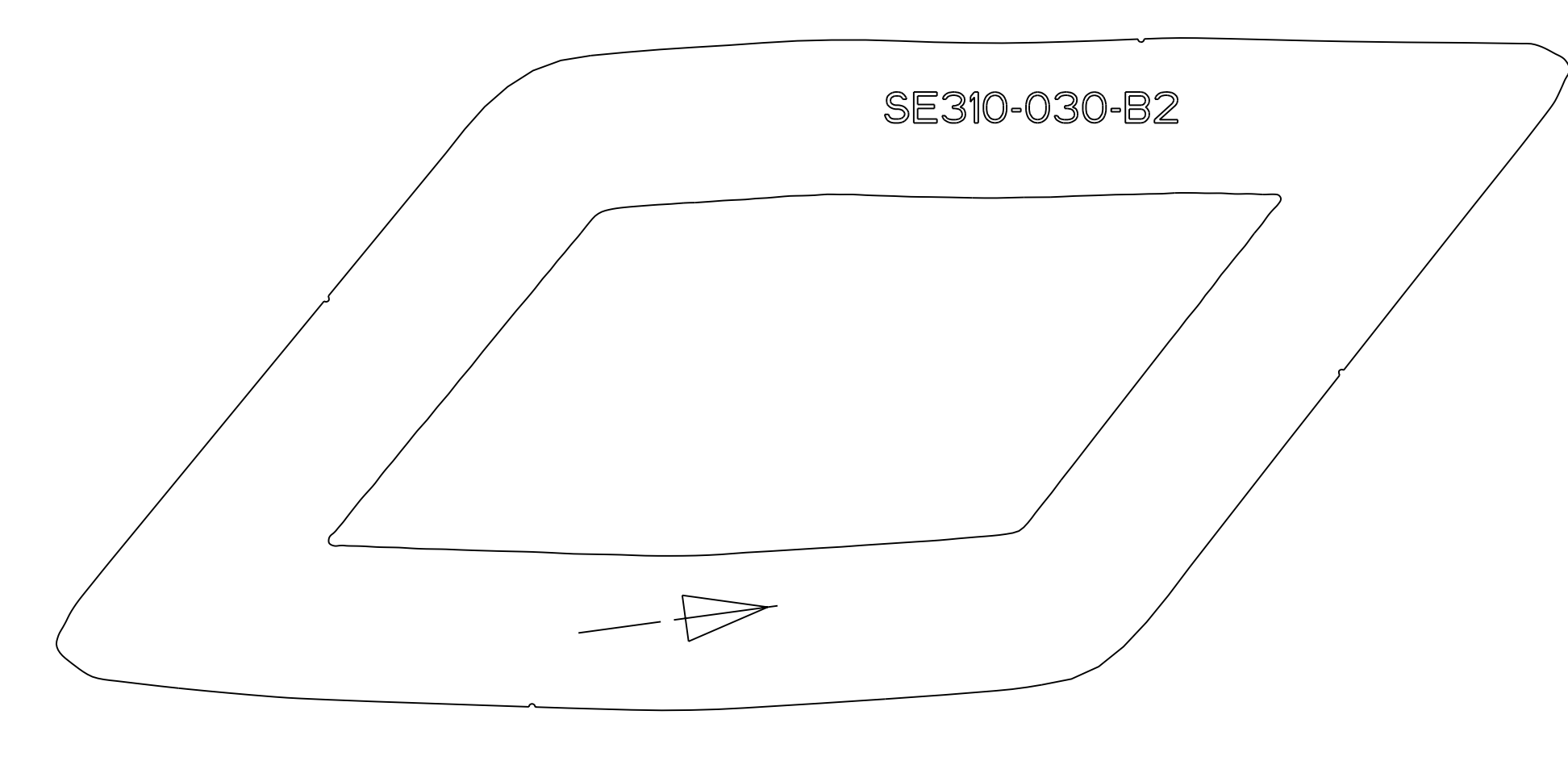

SE310-030-B2  
QNTY 1

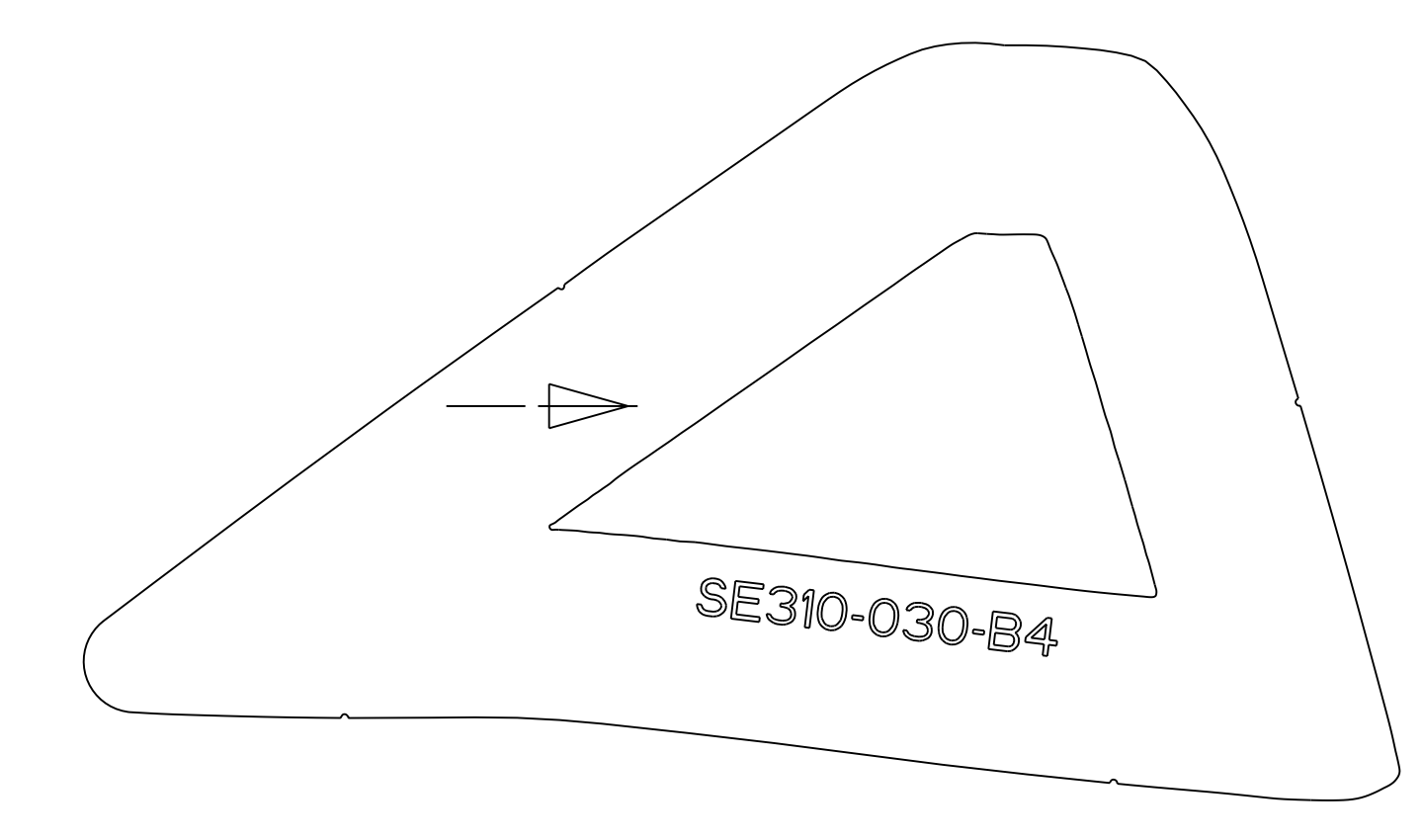

SE310-030-B4  
QNTY 1

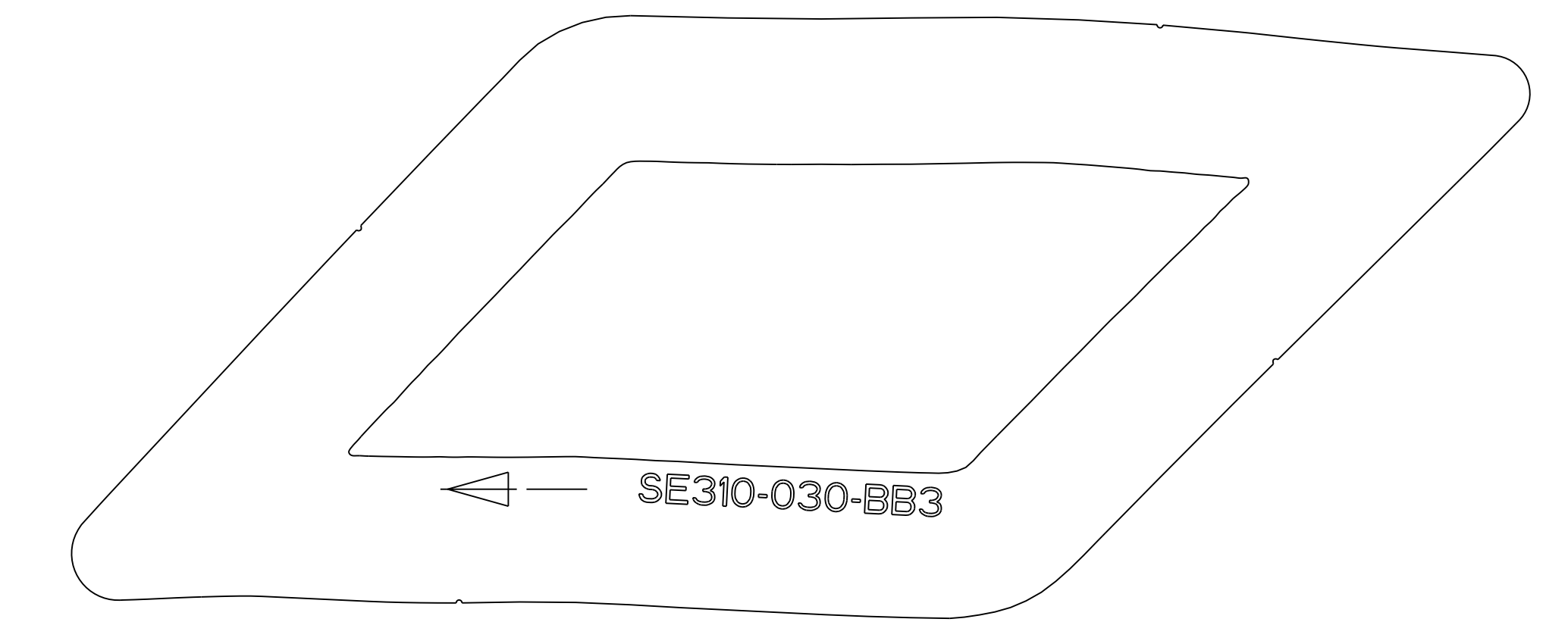

SE310-030-BB3  
QNTY 1

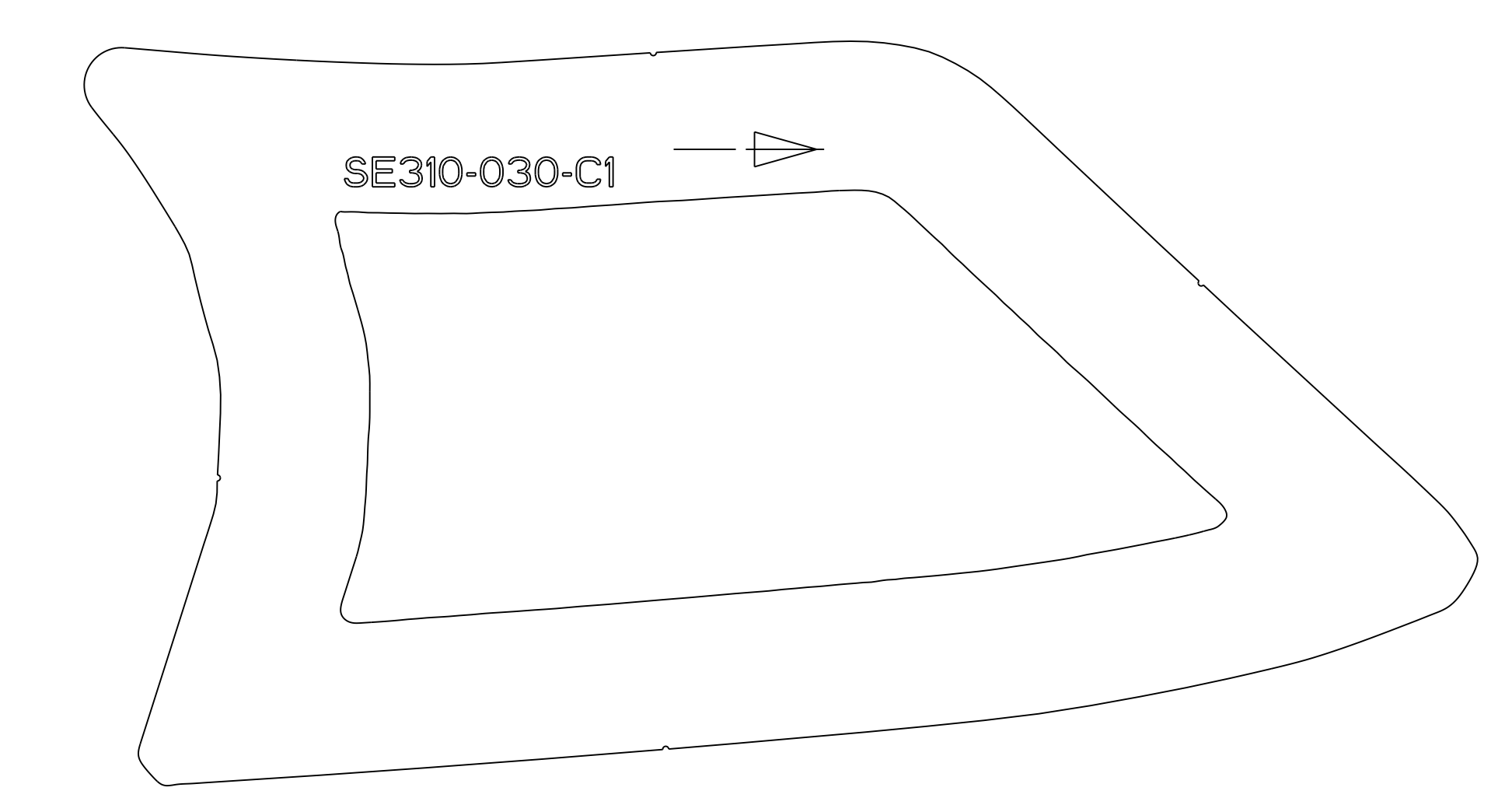

SE310-030-C1  
QNTY 1

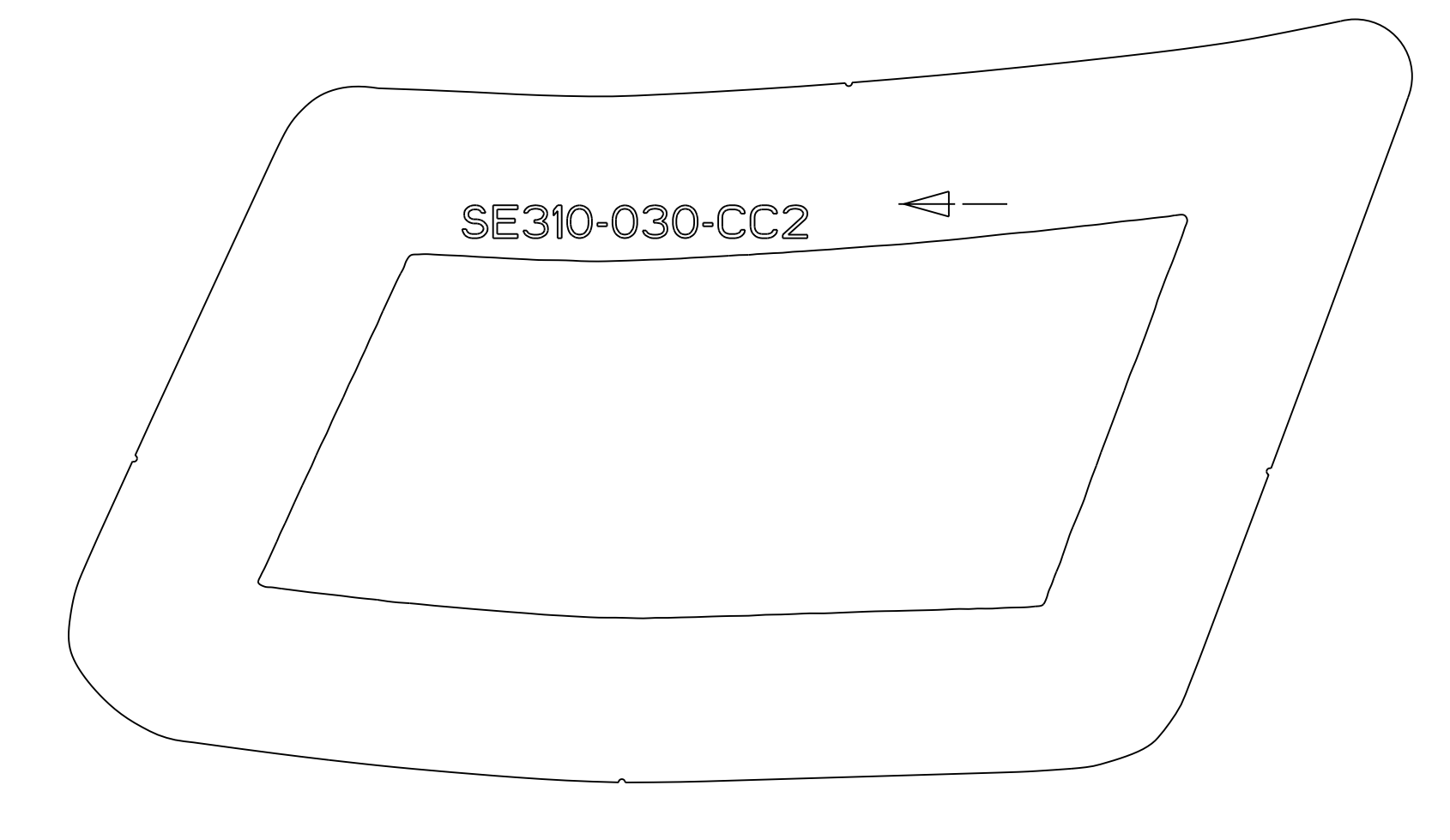

SE310-030-CC2  
QNTY 1

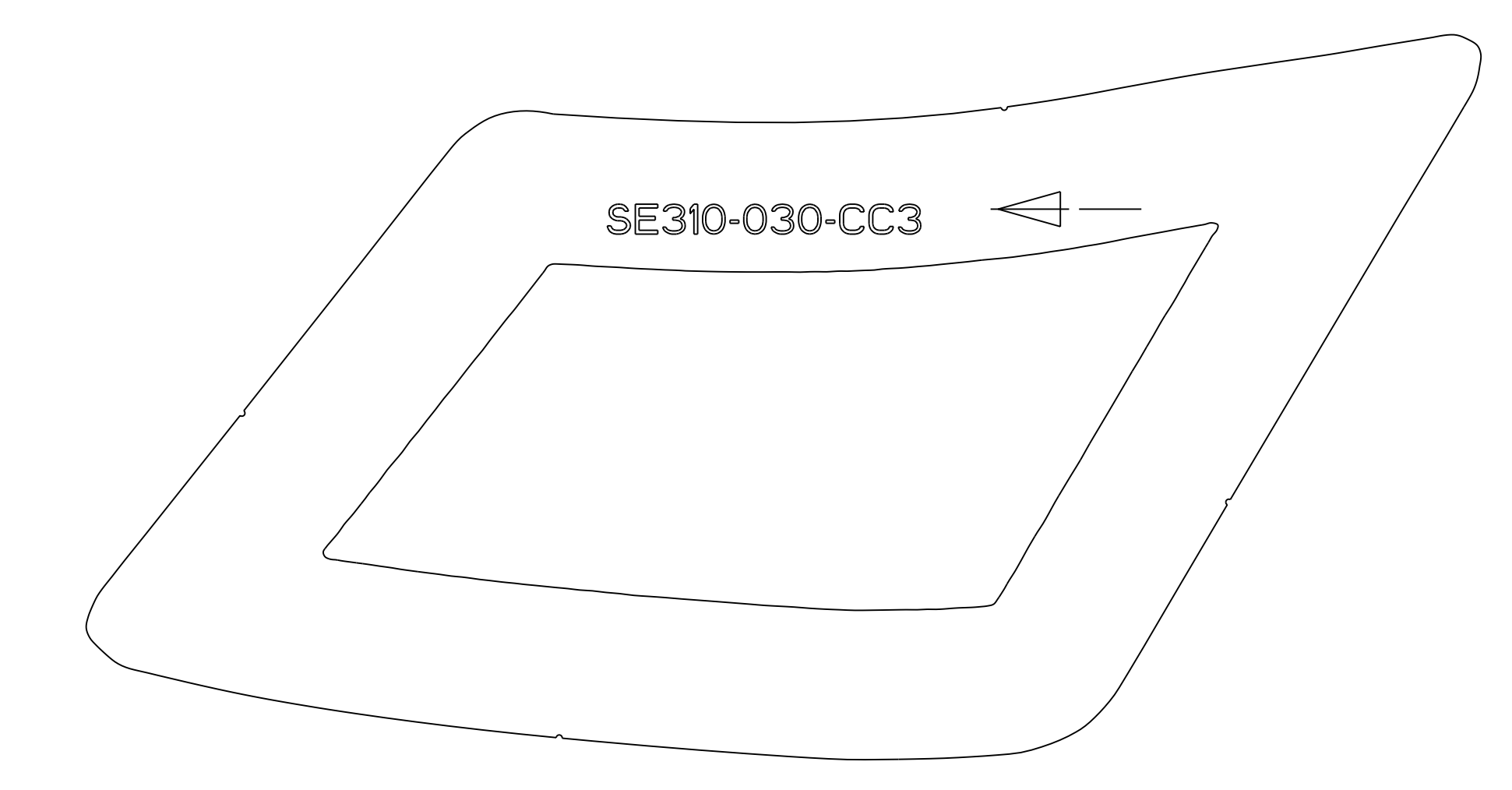

SE310-030-CC3  
QNTY 1

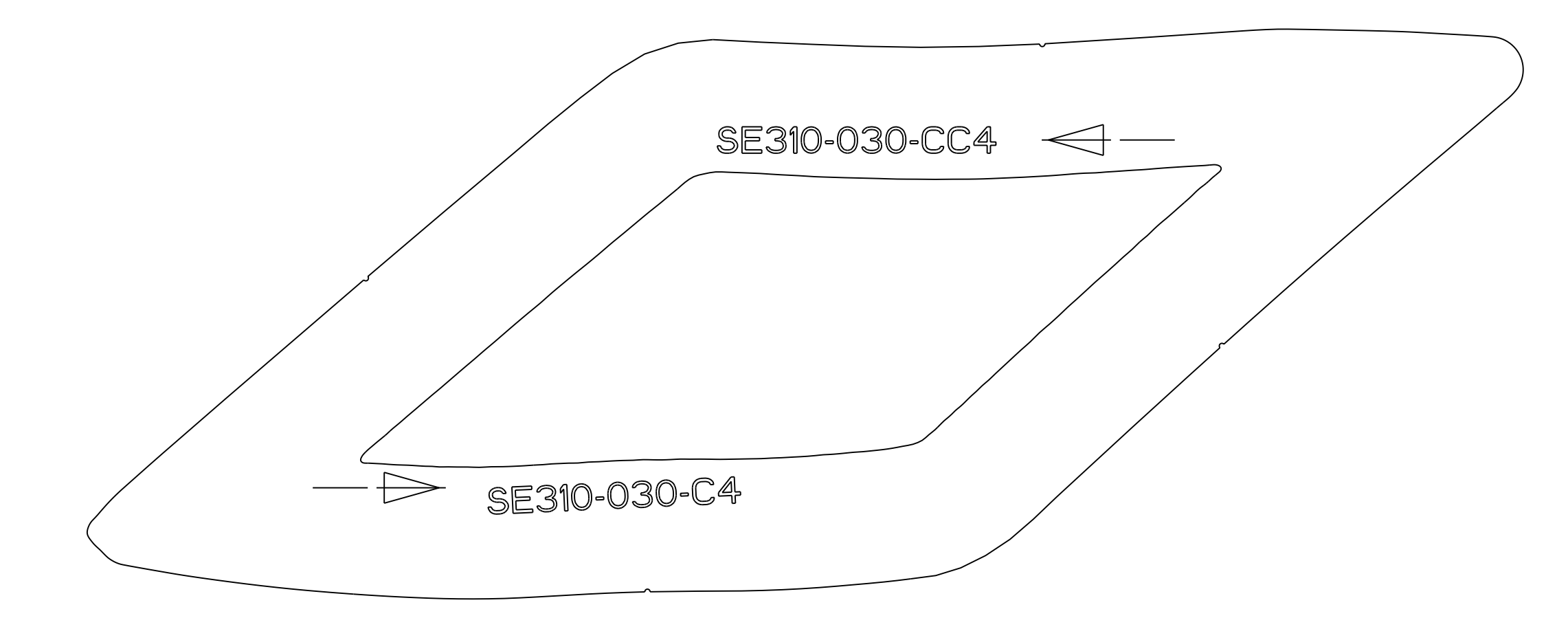

SE310-030-CC4  
QNTY 2

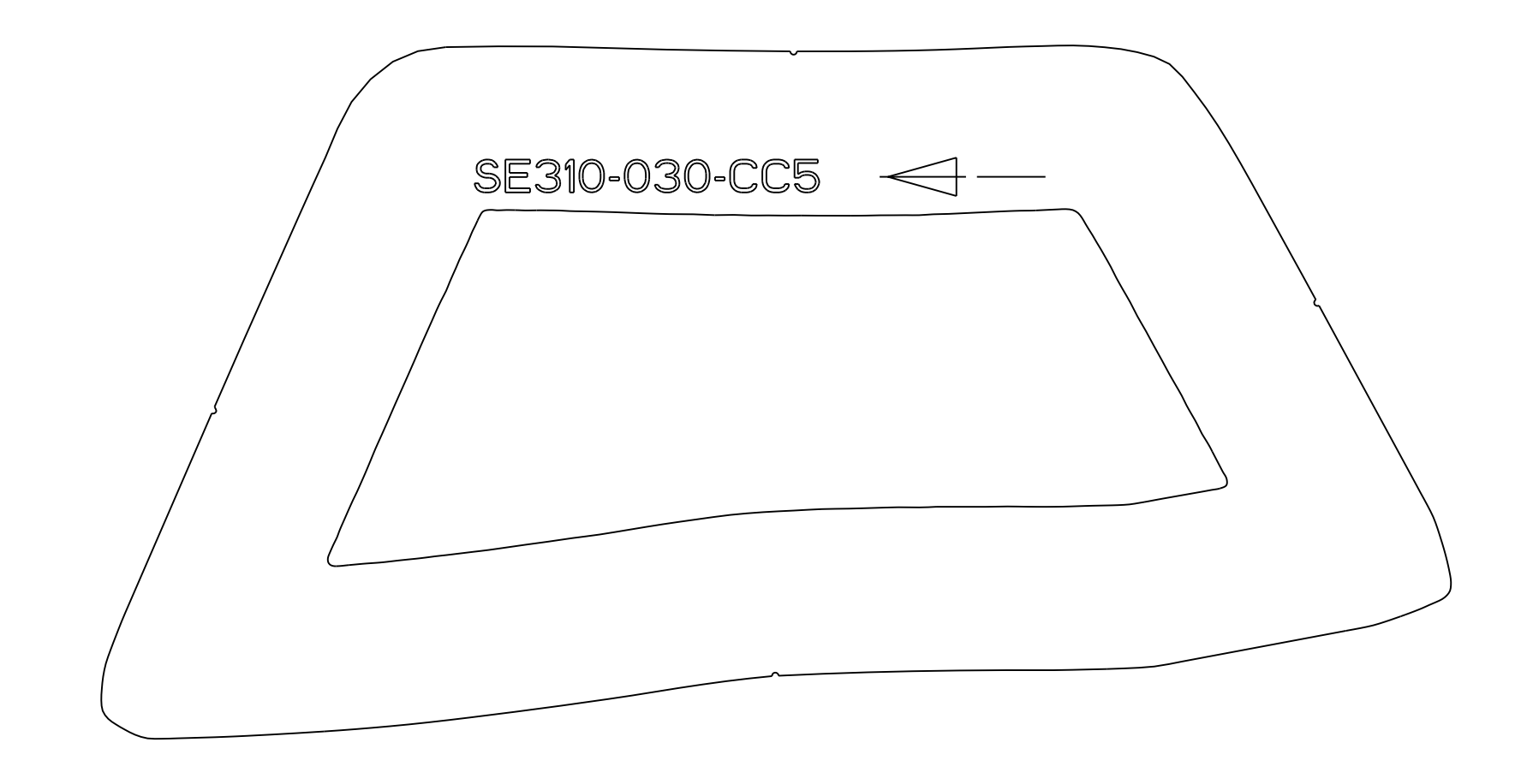

SE310-030-CC5  
QNTY 1

RELEASE LEVEL:  
DWG VERSION NO:

WEIGHT  
0.0 lbs  
MODEL NAME  
SE310-030-C1  
WELDING  
ENGINEER

PART NO.	DRAWING NO	NOMENCLATURE OR DESCRIPTION	MATERIAL	QTY REOD
PARTS LIST				
COMPUTER GENERATED DRAWING MANUAL CHANGES NOT PERMITTED Pro E		CENTRAL FILES: UNLESS OTHERWISE SPECIFIED DIMENSIONS ARE IN INCHES MACHINE SURFACES BREAK SHARP EDGES .005/0.020	PRINCETON PLASMA PHYSICS LABORATORY PRINCETON UNIVERSITY NATIONAL COMPACT STELLARATOR EXPERIMENT DIAGNOSTICS MAGNETIC LOOP SERIES "A THRU C"	
DO NOT VERIFY INFORMATION BY SCALING DRAWING	TOLERANCES NON-CUMULATIVE DECIMAL-INCH FRACTIONS .XX +/- .000 .XXX +/- .005 ANGULAR +/- 0°15'	DSN: T. BROWN CHK: J. RUSHINSKI ENGR: G. LABIK SUPV: J. SIEGEL	1/12/06 1/12/06 1/12/06 1/12/06	DRAWING NO: <b>SE310-030-A Q</b> SHEET 1 OF 15 REV 0

NCSX-SE310-030-A-Q

NO.	REVISION	BY	CH	SUP	APPROVED	DATE

FOR NOTES SEE SHEET 1

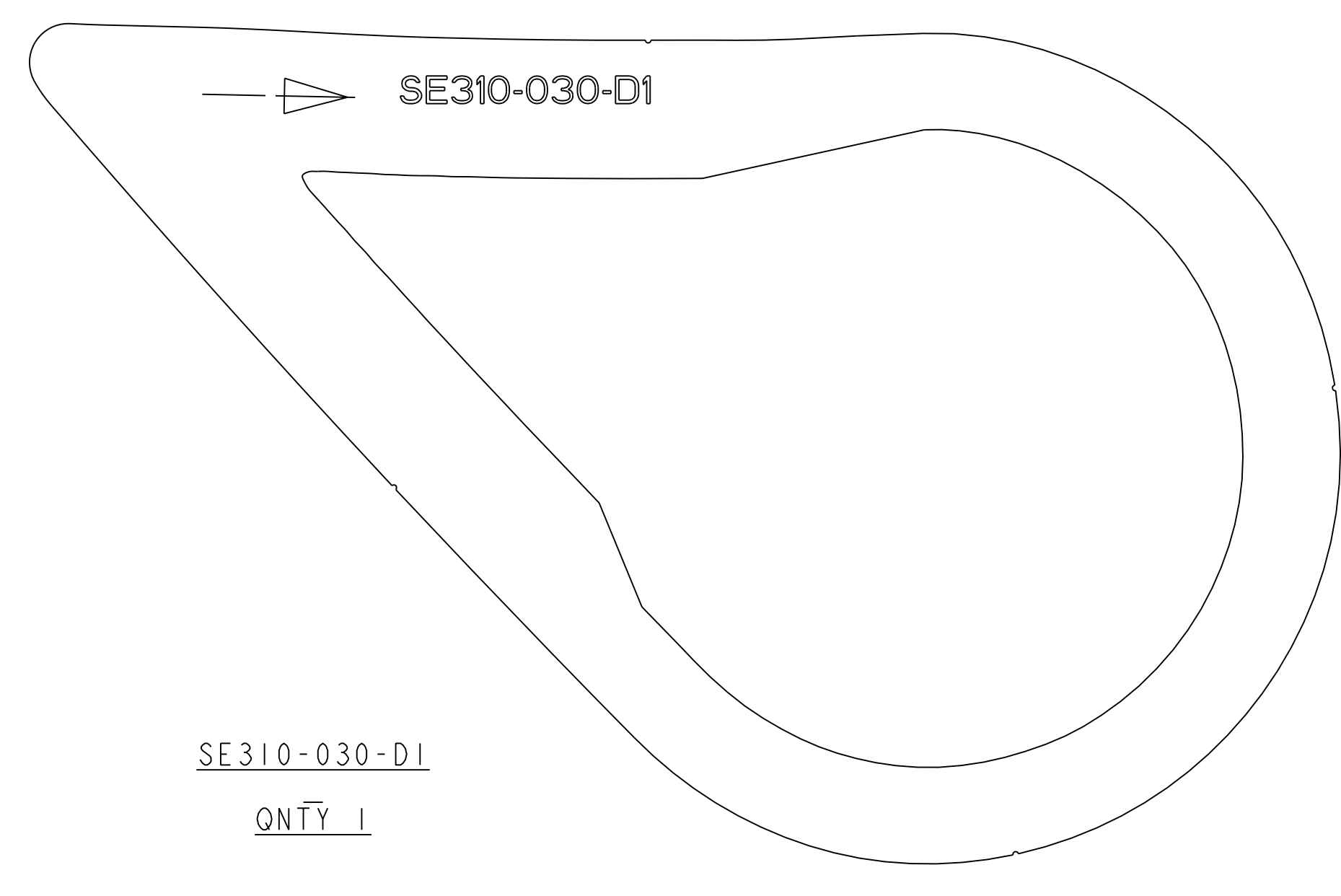

SE310-030-D1  
QNTY 1

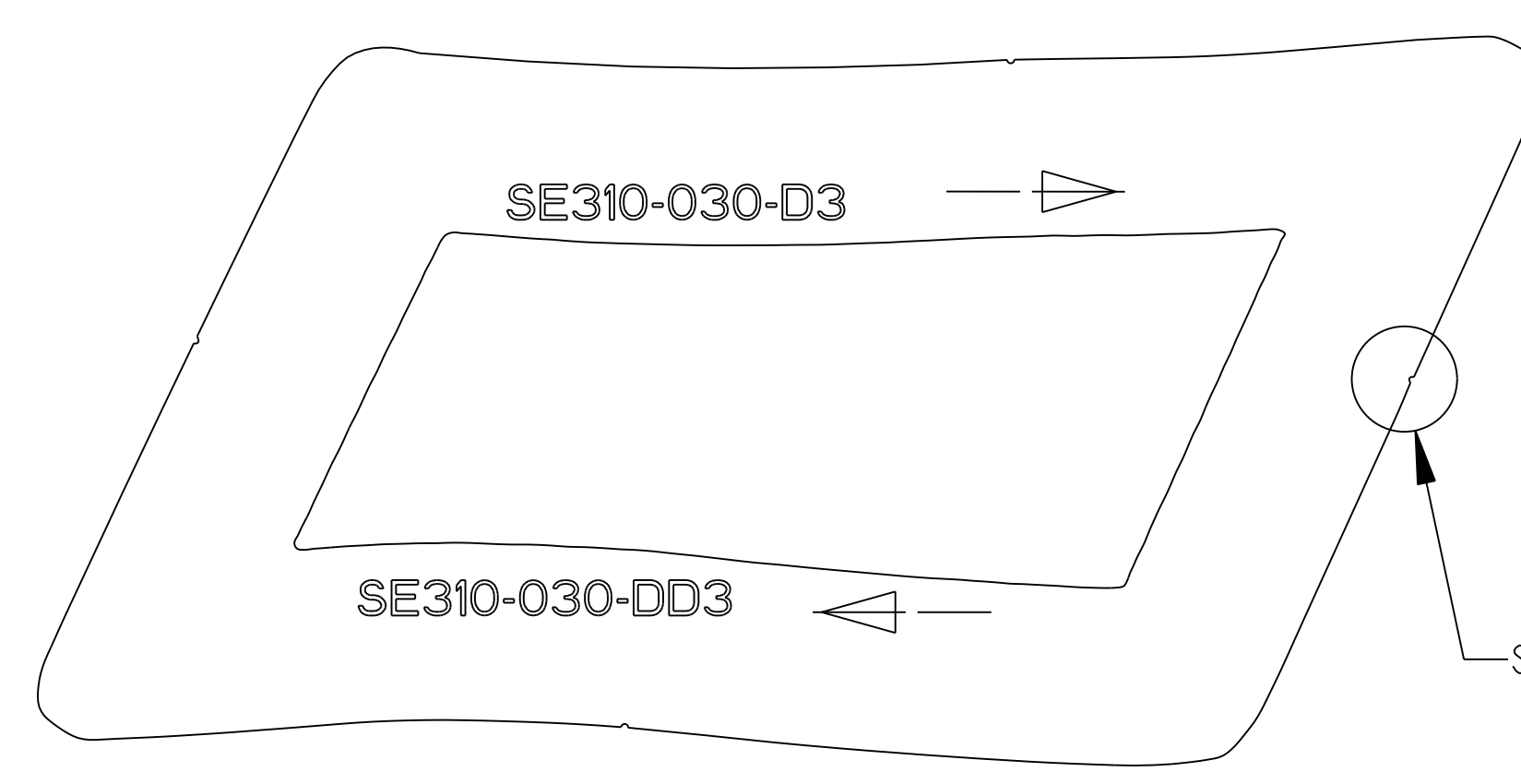

SE310-030-D3  
QNTY 1

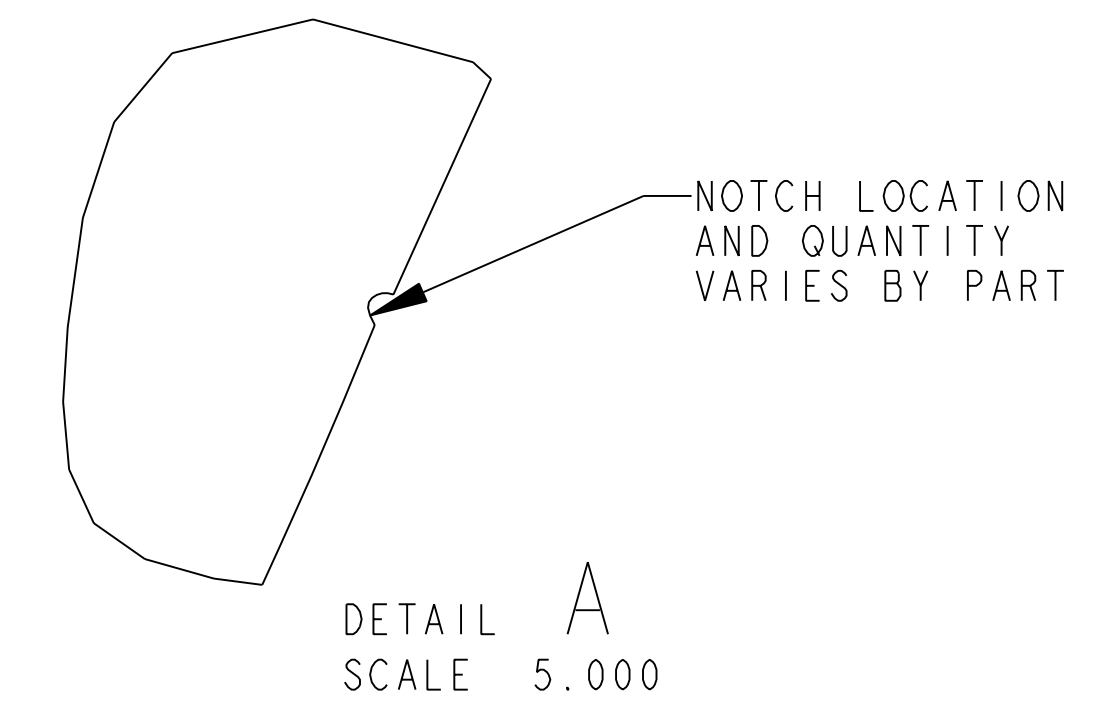

SEE DETAIL A

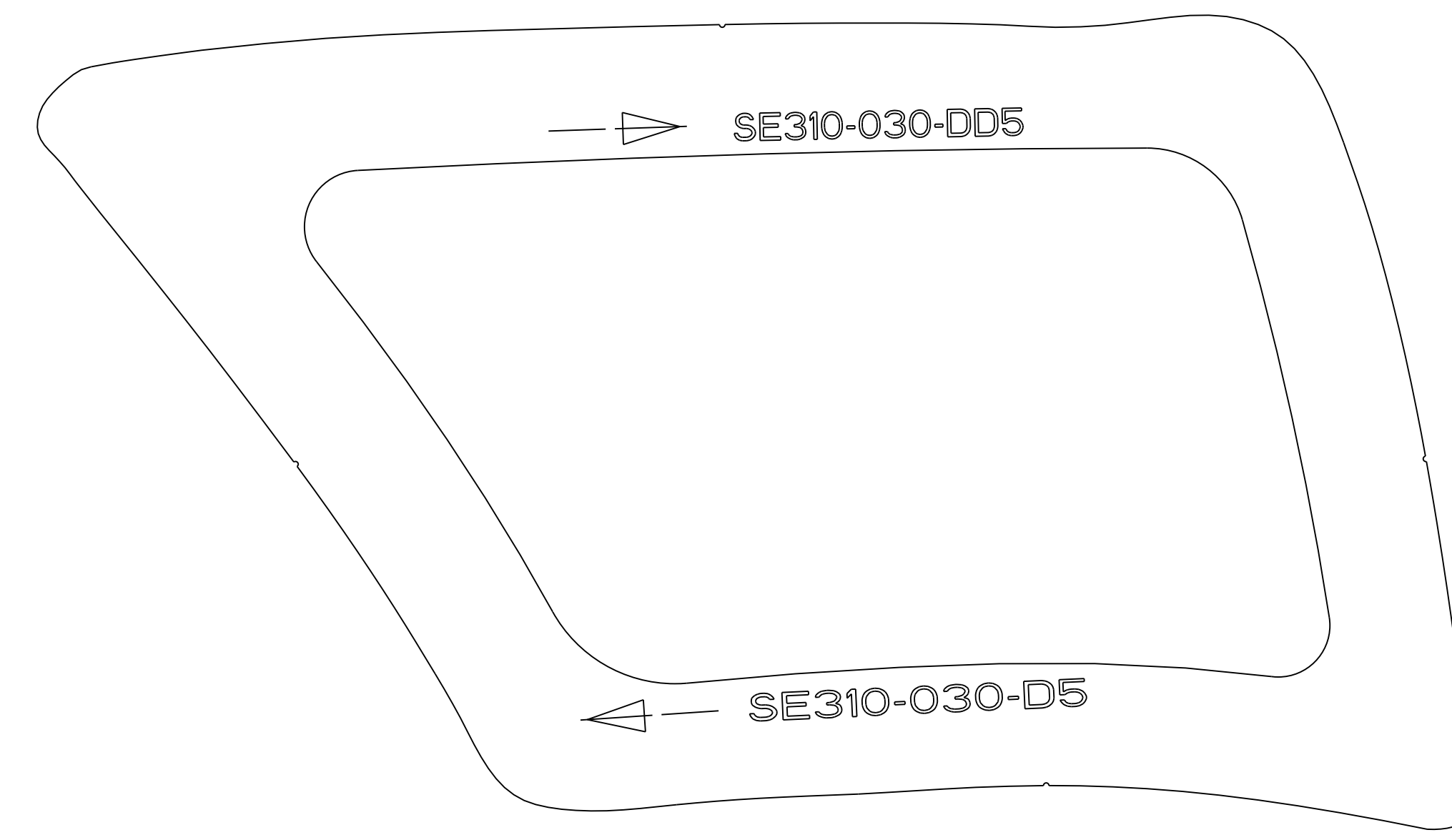

SE310-030-D5  
QNTY 2

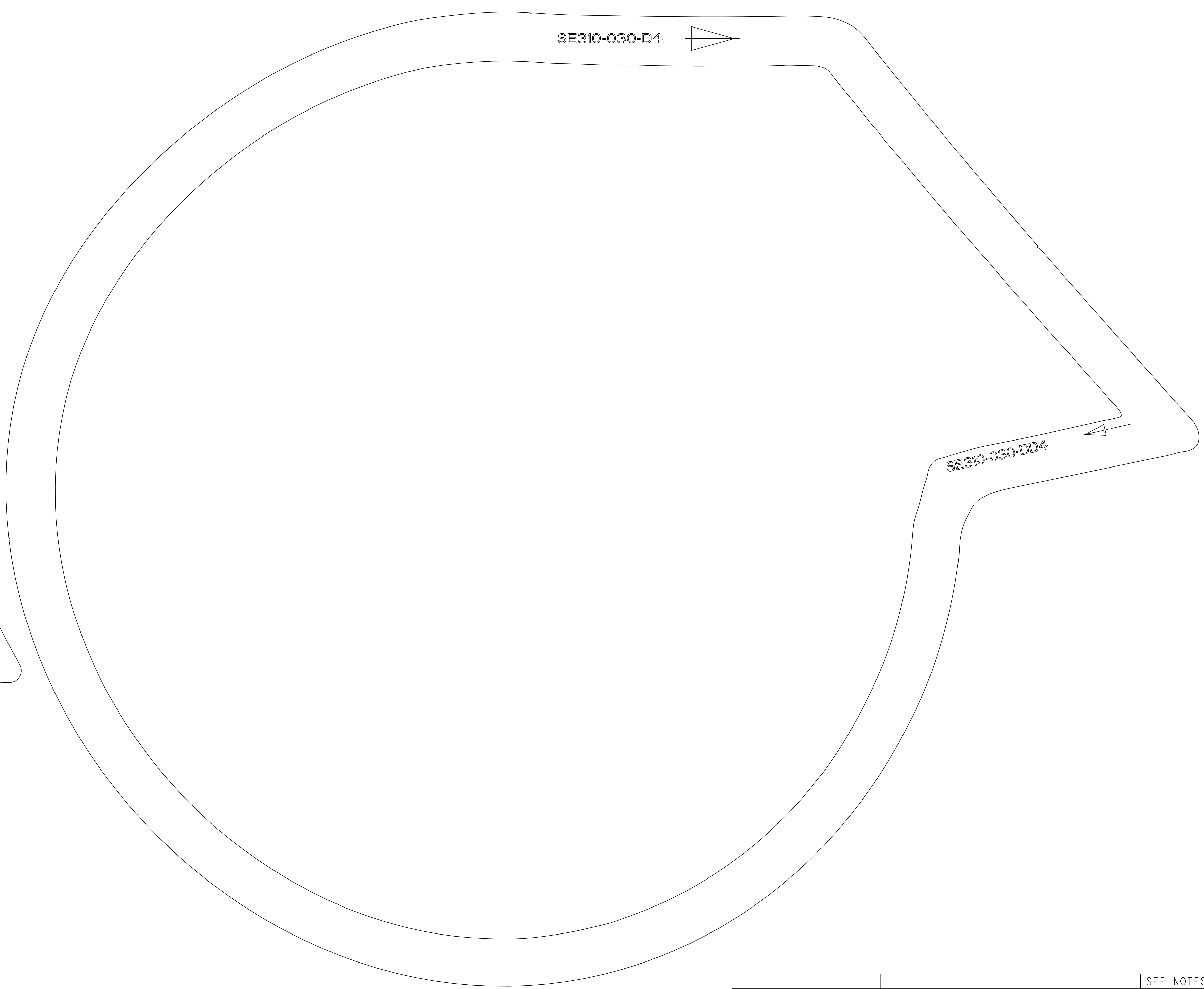

SE310-030-DD4

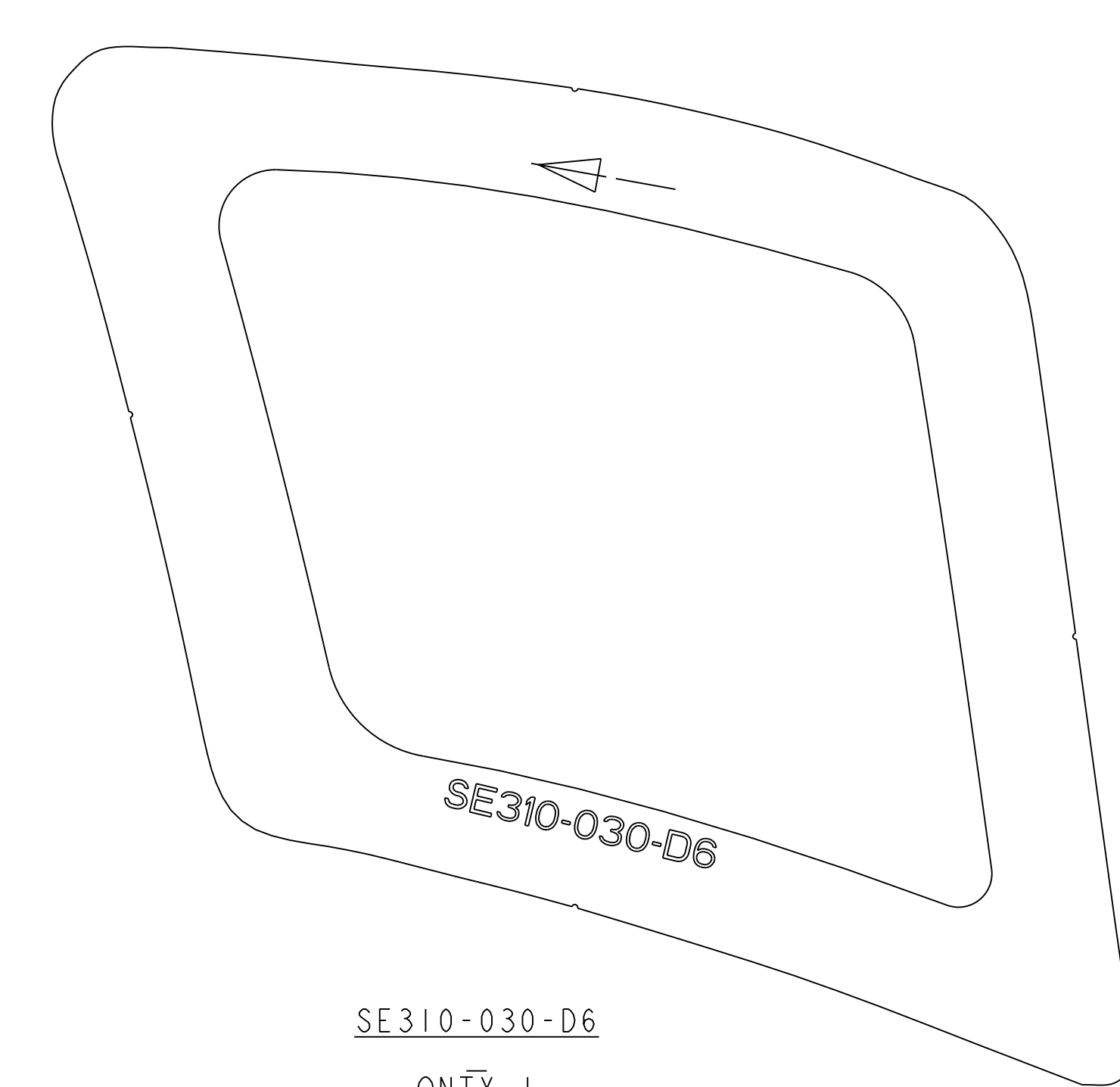

SE310-030-D6  
QNTY 1

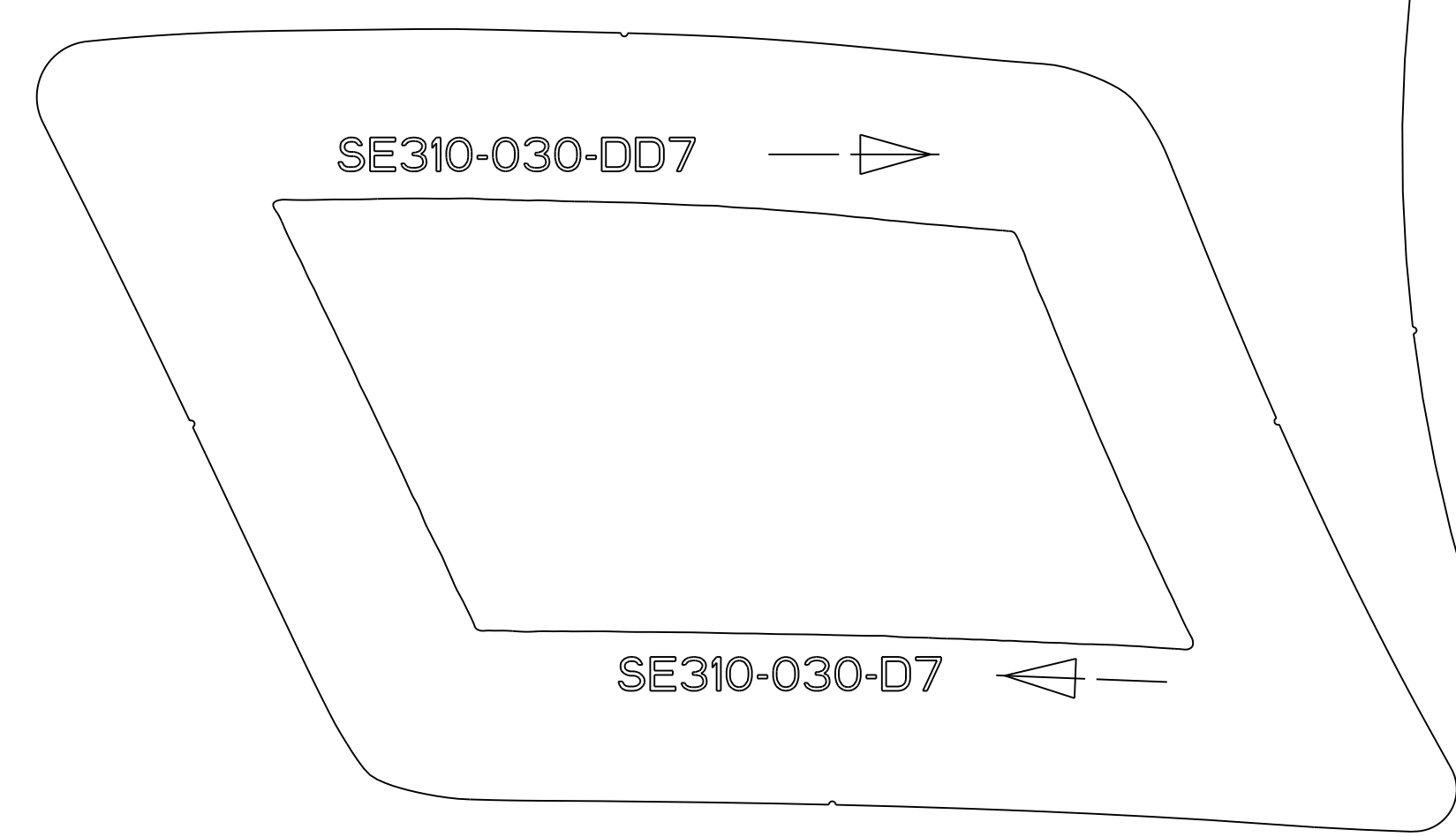

SE310-030-D7  
QNTY 2

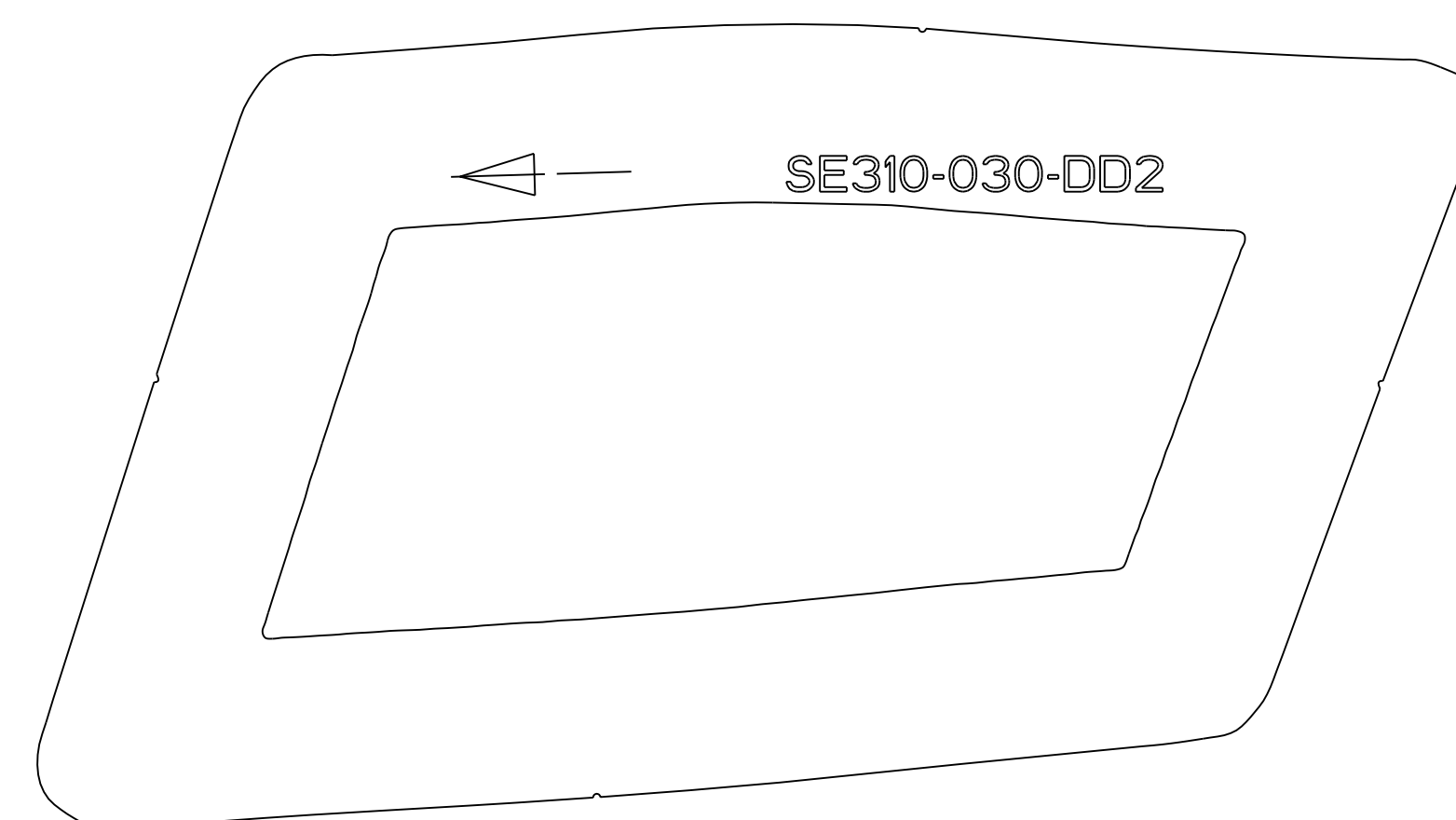

SE310-030-DD2  
QNTY 1

SE310-030-D4  
QNTY 1

RELEASE LEVEL:  
DWG VERSION NO:

WEIGHT  
0.0 lbs

MODEL NAME  
SE310-030-HH7

WELDING ENGINEER

PART NO.	DRAWING NO	NOMENCLATURE OR DESCRIPTION	MATERIAL	QTY RECD	SEE NOTES
PARTS LIST					
COMPUTER GENERATED DRAWING DRAWING CHANGES NOT PERMITTED Pro E		CENTRAL FILES: UNLESS OTHERWISE SPECIFIED	PRINCETON PLASMA PHYSICS LABORATORY PRINCETON UNIVERSITY NATIONAL COMPACT STELLARATOR EXPERIMENT		
DO NOT VERIFY INFORMATION BY SCALING DRAWING		DIMENSIONS ARE IN INCHES MACHINE SURFACES BREAK SHARP EDGES .005/ .020	DIAGNOSTICS MAGNETIC DIAGNOSTICS MAGNETIC LOOPS SERIES "D"		
NEXT ASSEMBLY		TOLERANCES NON-CUMULATIVE DECIMAL-INCH FRACTIONS .XX +/- .000 0°-12° +/- .010 .XXX +/- .005 12°-120° +/- .010 ANGULAR +/- 0°-15° OVER 120° +/- .125	DSN: T. BROWN 1/12/06	CHK: J. RUSHINSKI 1/12/06	DRAWING NO: <b>SE310-030-A.Q</b>
			ENGR: G. LABIK 1/12/06	SUPV: J. SEIGEL 1/12/06	SHEET 2 OF 15 REV 0

NCSX-SE310-030-A.Q

NO.	REVISION	BY	CH	SUP	APPROVED	DATE

FOR NOTES SEE SHEET 1

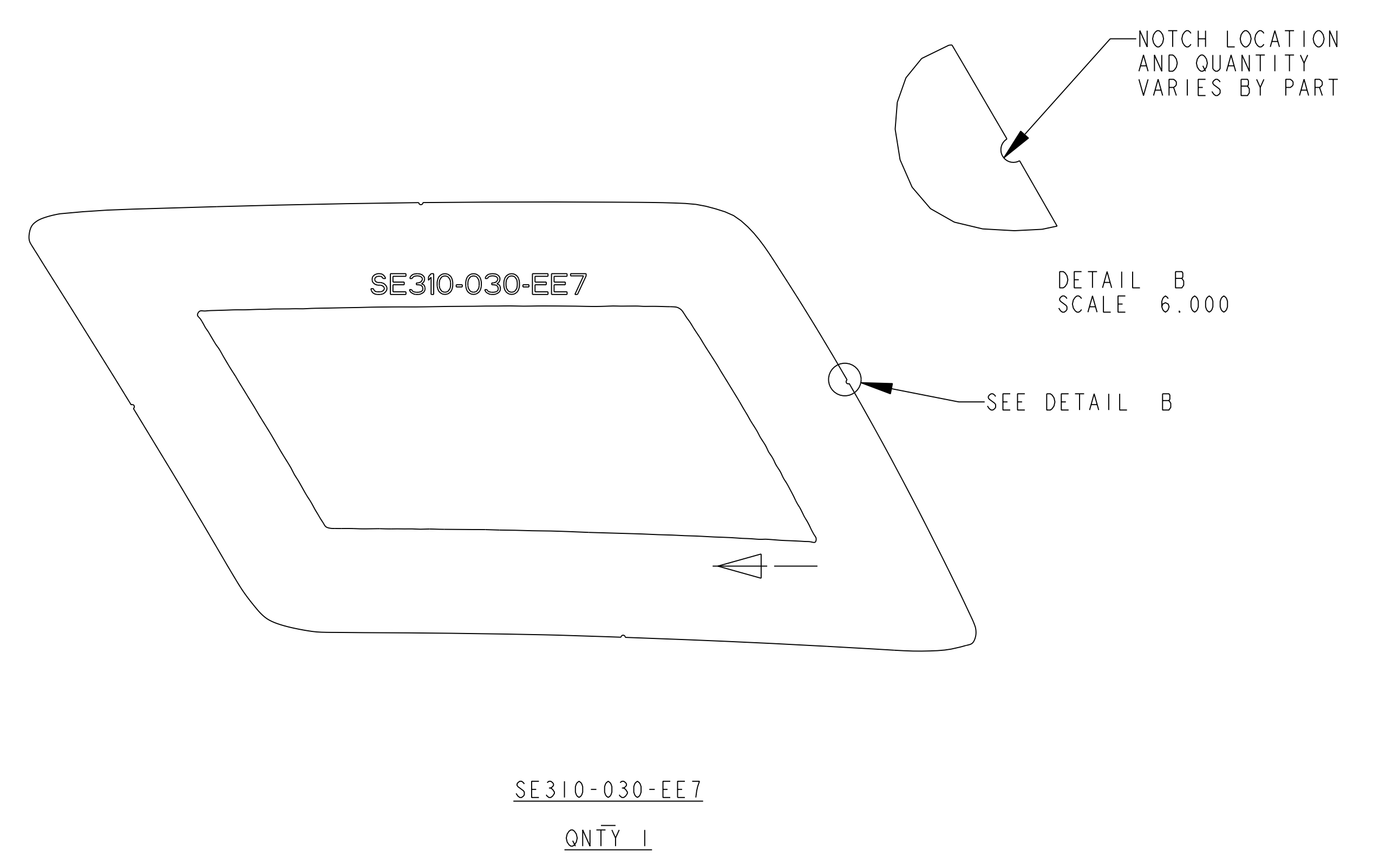
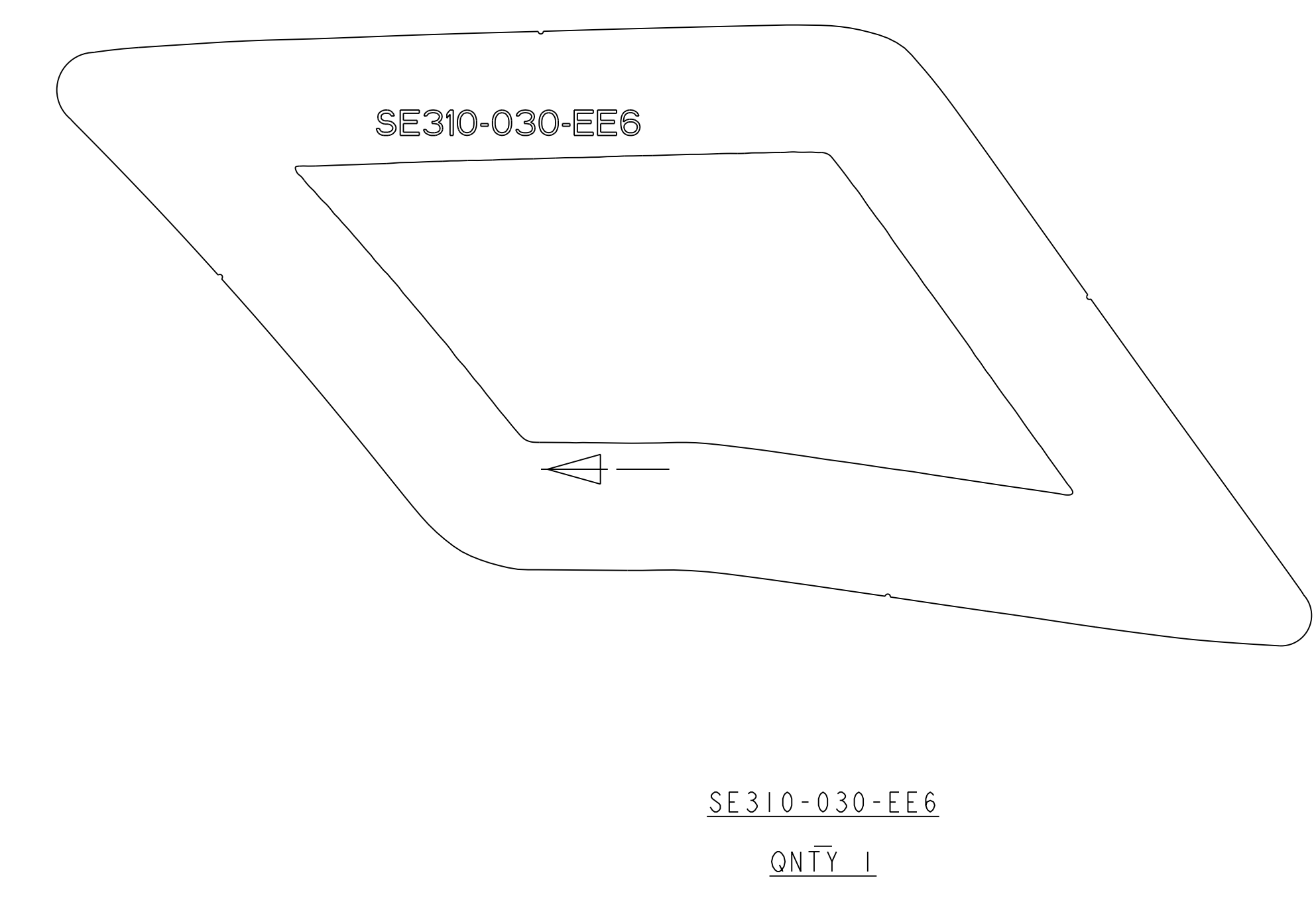
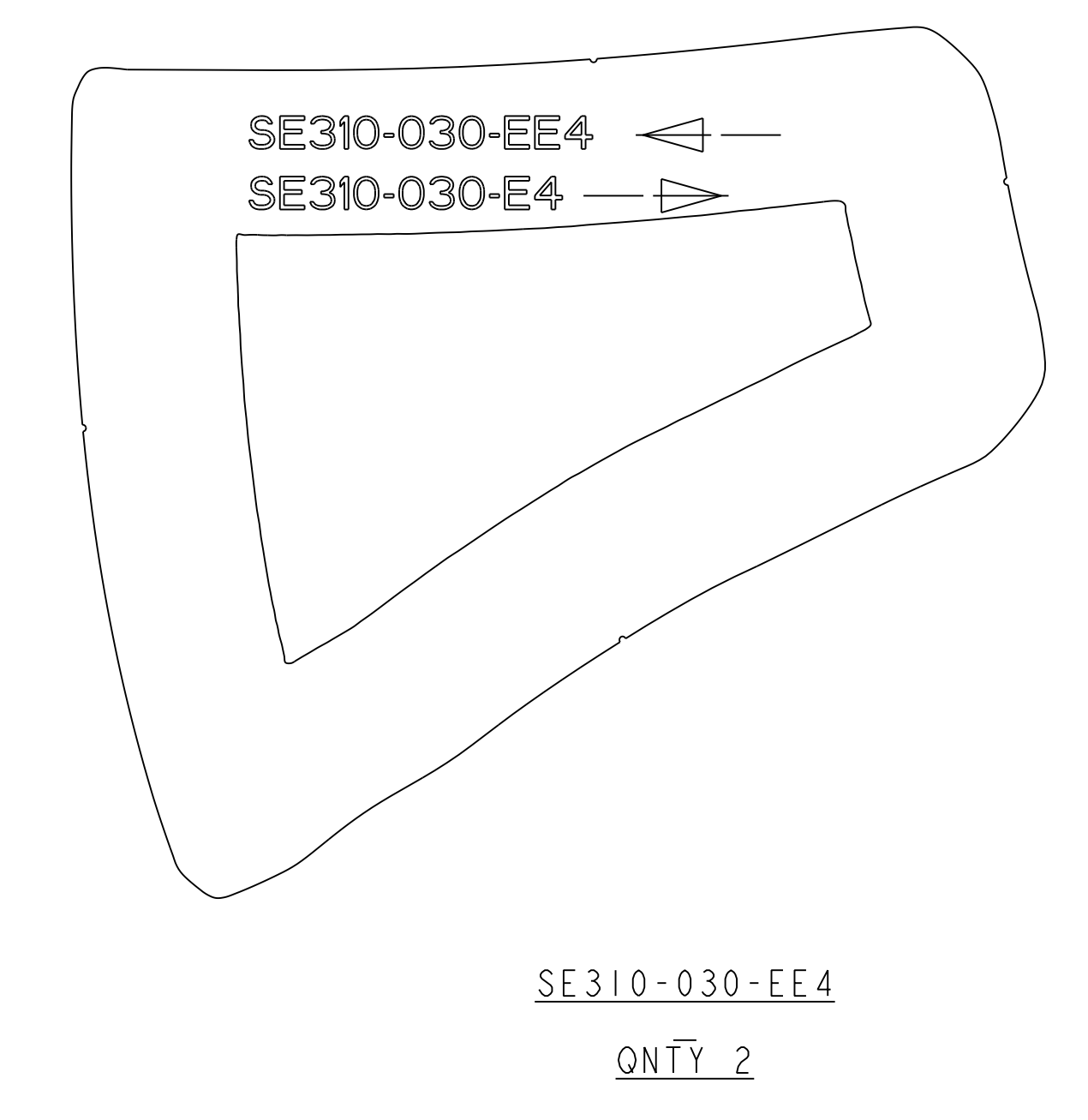
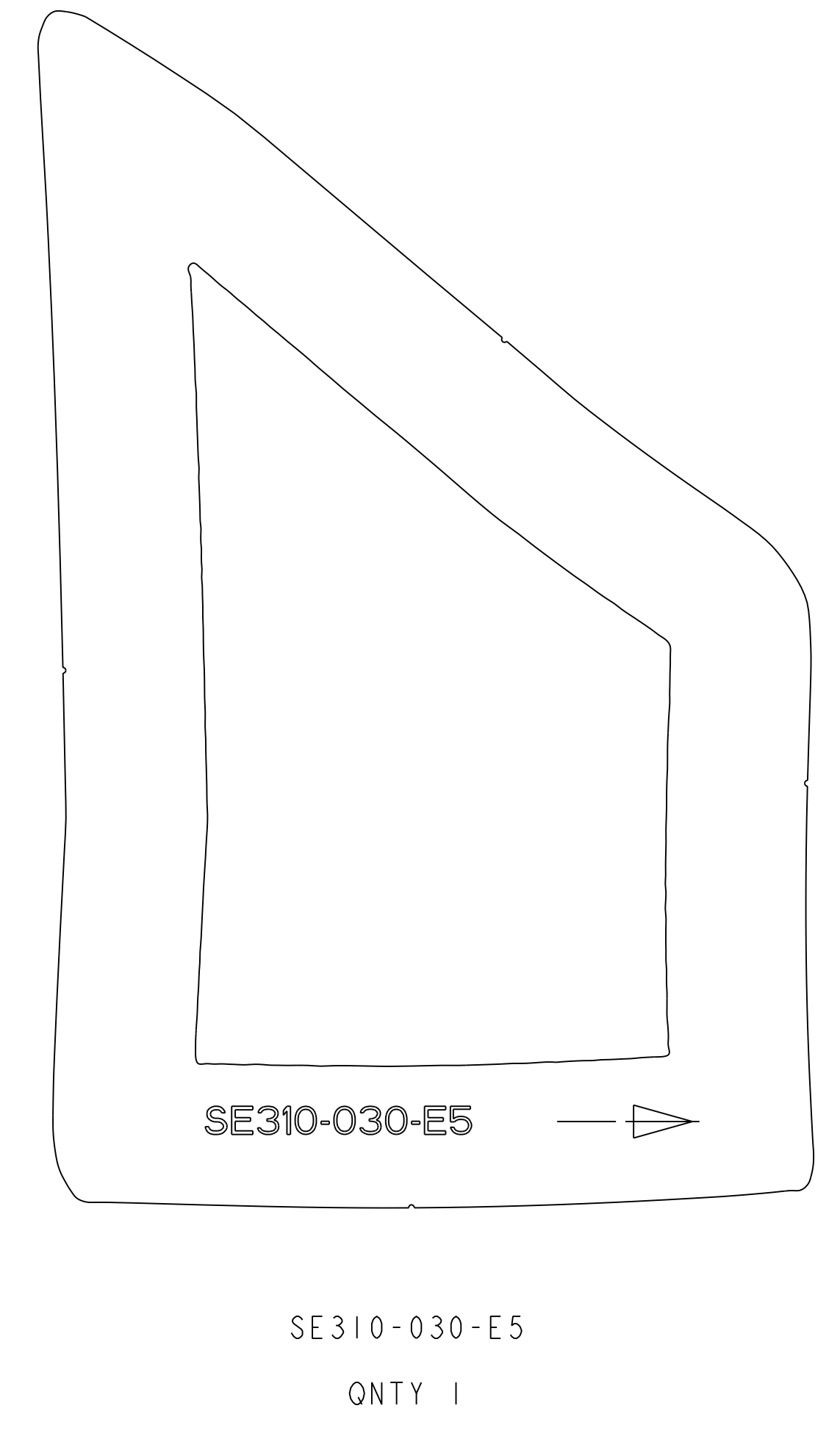
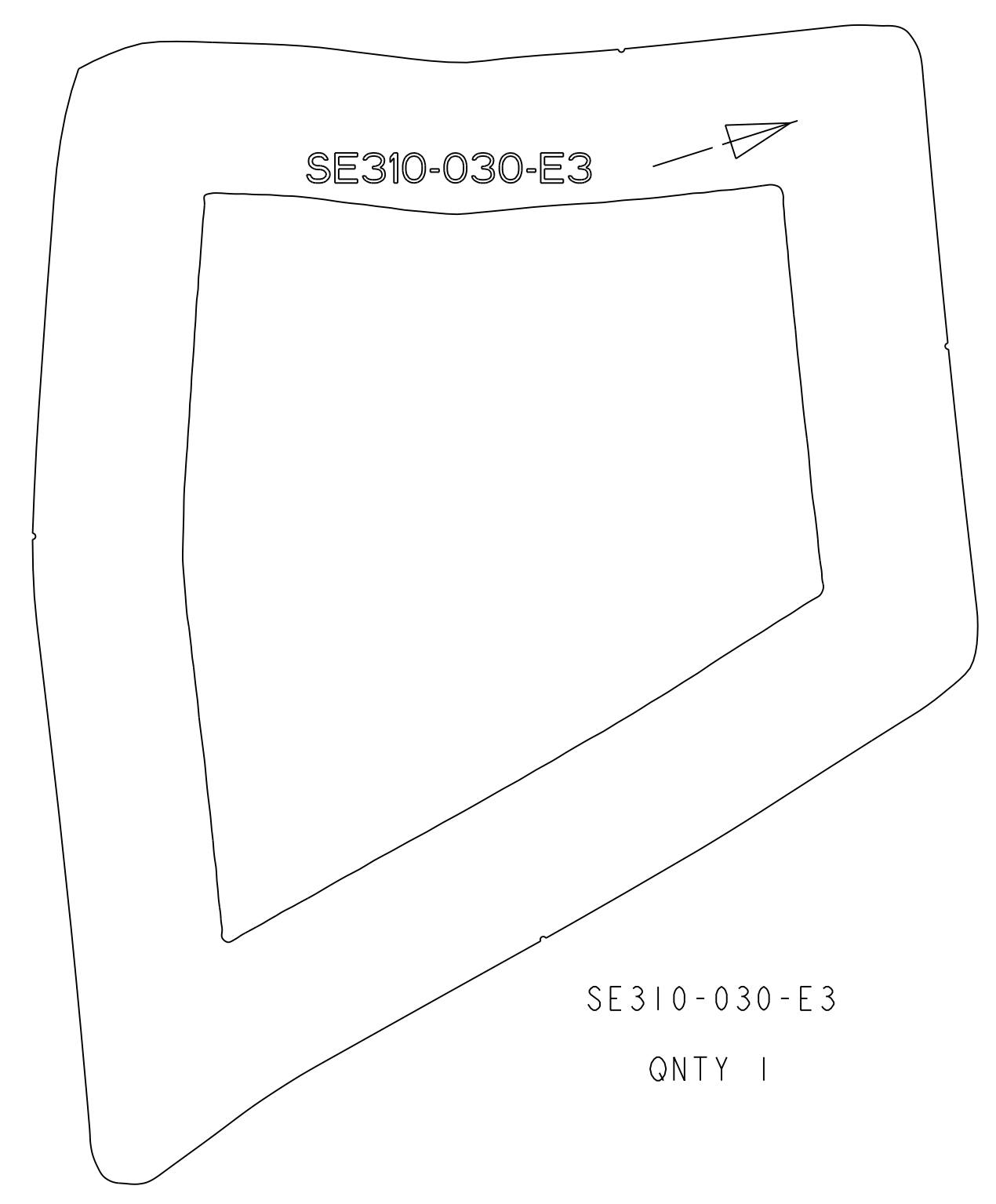
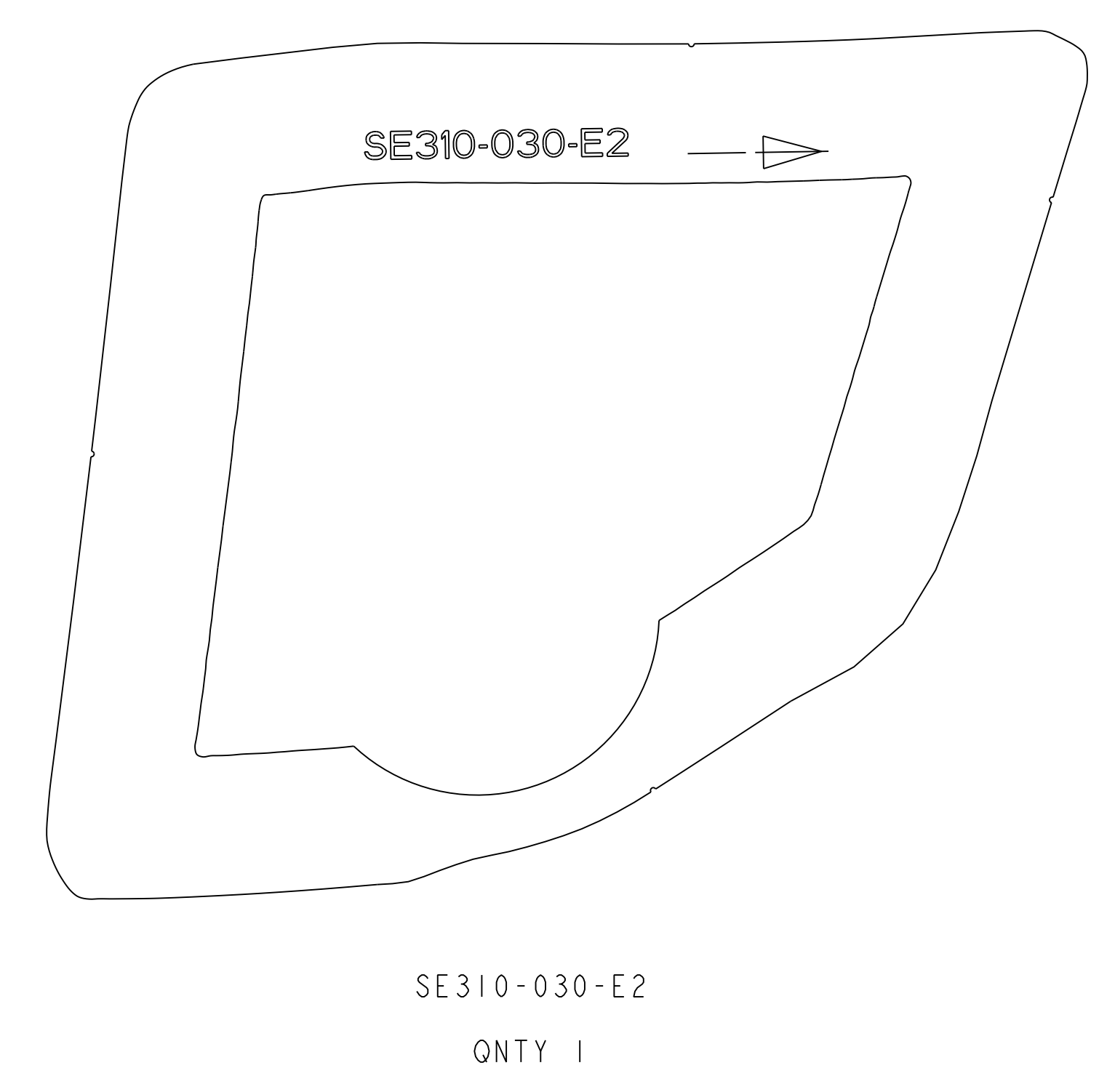
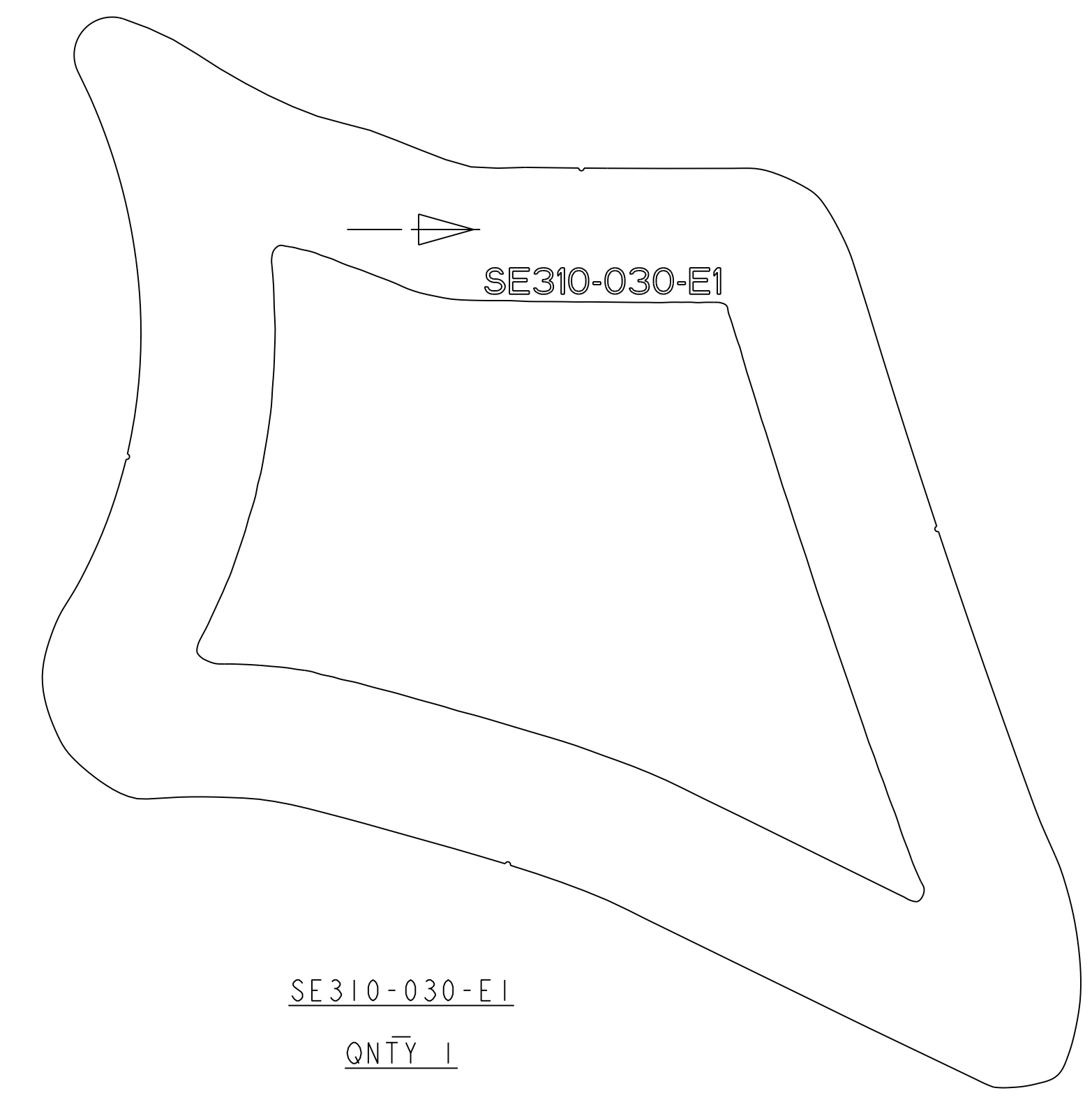

RELEASE LEVEL:  
DWG VERSION NO:

WEIGHT  
\*\*\* lbs

MODEL NAME  
SE310-030-E1

WELDING  
ENGINEER

PART NO.	DRAWING NO	NOMENCLATURE OR DESCRIPTION	MATERIAL	QTY RECD	SEE NOTES
PARTS LIST					
COMPUTER GENERATED DRAWING DRAWING CHANGES NOT PERMITTED	CENTRAL FILES: UNLESS OTHERWISE SPECIFIED	PRINCETON PLASMA PHYSICS LABORATORY PRINCETON UNIVERSITY NATIONAL COMPACT STELLARATOR EXPERIMENT			
Pro E	DIMENSIONS ARE IN INCHES MACHINE SURFACES BREAK SHARP EDGES .005/.020	DIAGNOSTICS MAGNETIC DIAGNOSTICS MAGNETIC LOOPS SERIES "E"			
DO NOT VERIFY INFORMATION BY SCALING DRAWING	TOLERANCES NON-CUMULATIVE	DSN: T. BROWN	1/12/06	DRAWING NO:	
NEXT ASSEMBLY	DECIMAL-INCH FRACTIONS	CHK: J. RUSHINSKI	1/12/06	SE310-030-A Q	
	.XX +/- .030 .XXX +/- .005 ANGULAR +/- .0°-15'	ENGR: G. LABIK	1/12/06	SHEET 3 OF 15	
		SUPV: J. SIEGEL	1/12/06	REV 0	

NCSX-SE310-030-A-Q

NO.	REVISION	BY	CH	SUP	APPROVED	DATE

FOR NOTES SEE SHEET 1

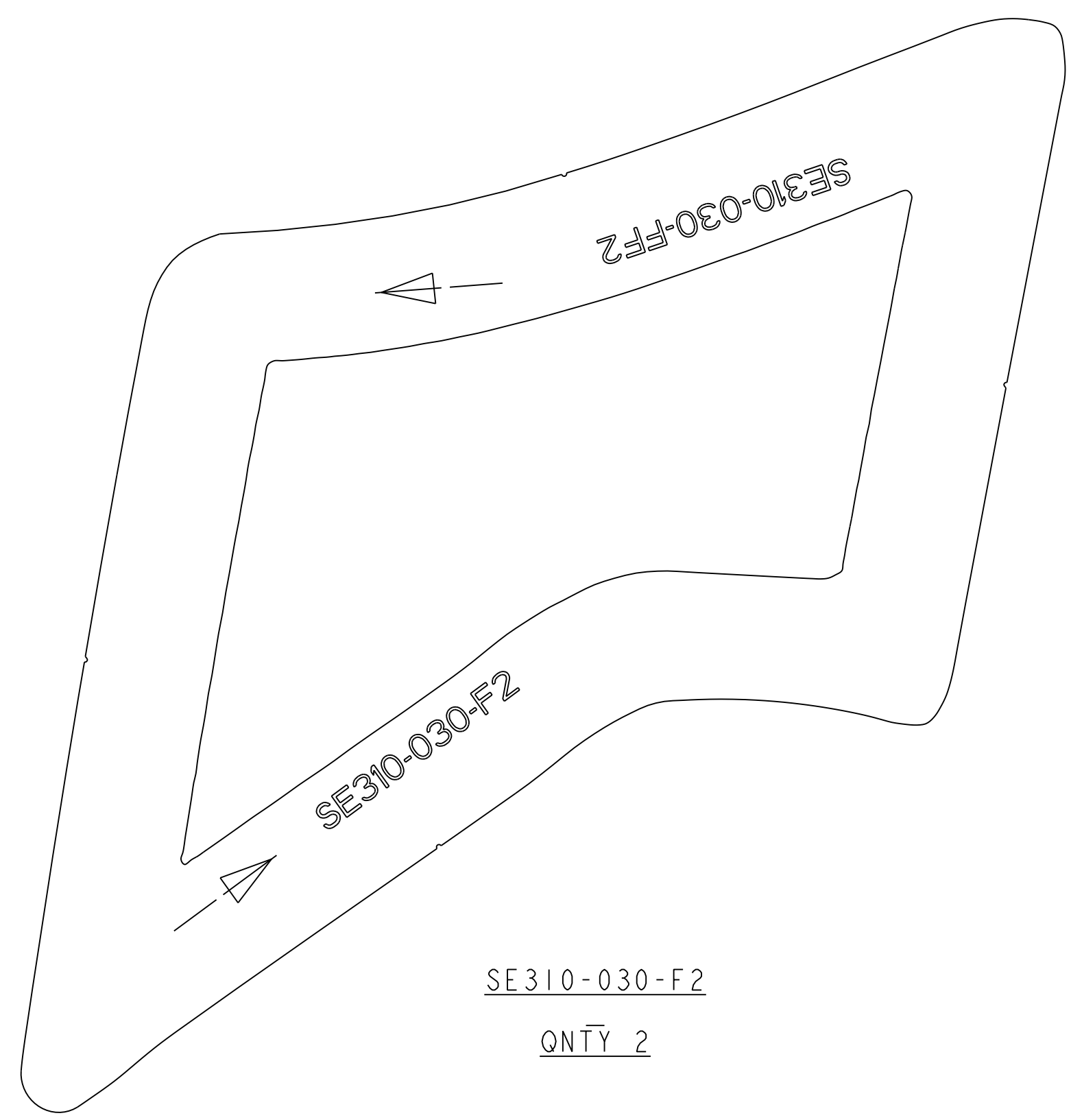

SE310-030-F2  
QNTY 2

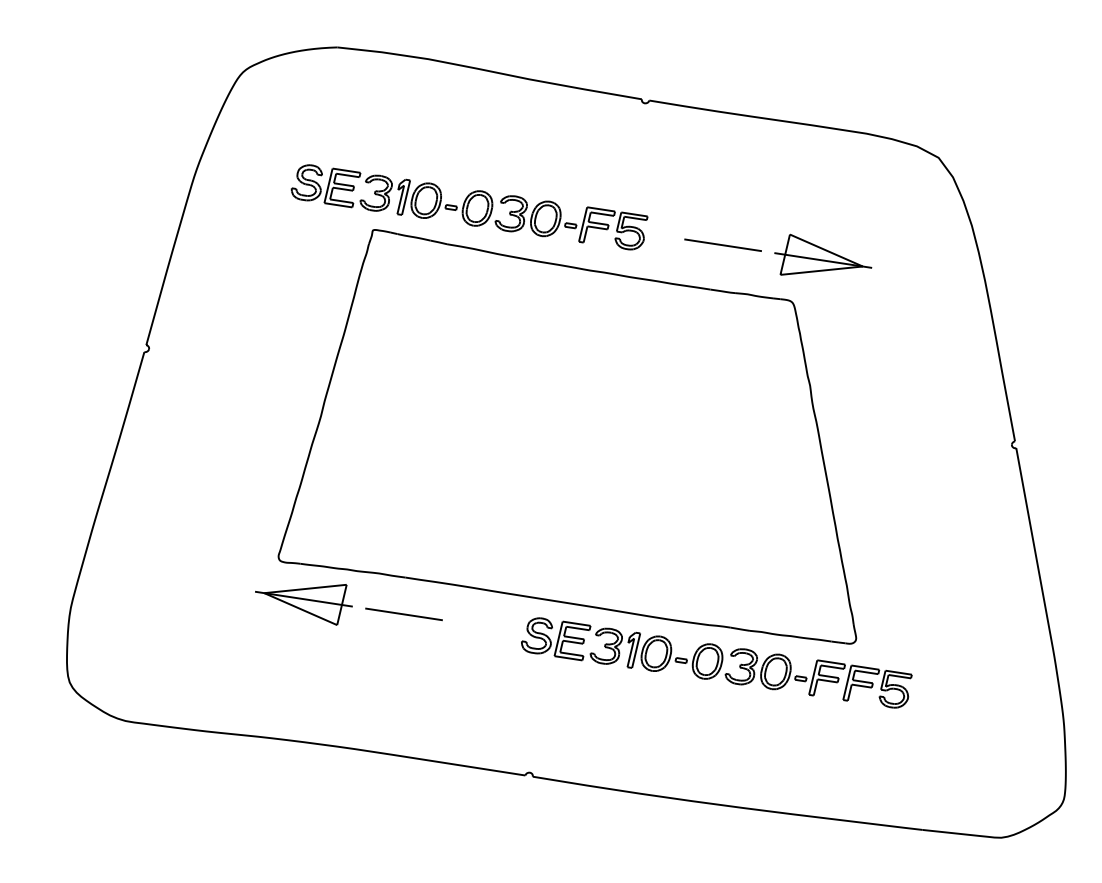

SE310-030-F5  
QNTY 1

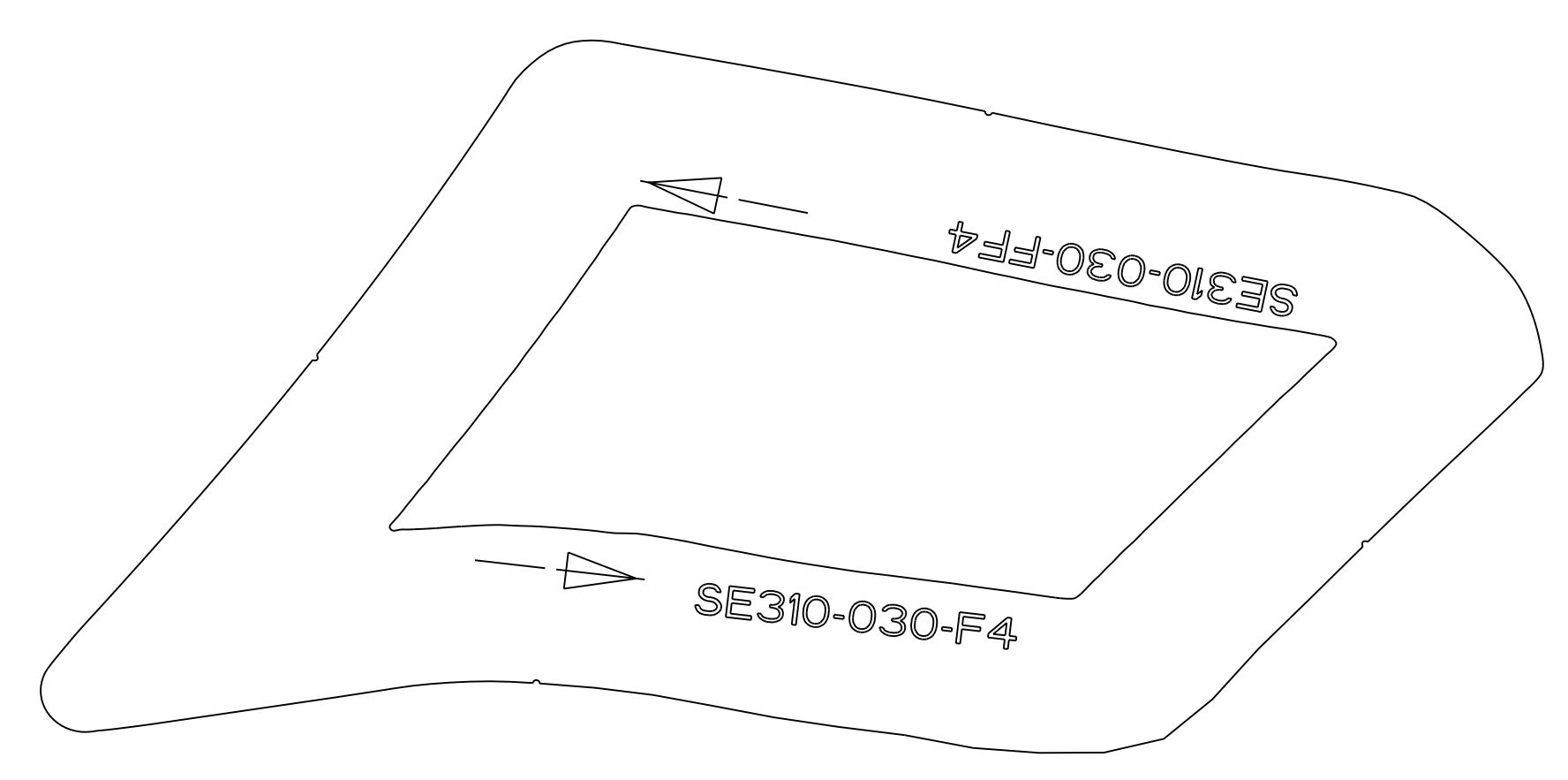

SE310-030-F4  
QNTY 2

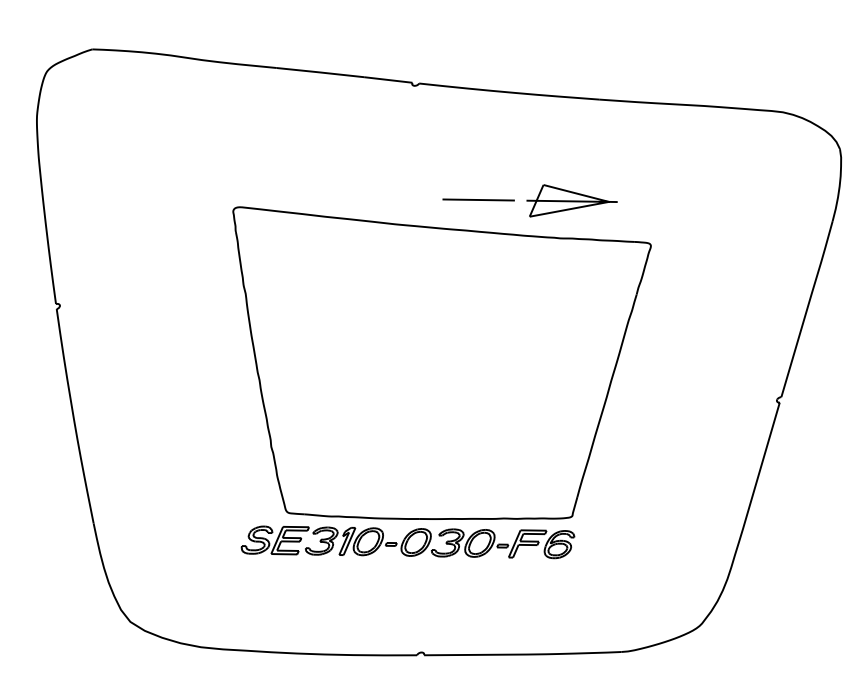

SE310-030-F6  
QNTY 1

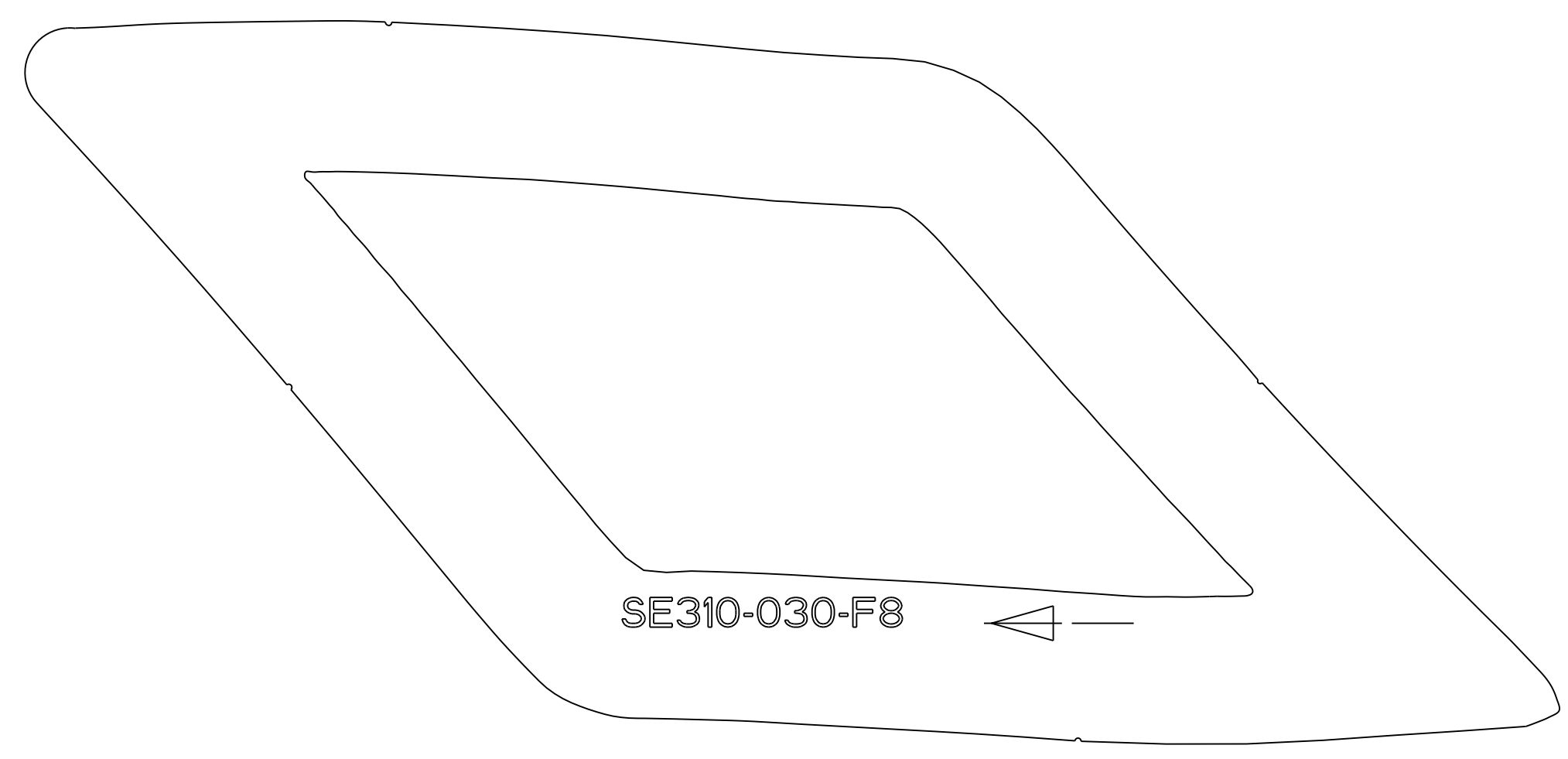

SE310-030-F8  
QNTY 1

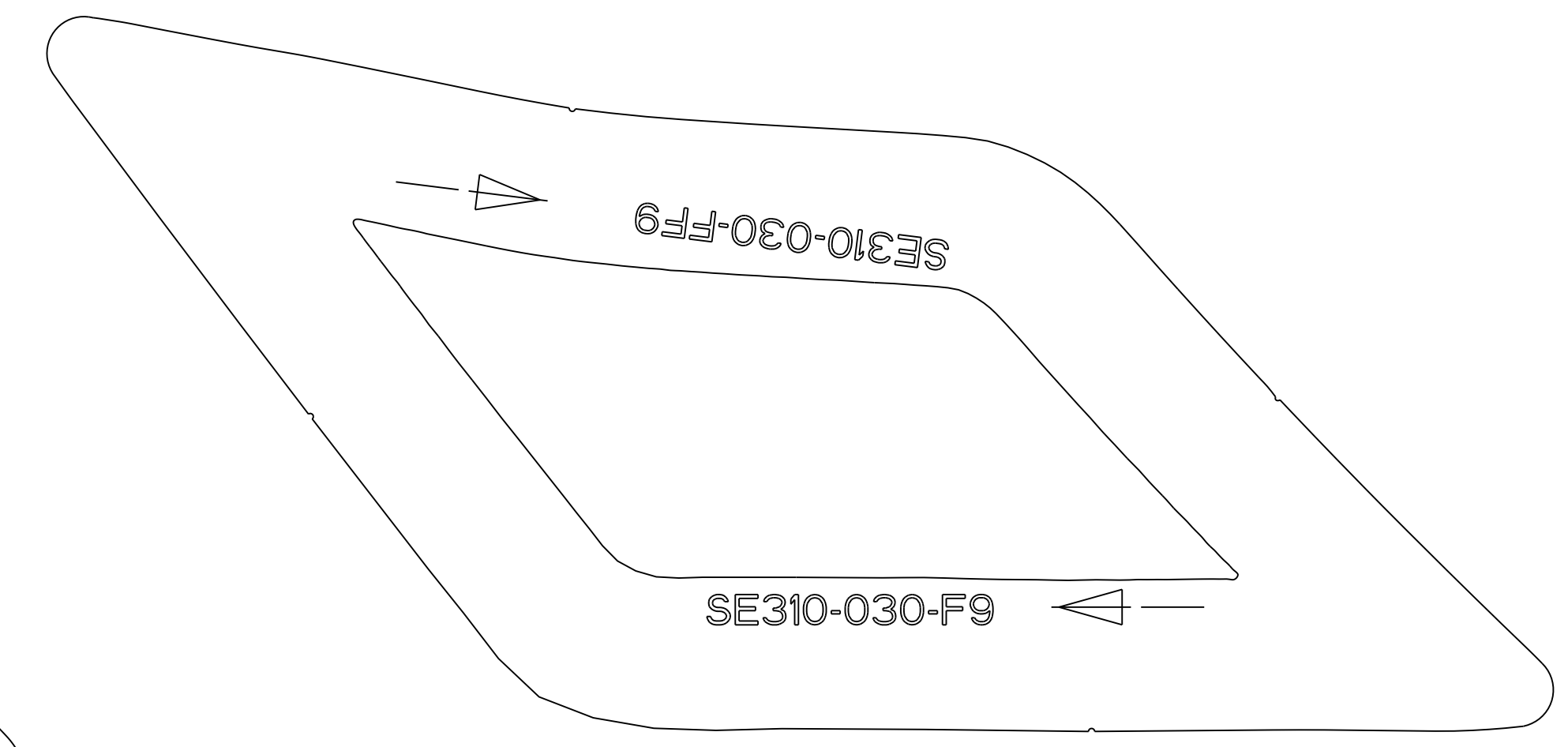

SE310-030-F9  
QNTY 2

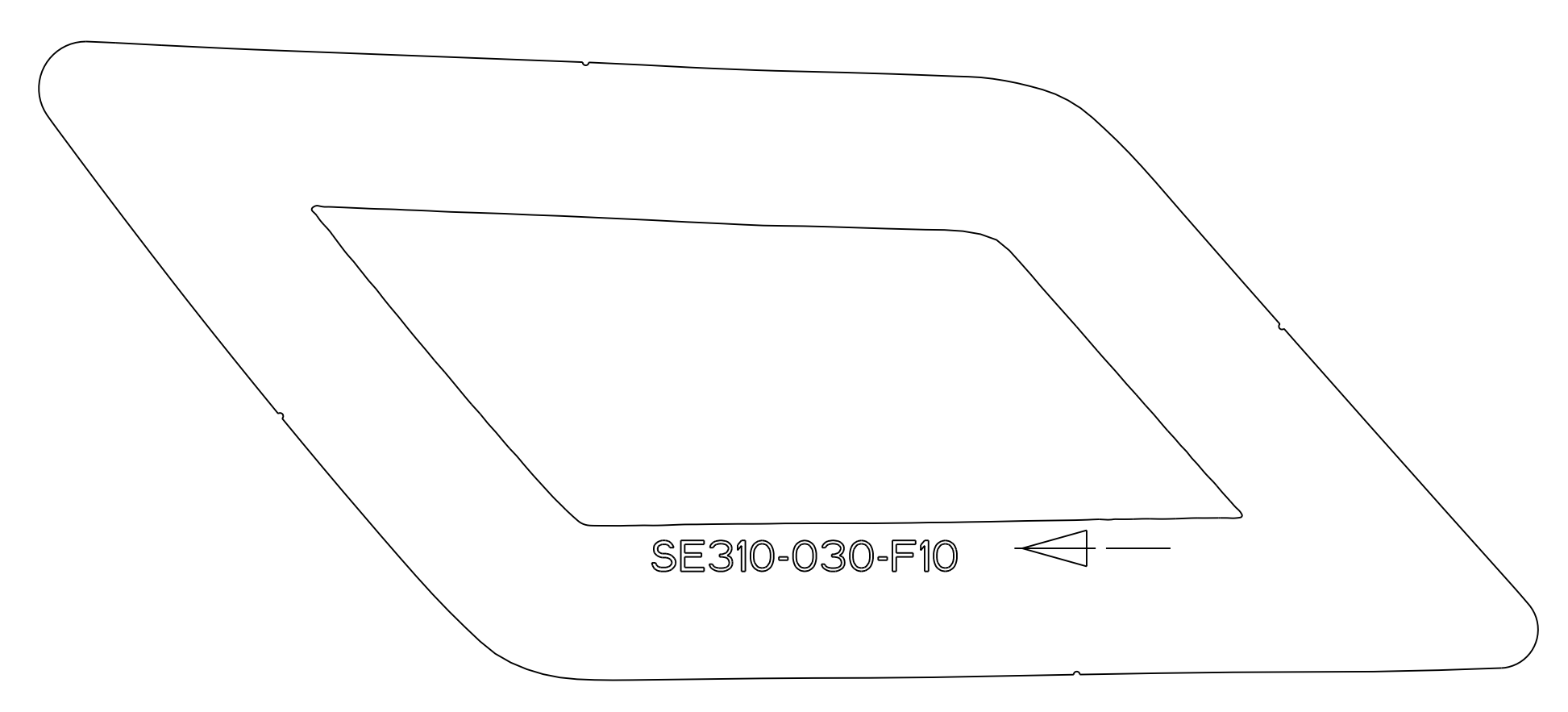

SE310-030-F10  
QNTY 1

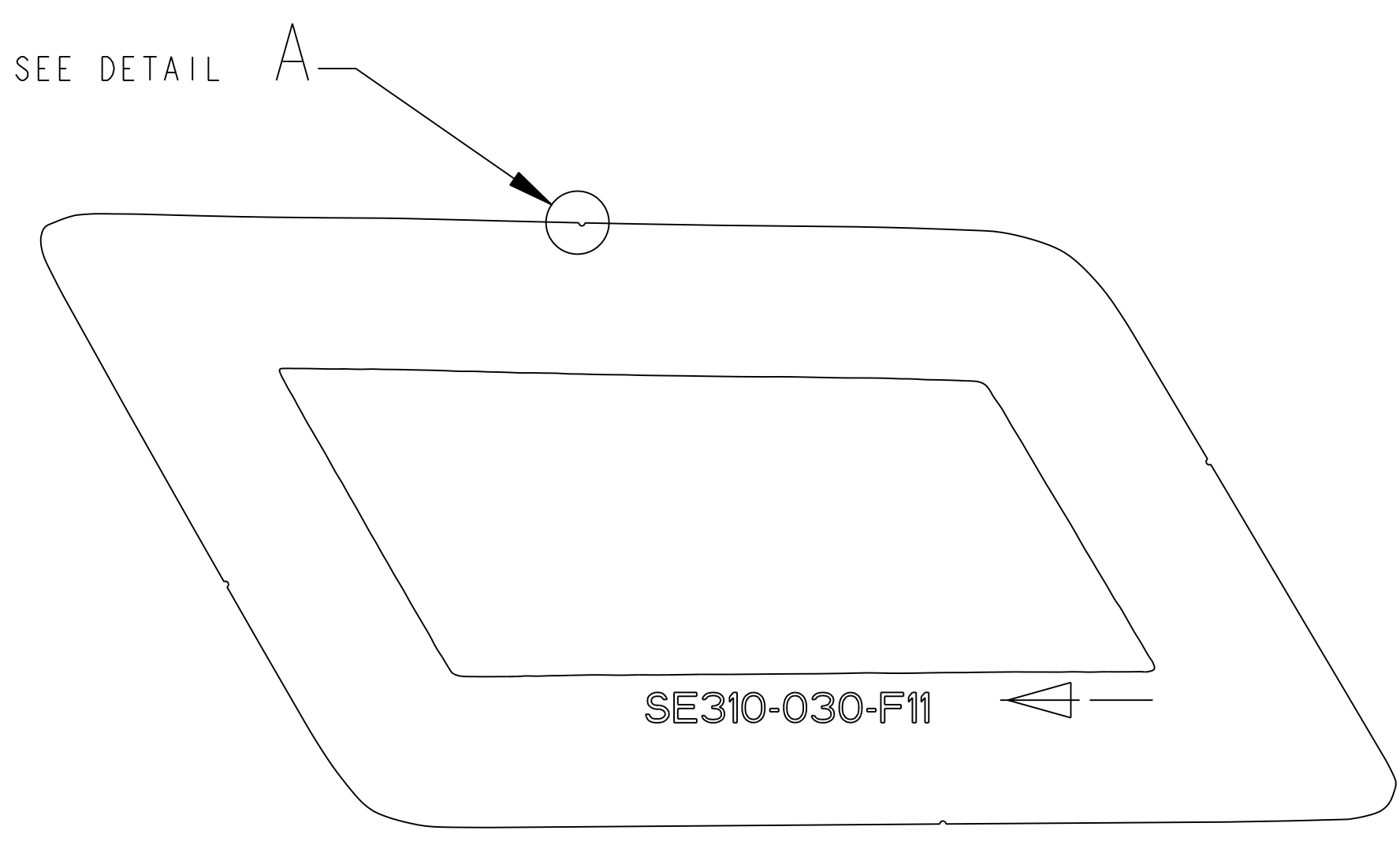

SE310-030-F11  
QNTY 1

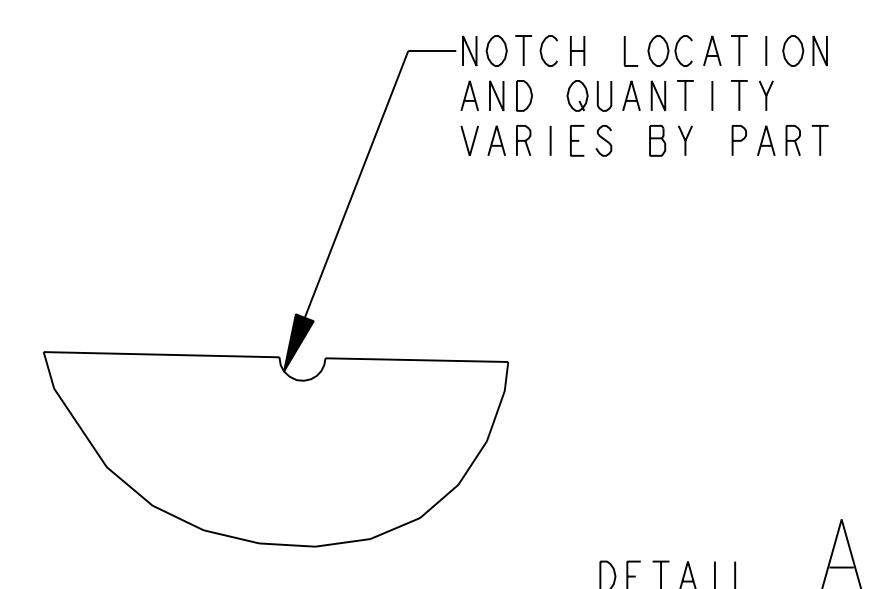

DETAIL A  
SCALE 6.000

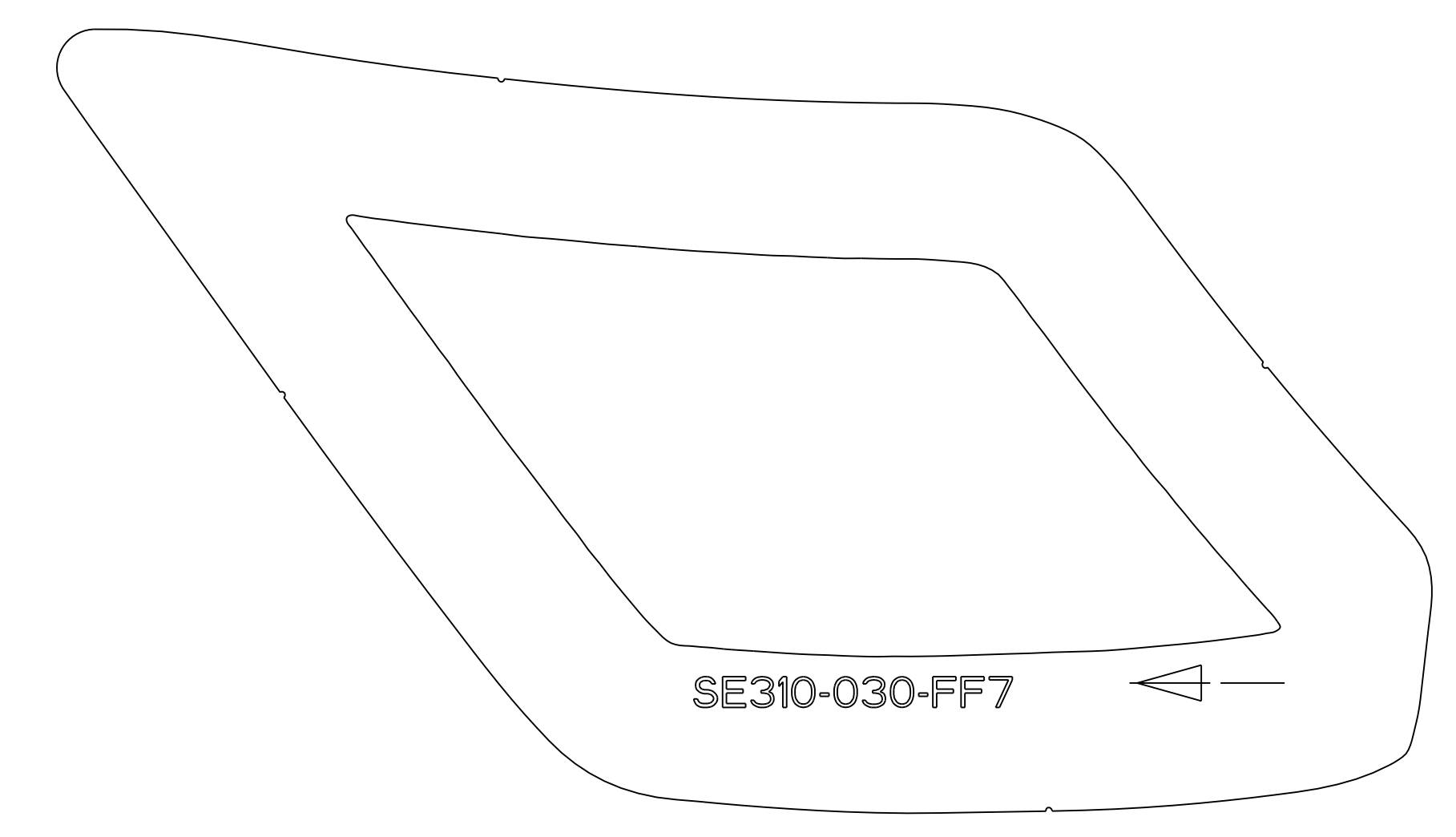

SE310-030-FF7  
QNTY 1

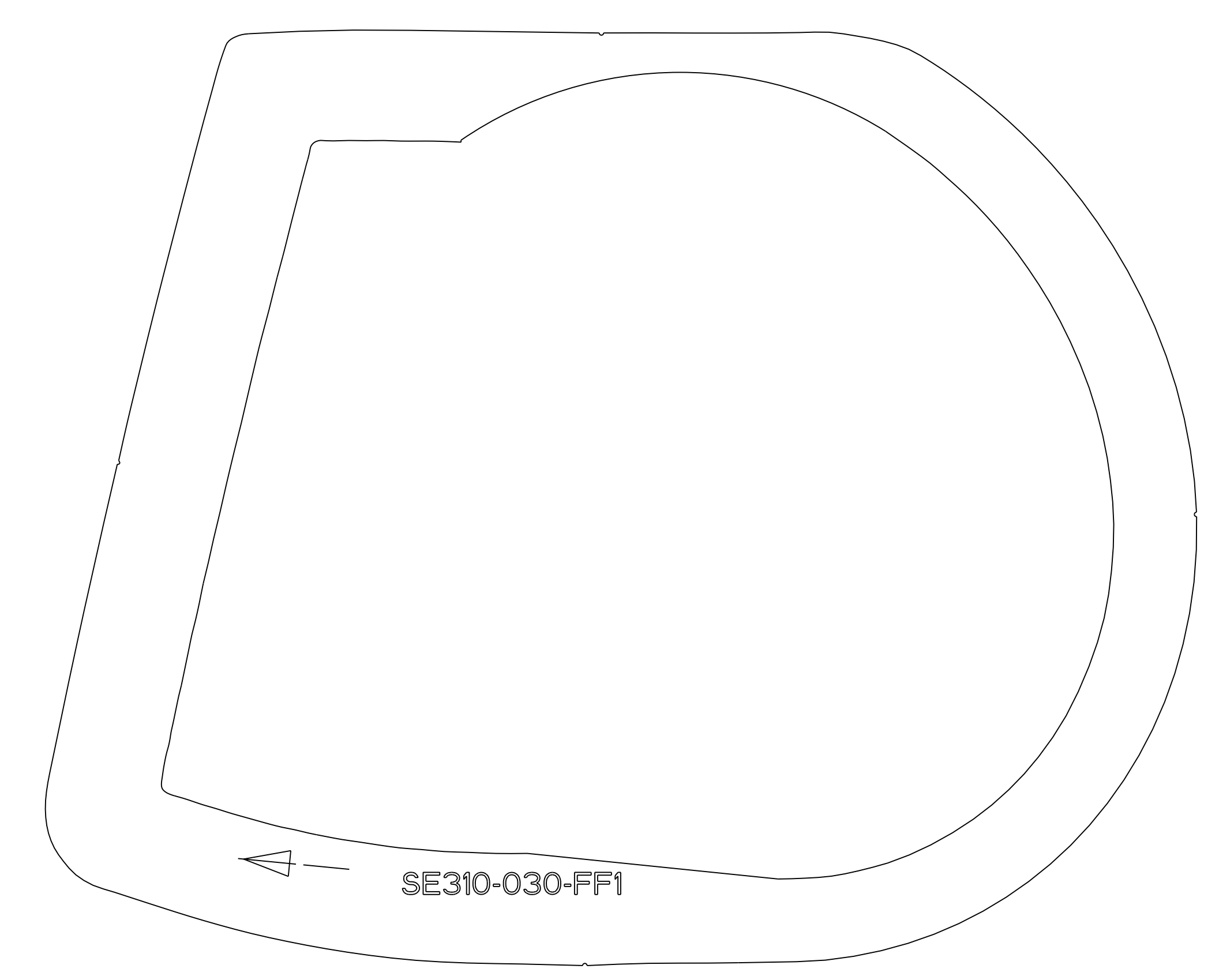

SE310-030-FF1  
QNTY 1

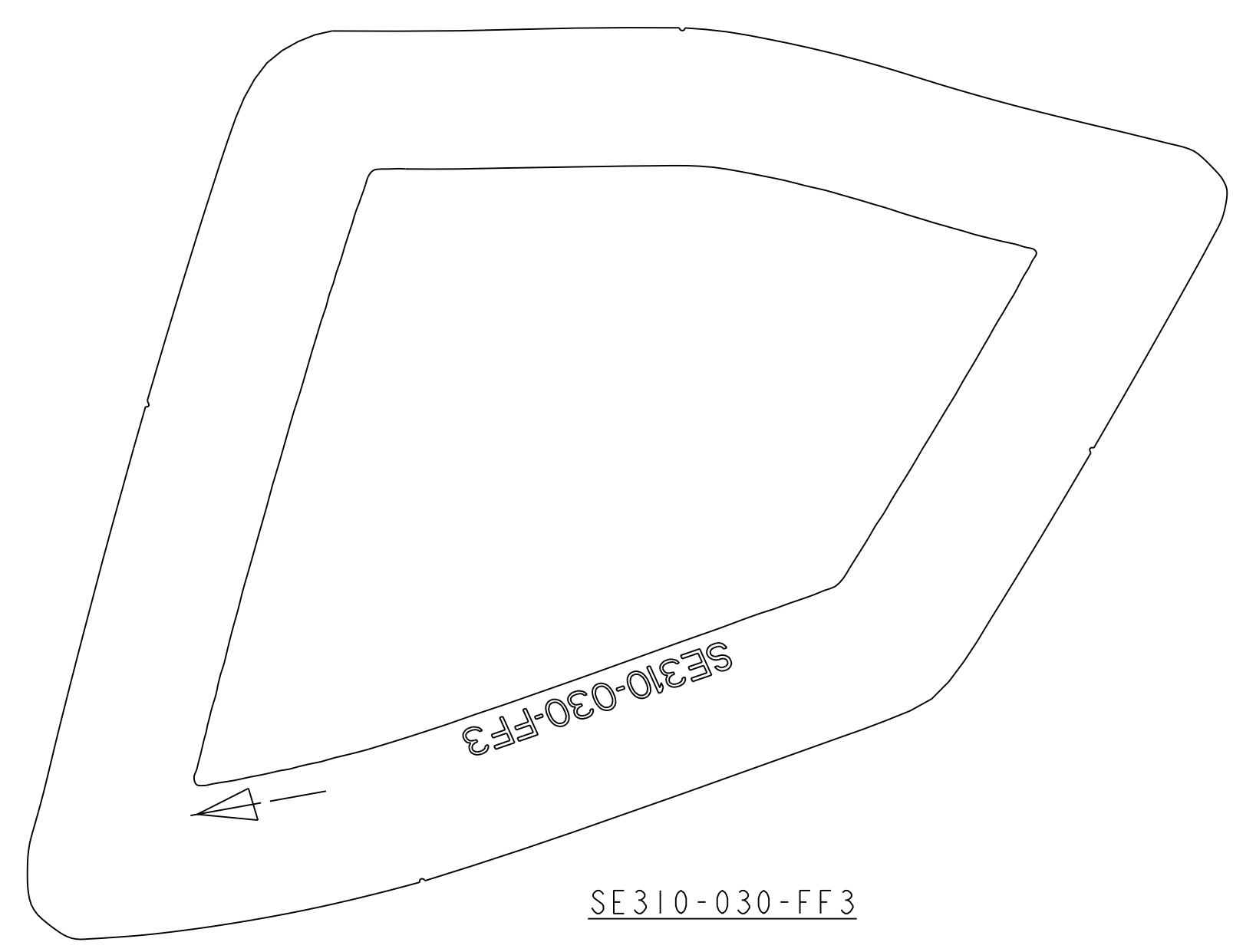

SE310-030-FF3  
QNTY 1

RELEASE LEVEL:  
DWG VERSION NO:

WEIGHT	*** lbs
MODEL NAME	SE310-030-HH7
WELDING ENGINEER	

PART NO.	DRAWING NO.	NOMENCLATURE OR DESCRIPTION	MATERIAL	QTY REOD
PARTS LIST				
COMPUTER GENERATED DRAWING CHANGES NOT PERMITTED				
CENTRAL FILES: PRINCETON PLASMA PHYSICS LABORATORY				
UNLESS OTHERWISE SPECIFIED NATIONAL COMPACT STELLARATOR EXPERIMENT				
DIMENSIONS ARE IN INCHES MACHINE SURFACES				
BREAK SHARP EDGES .005/.020				
TOLERANCES NON-CUMULATIVE				
DECIMAL-INCH FRACTIONS		DSN: T. BROWN 1/12/06 DRAWING NO:		
NEXT ASSEMBLY		CHK: J. RUSHINSKI 1/12/06		
		ENGR: G. LABIK 1/12/06		
		SUPV: J. SIEGEL 1/12/06		
				SHEET 4 OF 15 REV 0

NCSX-SE310-030-A-Q

NO.	REVISION	BY	CH	SUP	APPROVED	DATE

FOR NOTES SEE SHEET 1

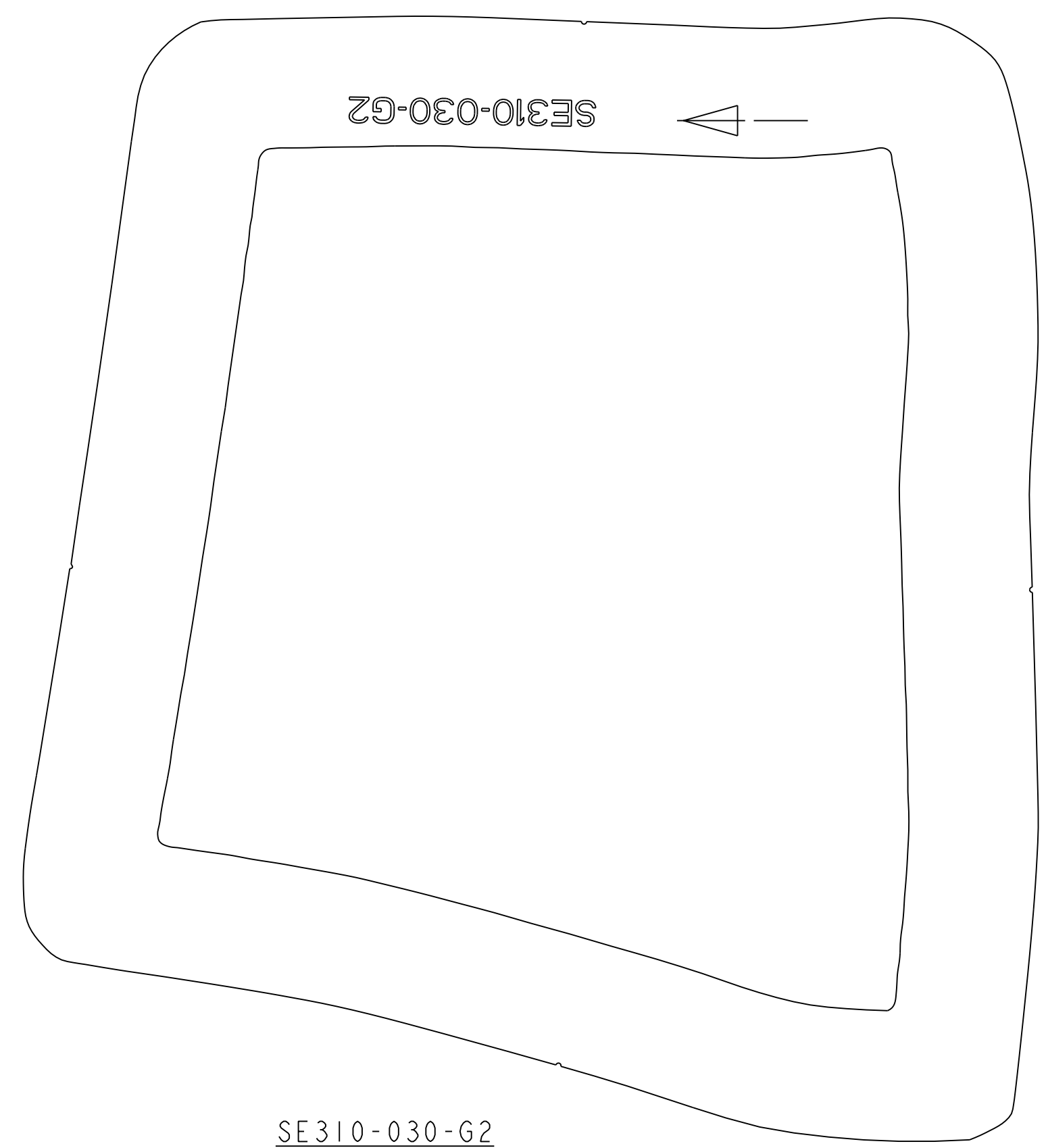

SE310-030-G2  
QNTY 1

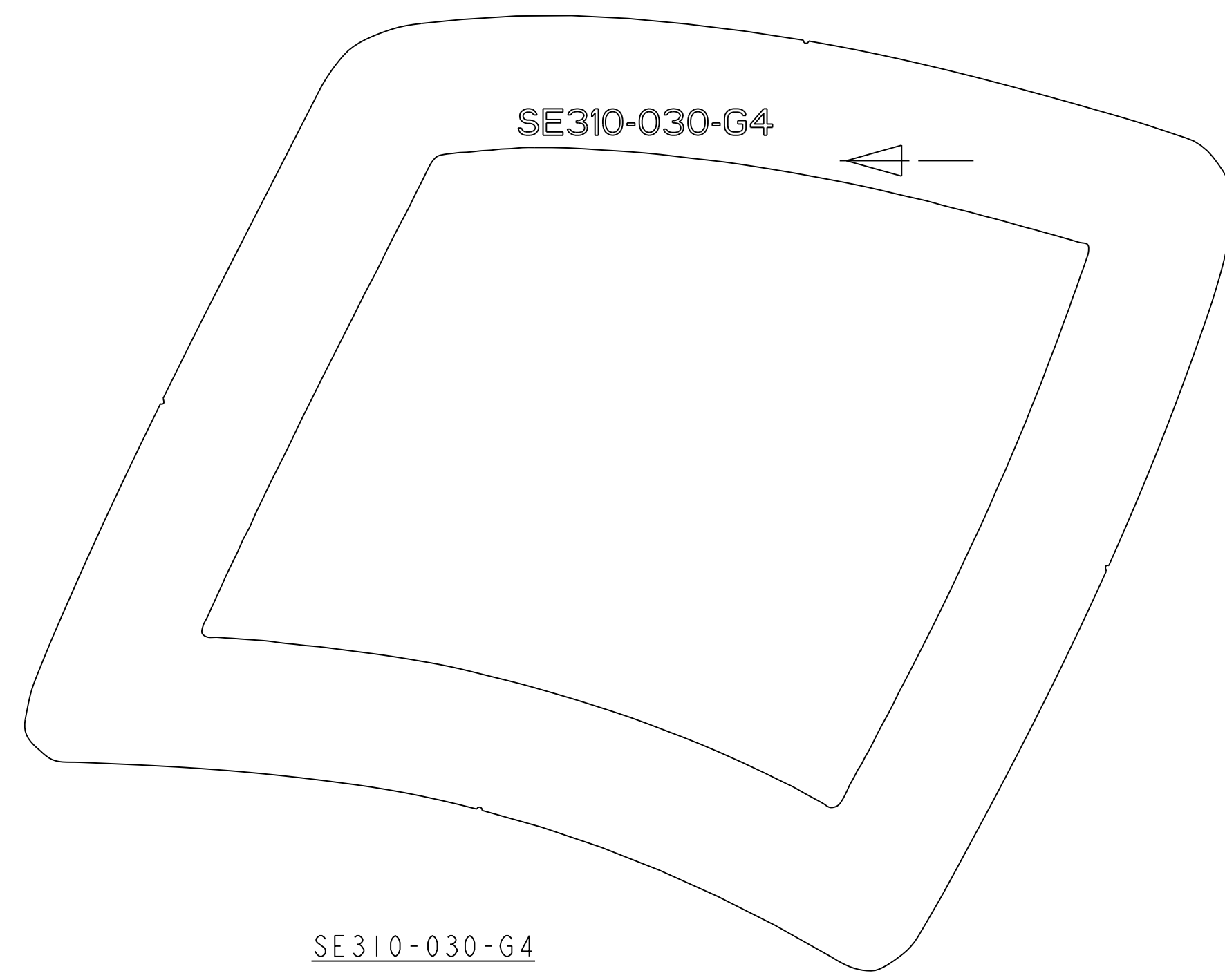

SE310-030-G4  
QNTY 1

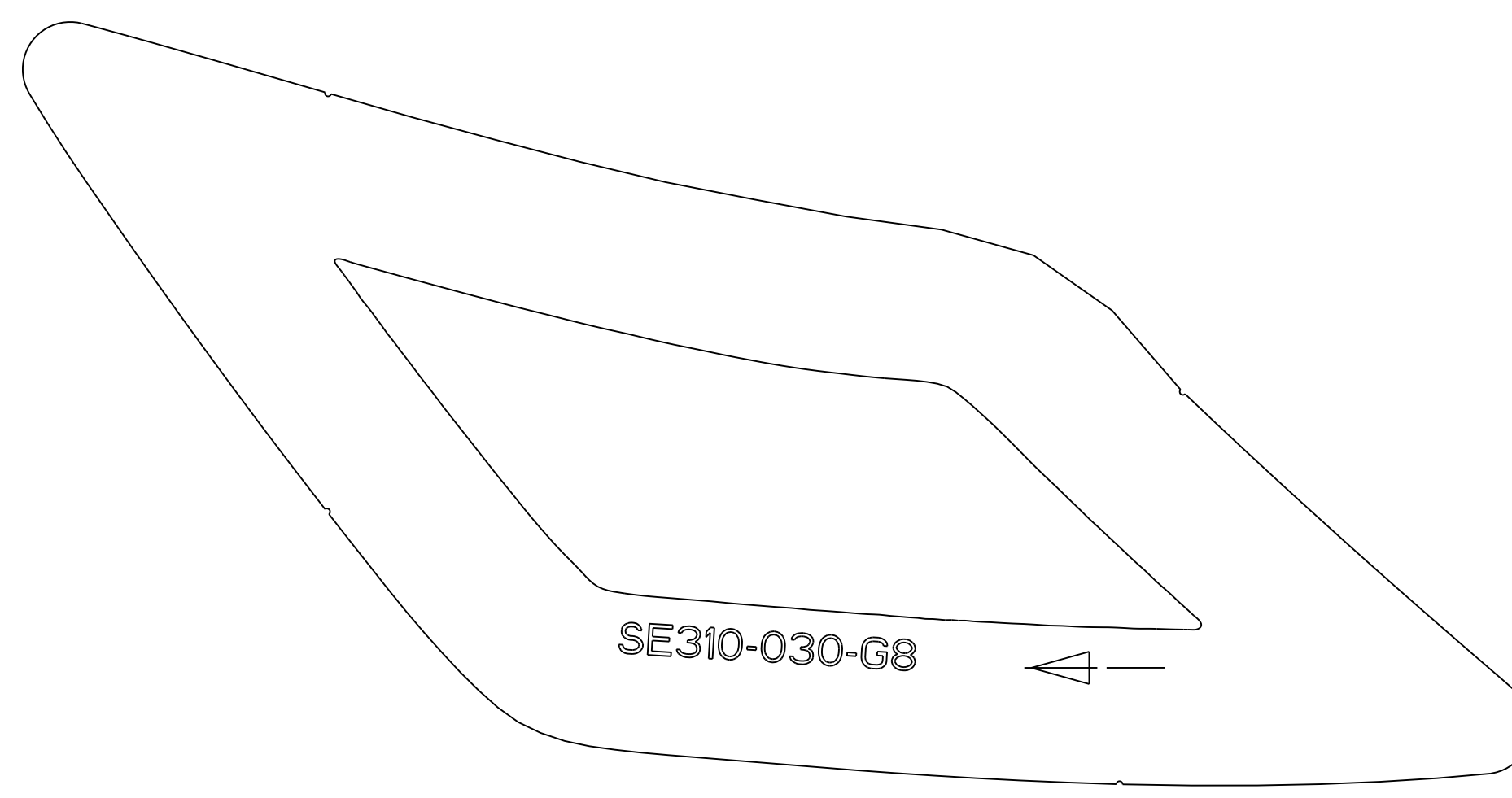

SE310-030-G8  
QNTY 1

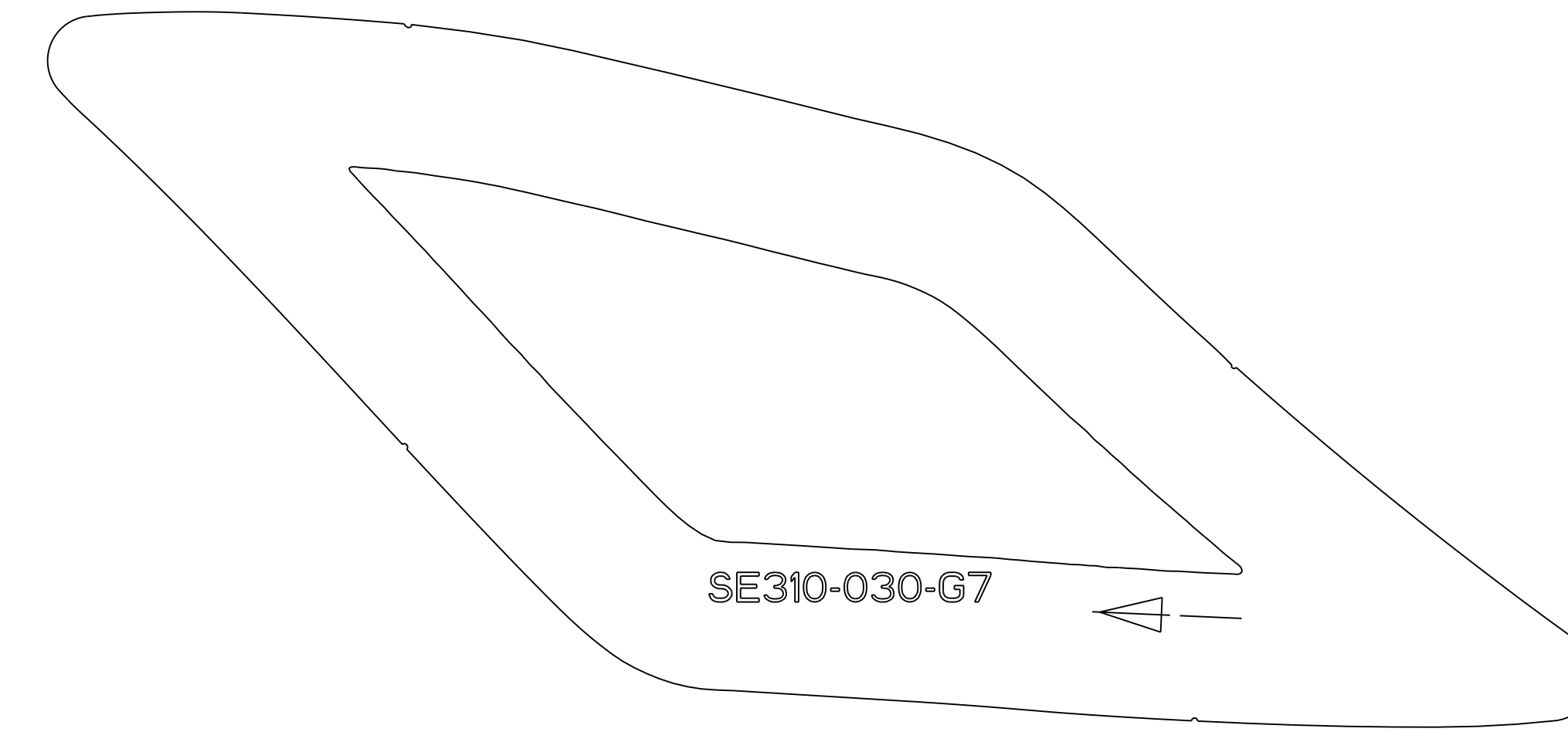

SE310-030-G7  
QNTY 1

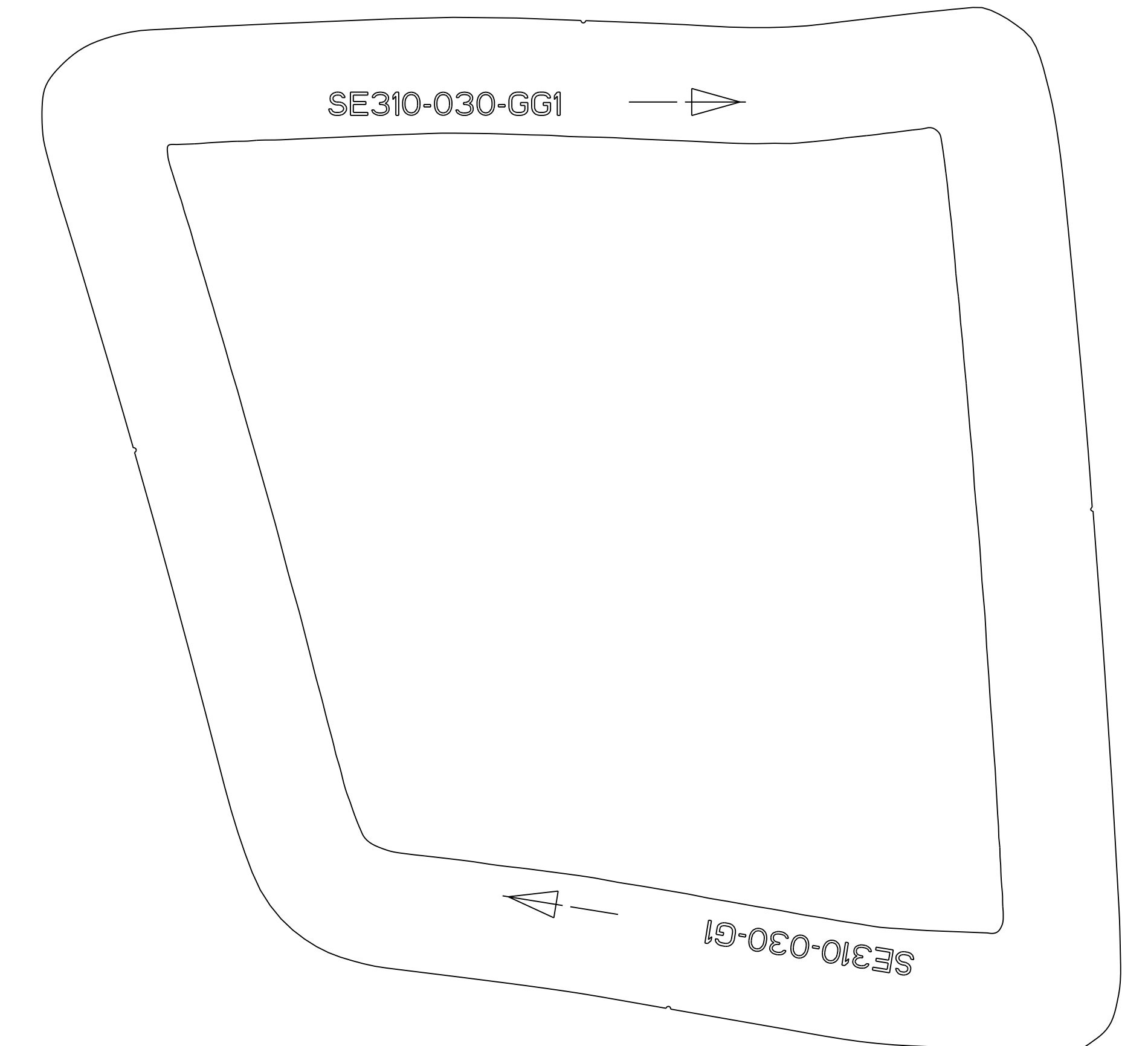

SE310-030-GG1  
QNTY 1

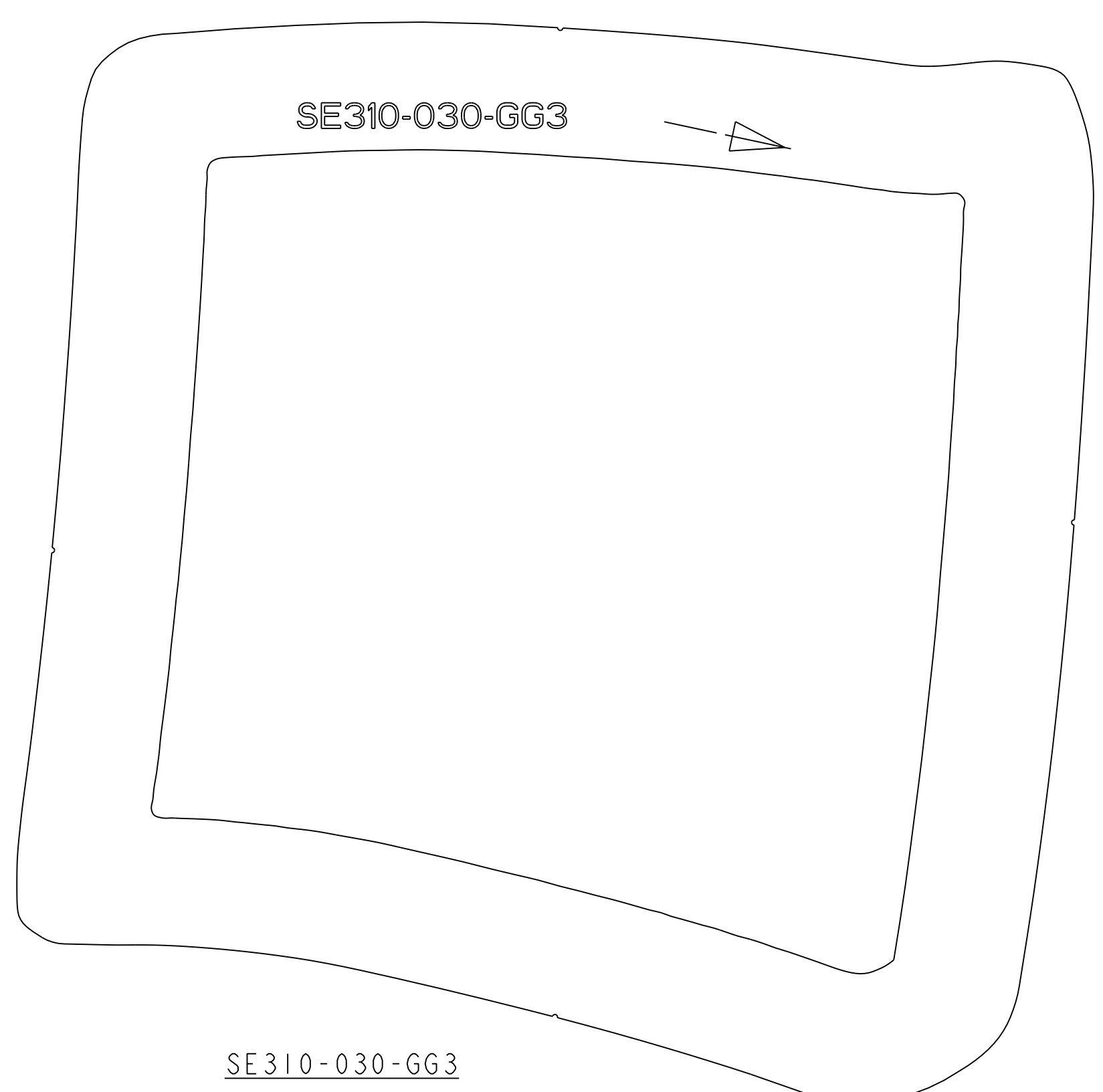

SE310-030-GG3  
QNTY 1

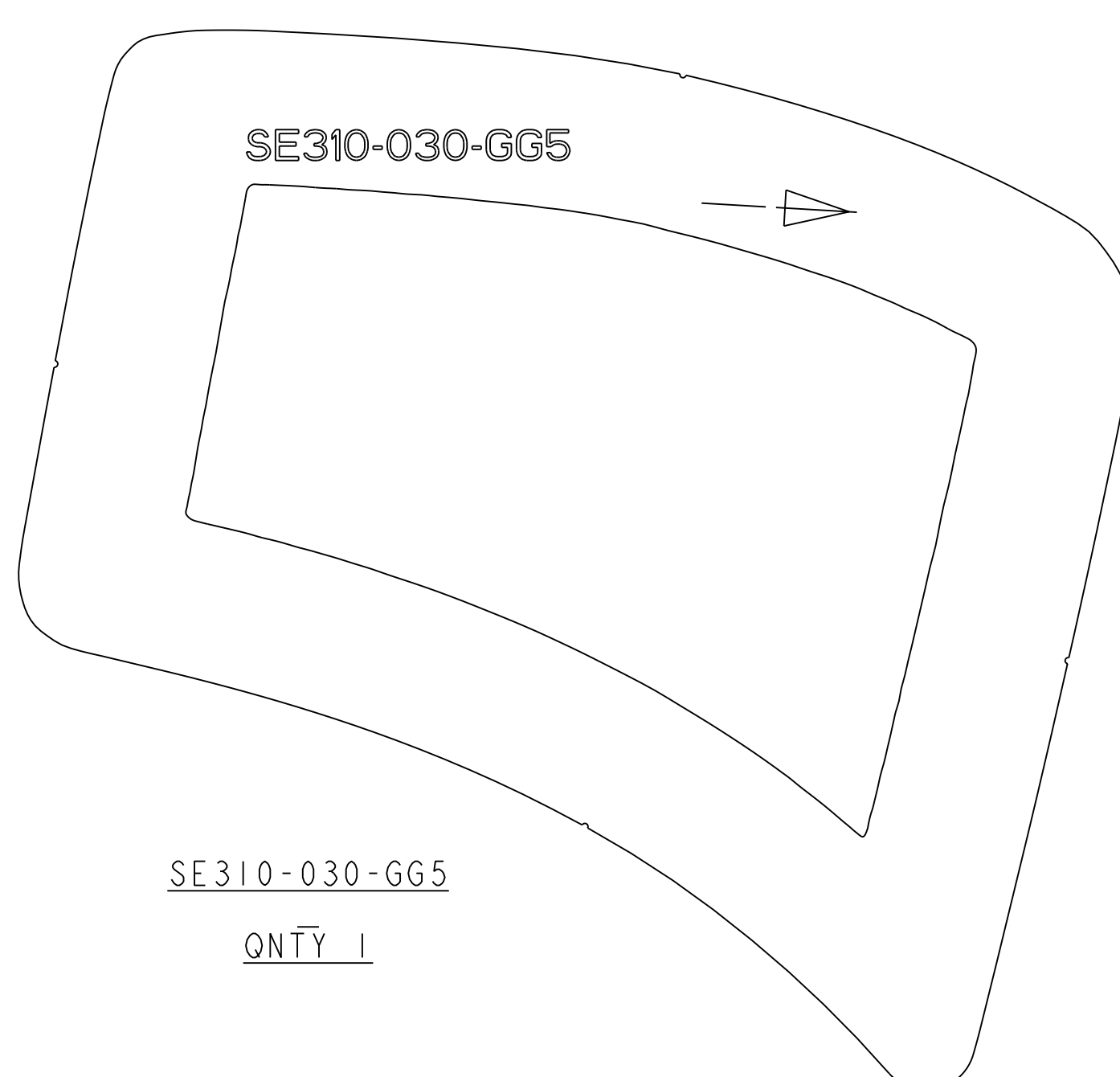

SE310-030-GG5  
QNTY 1



SE310-030-GG6  
QNTY 1

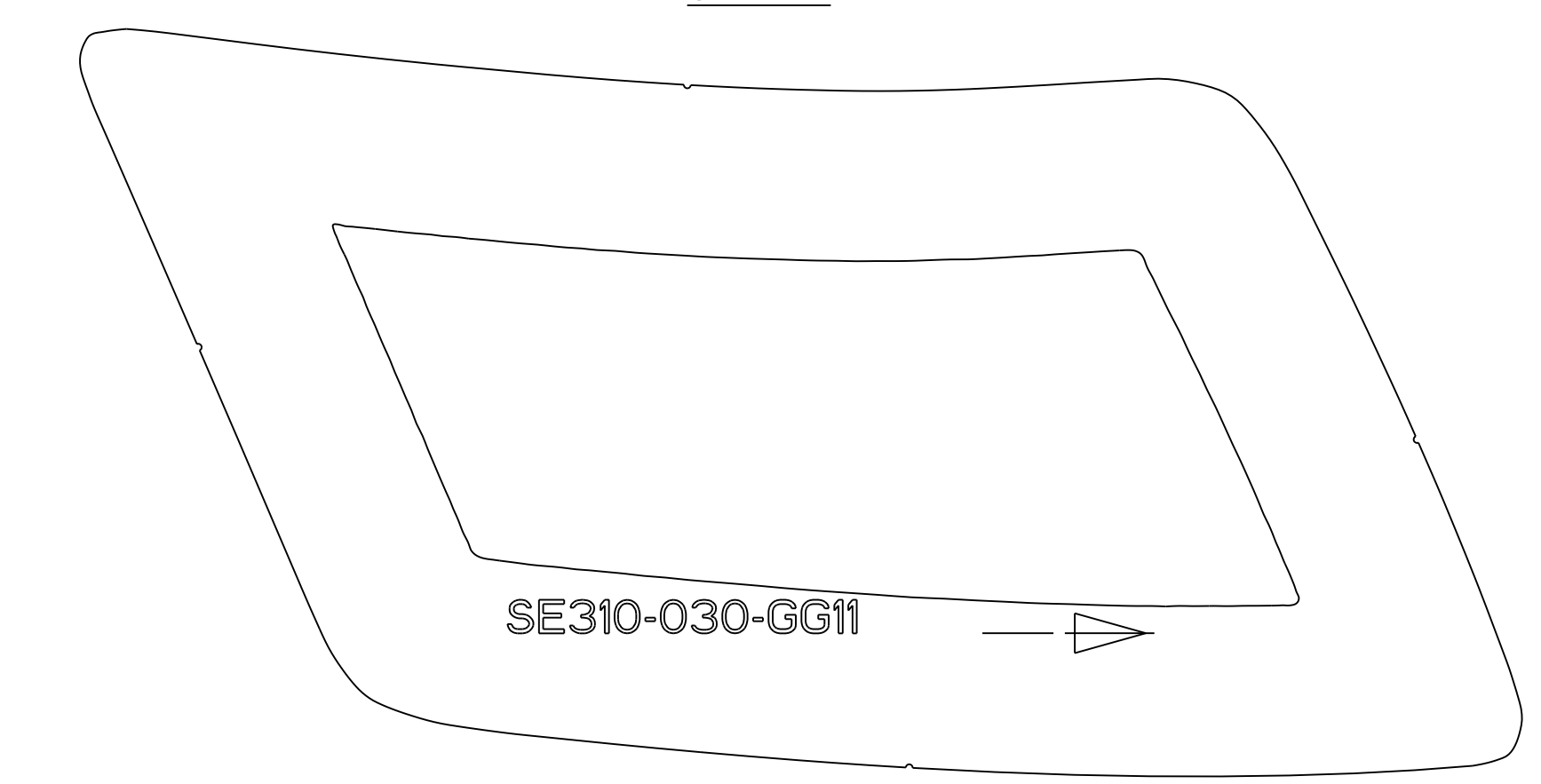

SE310-030-GG11  
QNTY 1

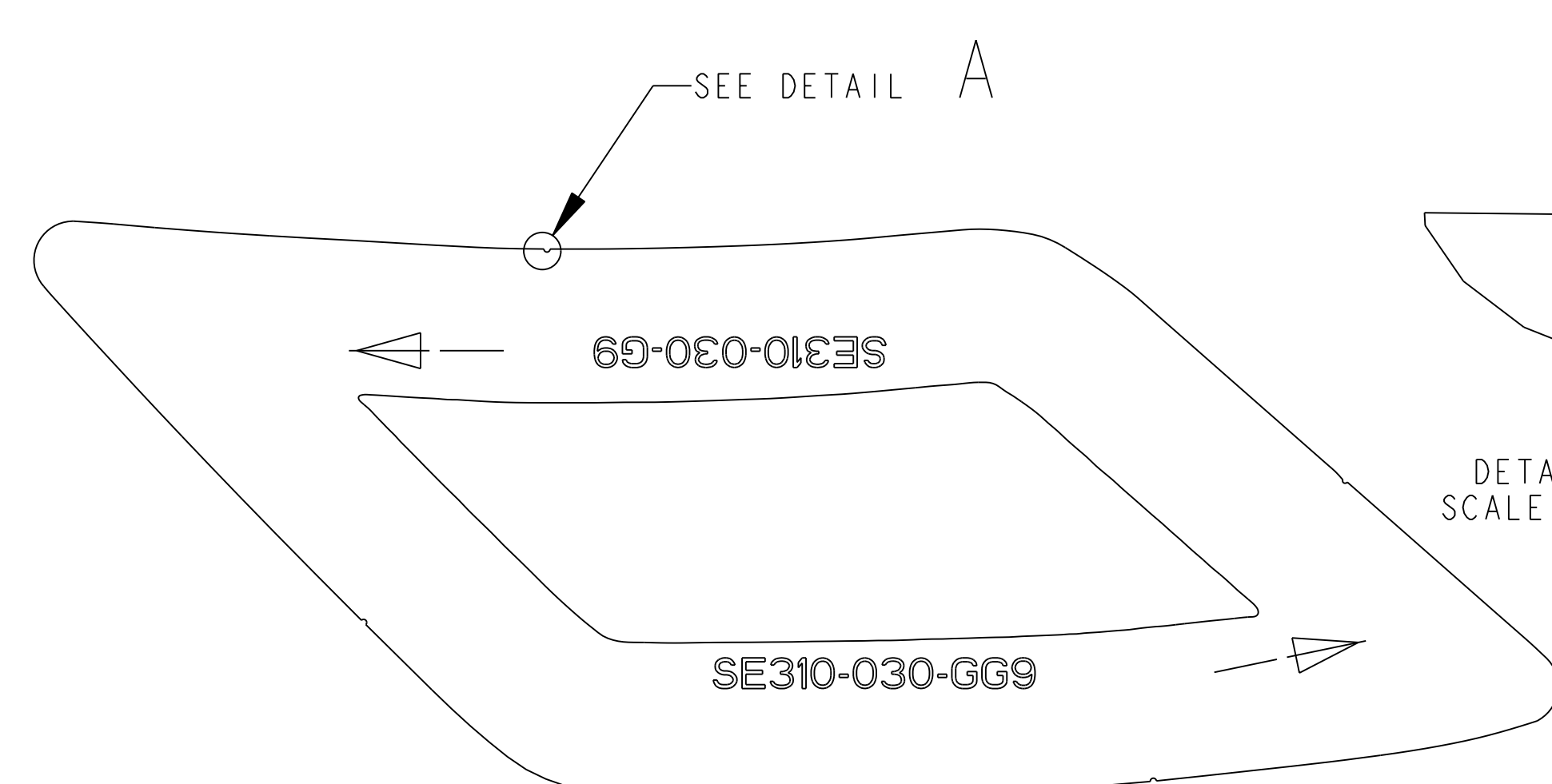

SE310-030-GG9  
QNTY 1

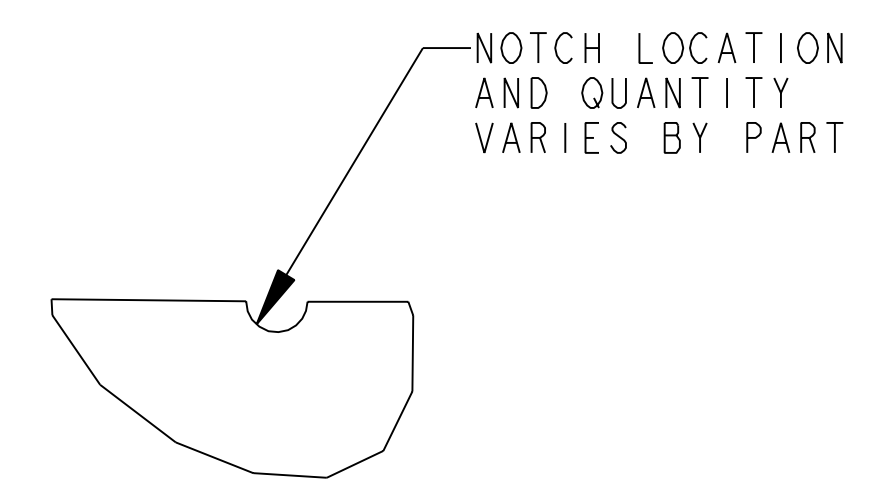

DETAIL A  
SCALE 8.000

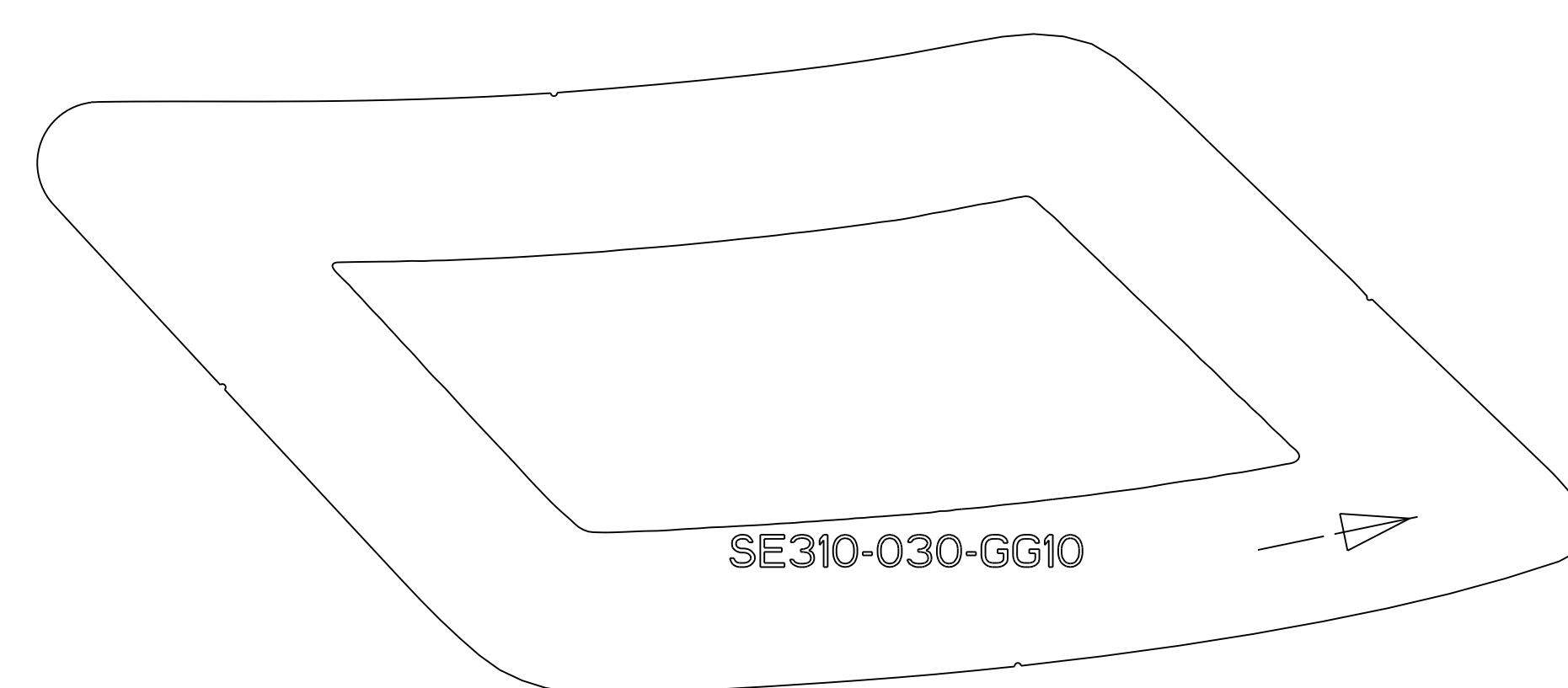

SE310-030-GG10  
QNTY 1

RELEASE LEVEL:  
DWG VERSION NO:

WEIGHT  
0.0 lbs  
MODEL NAME  
SE310-030-HH7  
WELDING ENGINEER

PART NO.	DRAWING NO	NOMENCLATURE OR DESCRIPTION	MATERIAL	QTY RECD	SEE NOTES
PARTS LIST					
COMPUTER GENERATED DRAWING MANUAL CHANGES NOT PERMITTED Pro E		CENTRAL FILES: UNLESS OTHERWISE SPECIFIED DIMENSIONS ARE IN INCHES MACHINE SURFACES BREAK SHARP EDGES .005/0.020	PRINCETON PLASMA PHYSICS LABORATORY PRINCETON UNIVERSITY NATIONAL COMPACT STELLARATOR EXPERIMENT DIAGNOSTICS MAGNETIC DIAGNOSTICS MAGNETIC LOOPS SERIES "G"		
DO NOT VERIFY INFORMATION BY SCALING DRAWING	TOLERANCES NON-CUMULATIVE	DSN: T. BROWN	1/12/06	DRAWING NO:	
NEXT ASSEMBLY	DECIMAL-INCH FRACTIONS .X +/- .000 .XX +/- .000 .XXX +/- .005 ANGULAR +/- .05	CHK: J. RUSHINSKI	1/12/06	SE310-030-A.Q	
		ENGR: G. LABIK	1/12/06	SHEET 5 OF 15 REV 0	
		SUPV: J. SIEGEL	1/12/06	NCSX-PART-FORMAT.E	

NCSX-SE310-030-A.Q

NO.	REVISION	BY	CH	SUP	APPROVED	DATE

FOR NOTES SEE SHEET 1

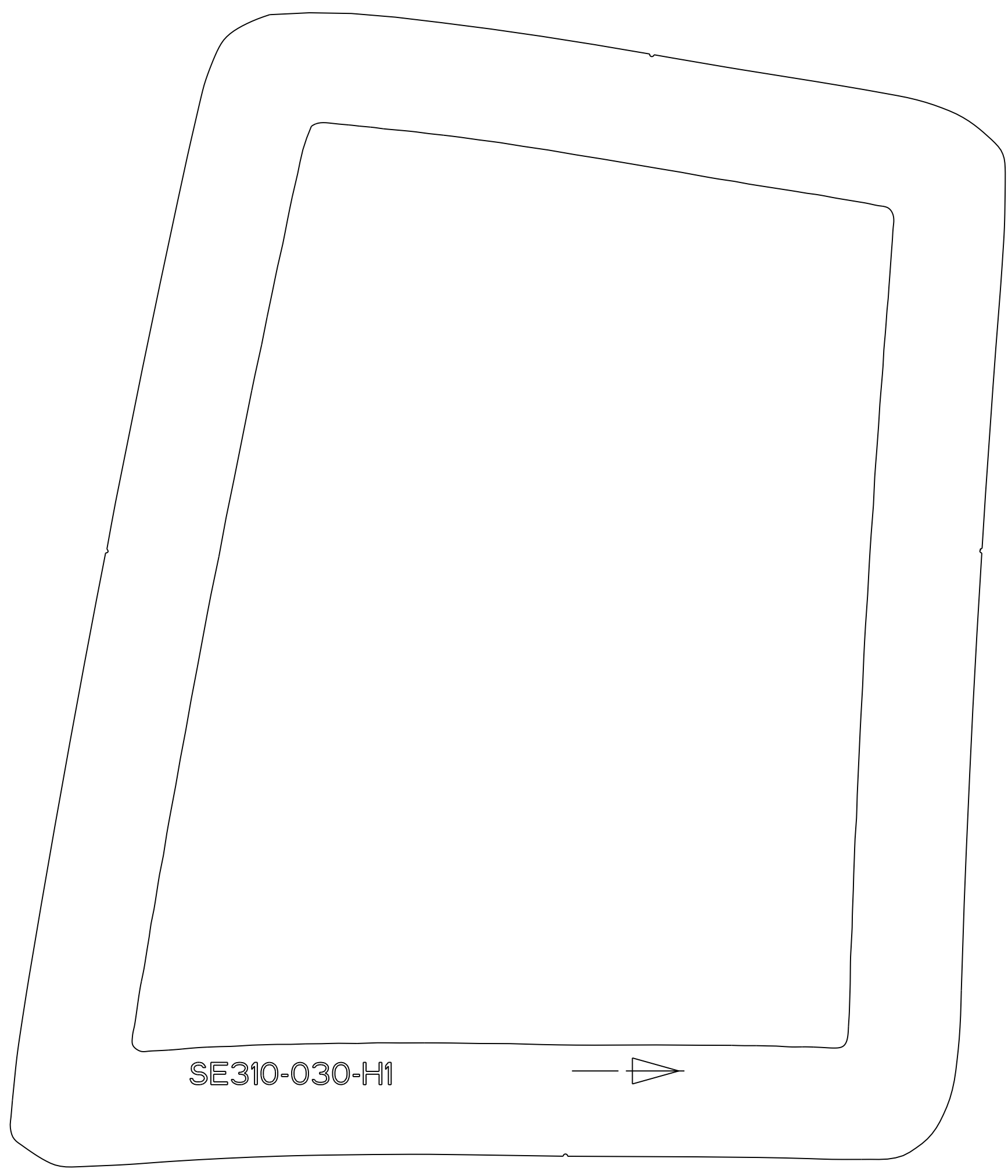

SE310-030-H1  
QNTY 1

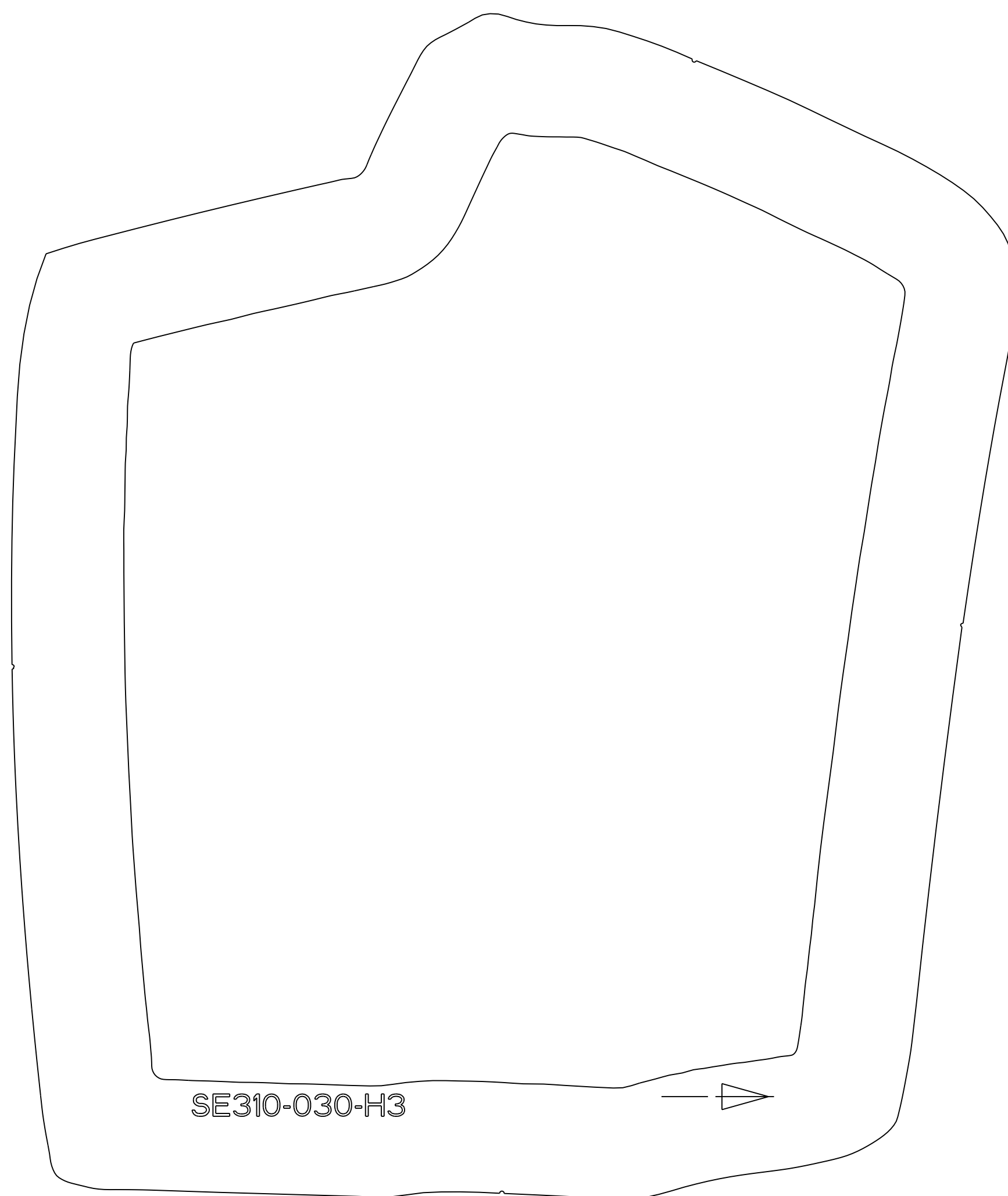

SE310-030-H3  
QNTY 1

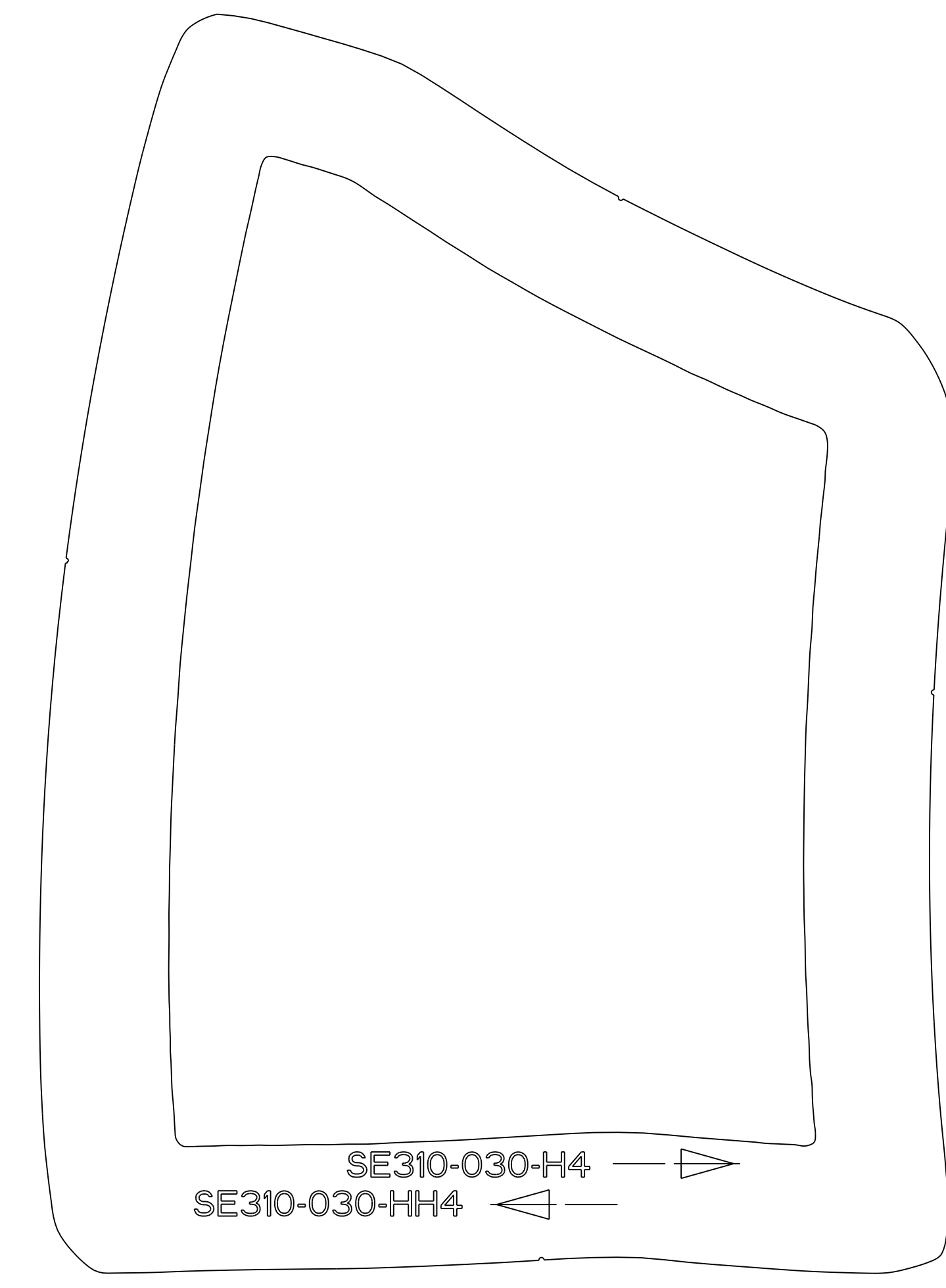

SE310-030-H4  
QNTY 1

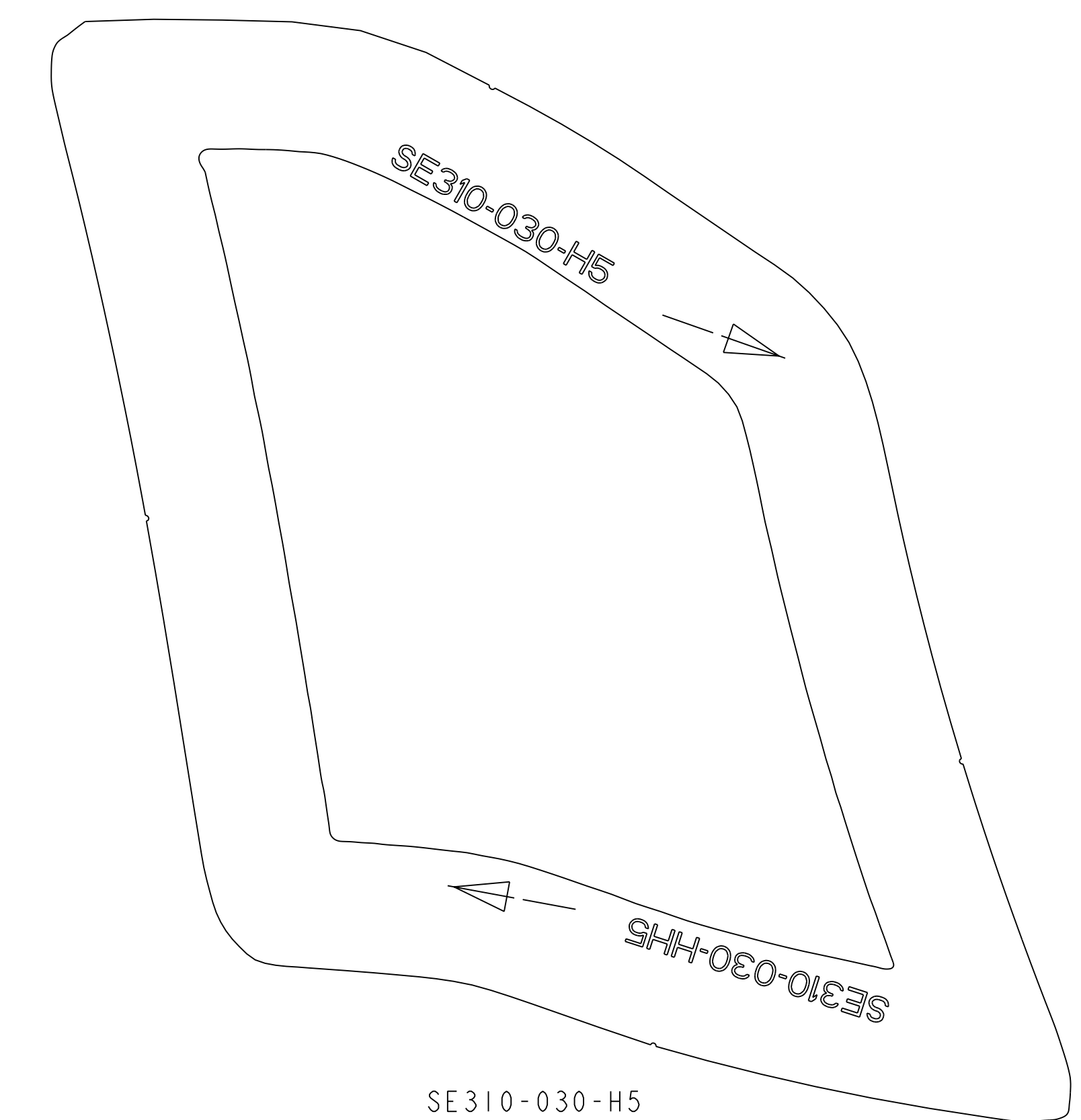

SE310-030-H5  
QNTY 2

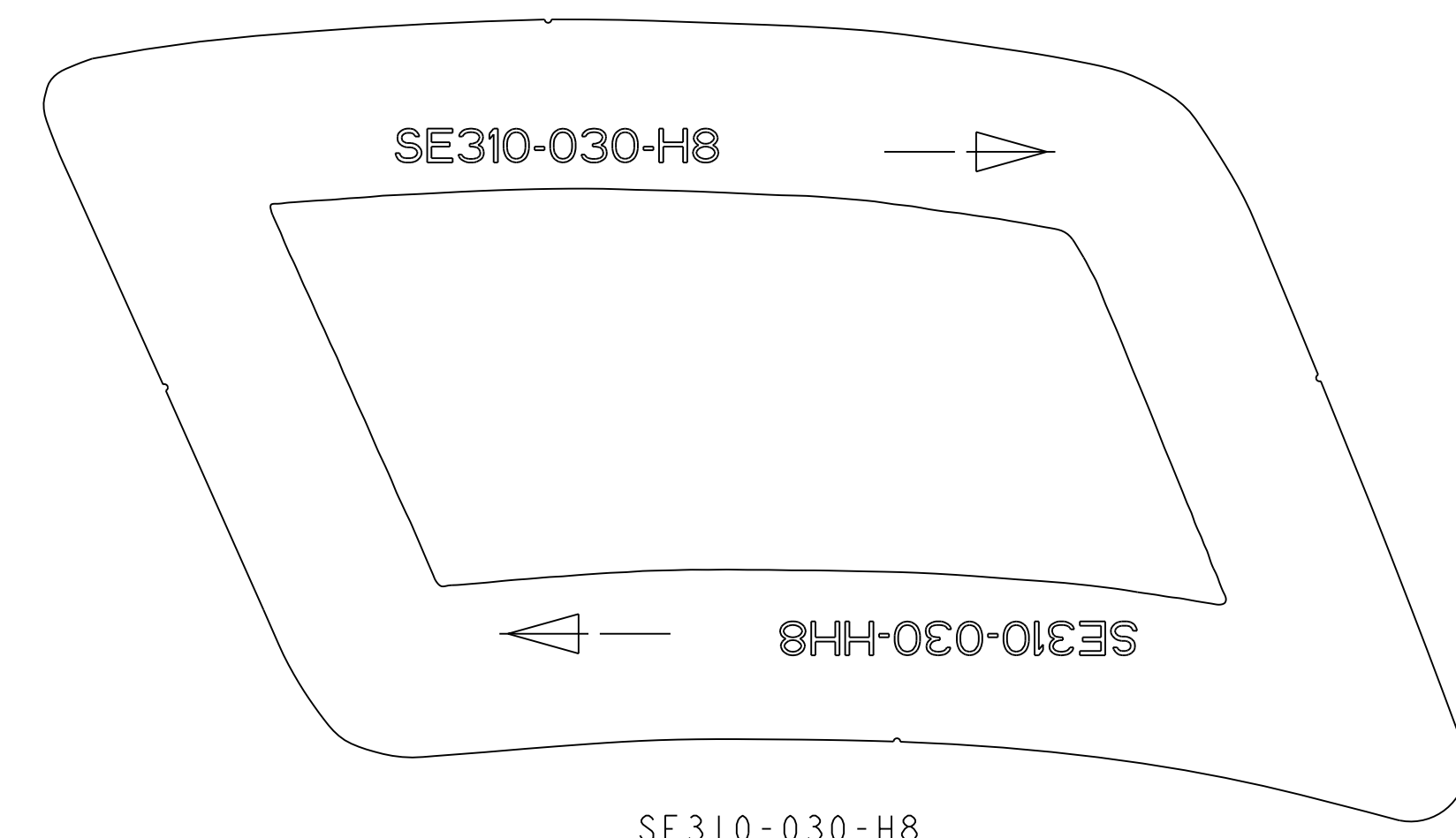

SE310-030-H8  
QNTY 1

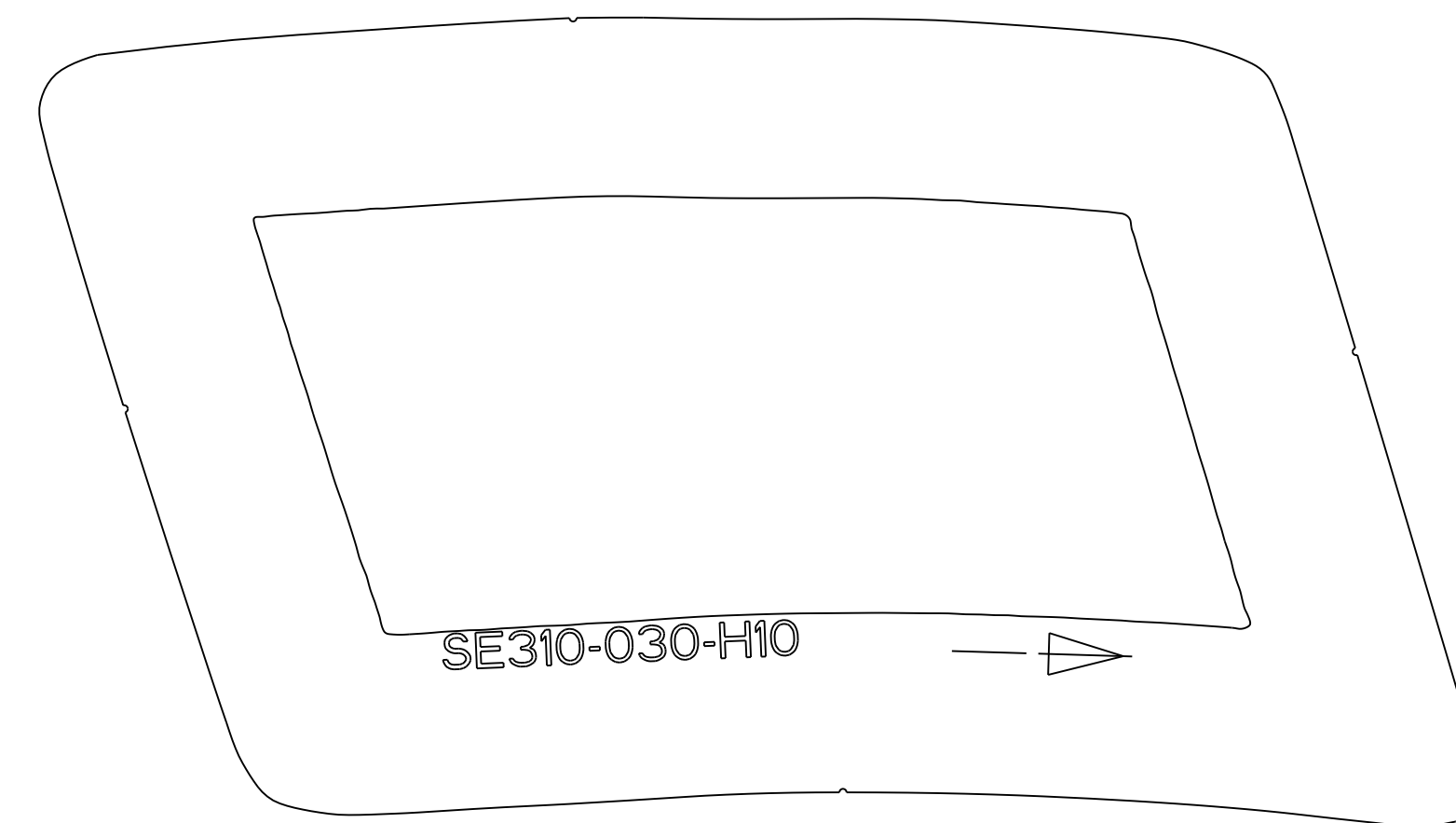

SE310-030-H10  
QNTY 1

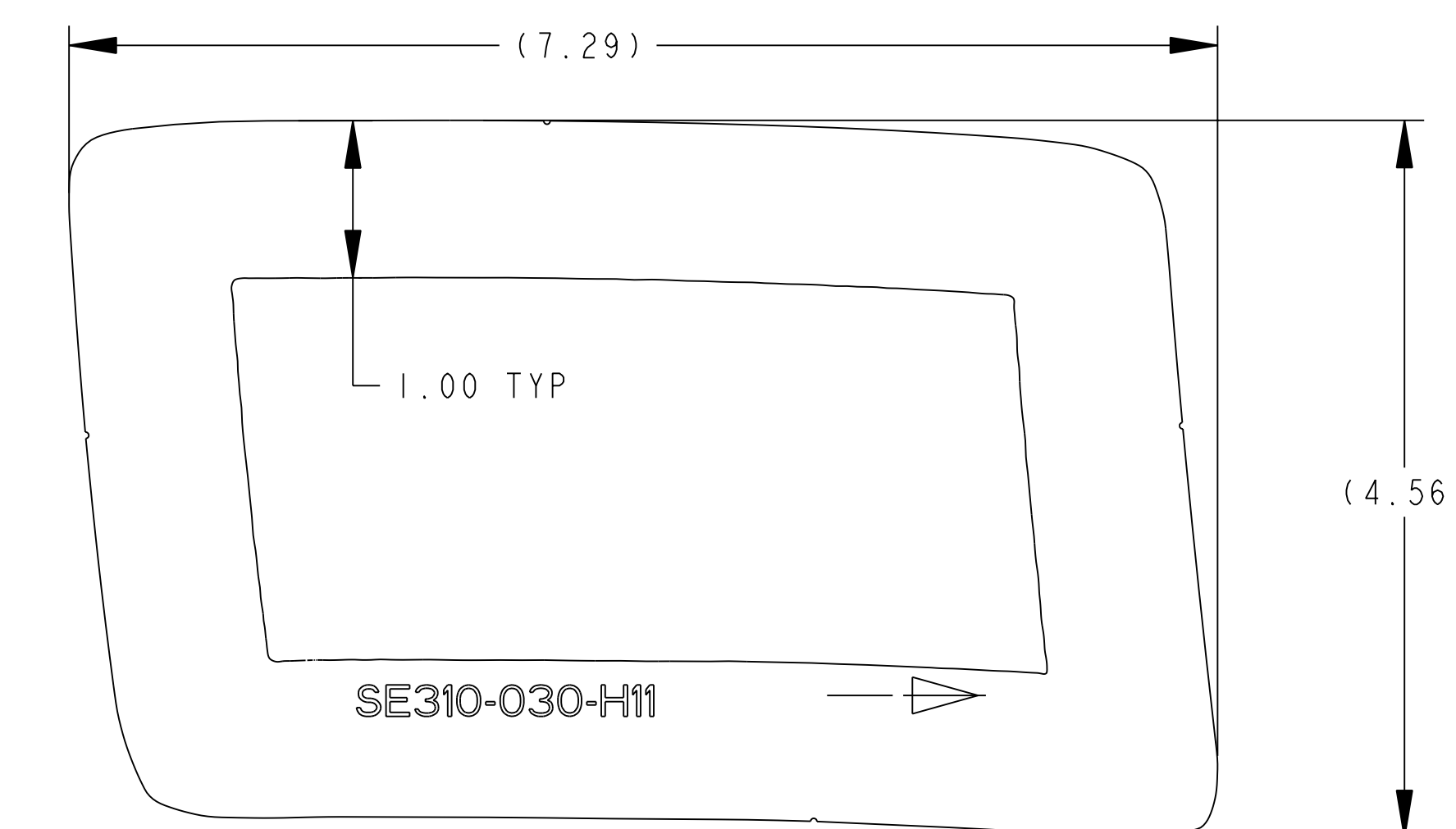

SE310-030-H11  
QNTY 1

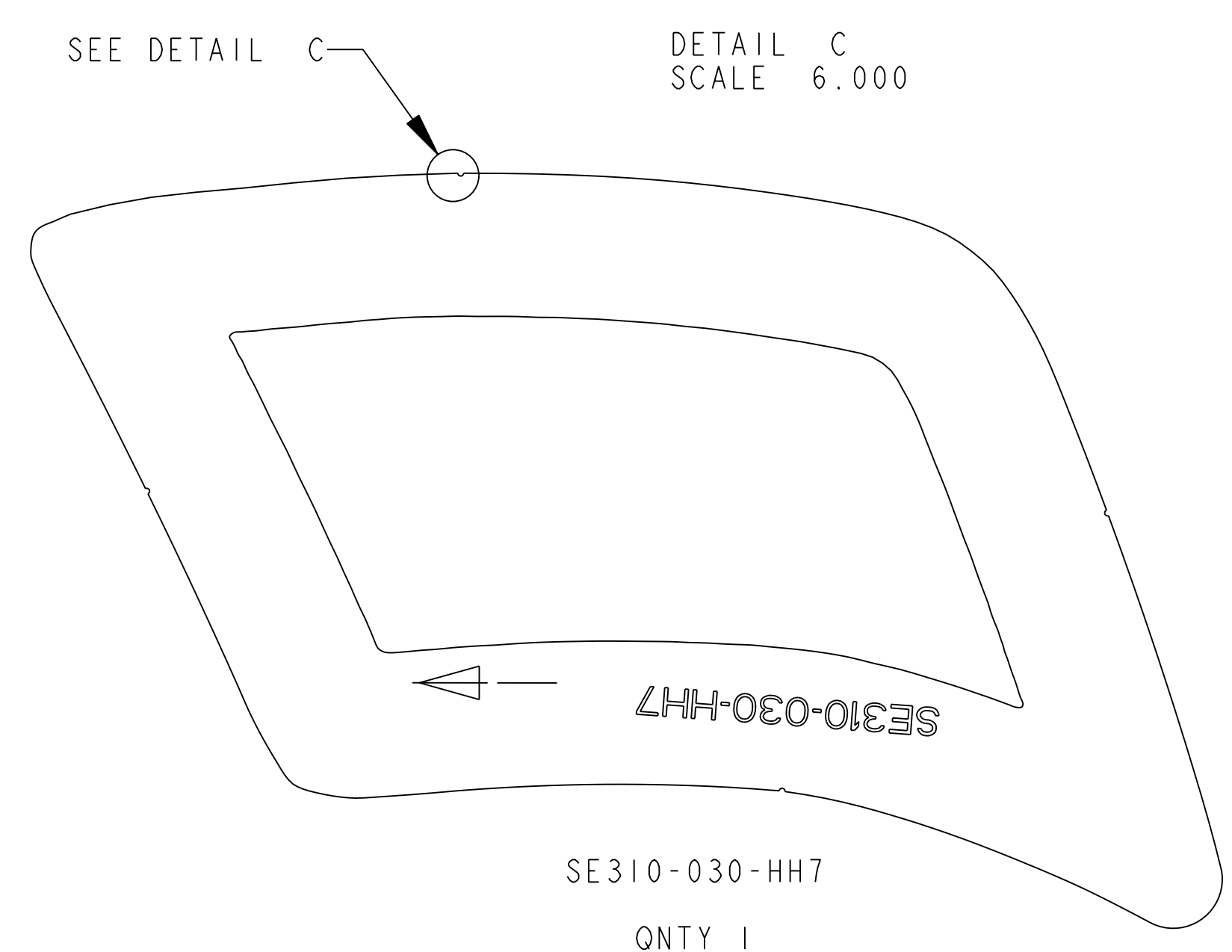
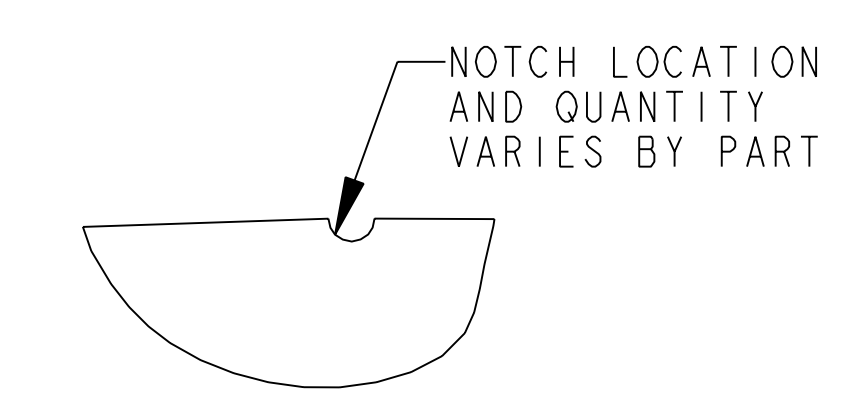

SE310-030-HH7  
QNTY 1

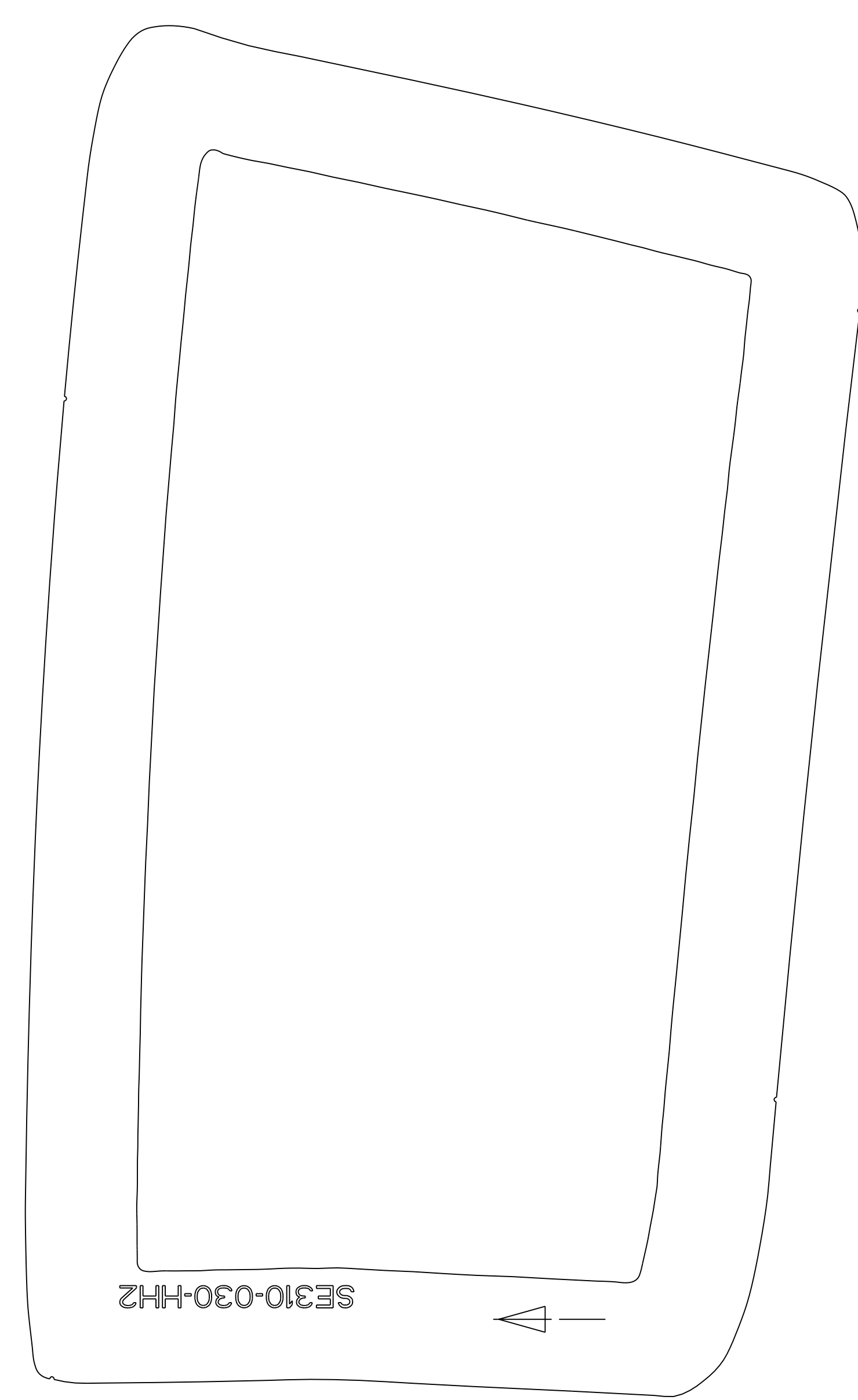

SE310-030-HH2  
QNTY 1

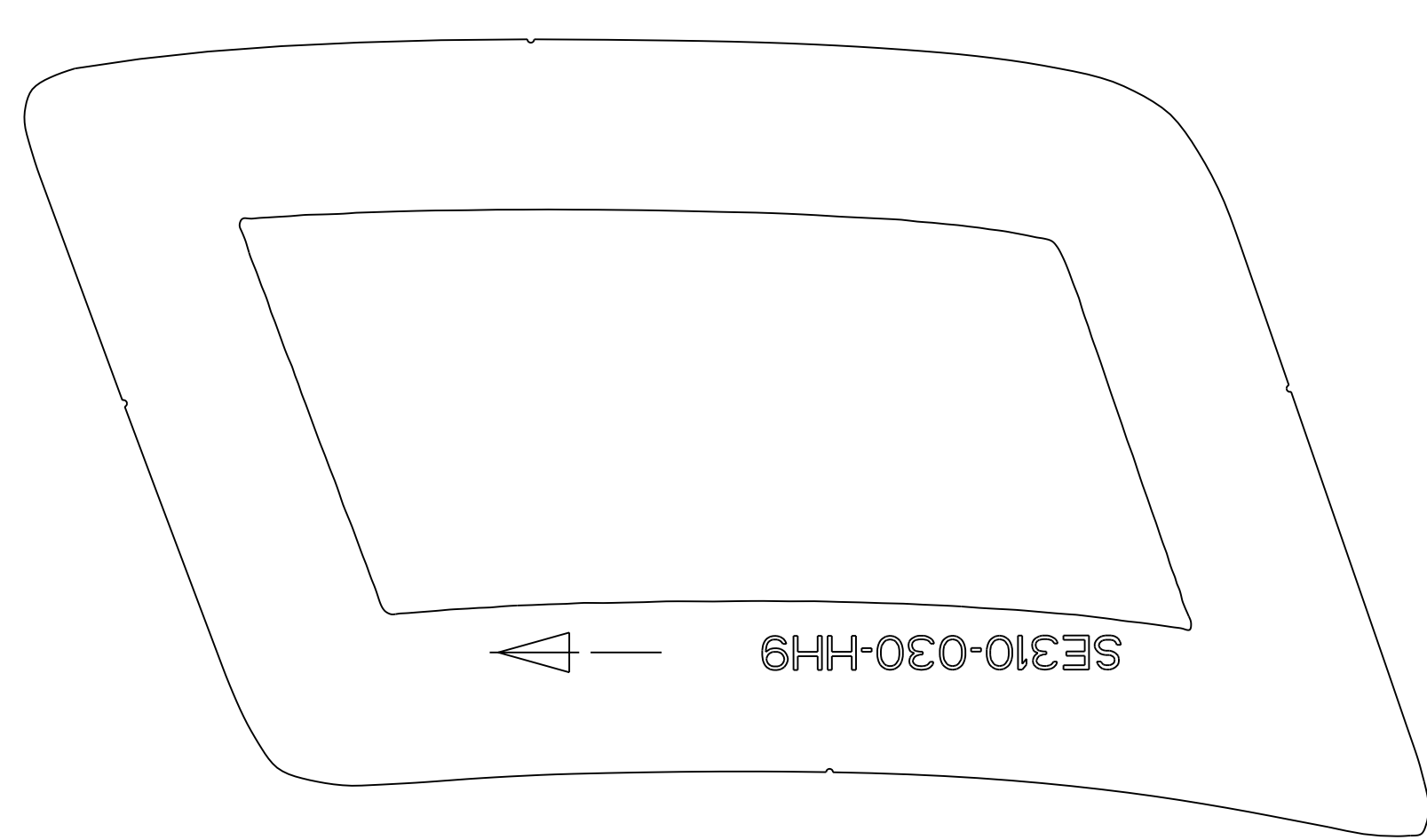

SE310-030-HH9  
QNTY 1

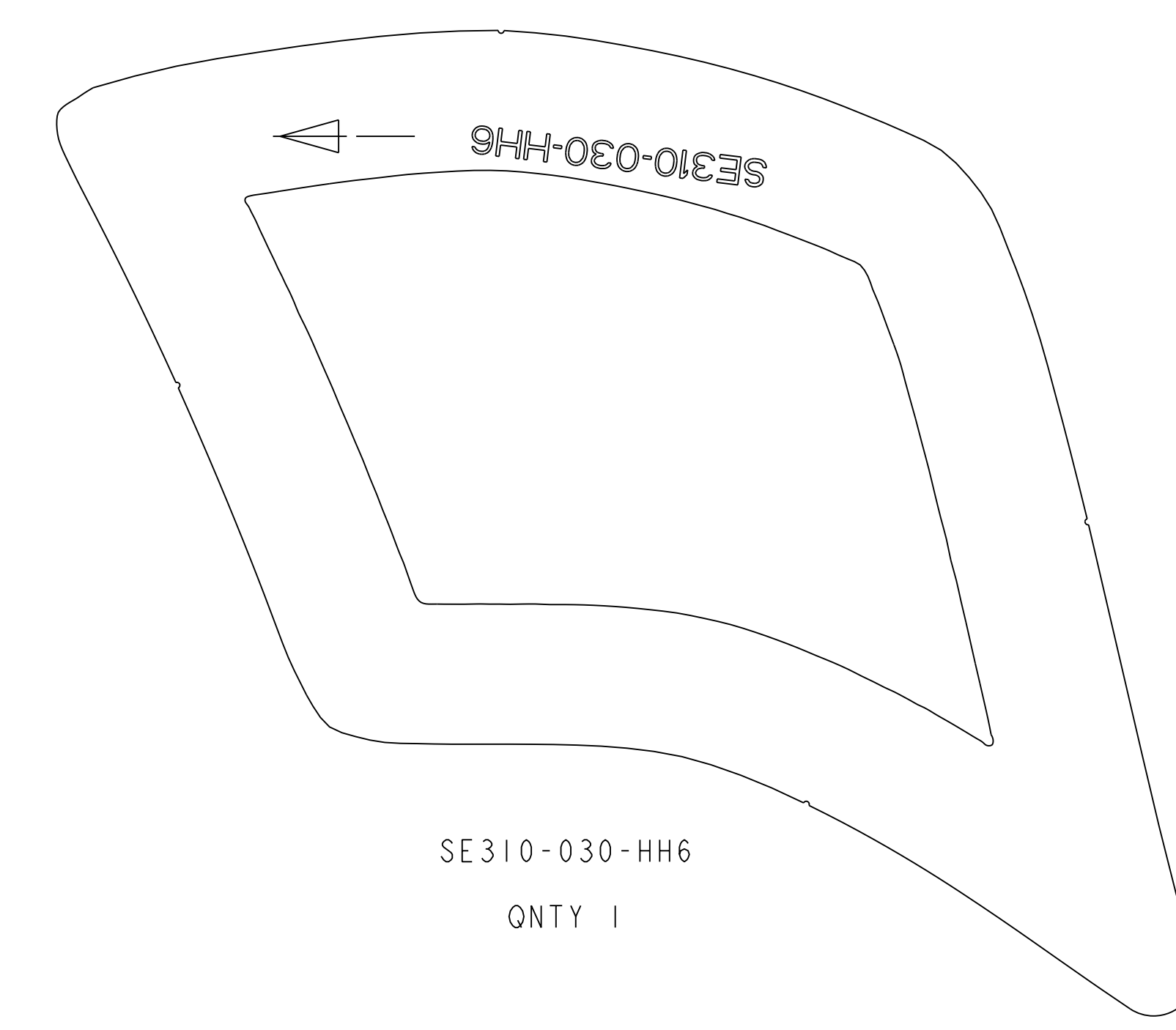

SE310-030-HH6  
QNTY 1

PART NO.	DRAWING NO	NOMENCLATURE OR DESCRIPTION	MATERIAL	QTY RECD	SEE NOTES
PARTS LIST					
COMPUTER GENERATED DRAWING DRAWING CHANGES NOT PERMITTED Pro E	CENTRAL FILES: UNLESS OTHERWISE SPECIFIED	PRINCETON PLASMA PHYSICS LABORATORY NATIONAL COMPACT STELLARATOR EXPERIMENT			
DO NOT VERIFY INFORMATION BY SCALING DRAWING	DIMENSIONS ARE IN INCHES MACHINE SURFACES BREAK SHARP EDGES .005/0.020	DIAGNOSTICS MAGNETIC DIAGNOSTICS MAGNETIC LOOPS SERIES "H"			
TOLERANCES NON-CUMULATIVE	DECIMAL-INCH FRACTIONS	DSN: T. BROWN 1/12/06	DRAWING NO:		
NEXT ASSEMBLY	.XX +/- .000 .XXX +/- .005 ANGULAR +/- 0°-15'	CHK: J. RUSHINSKI 1/12/06	SE310-030-A.Q		
		ENGR: G. LABIK 1/12/06	SHEET 6 OF 15 REV 0		
		SUPV: J. SIEGEL 1/12/06	NCSX-PART-FORMAT.E		

RELEASE LEVEL: WIP  
DWG VERSION NO: 8

WEIGHT  
0.0 lbs  
MODEL NAME  
SE310-030-HH7  
WELDING ENGINEER

NCSX-SE310-030-A.Q

NO.	REVISION	BY	CH	SUP	APPROVED	DATE

FOR NOTES SEE SHEET 1

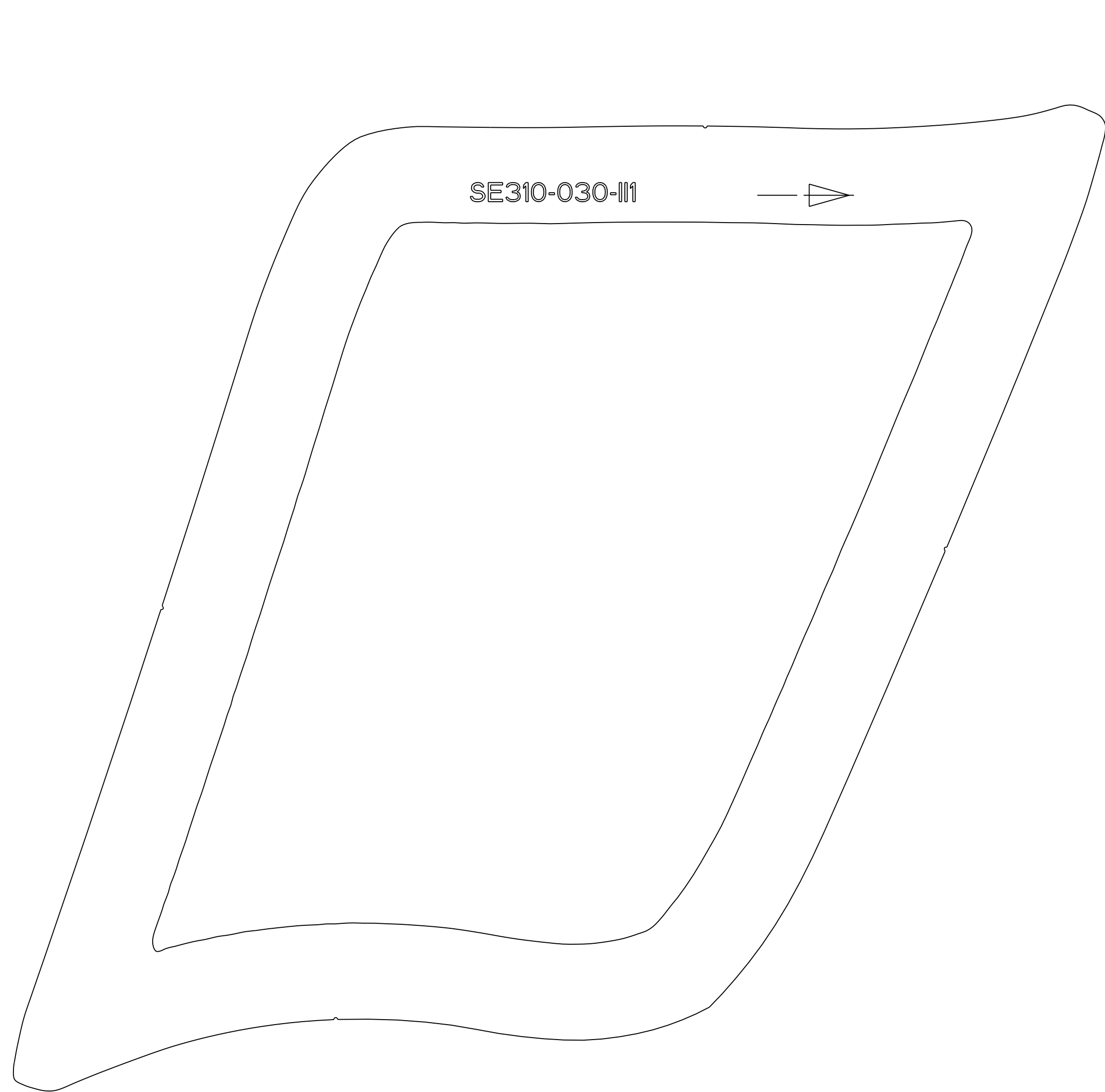

SE310-030-111  
QNTY 1

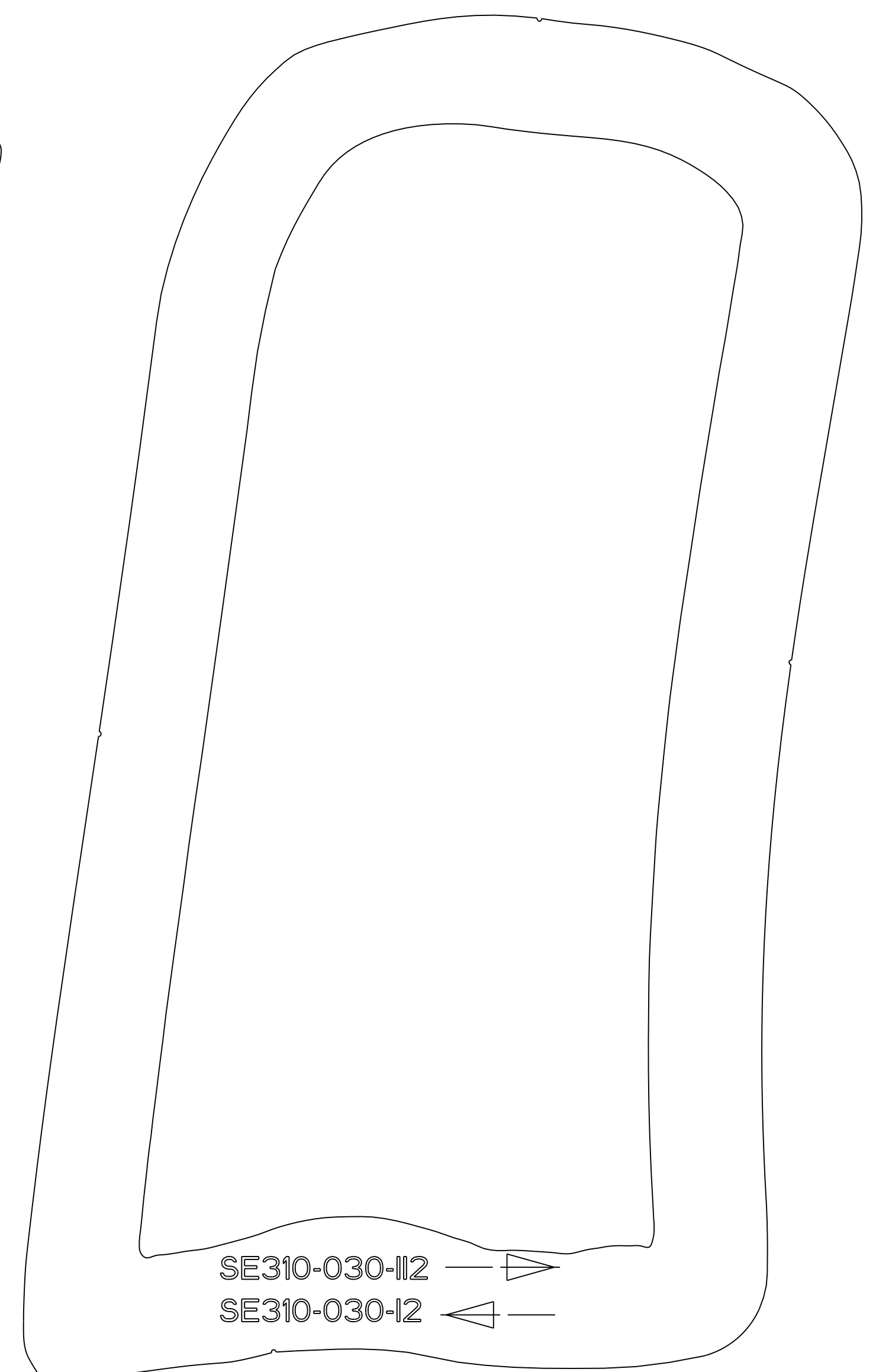

SE310-030-112  
QNTY 1

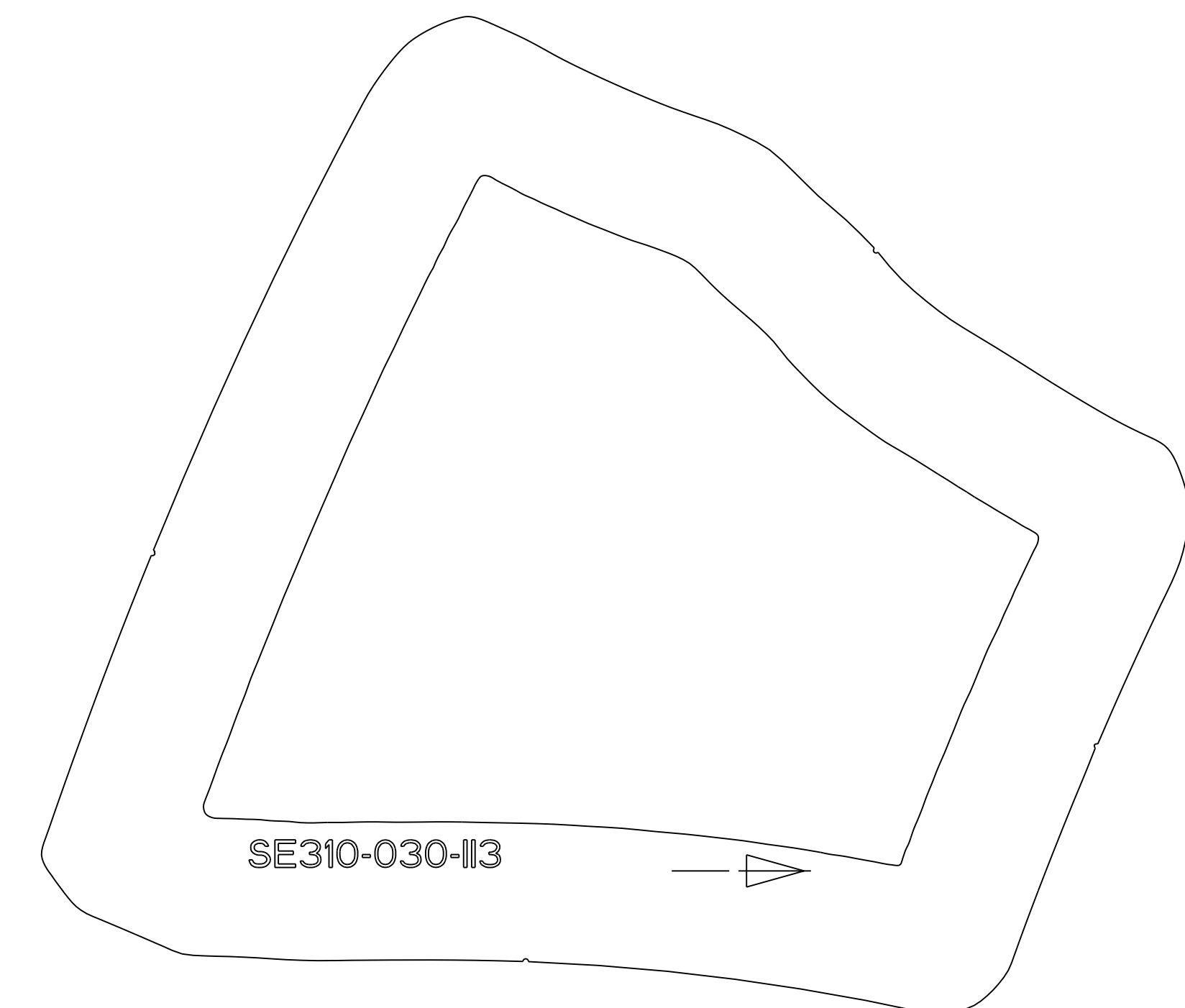

SE310-030-113  
QNTY 1

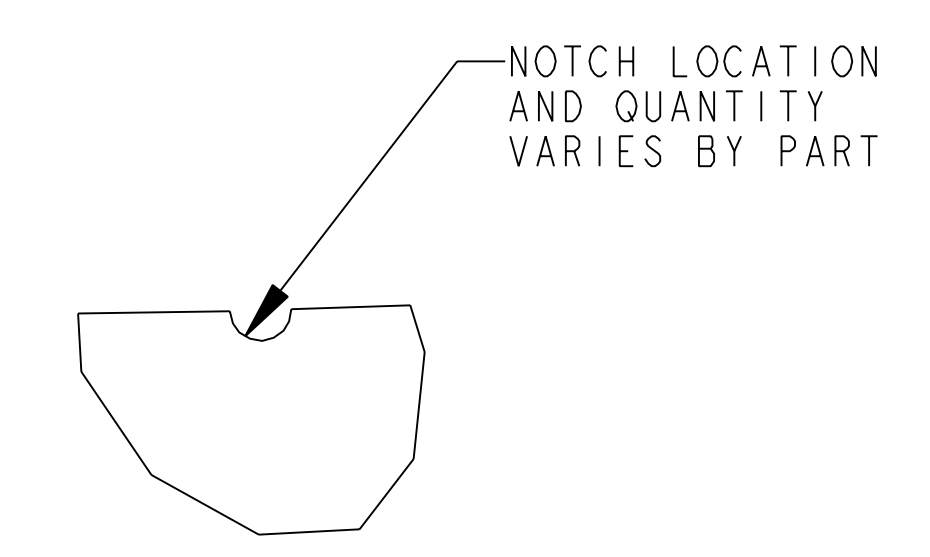

DETAIL A  
SCALE 8.000

SEE DETAIL A

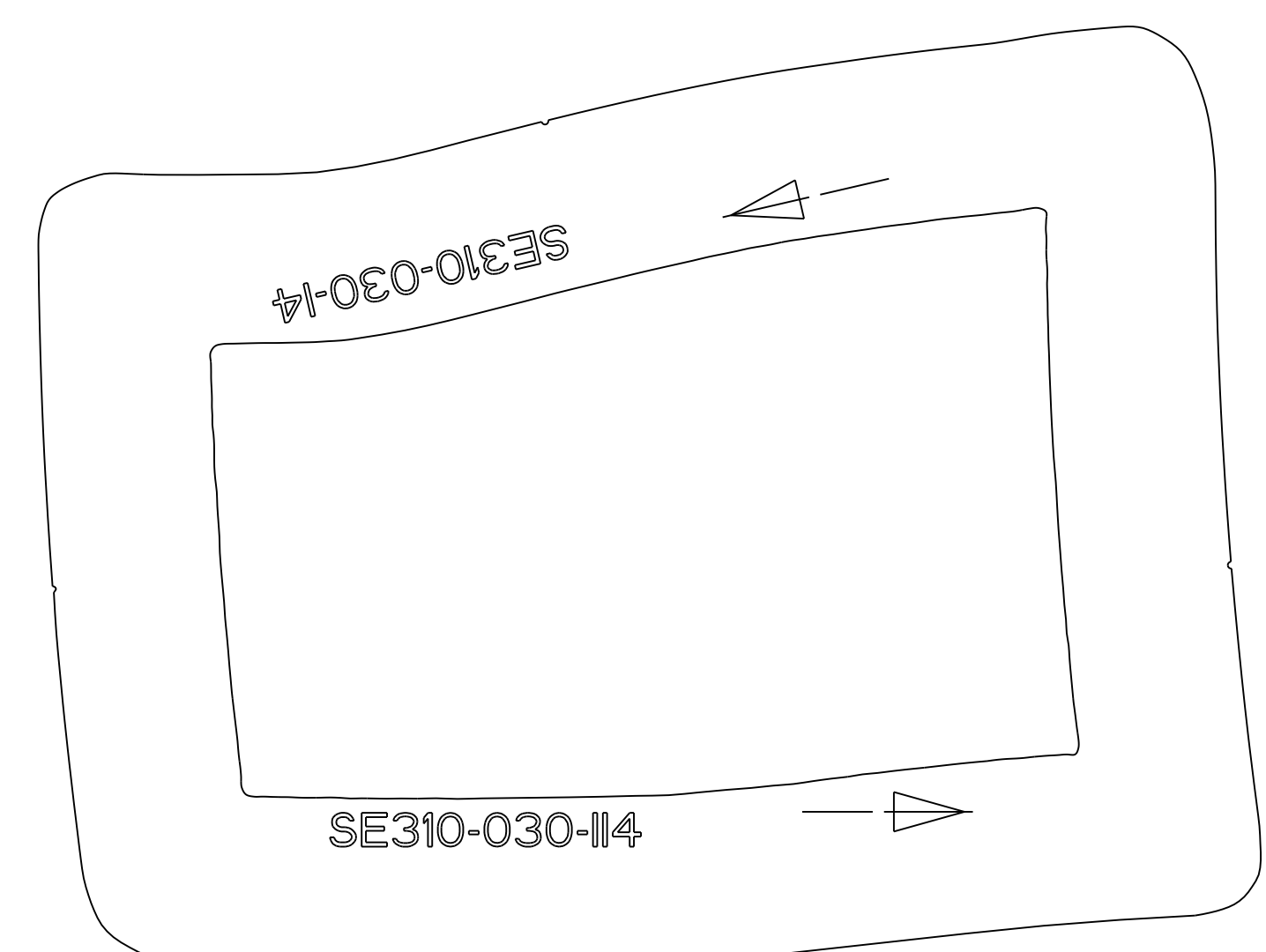

SE310-030-114  
QNTY 2

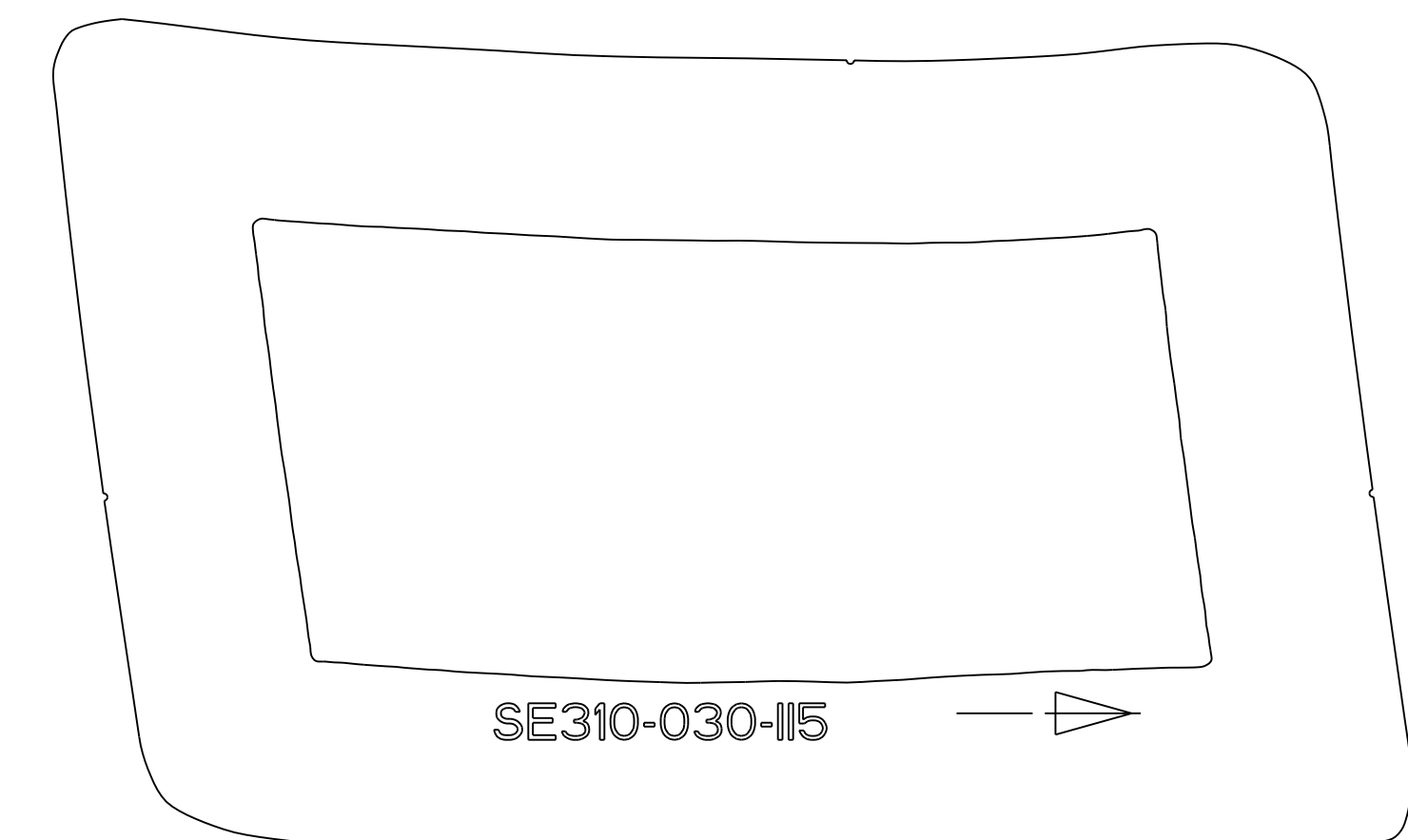

SE310-030-115  
QNTY 1

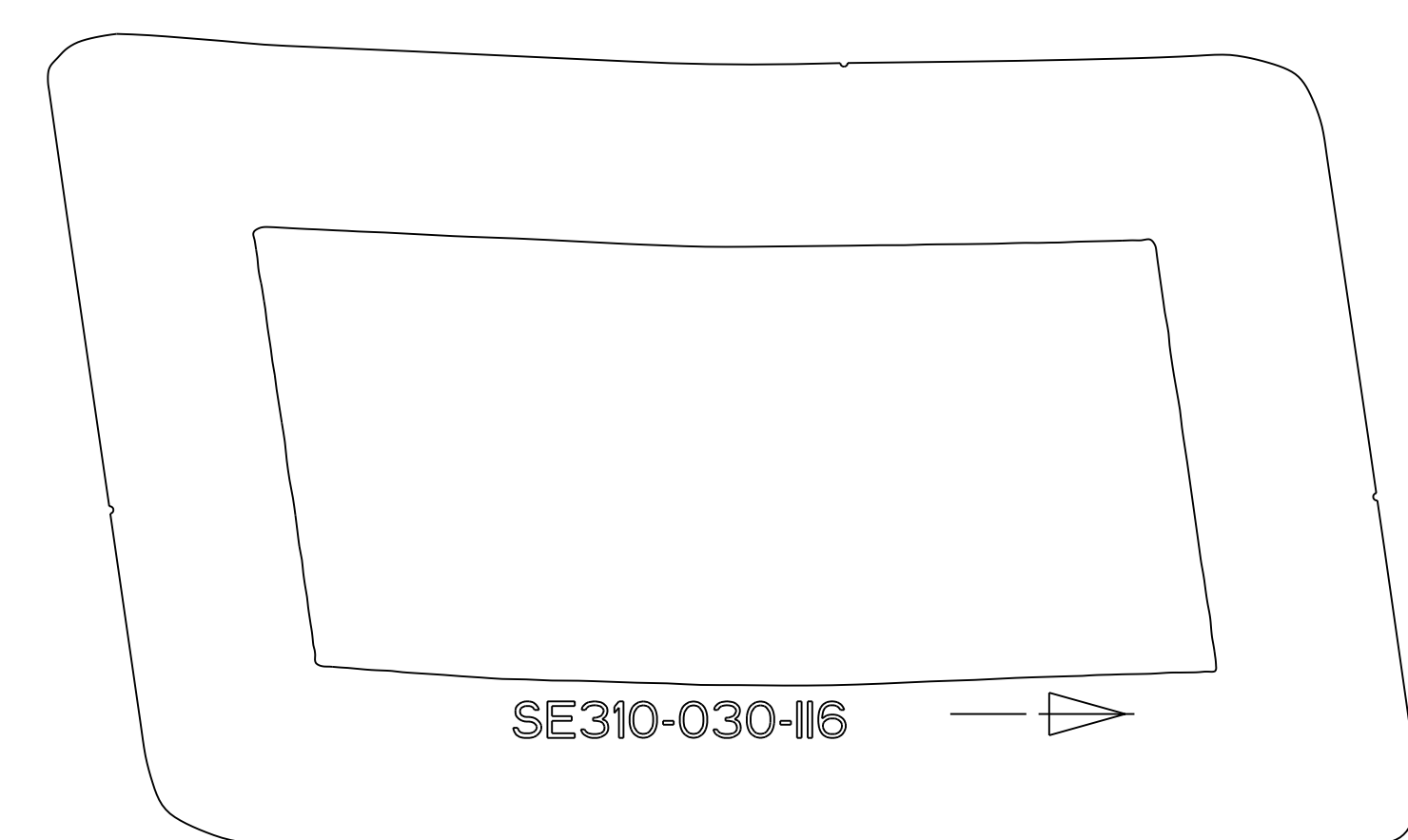

SE310-030-116  
QNTY 1

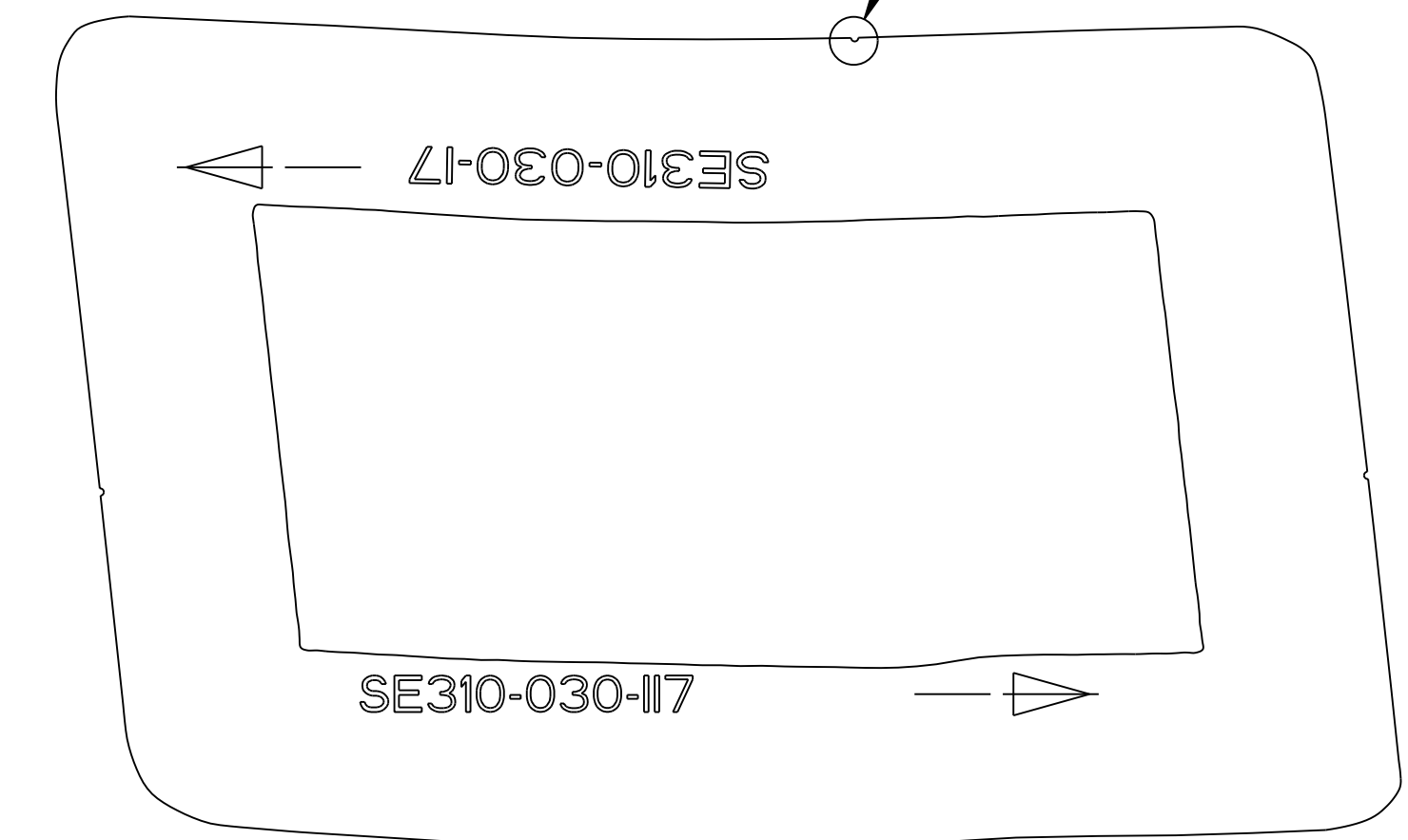

SE310-030-117  
QNTY 1

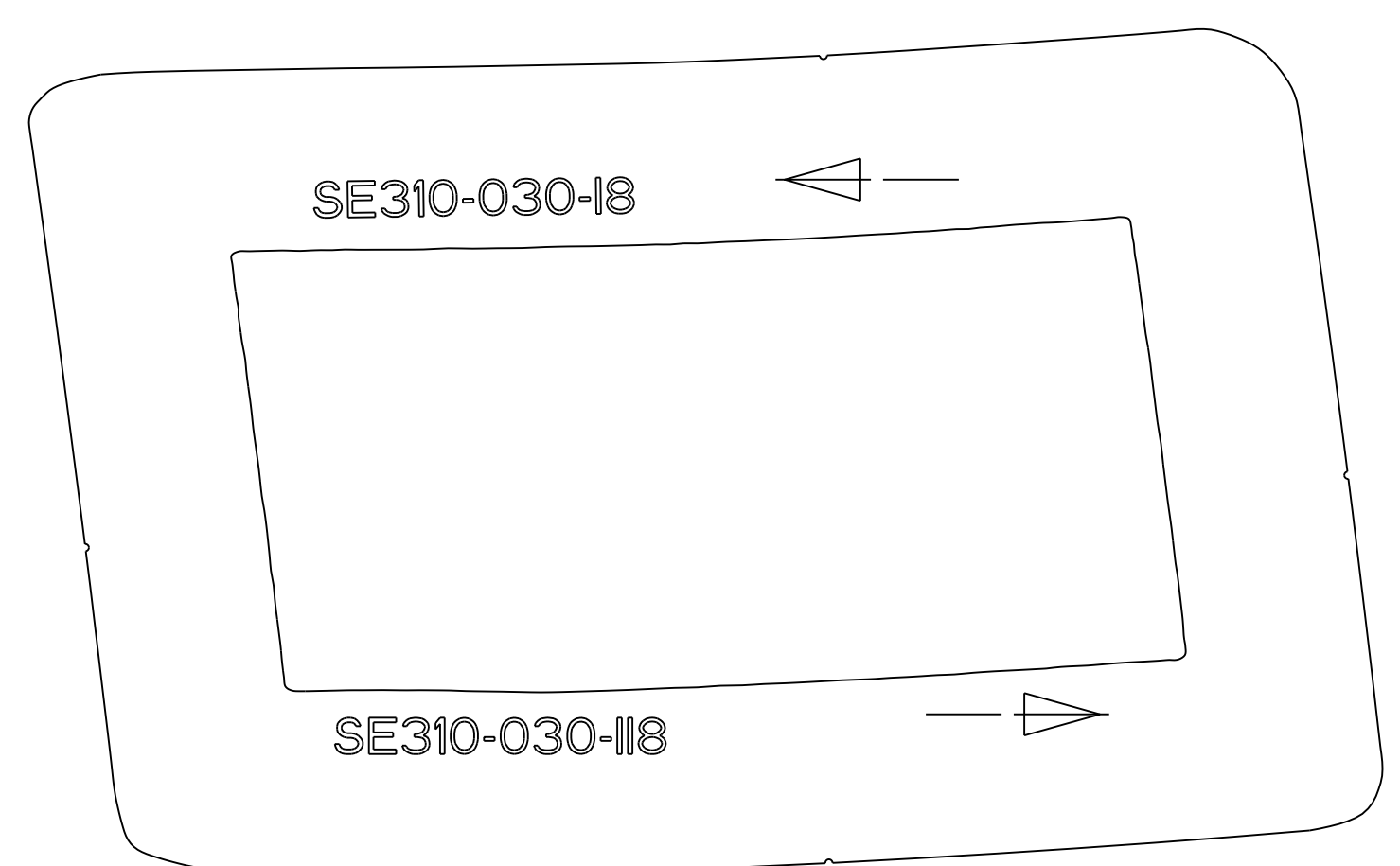

SE310-030-118  
QNTY 1

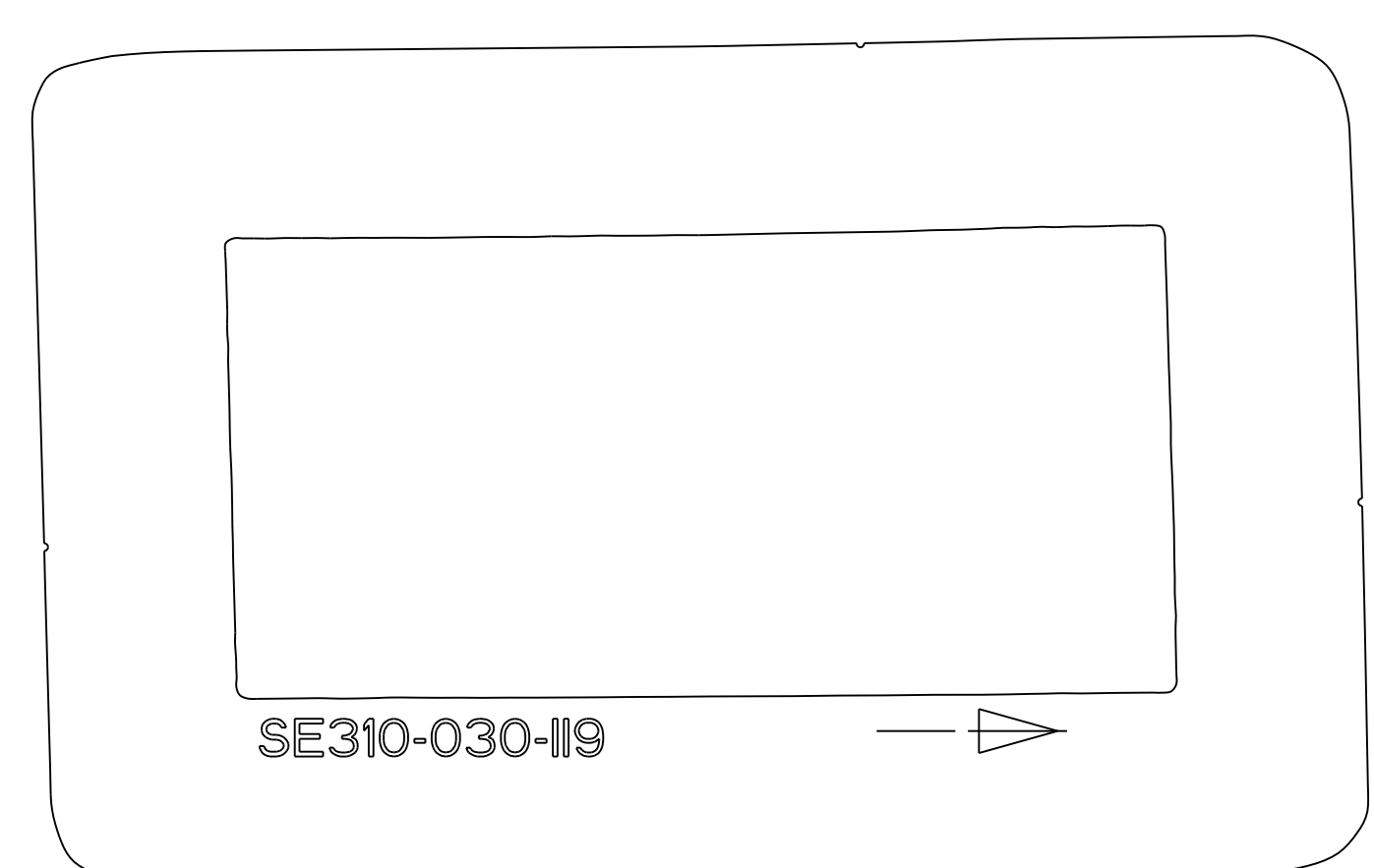

SE310-030-119  
QNTY 1

PART NO.	DRAWING NO	NOMENCLATURE OR DESCRIPTION	MATERIAL	QTY REOD	SEE NOTES
		PARTS LIST			
COMPUTER GENERATED DRAWING MANUAL CHANGES NOT PERMITTED Pro E	CENTRAL FILES: UNLESS OTHERWISE SPECIFIED	PRINCETON PLASMA PHYSICS LABORATORY NATIONAL COMPACT STELLARATOR EXPERIMENT			
DO NOT VERIFY INFORMATION BY SCALING DRAWING	DIMENSIONS ARE IN INCHES MACHINE SURFACES BREAK SHARP EDGES .005/.020	DIAGNOSTICS MAGNETIC DIAGNOSTICS MAGNETIC LOOPS SERIES "I"			
	TOLERANCES NON-CUMULATIVE	DSN: T. BROWN	1/12/06	DRAWING NO:	
NEXT ASSEMBLY	DECIMAL-INCH FRACTIONS	CHK: JRUSHINSKI	1/12/06	SE310-030-A.Q	
	.XX +/- .030 12°-12° +/- .178	ENGR: G. LABIK	1/12/06	SHEET 7 OF 15 REV 0	
	.XXX +/- .005 72°-120° +/- .174 ANGULAR +/- .0°-15° OVER 120° +/- .172	SUPV: J. SIEGEL	1/12/06	NCSX-PART-FORMAT.E	

WEIGHT  
0.0 lbs

MODEL NAME  
SE310-030-HH7

WELDING ENGINEER

RELEASE LEVEL:  
DWG VERSION NO:

NCSX-SE310-030-A.Q

NO.	REVISION	BY	CH	SUP	APPROVED	DATE

FOR NOTES SEE SHEET 1

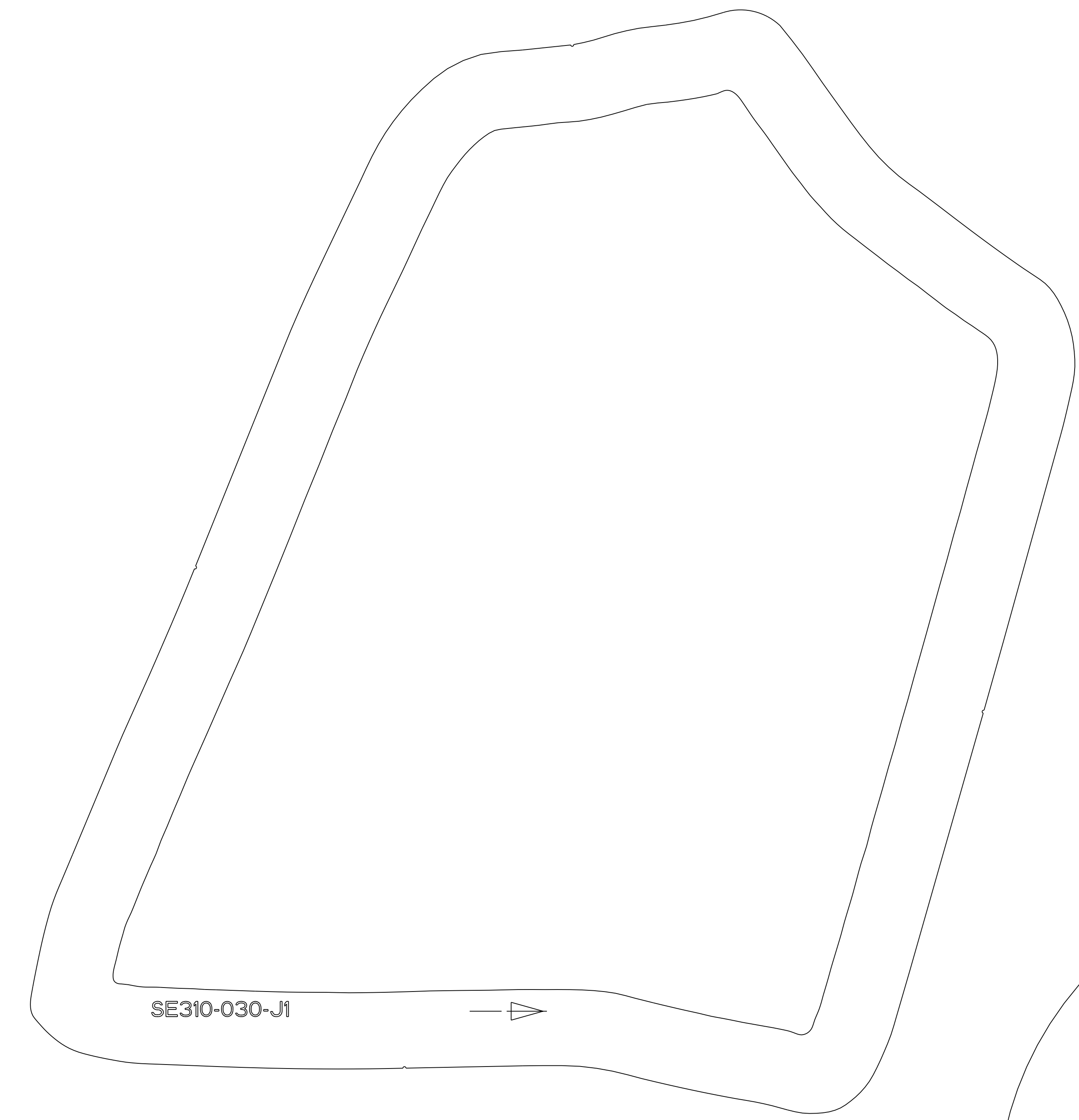
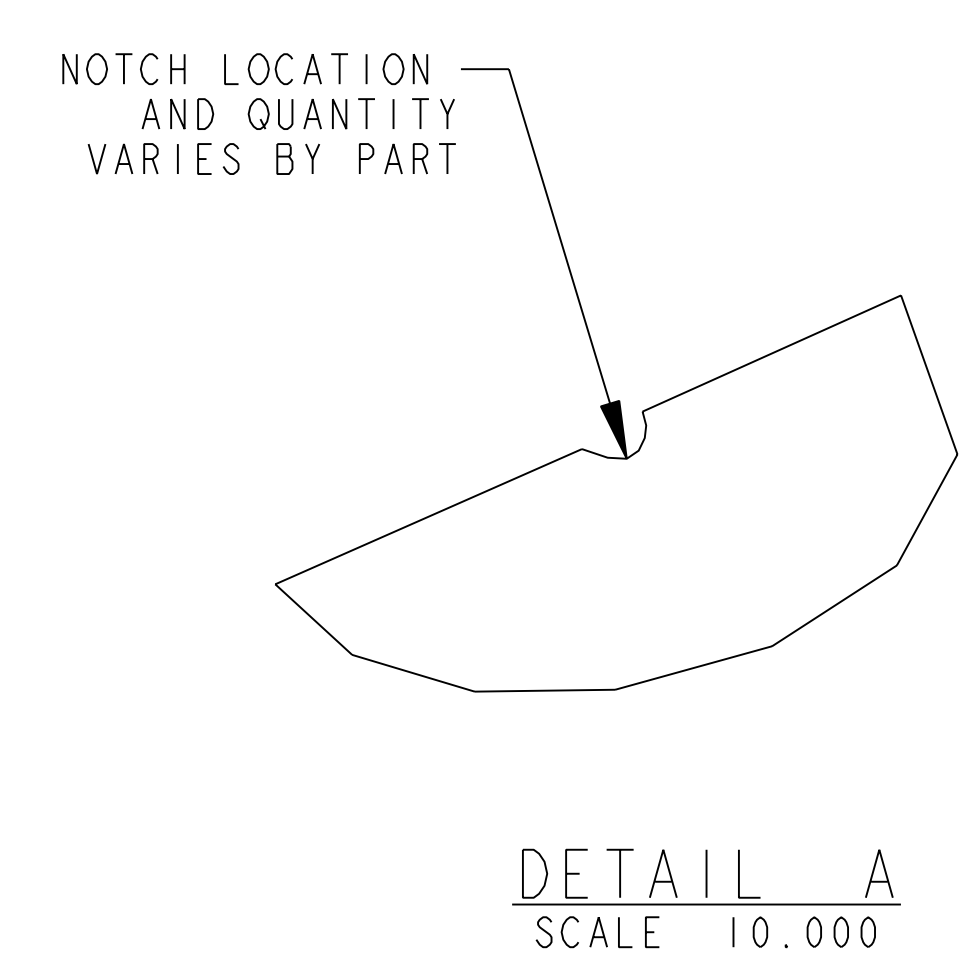

SE310-030-J1  
QNTY 1

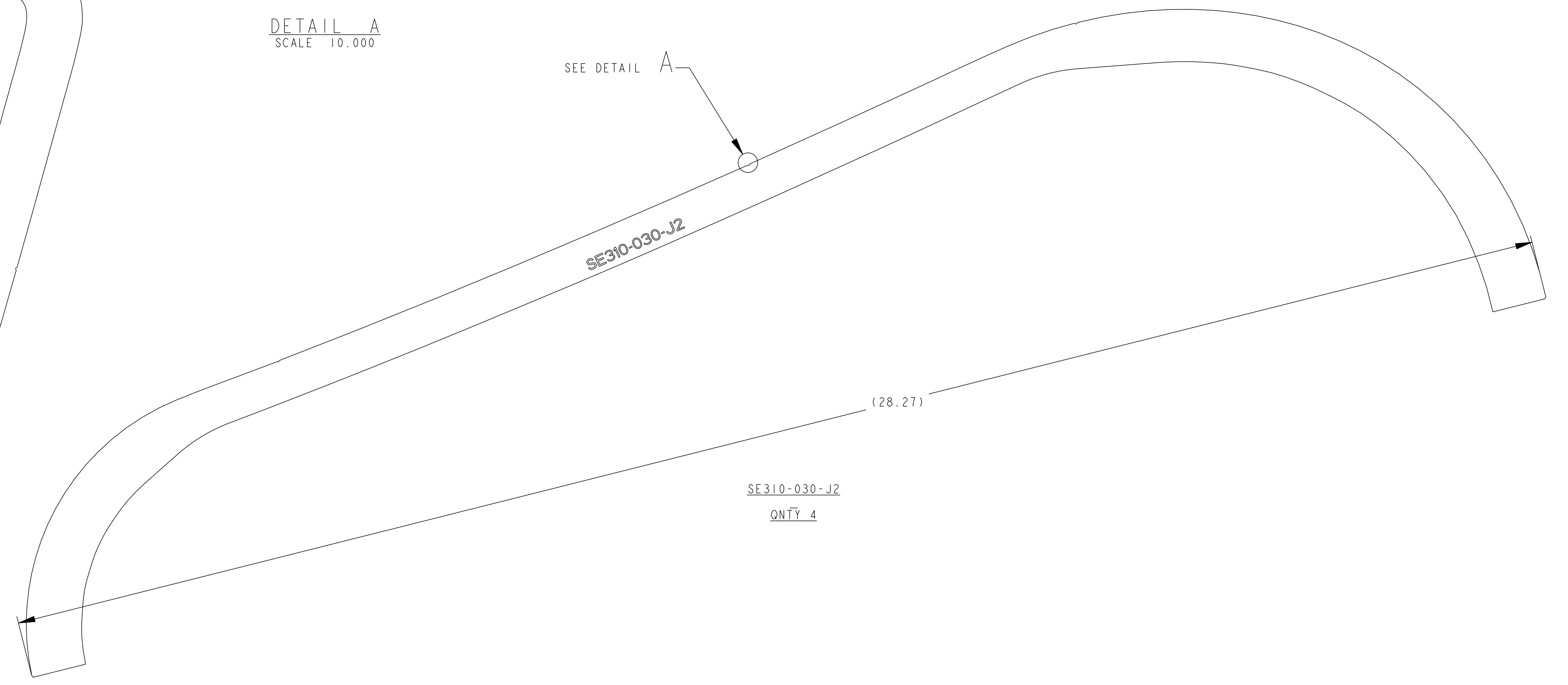

SE310-030-J2  
QNTY 4

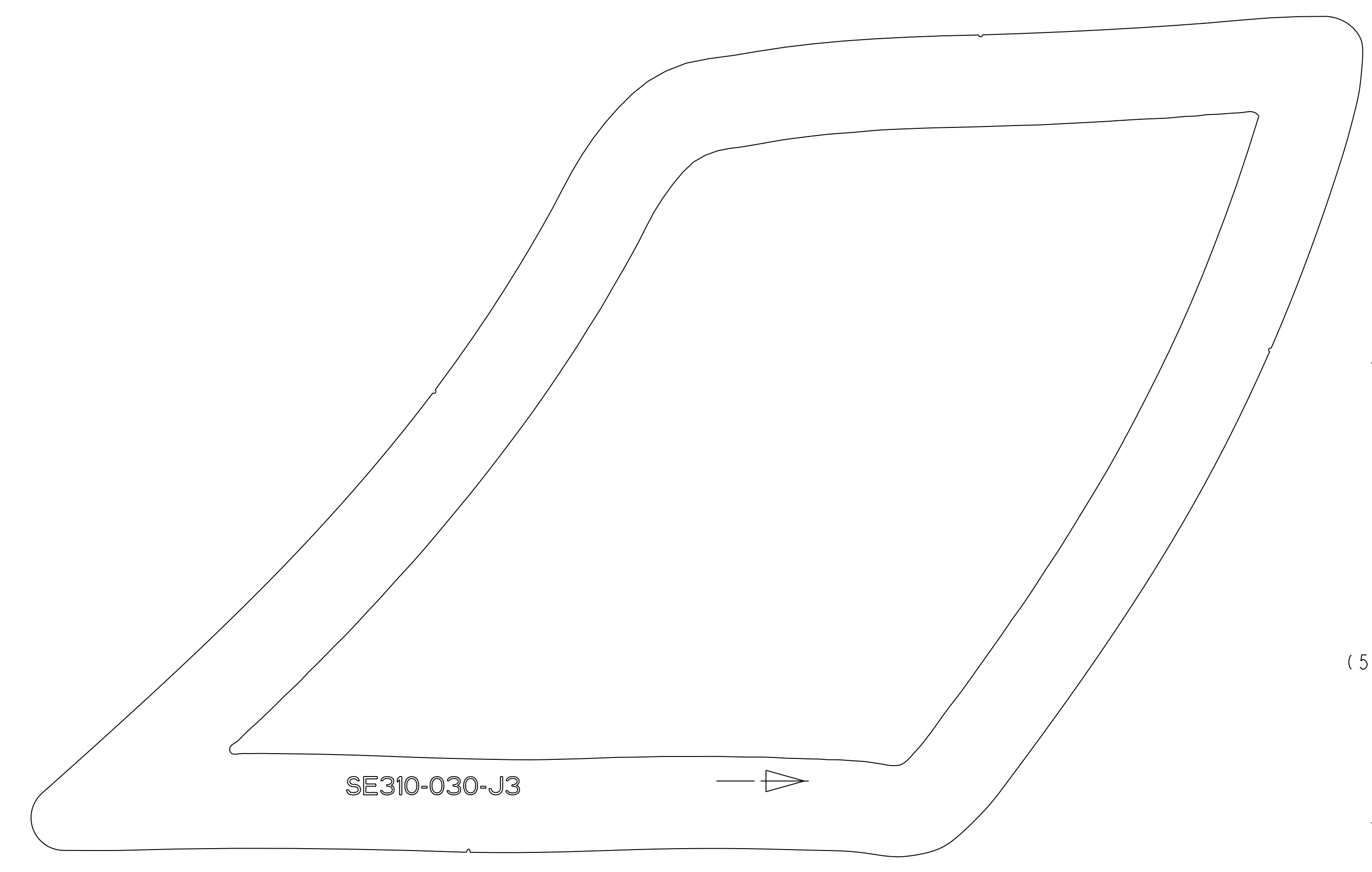

SE310-030-J3  
QNTY 1

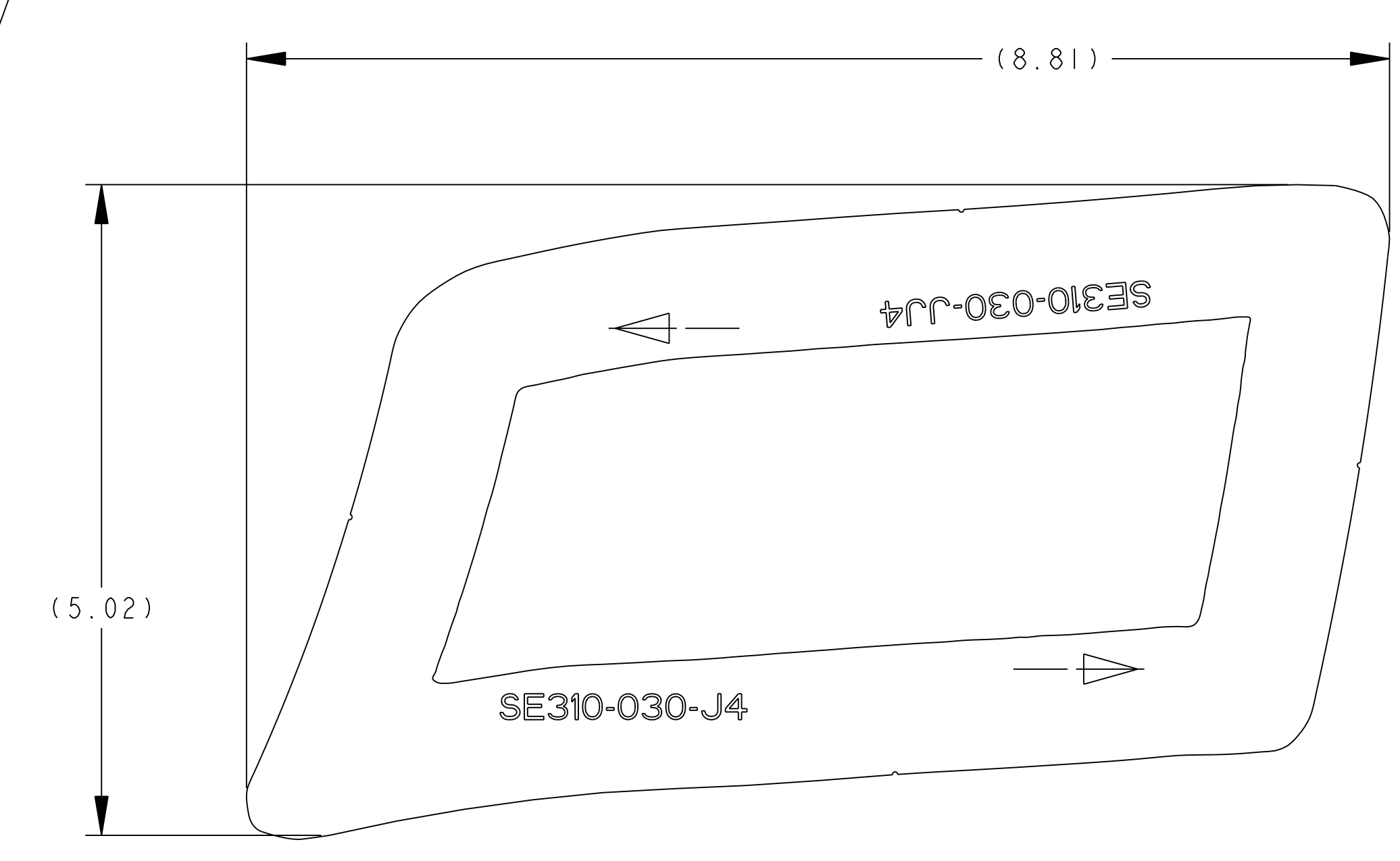

SE310-030-J4  
QNTY 1

PART NO.	DRAWING NO	NOMENCLATURE OR DESCRIPTION	MATERIAL	QTY RECD	SEE NOTES
PARTS LIST					
COMPUTER GENERATED DRAWING DRAWING CHANGES NOT PERMITTED Pro E		CENTRAL FILES: UNLESS OTHERWISE SPECIFIED	PRINCETON PLASMA PHYSICS LABORATORY PRINCETON UNIVERSITY		
DO NOT VERIFY INFORMATION BY SCALING DRAWING		DIMENSIONS ARE IN INCHES MACHINE SURFACES BREAK SHARP EDGES .005/.020	DIAGNOSTICS MAGNETIC DIAGNOSTICS MAGNETIC LOOPS SERIES "J"		
NEXT ASSEMBLY		TOLERANCES NON-CUMULATIVE DECIMAL-INCH FRACTIONS .XX +/- .000 0°-120° +/- .010 .XXX +/- .005 120°-120° +/- .010 ANGULAR +/- 0°-15° OVER 120° +/- .112	DSN: T. BROWN CHK: J. RUSHINSKI ENGR: G. LABIK SUPV: J. SIEGEL	1/12/06 1/12/06 1/12/06 1/12/06	DRAWING NO: <b>SE310-030-A.Q</b> SHEET 8 OF 15 REV 0

WEIGHT  
0.0 lbs

MODEL NAME  
SE310-030-HH7

WELDING ENGINEER

RELEASE LEVEL:  
DWG VERSION NO:

NCSX-SE310-030-A.Q



NO.	REVISION	BY	CH	SUP	APPROVED	DATE

FOR NOTES SEE SHEET 1

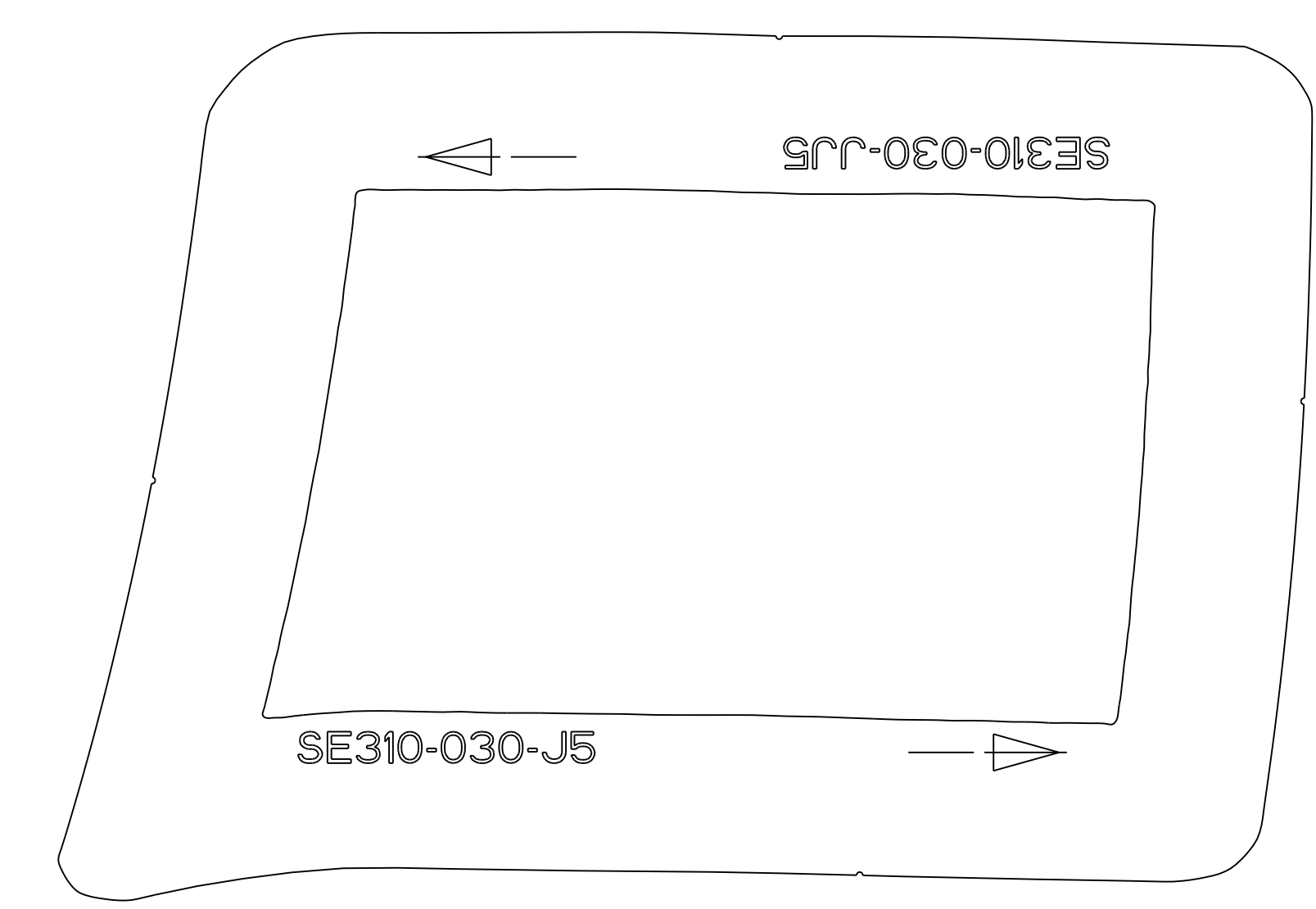

SE310-030-J5  
QNTY 1

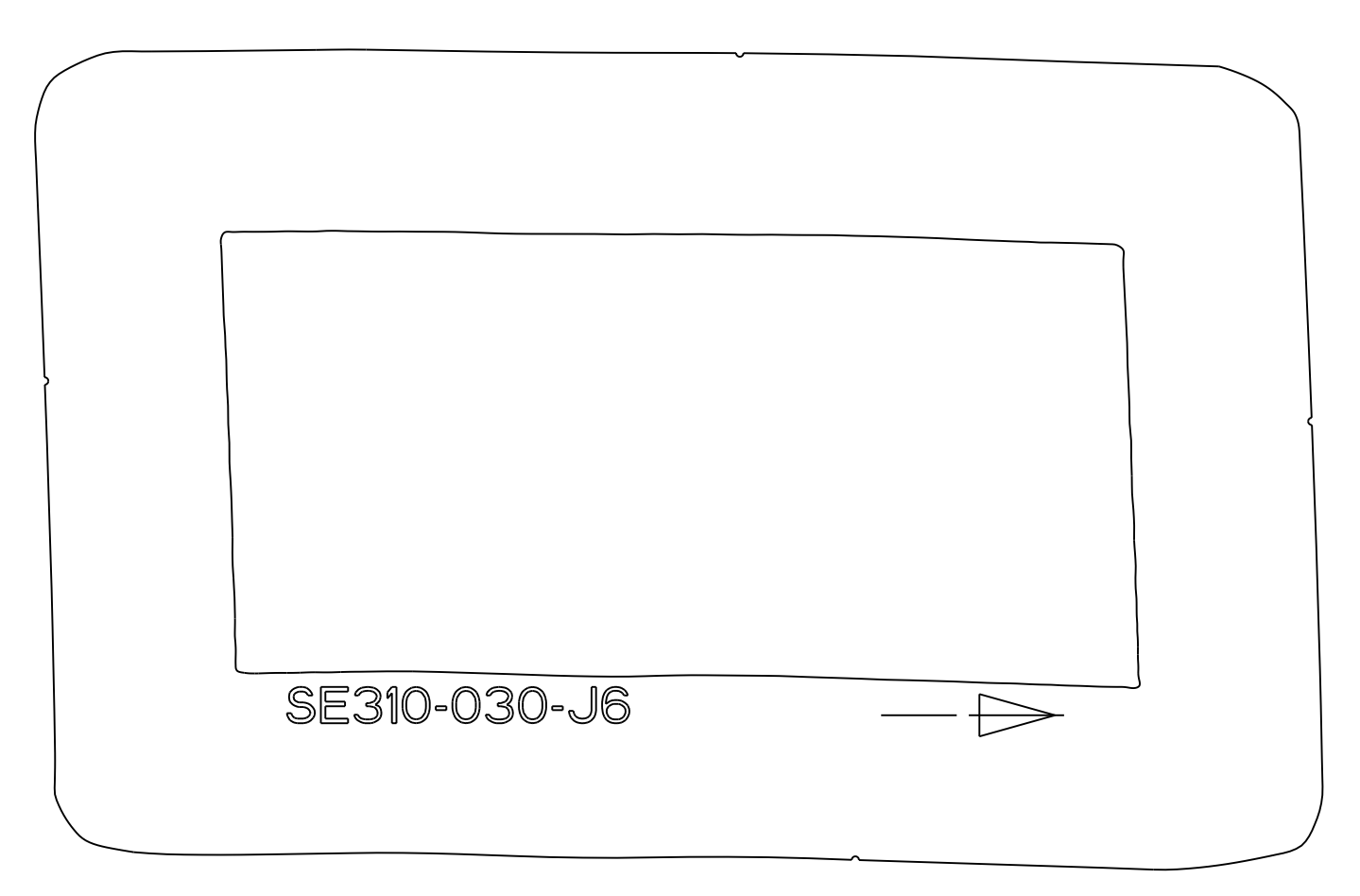

SE310-030-J6  
QNTY 1

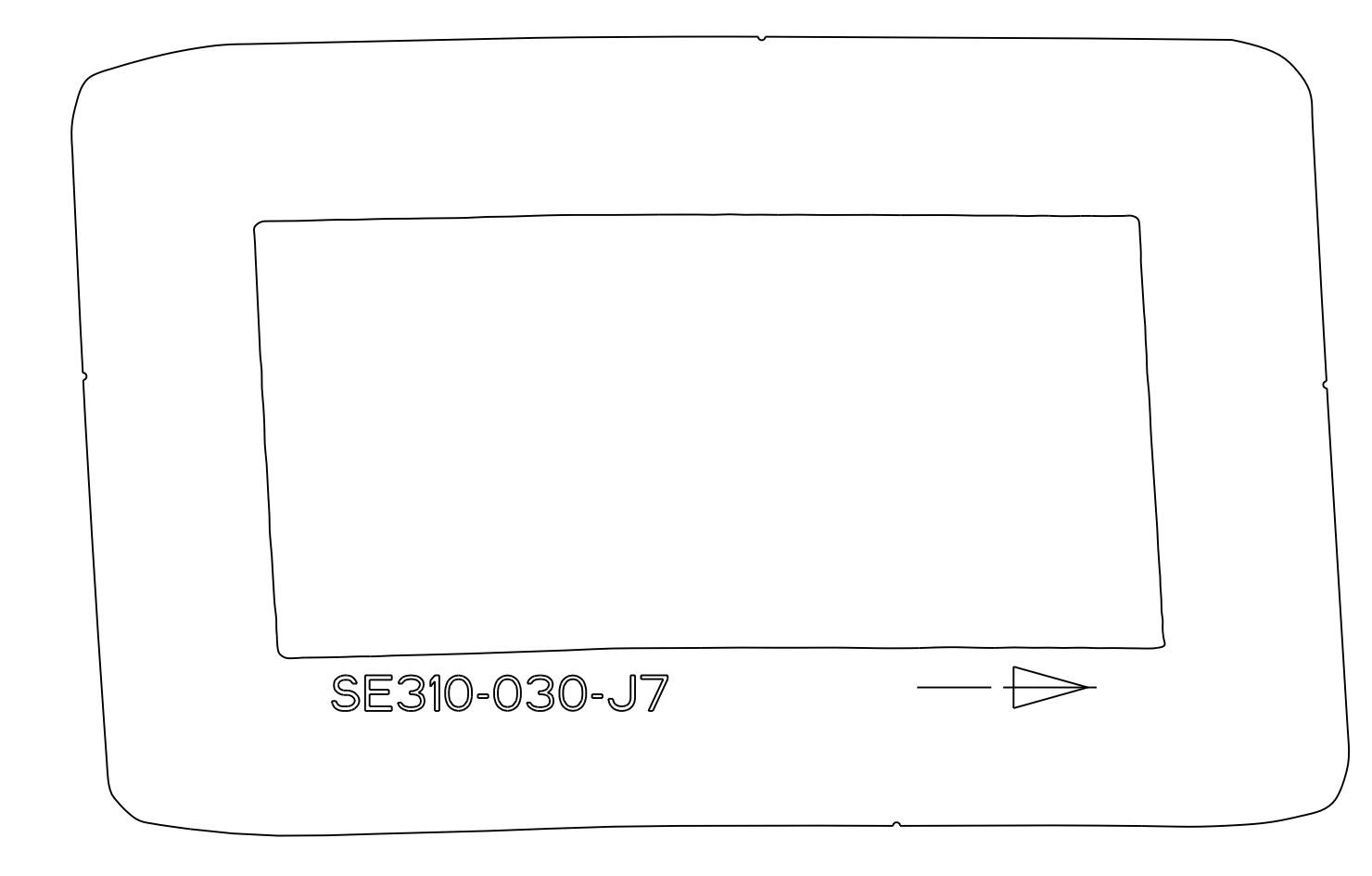

SE310-030-J7  
QNTY 1

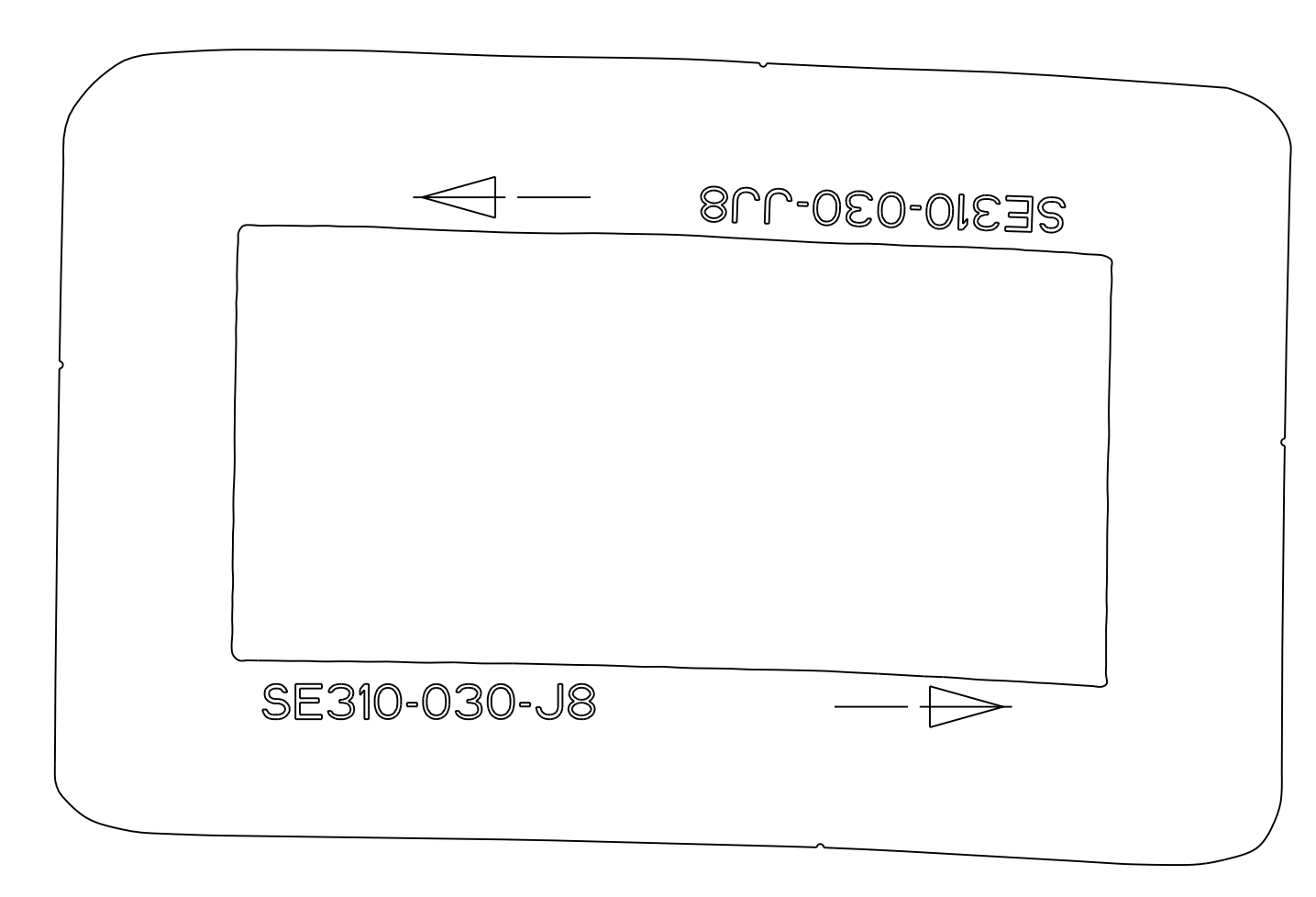

SE310-030-J8  
QNTY 1

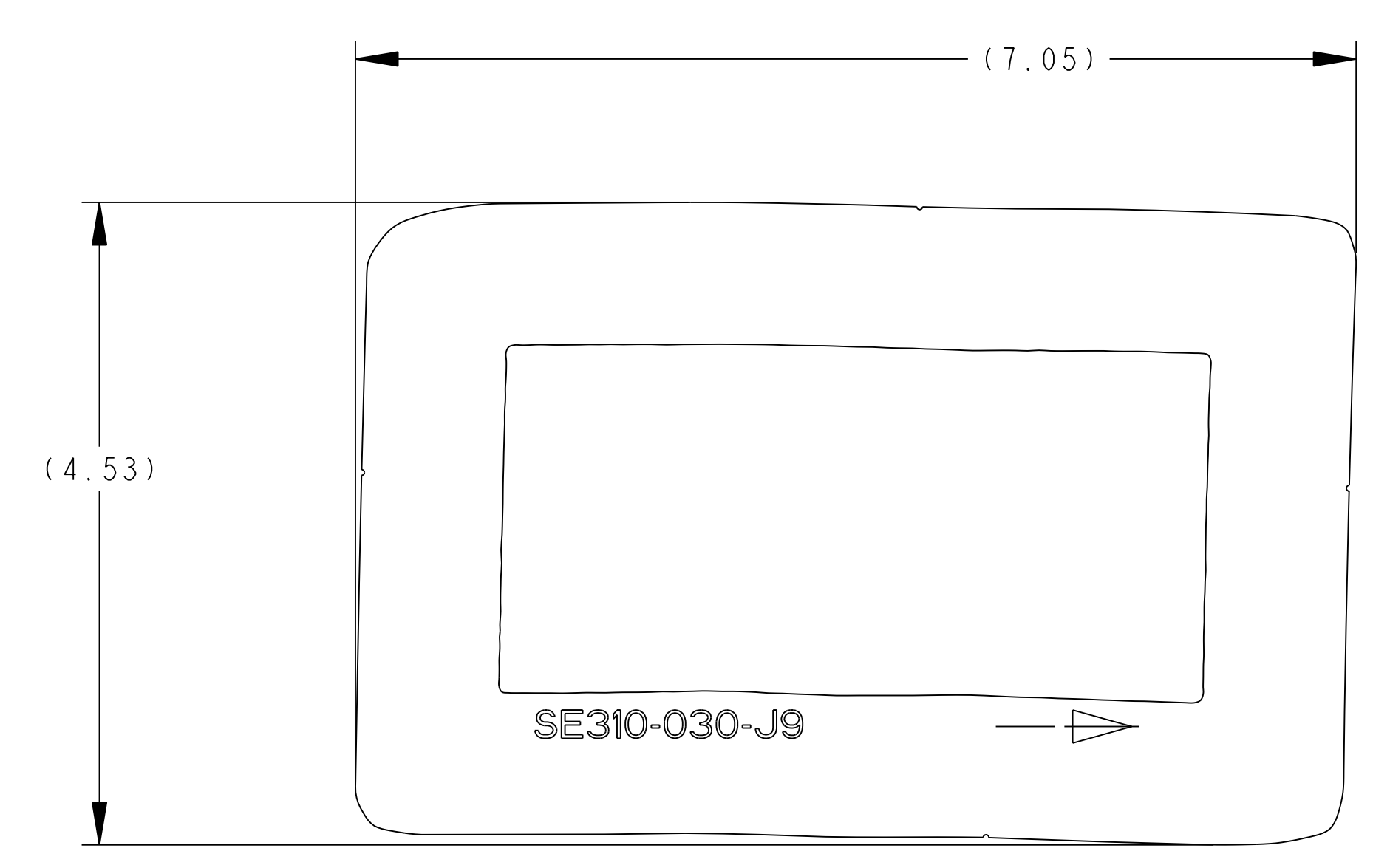

SE310-030-J9  
QNTY 1

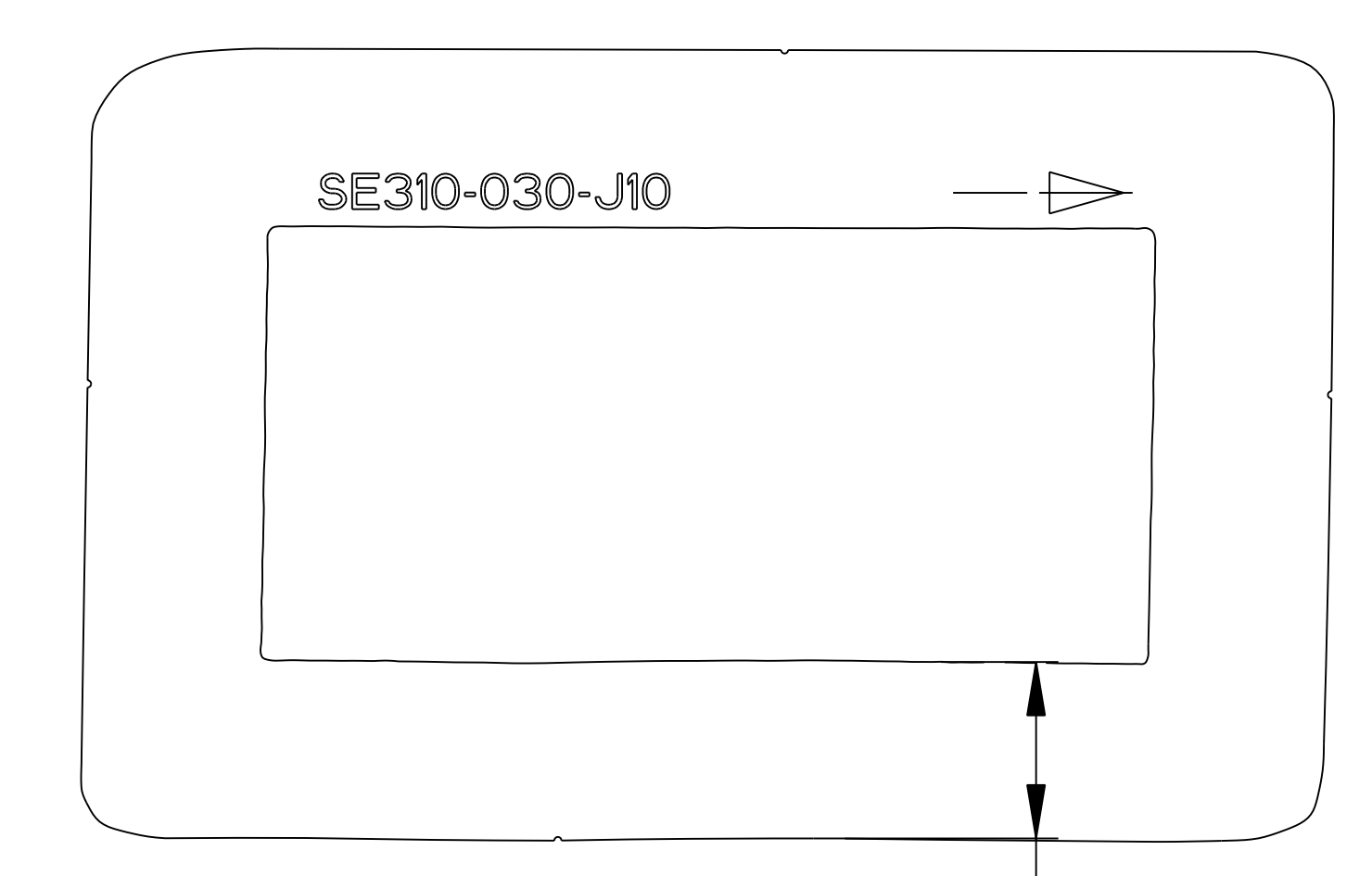

SE310-030-J10  
QNTY 1

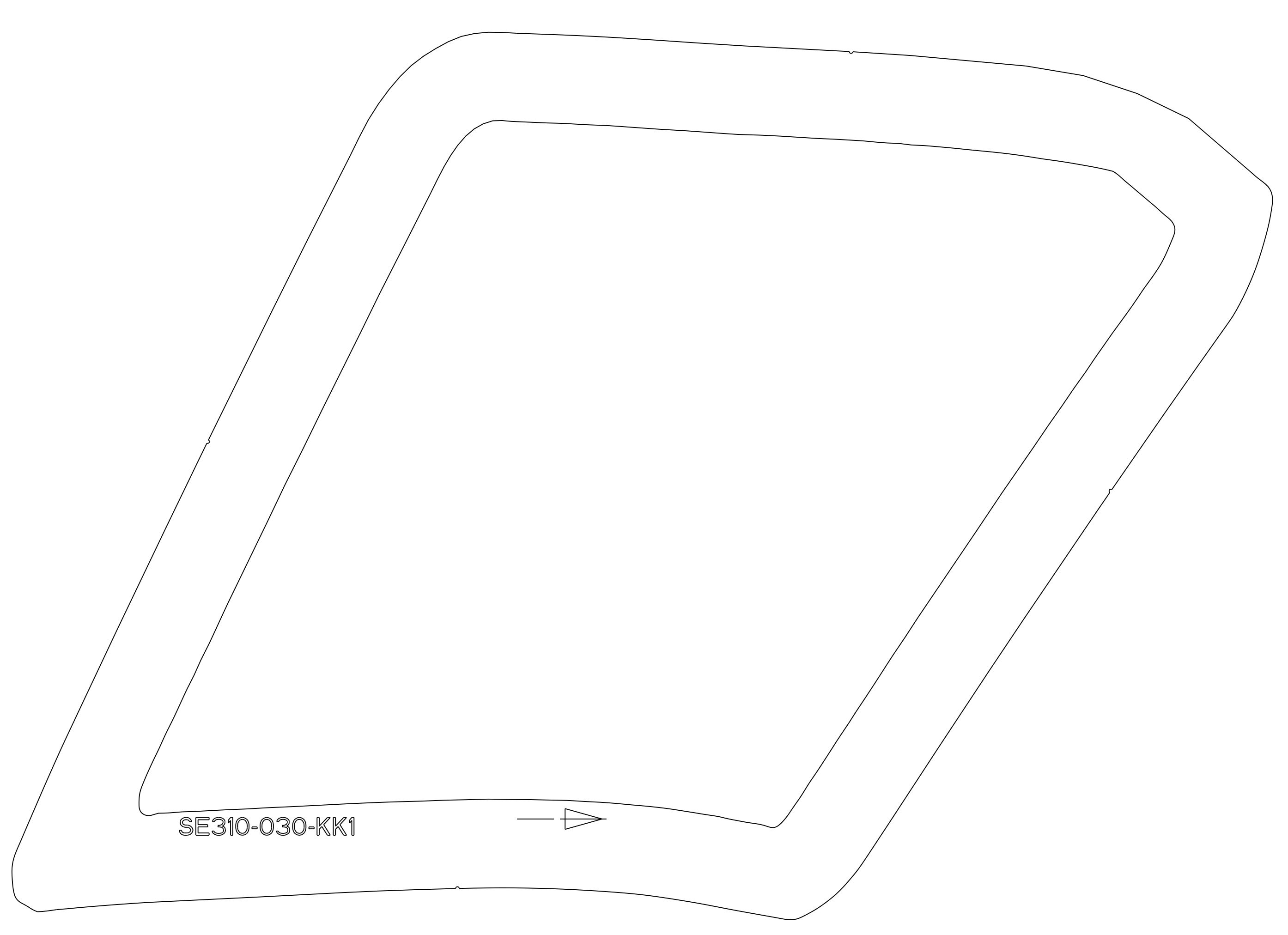

SE310-030-KK1  
QNTY 1

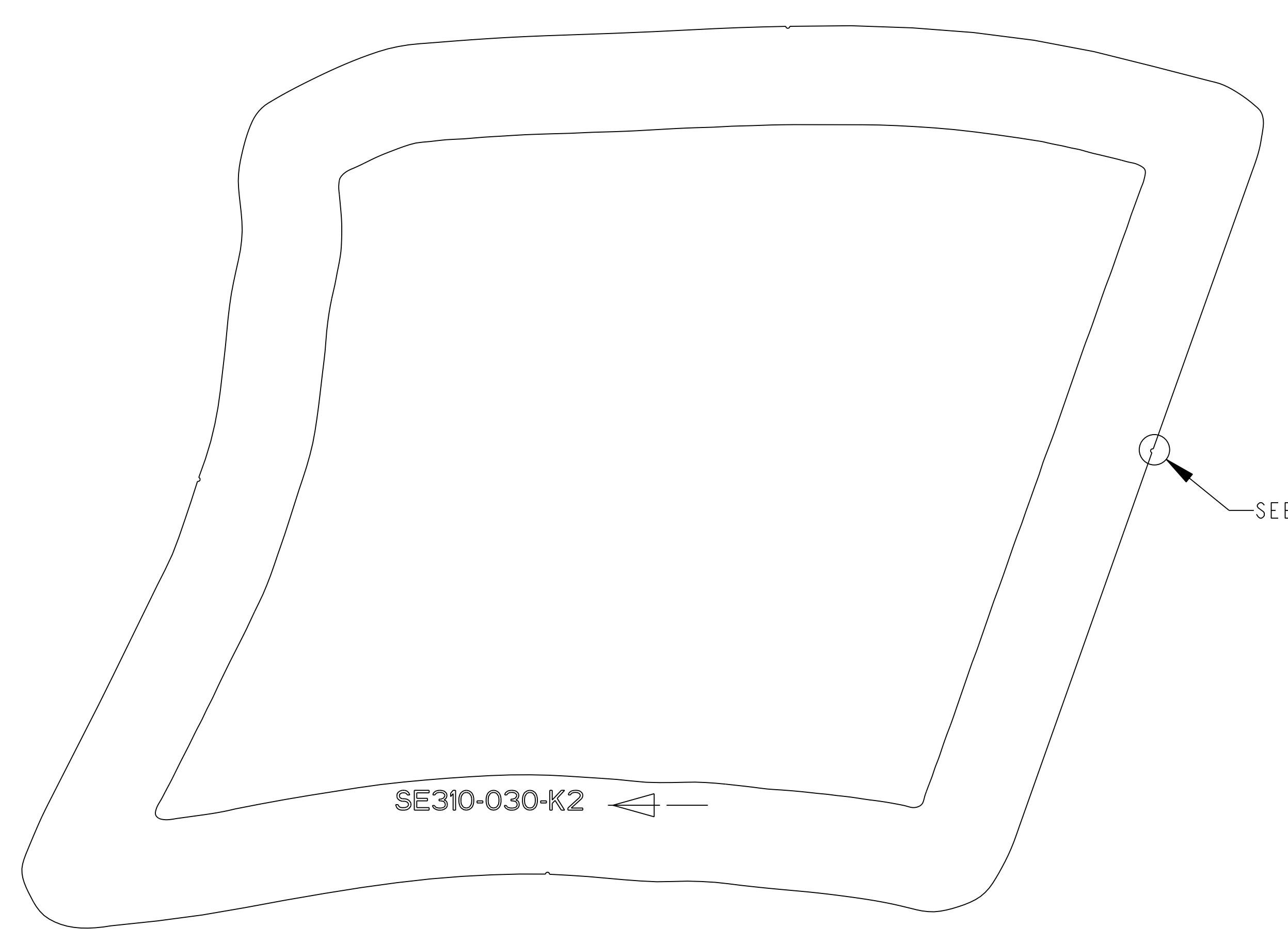

SE310-030-K2  
QNTY 1

NOTCH LOCATION AND QUANTITY VARIES BY PART  
DETAIL D  
SCALE 6.000

SEE DETAIL D

RELEASE LEVEL: WIP  
DWG VERSION NO: 8

WEIGHT	0.0 lbs
MODEL NAME	SE310-030-HH7
WELDING ENGINEER	

PART NO.	DRAWING NO.	NOMENCLATURE OR DESCRIPTION	MATERIAL	QTY RECD	SEE NOTES
		PARTS LIST			
COMPUTER GENERATED DRAWING CHANGES NOT PERMITTED		CENTRAL FILES: UNLESS OTHERWISE SPECIFIED	PRINCETON PLASMA PHYSICS LABORATORY		
DO NOT VERIFY INFORMATION BY SCALING DRAWING		DIMENSIONS ARE IN INCHES MACHINE SURFACES	NATIONAL COMPACT STELLARATOR EXPERIMENT		
NEXT ASSEMBLY		TOLERANCES NON-CUMULATIVE	DIAGNOSTICS MAGNETIC DIAGNOSTICS MAGNETIC LOOPS SERIES "J AND K"		
		DECIMAL-INCH FRACTIONS	DSN: T. BROWN	1/12/06	DRAWING NO:
		.XX +/- .030 12°-12° +/- 1/8	CHK: J. RUSHINSKI	1/12/06	SE310-030-A.Q
		.XXX +/- .005 72°-120° +/- 1/4 ANGULAR +/- 0°-15° OVER 120° +/- 1/2	ENGR: G. LABIK	1/12/06	SHEET 9 OF 15
			SUPV: J. SIEGEL	1/12/06	REV 0

NCSX-SE310-030-A.Q

NO.	REVISION	BY	CH	SUP	APPROVED	DATE

FOR NOTES SEE SHEET 1

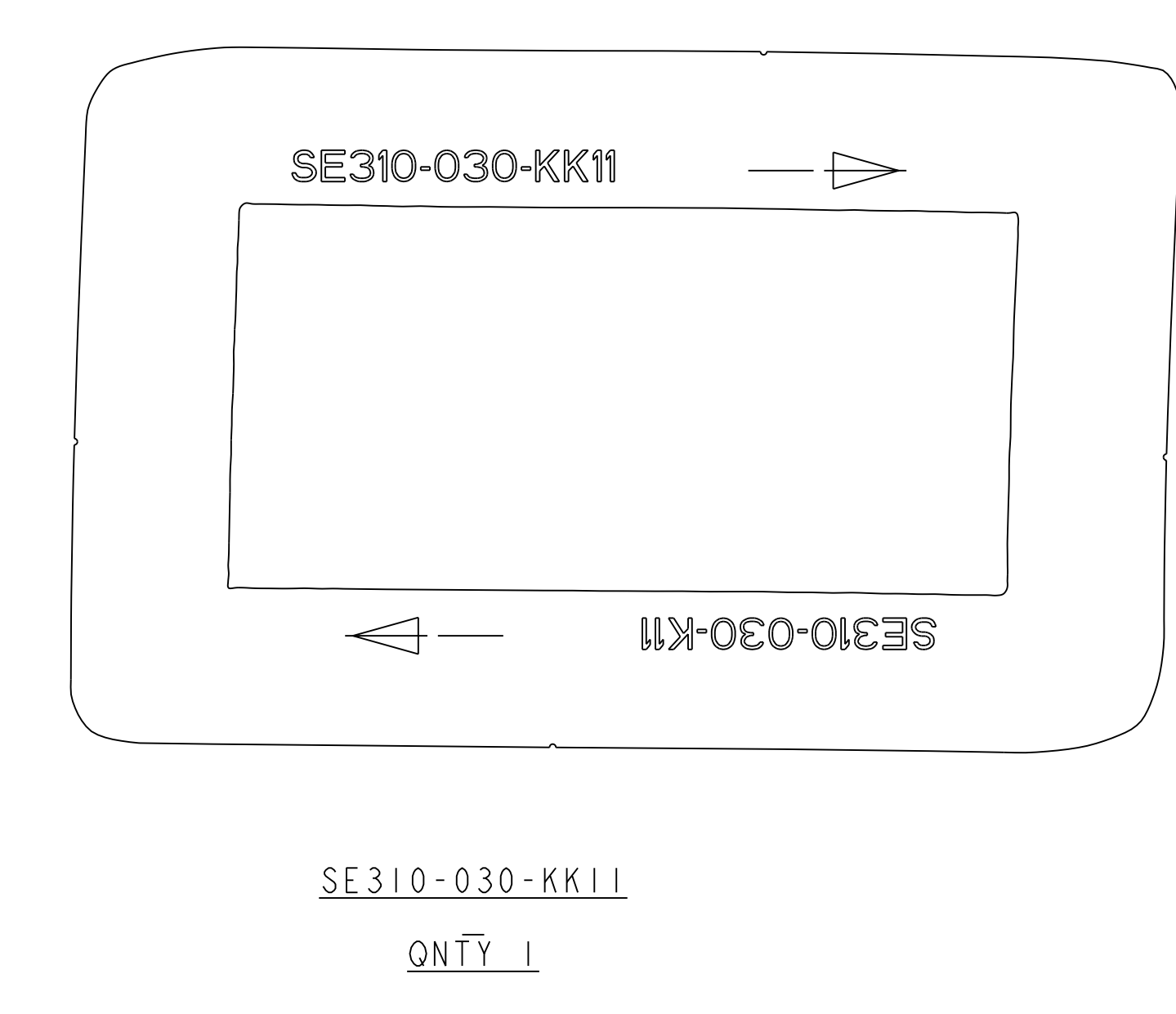
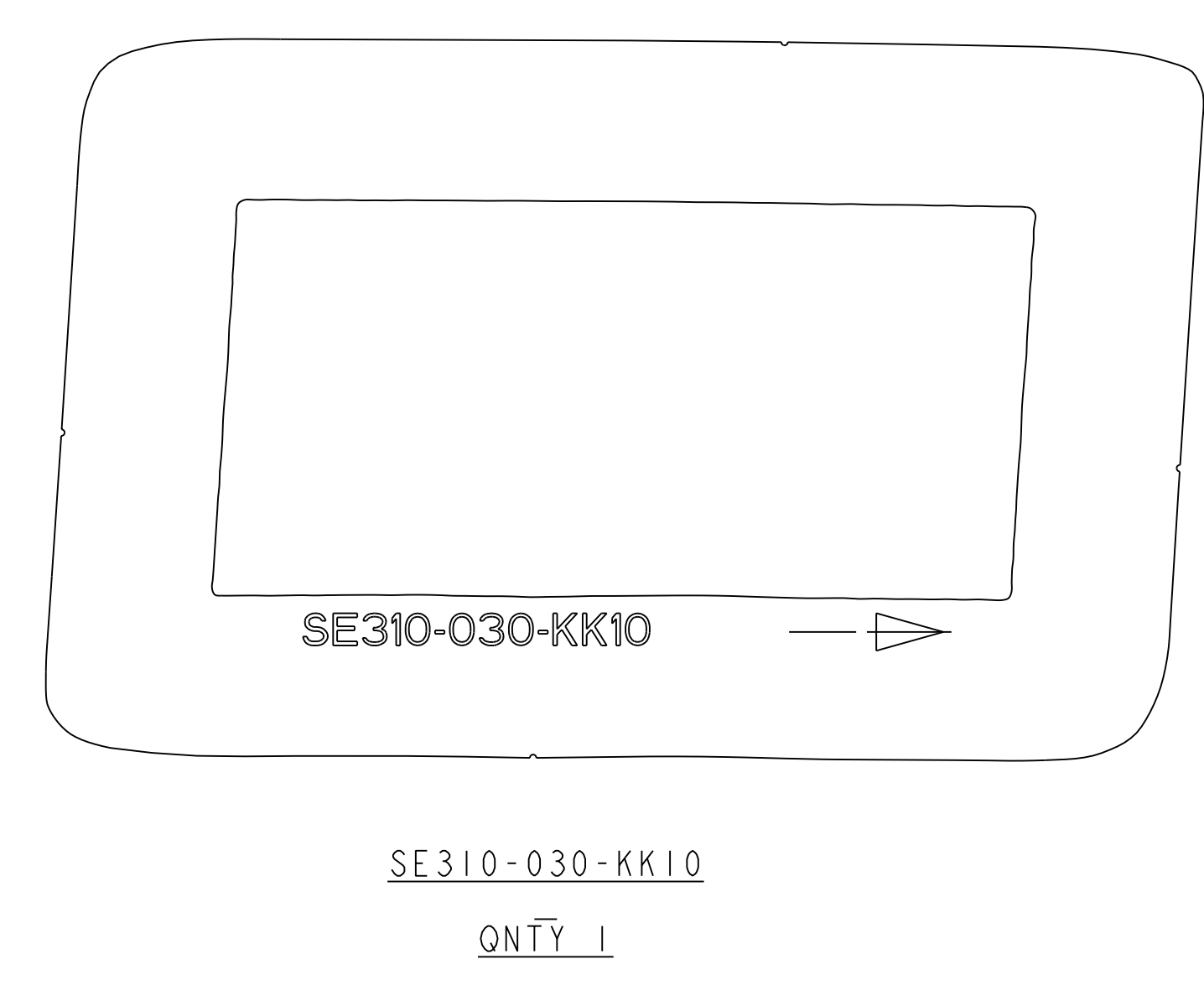
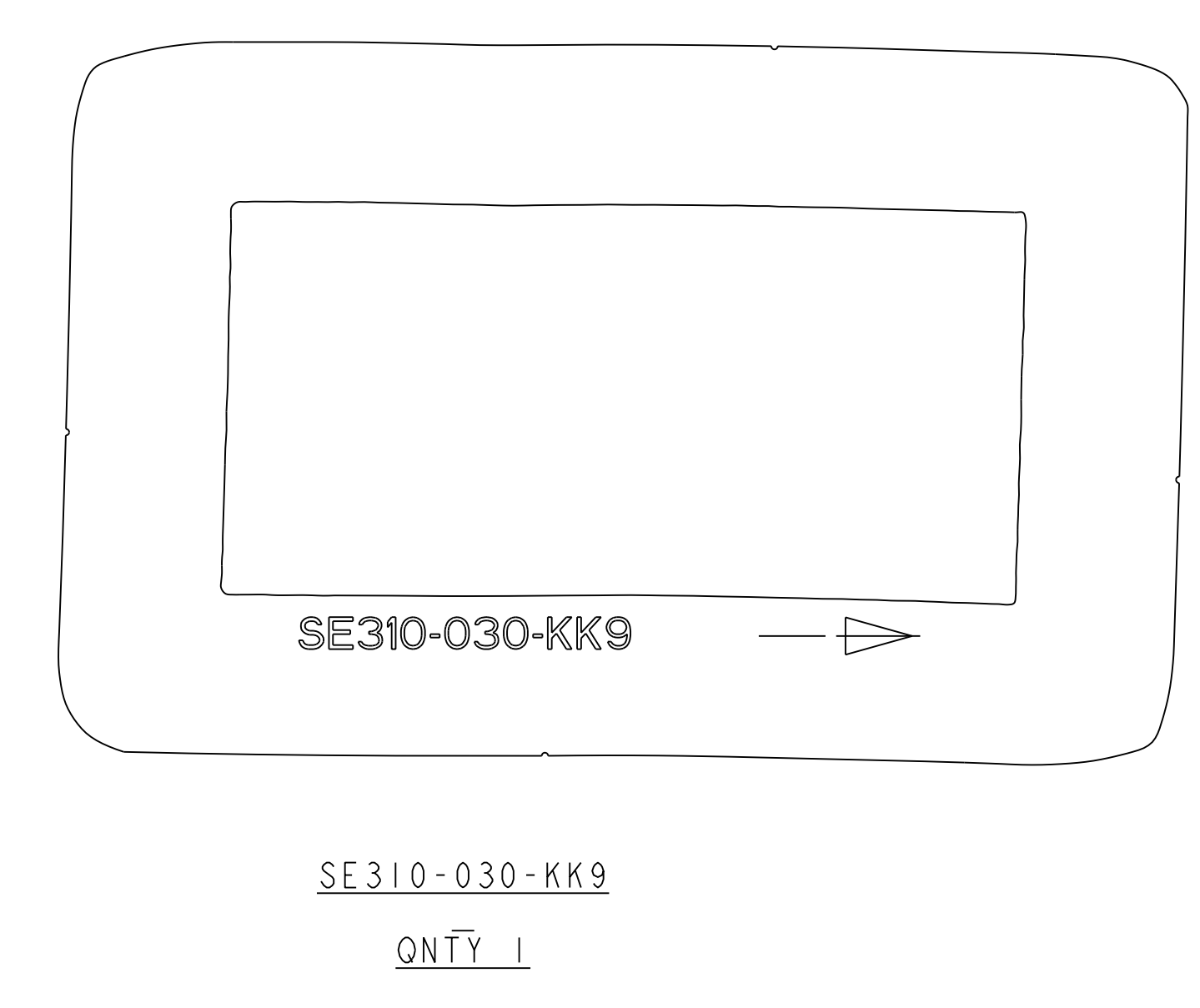
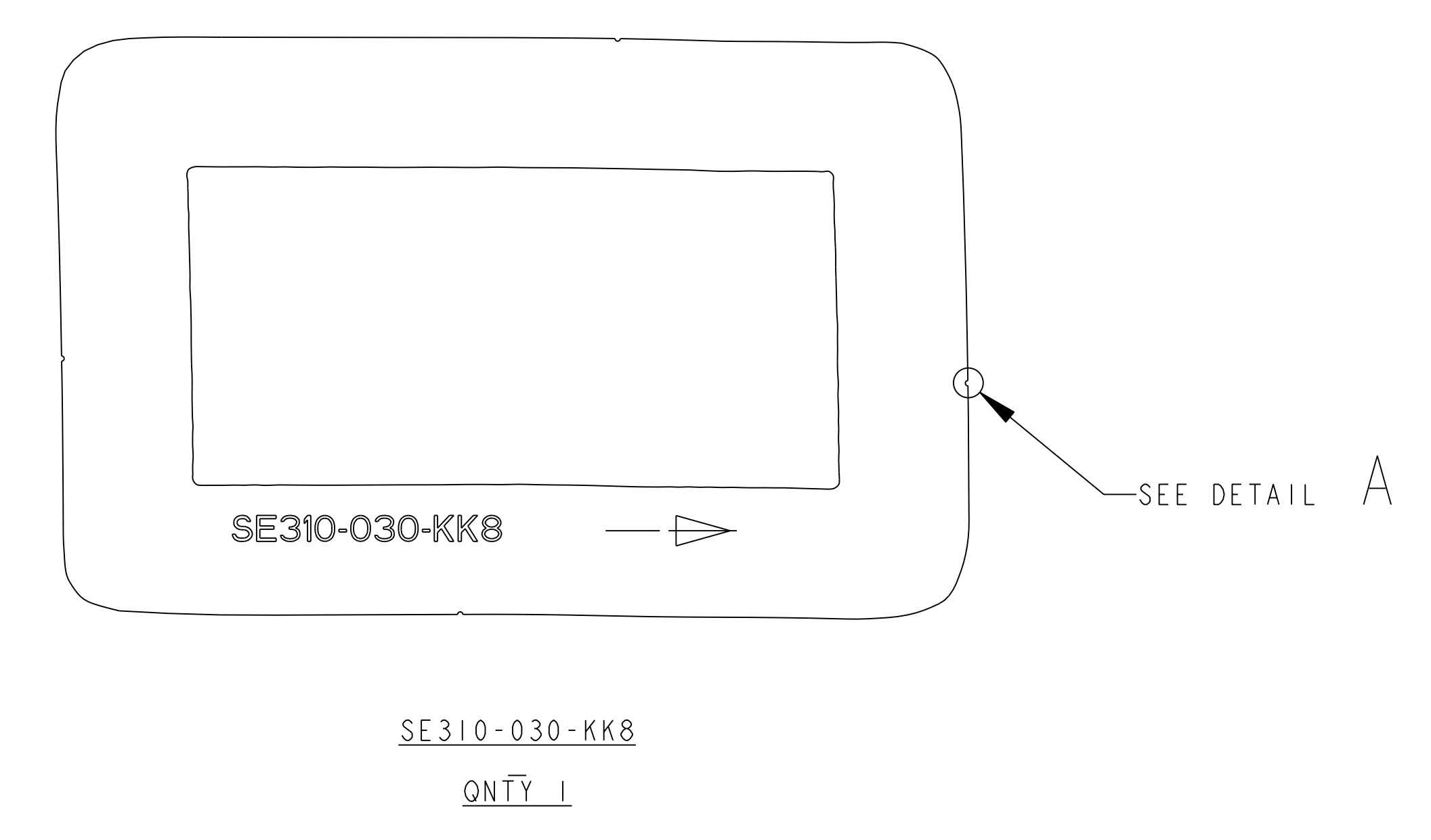
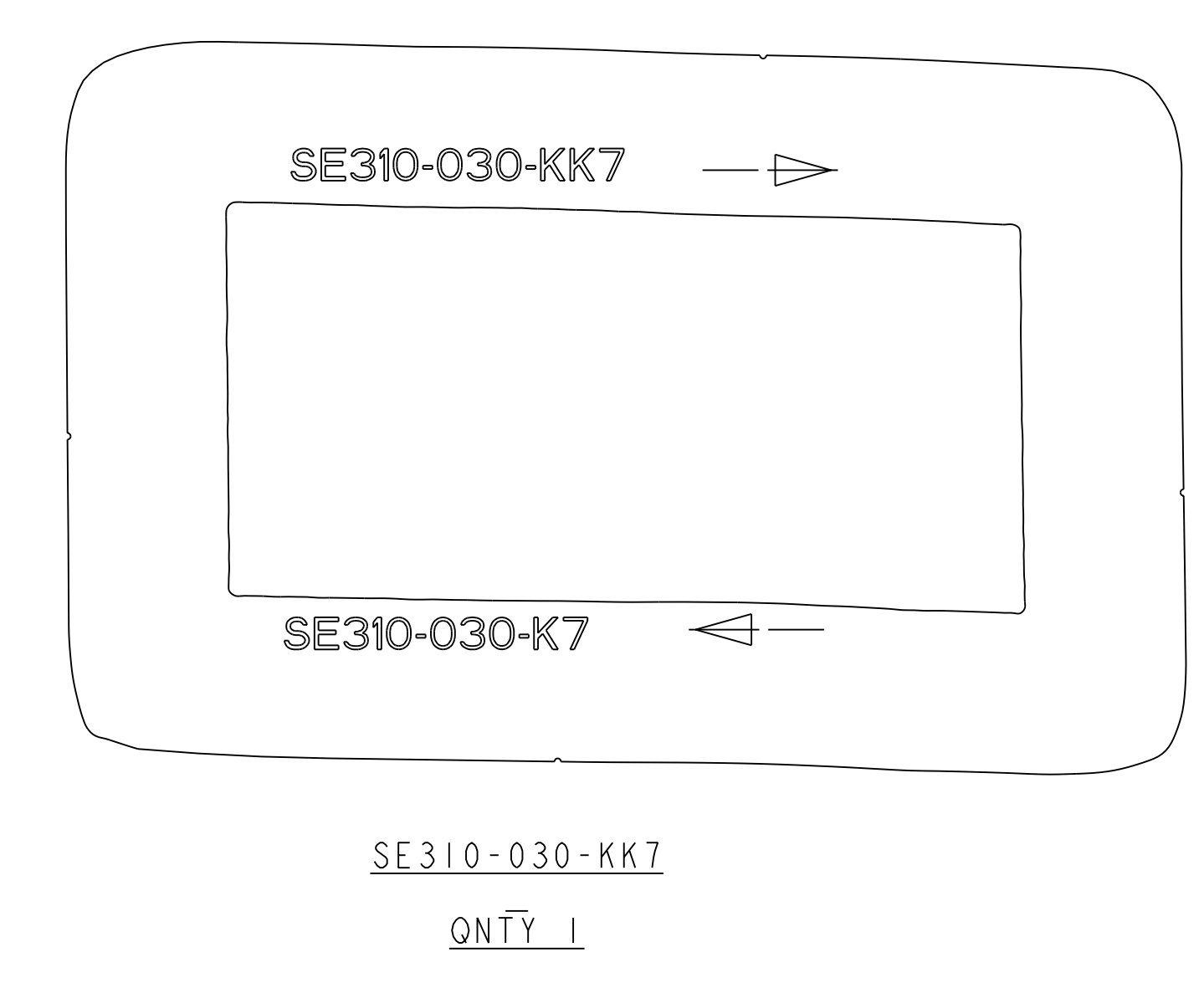
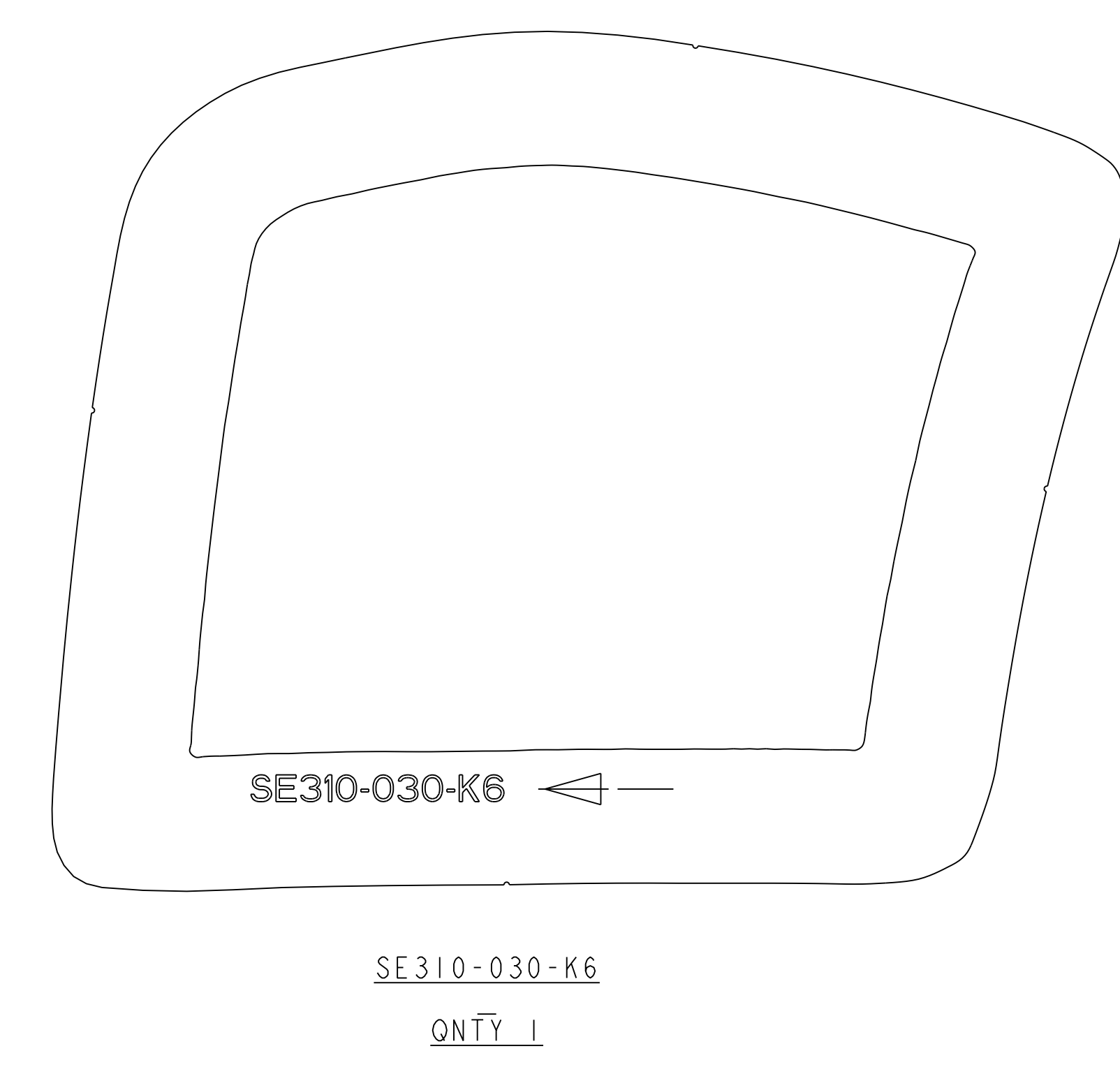
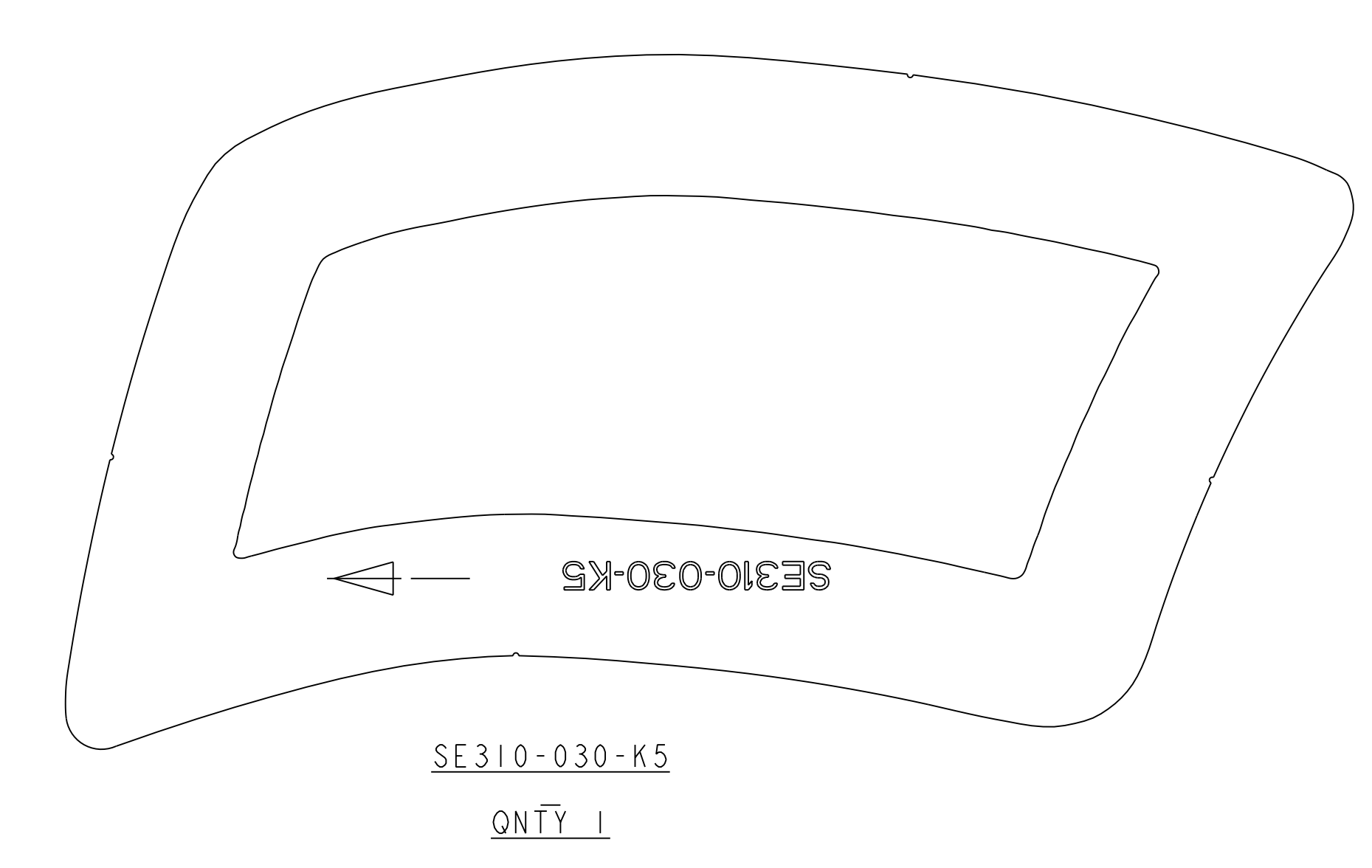
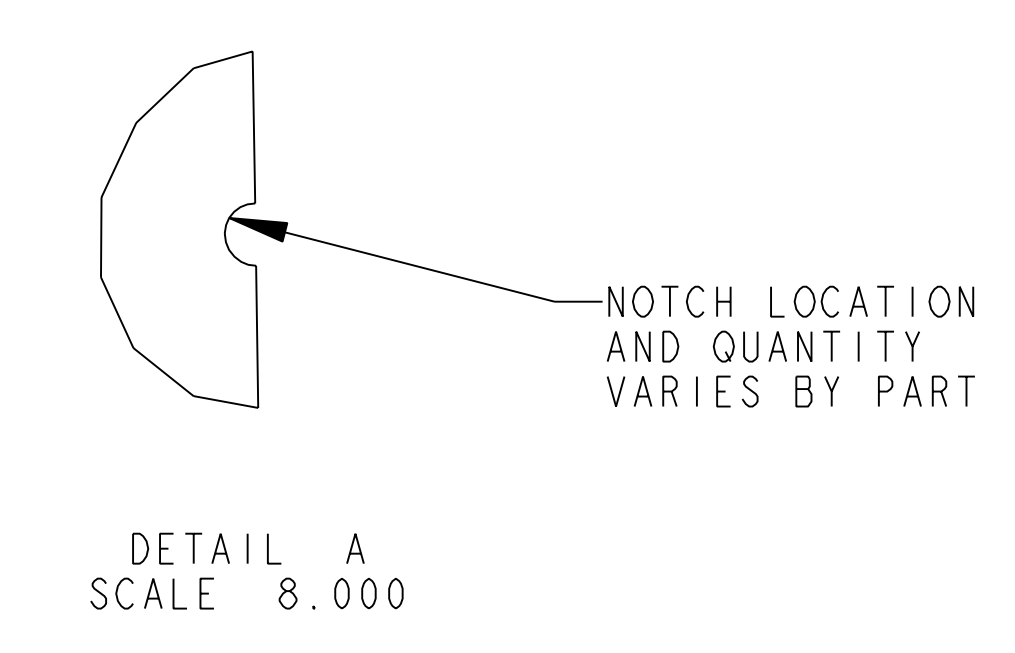
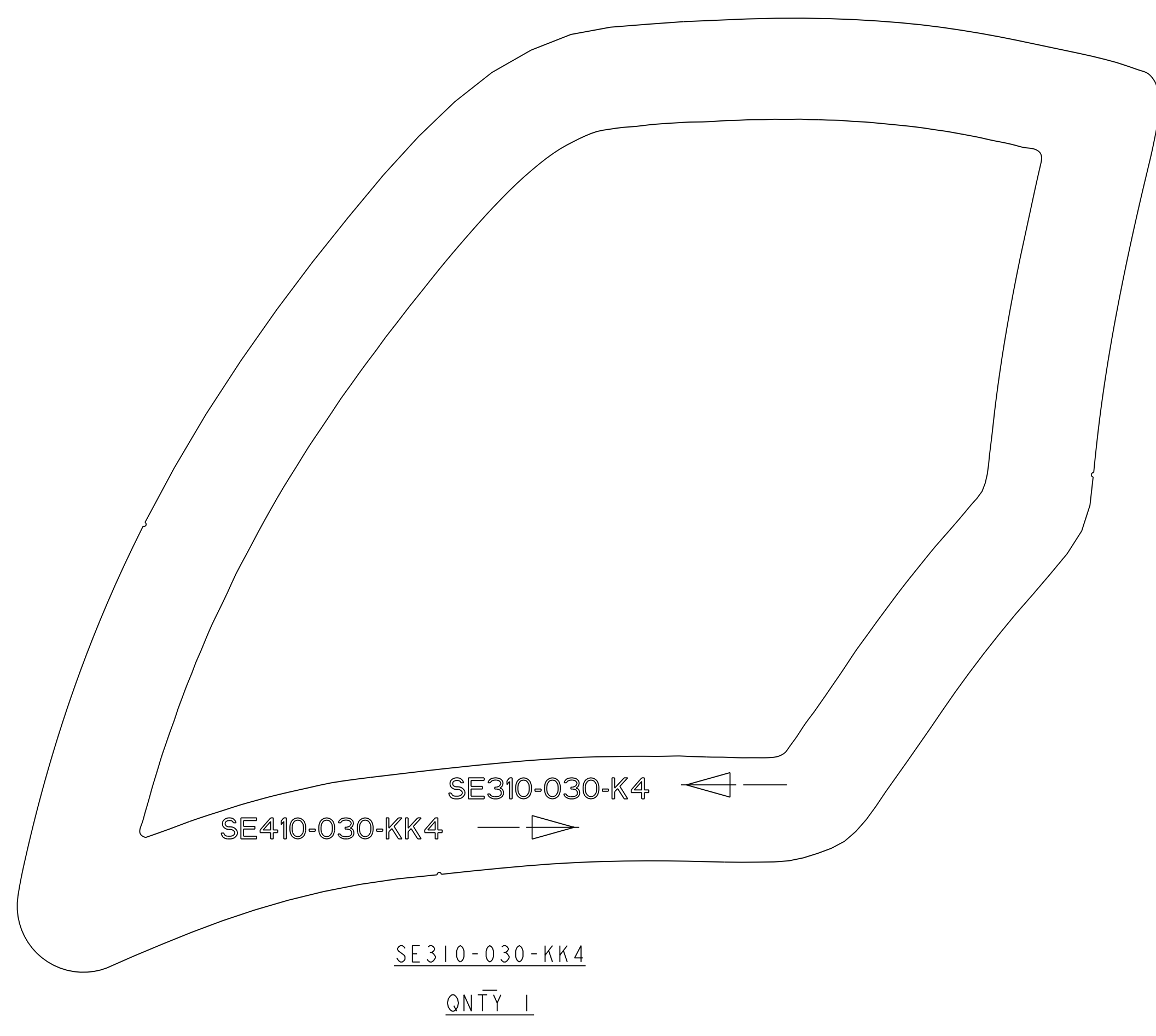
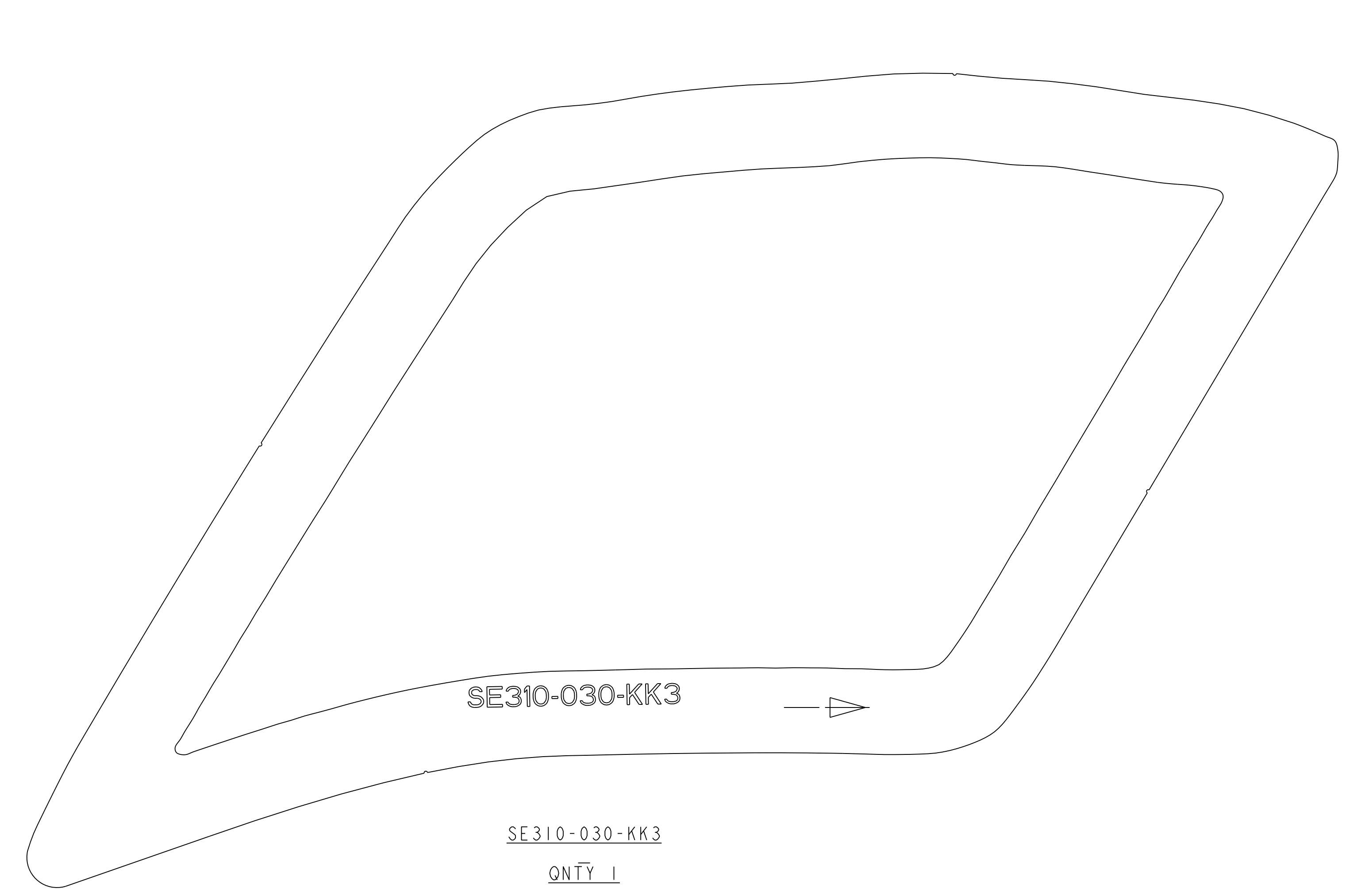

RELEASE LEVEL:  
DWG VERSION NO:

WEIGHT  
0.0 lbs  
MODEL NAME  
SE310-030-HH7  
WELDING  
ENGINEER

PART NO.	DRAWING NO	NOMENCLATURE OR DESCRIPTION	MATERIAL	QTY REOD
PARTS LIST				
COMPUTER GENERATED DRAWING DRAWING CHANGES NOT PERMITTED Pro E		CENTRAL FILES: UNLESS OTHERWISE SPECIFIED DIMENSIONS ARE IN INCHES MACHINE SURFACES BREAK SHARP EDGES .005/.020	PRINCETON PLASMA PHYSICS LABORATORY PRINCETON UNIVERSITY NATIONAL COMPACT STELLARATOR EXPERIMENT DIAGNOSTICS MAGNETIC DIAGNOSTICS MAGNETIC LOOPS SERIES "K"	
DO NOT VERIFY INFORMATION BY SCALING DRAWING	TOLERANCES NON-CUMULATIVE	DSN: T. BROWN	1/12/06	DRAWING NO:
NEXT ASSEMBLY	DECIMAL-INCH FRACTIONS	CHK: J. RUSHINSKI	1/12/06	<b>SE310-030-A.Q</b>
	.XX +/- .000 0°-12° +/- .004	ENGR: G. LABIK	1/12/06	SHEET 1 OF 15
	.XXX +/- .005 12°-120° +/- .004	SUPV: J. SIEGEL	1/12/06	REV 0
	ANGULAR +/- .0°-15° OVER 120° +/- .002			

NCSX-SE310-030-A.Q

NO.	REVISION	BY	CH	SUP	APPROVED	DATE

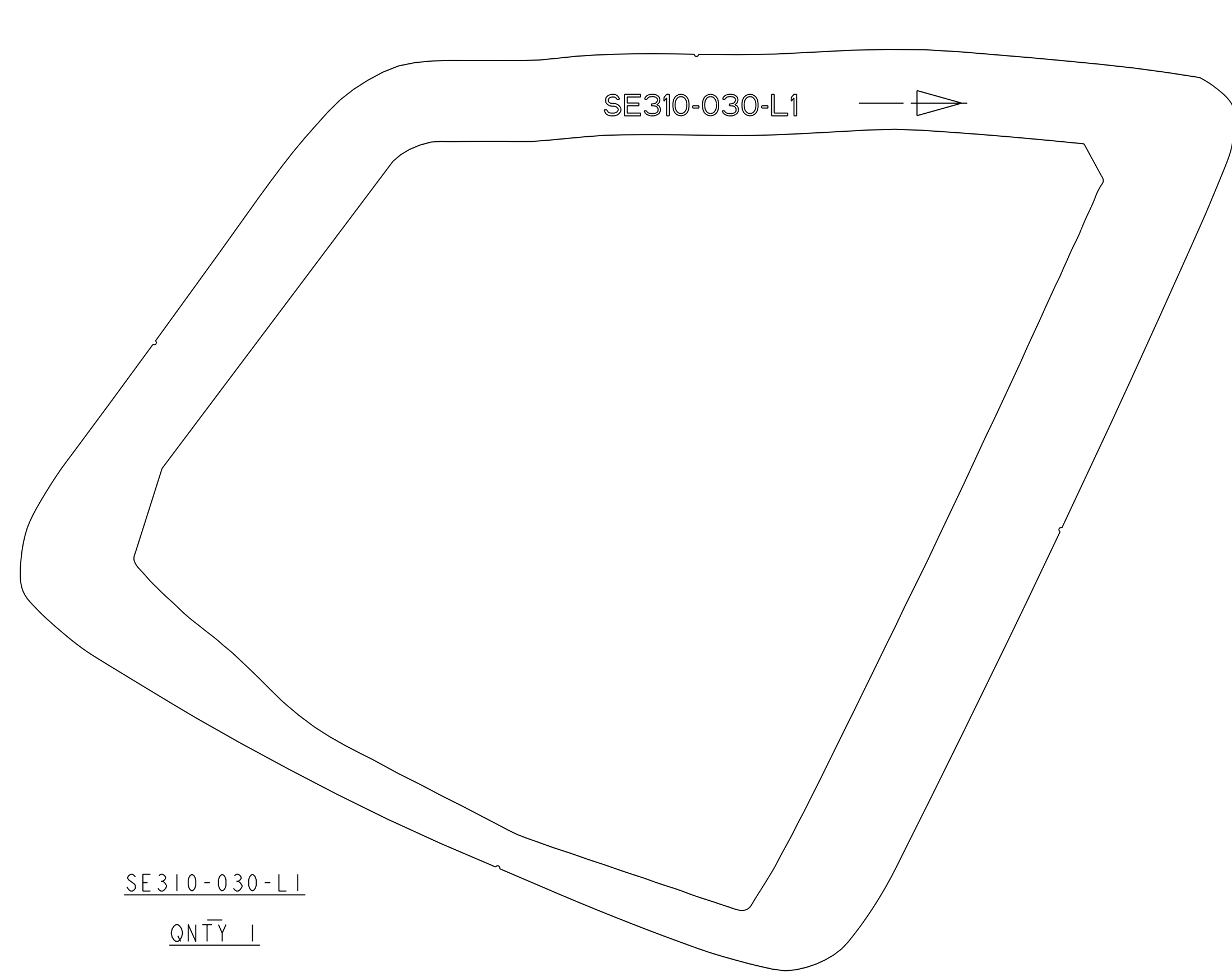

SE310-030-L1  
QNTY 1

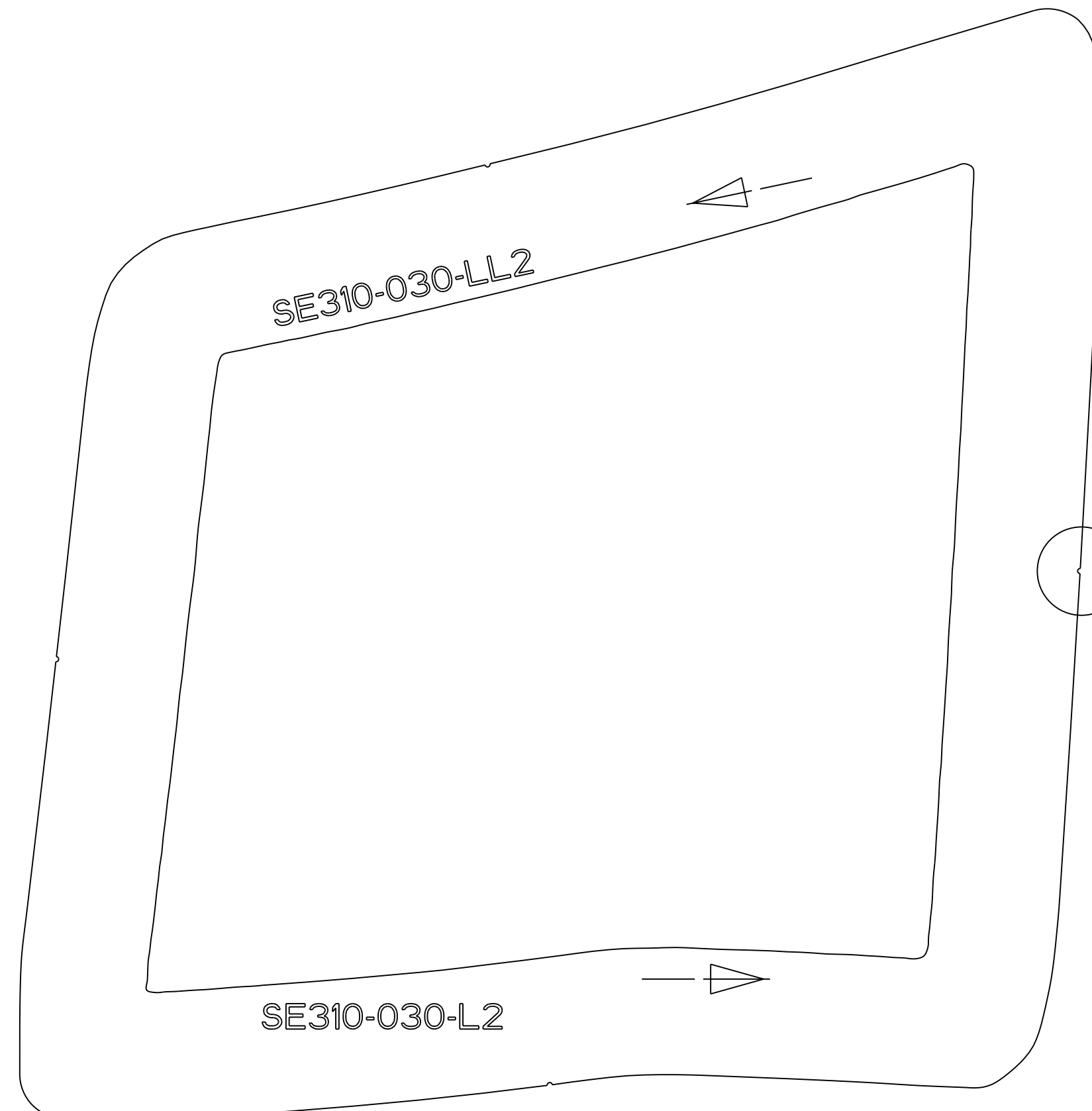

SE310-030-L2  
QNTY 1

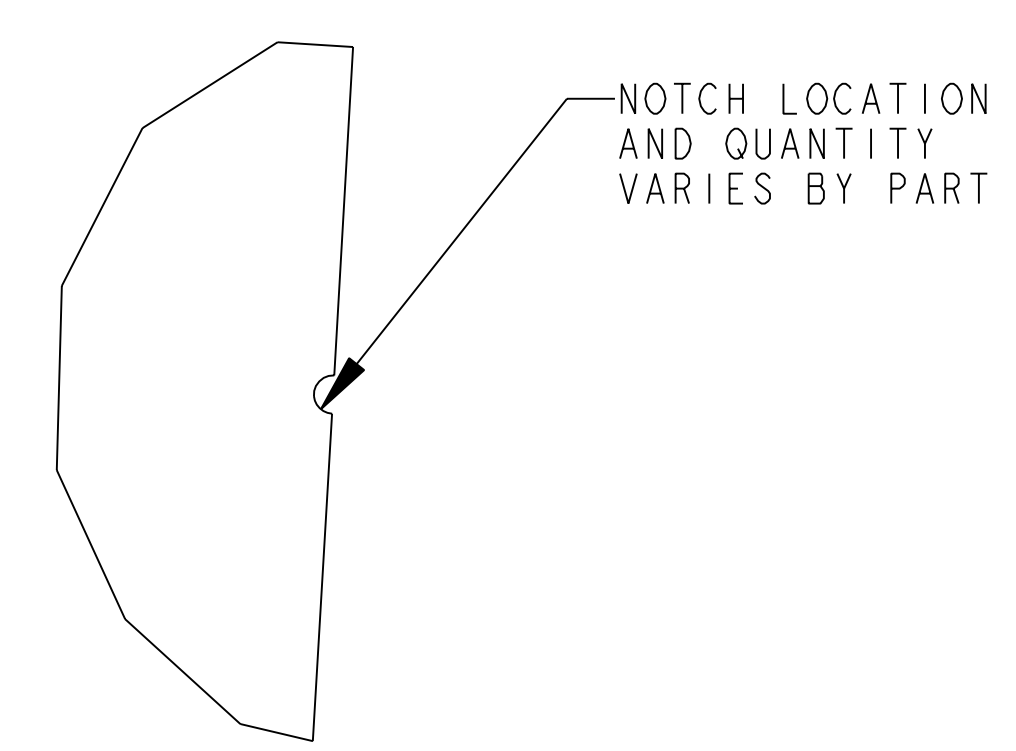

DETAIL A  
SCALE 5.000

SEE DETAIL A

FOR NOTES SEE SHEET 1

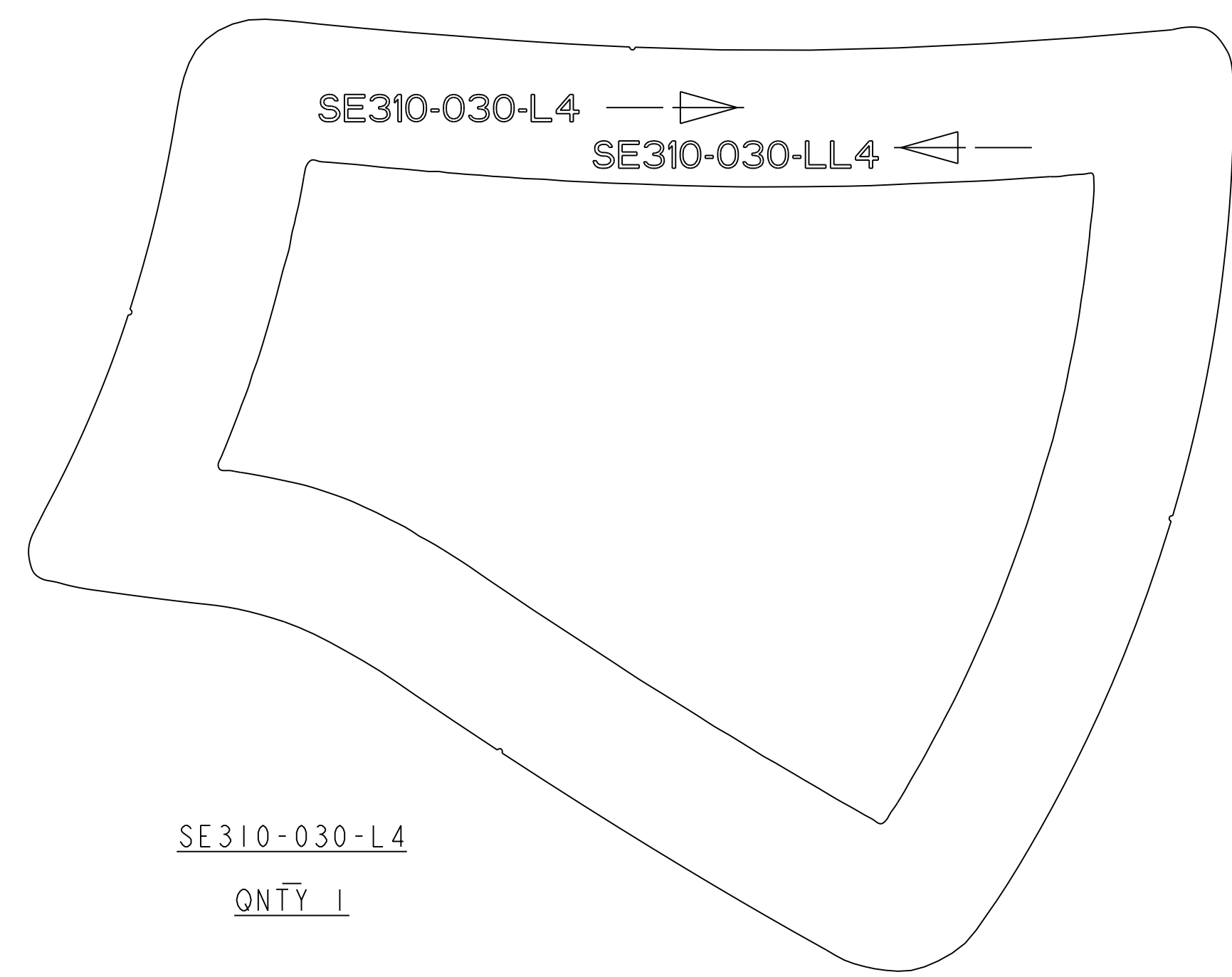

SE310-030-L4  
QNTY 1

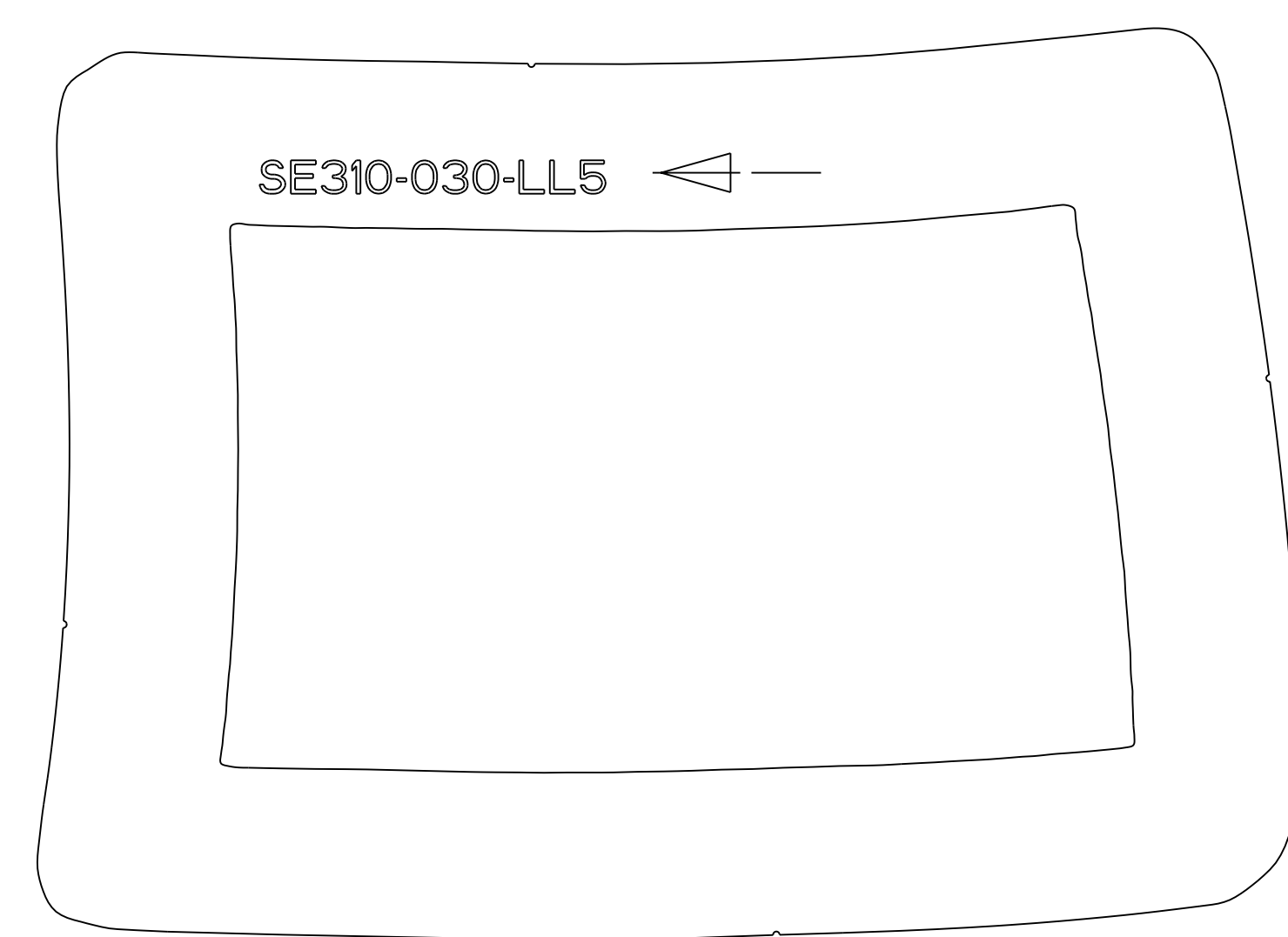

SE310-030-LL5  
QNTY 1

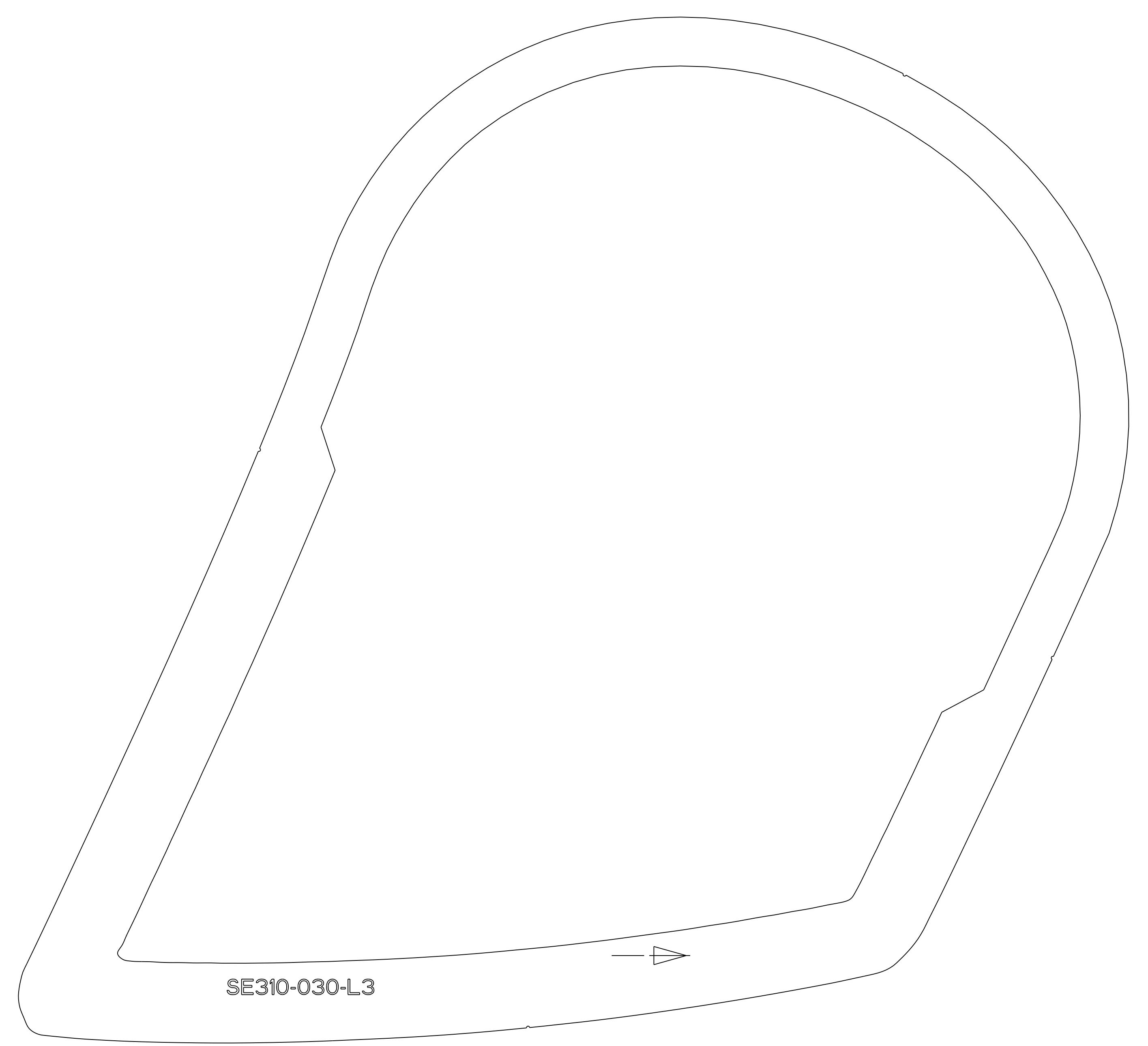

SE310-030-L3  
QNTY 1

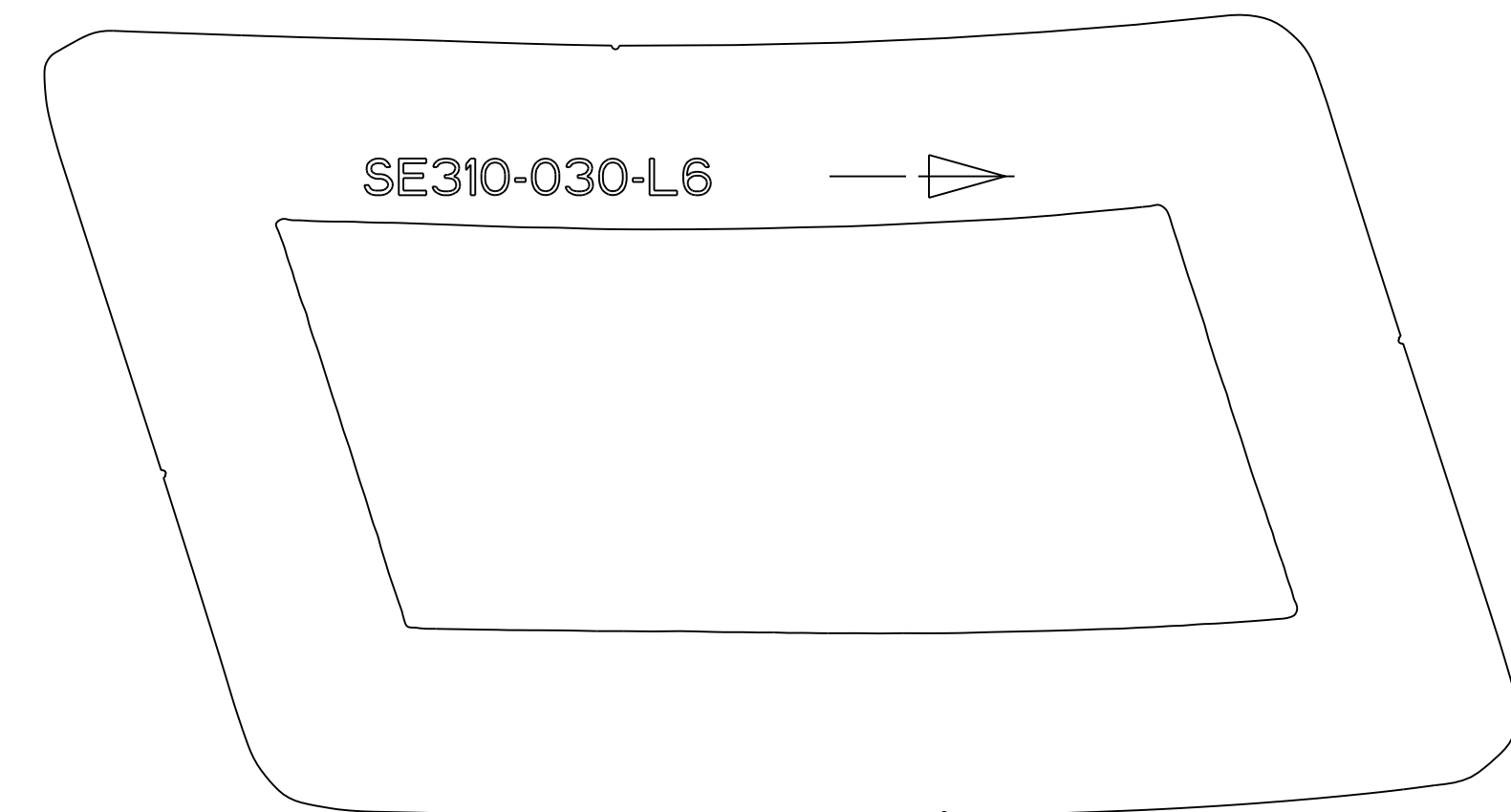

SE310-030-L6  
QNTY 1

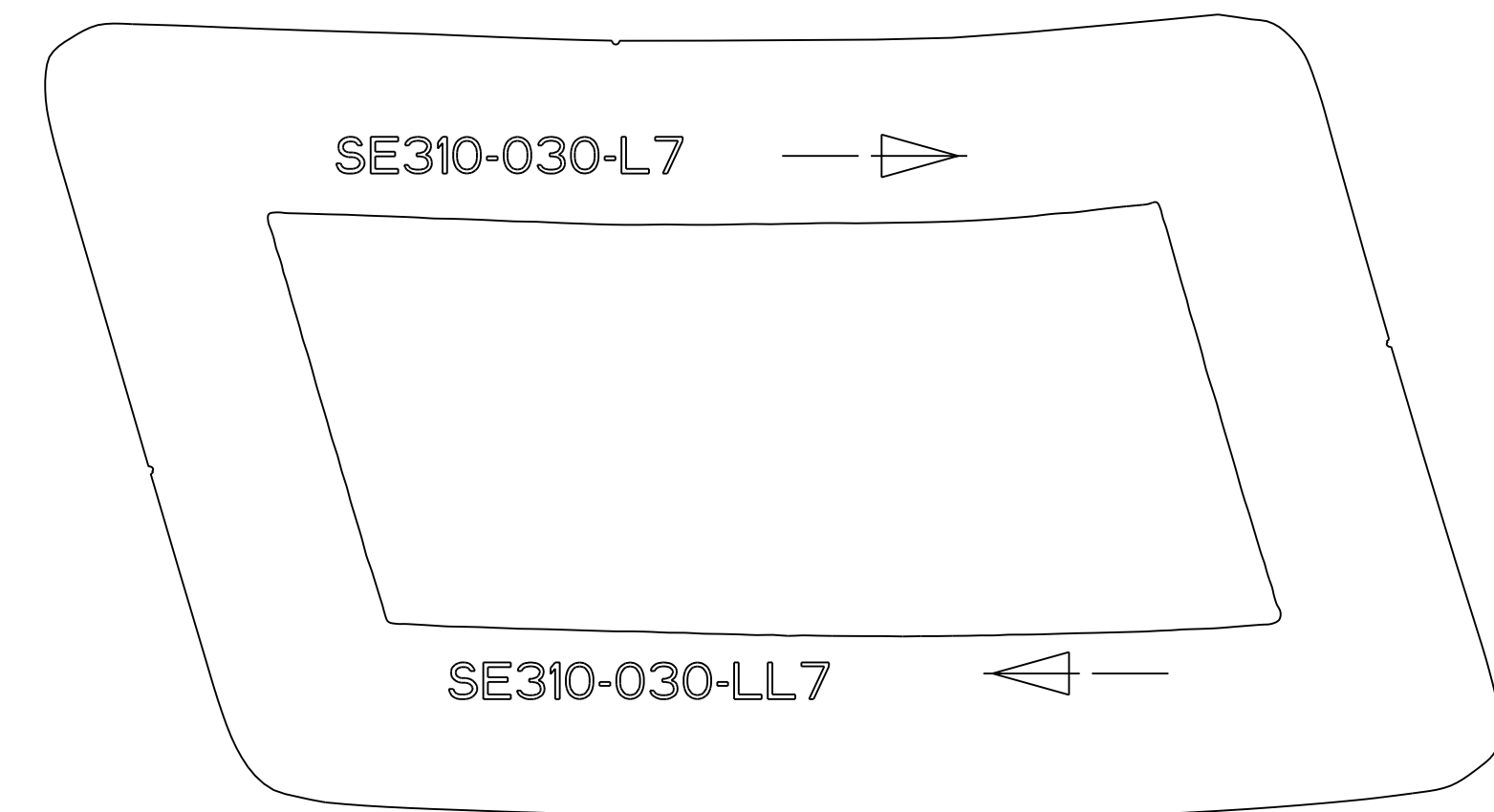

SE310-030-L7  
QNTY 2

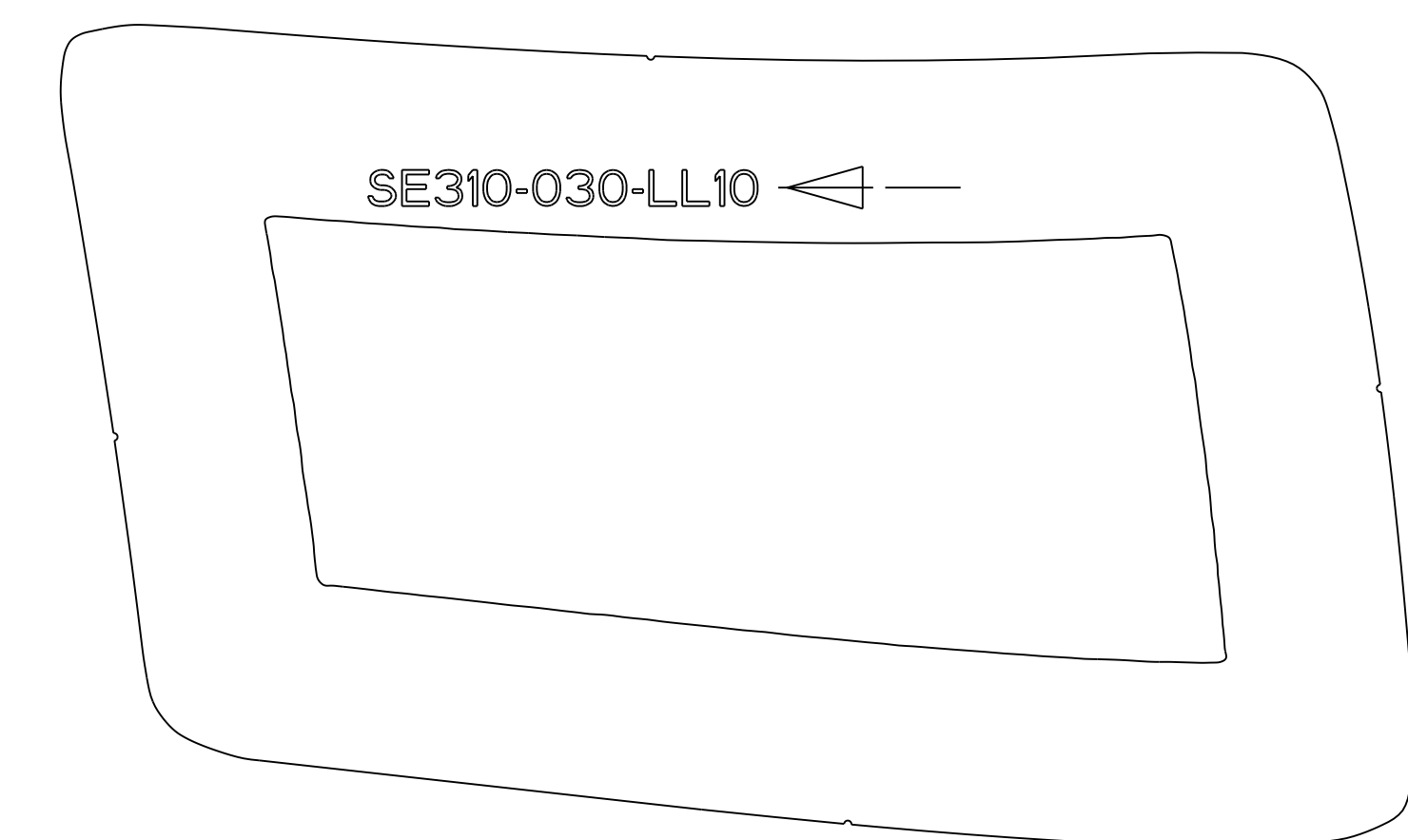

SE310-030-LL10  
QNTY 1

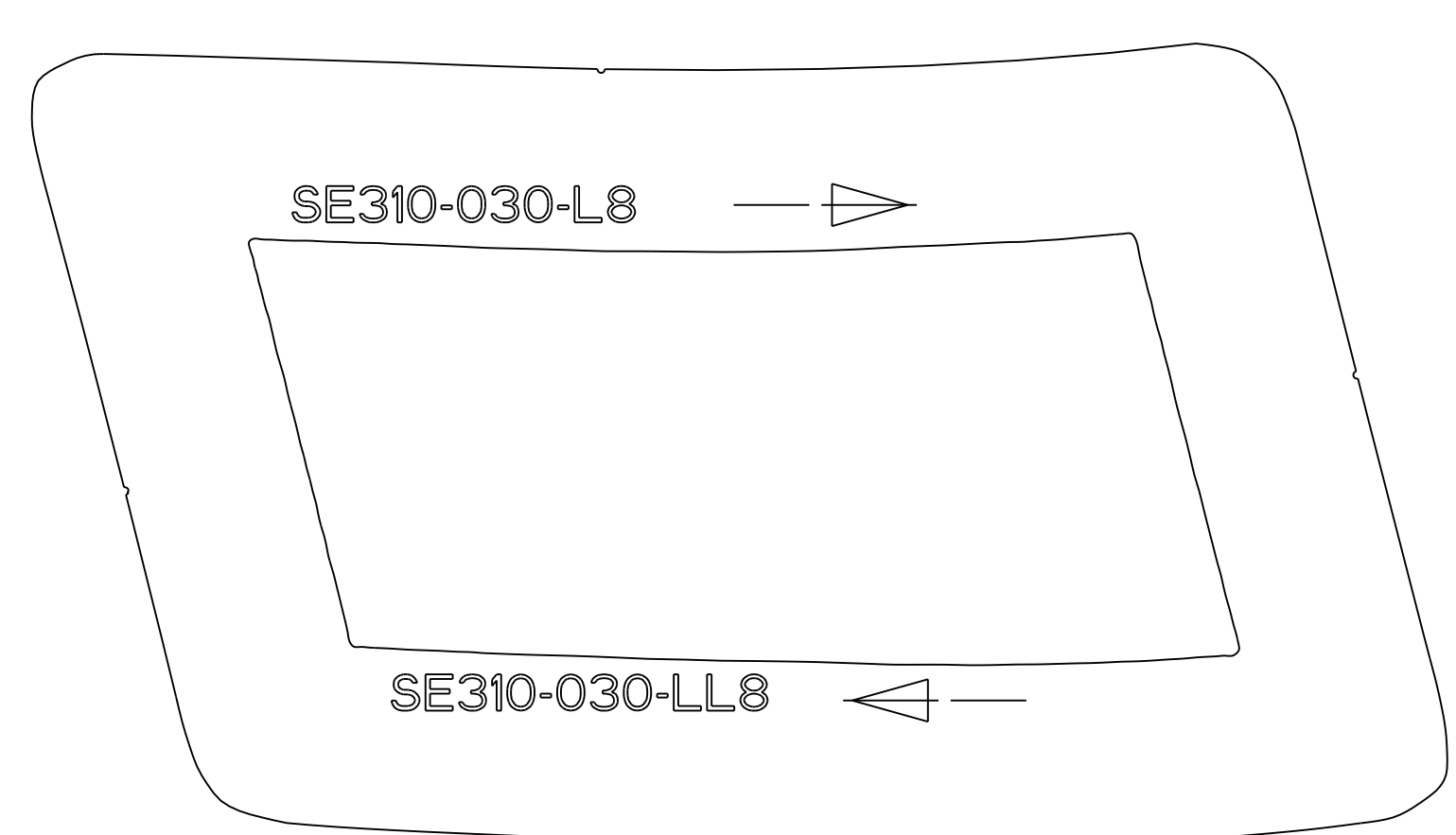

SE310-030-L8  
QNTY 2

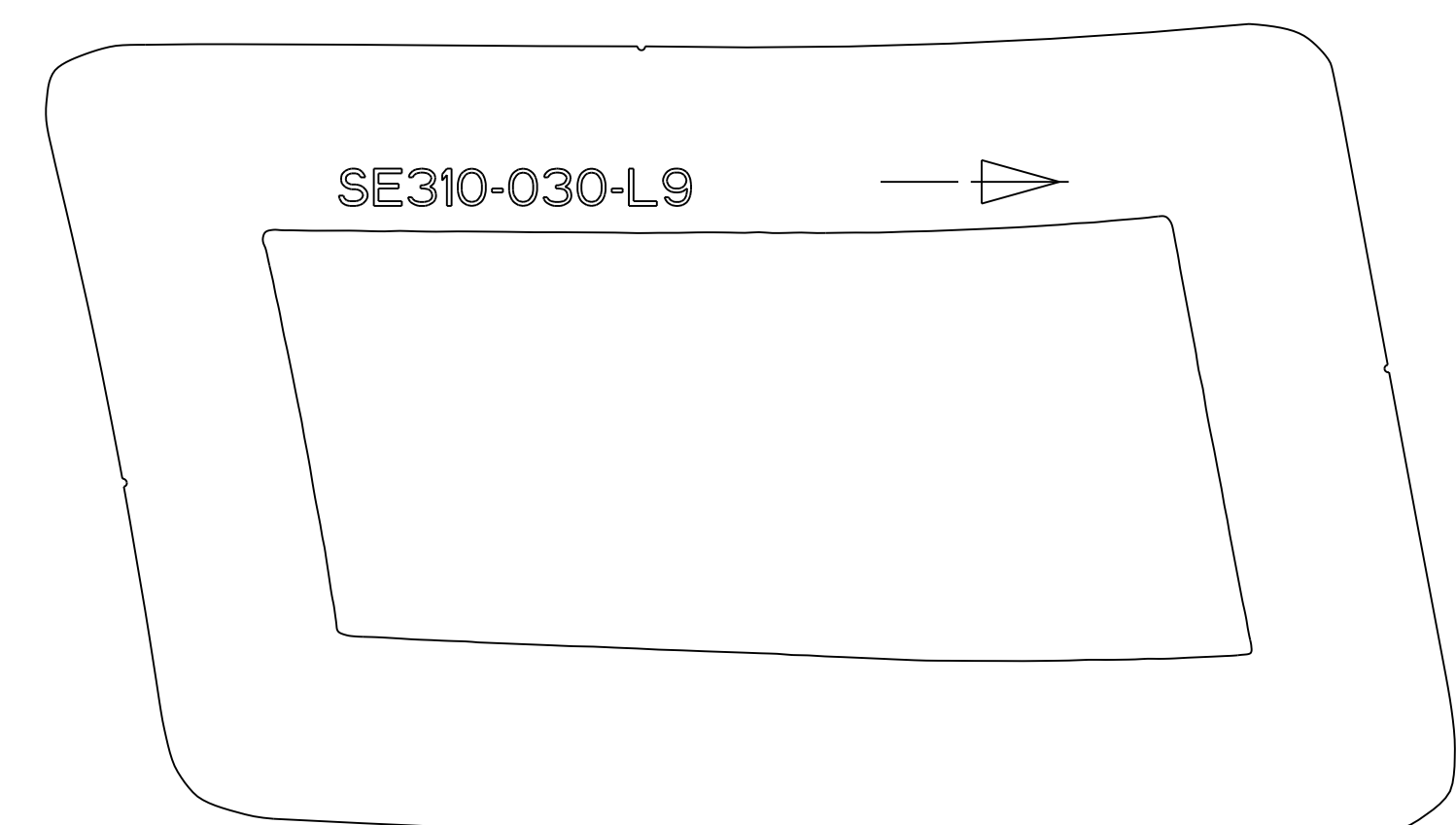

SE310-030-L9  
QNTY 1

RELEASE LEVEL:  
DWG VERSION NO:

WEIGHT	0.0 lbs
MODEL NAME	SE310-030-HH7
WELDING ENGINEER	

PART NO.	DRAWING NO.	NOMENCLATURE OR DESCRIPTION	MATERIAL	QTY RECD	SEE NOTES
PARTS LIST					
COMPUTER GENERATED DRAWING DRAWING CHANGES NOT PERMITTED Pro E		CENTRAL FILES: UNLESS OTHERWISE SPECIFIED	PRINCETON PLASMA PHYSICS LABORATORY PRINCETON UNIVERSITY NATIONAL COMPACT STELLARATOR EXPERIMENT		
DO NOT VERIFY INFORMATION BY SCALING DRAWING		DIMENSIONS ARE IN INCHES MACHINE SURFACES BREAK SHARP EDGES .005/ .020	DIAGNOSTICS MAGNETIC DIAGNOSTICS MAGNETIC LOOPS SERIES "L"		
NEXT ASSEMBLY		TOLERANCES NON-CUMULATIVE DECIMAL-INCH FRACTIONS .XX +/- .000 0°-120° +/- 15.0 .XXX +/- .005 72°-120° +/- 15.0 ANGULAR +/- 0°-15° OVER 120° +/- 15.0	DSN: T. BROWN 1/12/06	CHK: J. RUSHINSKI 1/12/06	DRAWING NO: <b>SE310-030-A.Q</b>
			SUPV: J. SIEGEL 1/12/06	ENGR: G. LABIK 1/12/06	SHEET 1 OF 15 REV 0

NCSX-SE310-030-A.Q

NO.	REVISION	BY	CH	SUP	APPROVED	DATE

FOR NOTES SEE SHEET 1



SE310-030-MM1

SE310-030-MM1  
QNTY 1

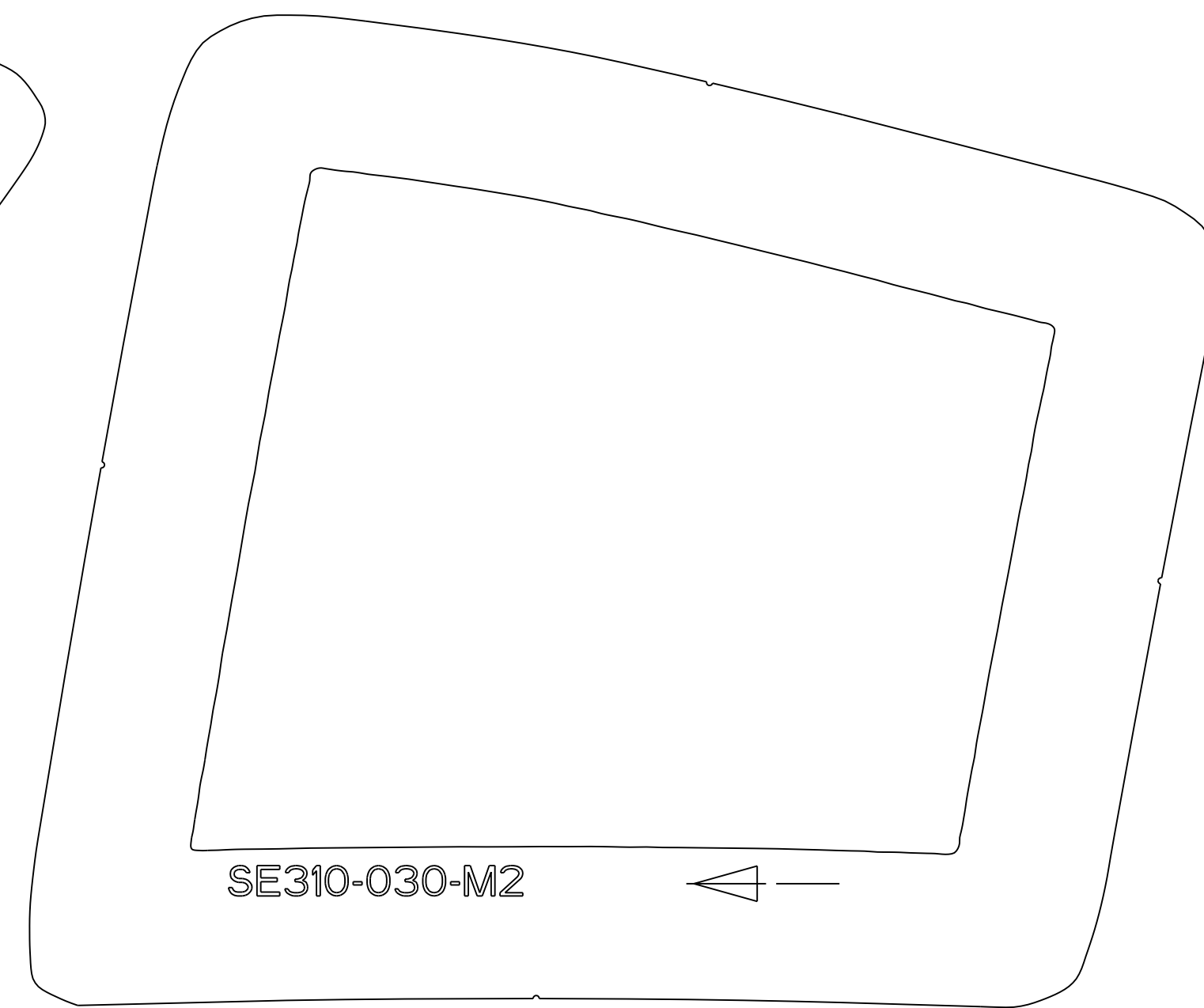

SE310-030-M2

SE310-030-M2  
QNTY 1

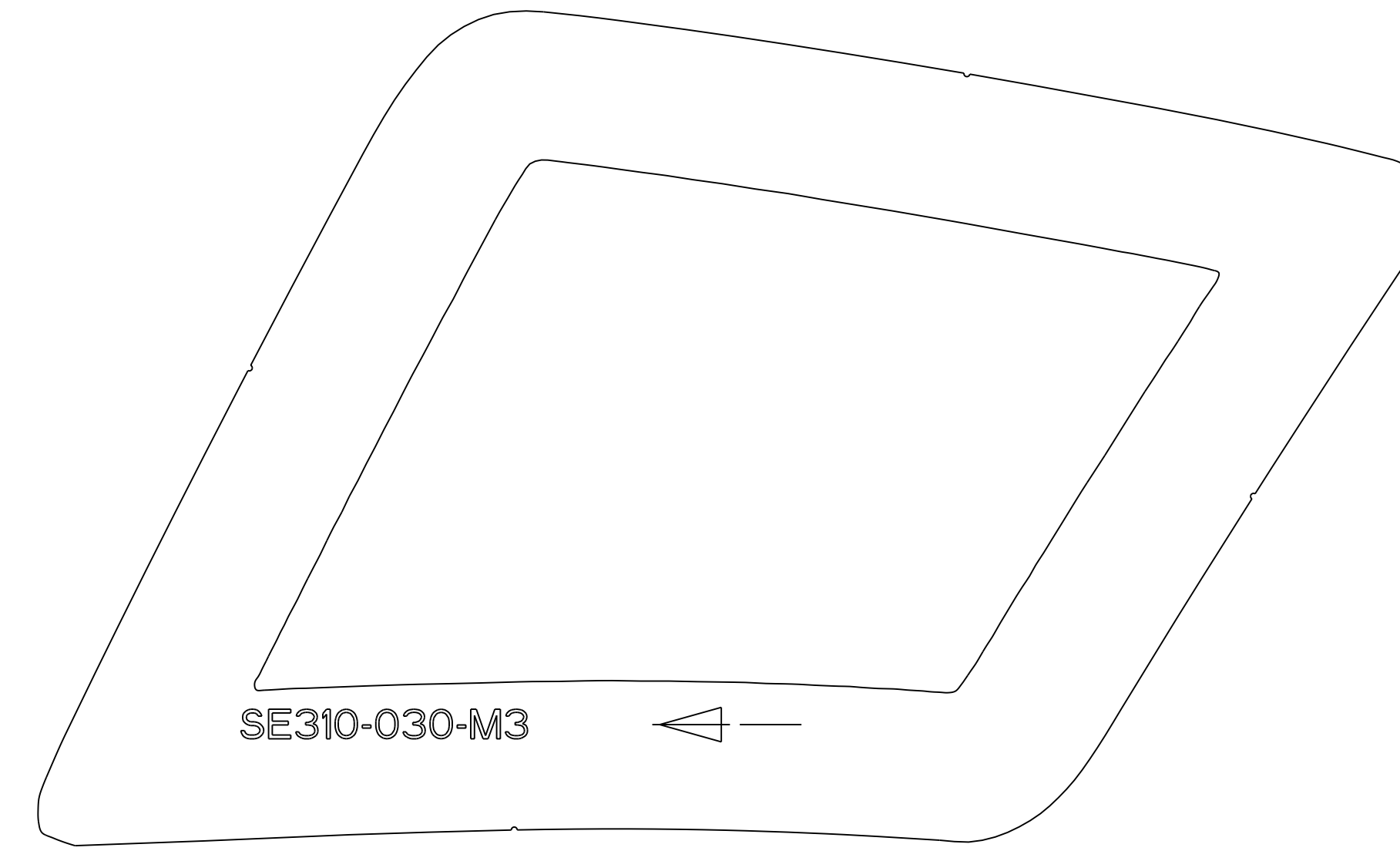

SE310-030-M3

SE310-030-M3  
QNTY 1

NOTCH LOCATION  
AND QUANTITY  
VARIES BY PART

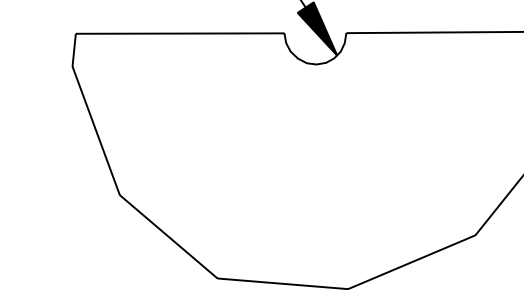

DETAIL A  
SCALE 8.000

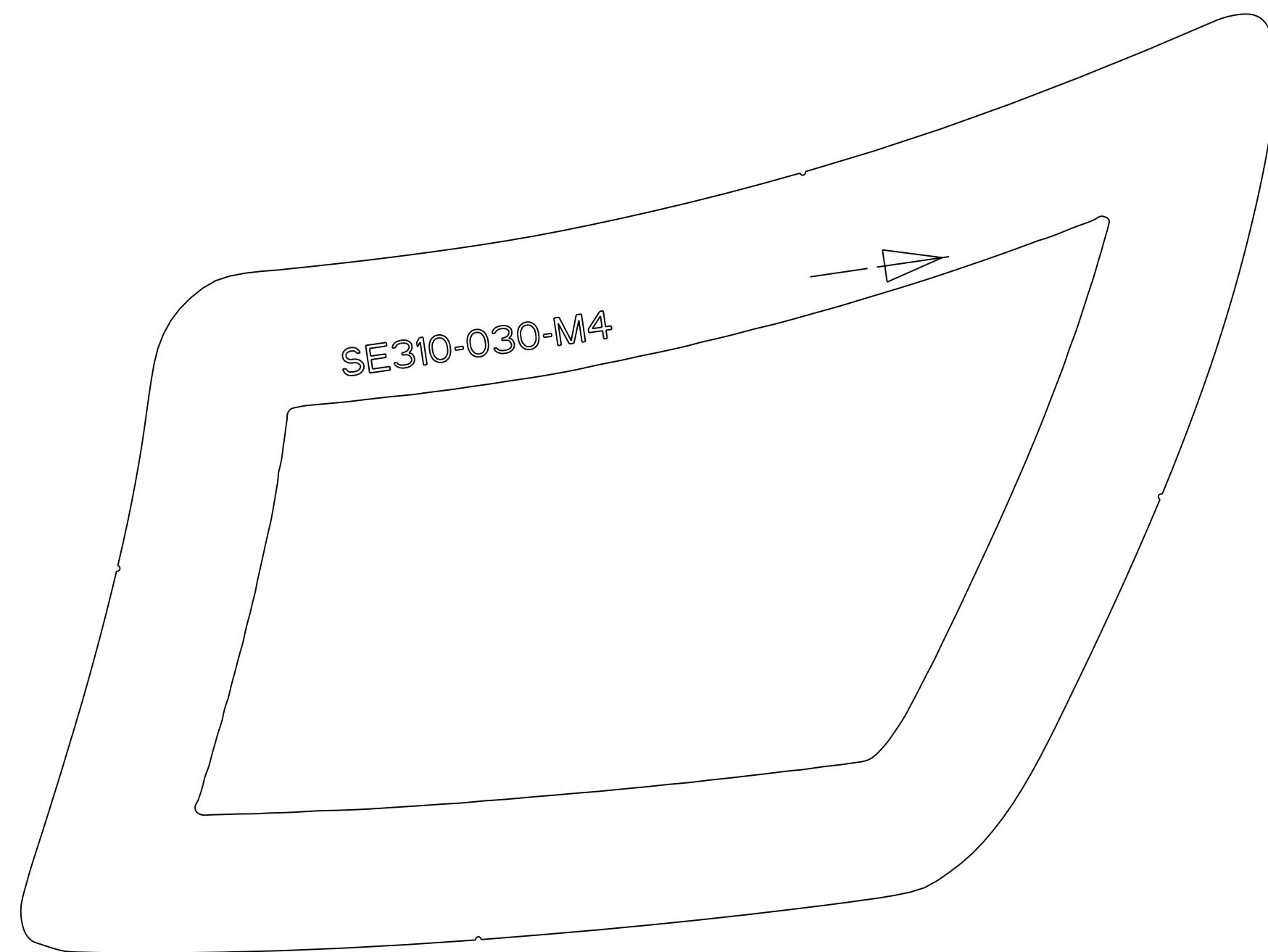

SE310-030-M4

SE310-030-M4  
QNTY 1

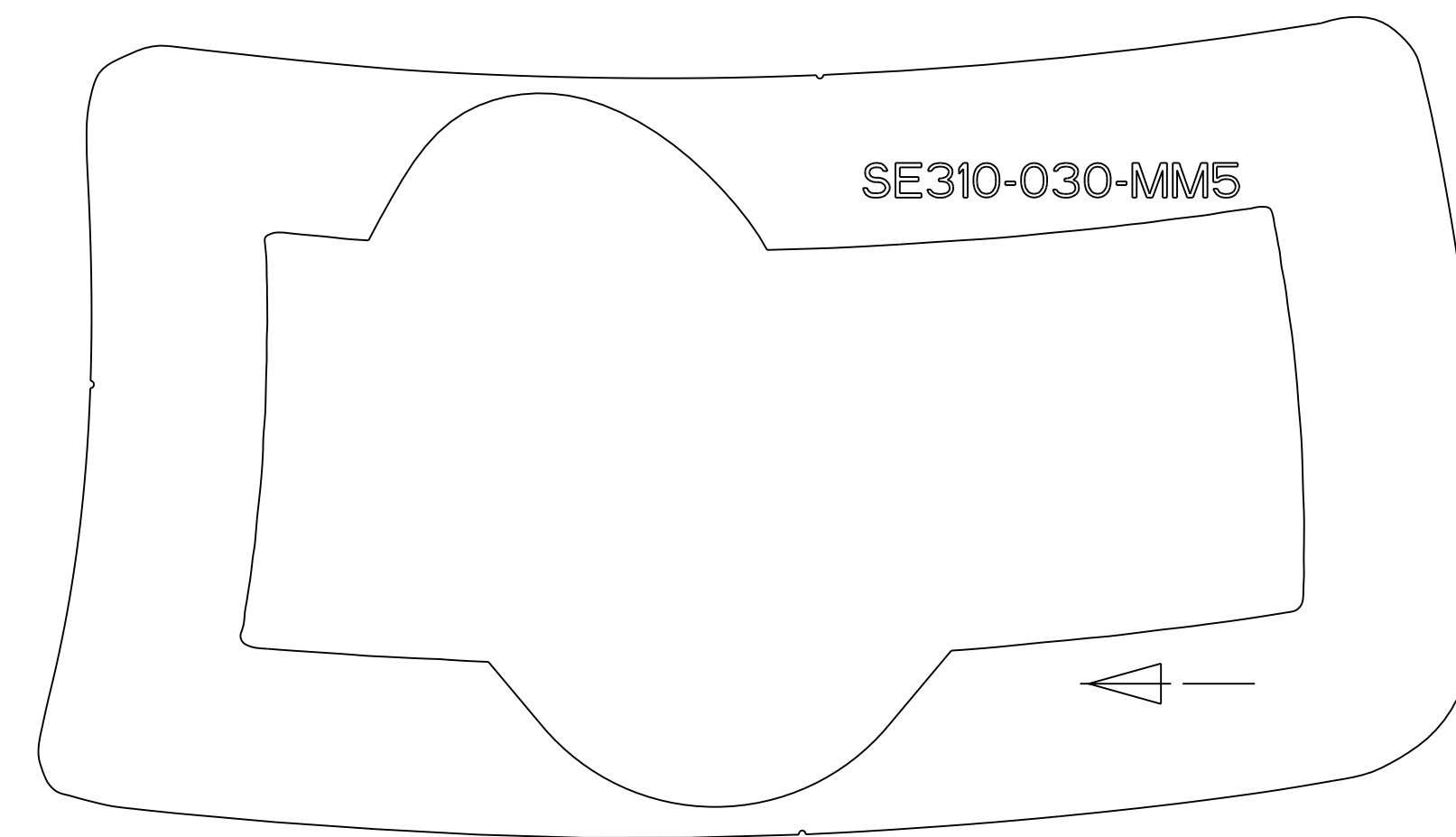

SE310-030-MM5

SE310-030-MM5  
QNTY 1

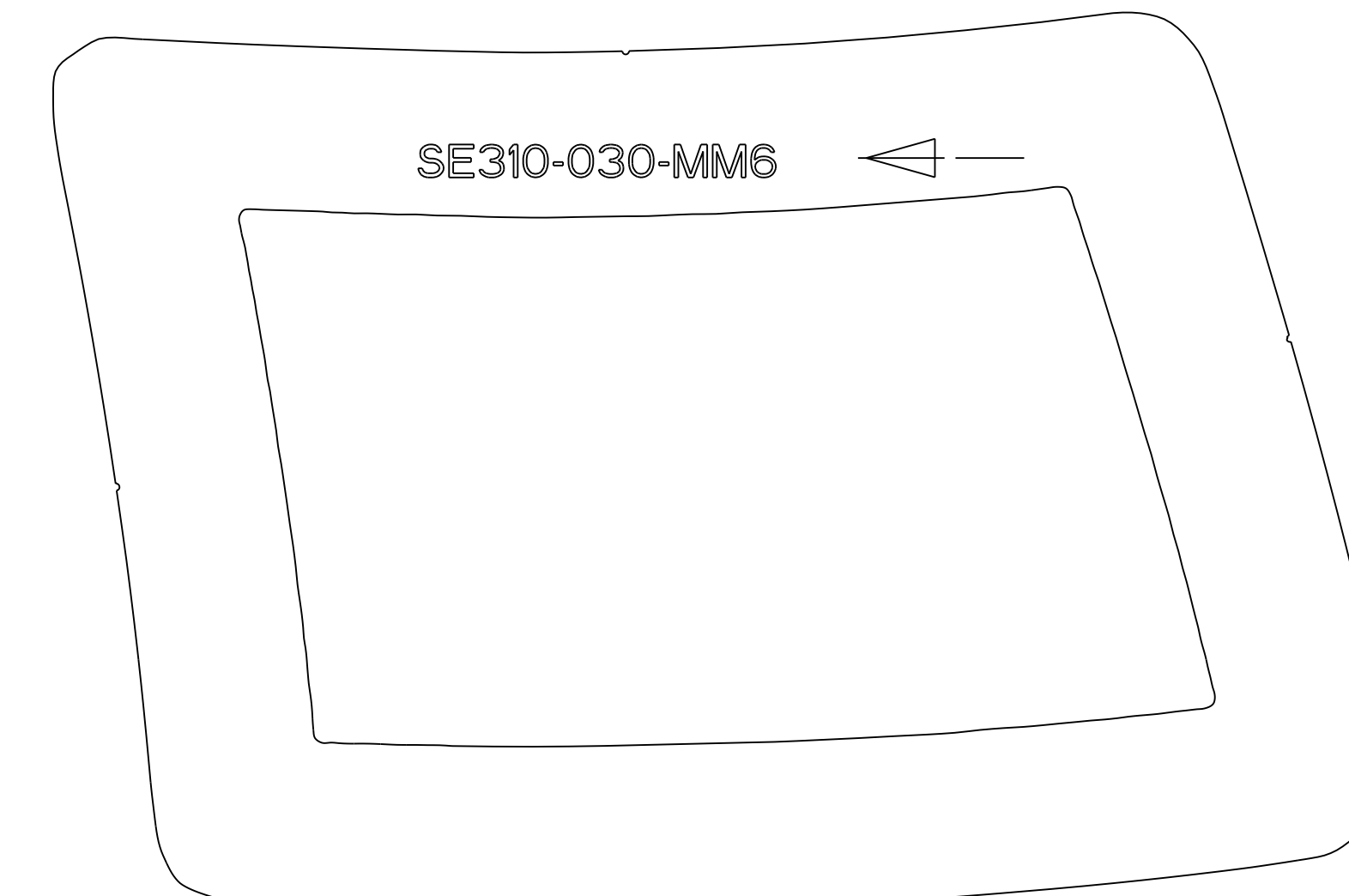

SE310-030-MM6

SE310-030-MM6  
QNTY 1

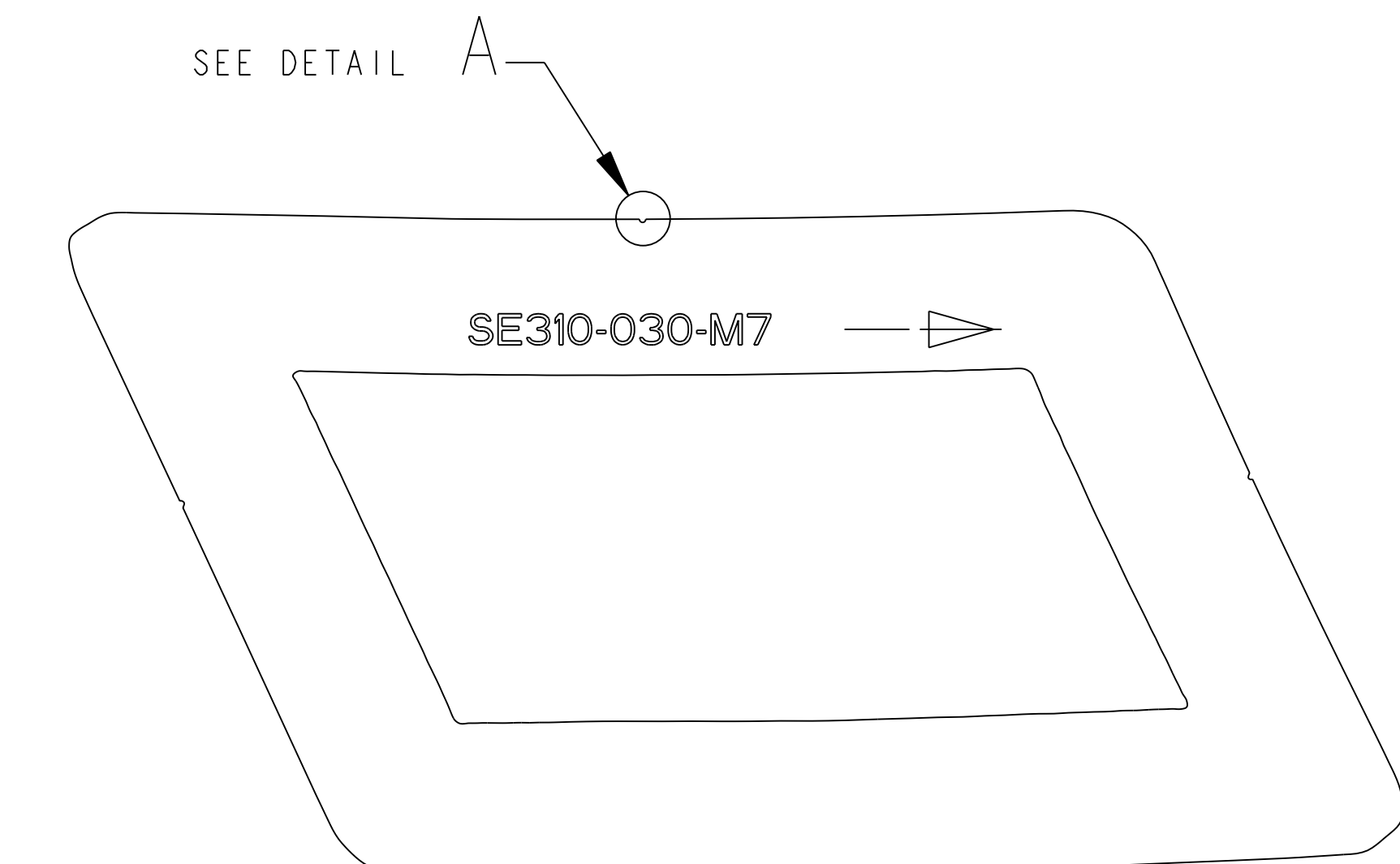

SE310-030-M7

SE310-030-M7  
QNTY 1

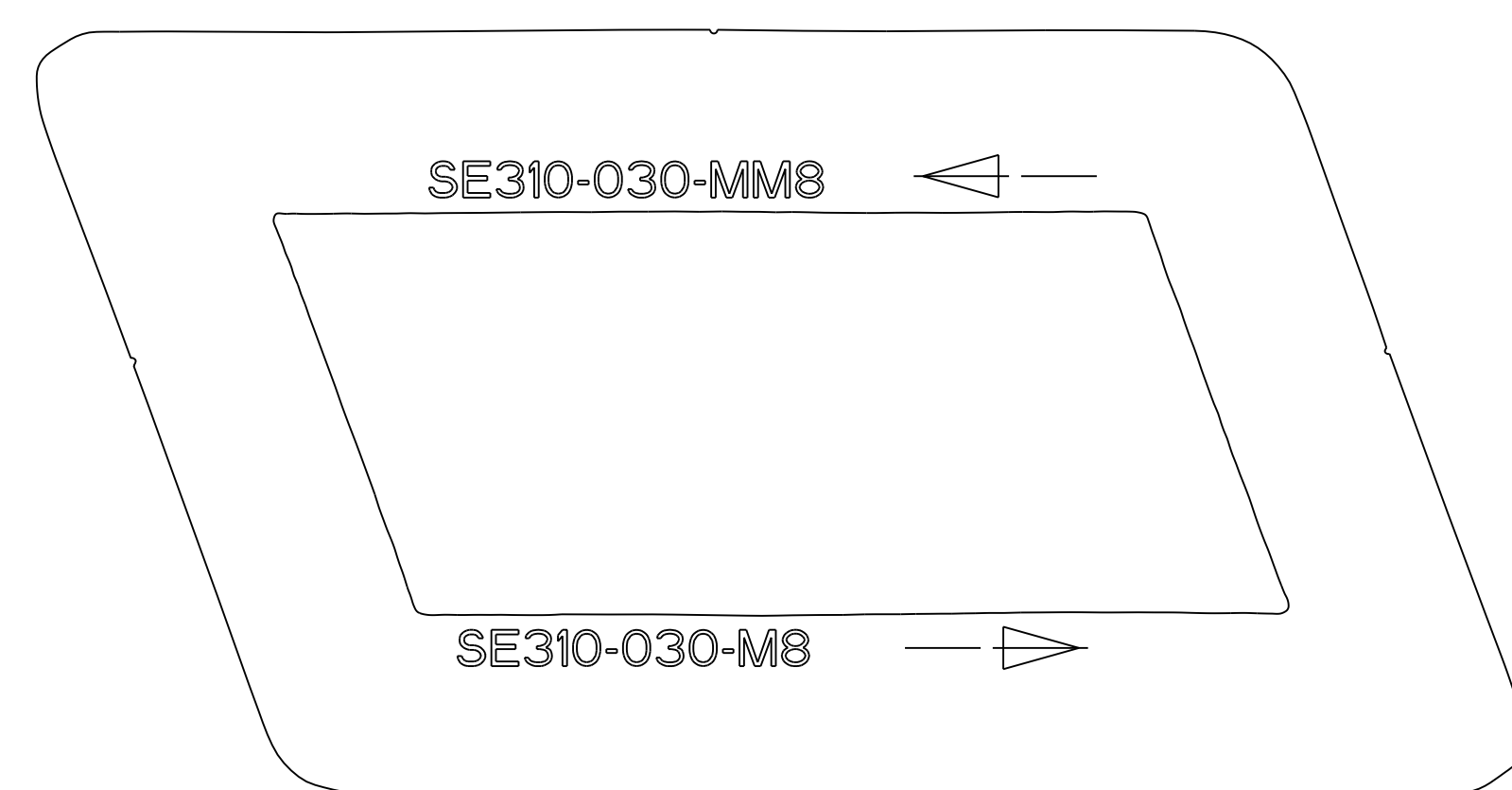

SE310-030-MM8

SE310-030-MM8  
QNTY 2

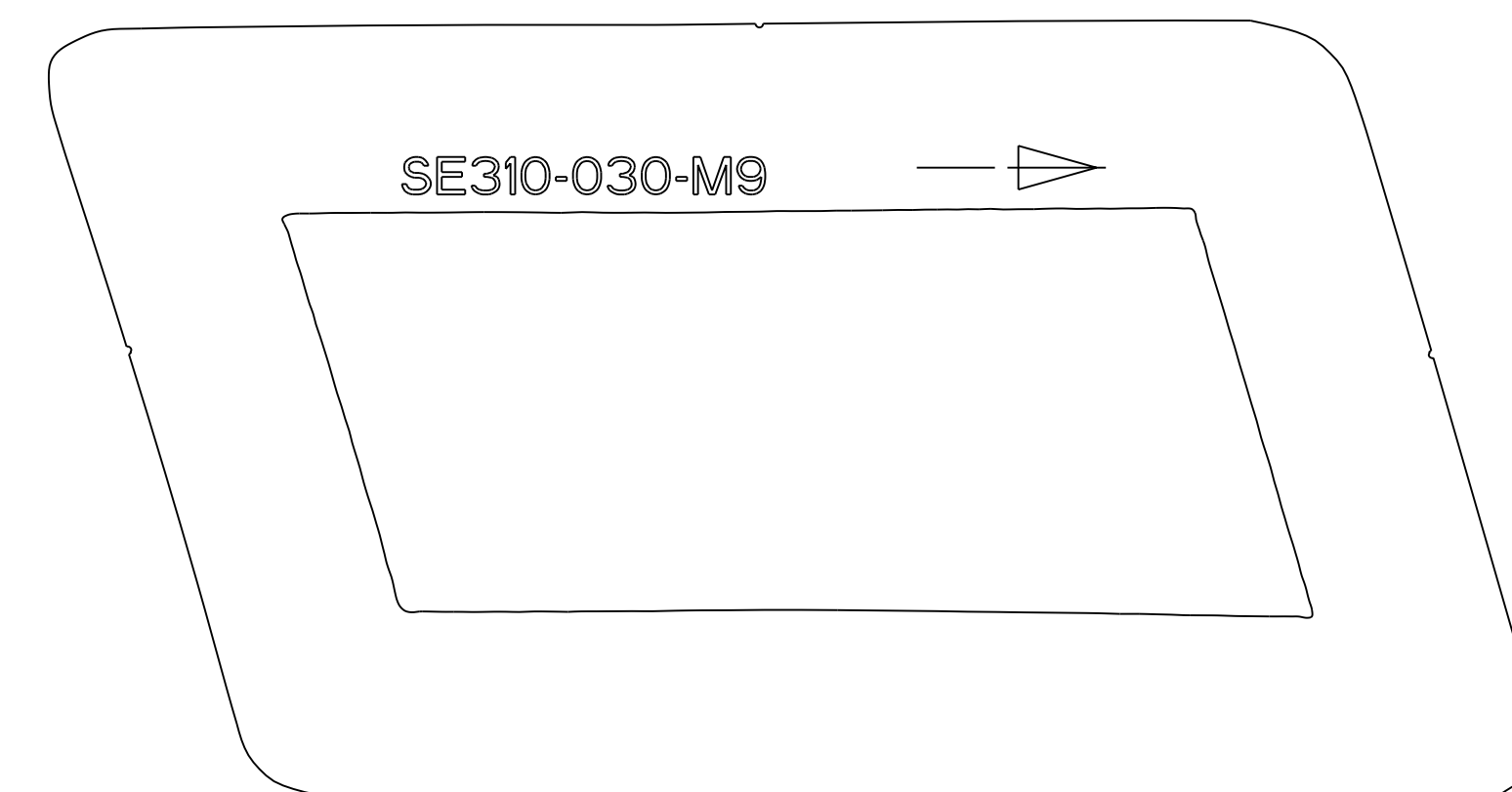

SE310-030-M9

SE310-030-M9  
QNTY 1

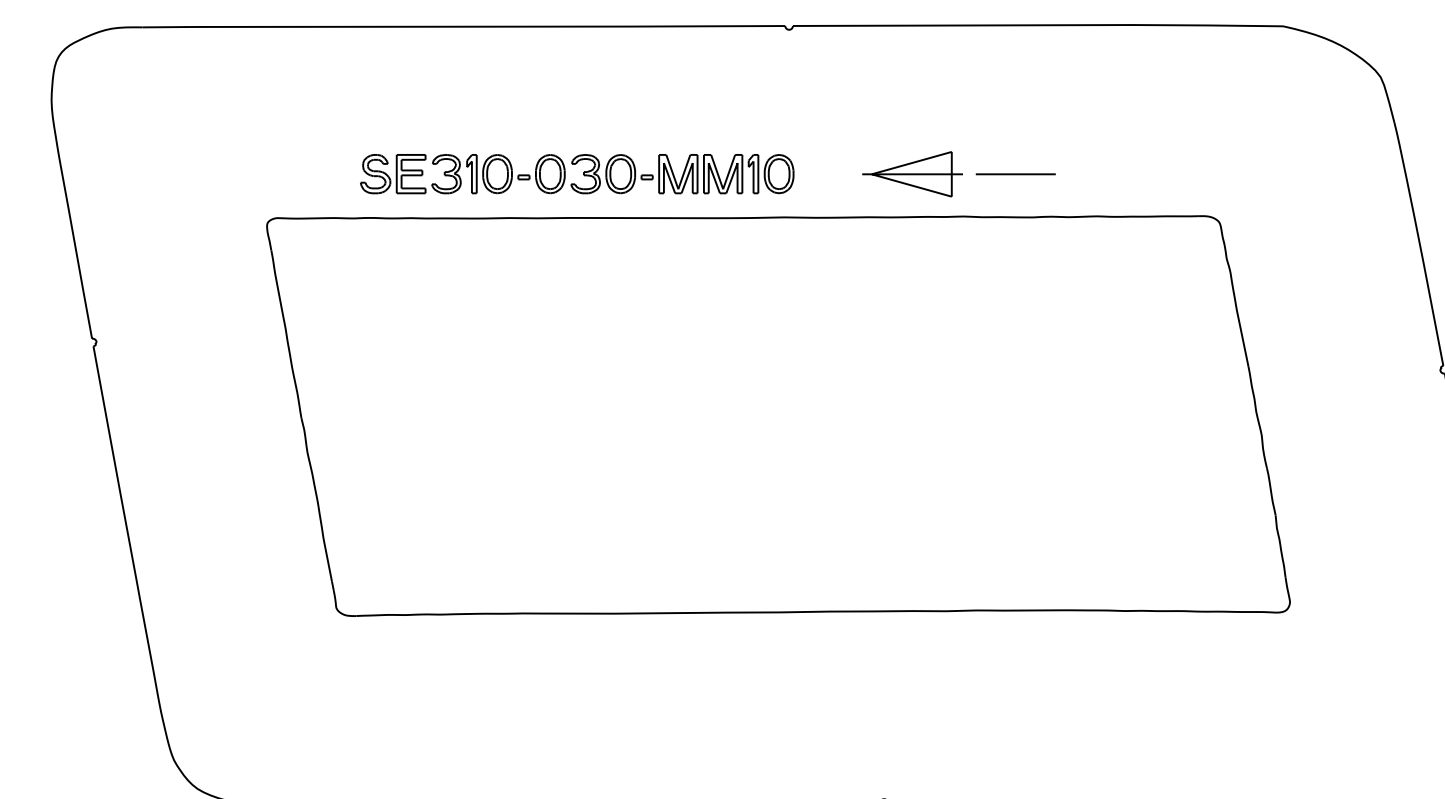

SE310-030-MM10

SE310-030-MM10  
QNTY 1

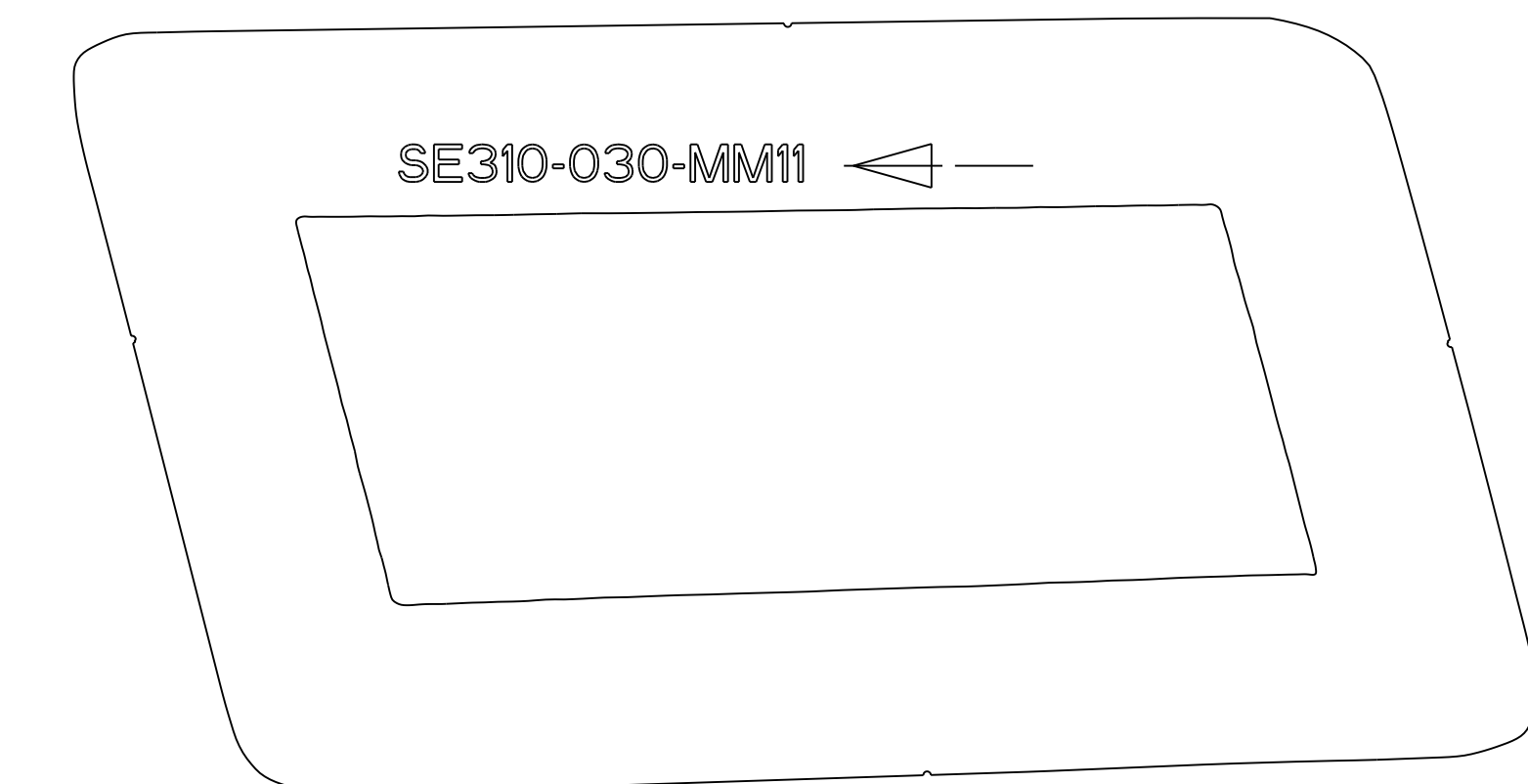

SE310-030-MM11

SE310-030-MM11  
QNTY 1

RELEASE LEVEL:  
DWG VERSION NO:

WEIGHT  
0.0 lbs  
MODEL NAME  
SE310-030-HH7  
WELDING  
ENGINEER

PART NO.	DRAWING NO.	NOMENCLATURE OR DESCRIPTION	SEE NOTES	QTY REOD
PARTS LIST				
COMPUTER GENERATED DRAWING MANUAL CHANGES NOT PERMITTED Pro E		CENTRAL FILES: UNLESS OTHERWISE SPECIFIED DIMENSIONS ARE IN INCHES MACHINE SURFACES BREAK SHARP EDGES .005/.020	PRINCETON PLASMA PHYSICS LABORATORY PRINCETON UNIVERSITY DIAGNOSTICS MAGNETIC DIAGNOSTICS MAGNETIC LOOPS SERIES "M"	
DO NOT VERIFY INFORMATION BY SCALING DRAWING	TOLERANCES NON-CUMULATIVE	DSN: T. BROWN	1/12/06	DRAWING NO:
NEXT ASSEMBLY	DECIMAL-INCH FRACTIONS	CHK: J. RUSHINSKI	1/12/06	SE310-030-A.Q
	.XX +/- .000 0°-12° +/- 1/16	ENGR: G. LABIK	1/12/06	
	.XXX +/- .005 12°-120° +/- 1/16	SUPV: J. SIEGEL	1/12/06	SHEET 12 OF 15 REV 0
	ANGULAR +/- 0°-15° OVER 120° +/- 1/16			

NCSX-SE310-030-A.Q

NO.	REVISION	BY	CH	SUP	APPROVED	DATE

FOR NOTES SEE SHEET 1

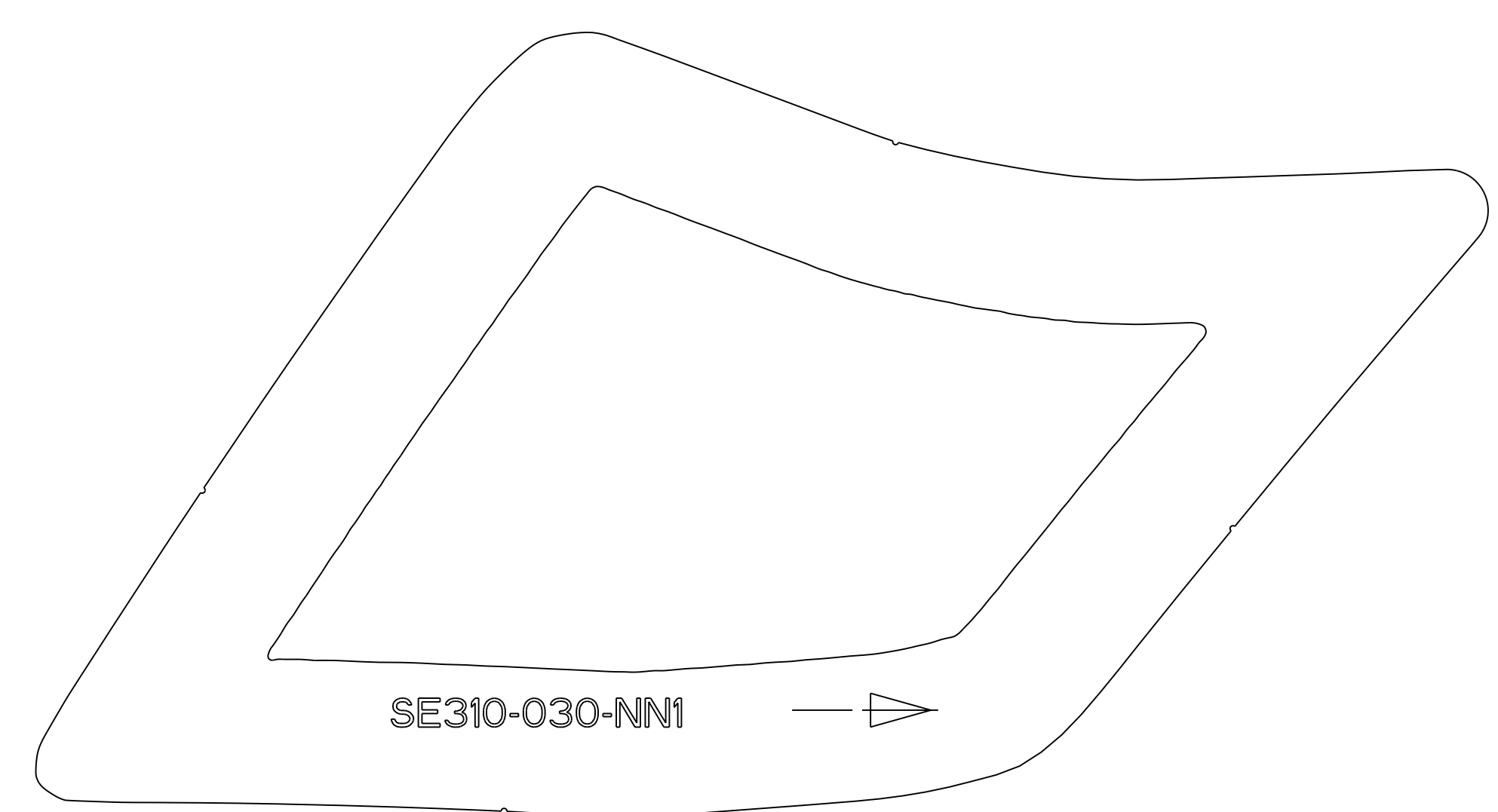

SE310-030-NN1

SE310-030-NN1  
QNTY 1

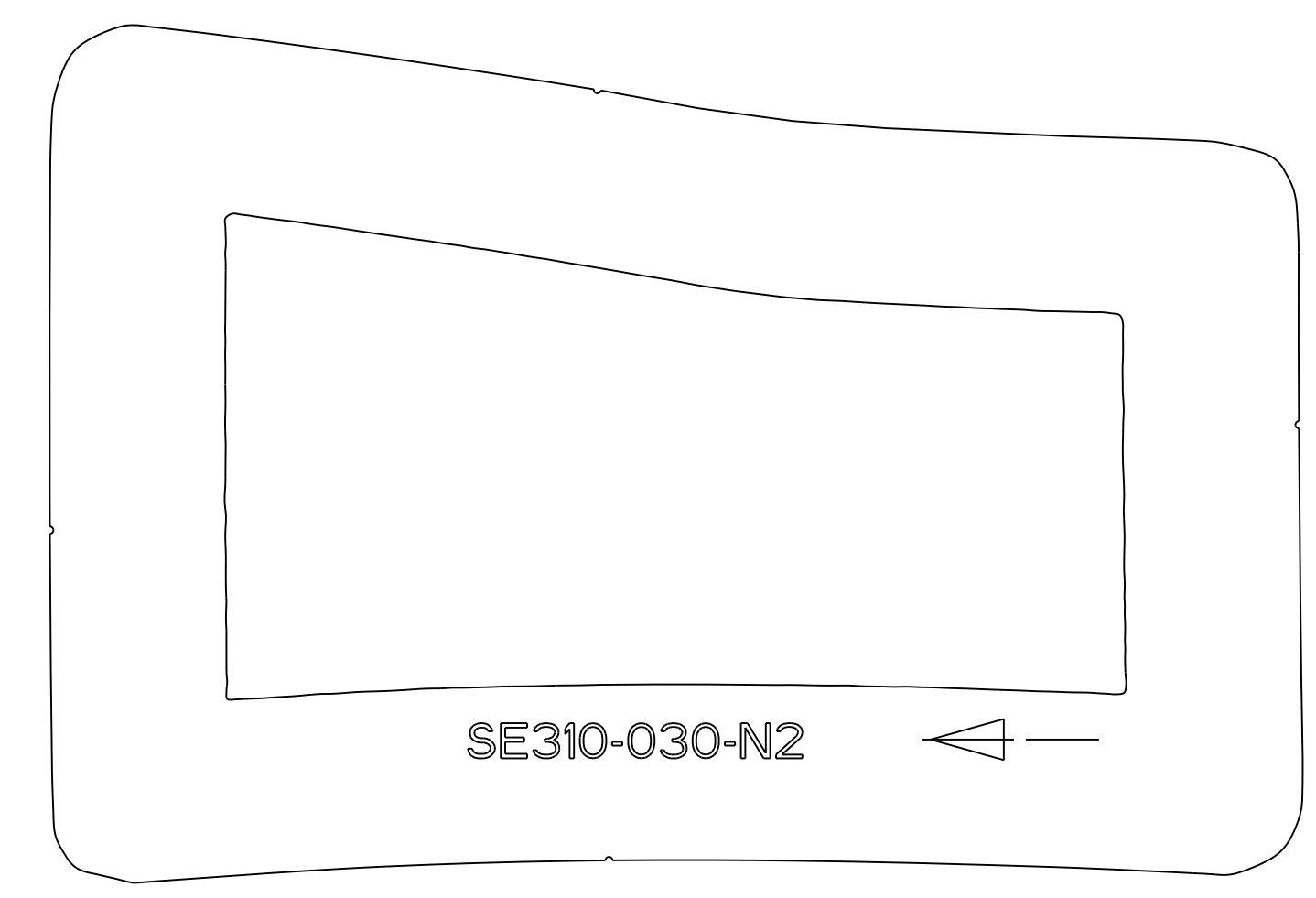

SE310-030-N2

SE310-030-N2  
QNTY 1

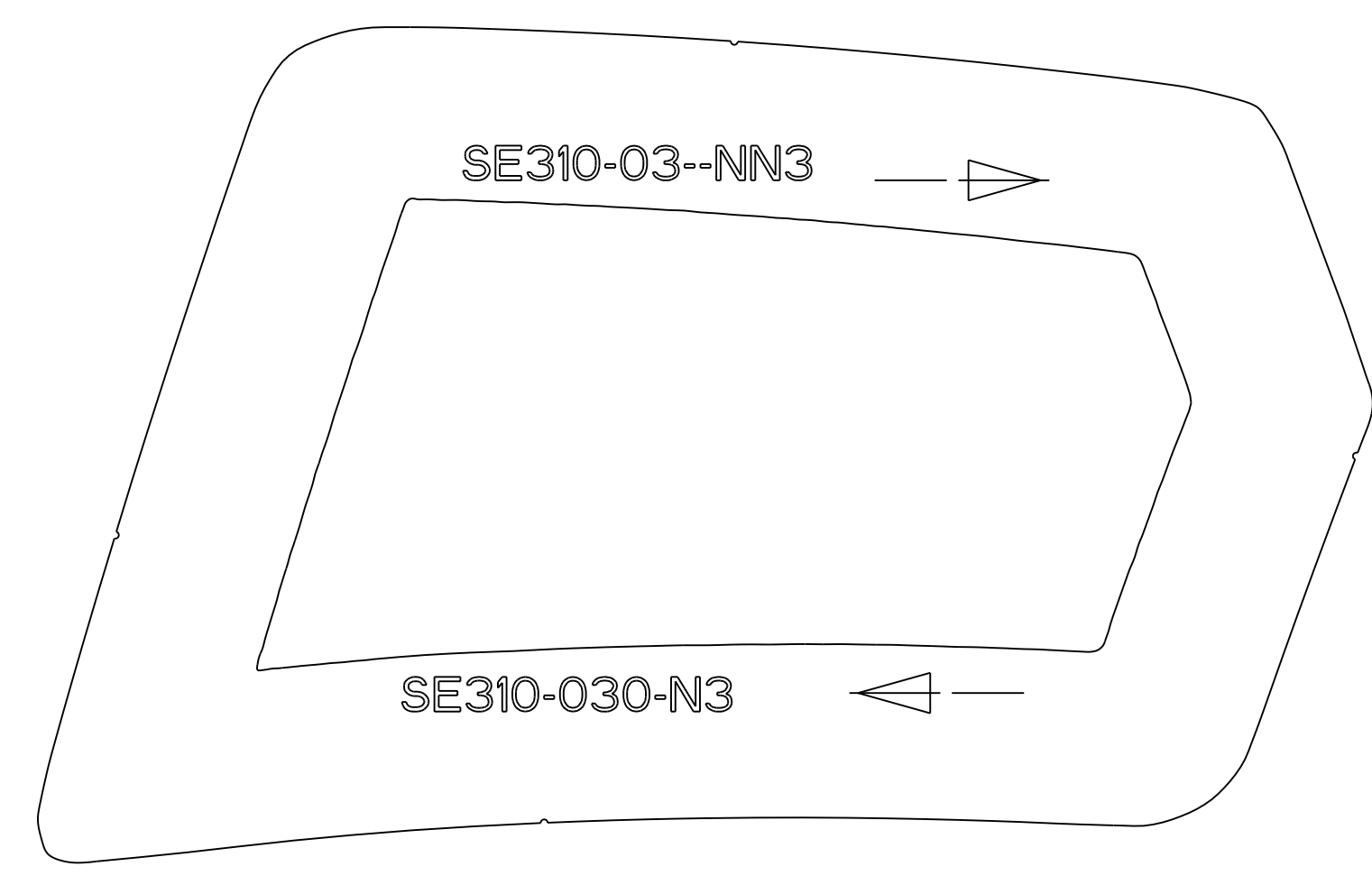

SE310-030-NN3

SE310-030-N3

SE310-030-N3  
QNTY 1

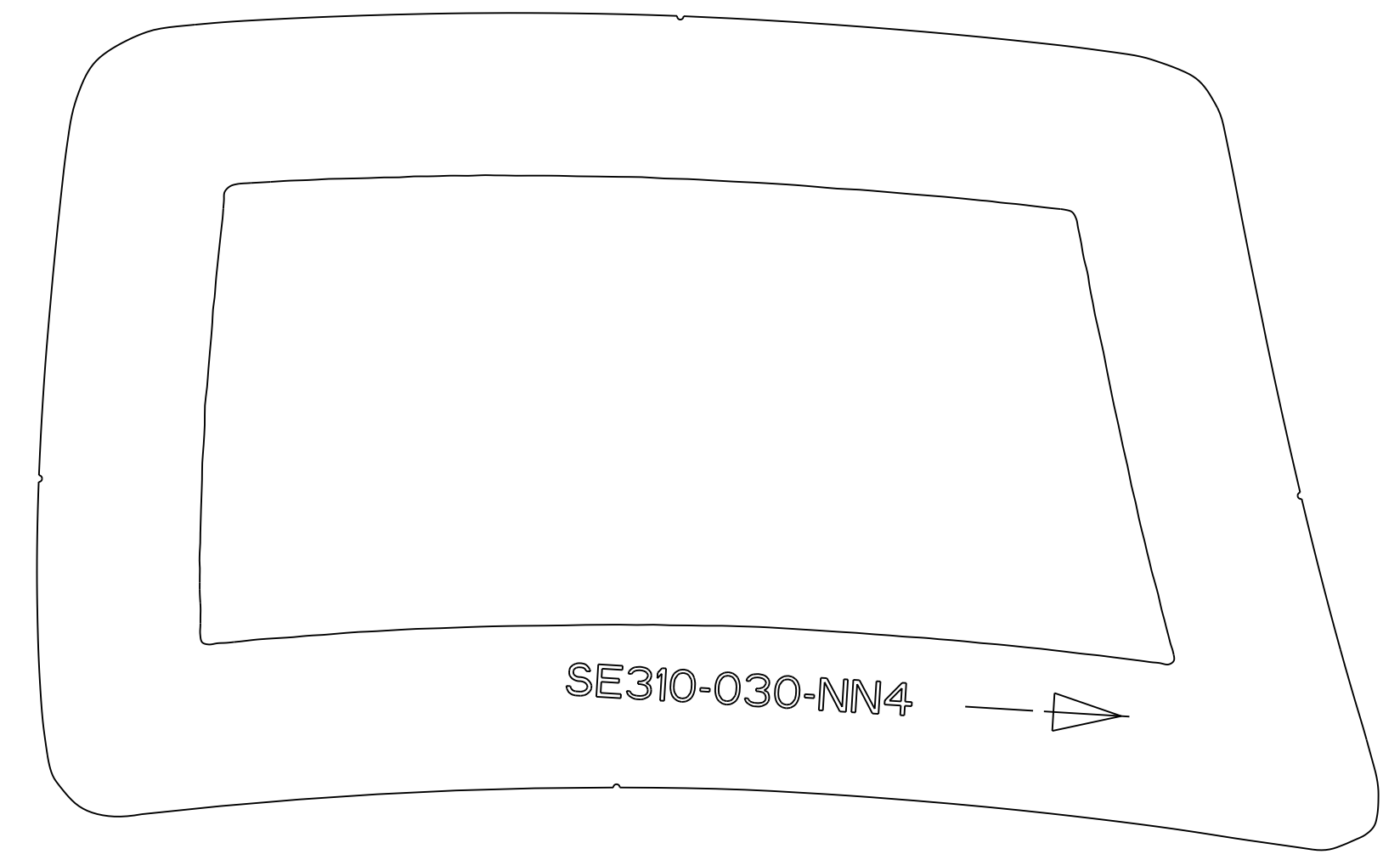

SE310-030-NN4

SE310-030-NN4  
QNTY 1

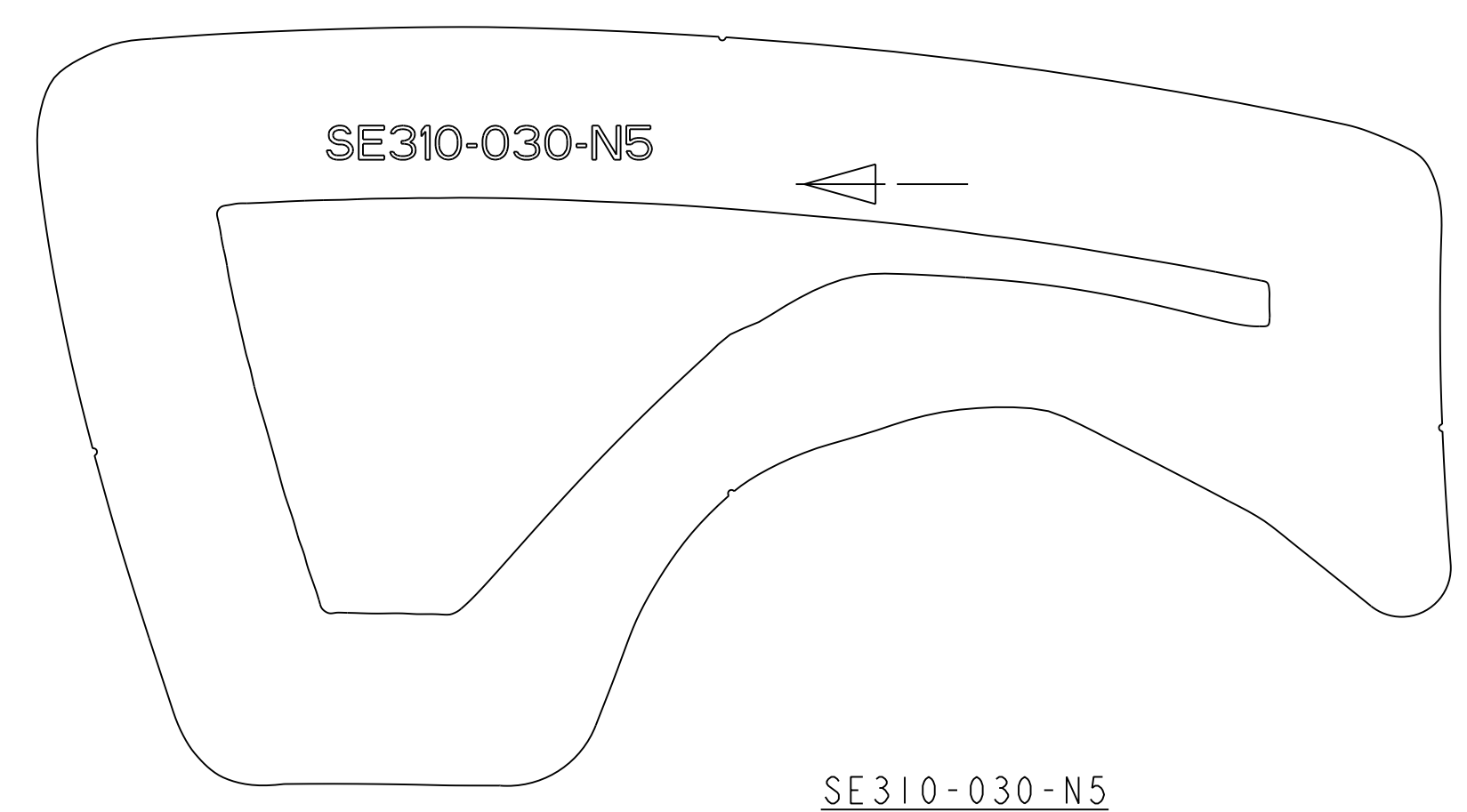

SE310-030-N5

SE310-030-N5  
QNTY 1

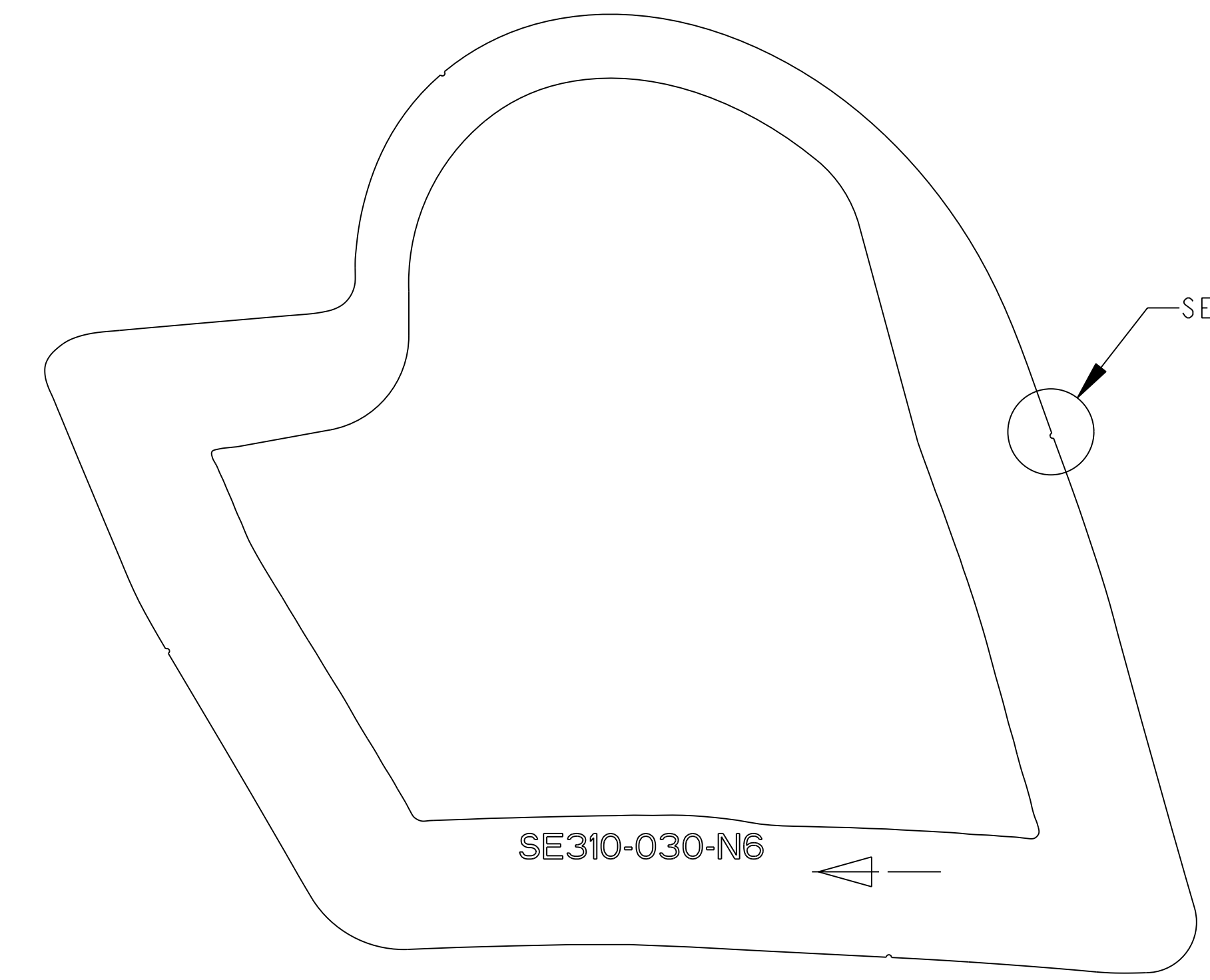

SE310-030-N6

SE310-030-N6  
QNTY 1

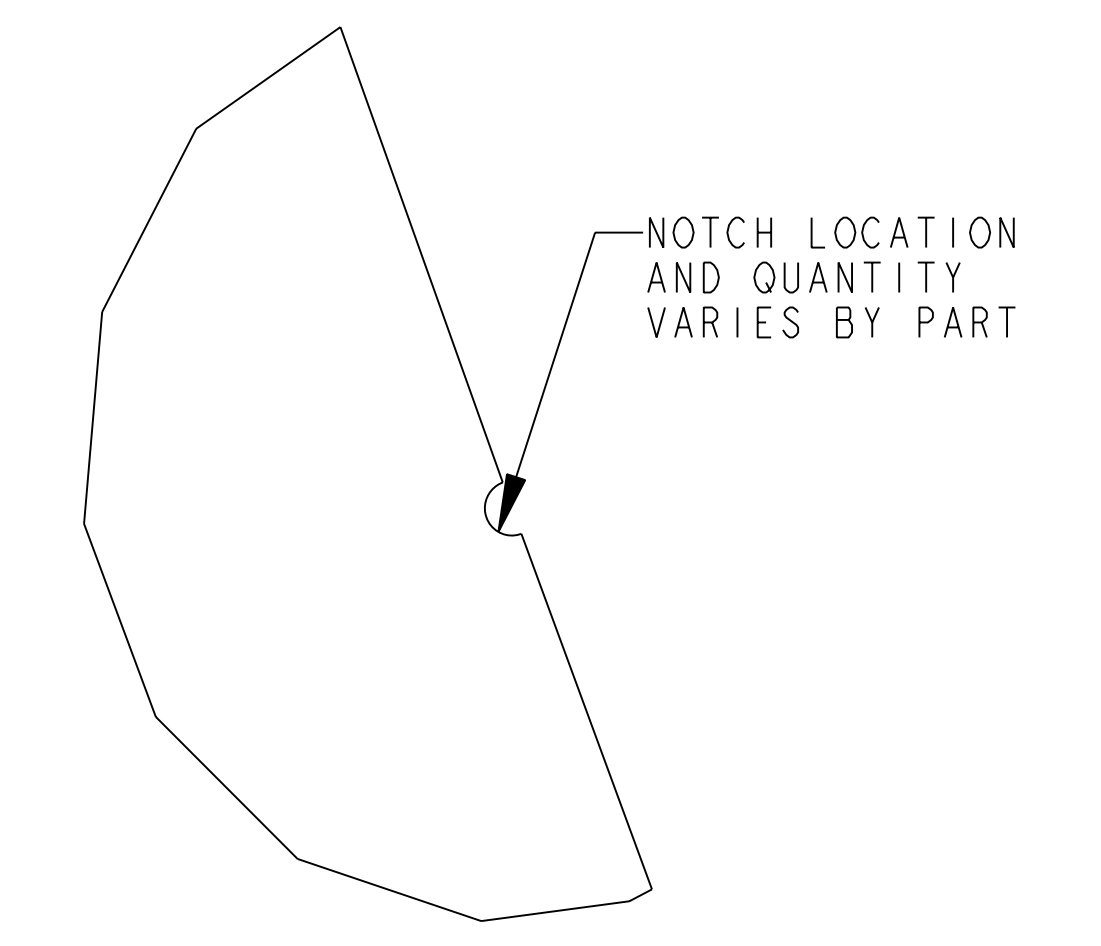

DETAIL A  
SCALE 7.000

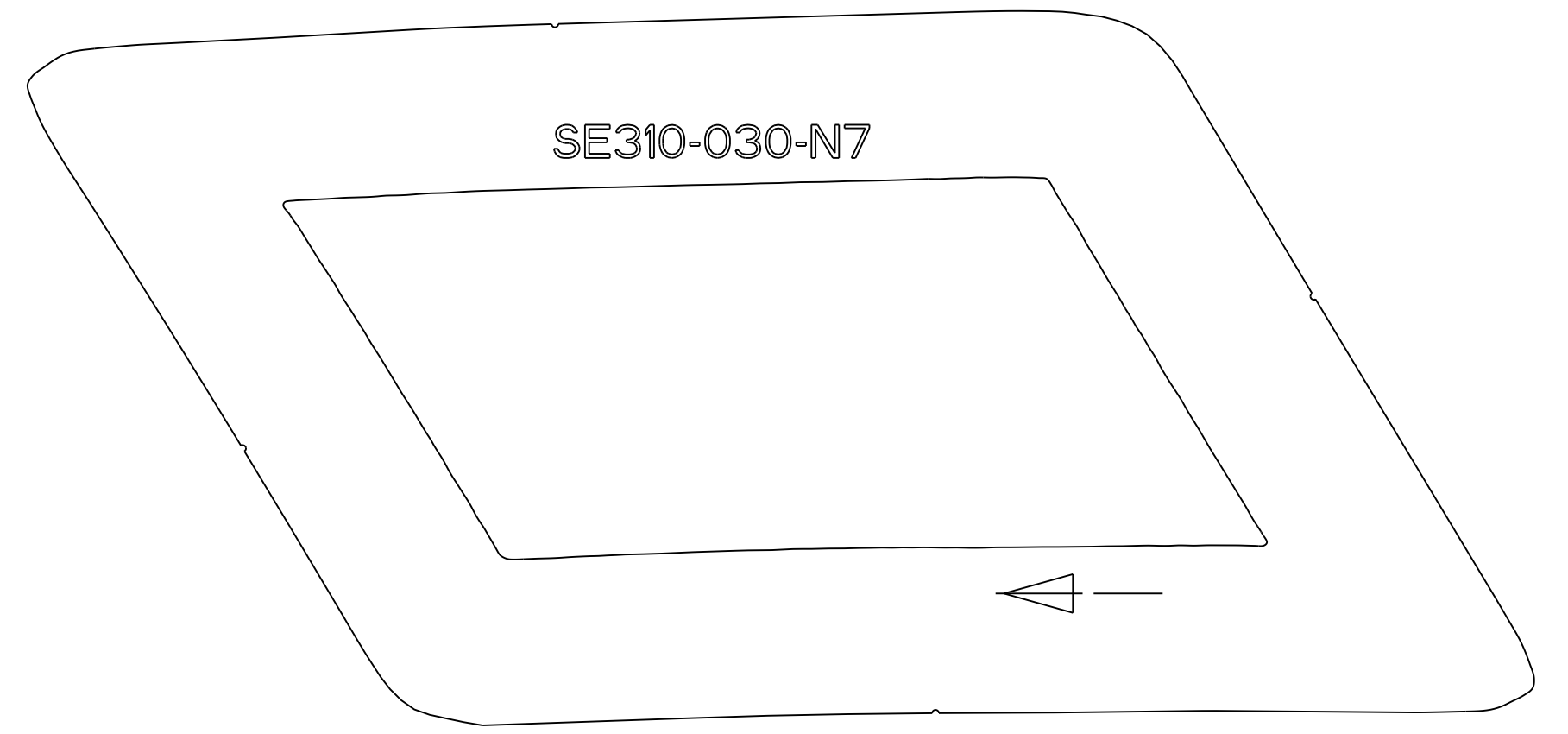

SE310-030-N7

SE310-030-N7  
QNTY 1

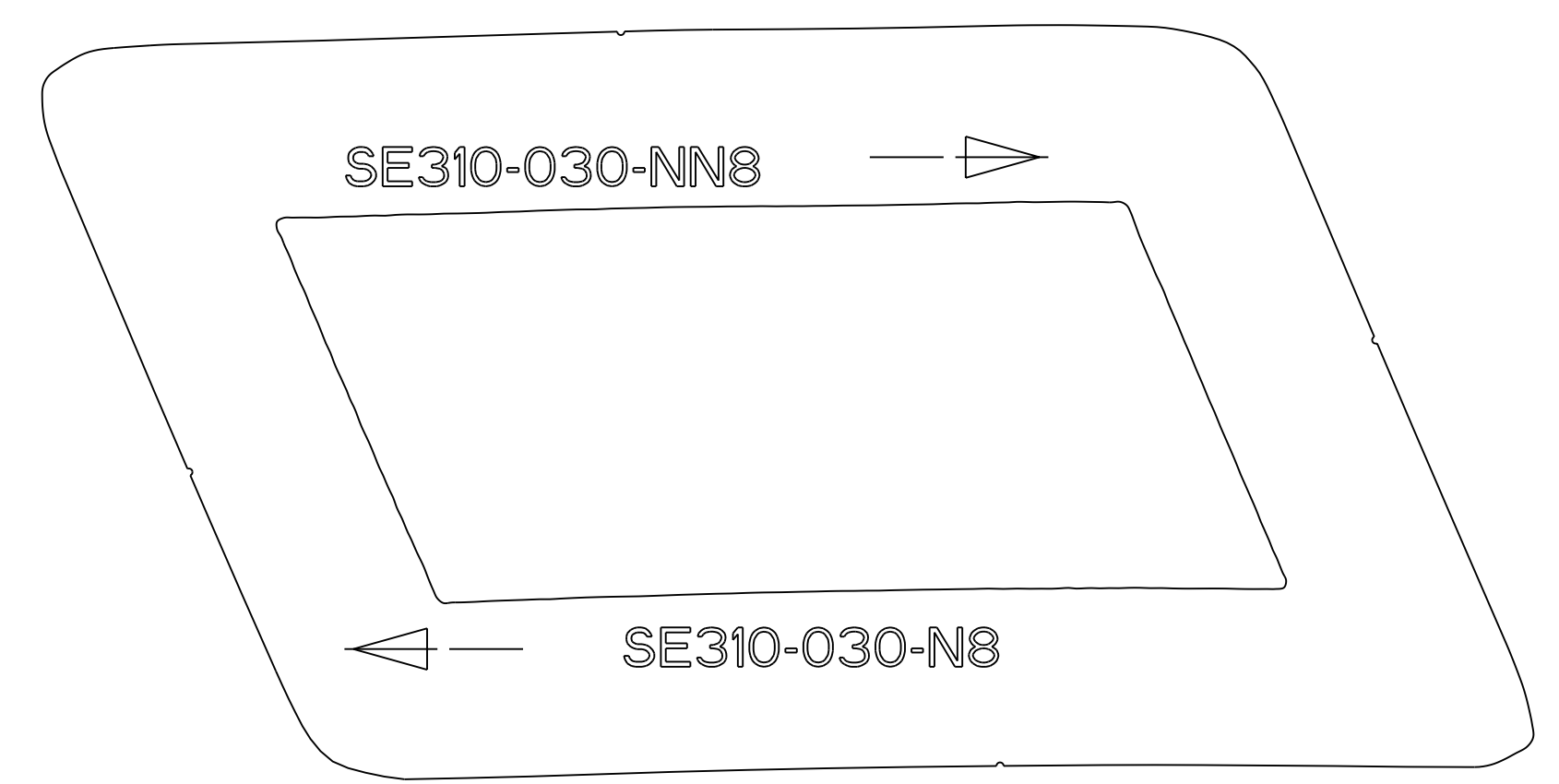

SE310-030-NN8

SE310-030-N8

SE310-030-N8  
QNTY 2

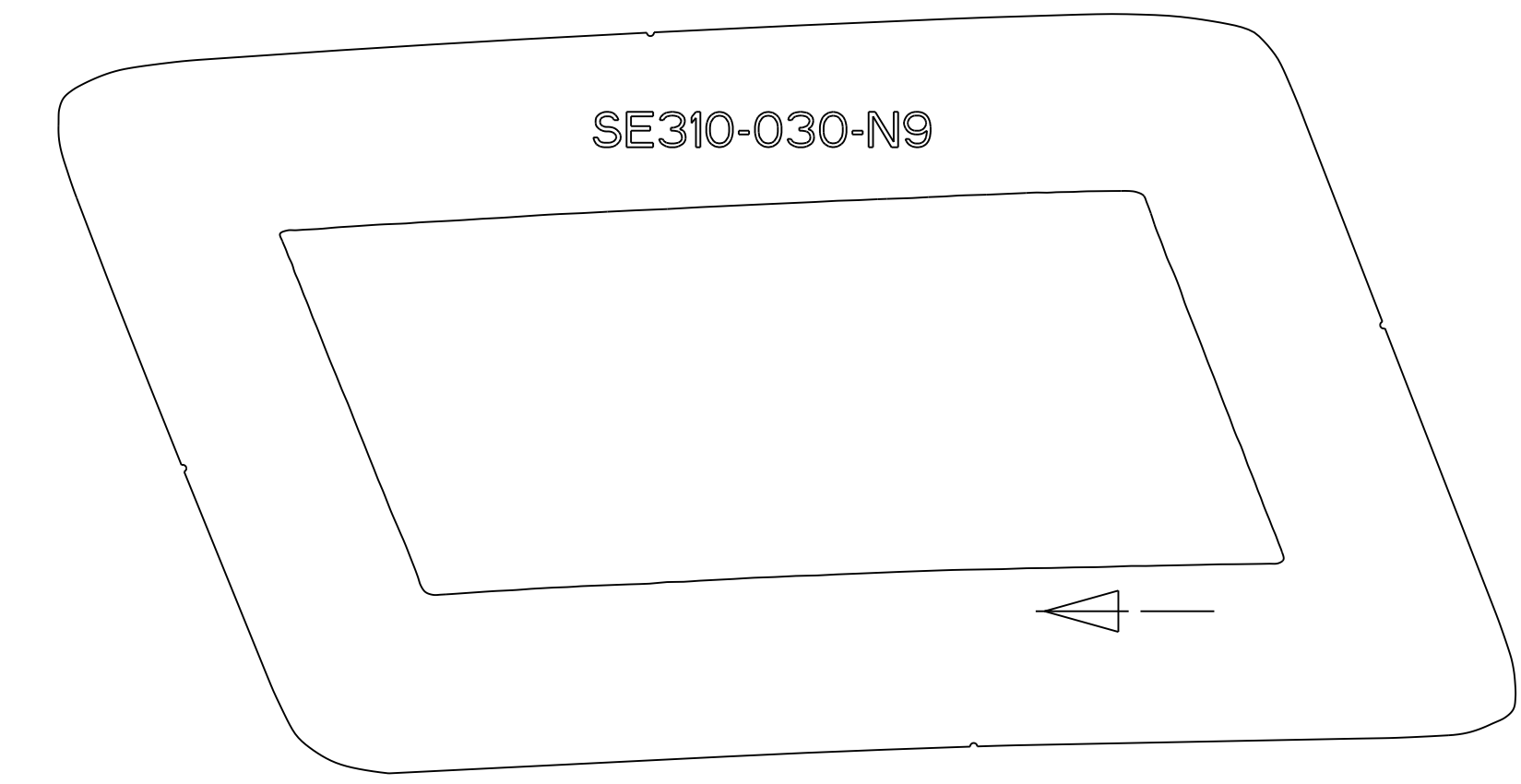

SE310-030-N9

SE310-030-N9  
QNTY 1

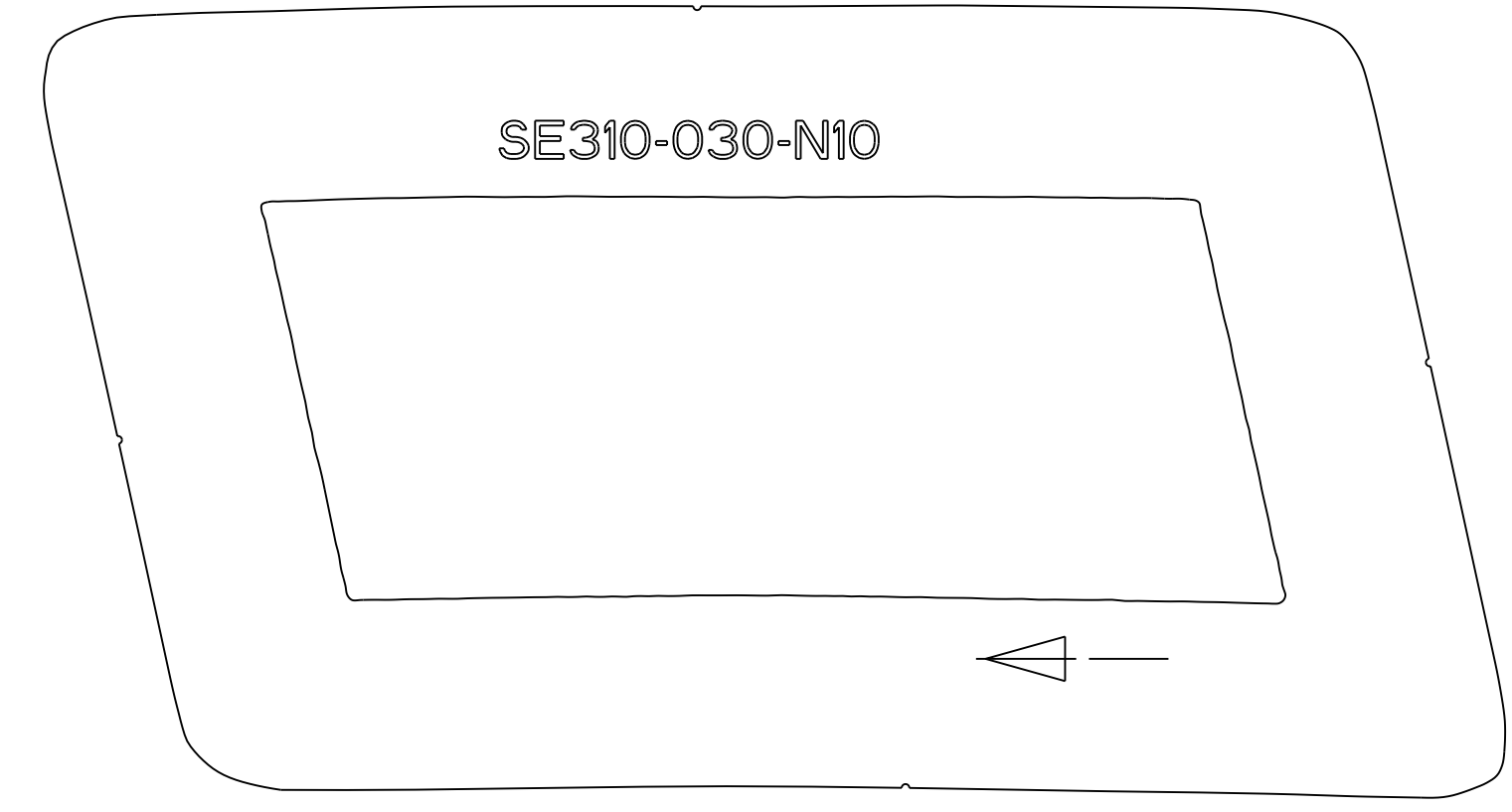

SE310-030-N10

SE310-030-N10  
QNTY 1

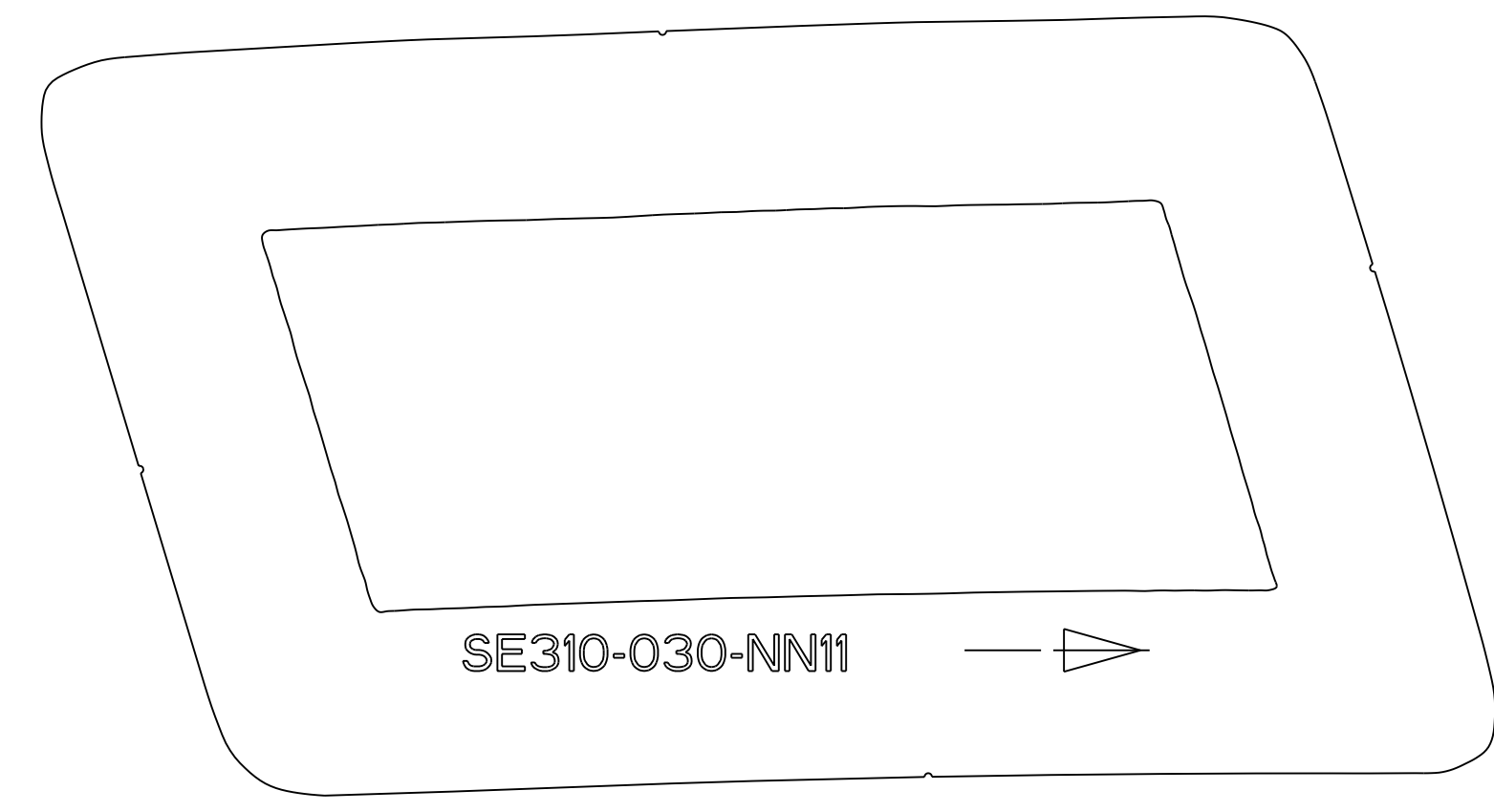

SE310-030-NN11

SE310-030-NN11  
QNTY 1

RELEASE LEVEL:  
DWG VERSION NO:

WEIGHT  
0.0 lbs  
MODEL NAME  
SE310-030-HH7  
WELDING  
ENGINEER

PART NO.	DRAWING NO.	NOMENCLATURE OR DESCRIPTION	MATERIAL	QTY RECD	SEE NOTES
PARTS LIST					
COMPUTER GENERATED DRAWING CHANGES NOT PERMITTED					
CENTRAL FILES: PRINCETON PLASMA PHYSICS LABORATORY					
UNLESS OTHERWISE SPECIFIED NATIONAL COMPACT STELLARATOR EXPERIMENT					
DIMENSIONS ARE IN INCHES MACHINE SURFACES UNLESS OTHERWISE SPECIFIED					
BREAK SHARP EDGES .005/ .020					
TOLERANCES NON-CUMULATIVE					
DECIMAL-INCH FRACTIONS		DSN: T. BROWN		1/12/06 DRAWING NO:	
NEXT ASSEMBLY		CHK: J. RUSHINSKI		1/12/06 SE310-030-A.Q	
.XX +/- .000		12" - 12" +/- .000		ENGR: G. LABIK	
.XXX +/- .005		72" - 120" +/- .005		1/12/06 SUPV: J. SIEGEL	
ANGULAR +/- .015		OVER 120" +/- .012		SHEET 13 OF 15 REV 0	

NCSX-SE310-030-A.Q

NO.	REVISION	BY	CH	SUP	APPROVED	DATE

FOR NOTES SEE SHEET 1

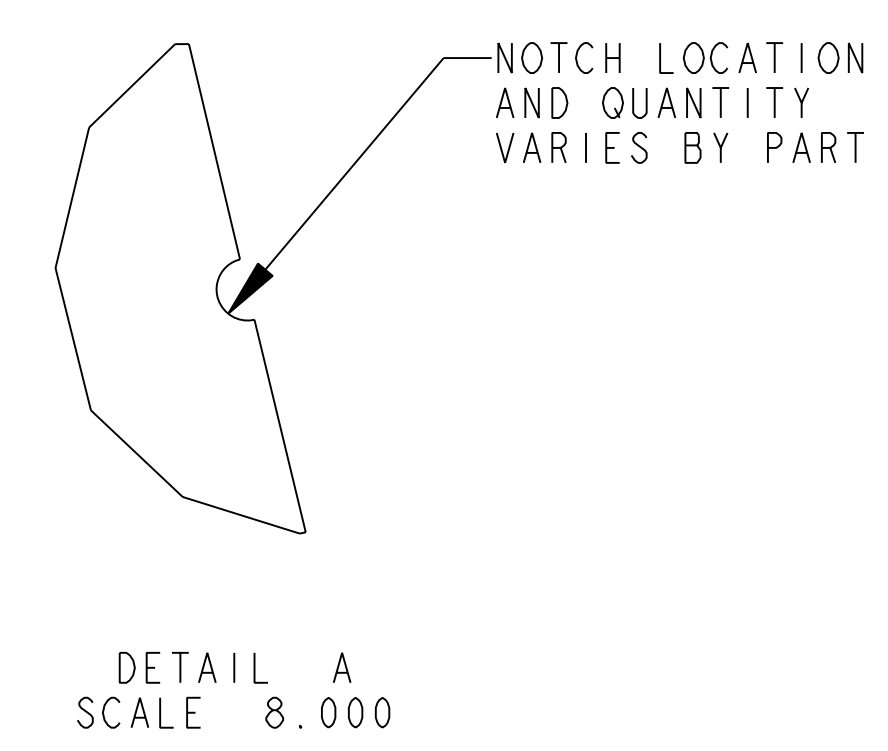
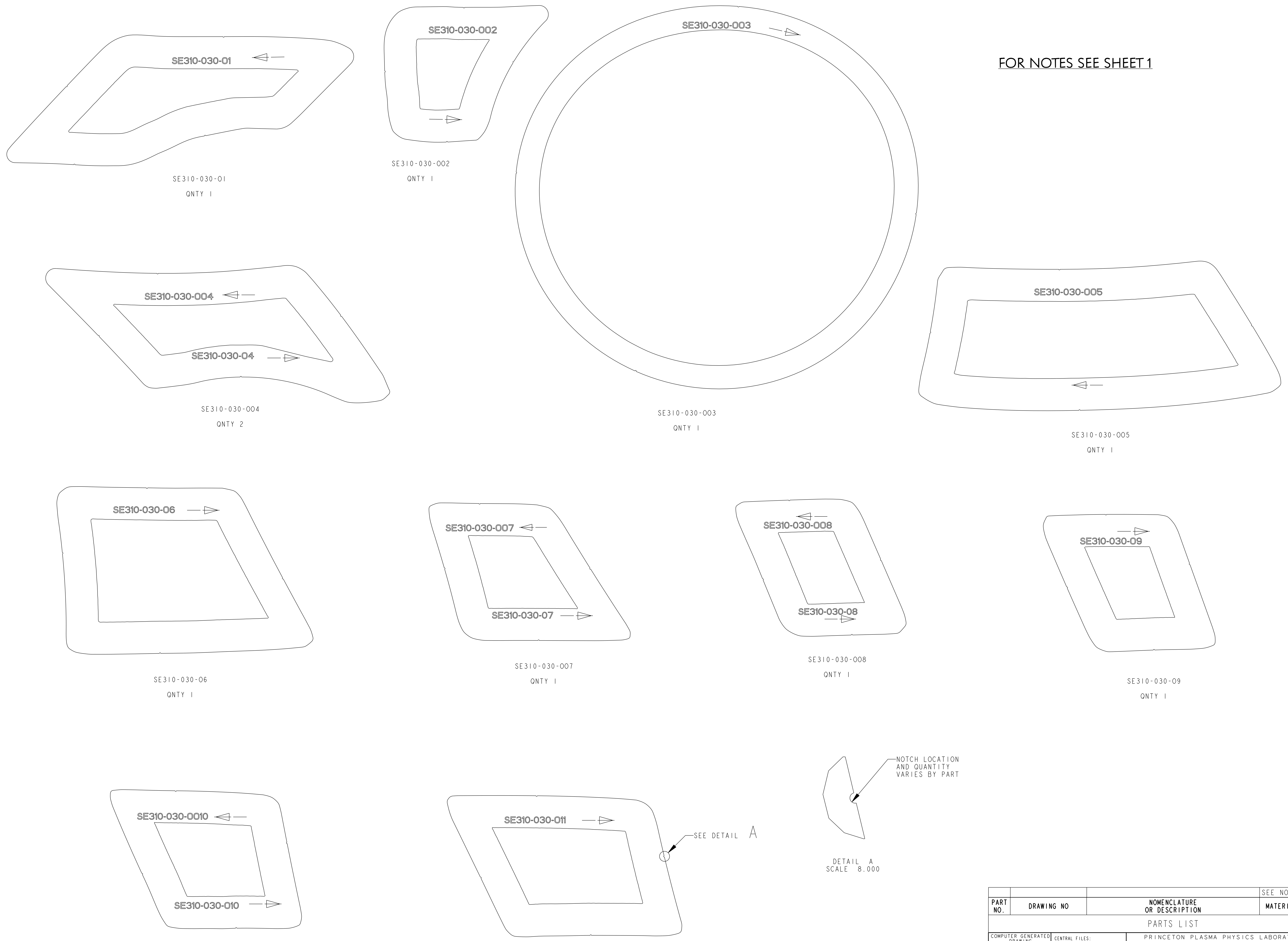

RELEASE LEVEL:  
DWG VERSION NO:

WEIGHT  
0.0 lbs  
MODEL NAME  
SE 310-030-HH7  
WELDING  
ENGINEER

PART NO.	DRAWING NO	NOMENCLATURE OR DESCRIPTION	MATERIAL	QTY REOD	SEE NOTES
PARTS LIST					
COMPUTER GENERATED DRAWING MANUAL CHANGES NOT PERMITTED Pro E		CENTRAL FILES: UNLESS OTHERWISE SPECIFIED DIMENSIONS ARE IN INCHES MACHINE SURFACES BREAK SHARP EDGES .005/.020	PRINCETON PLASMA PHYSICS LABORATORY PRINCETON UNIVERSITY <b>NATIONAL COMPACT STELLARATOR EXPERIMENT</b> DIAGNOSTICS MAGNETIC DIAGNOSTICS MAGNETIC LOOP SERIES "O"		
DO NOT VERIFY INFORMATION BY SCALING DRAWING	TOLERANCES NON-CUMULATIVE	DSN: T. BROWN	1/12/06	DRAWING NO:	
NEXT ASSEMBLY	DECIMAL-INCH FRACTIONS	CHK: J. RUSHINSKI	1/12/06	<b>SE310-030-A.Q</b>	
	.XX +/- .000 0°-12° +/- .004 .XXX +/- .005 12°-120° +/- .008 ANGULAR +/- .0°-15° OVER 120° +/- .012	ENGR: G. LABIK	1/12/06		
		SUPV: J. SIEGEL	1/12/06	SHEET 14 OF 15 REV 0	

NCSX-SE310-030-A.Q

NO.	REVISION	BY	CH	SUP	APPROVED	DATE

FOR NOTES SEE SHEET 1

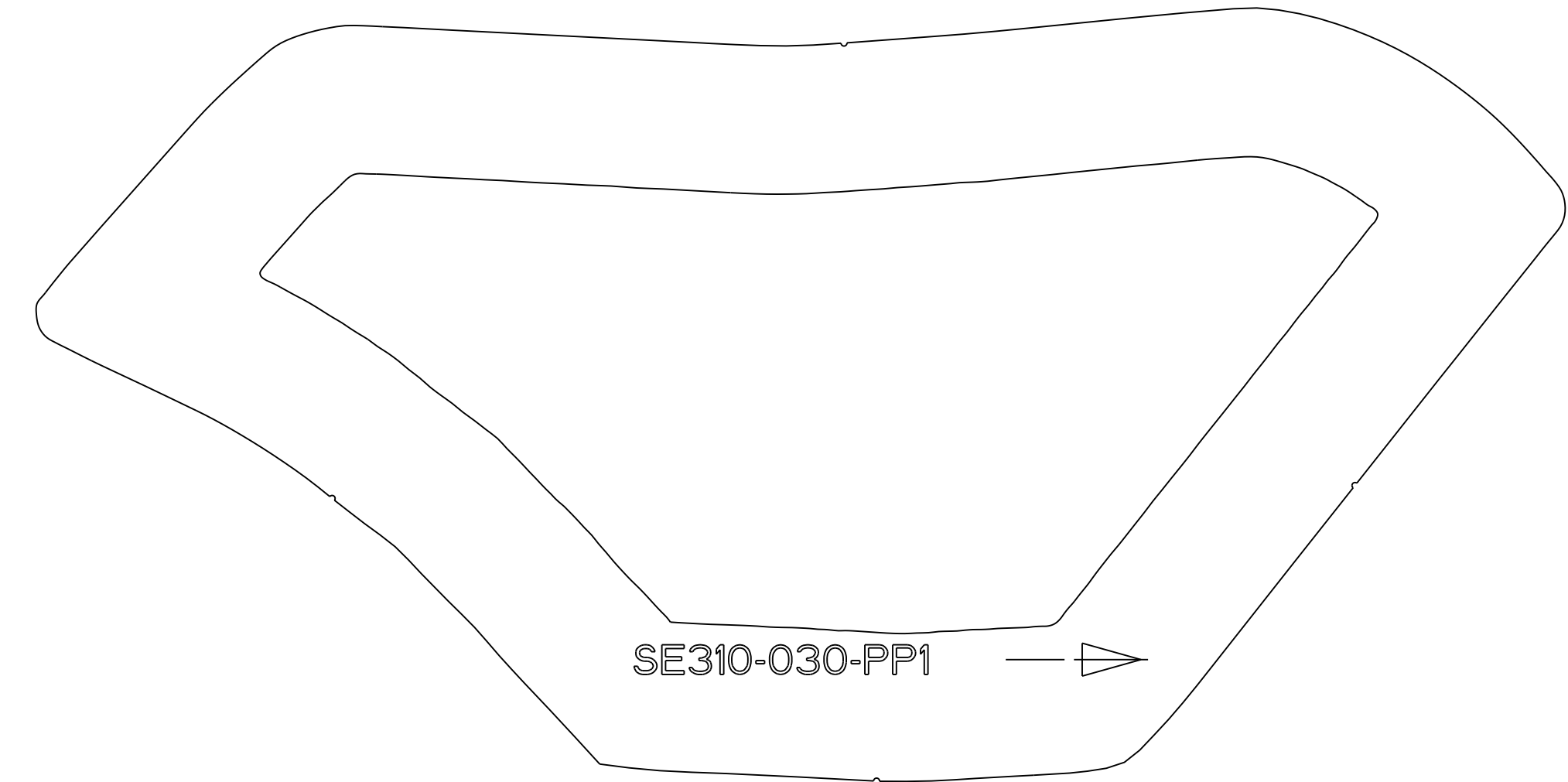

SE310-030-PP1

SE310-030-PP1  
QNTY 1

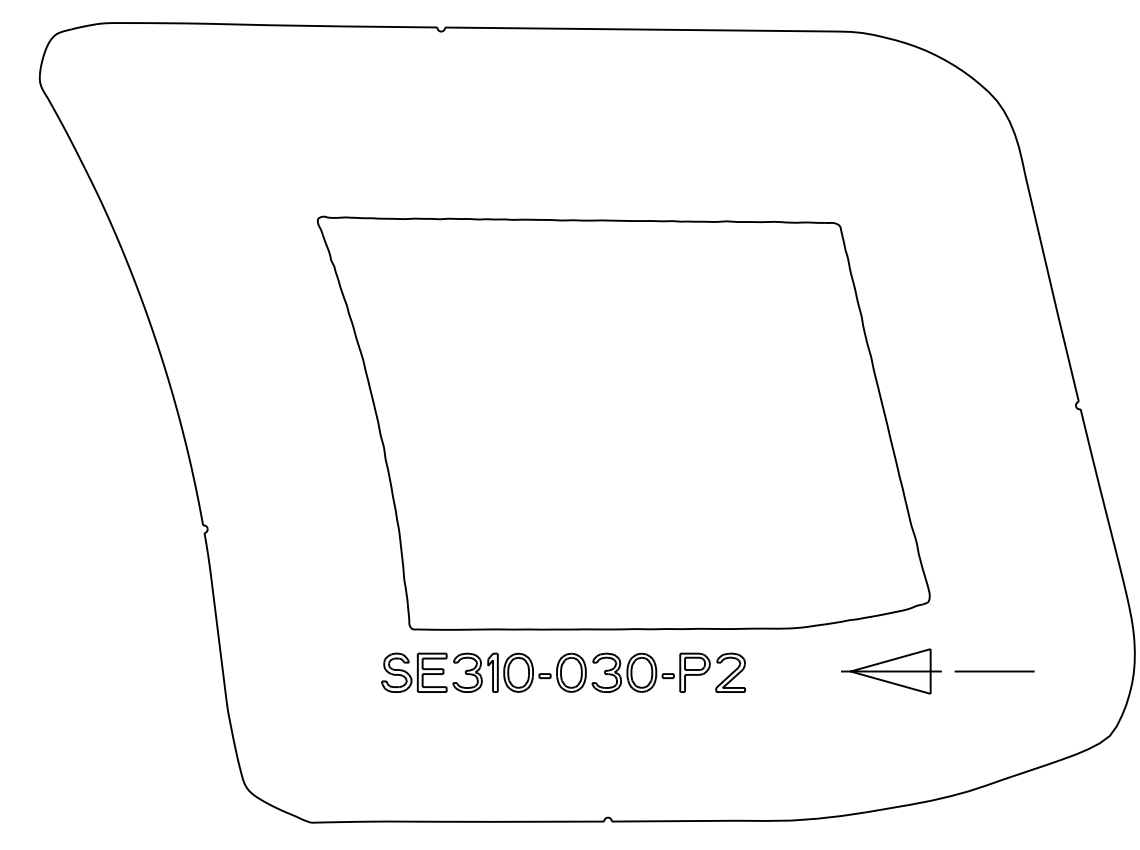

SE310-030-P2

SE310-030-P2  
QNTY 1

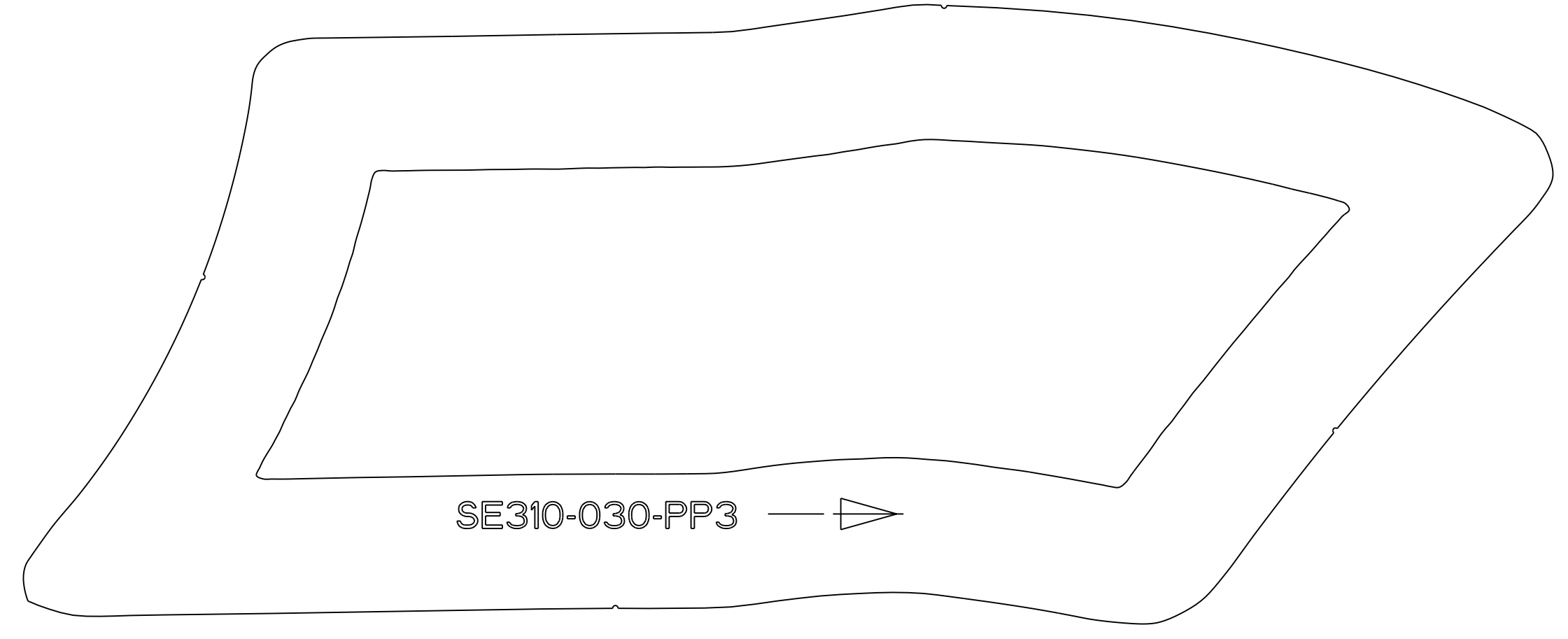

SE310-030-PP3

SE310-030-PP3  
QNTY 1

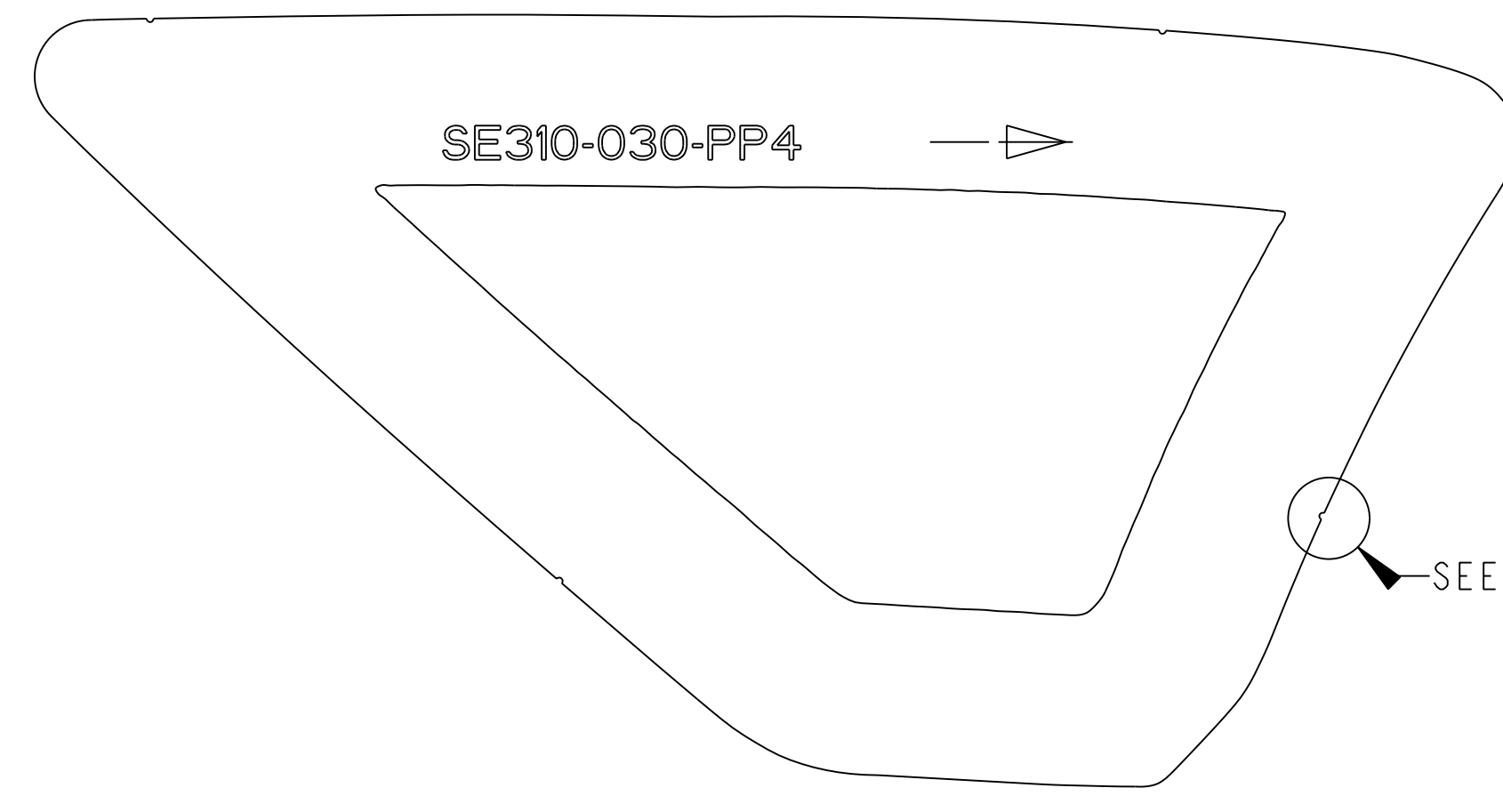

SE310-030-PP4

SE310-030-PP4  
QNTY 1

SEE DETAIL A

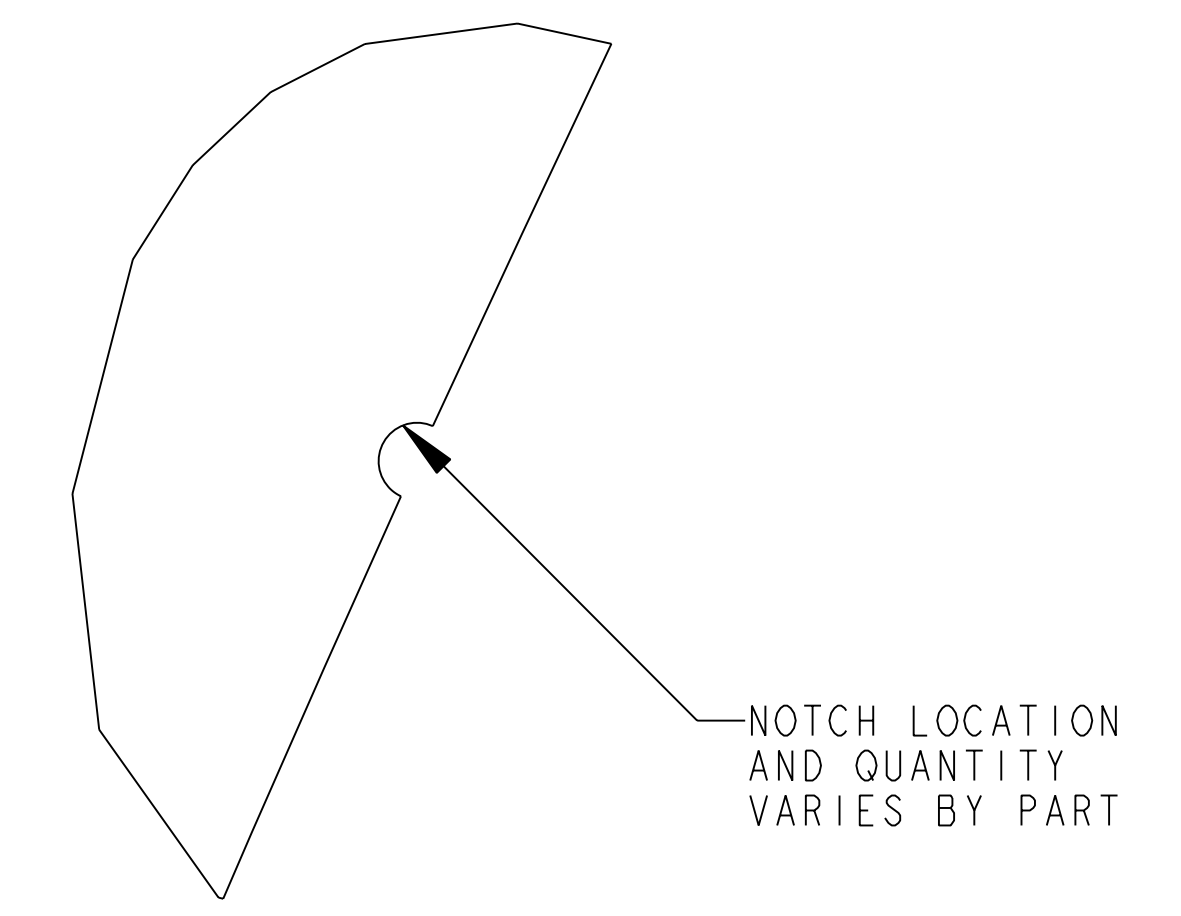

NOTCH LOCATION AND QUANTITY VARIES BY PART

DETAIL A  
SCALE 10.000

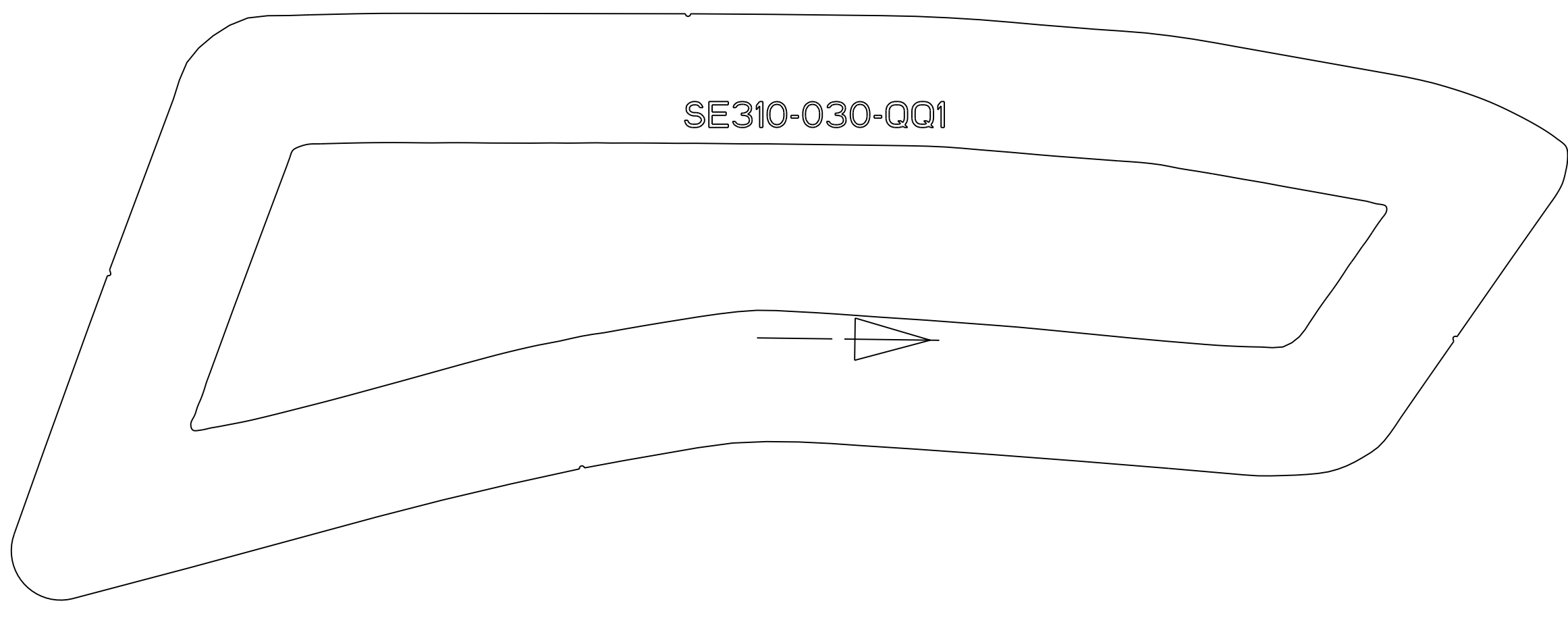

SE310-030-QQ1

SE310-030-QQ1  
QNTY 1

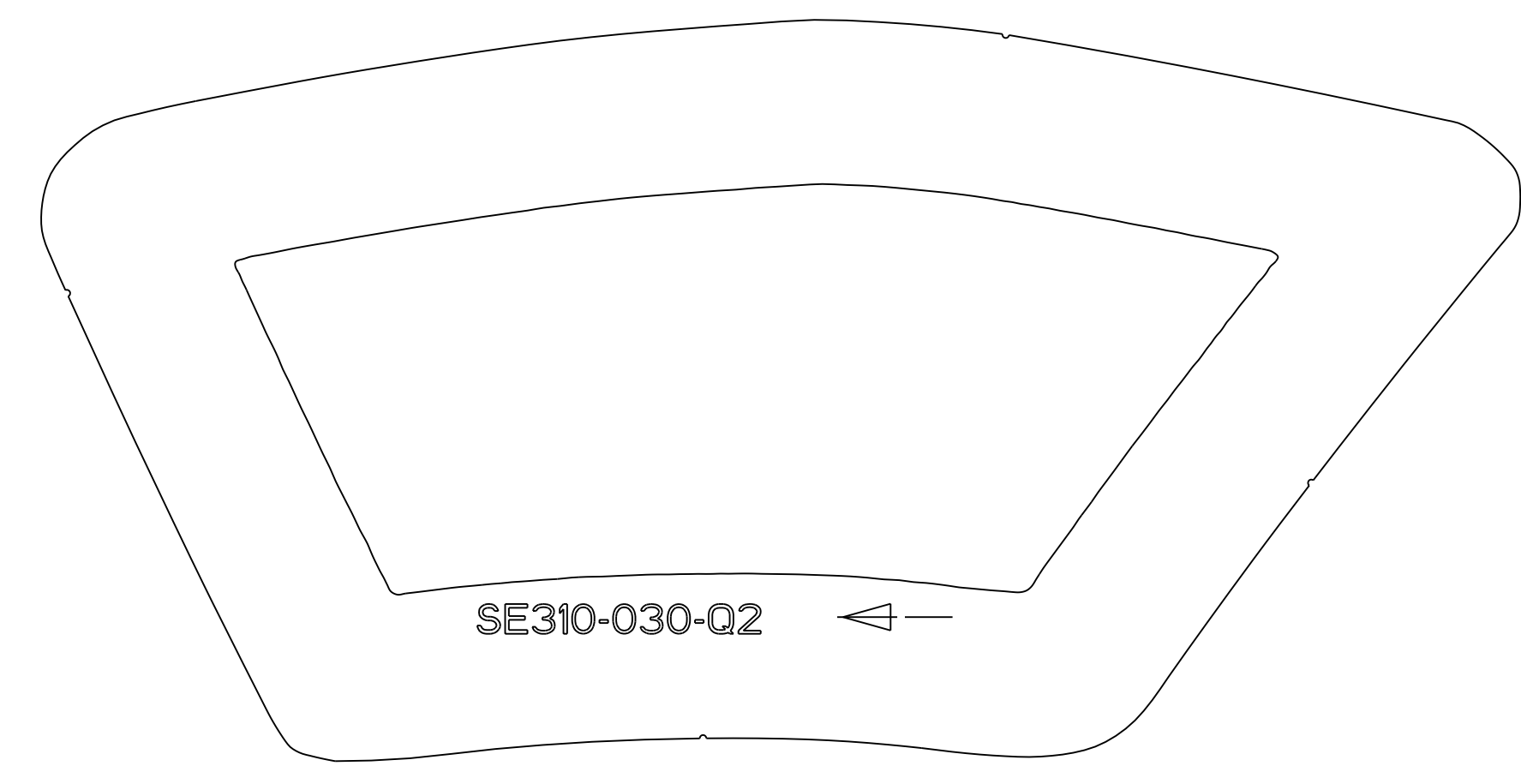

SE310-030-Q2

SE310-030-Q2  
QNTY 1

PART NO.	DRAWING NO.	NOMENCLATURE OR DESCRIPTION	MATERIAL	QTY RECD	SEE NOTES
		PARTS LIST			
COMPUTER GENERATED DRAWING DRAWING CHANGES NOT PERMITTED	CENTRAL FILES:	PRINCETON PLASMA PHYSICS LABORATORY PRINCETON UNIVERSITY			
Pro E	UNLESS OTHERWISE SPECIFIED	NATIONAL COMPACT STELLARATOR EXPERIMENT			
DO NOT VERIFY INFORMATION BY SCALING DRAWING	DIMENSIONS ARE IN INCHES MACHINE SURFACES	DIAGNOSTICS MAGNETIC DIAGNOSTICS MAGNETIC LOOPS SERIES "P AND Q"			
	BREAK SHARP EDGES .005/.020	TOLERANCES NON-CUMULATIVE			
		DSN: T. BROWN	DRAWING NO:		
NEXT ASSEMBLY	DECIMAL-INCH FRACTIONS	CHK:	SE310-030-A.Q		
	.XX +/- .000 0°-12° +/- .010	ENGR: G. LABIK	SHEET 15 OF 15 REV 0		
	.XXX +/- .005 12°-120° +/- .100	SUPV:	NCSX-PART-FORMAT.E		
	ANGULAR +/- .0°-15° OVER 120° +/- .100				

WEIGHT  
0.0 lbs

MODEL NAME  
SE310-030-HH7

WELDING ENGINEER

RELEASE LEVEL:  
DWG VERSION NO:

NCSX-SE310-030-A.Q