

SECTION C-C

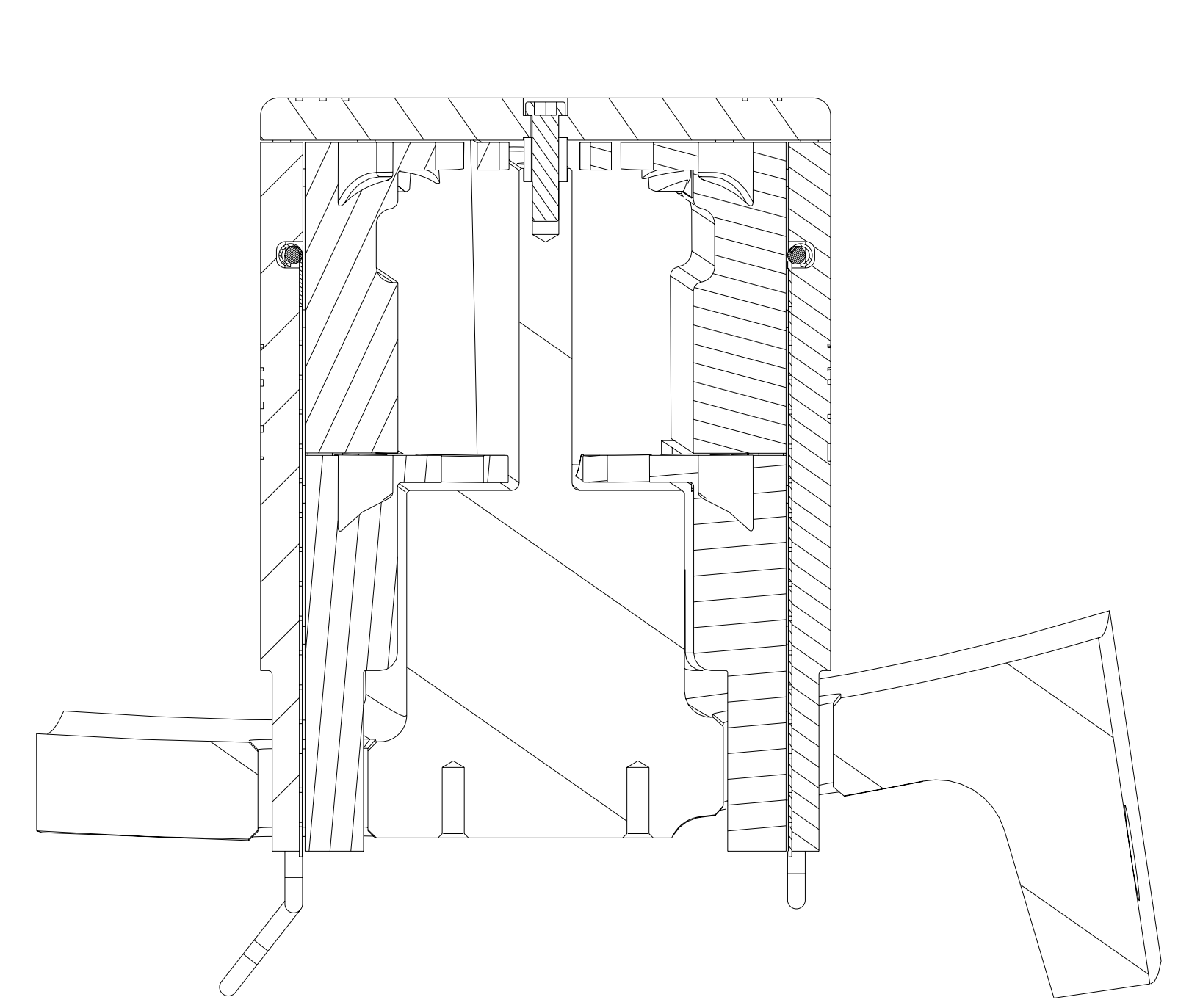

SECTION A-A

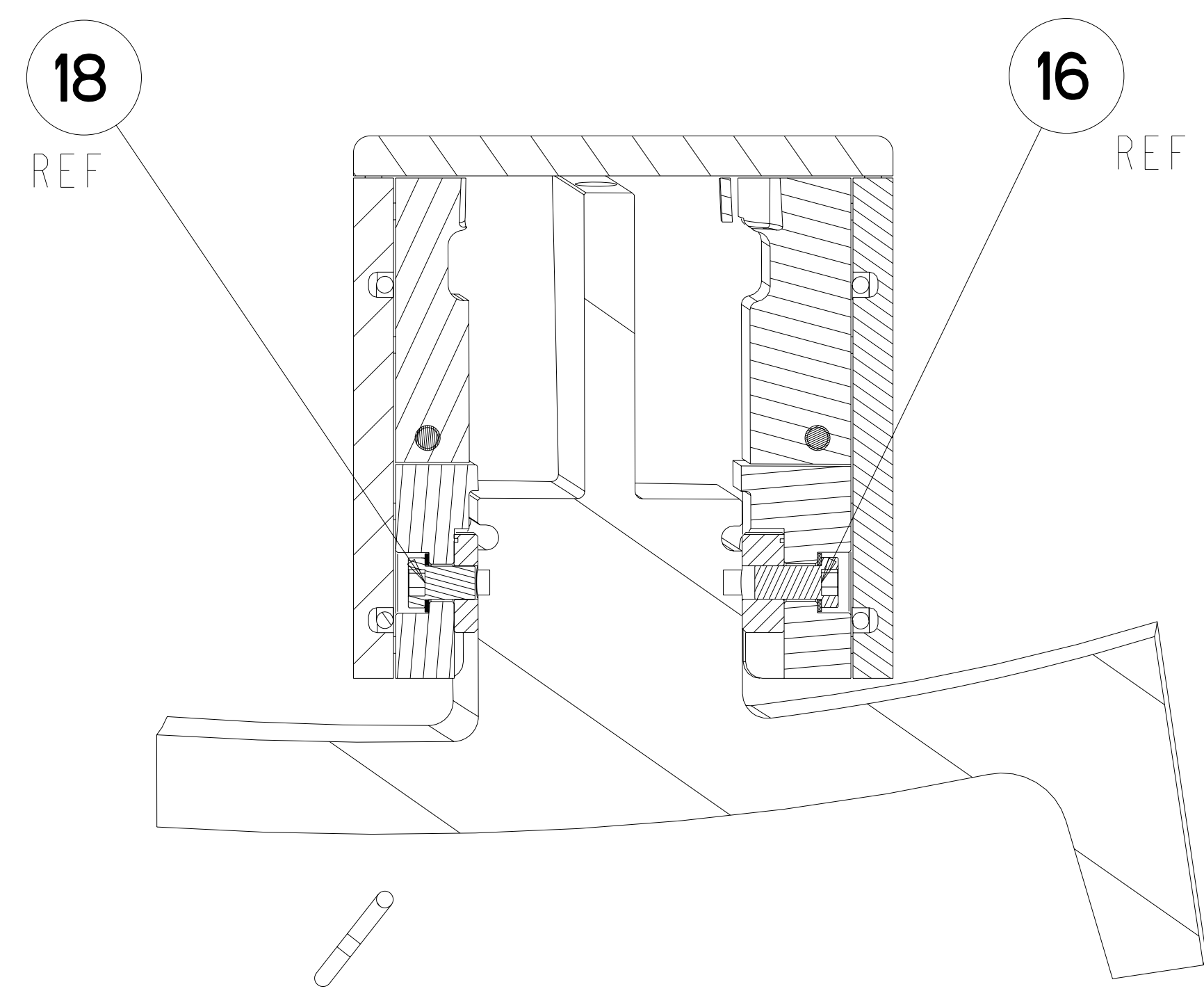

SECTION B-B

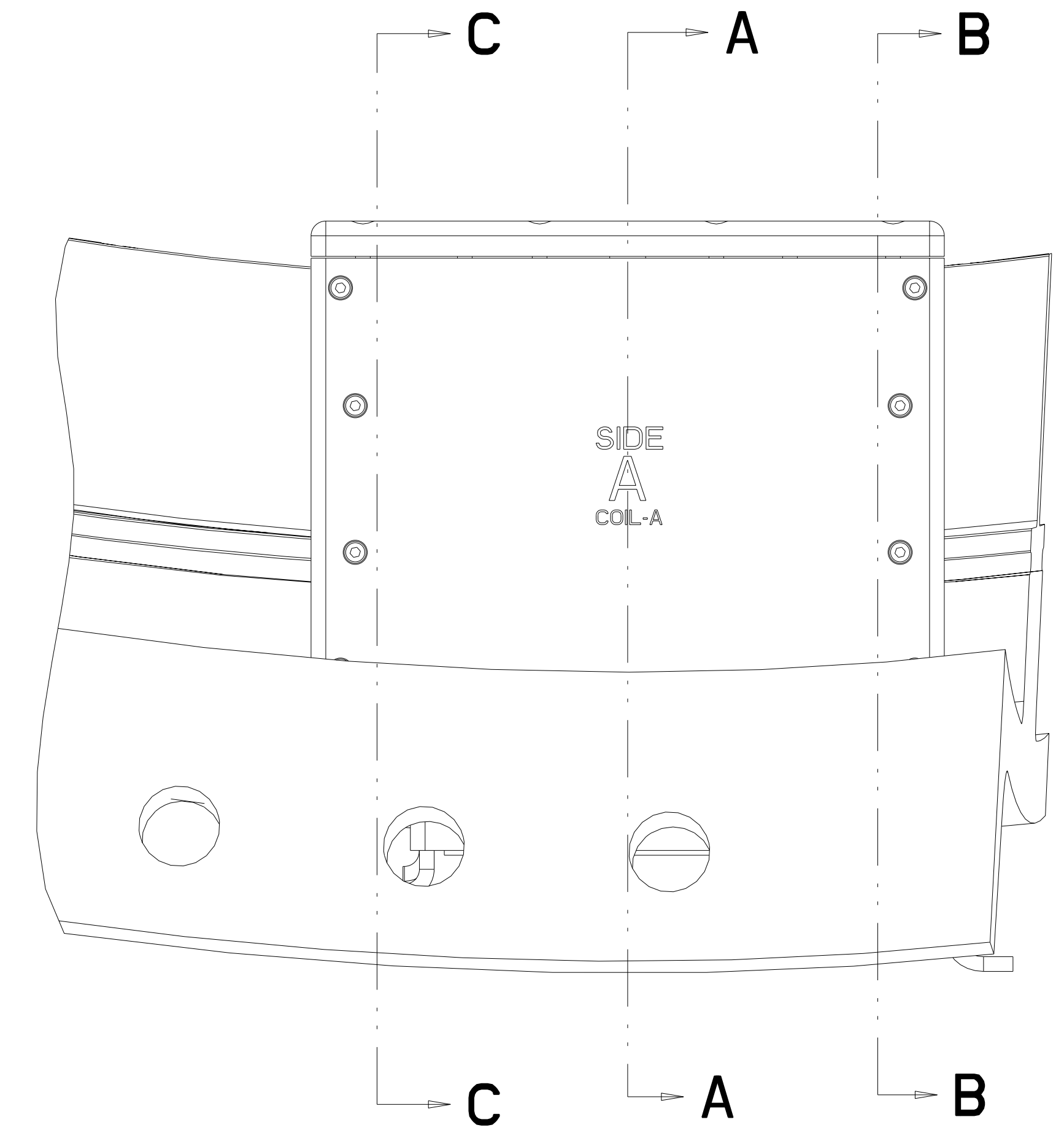

SIDE VIEW
SCALE 0.50

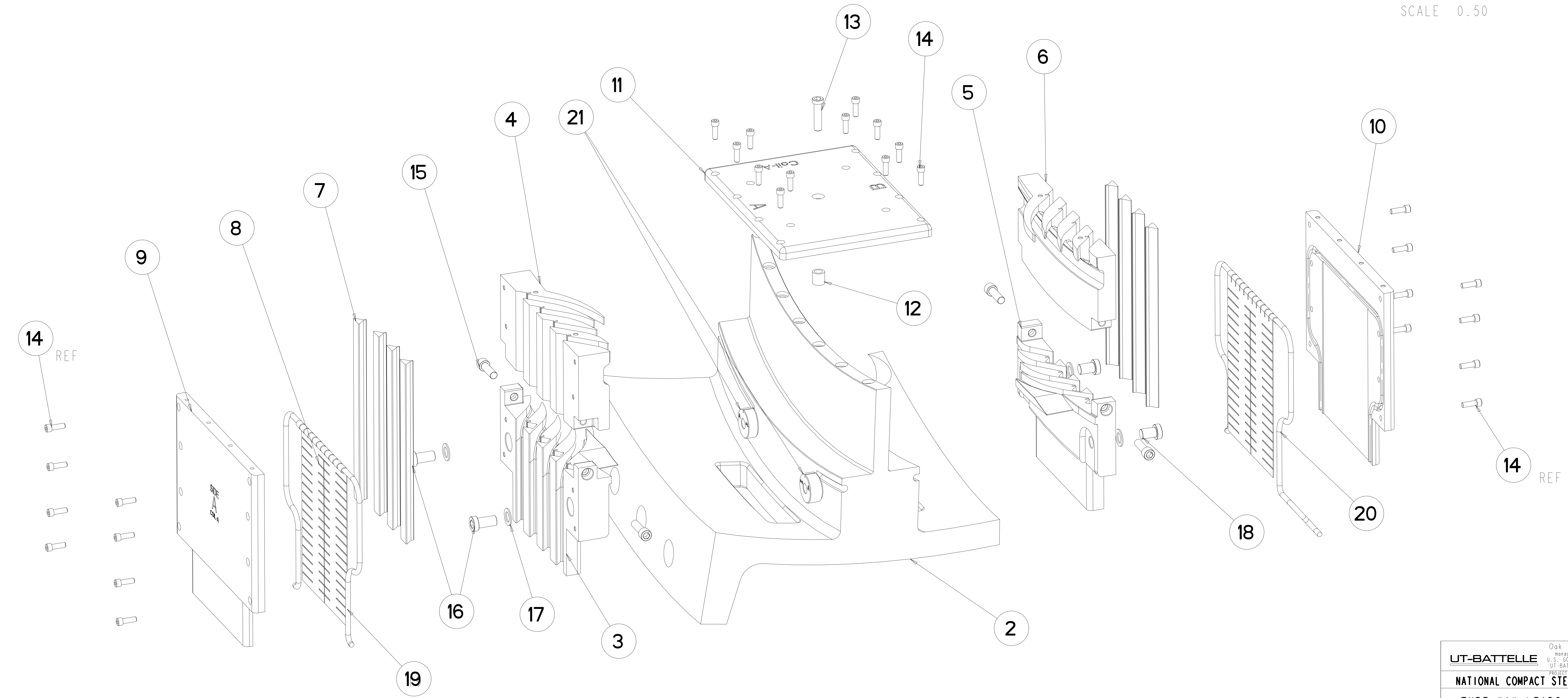

EXPLODED VIEW
SCALE 0.50

Oak Ridge National Laboratory managed for the DEPARTMENT OF ENERGY under U.S. GOVERNMENT contract DE-AC05-00OR22725 UT-BATTELLE, LLC, Oak Ridge, Tennessee PROJECT NAME									
UT-BATTELLE NATIONAL COMPACT STELLARATOR EXPERIMENT									
TYPE "A" LEADS WINDING BLOCKS ASSEMBLY									
VERSION NO.	PLANT	BLDG	FL	SHT	OF	TYPE	CLASS		
24+	X-10	5700	3	2	2	S	U		
RELEASE LEVEL		SE142A-080						REV	
WIP								0	

H
G
F
E
D
C
B
A

H
G
F
E
D
C
B
A

8 7 6 5 4 3 2 1

8 7 6 5 4 3 2 1

080-080