

INSTANCE: SEI42C-482_FLAT_125
INSTANCE: SEI42C-482_FLAT_124

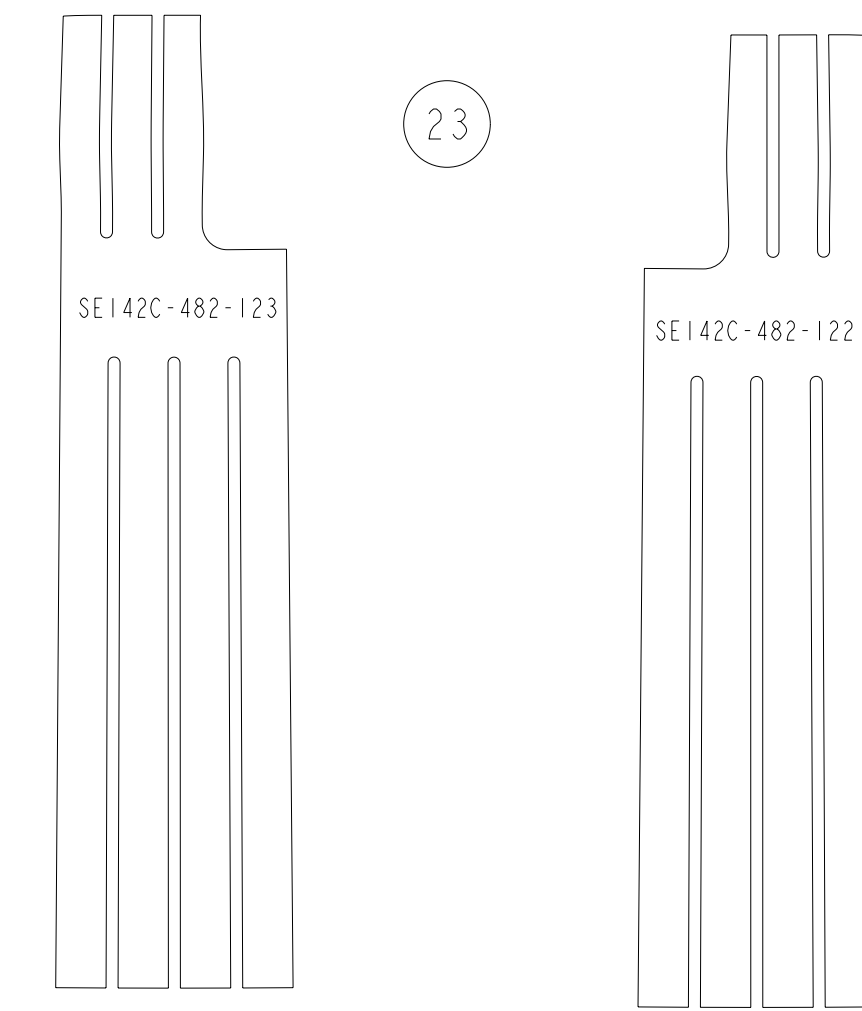

INSTANCE: SEI42C-482_FLAT_123
INSTANCE: SEI42C-482_FLAT_122

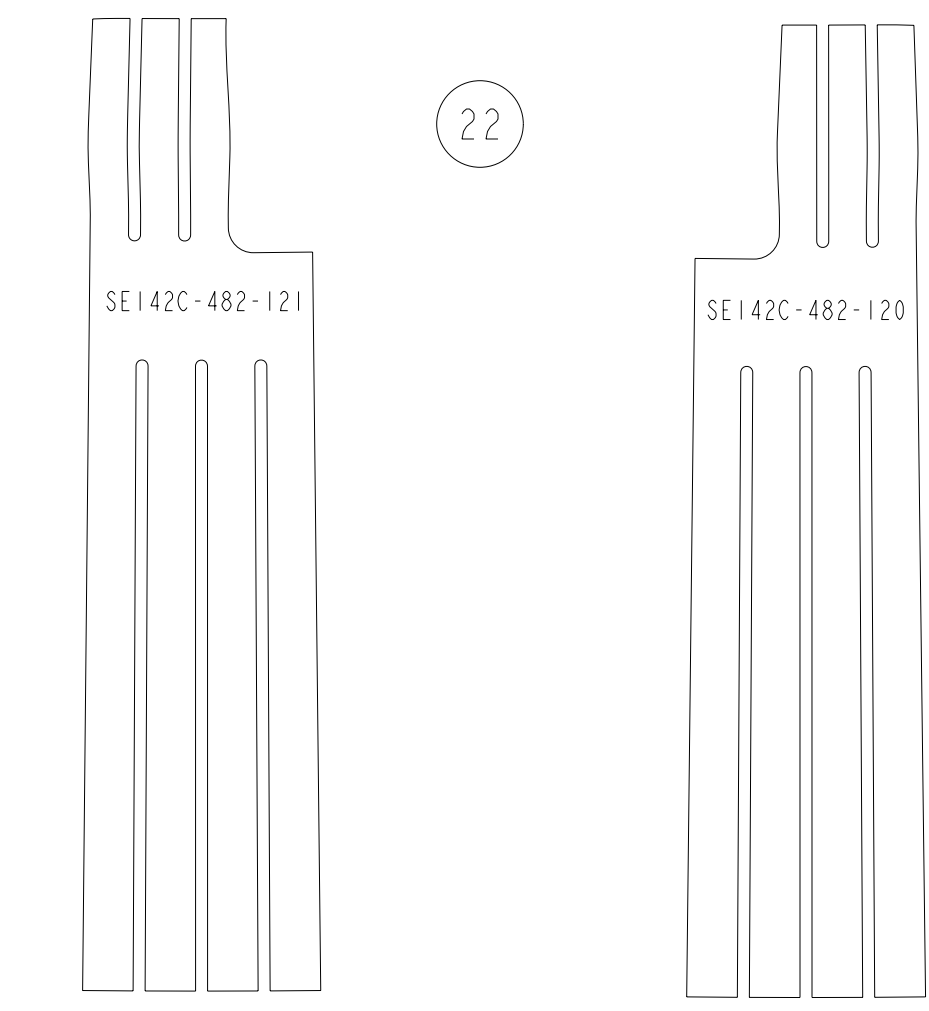

INSTANCE: SEI42C-482_FLAT_121
INSTANCE: SEI42C-482_FLAT_120

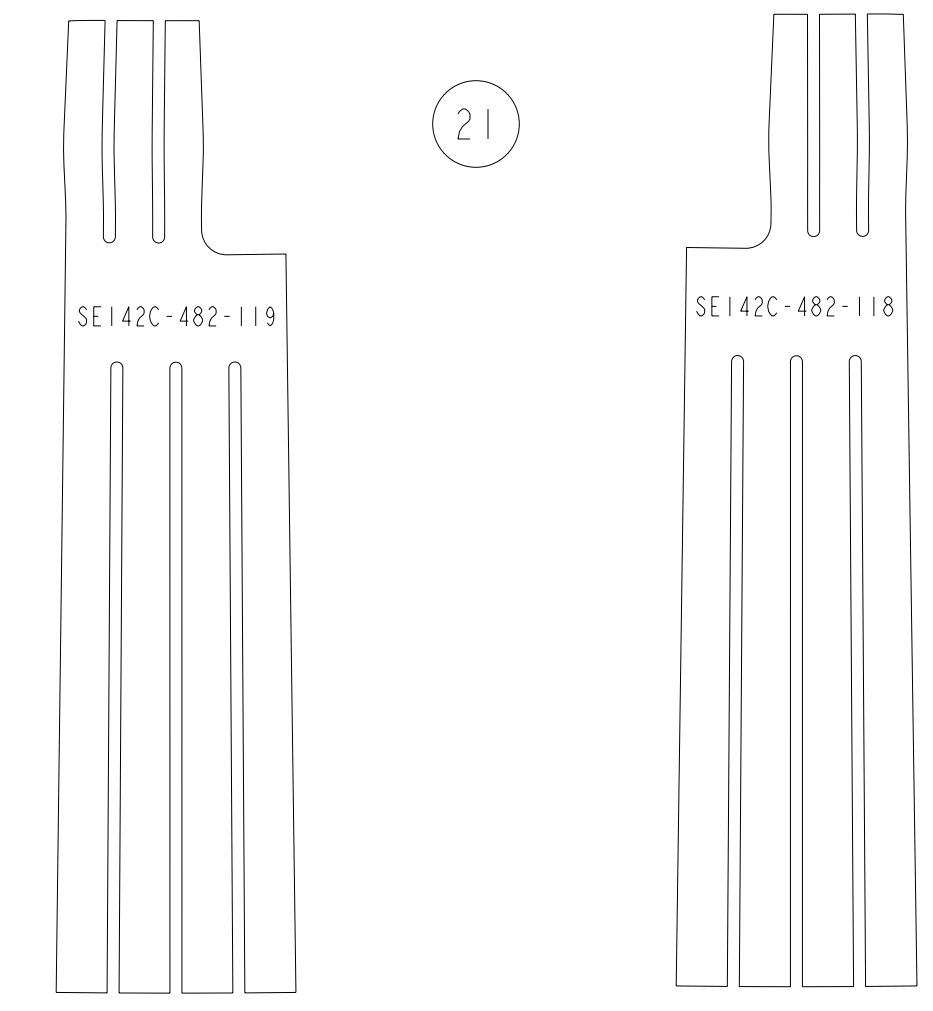

INSTANCE: SEI42C-482_FLAT_119
INSTANCE: SEI42C-482_FLAT_118

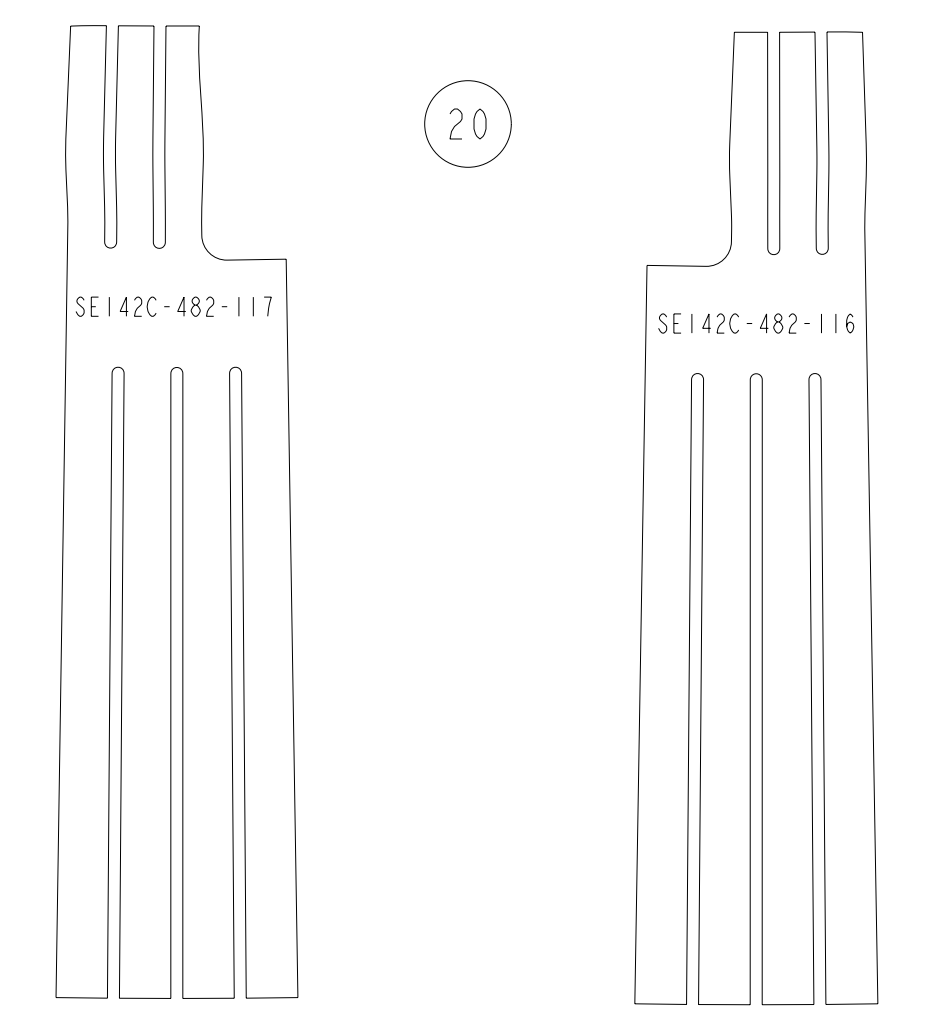

INSTANCE: SEI42C-482_FLAT_117
INSTANCE: SEI42C-482_FLAT_116

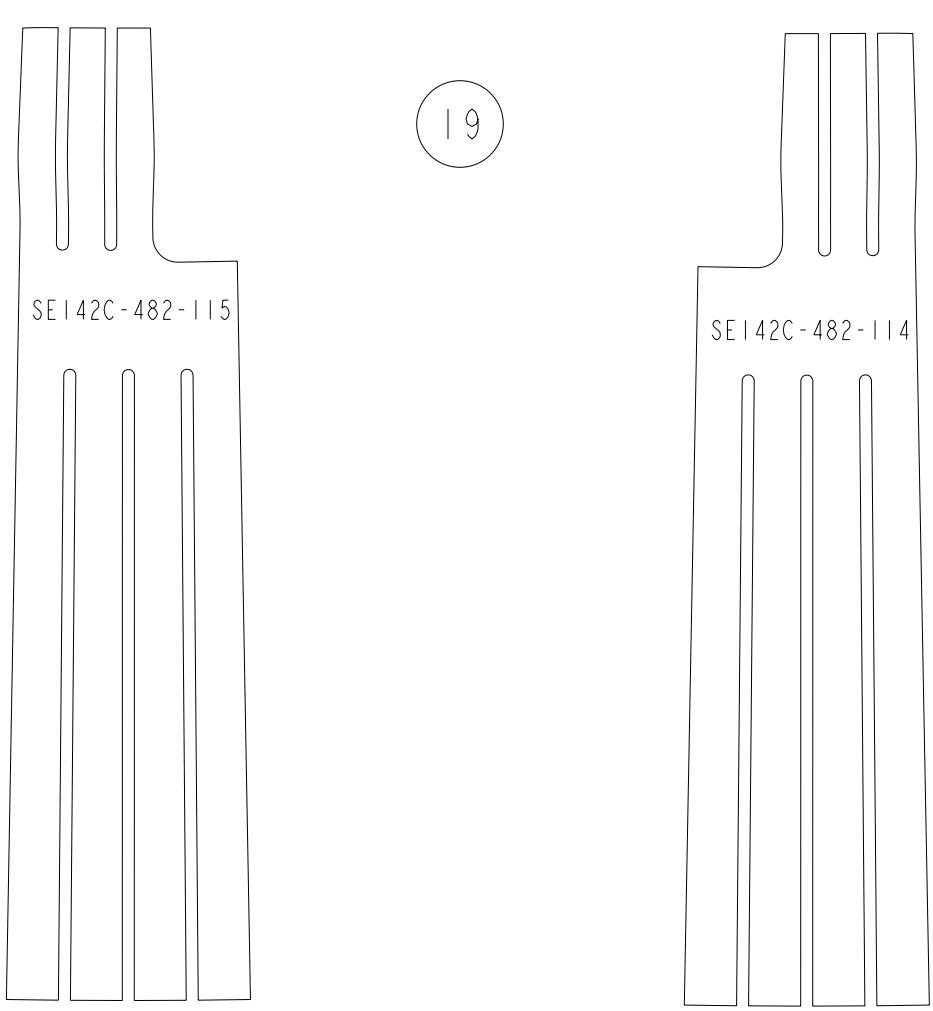

INSTANCE: SEI42C-482_FLAT_115
INSTANCE: SEI42C-482_FLAT_114

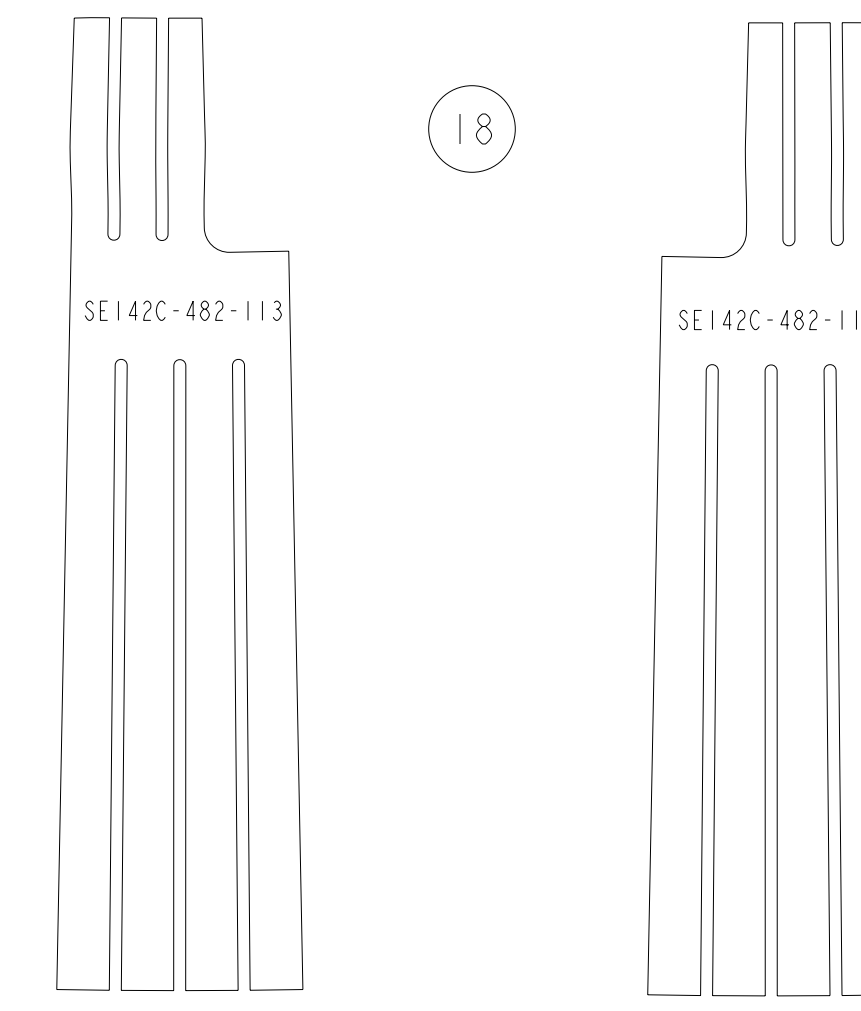

INSTANCE: SEI42C-482_FLAT_113
INSTANCE: SEI42C-482_FLAT_112

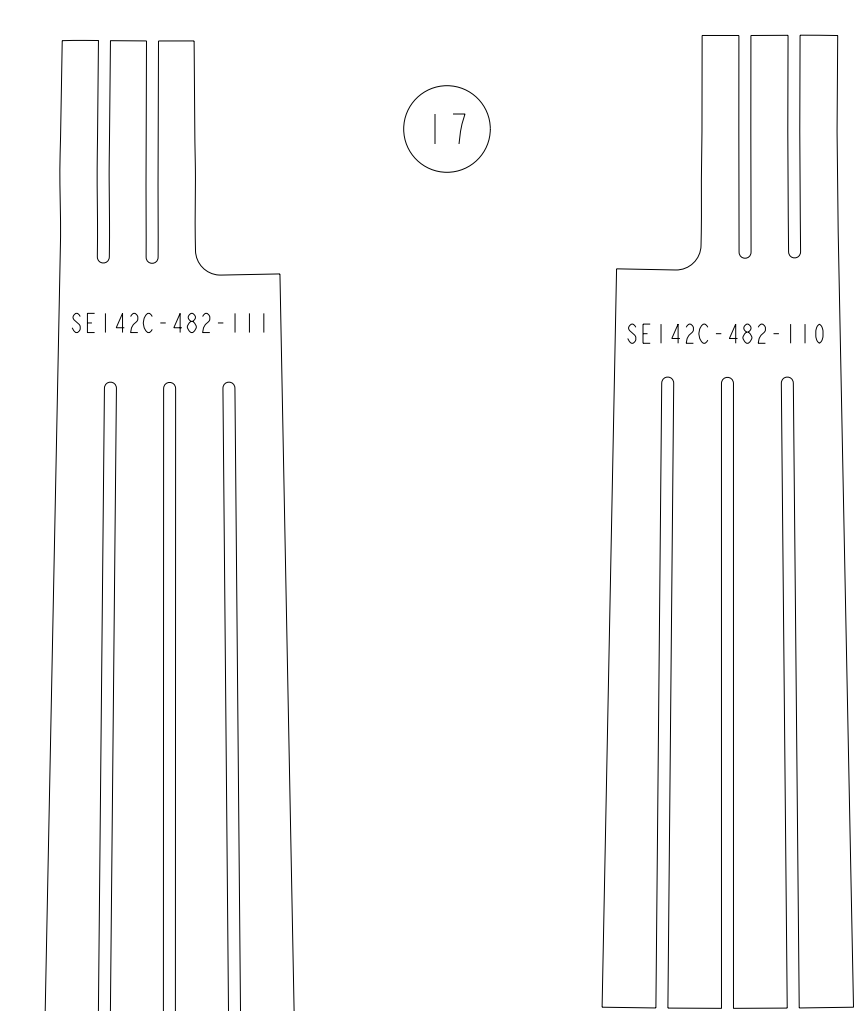

INSTANCE: SEI42C-482_FLAT_111
INSTANCE: SEI42C-482_FLAT_110

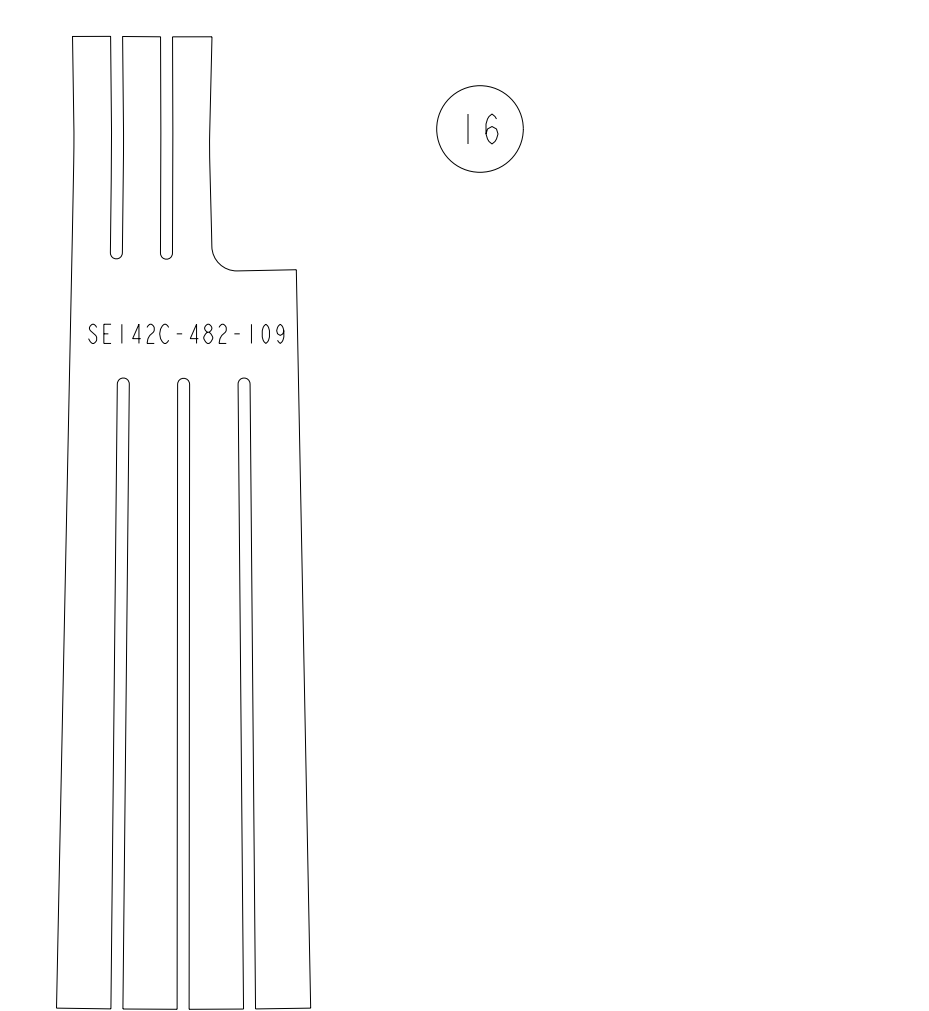

INSTANCE: SEI42C-482_FLAT_109

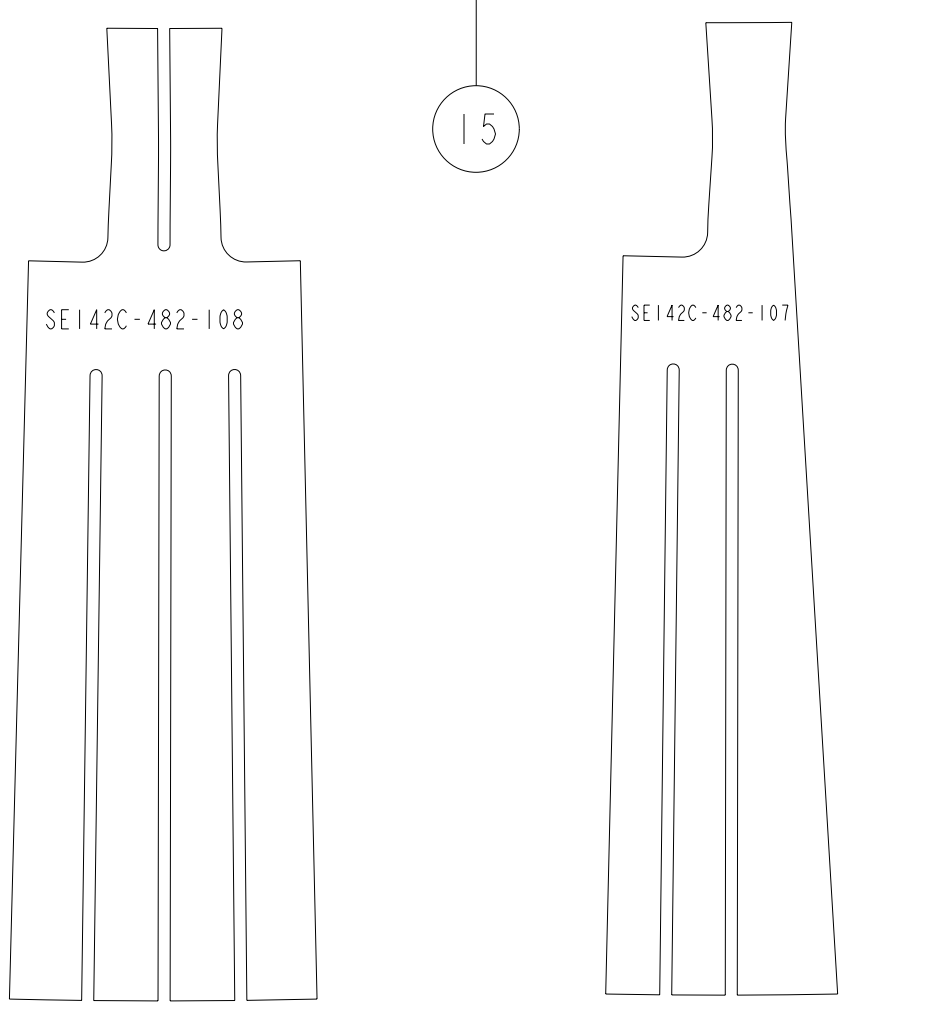

INSTANCE: SEI42C-482_FLAT_108-NEW
INSTANCE: SEI42C-482_FLAT_107-NEW

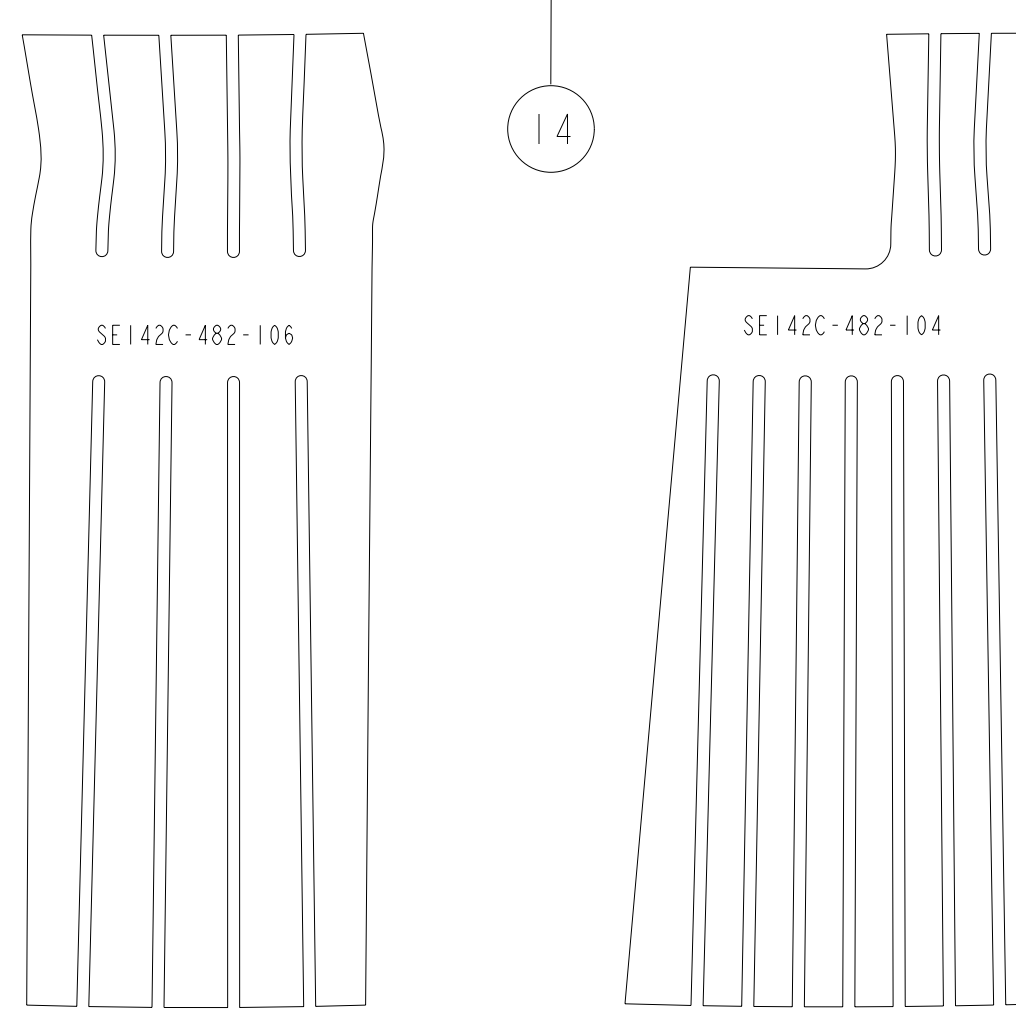

INSTANCE: SEI42C-482_FLAT_106-NEW
INSTANCE: SEI42C-482_FLAT_104-NEW

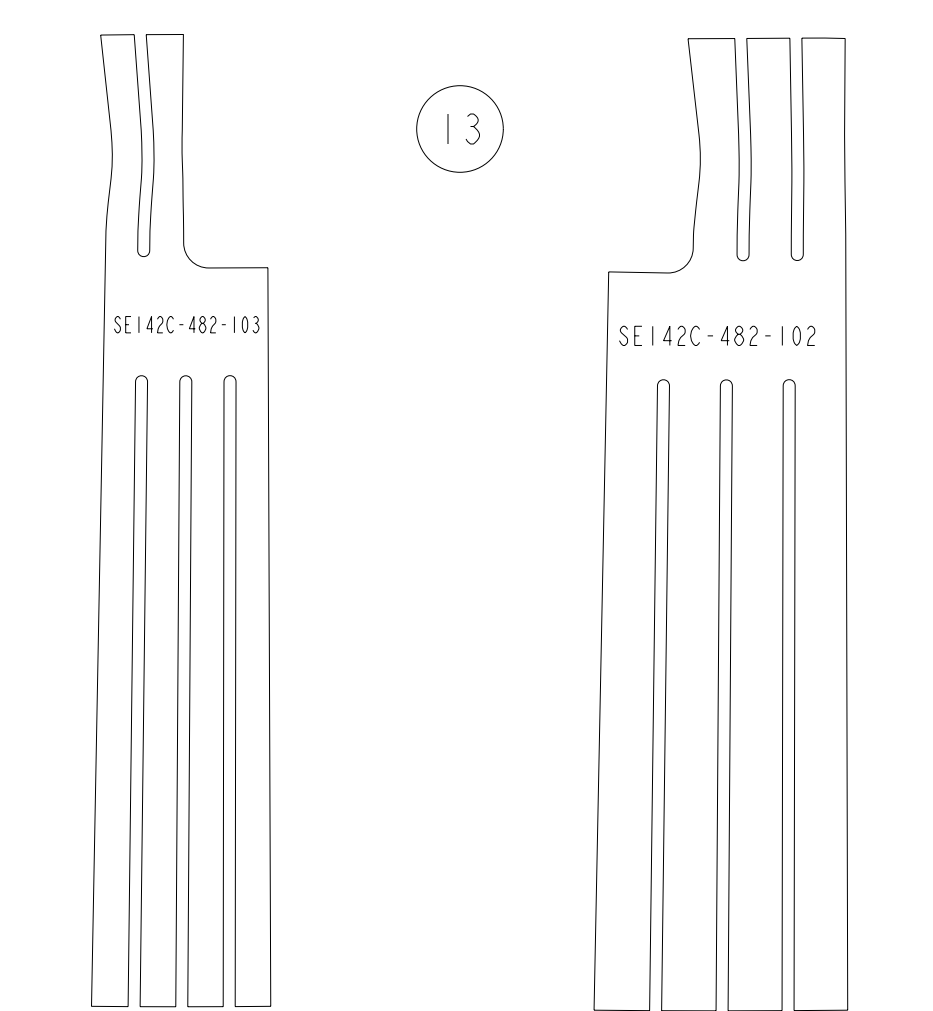

INSTANCE: SEI42C-482_FLAT_103-NEW
INSTANCE: SEI42C-482_FLAT_102-NEW

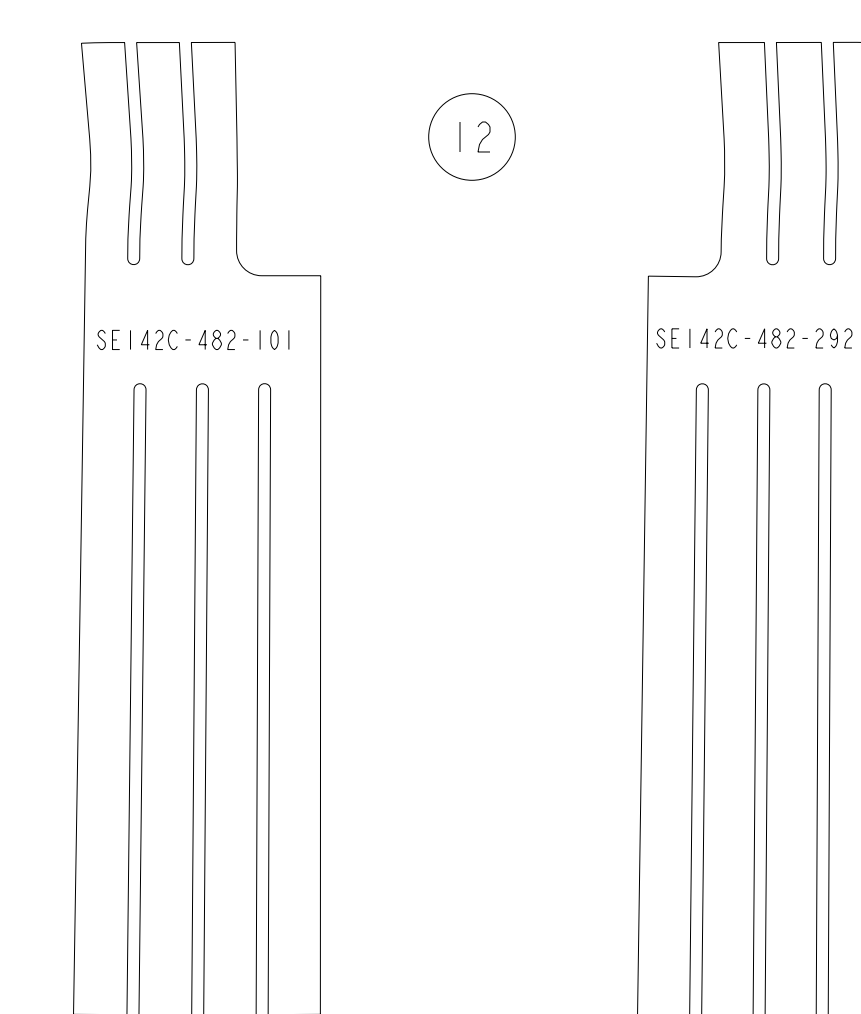

INSTANCE: SEI42C-482_FLAT_101
INSTANCE: SEI42C-482_FLAT_292-NEW

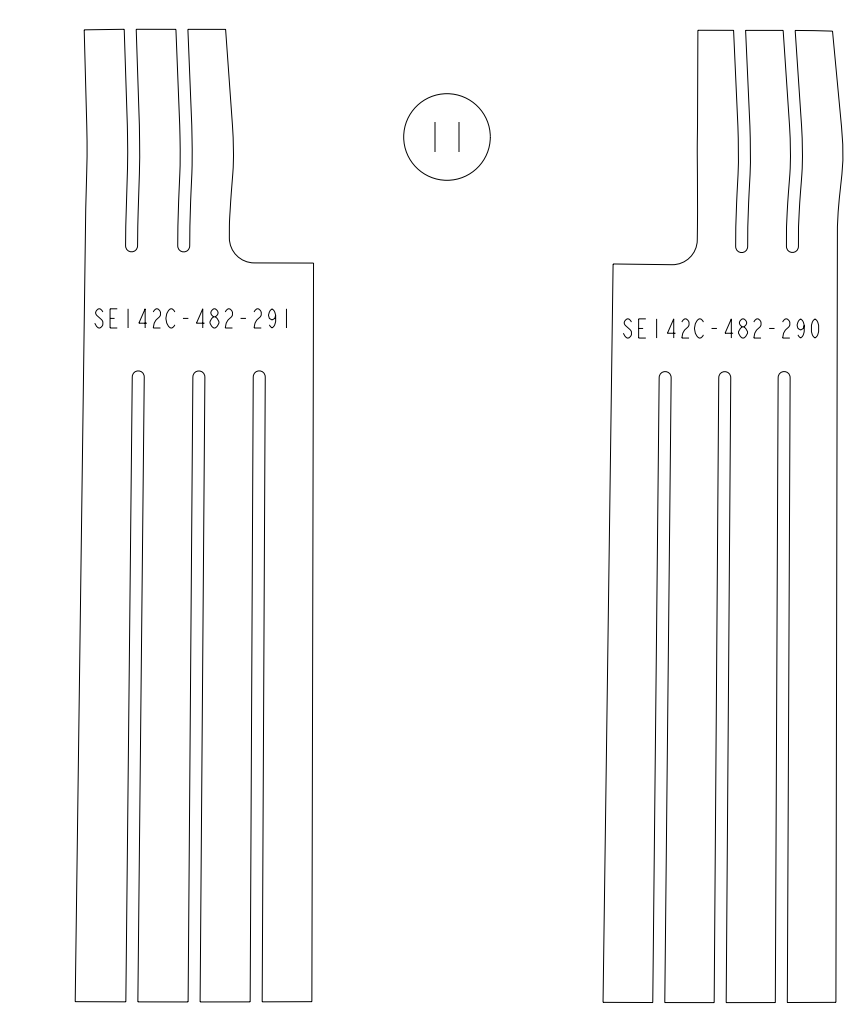

INSTANCE: SEI42C-482_FLAT_291
INSTANCE: SEI42C-482_FLAT_290

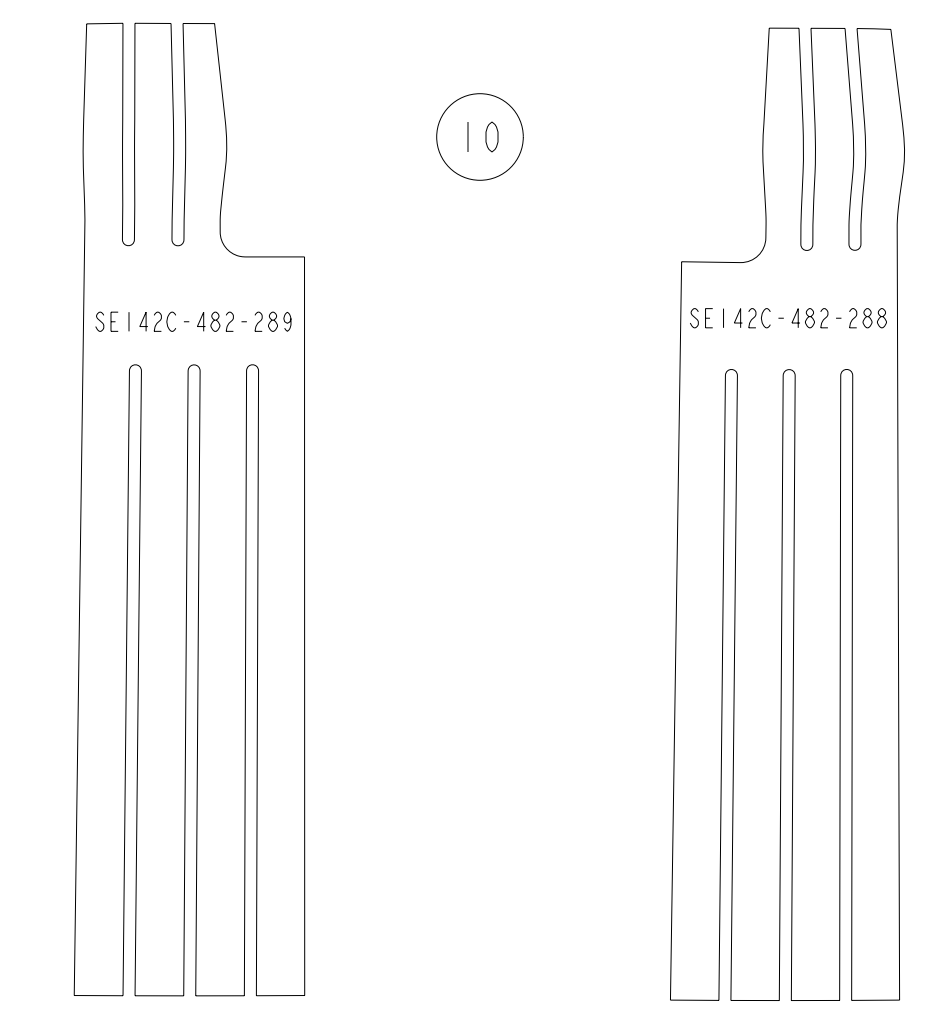

INSTANCE: SEI42C-482_FLAT_289
INSTANCE: SEI42C-482_FLAT_288

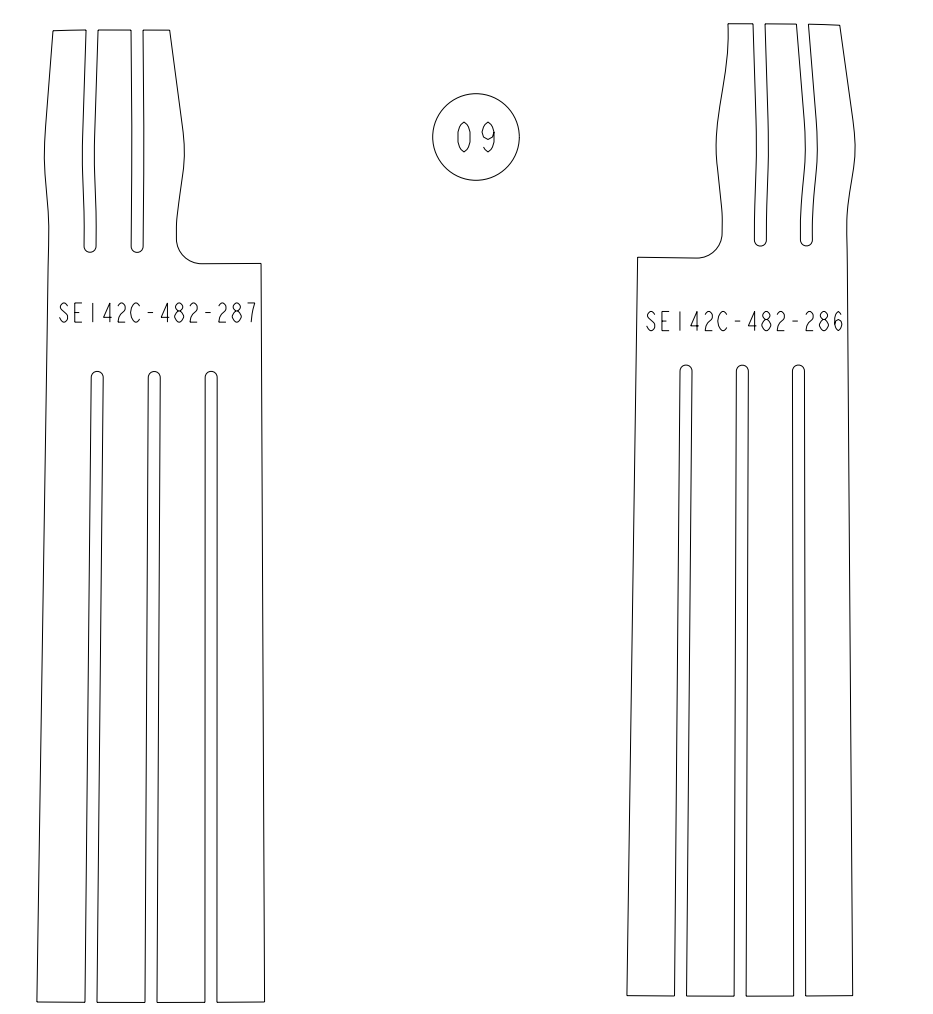

INSTANCE: SEI42C-482_FLAT_287
INSTANCE: SEI42C-482_FLAT_286

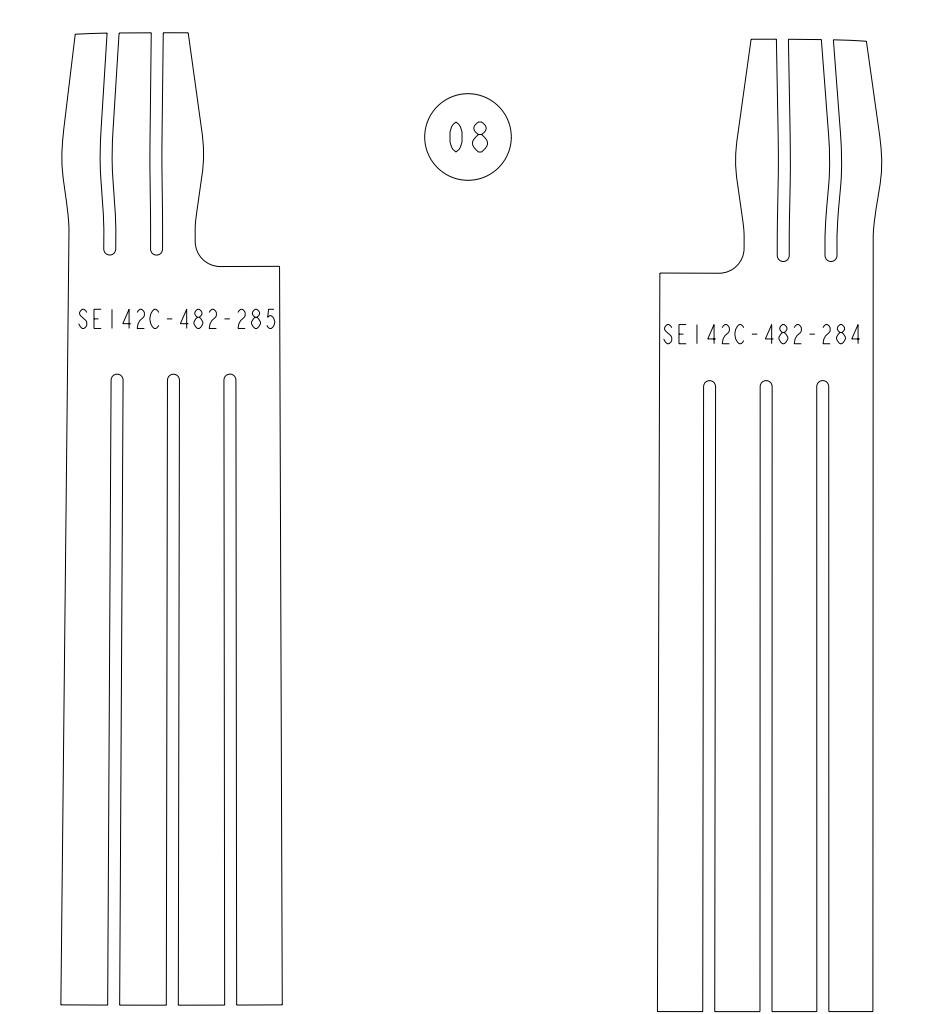

INSTANCE: SEI42C-482_FLAT_285
INSTANCE: SEI42C-482_FLAT_284

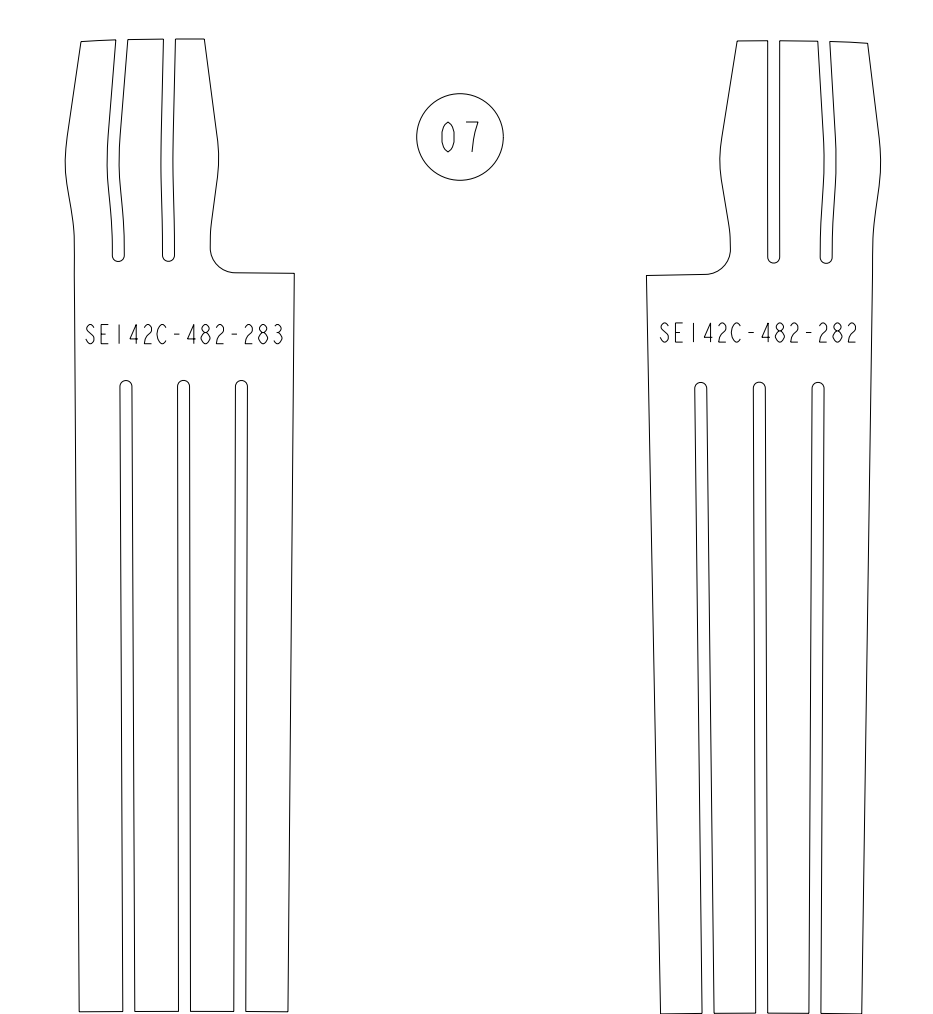

INSTANCE: SEI42C-482_FLAT_283
INSTANCE: SEI42C-482_FLAT_282

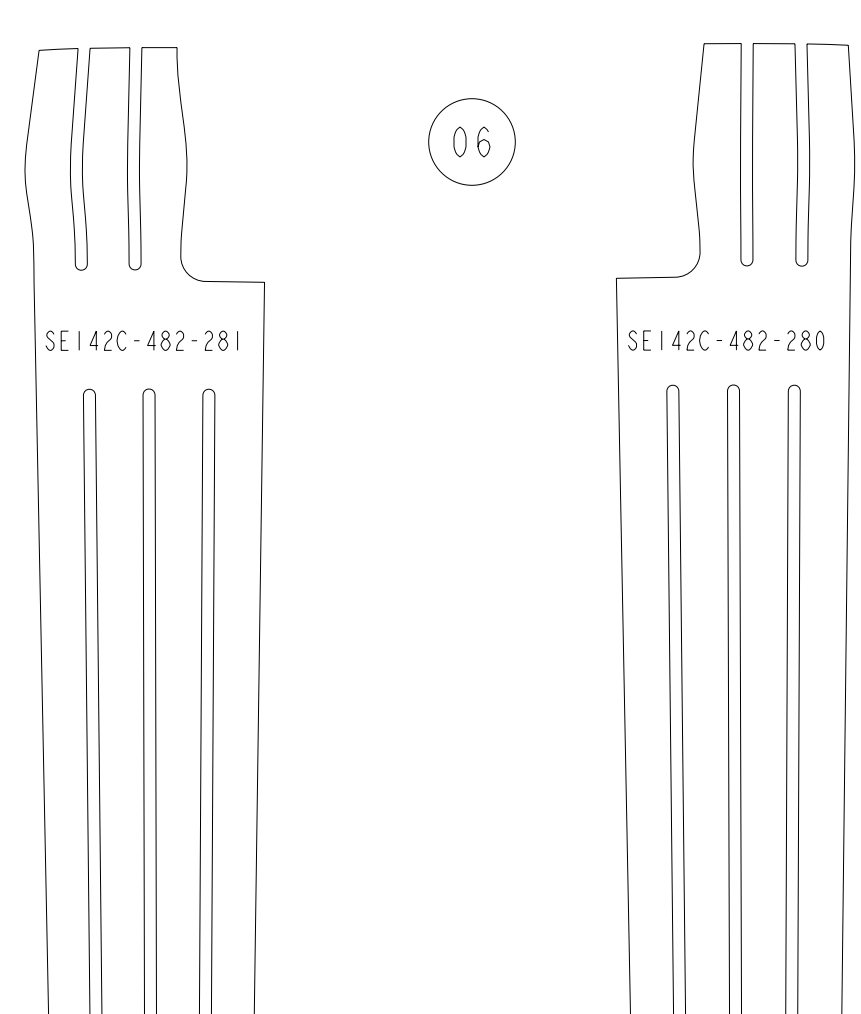

INSTANCE: SEI42C-482_FLAT_281
INSTANCE: SEI42C-482_FLAT_280

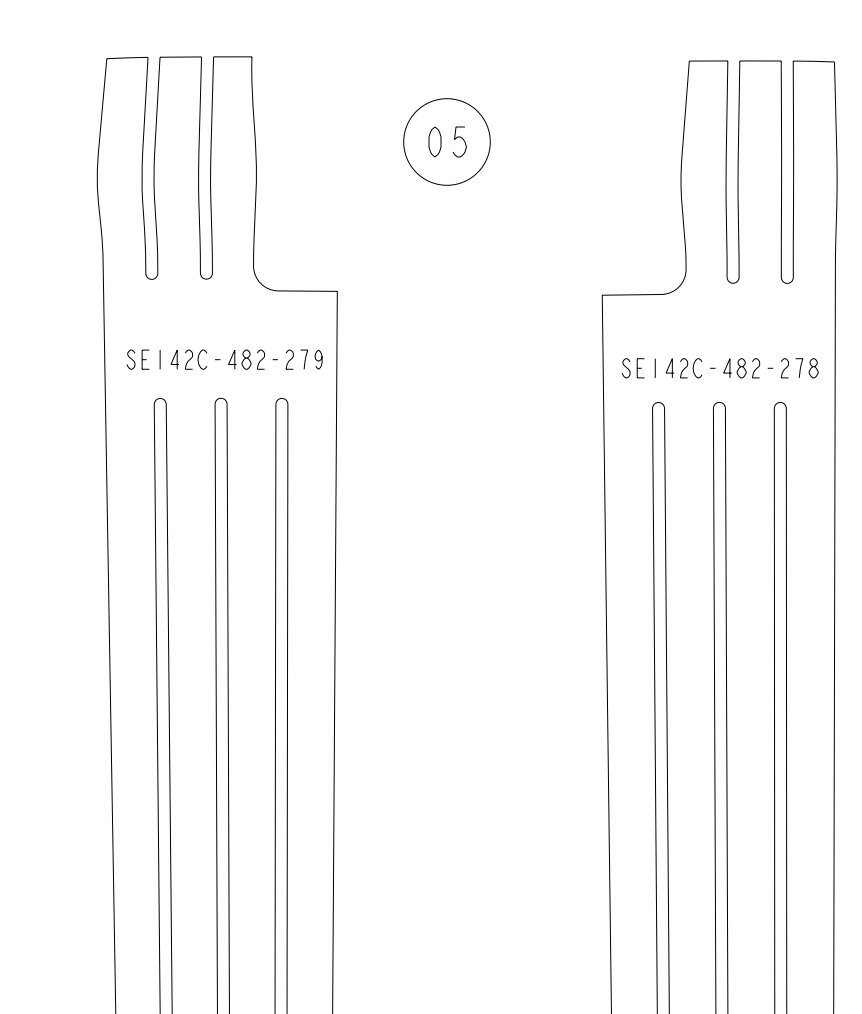

INSTANCE: SEI42C-482_FLAT_279
INSTANCE: SEI42C-482_FLAT_278

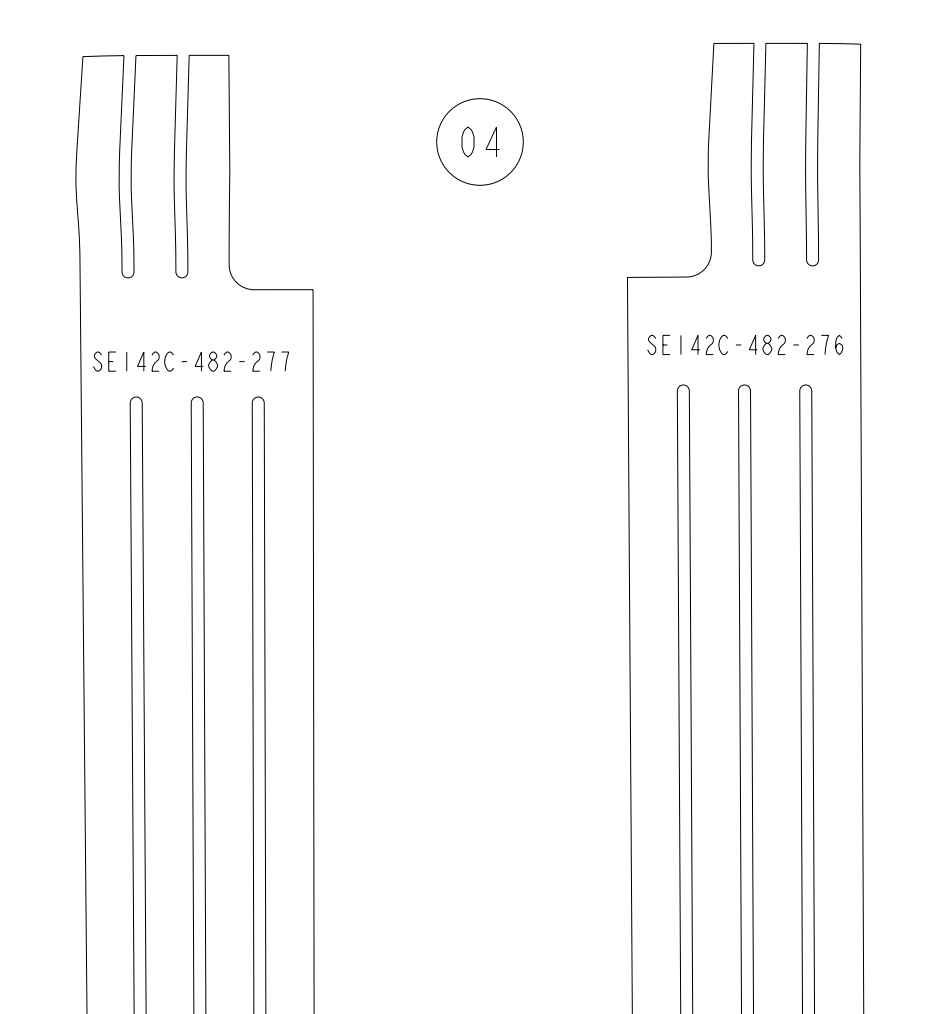

INSTANCE: SEI42C-482_FLAT_277
INSTANCE: SEI42C-482_FLAT_276

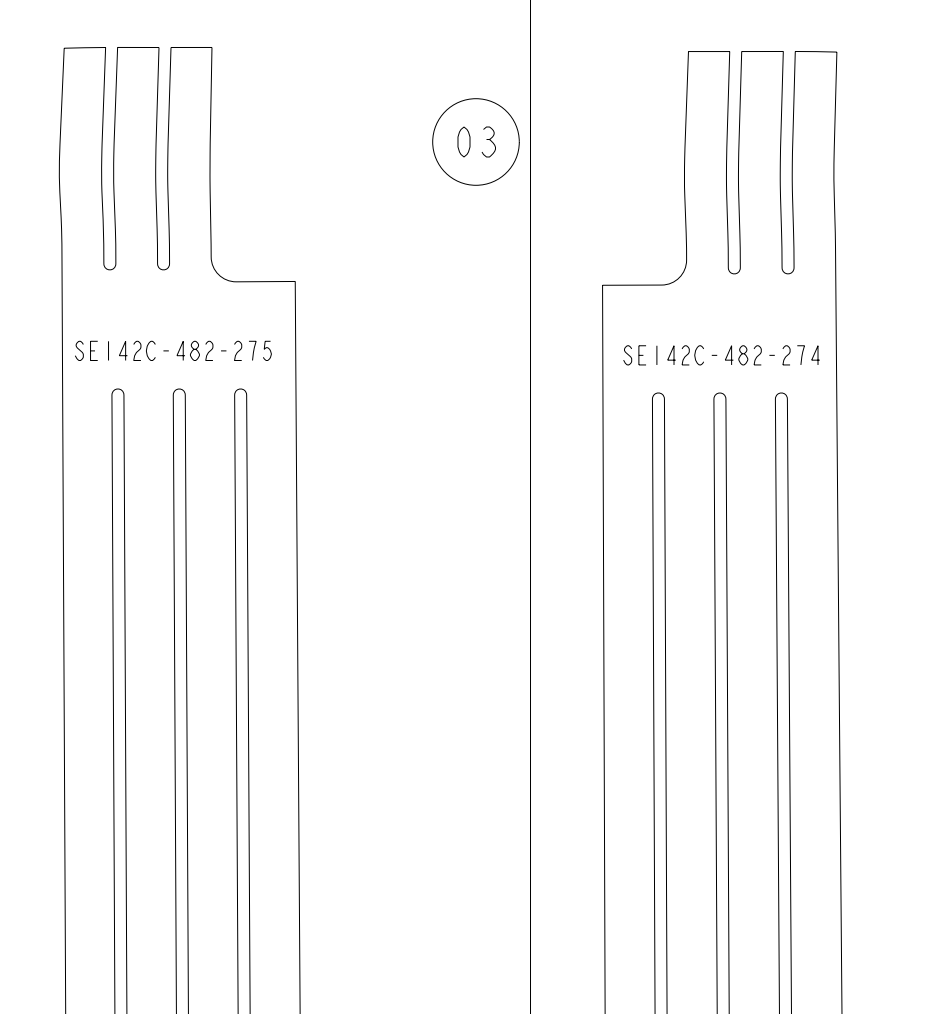

INSTANCE: SEI42C-482_FLAT_275
INSTANCE: SEI42C-482_FLAT_274

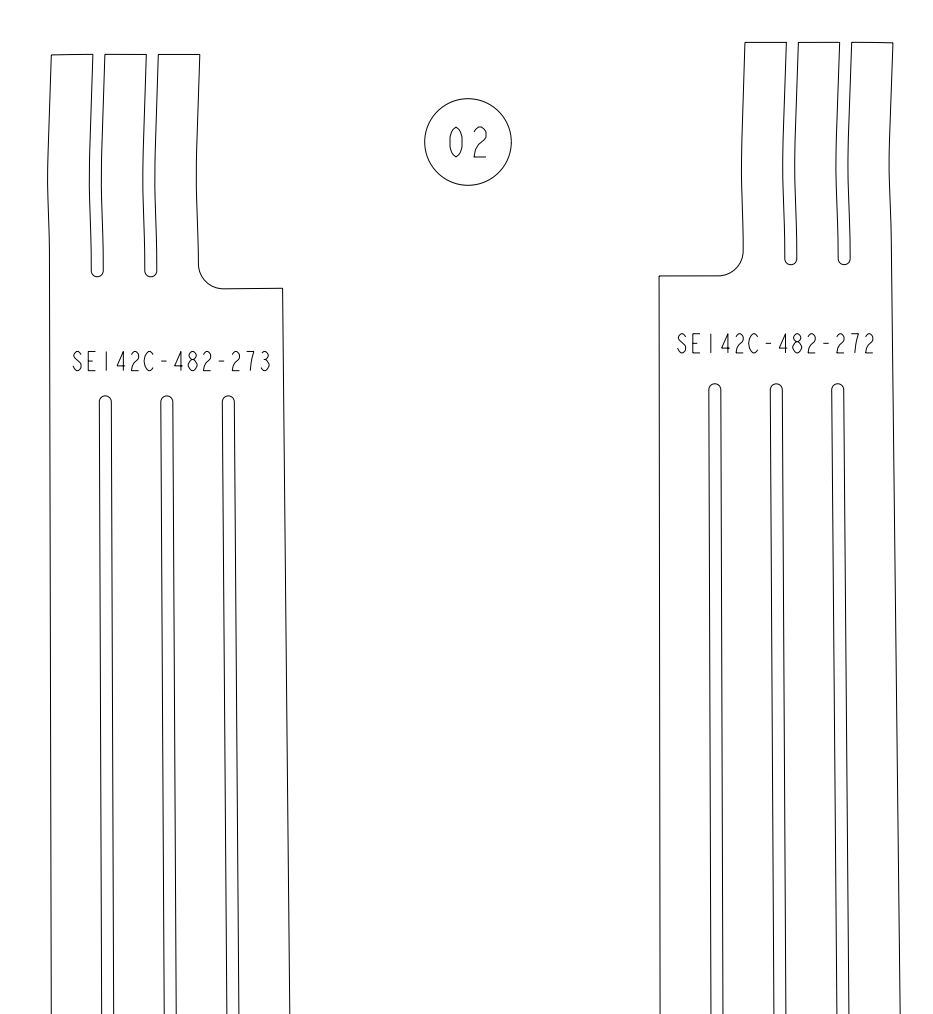

INSTANCE: SEI42C-482_FLAT_273
INSTANCE: SEI42C-482_FLAT_272

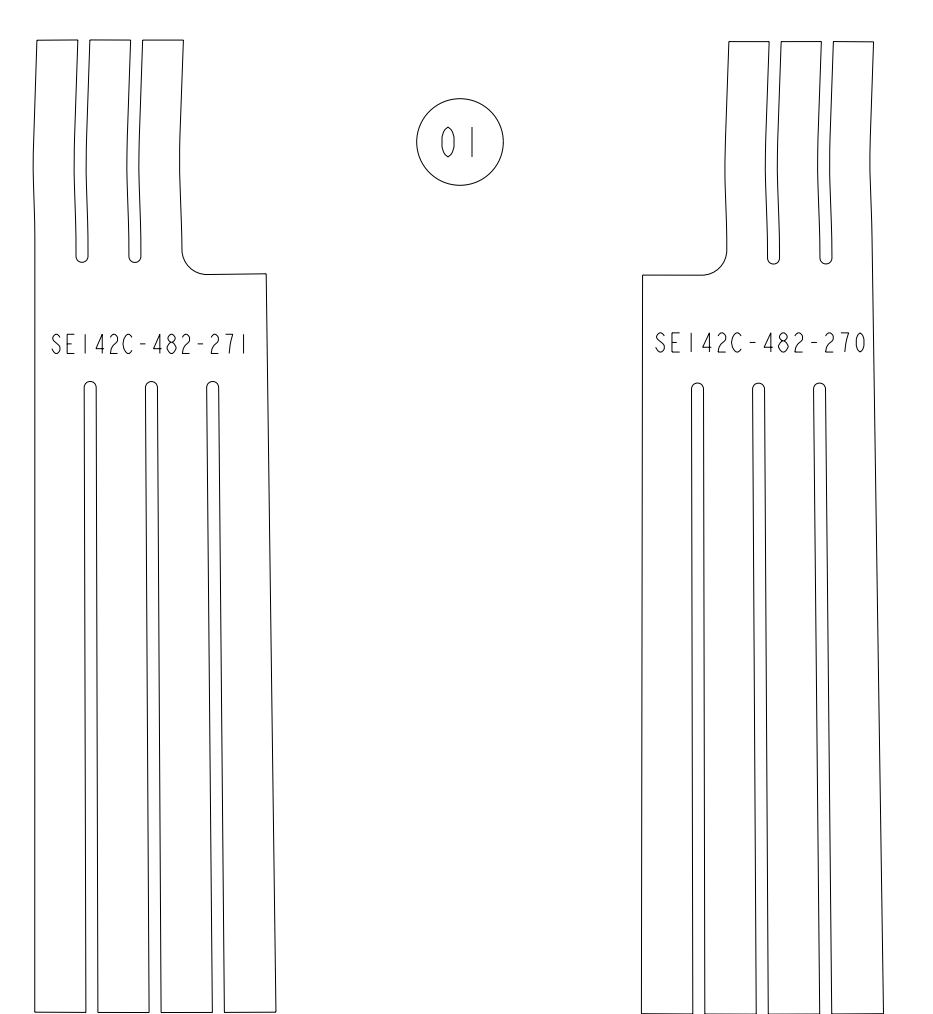

INSTANCE: SEI42C-482_FLAT_271
INSTANCE: SEI42C-482_FLAT_270

THESE PARTS TO BE NEMA GRADE GIICR MATERIAL

SCALE ALL VIEWS: 1.00

Oak Ridge National Laboratory managed for the DEPARTMENT OF ENERGY under U.S. GOVERNMENT CONTRACT DE-AC05-00OR22725 UT-BATTELLE, LLC. Oak Ridge, Tennessee PROJECT NAME:									
UT-BATTELLE NATIONAL COMPACT STELLARATOR EXPERIMENT MODULAR COIL TYPE - C SIDE -B UPPER CLADDING FLAT PATTERN LAYOUT									
VERSION NO.	PLANT	BLDG	FL	SHT	OF	TYPE	CLASS		
3	X-10	5700	3	2	5	S	U		
RELEASE LEVEL		SEI42C-482							
WIP									

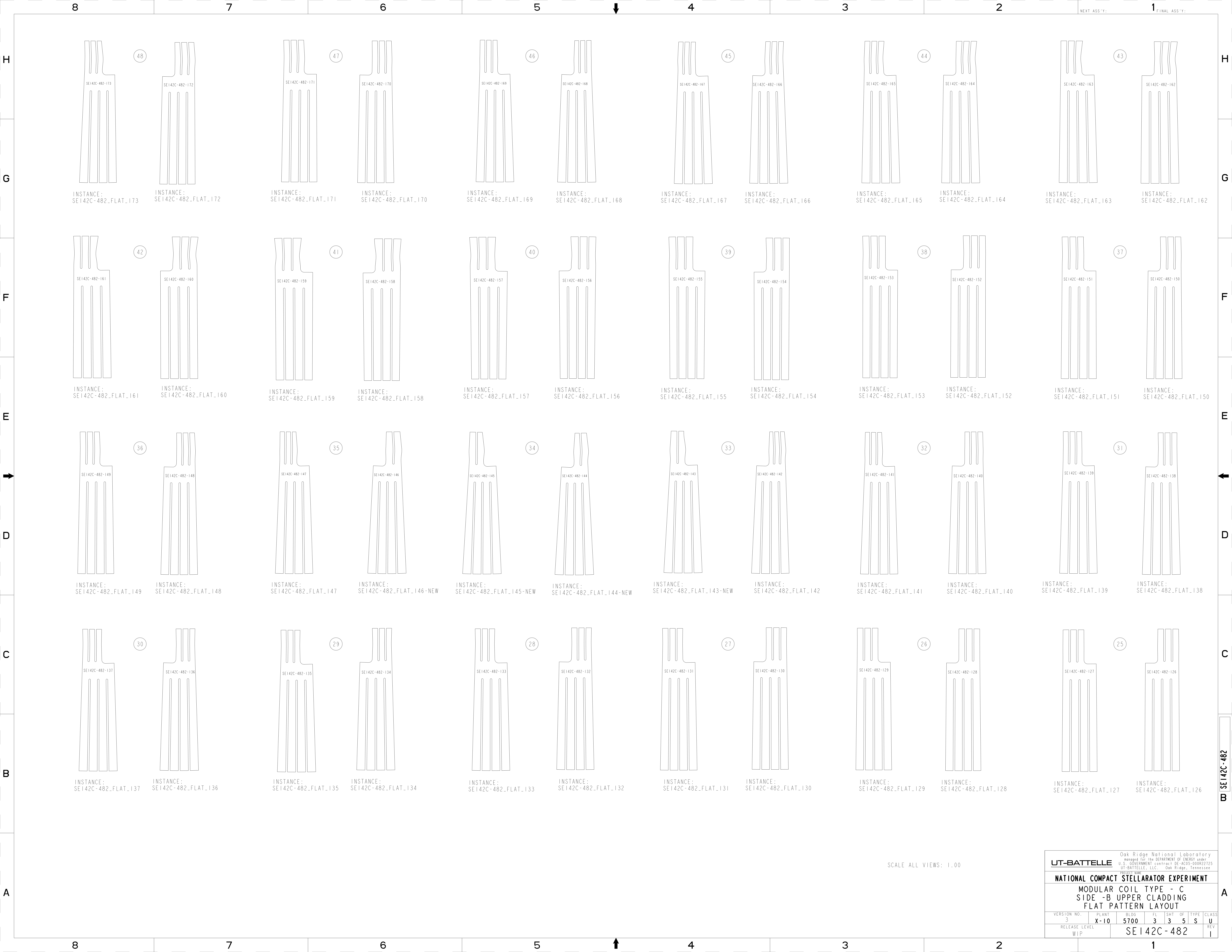

48
SEI42C-482-173
INSTANCE:
SEI42C-482_FLAT_173

48
SEI42C-482-172
INSTANCE:
SEI42C-482_FLAT_172

47
SEI42C-482-171
INSTANCE:
SEI42C-482_FLAT_171

47
SEI42C-482-170
INSTANCE:
SEI42C-482_FLAT_170

46
SEI42C-482-169
INSTANCE:
SEI42C-482_FLAT_169

46
SEI42C-482-168
INSTANCE:
SEI42C-482_FLAT_168

45
SEI42C-482-167
INSTANCE:
SEI42C-482_FLAT_167

45
SEI42C-482-166
INSTANCE:
SEI42C-482_FLAT_166

44
SEI42C-482-165
INSTANCE:
SEI42C-482_FLAT_165

44
SEI42C-482-164
INSTANCE:
SEI42C-482_FLAT_164

43
SEI42C-482-163
INSTANCE:
SEI42C-482_FLAT_163

43
SEI42C-482-162
INSTANCE:
SEI42C-482_FLAT_162

42
SEI42C-482-161
INSTANCE:
SEI42C-482_FLAT_161

42
SEI42C-482-160
INSTANCE:
SEI42C-482_FLAT_160

41
SEI42C-482-159
INSTANCE:
SEI42C-482_FLAT_159

41
SEI42C-482-158
INSTANCE:
SEI42C-482_FLAT_158

40
SEI42C-482-157
INSTANCE:
SEI42C-482_FLAT_157

40
SEI42C-482-156
INSTANCE:
SEI42C-482_FLAT_156

39
SEI42C-482-155
INSTANCE:
SEI42C-482_FLAT_155

39
SEI42C-482-154
INSTANCE:
SEI42C-482_FLAT_154

38
SEI42C-482-153
INSTANCE:
SEI42C-482_FLAT_153

38
SEI42C-482-152
INSTANCE:
SEI42C-482_FLAT_152

37
SEI42C-482-151
INSTANCE:
SEI42C-482_FLAT_151

37
SEI42C-482-150
INSTANCE:
SEI42C-482_FLAT_150

36
SEI42C-482-149
INSTANCE:
SEI42C-482_FLAT_149

36
SEI42C-482-148
INSTANCE:
SEI42C-482_FLAT_148

35
SEI42C-482-147
INSTANCE:
SEI42C-482_FLAT_147

35
SEI42C-482-146-NEW
INSTANCE:
SEI42C-482_FLAT_146-NEW

34
SEI42C-482-145
INSTANCE:
SEI42C-482_FLAT_145-NEW

34
SEI42C-482-144
INSTANCE:
SEI42C-482_FLAT_144-NEW

33
SEI42C-482-143
INSTANCE:
SEI42C-482_FLAT_143-NEW

33
SEI42C-482-142
INSTANCE:
SEI42C-482_FLAT_142

32
SEI42C-482-141
INSTANCE:
SEI42C-482_FLAT_141

32
SEI42C-482-140
INSTANCE:
SEI42C-482_FLAT_140

31
SEI42C-482-139
INSTANCE:
SEI42C-482_FLAT_139

31
SEI42C-482-138
INSTANCE:
SEI42C-482_FLAT_138

30
SEI42C-482-137
INSTANCE:
SEI42C-482_FLAT_137

30
SEI42C-482-136
INSTANCE:
SEI42C-482_FLAT_136

29
SEI42C-482-135
INSTANCE:
SEI42C-482_FLAT_135

29
SEI42C-482-134
INSTANCE:
SEI42C-482_FLAT_134

28
SEI42C-482-133
INSTANCE:
SEI42C-482_FLAT_133

28
SEI42C-482-132
INSTANCE:
SEI42C-482_FLAT_132

27
SEI42C-482-131
INSTANCE:
SEI42C-482_FLAT_131

27
SEI42C-482-130
INSTANCE:
SEI42C-482_FLAT_130

26
SEI42C-482-129
INSTANCE:
SEI42C-482_FLAT_129

26
SEI42C-482-128
INSTANCE:
SEI42C-482_FLAT_128

25
SEI42C-482-127
INSTANCE:
SEI42C-482_FLAT_127

25
SEI42C-482-126
INSTANCE:
SEI42C-482_FLAT_126

SCALE ALL VIEWS: 1.00

Oak Ridge National Laboratory
managed for the DEPARTMENT OF ENERGY under
U.S. GOVERNMENT CONTRACT DE-AC05-00OR22725
UT-BATTELLE, LLC, Oak Ridge, Tennessee
PROJECT NAME

UT-BATTELLE

NATIONAL COMPACT STELLARATOR EXPERIMENT

MODULAR COIL TYPE - C
SIDE -B UPPER CLADDING
FLAT PATTERN LAYOUT

VERSION NO. 3	PLANT X-10	BLDG 5700	FL 3	SHT 5	OF 5	TYPE S	CLASS U
RELEASE LEVEL WIP		SEI42C-482				REV 1	

SEI42C-482

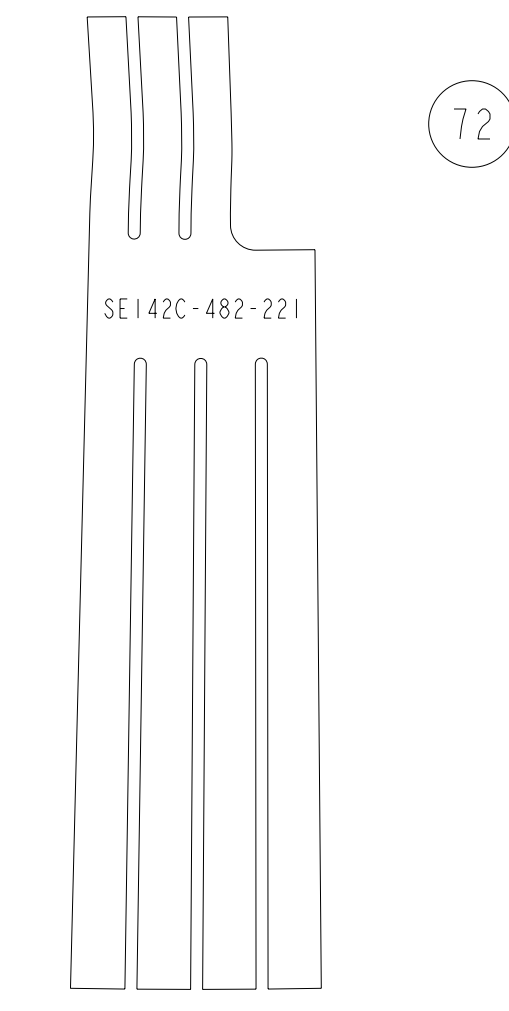
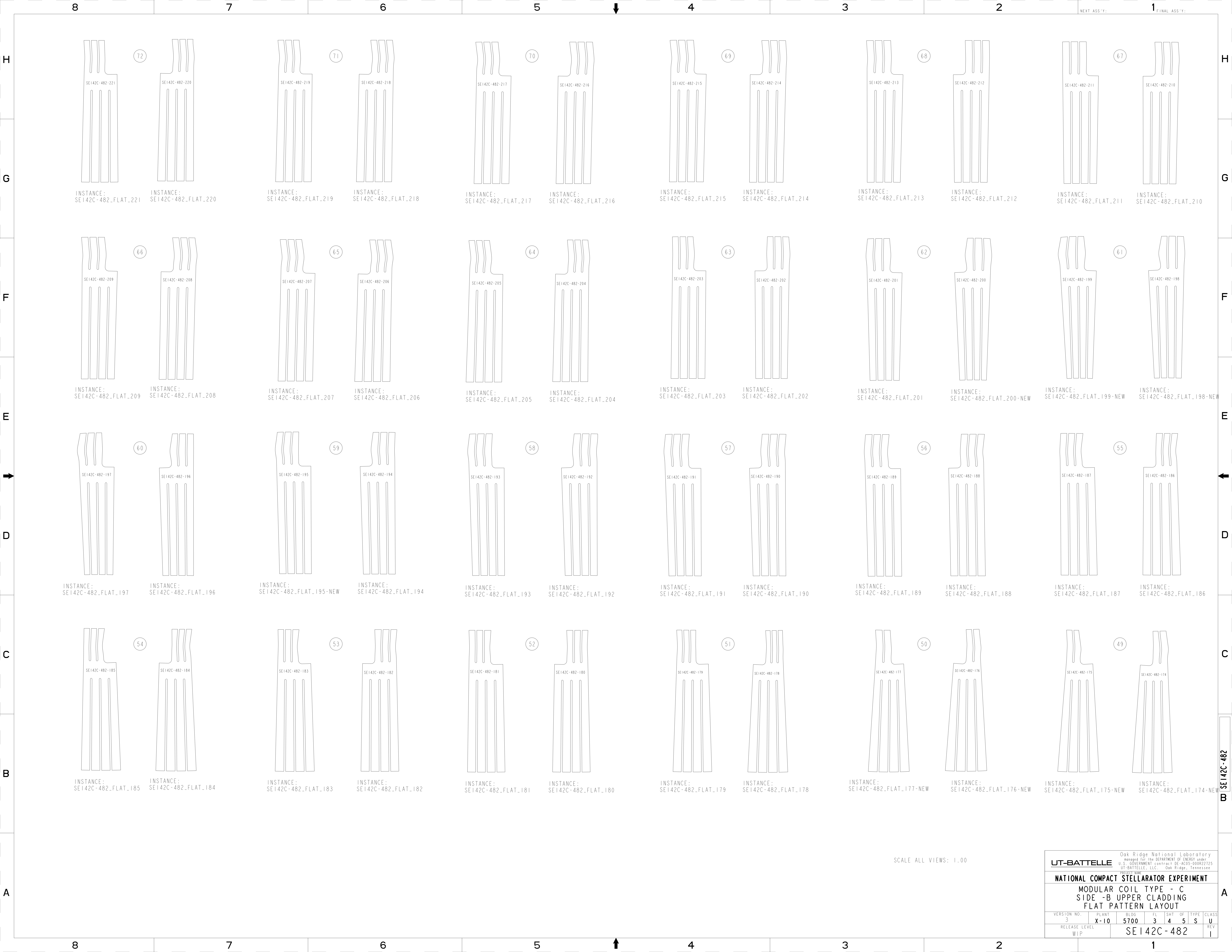

INSTANCE: SEI42C-482_FLAT_221
INSTANCE: SEI42C-482_FLAT_220

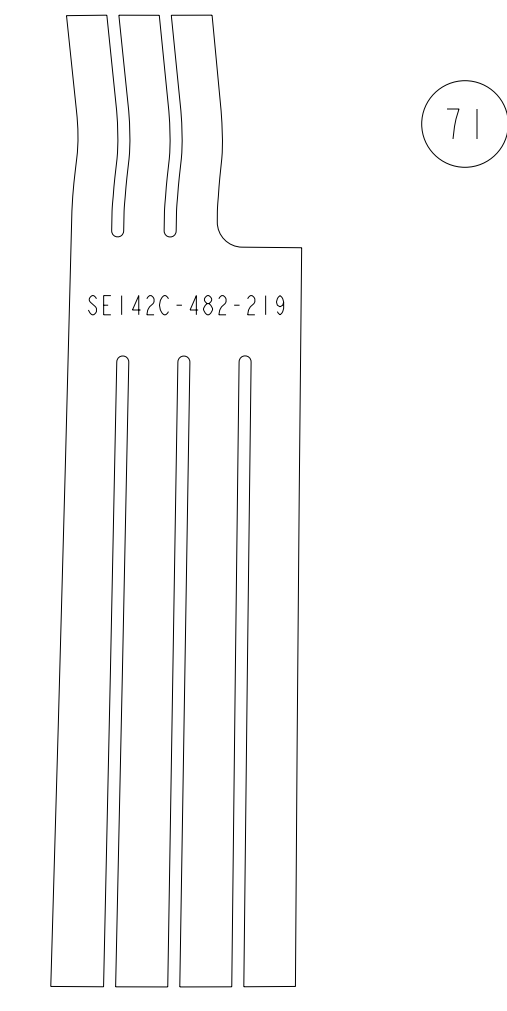

INSTANCE: SEI42C-482_FLAT_219
INSTANCE: SEI42C-482_FLAT_218

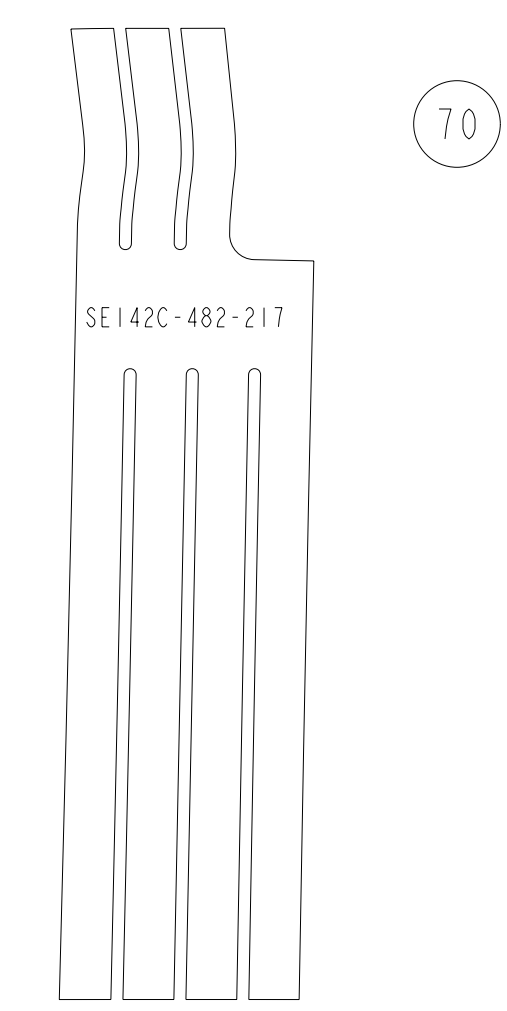

INSTANCE: SEI42C-482_FLAT_217
INSTANCE: SEI42C-482_FLAT_216

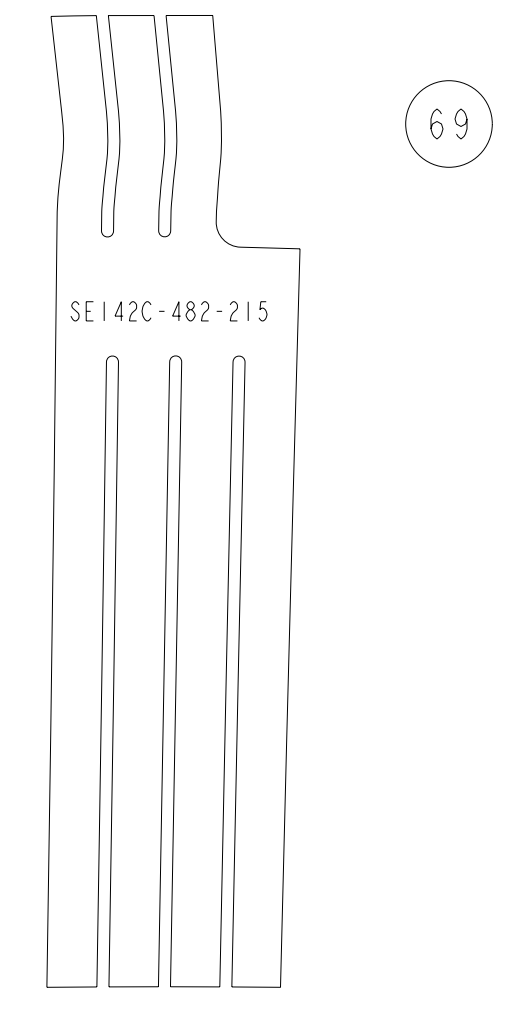

INSTANCE: SEI42C-482_FLAT_215
INSTANCE: SEI42C-482_FLAT_214

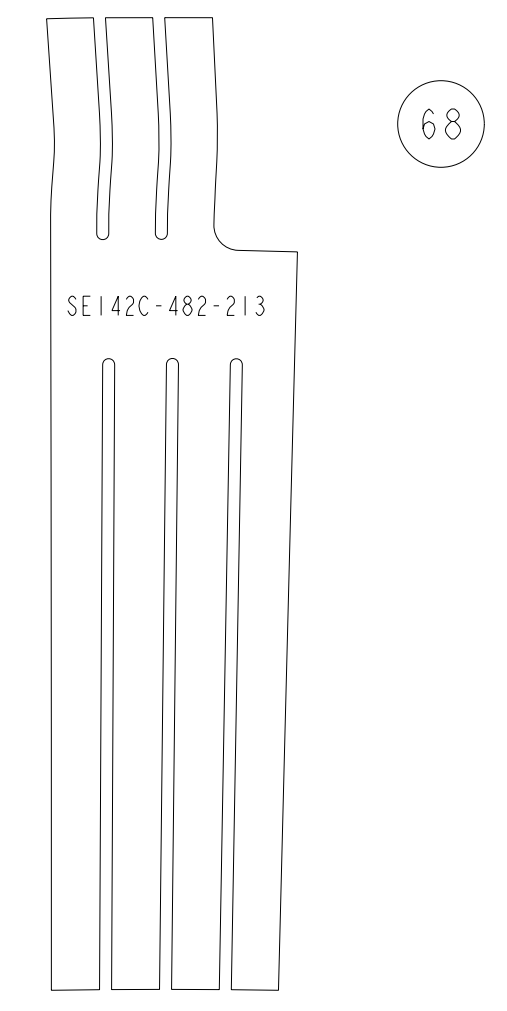

INSTANCE: SEI42C-482_FLAT_213
INSTANCE: SEI42C-482_FLAT_212

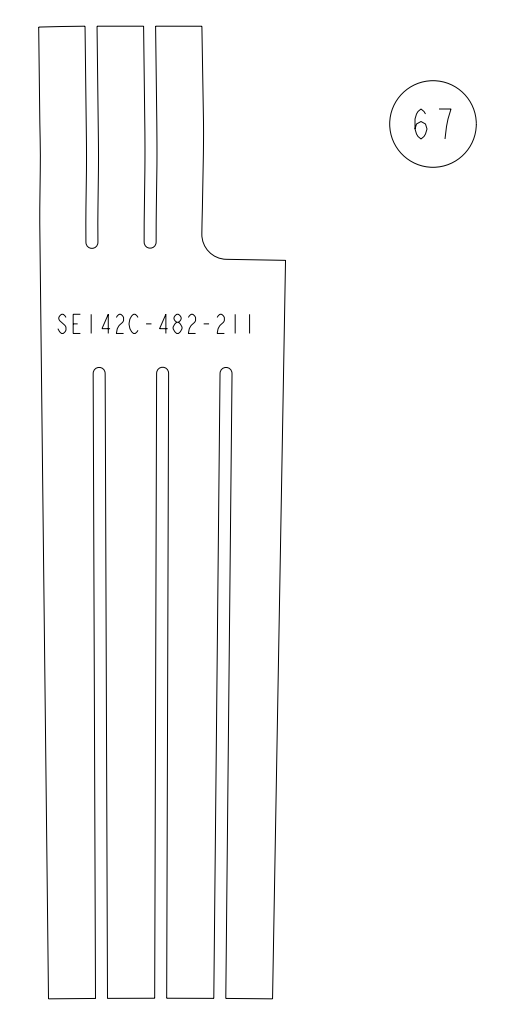

INSTANCE: SEI42C-482_FLAT_211
INSTANCE: SEI42C-482_FLAT_210

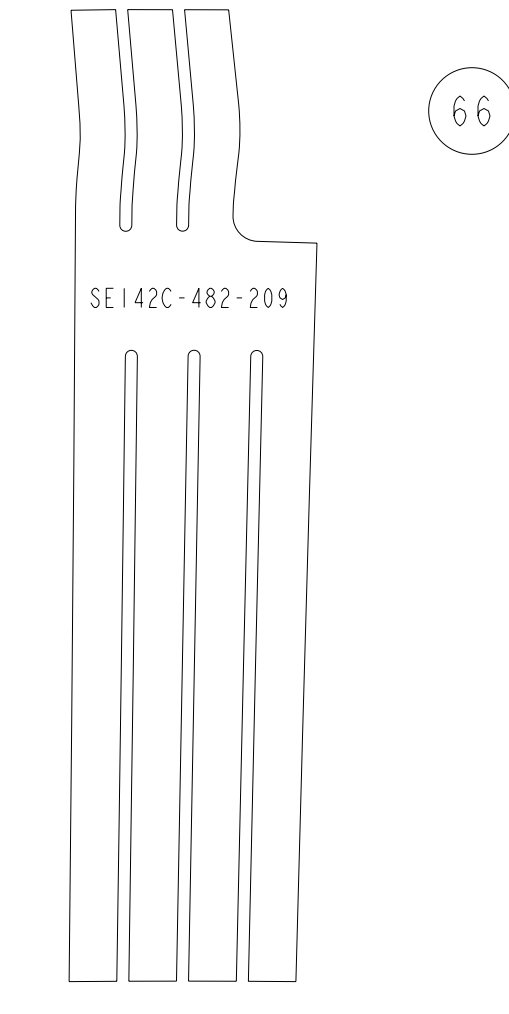

INSTANCE: SEI42C-482_FLAT_209
INSTANCE: SEI42C-482_FLAT_208

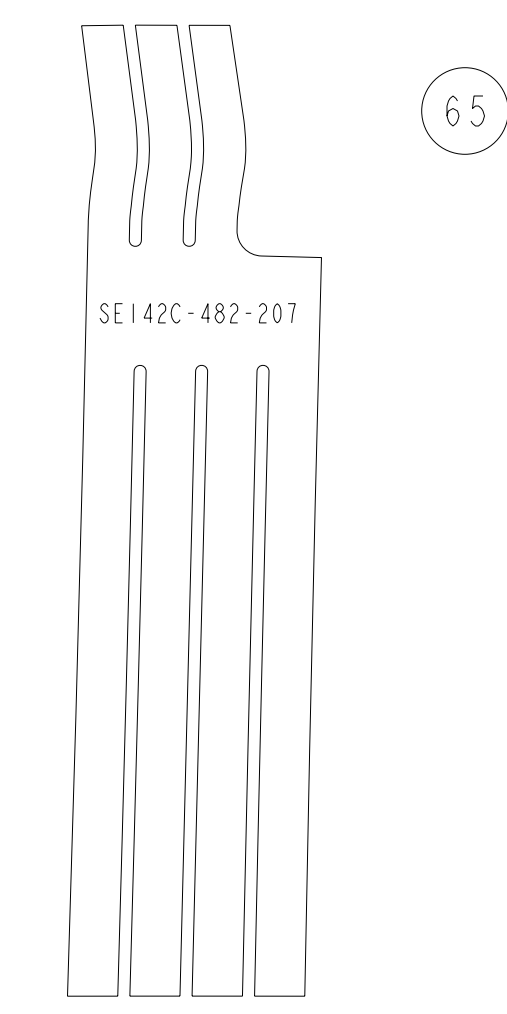

INSTANCE: SEI42C-482_FLAT_207
INSTANCE: SEI42C-482_FLAT_206

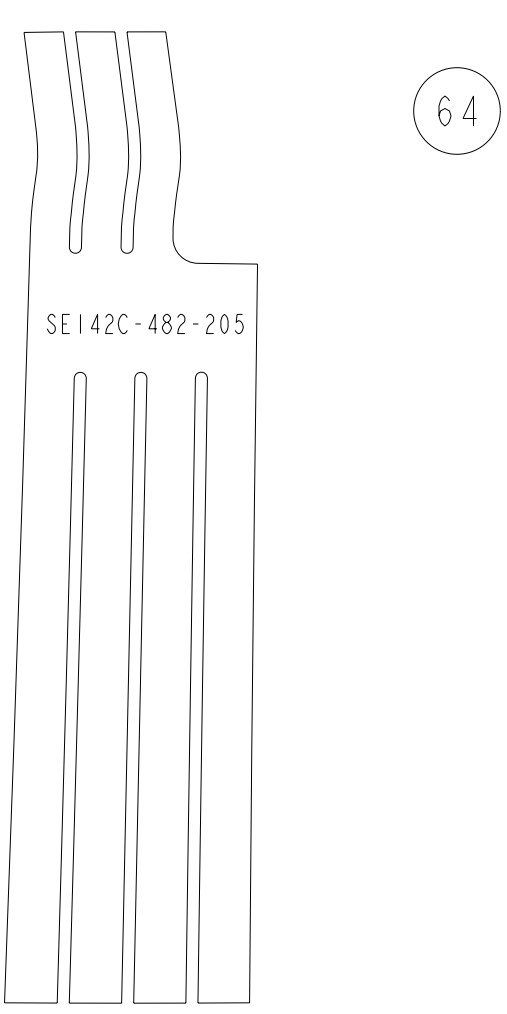

INSTANCE: SEI42C-482_FLAT_205
INSTANCE: SEI42C-482_FLAT_204

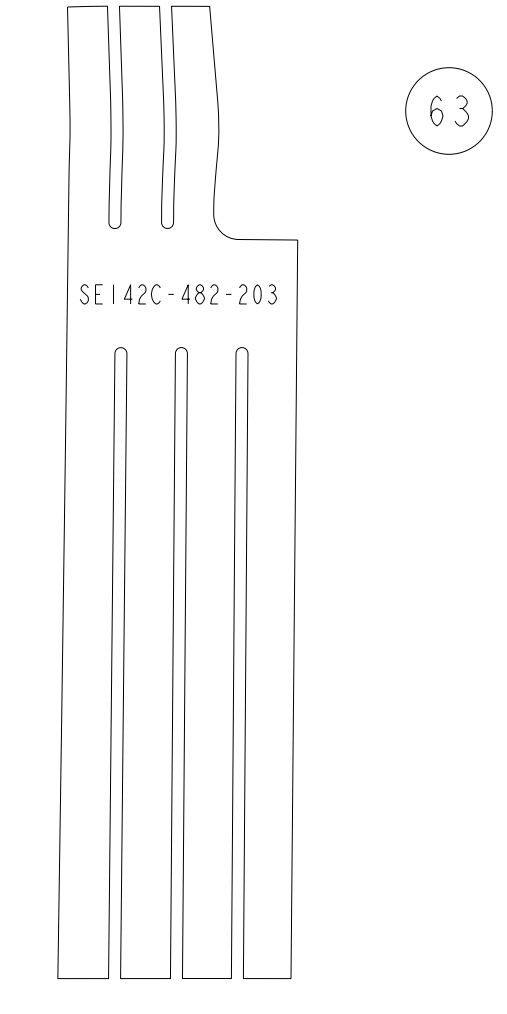

INSTANCE: SEI42C-482_FLAT_203
INSTANCE: SEI42C-482_FLAT_202

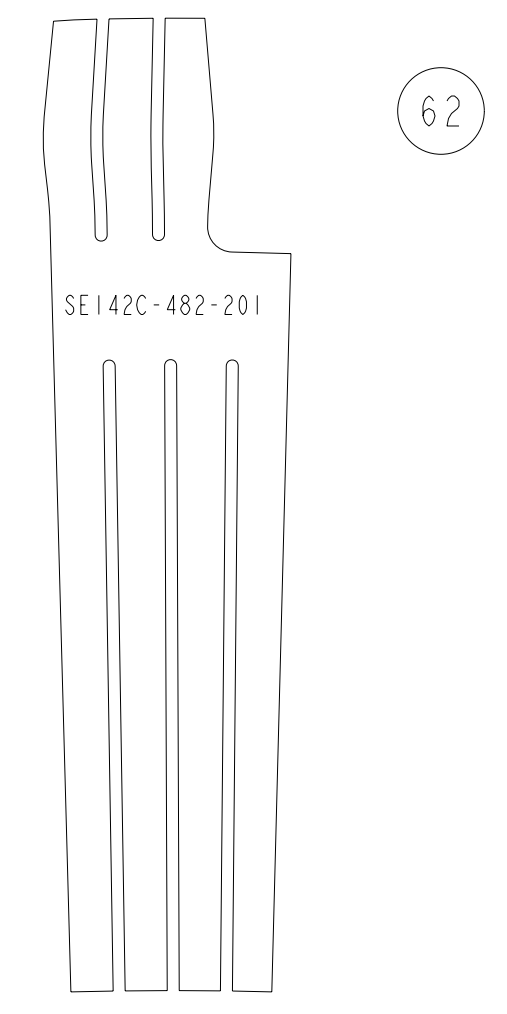

INSTANCE: SEI42C-482_FLAT_201
INSTANCE: SEI42C-482_FLAT_200-NEW

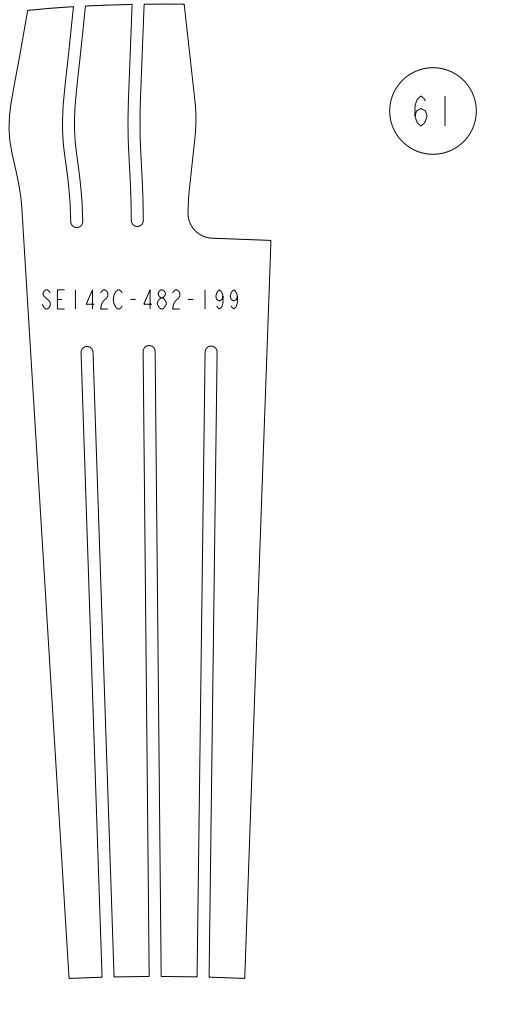

INSTANCE: SEI42C-482_FLAT_199-NEW
INSTANCE: SEI42C-482_FLAT_198-NEW

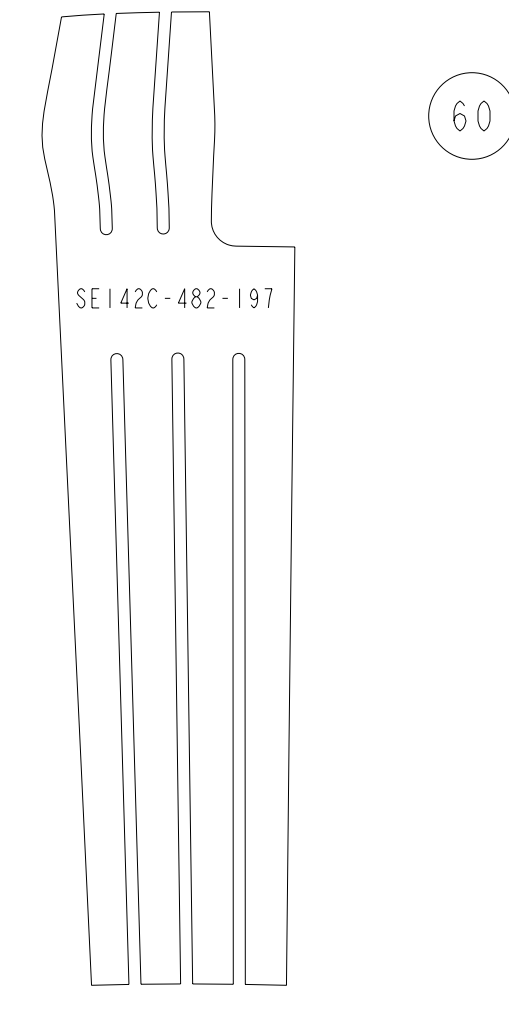

INSTANCE: SEI42C-482_FLAT_197
INSTANCE: SEI42C-482_FLAT_196

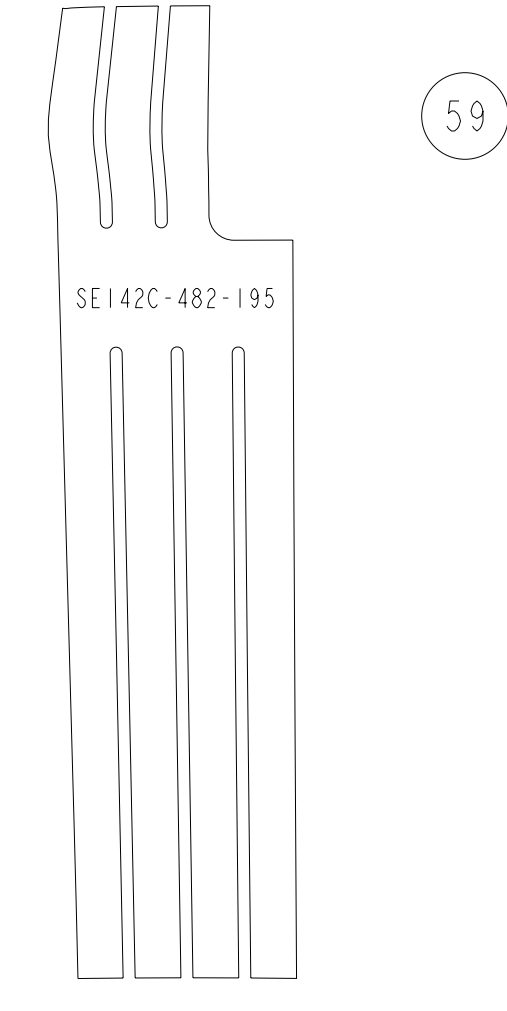

INSTANCE: SEI42C-482_FLAT_195-NEW
INSTANCE: SEI42C-482_FLAT_194

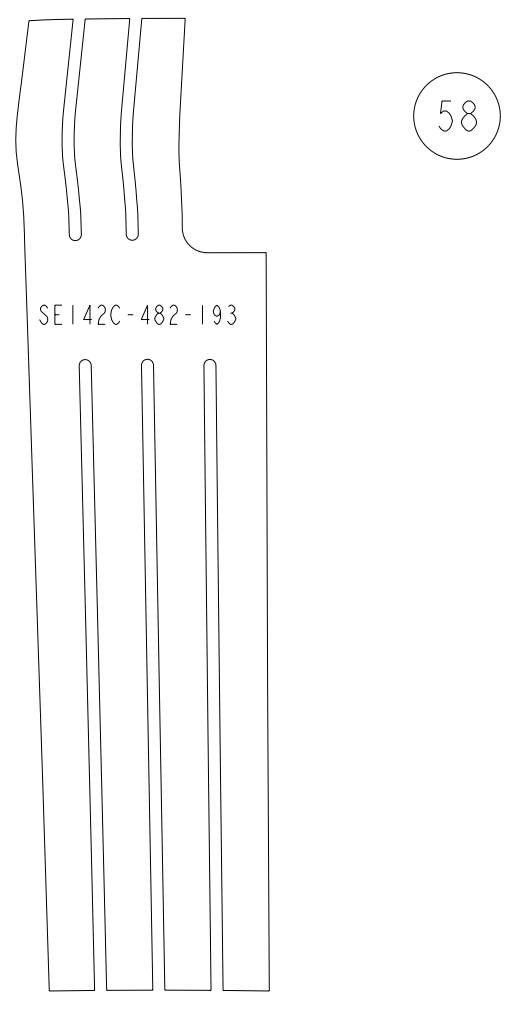

INSTANCE: SEI42C-482_FLAT_193
INSTANCE: SEI42C-482_FLAT_192

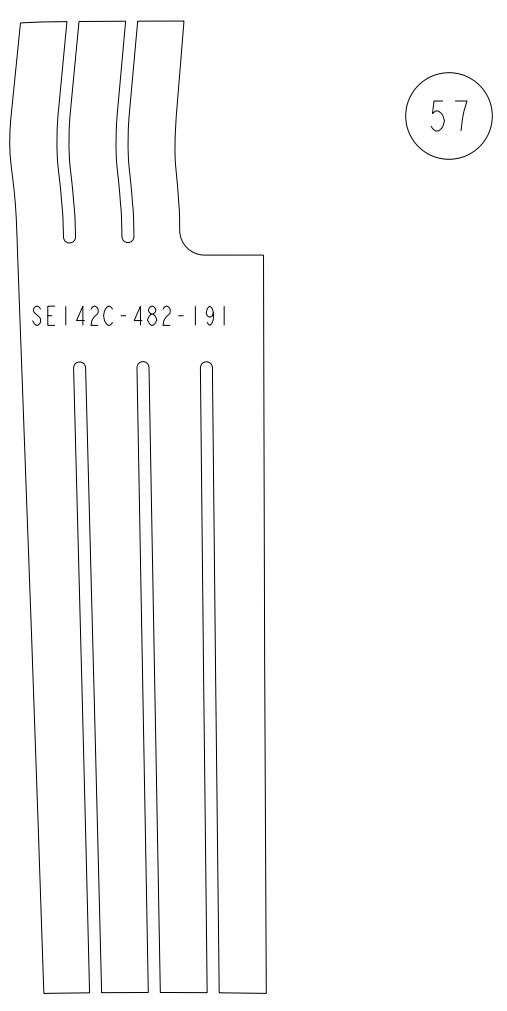

INSTANCE: SEI42C-482_FLAT_191
INSTANCE: SEI42C-482_FLAT_190

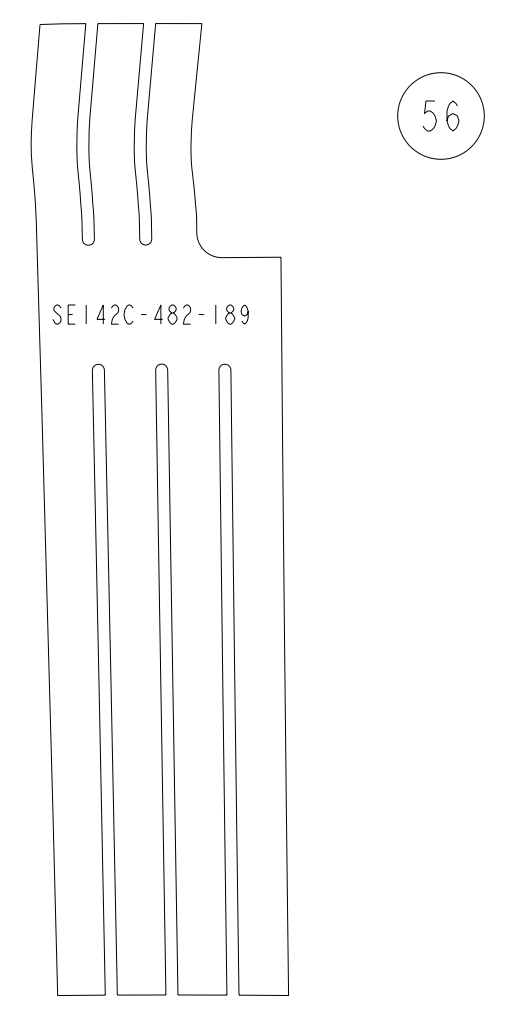

INSTANCE: SEI42C-482_FLAT_189
INSTANCE: SEI42C-482_FLAT_188

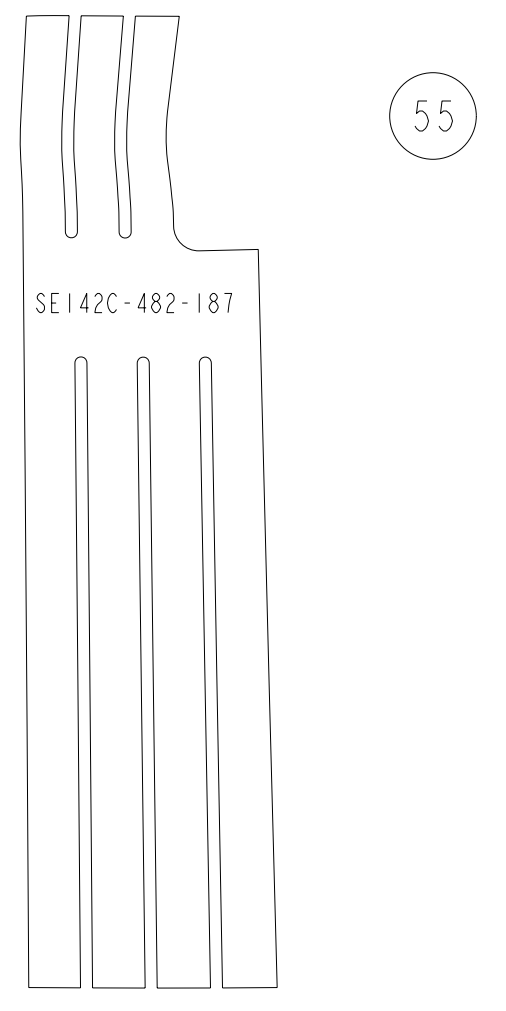

INSTANCE: SEI42C-482_FLAT_187
INSTANCE: SEI42C-482_FLAT_186

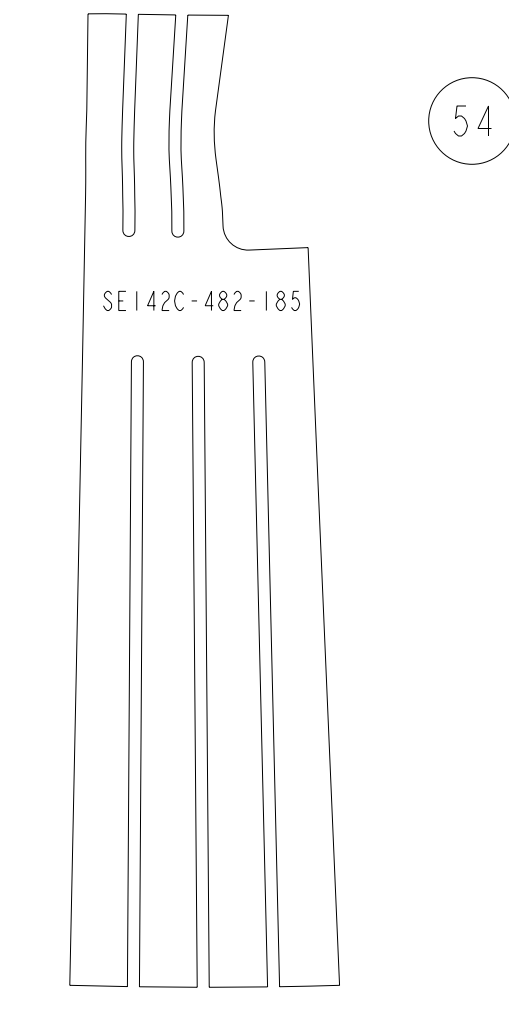

INSTANCE: SEI42C-482_FLAT_185
INSTANCE: SEI42C-482_FLAT_184

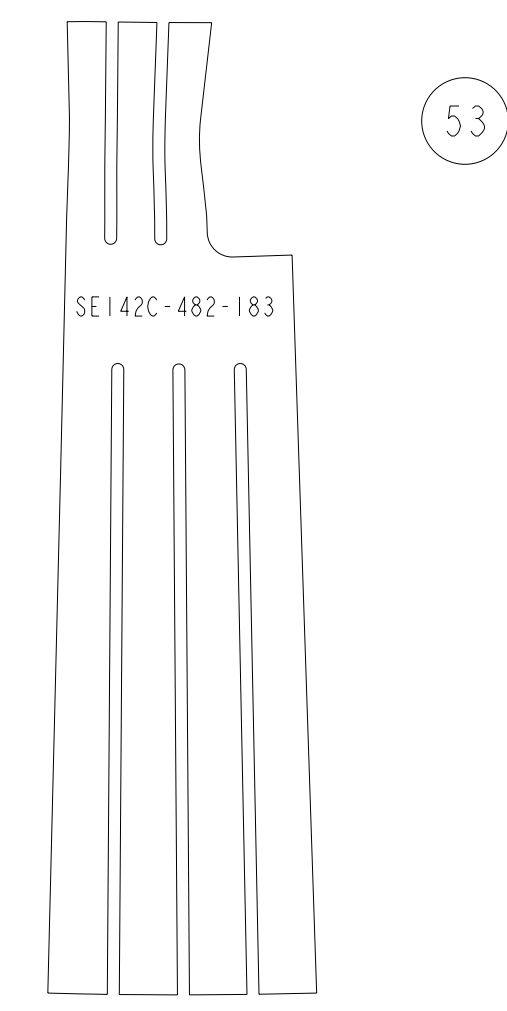

INSTANCE: SEI42C-482_FLAT_183
INSTANCE: SEI42C-482_FLAT_182

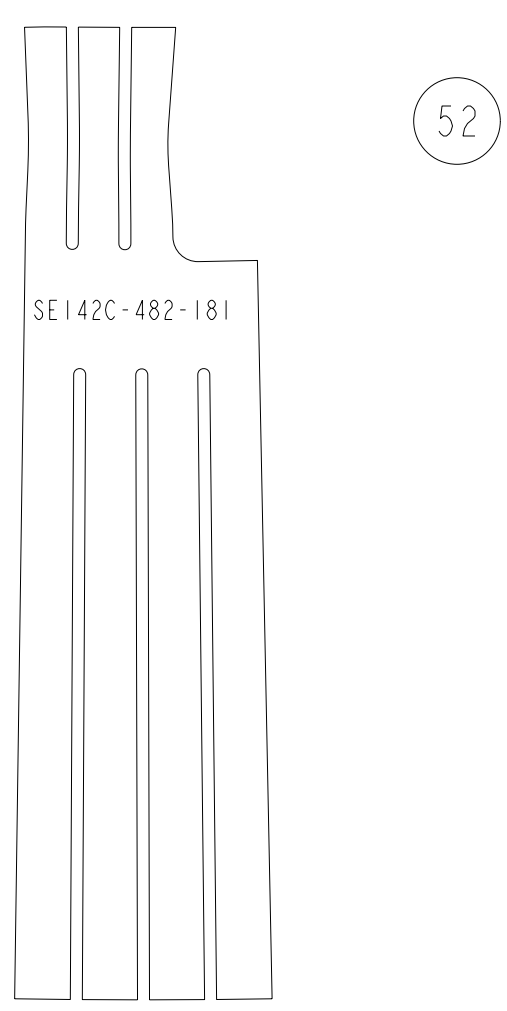

INSTANCE: SEI42C-482_FLAT_181
INSTANCE: SEI42C-482_FLAT_180

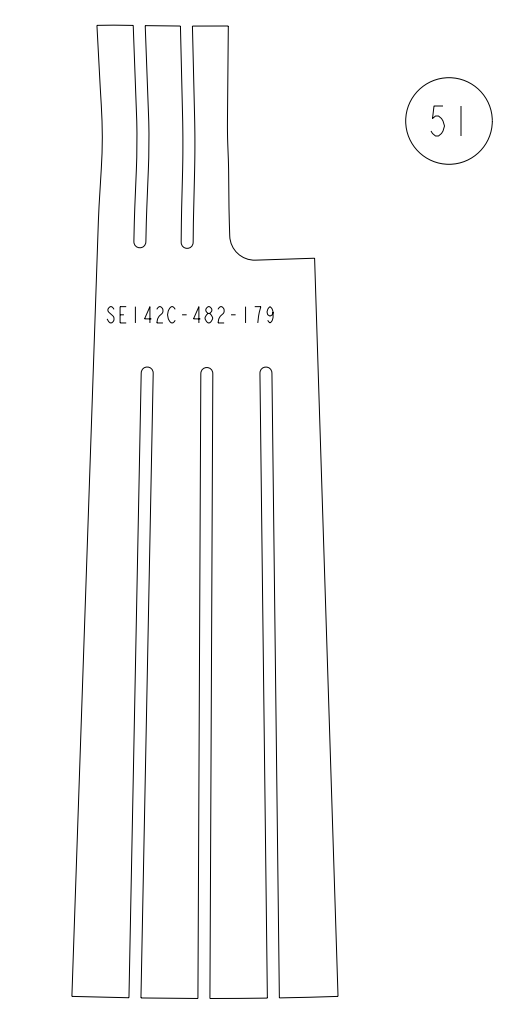

INSTANCE: SEI42C-482_FLAT_179
INSTANCE: SEI42C-482_FLAT_178

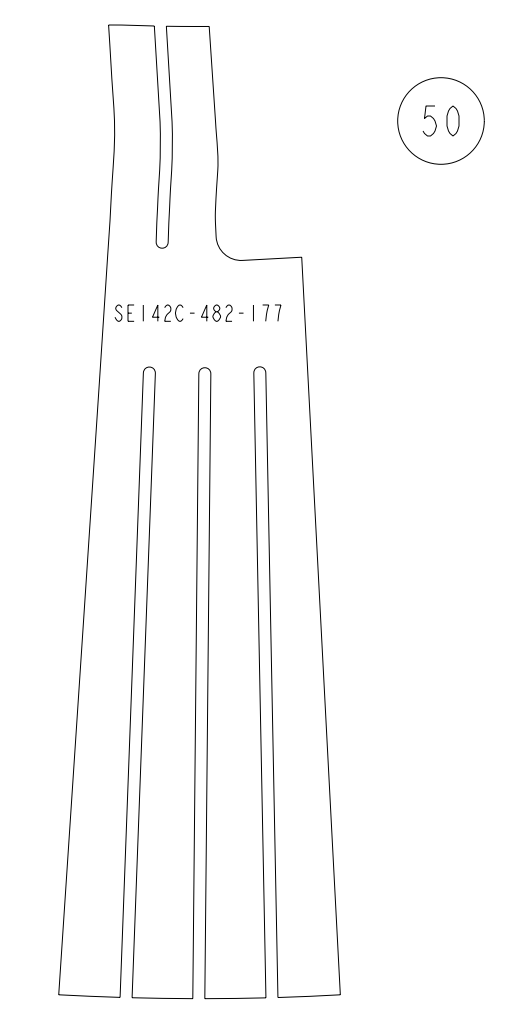

INSTANCE: SEI42C-482_FLAT_177-NEW
INSTANCE: SEI42C-482_FLAT_176-NEW

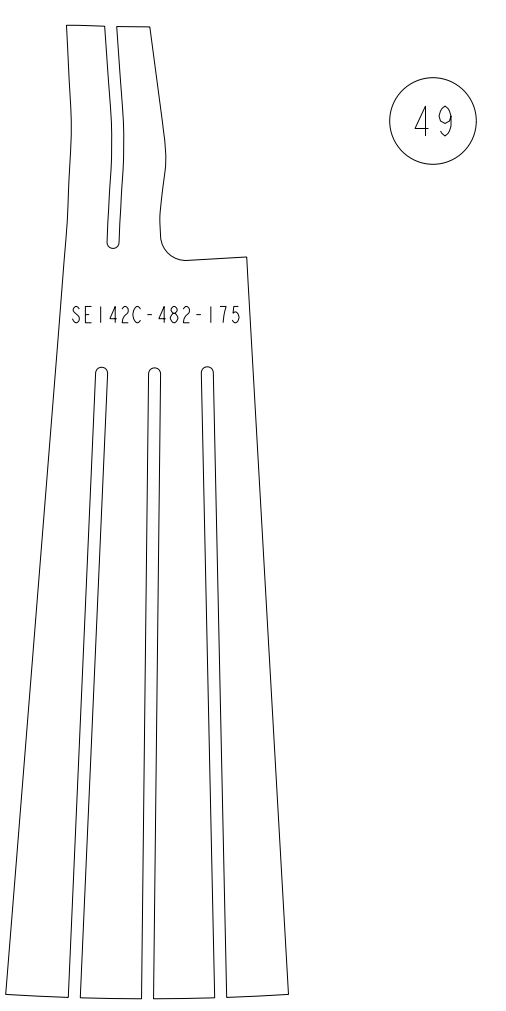

INSTANCE: SEI42C-482_FLAT_175-NEW
INSTANCE: SEI42C-482_FLAT_174-NEW

SCALE ALL VIEWS: 1:00

Oak Ridge National Laboratory
managed for the DEPARTMENT OF ENERGY under
U.S. GOVERNMENT CONTRACT DE-AC05-00OR22725
UT-BATTELLE, LLC, Oak Ridge, Tennessee
PROJECT NAME
NATIONAL COMPACT STELLARATOR EXPERIMENT
MODULAR COIL TYPE - C
SIDE -B UPPER CLADDING
FLAT PATTERN LAYOUT

VERSION NO.	PLANT	BLDG	FL	SHT	OF	TYPE	CLASS
3	X-10	5700	3	4	5	S	U
RELEASE LEVEL		SEI42C-482				REV	
WIP						I	

SEI42C-482

1

THESE PARTS TO BE NEMA GRADE GIICR MATERIAL

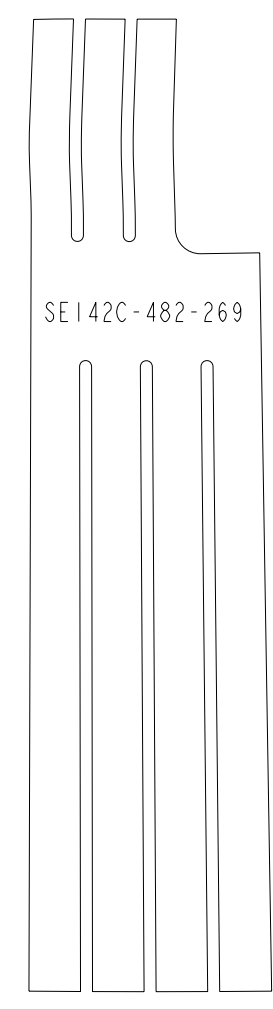

96

INSTANCE:
SEI42C-482_FLAT_269

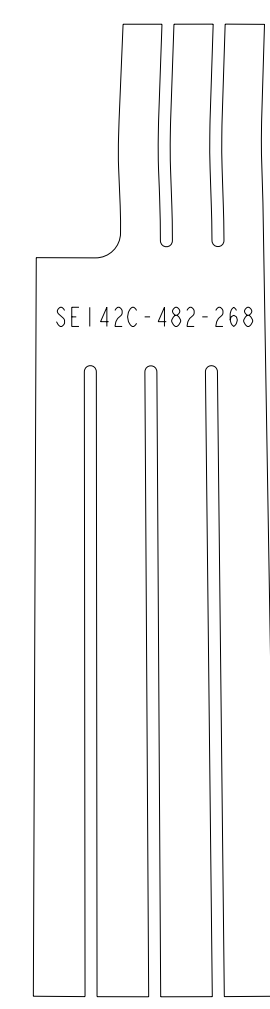

INSTANCE:
SEI42C-482_FLAT_268

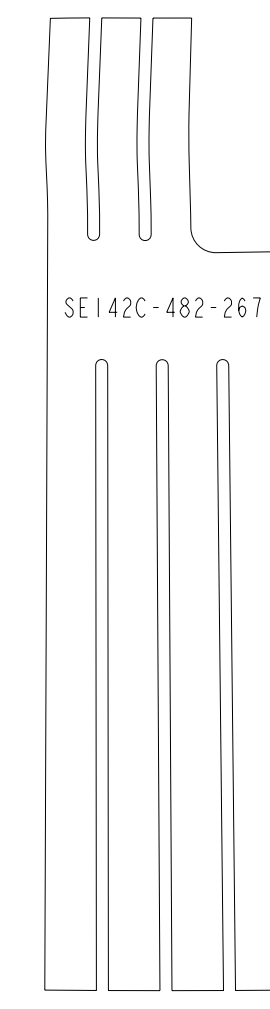

INSTANCE:
SEI42C-482_FLAT_267

95

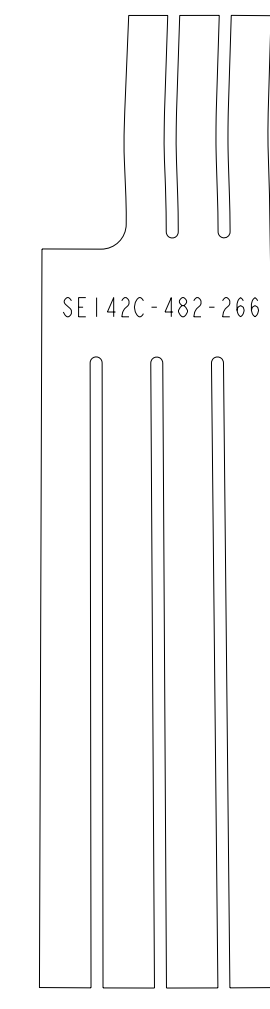

INSTANCE:
SEI42C-482_FLAT_266

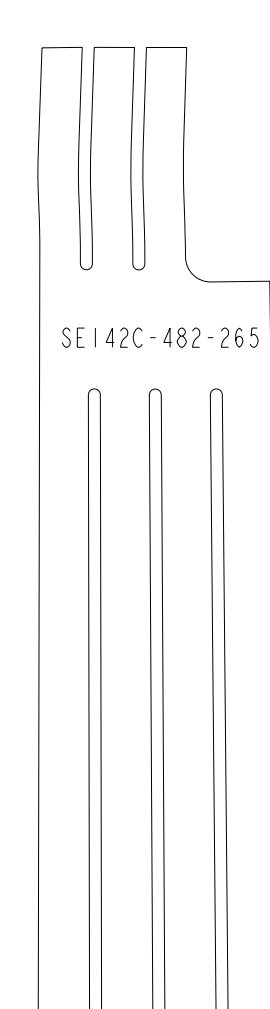

INSTANCE:
SEI42C-482_FLAT_265

94

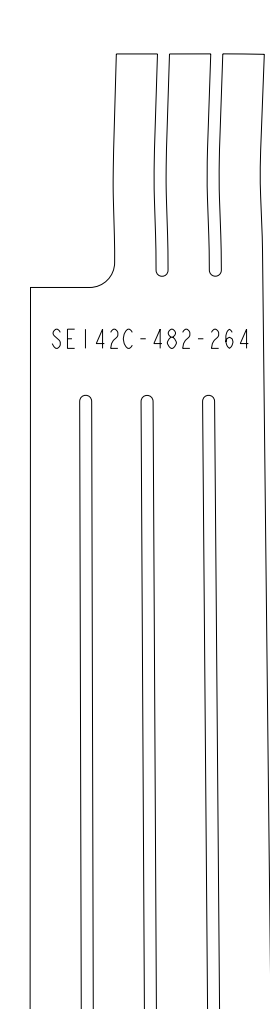

INSTANCE:
SEI42C-482_FLAT_264

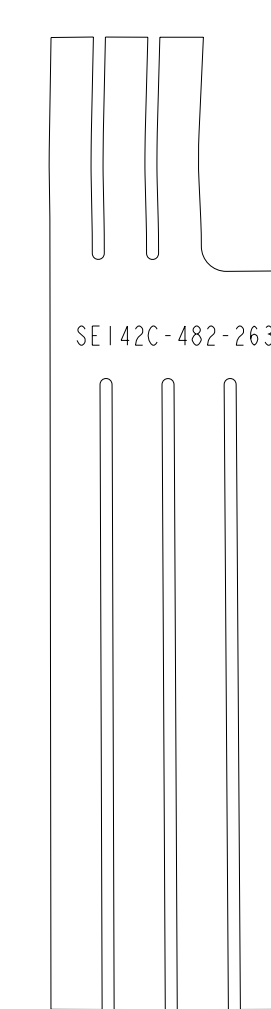

INSTANCE:
SEI42C-482_FLAT_263

93

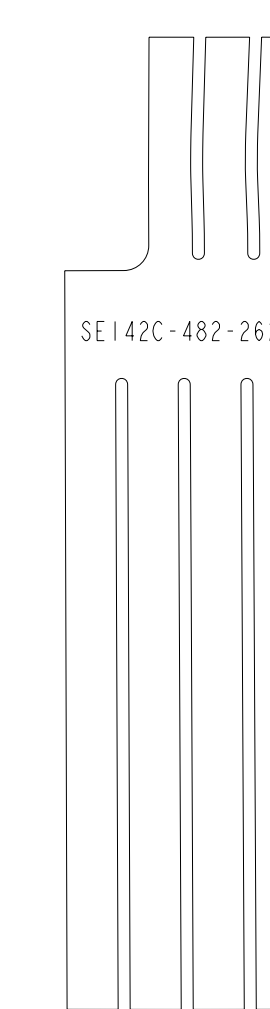

INSTANCE:
SEI42C-482_FLAT_262

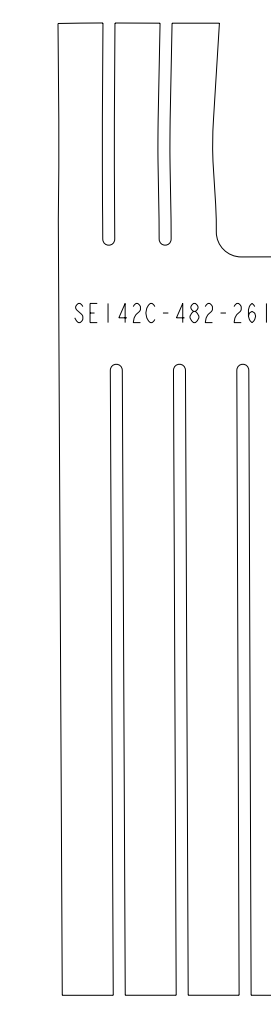

INSTANCE:
SEI42C-482_FLAT_261

92

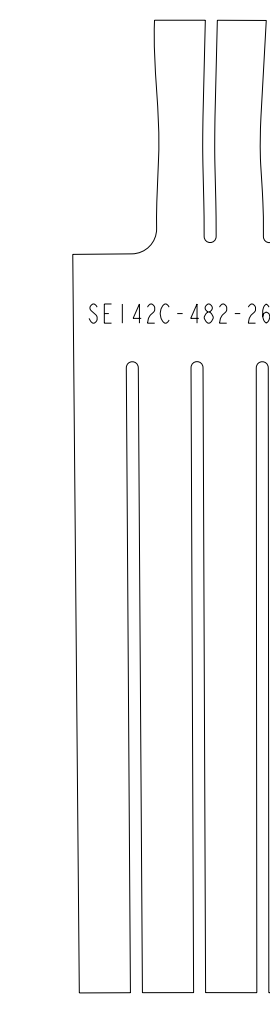

INSTANCE:
SEI42C-482_FLAT_260

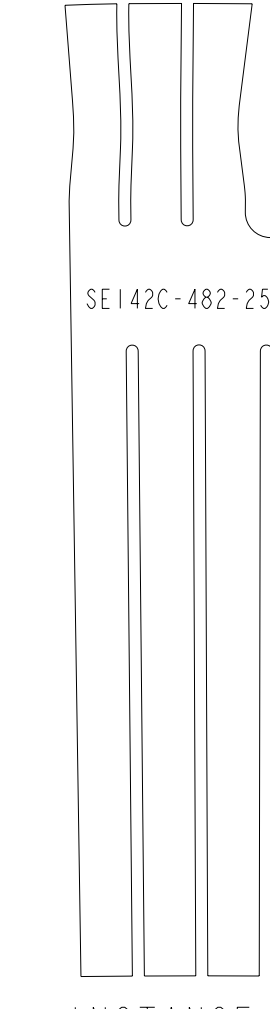

INSTANCE:
SEI42C-482_FLAT_259

91

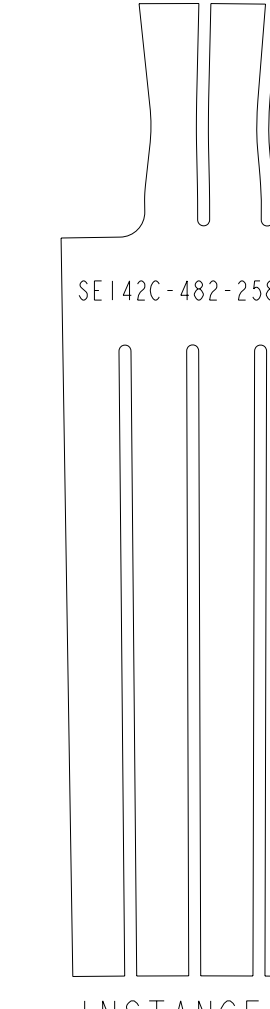

INSTANCE:
SEI42C-482_FLAT_258

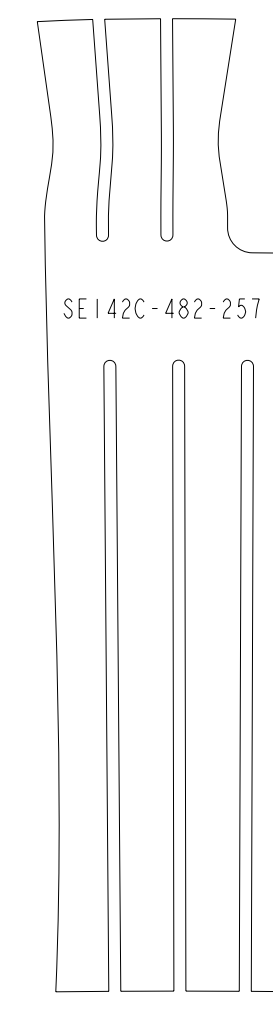

90

INSTANCE:
SEI42C-482_FLAT_257

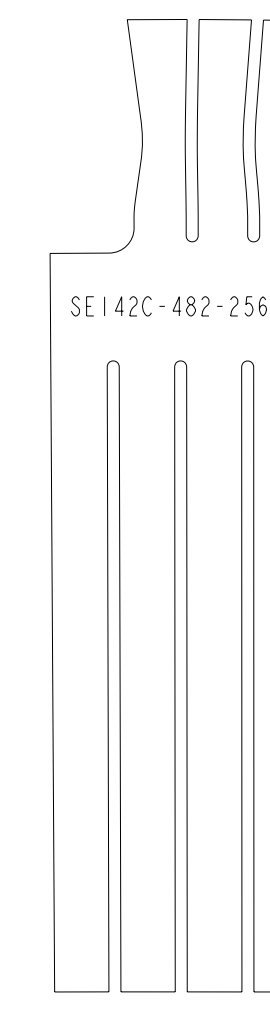

INSTANCE:
SEI42C-482_FLAT_256

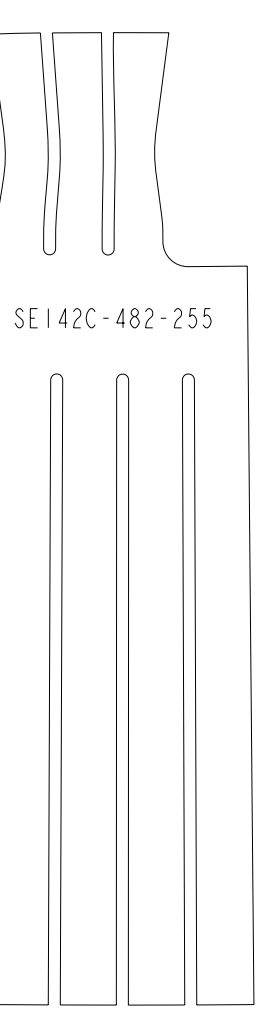

INSTANCE:
SEI42C-482_FLAT_255

89

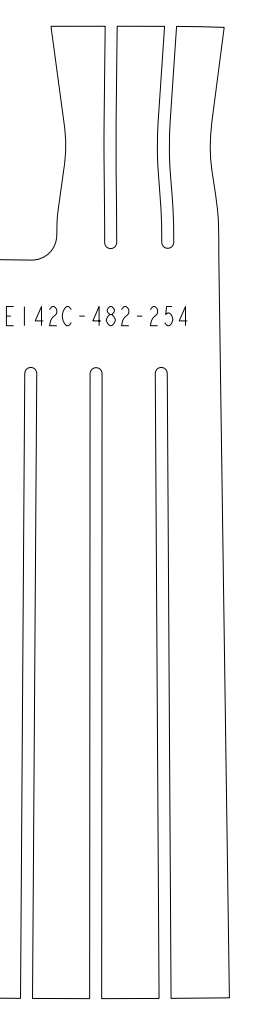

INSTANCE:
SEI42C-482_FLAT_254

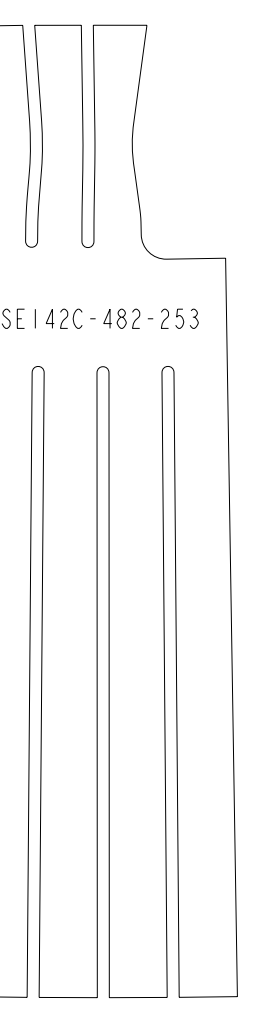

INSTANCE:
SEI42C-482_FLAT_253

88

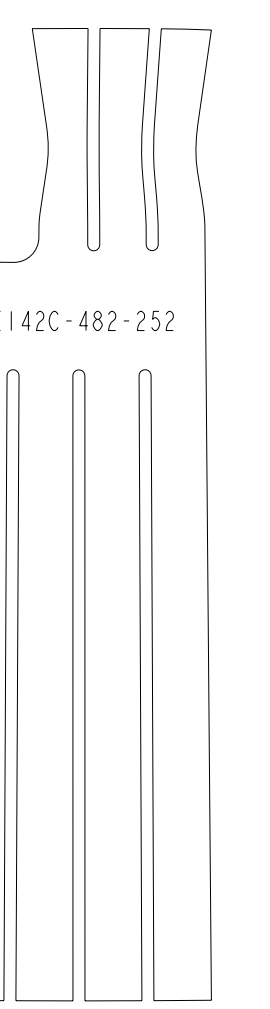

INSTANCE:
SEI42C-482_FLAT_252

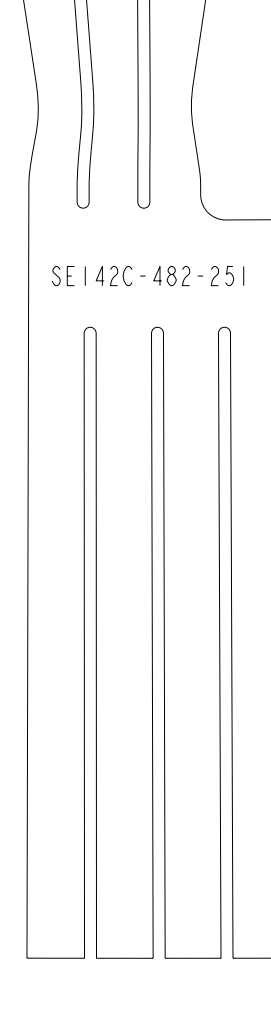

INSTANCE:
SEI42C-482_FLAT_251

87

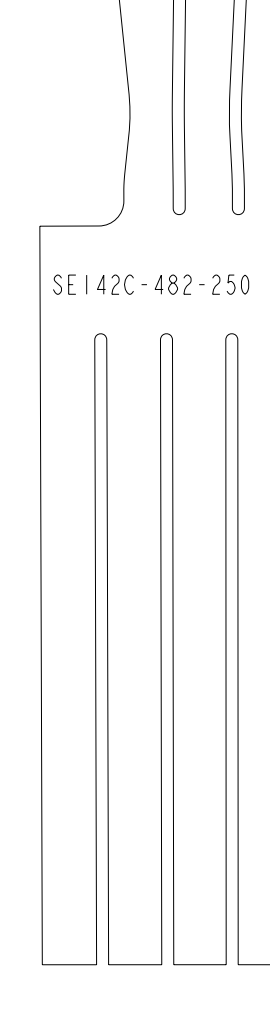

INSTANCE:
SEI42C-482_FLAT_250

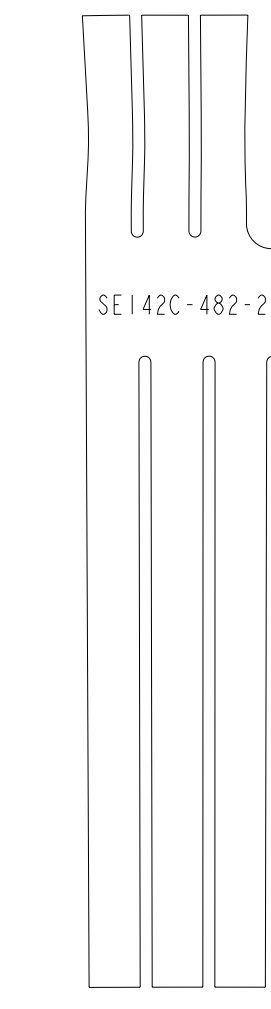

INSTANCE:
SEI42C-482_FLAT_249

86

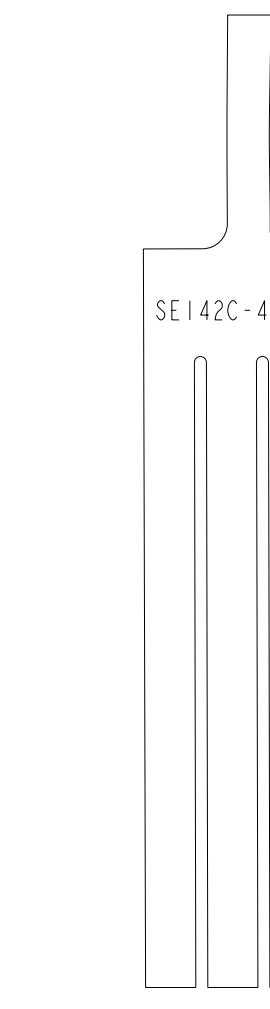

INSTANCE:
SEI42C-482_FLAT_248

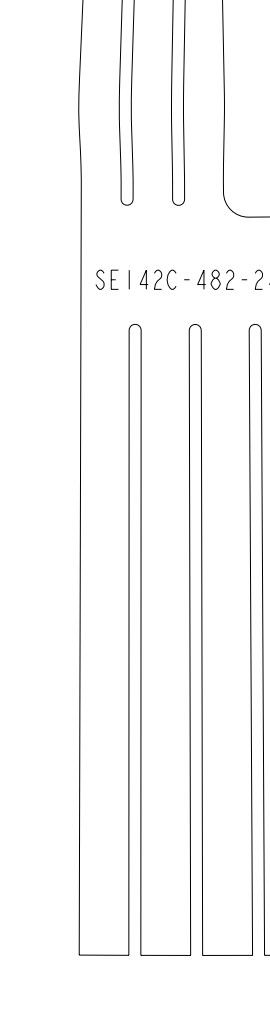

INSTANCE:
SEI42C-482_FLAT_247

85

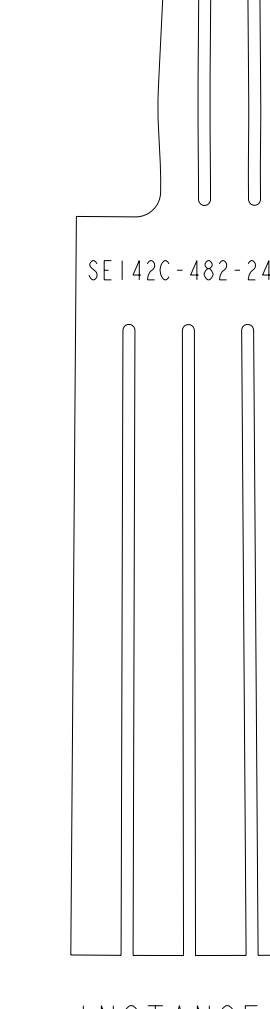

INSTANCE:
SEI42C-482_FLAT_246

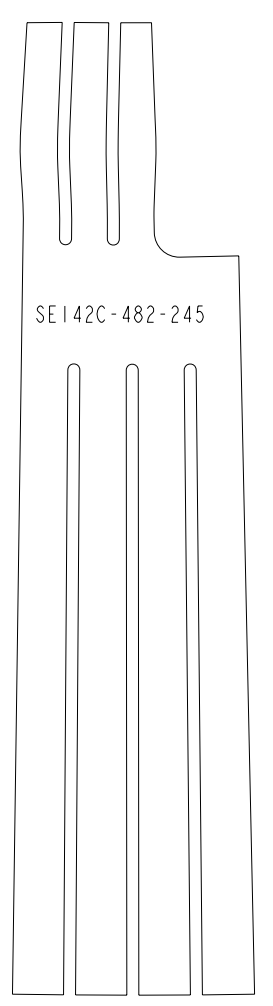

84

INSTANCE:
SEI42C-482_FLAT_245

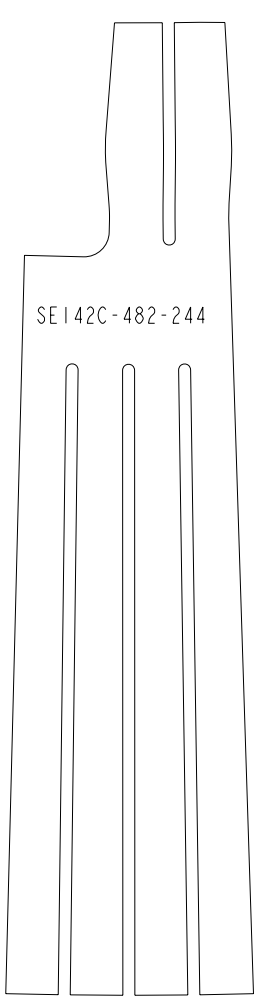

INSTANCE:
SEI42C-482_FLAT_244-NEW

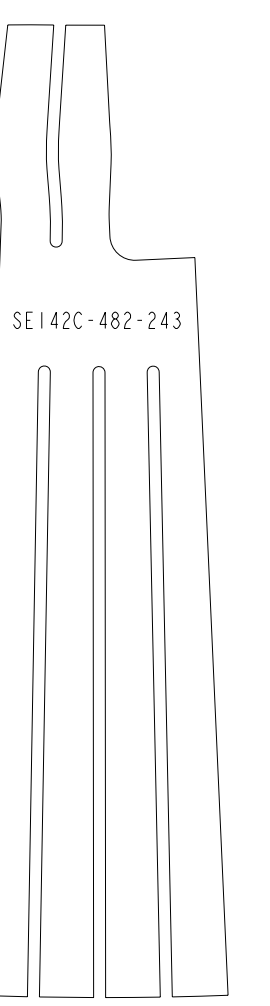

INSTANCE:
SEI42C-482_FLAT_243-NEW

83

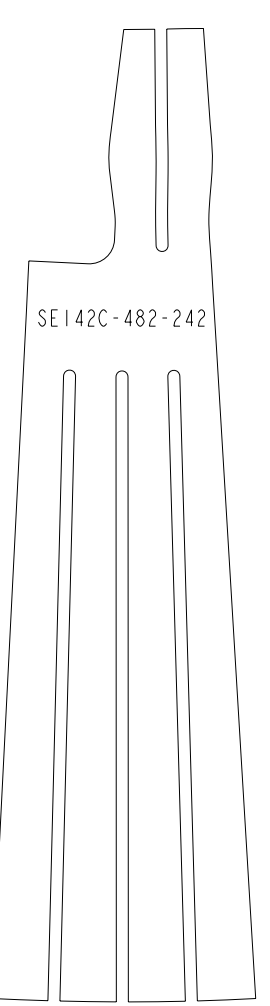

INSTANCE:
SEI42C-482_FLAT_242-NEW

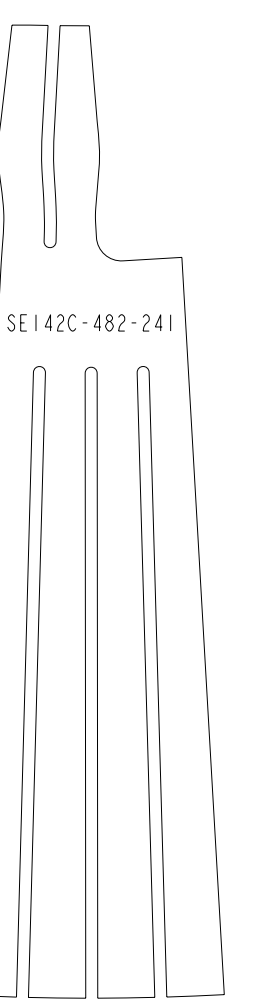

INSTANCE:
SEI42C-482_FLAT_241-NEW

82

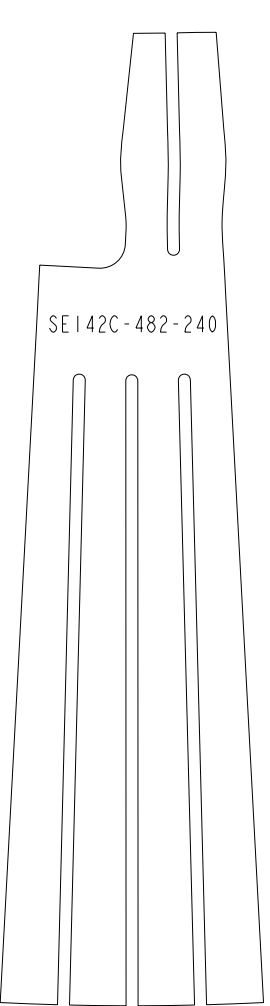

INSTANCE:
SEI42C-482_FLAT_240-NEW

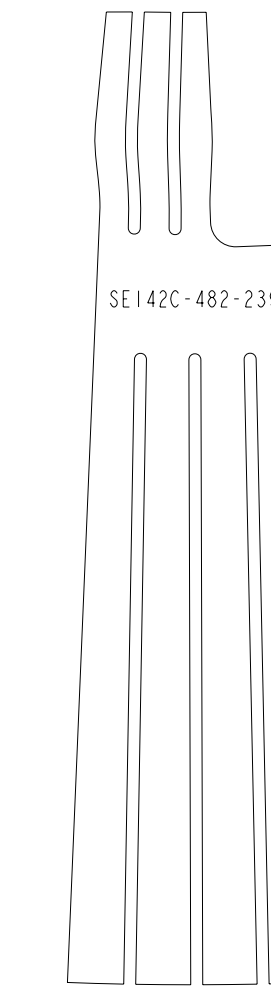

INSTANCE:
SEI42C-482_FLAT_239

81

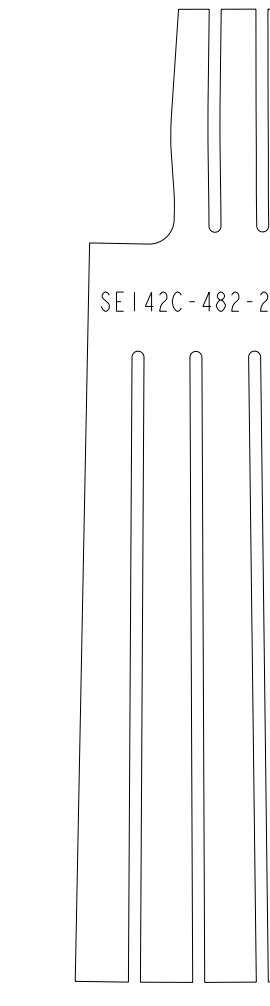

INSTANCE:
SEI42C-482_FLAT_238

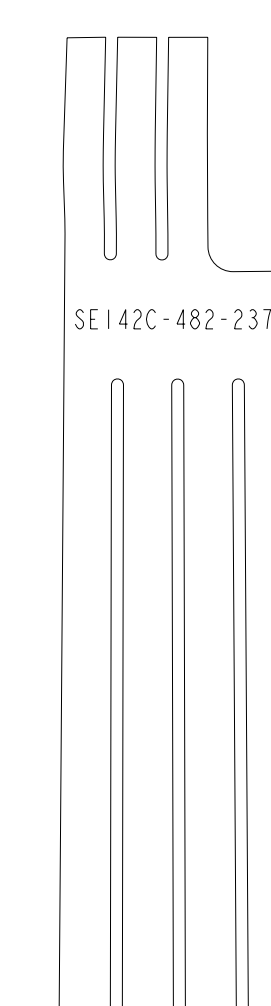

INSTANCE:
SEI42C-482_FLAT_237

80

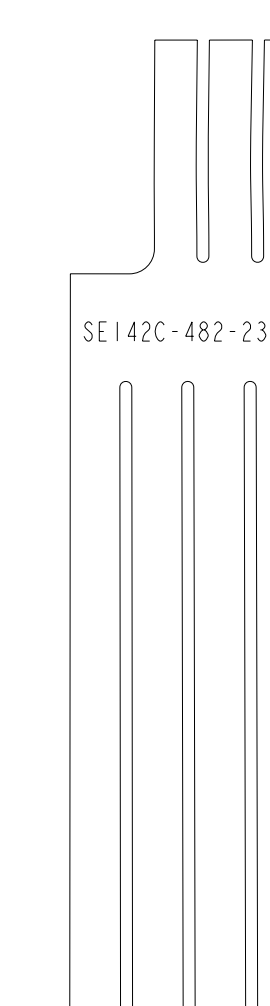

INSTANCE:
SEI42C-482_FLAT_236

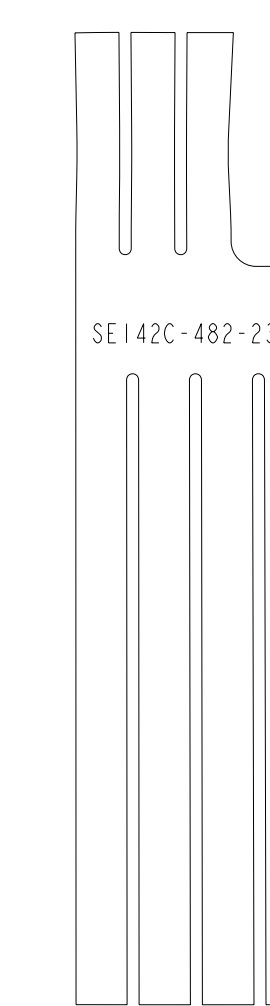

INSTANCE:
SEI42C-482_FLAT_235

79

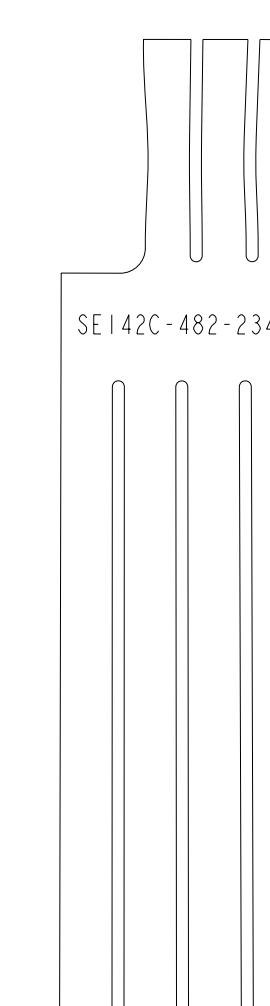

INSTANCE:
SEI42C-482_FLAT_234

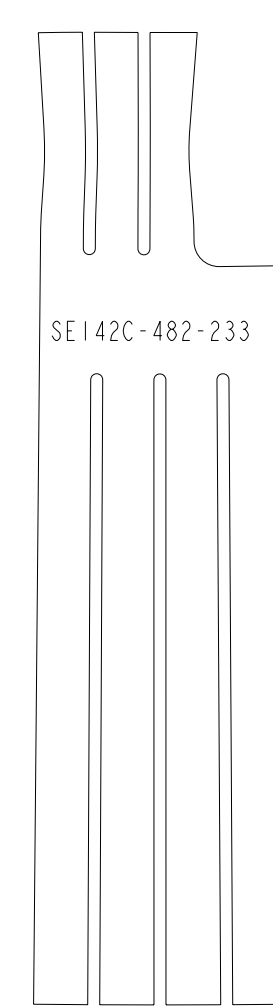

78

INSTANCE:
SEI42C-482_FLAT_233

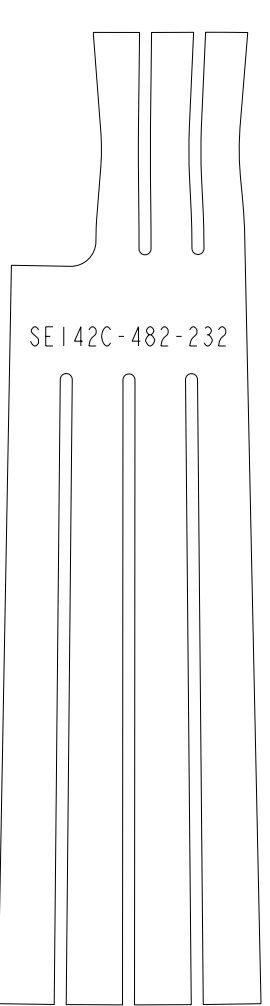

INSTANCE:
SEI42C-482_FLAT_232

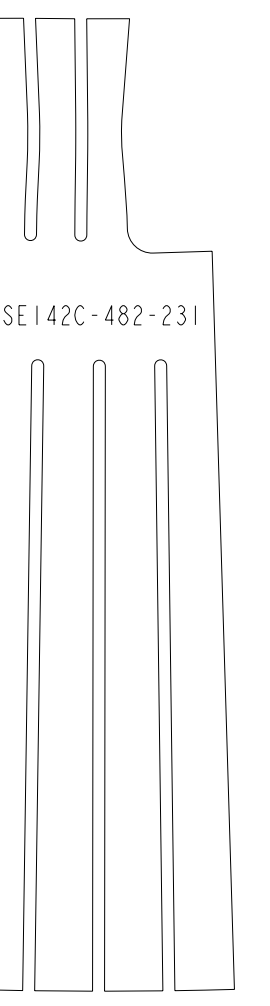

INSTANCE:
SEI42C-482_FLAT_231

77

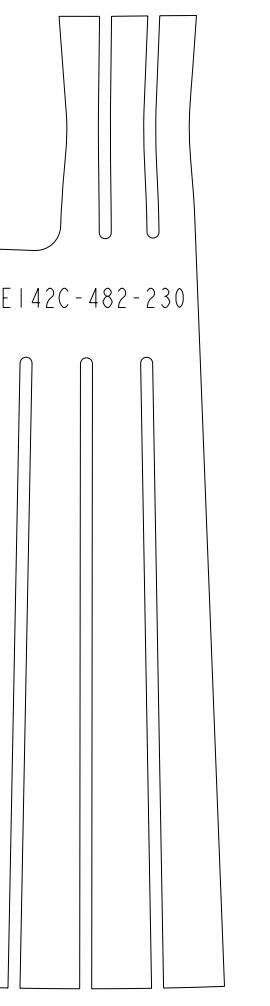

INSTANCE:
SEI42C-482_FLAT_230

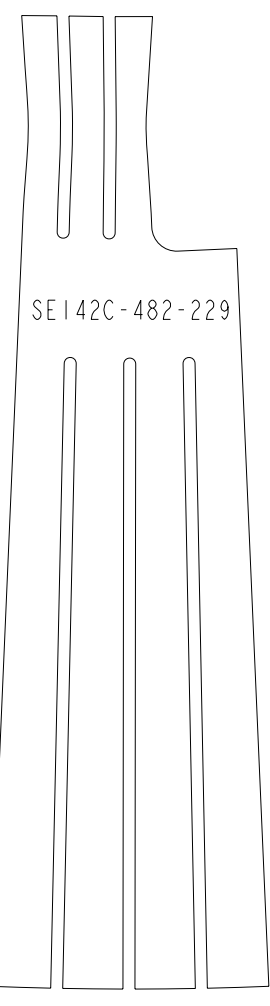

INSTANCE:
SEI42C-482_FLAT_229

76

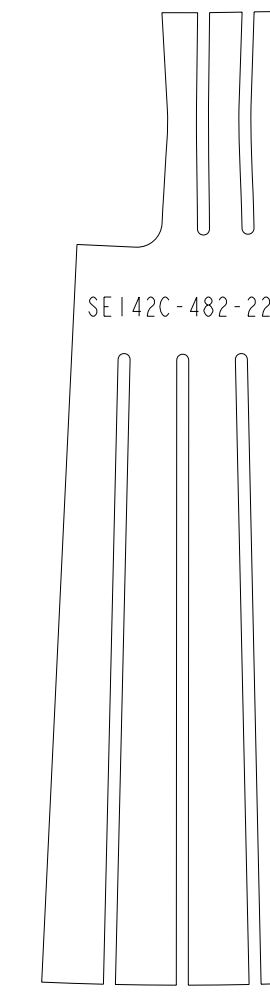

INSTANCE:
SEI42C-482_FLAT_228

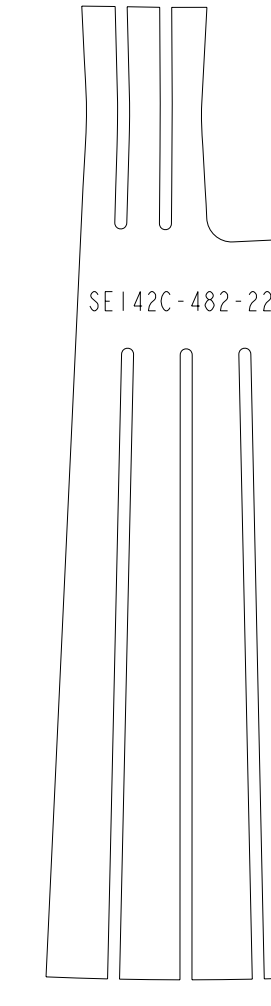

INSTANCE:
SEI42C-482_FLAT_227

75

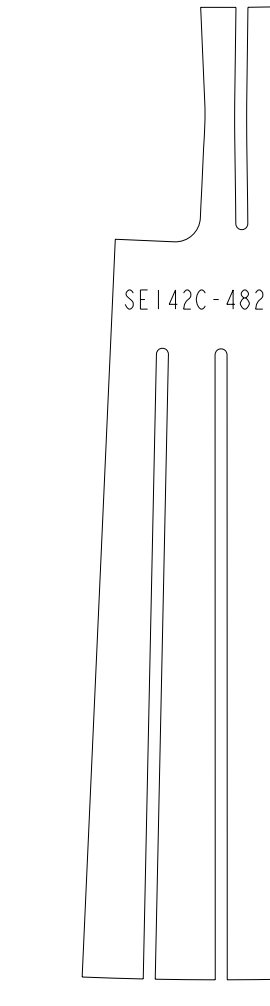

INSTANCE:
SEI42C-482_FLAT_226

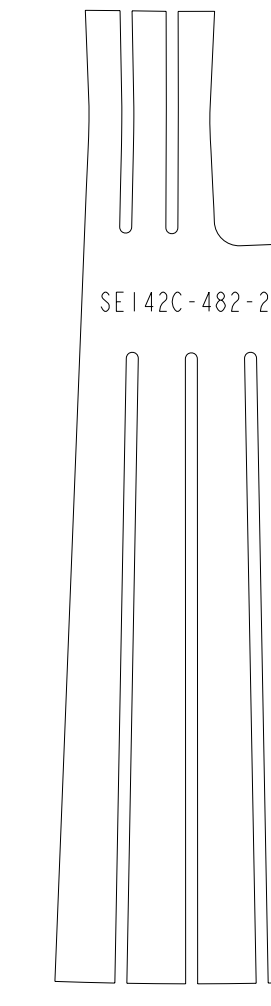

INSTANCE:
SEI42C-482_FLAT_225

74

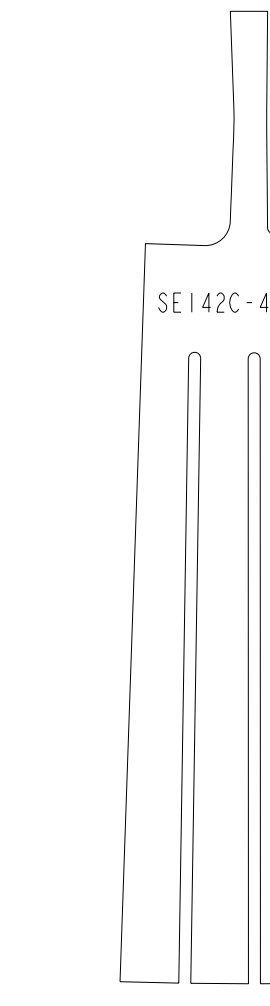

INSTANCE:
SEI42C-482_FLAT_224

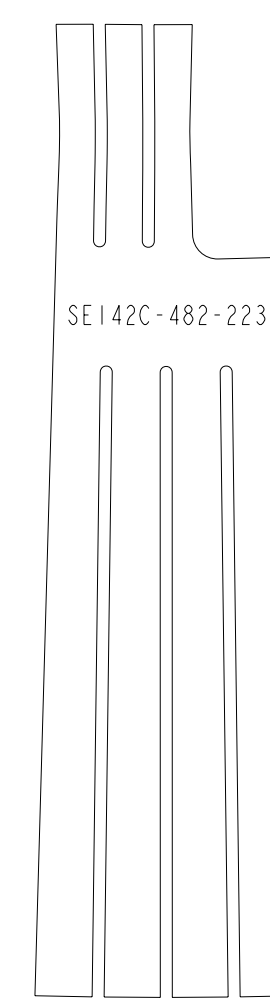

INSTANCE:
SEI42C-482_FLAT_223

73

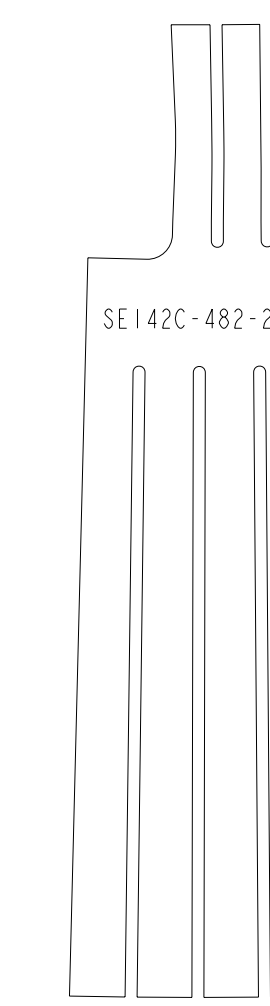

INSTANCE:
SEI42C-482_FLAT_222

SCALE ALL VIEWS: 1:00

Oak Ridge National Laboratory managed for the DEPARTMENT OF ENERGY under U.S. GOVERNMENT CONTRACT DE-AC05-00OR22725 UT-BATTELLE, LLC., Oak Ridge, Tennessee PROJECT NAME:									
UT-BATTELLE NATIONAL COMPACT STELLARATOR EXPERIMENT MODULAR COIL TYPE - C SIDE -B UPPER CLADDING FLAT PATTERN LAYOUT									
VERSION NO.	PLANT	BLDG	FL	SHT	OF	TYPE	CLASS		
3	X-10	5700	3	5	5	S	U		
RELEASE LEVEL		SEI42C-482						REV	
WIP								I	